



OUTLANDER PHEV - ENGLISH - OGGE19E1

OUTLANDER PHEV - ENGLISH - OGGE19E1

OUTLANDER PHEV

OWNER'S MANUAL

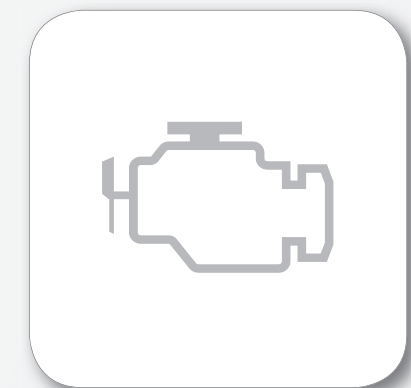
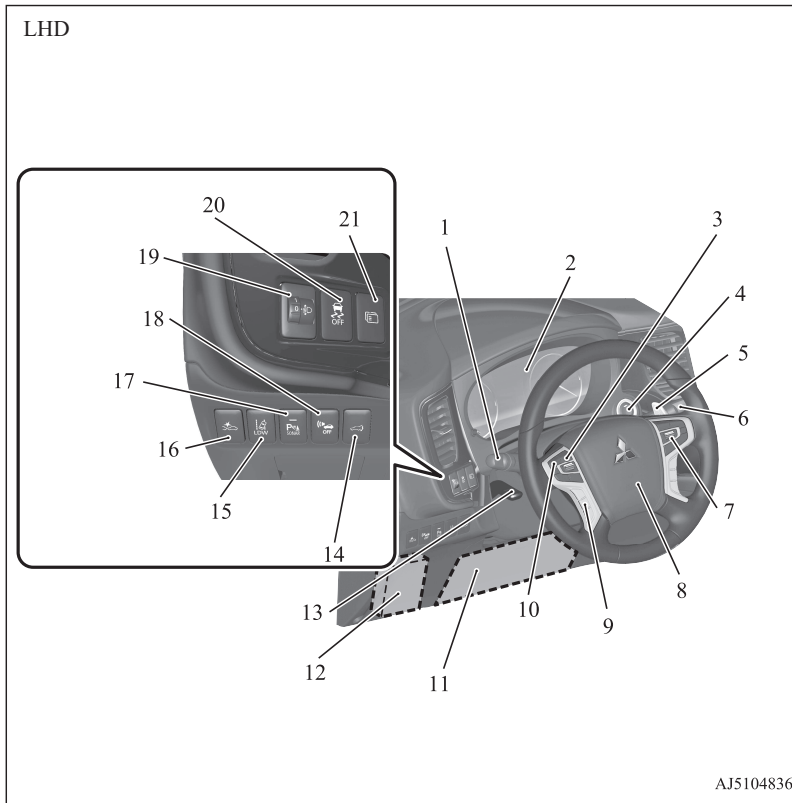
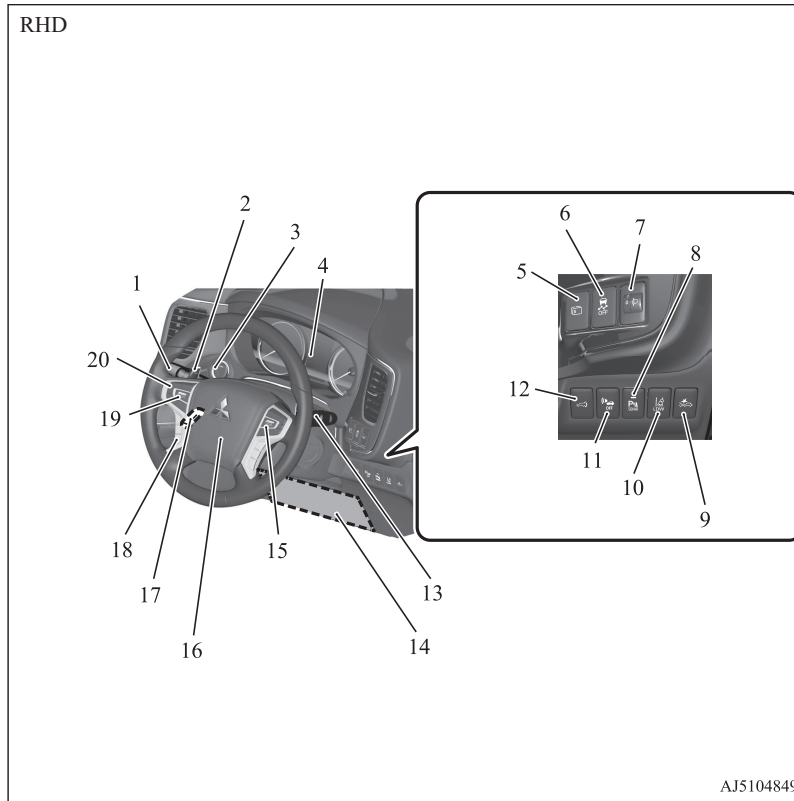

Table of contents

Overview	1
General information	2
Charging	3
Locking and unlocking	4
Seats and seat belts	5
Instruments and controls	6
Starting and driving	7
For pleasant driving	8
For emergencies	9
Vehicle care	10
Maintenance	11
Specifications	12
Alphabetical index	13
Declaration of Conformity	14



1. Combination headlamps and dipper switch p. 6-59
Automatic High-Beam (AHB) switch* p. 6-62
Turn-signal lever p. 6-67
Front fog lamp switch p. 6-68
Rear fog lamp switch p. 6-69
2. Instruments p. 6-02
3. Steering wheel audio remote control switches p. 8-28
[For DISPLAY AUDIO, Smartphone Link Display Audio and MITSUBISHI Multi-Communication System (MMCS), refer to the separate owner's manual.]
4. Power switch p. 7-11
5. Regenerative braking level selector (paddle type)* p. 7-19
6. Windscreen wiper and washer switch p. 6-69
Rear window wiper and washer switch p. 6-72
Headlamp washer switch p. 6-73
7. Cruise control switches* p. 7-45, 7-55
8. Supplemental restraint system (SRS) - airbag (for driver's seat) p. 5-25, 5-29
Horn switch p. 6-77
9. Bluetooth® 2.0 interface* p. 8-51
10. Camera switch* p. 7-112
11. Supplemental restraint system (SRS) - front knee airbag (for driver's seat) p. 5-25, 5-29
12. Fuses p. 11-16
13. Steering wheel height and reach adjustment lever p. 7-07
14. Driver's side electric tailgate switch* p. 4-20
15. Lane Departure Warning (LDW) switch* p. 7-88
16. Forward Collision Mitigation System (FCM) and Ultrasonic mis-acceleration Mitigation System (UMS) ON/OFF switch* p. 7-72
17. Sonar switch* p. 7-99, 7-103
18. Acoustic Vehicle Alerting System (AVAS) OFF switch p. 7-32
19. Headlamp levelling switch* p. 6-66
20. Active stability control (ASC) OFF switch p. 7-44
21. Multi information display switch p. 6-06



1. Combination headlamps and dipper switch p. 6-59
Automatic High-Beam (AHB) switch* p. 6-62
Turn-signal lever p. 6-67
Front fog lamp switch p. 6-68
Rear fog lamp switch p. 6-69
2. Regenerative braking level selector (paddle type)* p. 7-19
3. Power switch p. 7-11
4. Instruments p. 6-02
5. Multi information display switch p. 6-06
6. Active stability control (ASC) OFF switch p. 7-44
7. Headlamp levelling switch* p. 6-66
8. Sonar switch* p. 7-99, 7-103
9. Forward Collision Mitigation System (FCM) and Ultrasonic mis-
acceleration Mitigation System (UMS) ON/OFF switch* p. 7-72
10. Lane Departure Warning (LDW) switch* p. 7-88
11. Acoustic Vehicle Alerting System (AVAS) OFF switch p. 7-32
12. Driver's side electric tailgate switch* p. 4-20
13. Windscreen wiper and washer switch p. 6-69
Rear window wiper and washer switch p. 6-72
Headlamp washer switch p. 6-73
14. Supplemental restraint system (SRS) - front knee airbag (for driv-
er's seat) p. 5-25, 5-29
15. Cruise control switches* p. 7-45, 7-55
16. Supplemental restraint system (SRS) - airbag (for driver's seat)
p. 5-25, 5-29
Horn switch p. 6-77
17. Steering wheel height and reach adjustment lever p. 7-07
18. Bluetooth® 2.0 interface* p. 8-51
19. Steering wheel audio remote control switches p. 8-28
[For DISPLAY AUDIO, Smartphone Link Display Audio and
MITSUBISHI Multi-Communication System (MMCS), refer to
the separate owner's manual.]
20. Camera switch* p. 7-112

1

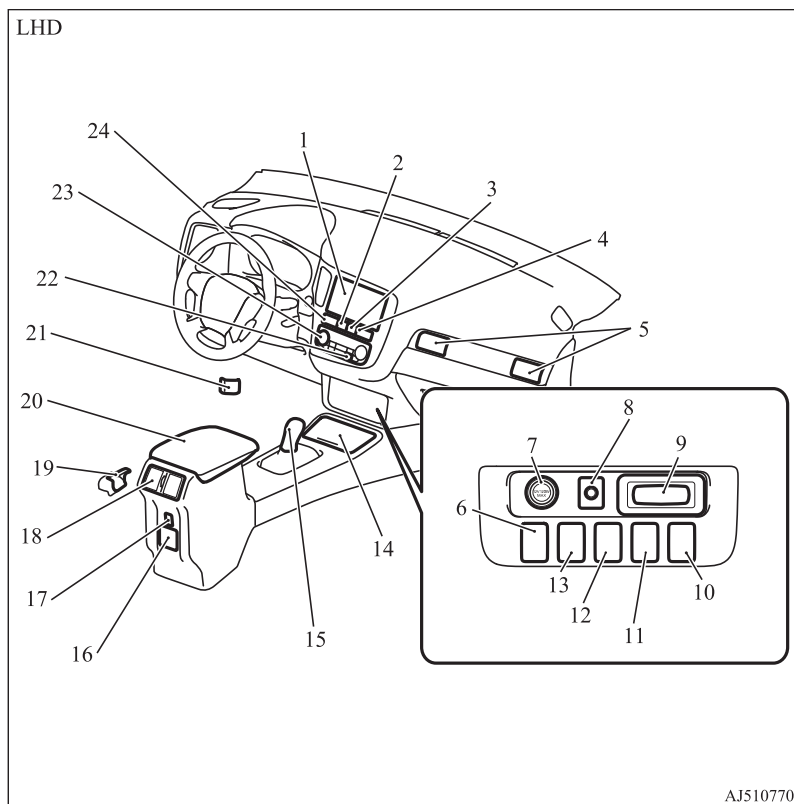

1. Multi Around Monitor* p. 7-109
Audio* p. 8-15
[For DISPLAY AUDIO, Smartphone Link Display Audio and MITSUBISHI Multi-Communication System (MMCS), refer to the separate owner's manual.]
2. Hazard warning flasher switch p. 6-67
3. ECO mode switch p. 6-68
4. Front passenger's airbag indicator p. 5-28
5. Passenger's ventilators p. 8-02
6. USB input terminal* p. 8-71
7. Accessory socket* p. 8-75
Cigarette lighter* p. 8-75
8. Electric tailgate power switch* p. 4-20
9. Key slot p. 7-15
10. 220-240 V AC power supply switch* p. 8-76
11. Blind Spot Warning (BSW) switch* p. 7-82
12. Heated steering wheel switch* p. 6-76
13. Heated windscreen switch* p. 6-75
14. Cup holder p. 8-84
15. Selector lever (Joystick type) p. 7-15
16. 220-240 V AC power supply* p. 8-76
17. USB input terminal* p. 8-71
18. Rear ventilators p. 8-02
19. Fuel tank filler door release lever p. 2-15
20. Floor console box p. 8-82
Arm rest
21. Bonnet release lever p. 11-04
22. Rear window demister switch p. 6-74
Wiper de-icer switch* p. 6-74
23. Automatic climate control air conditioner p. 8-06
24. Seat belt reminder p. 5-11

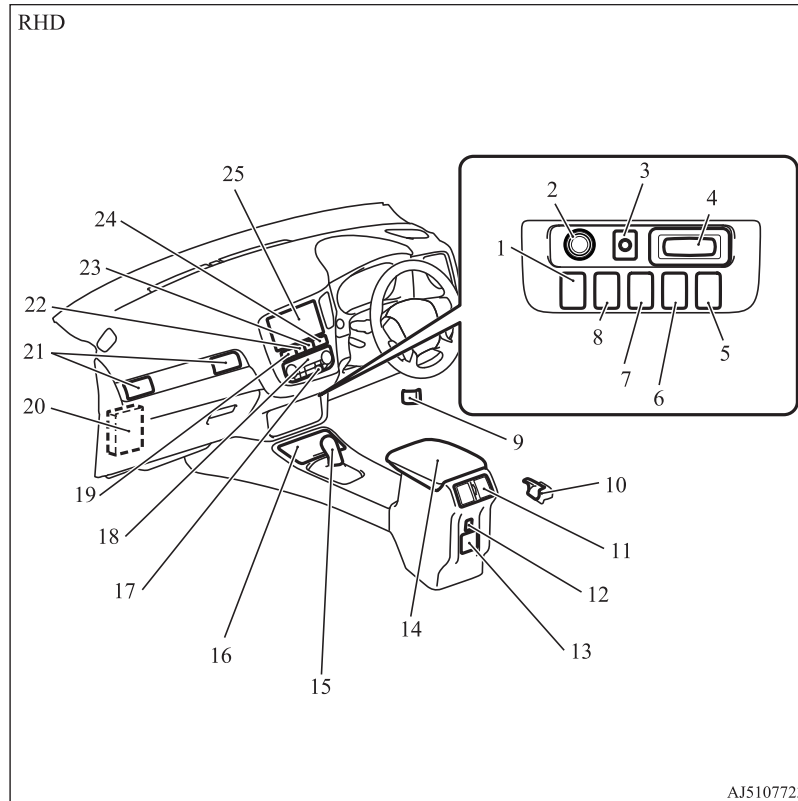

1. USB input terminal* p. 8-71
2. Accessory socket* p. 8-75
3. Electric tailgate power switch* p. 4-20
4. Key slot p. 7-15
5. 220-240 V AC power supply switch* p. 8-76
6. Blind Spot Warning (BSW) switch* p. 7-82
7. Heated steering wheel switch* p. 6-76
8. Heated windscreen switch* p. 6-75
9. Bonnet release lever p. 11-04
10. Fuel tank filler door release lever p. 2-15
11. Rear ventilators p. 8-02
12. USB input terminal* p. 8-71
13. 220-240 V AC power supply* p. 8-76
14. Floor console box p. 8-82
Arm rest
15. Selector lever (Joystick type) p. 7-15
16. Cup holder p. 8-84
17. Rear window demister switch p. 6-74
Wiper de-icer switch* p. 6-74
18. Automatic climate control air conditioner p. 8-06
19. Seat belt reminder p. 5-11
20. Fuses p. 11-16
21. Passenger's ventilators p. 8-02
22. Hazard warning flasher switch p. 6-67
23. ECO mode switch p. 6-68
24. Front passenger's airbag indicator p. 5-28
25. Multi Around Monitor* p. 7-109
Audio* p. 8-15
[For DISPLAY AUDIO, Smartphone Link Display Audio and MITSUBISHI Multi Communication System (MMCS), refer to the separate owner's manual.]

1

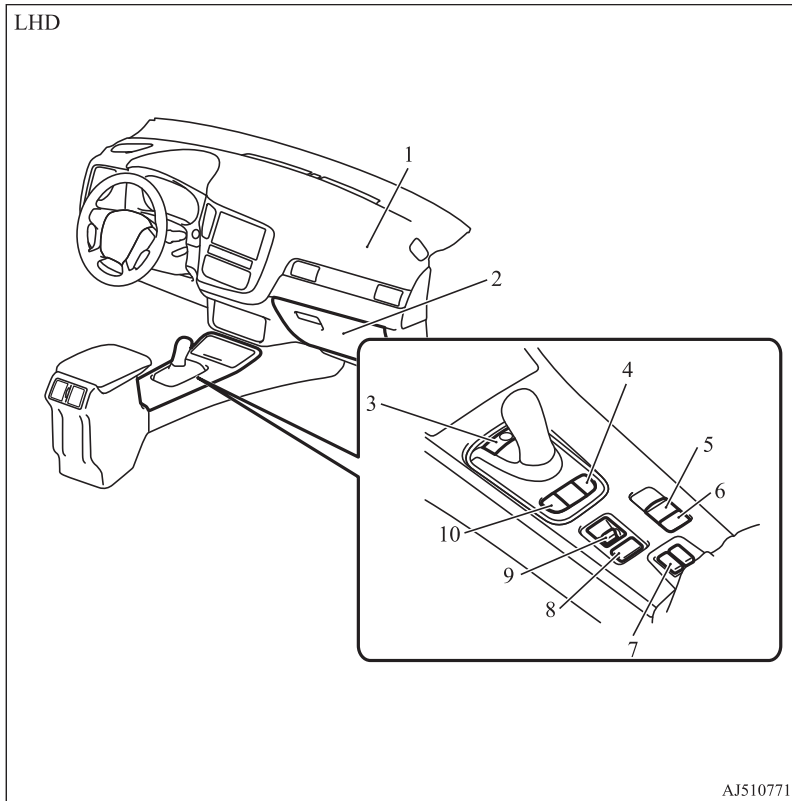

1. Supplemental restraint system (SRS) - airbag (for front passenger's seat) p. 5-25, 5-29
2. Glove box p. 8-82
Card holder p. 8-82
3. Electrical parking switch p. 7-18
4. EV switch p. 7-25
5. Electric parking brake switch p. 7-03
6. Brake auto hold switch p. 7-35
7. Heated seat switch* p. 5-04
8. SPORT mode switch p. 7-31
9. Drive mode switch p. 7-21
10. SAVE/CHARGE mode switch p. 7-28

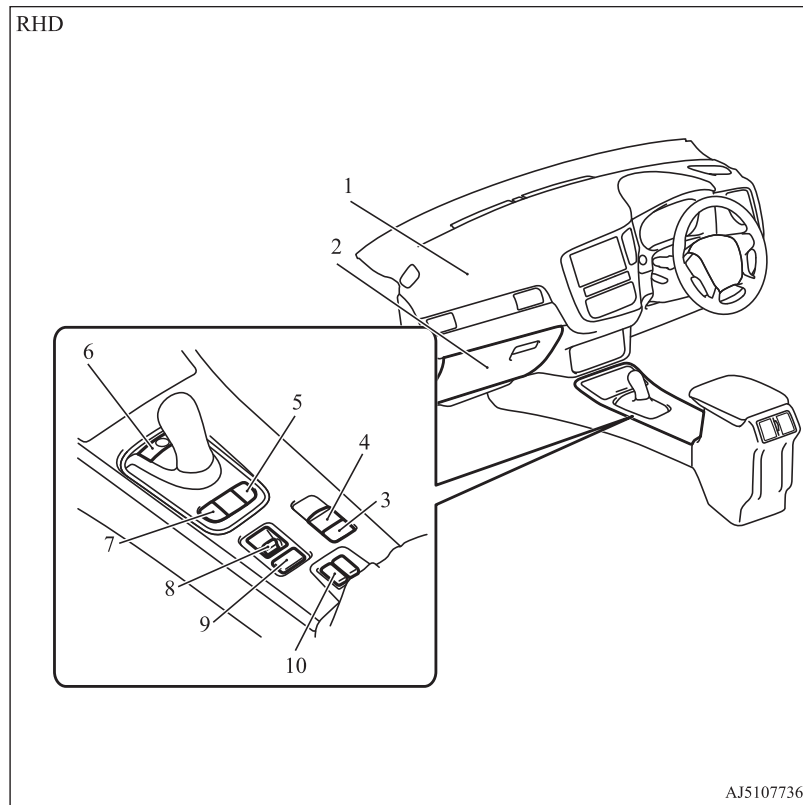

1. Supplemental restraint system (SRS) - airbag (for front passenger's seat) p. 5-25, 5-29
2. Glove box p. 8-82
Card holder p. 8-82
3. Brake auto hold switch p. 7-35
4. Electric parking brake switch p. 7-03
5. EV switch p. 7-25
6. Electrical Parking switch p. 7-18
7. SAVE/CHARGE mode switch p. 7-28
8. Drive mode switch p. 7-21
9. SPORT mode switch p. 7-31
10. Heated seat switch* p. 5-04

1 Interior

E08500202112

LHD

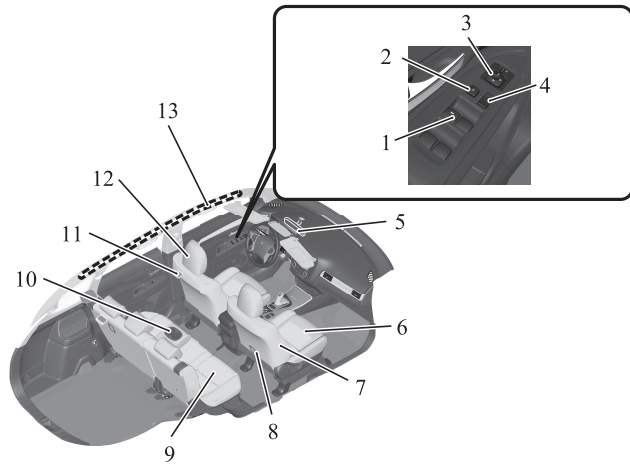

AJ5104881

- 1. Electric window control switch p. 4-34
- 2. Lock switch p. 4-35
- 3. Electric remote-controlled outside rear-view mirrors switch p. 7-09
- 4. Central door lock switch p. 4-16
- 5. Inside rear-view mirror p. 7-07
- 6. Front seats p. 5-03
- 7. Supplemental restraint system (SRS) -side airbag (for front seat) p. 5-25, 5-32
- 8. Tether anchorages for child restraint system (for front passenger's seat) p. 5-22
- 9. Rear seats p. 5-05
- 10. Armrest p. 5-05
Cup holder p. 8-84
- 11. Room lamp (rear) p. 8-80, 11-26
- 12. Head restraints p. 5-05
- 13. Supplemental restraint system (SRS) - curtain airbag p. 5-25, 5-32

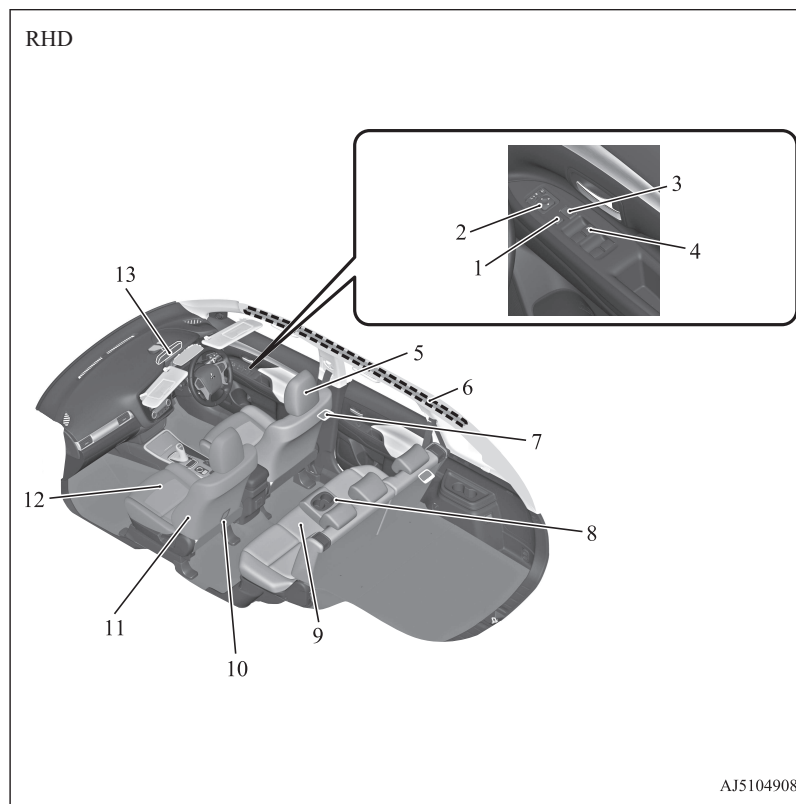

1. Lock switch p. 4-35
2. Electric remote-controlled outside rear-view mirrors switch p. 7-09
3. Central door lock switch p. 4-16
4. Electric window control switch p. 4-34
5. Head restraints p. 5-05
6. Supplemental restraint system (SRS) - curtain airbag p. 5-25, 5-32
7. Room lamp (rear) p. 8-80, 11-26
8. Armrest p. 5-05
Cup holder p. 8-84
9. Rear seats p. 5-05
10. Tether anchorages for child restraint system (for front passenger's seat) p. 5-22
11. Supplemental restraint system (SRS) - side airbag (for front seat)* p. 5-25, 5-32
12. Front seats p. 5-03
13. Inside rear-view mirror p. 7-07

Interior

1

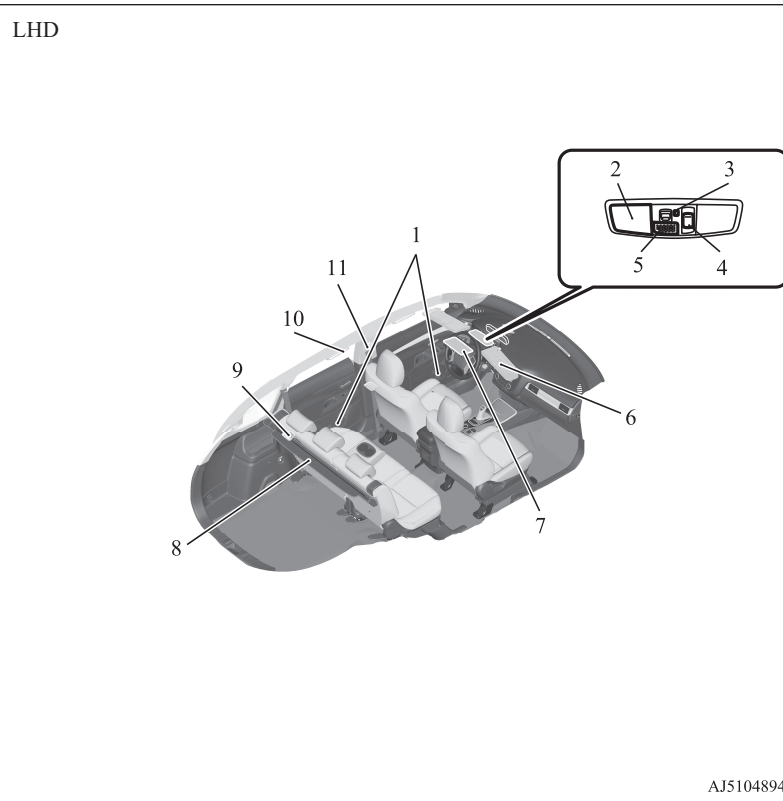

1. Bottle holder p. 8-84
2. Map & room lamps (front) p. 8-80, 8-80, 11-26
3. Downlight p. 8-81
4. Sunroof switch* p. 4-36
5. Hands-free microphone* p. 8-52
6. Sun visors p. 8-73
Vanity mirror p. 8-73
Card holder p. 8-73
7. Sunglasses holder* p. 8-83
8. Cargo area cover p. 8-85
9. Luggage room lamp p. 8-81, 11-26
10. Assist grips p. 8-86
Coat hook p. 8-86
11. Adjustable seat belt anchor p. 5-12
Seat belts p. 5-09

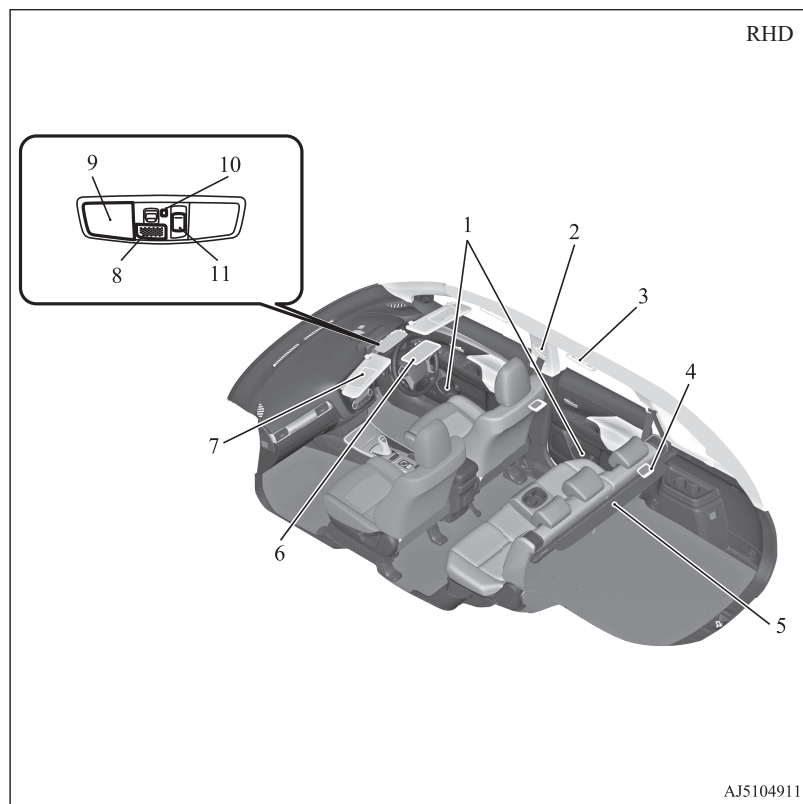

1. Bottle holder p. 8-84
2. Adjustable seat belt anchor p. 5-12
Seat belts p. 5-09
3. Assist grips p. 8-86
Coat hook p. 8-86
4. Luggage room lamp p. 8-81, 11-26
5. Cargo area cover p. 8-85
6. Sunglasses holder* p. 8-83
7. Sun visors p. 8-73
Vanity mirror p. 8-73
Card holder p. 8-73
8. Hands-free microphone* p. 8-52
9. Map & room lamps (front) p. 8-80, 8-80, 11-26
10. Downlight p. 8-81
11. Sunroof switch* p. 4-36

Luggage area

1 Luggage area

E08500301523

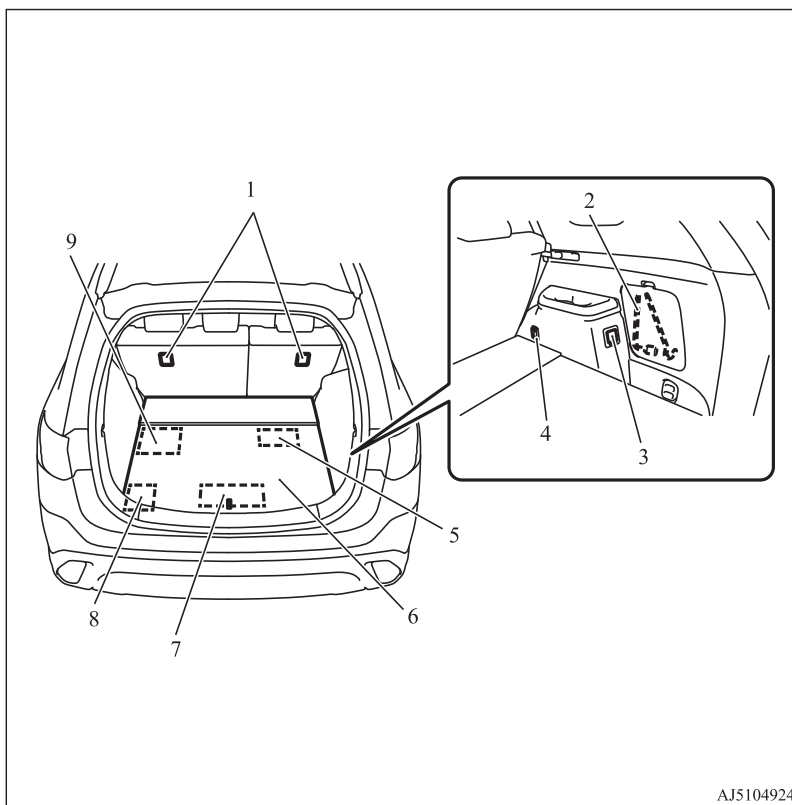

1. Tether anchorages for child restraint system p. 5-22
2. Tools p. 9-06
3. Accessory socket* p. 8-75
220-240 V AC power supply* p. 8-76
4. Luggage hooks p. 8-87
5. Jack p. 9-06
6. Luggage floor box p. 8-83
7. EV charging cable* p. 3-07
8. Auxiliary battery p. 11-09
9. Tyre repair kit p. 9-07

Outside (Front)

1

E08500402909

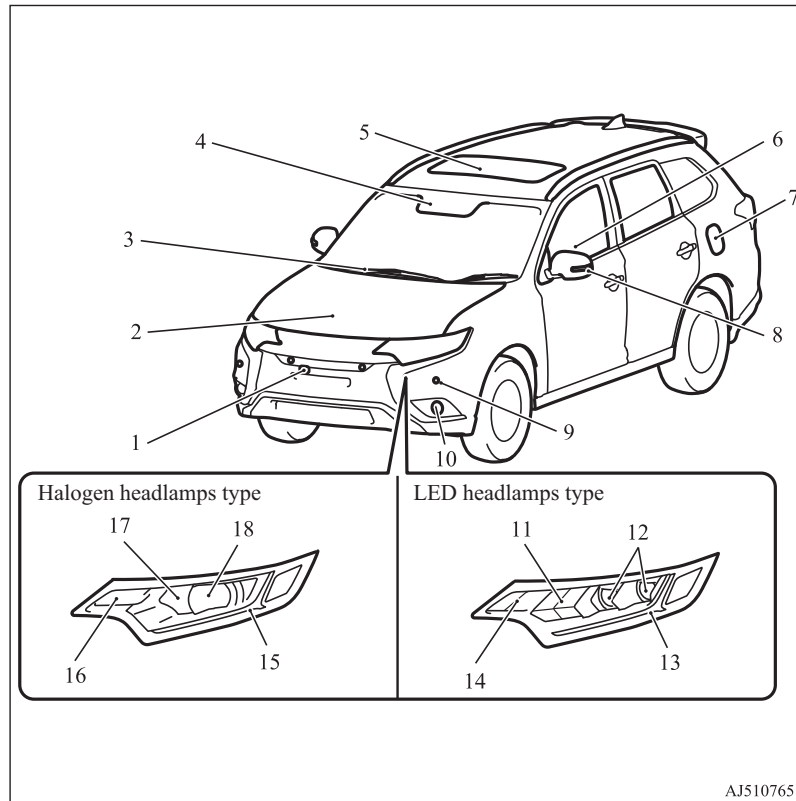

1. Front-view camera* p. 7-109
2. Bonnet p. 11-04
3. Windscreen wipers p. 6-69
4. Sensor* [for Automatic High-Beam (AHB)*, Forward Collision Mitigation System (FCM)* and Lane Departure Warning (LDW)*] p. 6-62, 7-67, 7-88
5. Sunroof* p. 4-36
6. Electric window control p. 4-34
7. Fuel tank filler p. 2-15
8. Side turn-signal lamps p. 6-67, 11-25
9. Ultrasonic misacceleration Mitigation System (UMS)* p. 7-77
10. Front fog lamps p. 6-68, 11-25, 11-28
11. Headlamps, high-beam p. 6-61, 11-25, 11-27
12. Headlamps, low beam p. 6-61, 11-25
13. Position lamps p. 6-61, 11-25
14. Front turn-signal lamps p. 6-67, 11-25, 11-28
15. Position lamps p. 6-59, 11-25
16. Front turn-signal lamps p. 6-67, 11-25, 11-28
17. Headlamps, high-beam p. 6-61, 11-25, 11-27
18. Headlamps, low beam p. 6-61, 11-25, 11-26

AJ5107651

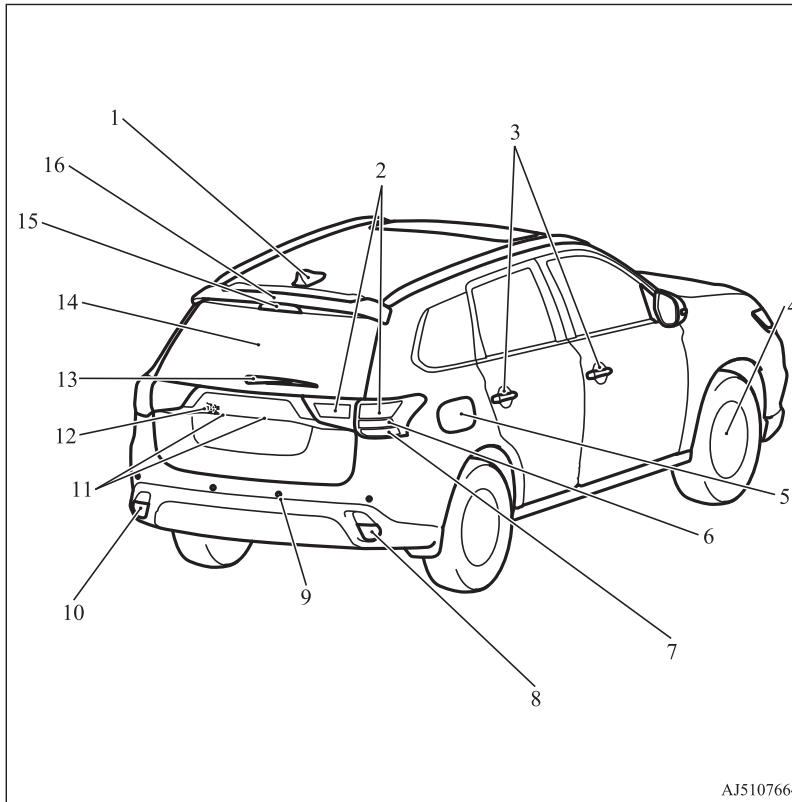

AJ5107664

1. Antenna
2. Tail lamps p. 11-25, 11-30
3. Keyless entry system p. 4-03
Keyless operation system p. 4-06
Locking and unlocking the doors p. 4-14
4. Changing tyres p. 9-13
Tyre pressure monitoring system (TPMS) p. 7-92
Tyre inflation pressures p. 11-10
Tyre rotation p. 11-12
Snow traction device (tyre chains) p. 11-13
Size of tyres and wheels p. 12-09
5. Charging lid p. 3-12
Charging port courtesy lamp p. 3-06
6. Stop lamps p. 11-25, 11-30
7. Rear turn-signal lamps p. 6-67, 11-25, 11-30
8. Reversing lamp (LHD vehicles) p. 11-25, 11-30
Rear fog lamp (RHD vehicles) p. 6-69, 11-25, 11-30
9. Ultrasonic misacceleration Mitigation System (UMS)* p. 7-77
Reversing sensor system* p. 7-97
Parking sensors* p. 7-101
10. Rear fog lamp (LHD vehicles) p. 6-69, 11-25, 11-30
Reversing lamp (RHD vehicles) p. 11-25, 11-30
11. Licence plate lamps p. 11-25, 11-31
12. Rear-view camera* p. 7-105, 7-109
13. Rear window wiper p. 6-72
14. Tailgate* p. 4-19
Electric tailgate* p. 4-20
15. High-mounted stop lamp p. 11-25
16. Roof spoiler

Quick guide

E08500500010

Locking and unlocking the doors and tailgate

E08500601832

Keyless entry system

Press the remote control switch, and all doors and the tailgate will be locked or unlocked as desired.

The remote control switch will operate within approximately 4 m from the vehicle.

Vehicles without MITSUBISHI Remote Control

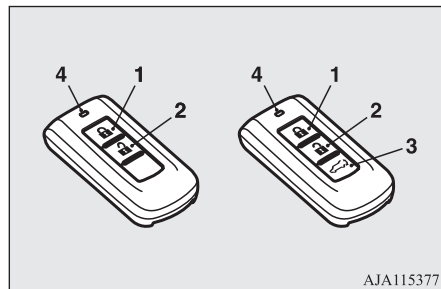

AJA115377

Vehicles with MITSUBISHI Remote Control

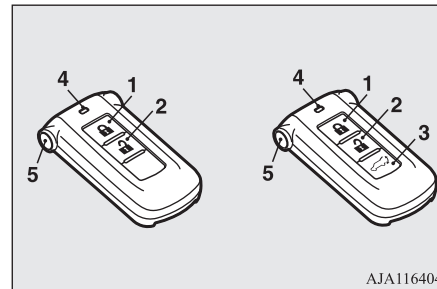

AJA116404

- 1- LOCK switch
- 2- UNLOCK switch
- 3- Electric tailgate switch
- 4- Indication lamp
- 5- Charging timer cancel switch*

Refer to “Keyless entry system” on page 4-03.

On vehicles with the electric tailgate, the tailgate can be opened automatically if you press the electric tailgate switch (3) after unlocking the tailgate.

Refer to “Electric tailgate” on page 4-20.

On vehicles with the MITSUBISHI Remote Control, the charging timer can be cancelled if you press the charging timer cancel switch (5) twice within 2 seconds.

Refer to “MITSUBISHI Remote Control” on page 3-20

1

Keyless operation system

When you are carrying the keyless operation key and within the operating range, if you press the driver’s or front passenger’s door lock/unlock switch (A), or the tailgate lock/unlock switch (B) (when locking) and the tailgate open switch (C) (when unlocking), the doors and the tailgate are locked/unlocked.

The operating range is approximately 70 cm from the driver’s door switch, front passenger’s door switch and the tailgate switches.

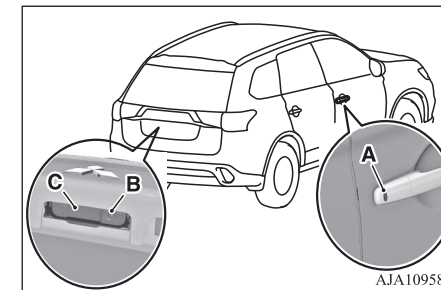

AJA109587

Refer to “Keyless operation system” on page 4-06.

1 Around the driver's seat

E08500801687

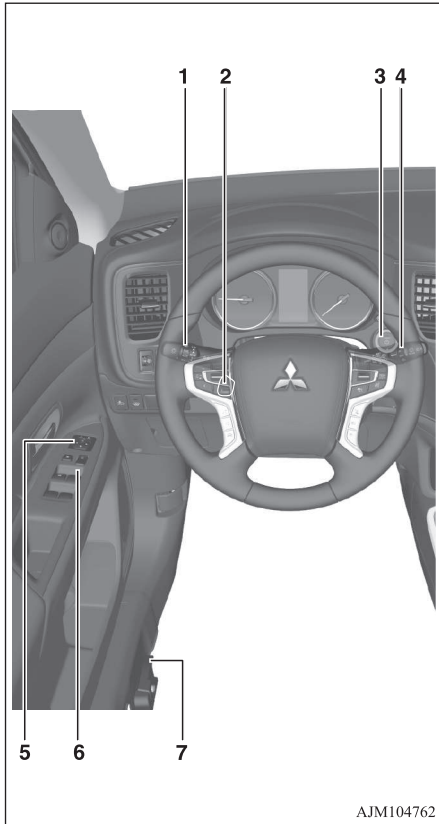

AJM104762

1-16 Overview

1-Combination headlamps

Rotate the switch to turn on the lamps.

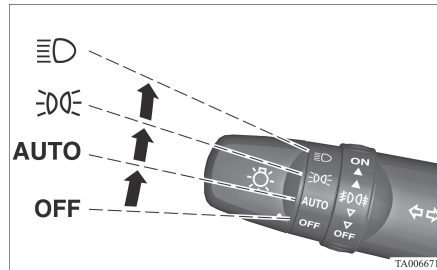

OFF	All lamps off {except for daytime running lamps}
AUTO	With the operation mode of the power switch in the "ON" position, head-lamps, position, tail, licence plate, instrument panel lamps and downlight turn on and off automatically in accordance with outside light level. {Daytime running lamps will go on while the tail lamps are off.} All lamps turn off automatically when the operation mode is put in OFF.
	Position, tail, licence plate, instrument panel lamps and downlight on

OGGE19E1



Headlamps and other lamps go on

Refer to "Combination headlamps and dipper switch" on page 6-59.

1-Turn-signal lever

The turn-signal lamps flash when the lever is operated

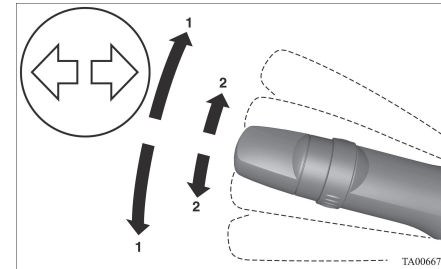

- 1- Turn-signals
- 2- Lane-change signals

Refer to "Turn-signal lever" on page 6-67.

2-Steering wheel height and reach adjustment

1. Release the lever while holding the steering wheel up.
2. Adjust the steering wheel to the desired position.

3. Securely lock the steering wheel by pulling the lever fully upward.

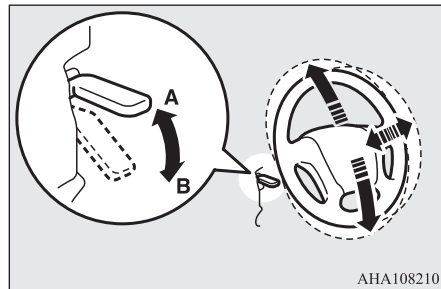

- A- Locked
- B- Release

Refer to “Steering wheel height and reach adjustment” on page 7-07.

3-Power switch

If you are carrying the keyless operation key, you can start the Plug-in Hybrid EV System.

If you press the power switch without depressing the brake pedal, you can change the operation mode in the order of OFF, ACC, ON, OFF.

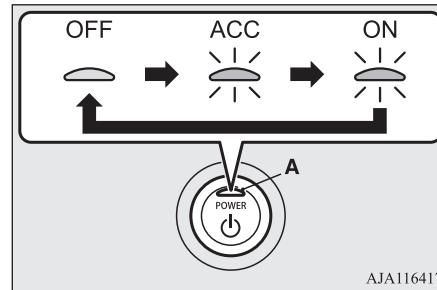

- OFF- The indication lamp (A) on the power switch turns off.
- ACC- The indication lamp on the engine switch illuminates orange.
- ON- The indication lamp on the power switch illuminates blue.

Refer to “Power switch” on page 7-11.

4-Wiper and washer switch

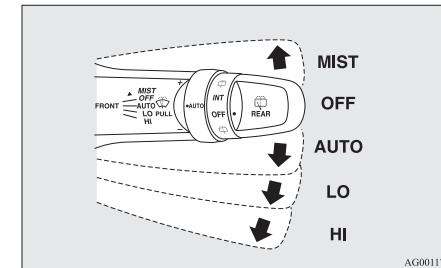

- MIST- Misting function
The wipers will operate once.
- OFF- Off
- AUTO- Auto-wiper control
The wipers will automatically operate depending on the degree of wetness on the windscreen.
- LO- Slow
- HI- Fast

The washer fluid will be sprayed onto the windscreen by pulling the lever towards you.
Refer to “Wiper and washer switch” on page 6-69.

1 5-Electric remote-controlled outside rear-view mirrors

To adjust the mirror position

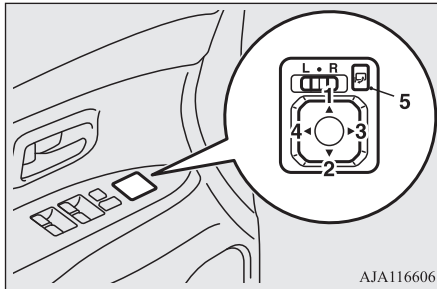

- L- Left outside mirror adjustment
- R- Right outside mirror adjustment
- 1- Up
- 2- Down
- 3- Right
- 4- Left
- 5- Mirror retractor switch

Refer to “Outside rear-view mirrors” on page 7-09.

6-Electric window control

Press the switch down for opening the window, and pull the switch for closing.

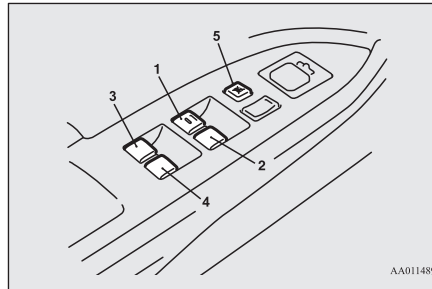

- 1- Driver's door window
- 2- Front passenger's door window
- 3- Rear left door window
- 4- Rear right door window
- 5- Lock switch

Lock switch

If you press the switch (5), the passenger's switches cannot be operated. To cancel, press it once again.

Refer to “Electric window control” on page 4-34.

7-Fuel tank filler door release lever

Open the fuel tank filler door.

The fuel tank filler is located on the rear left side of your vehicle.

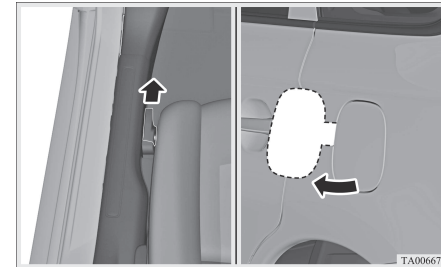

Refer to “Filling the fuel tank” on page 2-15.

Charging lid

E08502100023

Firmly apply the parking brake, press the electrical parking switch to shift into the “P” (PARK) position and put the operation mode of the power switch in the “OFF” position.

After unlocking the driver's door, push the rear portion of the charging lid (A) until it clicks, and open the charging lid.

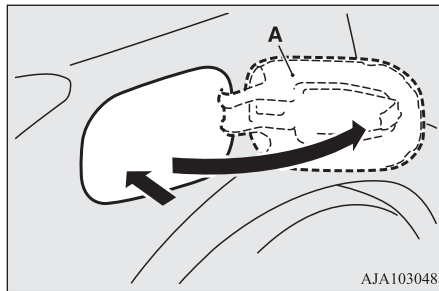

AJA103048

Release the tab (B) to open the inner lid.

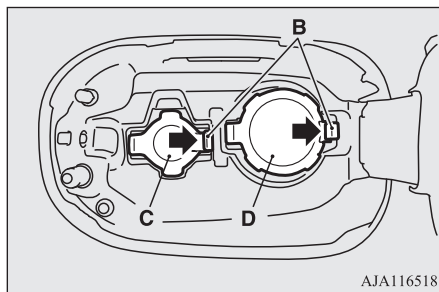

AJA116518

- C- Normal charging lid
- D- Quick charging lid

Refer to “Normal charging (charging method with rated AC 220-240V outlet)” on page 3-10 and “Quick charging (charging method with quick charger)” on page 3-17.

Electrical parking switch

E08502200037

Press the switch to lock the wheels when you are parking your vehicle. The indication lamp on the switch illuminates green.

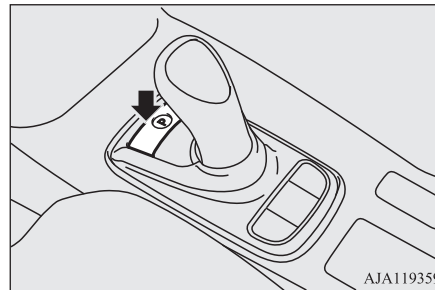

AJA119359

Refer to “Electrical parking switch” on page 7-18.

Selector lever (Joystick type)

E08502300025

Selector lever operation

The selector lever always returns to its home (•) position when it is released.

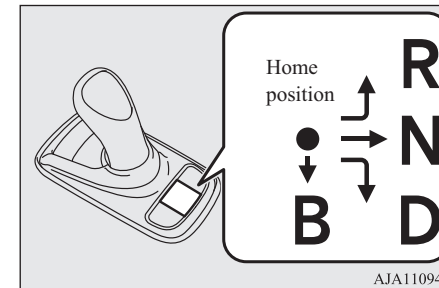

AJA110949

Move the selector lever slowly and securely in the following method.

- To select “D” (DRIVE) or “R” (REVERSE):
Move the selector lever in the direction of the arrow.
- To select “N” (NEUTRAL):
Move the selector lever in the direction of the arrow and hold it for a while.
- To select “B” (REGENERATIVE BRAKE):
Move the selector lever in the direction of the arrow.

Quick guide

1

You can shift the selector lever to “B” only when the select position is in the “D” (DRIVE) position.

Selector lever positions

“P” PARK

The wheels are locked. When you park your vehicle, be sure to apply the parking brake and press the electrical parking switch.

“R” REVERSE

This position is to back up.

“N” NEUTRAL

No power is transmitted to the wheels. The wheels are not locked.

“D” DRIVE

This position is for normal driving.

“B” REGENERATIVE BRAKE

This position is for the regenerative braking. You can adjust the regenerative braking force up to two levels.

Refer to “Selector lever (Joystick type)” on page 7-15

Multi information display

E08501201473

Always stop the vehicle in a safe place before operating.

The following information is included on the multi information display: odometer, tripmeter, average fuel consumption etc.

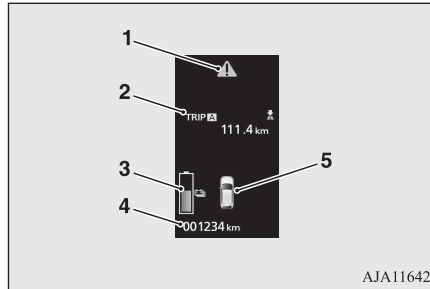

AJA116420

- 1- mark display screen → p. 6-11
- 2- Information screen → p. 6-07
Interrupt display screen → p. 6-10
- 3- Drive battery level display screen → p. 6-11
- 4- Odometer → p. 6-13
- 5- Door ajar warning display screen → p. 6-11

Refer to “Multi information display” on page 6-04.

EV switch

E08502400039

When you press the switch, you can drive the vehicle using only the EV drive mode as much as possible, even if the accelerator pedal is roughly depressed.

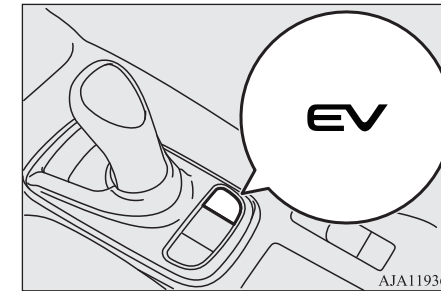

AJA119362

Refer to “EV switch” on page 7-25.

SAVE/CHARGE mode switch

E0850300029

If you press the switch with the operation mode of the power switch in ON, you can charge the drive battery mode in the order of SAVE, CHARGE, OFF, SAVE.

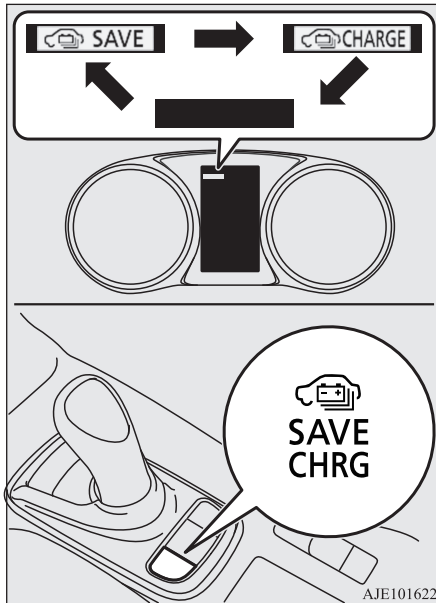

AJE101622

Refer to “SAVE/CHARGE mode switch” on page 7-28.

Battery save mode

When the READY indicator is illuminated, operate the SAVE/CHARGE mode switch to change the battery save mode. The engine will start in order to preserve the remaining power of the drive battery and the vehicle will operate in the series hybrid mode or the parallel hybrid mode depending on the remaining power in the drive battery.

Refer to “Battery save mode” on page 7-29.

Battery charge mode

When the READY indicator is illuminated, operate the SAVE/CHARGE mode switch to change the battery save mode. The engine will start to charge the drive battery to nearly full.

Refer to “Battery charge mode” on page 7-29.

S-AWC (Super-All Wheel Control)

E08501900170

S-AWC is an integrated vehicle dynamics control system that helps enhance driving performance, cornering performance, and vehicle stability over a wide range of driving conditions through integrated management of the twin motor 4WD, the AYC (Active Yaw Control), the ABS and the ASC.

Refer to “S-AWC (Super-All Wheel Control)” on page 7-20.

S-AWC drive mode

E08503200021

Select the drive mode from the following three types to suit the driving conditions.

Drive mode	Function
NORMAL	This mode can be used on both dry and wet roads. The distribution of driving/braking torque to each wheel is automatically controlled according to the driving condition.
SNOW	This mode is for driving on slippery road surfaces, such as snow-covered roads and improves stability on a slippery road.

Quick guide

1

Drive mode	Function
LOCK	This mode is for driving where maximum traction is required. This mode is suitable for driving on rough roads or driving in sand or fresh snow.

Refer to “S-AWC drive mode” on page 7-21.

Drive mode switch

E08503100020

When the operation mode of the power switch is put in ON, operate the drive mode switch (A) to change the drive mode.

When the operation mode is put in OFF, the drive mode will return to “NORMAL”.

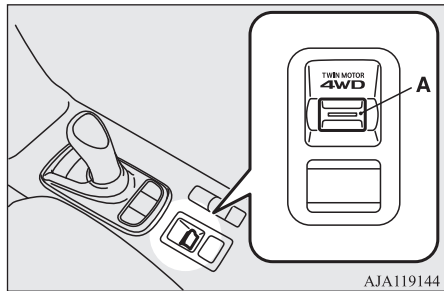

Refer to “Drive mode switch” on page 7-21.

SPORT mode switch

E08503300022

The SPORT mode switch is used when doing powerful sporty driving on mountain roads and uphill slope.

Quick acceleration in response to operation of the accelerator pedal and quick deceleration by strong regenerative braking force are possible.

The SPORT mode can be used when the SPORT mode switch is pressed while the READY indicator light is on.

To cancel, press the switch again or turn off the power mode.

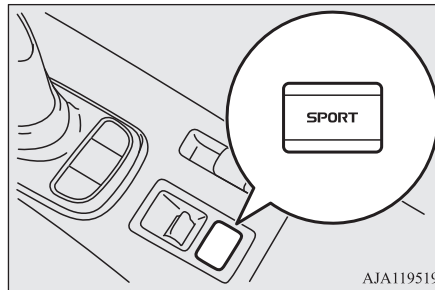

Refer to “SPORT mode switch” on page 7-31.

General information

Plug-in Hybrid EV System.....	2-02
Drive battery.....	2-05
EV cruising range.....	2-05
Acoustic Vehicle Alerting System (AVAS).....	2-06
Operating sound under charging or Remote Climate Control.....	2-06
In case of a collision.....	2-06
Inspection and maintenance.....	2-08
For persons with electro-medical apparatus such as im- plantable cardiac pacemaker or implantable cardiovert- er-defibrillator.....	2-09
Cautions and actions to deal with intense heat.....	2-10
Cautions and actions to deal with intense cold.....	2-10
Fuel selection.....	2-14
Filling the fuel tank.....	2-15
Installation of accessories.....	2-17
Modification/alterations to the electrical or fuel systems.....	2-18
Genuine parts.....	2-18
Safety and disposal information for used engine oil.....	2-18
Disposal information for used batteries.....	2-18

Plug-in Hybrid EV System

E00203500041

Main features

E00203600244

It is operated as an electric vehicle in the EV drive mode using the electrical power stored in the drive battery,*¹ according to the remaining amount of the drive battery. It is also automatic control*² for driving in series hybrid mode or parallel hybrid mode using engine power from EV drive mode according to the driving condition or if the charging level of the drive battery is decreased.

- With the high performance motor, noise and vibration during driving is minimized and powerful acceleration can also be obtained.
- With the regenerative brake, the drive battery is automatically charged when the accelerator is released.

*¹ If there is a remaining amount in the drive battery, it is actively driven in the EV drive mode. The cruising range varies depending on the remaining charge in the drive battery, vehicle speed, and air conditioner operating conditions.

*² You can adjust the timing to switch to the EV drive mode by using the save mode. Refer to “SAVE/CHARGE mode switch” on page 7-28. Refer to “Battery save mode” on page 7-29.

- The vehicle can be charged from EV charge power outlets (rated AC 220-240 V).
- Quick charging using the CHAdeMO quick charger is possible. CHAdeMO is a standard for quick charging of electric vehicles originally started in Japan, and the contents have also become international standard.

EV drive mode

- The vehicle is driven by the motors using only electrical power stored in the drive battery. However, EV drive mode is cancelled depending on the drive battery level, vehicle speed, and air conditioner operating conditions. Pay attention to the following points:
 - Check the EV cruising range in the information screen. Refer to “EV cruising range display/Total cruising range display” on page 6-15.
 - Drive your vehicle at moderate speeds avoiding quick acceleration/deceleration. Repeated quick acceleration/deceleration causes the drive battery level to decrease quickly, which extremely reduces the EV cruising range.

- If you want to drive the vehicle without starting the engine as much as possible, make the switch to the EV priority mode by pressing the EV switch. Refer to “EV switch” on page 7-25.

Series hybrid mode

- The vehicle is driven by the motors using only the electricity generated by the engine. This mode is used when the drive battery level is low, at quick acceleration, or when power is required like climbing uphill.

NOTE

- While driving the Series hybrid mode, the engine malfunction diagnostic system may operate. If this system operates, the engine sound will decrease. This does not indicate a malfunction.

Parallel hybrid mode

- The vehicle is driven by the power of the engine, assisted by motors. This mode is used during high-speed driving with better engine efficiency.

The roles of the motors and engine in each drive mode

	Motor	Engine
EV Drive Mode	Drives the vehicle	OFF
Series Hybrid Mode	Drives the vehicle	Generates electricity
Parallel Hybrid Mode	Drives the vehicle	Drives front wheels and generates electricity

Regenerative braking

Motion energy is converted into electric energy using the motor as a power generator. Then a braking force generates and converted electric energy will be charged to the drive battery.

- If you lift your foot off the accelerator pedal during driving, a braking force that is equivalent to engine braking of a combustion engine vehicle will be generated. Also, if you shift the select position into “B” (BRAKE) from “D” (DRIVE), effectiveness of the regenerative braking is getting stronger. Shift the selector lever into “B” (BRAKE) position according to the driving condition.

- When you depress the brake pedal, the regenerative braking force may be increased.
- If a problem occurs in the Plug-in hybrid EV system, or if the ABS and/or the ASC have been activated, the regenerative braking will be restricted. The foot brake will still operate.
- When stronger regenerative braking is generated, the stop lamps will illuminate even when the brake pedal is not depressed.

Operation of gasoline engine

E00203700098

- Even when the vehicle is driving in EV drive mode, it may be automatically changed to series hybrid mode or parallel hybrid mode in the following cases:
 - The plug-in hybrid EV system is too hot or too cold.
 - Quick acceleration is applied.
 - The air conditioner is operating.
 - The accelerator pedal is depressed hard on an uphill road or expressway.
 - In cold weather.
 - The vehicle has not been refueled for a long time.
 - The drive battery level is low.

In addition to the above, there are more cases where EV drive mode is automatically changed to series or parallel hybrid mode.

- Even while the vehicle is stopped, the engine may automatically be started in the following cases:
 - The drive battery level is low.
 - The plug-in hybrid EV system is too hot or too cold.
 - The air conditioner is used.
 - The vehicle has not been used for a long time.
 - The engine has not been operated for a long time.
 - Refuelling has not been performed for a long time.

2

NOTE

- Depending on the usage of the vehicle, the engine may not start for a long period of time and unused fuel will remain in the fuel tank. Fuel can deteriorate over time, which can adversely affect the engine and/or the fuel system.
If the vehicle is not refueled with more than 15 litres at least once every 3 months, the engine will automatically start, while the ready indicator is illuminated, to help prevent deterioration of the fuel. At that time, charging of the drive battery will start and the battery charge mode display will appear on the information screen in the multi information display. The charging will stop, however, before the drive battery is fully charged.
The engine may also start even while the EV drive mode is selected or the vehicle is stationary.
To stop the engine from starting automatically when the vehicle is operated on the drive battery power only for a long time, start the engine and drive the vehicle enough to reduce the fuel level to approximately half tank. Refill the fuel tank with at least 15 litres of unleaded petrol.

Refueling (gasoline)

E00203800073

CAUTION

- If the warning display appears, refuel immediately.
If the vehicle runs out of fuel, the engine will not start even in a situation need to be generated electricity, the following conditions will occur.
 - The driving performance falls (since only the electrical power stored in the drive battery can be used for the driving).
 - The heating performance is not available (except vehicles with electric heater).
 - The effectiveness of the heater is insufficient (vehicles with electric heater).
 - The catalytic converter may be damaged due to excessive high temperature.Refer to “Filling the fuel tank” on page 2-15.
Refer to “Fuel remaining display screen” on page 6-11.

CAUTION

- The fuel in the fuel tank may not be consumed and it may stagnate for a long time depending on the use situation of the vehicle, the quality of fuel may change, and it may have a bad influence on the engine or the parts of a fuel system.
Observe the following instructions for prevention.
 - Start the engine more than once every 3 months by activating the battery charge mode.
Refer to “SAVE/CHARGE mode switch” on page 7-28.
Refer to “Battery charge mode” on page 7-29.
 - Refill the fuel more than 15 litres at once within 3 months. If the fuel remaining display will be below half, you can refill the fuel more than 15 litres certainly.
Refer to “Fuel remaining display screen” on page 6-11.

Drive battery

E00205000066

WARNING

- A sealed lithium ion high voltage battery (drive battery) is adopted for OUTLANDER PHEV. If the drive battery is disposed of improperly, there is a risk of severe burns and electrical shock that may result in serious injury or death and there is also a risk of environmental damage.
- Never attempt to use the drive battery for any other purpose.

- It is the battery to operate the motor and the air conditioning.
In addition to the drive battery, OUTLANDER PHEV has the auxiliary battery to operate lamps, wipers, etc.
- Compact, light-weight lithium ion battery with high energy density is used for the drive battery.
- The drive battery has the following characteristics.
Please read this carefully paying attention to the following:

Characteristics

- The same as ordinary lithium-ion batteries, the battery capacity of the drive battery gradually reduces with time. As the drive battery capacity decreases, the initial EV cruising range and the vehicle performance will similarly decrease.
Depending on the usage conditions, such as frequent quick acceleration/deceleration, extremely hot weather, storing the vehicle in high ambient temperatures, etc., the rate of battery capacity drop will increase.
- The performance may be changed due to the ambient temperature.
At low ambient temperature, in particular, the EV cruising range is short and the charging time is long, compared to operation at normal temperature. Also, charging may be stopped before complete charging.
- When the ambient temperature lowers, the engine will start frequently, even if there remains much power in the drive battery.
- Because the engine starts frequently, the fuel consumption will increase.
- The battery is gradually discharged without use and the battery charge is lowered.
- It is not necessary to consume the battery completely before charging.

OGGE19E1

Precautions for operation

- If your vehicle is not used for a long time, check the drive battery level display every 3 months.
If the drive battery level display shows 0, charge the battery until some indication appears. Alternatively, start the Plug-in Hybrid EV System and turn on the ready indicator.
The engine will then automatically start to charge the drive battery.
Wait until the engine automatically stops, then put the operation mode of the power switch in OFF.
- MITSUBISHI Motors collects drive batteries. If you scrap your vehicle, please consult a MITSUBISHI MOTORS Authorized Service Point.

EV cruising range

E00205100025

- Even if the charge level is the same, the EV cruising range may vary depending on driving conditions. Since driving at high speed or climbing on a hill requires higher consumption of the drive battery than usual, the EV cruising range is shortened.

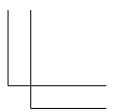
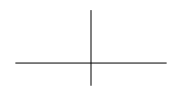
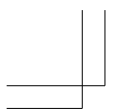

Acoustic Vehicle Alerting System (AVAS)

2

- Since the air conditioning (cooling or heating) consumes power of the drive battery, its operation results in a shorter EV cruising range. Maintain an appropriate temperature.
- Put the selector lever to “B” (BRAKE) position according to the road condition. To charge the drive battery with appropriate use of the regenerative brake, it can be increased the EV cruising range.

Acoustic Vehicle Alerting System (AVAS)

E00205200042

The Acoustic Vehicle Alerting System (AVAS) is a device that uses sound to alert pedestrians of the presence of the vehicle. The system operates when the vehicle speed is about 35 km/h (22 mph) or less and the engine is not running.

Refer to “Acoustic Vehicle Alerting System (AVAS)” on page 7-32.

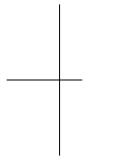

⚠ WARNING

- Even if the Acoustic Vehicle Alerting System (AVAS) sounds, pay special attention to pedestrians. Pedestrians may not notice the oncoming vehicle, which may cause an accident resulting in serious personal injury or death.

Operating sound under charging or Remote Climate Control

E00205700050

Even if the operation mode of the power switch is OFF, you may hear an operating sound such as the cooling fan for cooling the drive battery during charging, the air conditioning compressor and for remote climate control (if so equipped).

This is not a malfunction.

Refer to “MITSUBISHI Remote control: Remote Climate Control” on page 3-20.

In case of a collision

E00205300085

A crash or impact significant enough to require an emergency response for conventional vehicles would also require the same response for Outlander PHEV.

Also follow the instructions described below to avoid severe burns and electrical shock that may result in serious injury or death.

⚠ WARNING

- If your vehicle is drivable, pull your vehicle off the road to a safe, nearby location and remain on the scene. Also, if possible, do the following operations and stay out of the way of any oncoming traffic while awaiting the arrival of emergency responders.
 - Apply chocks to the wheels.
 - Put the select position in “P” (PARK) position.
 - Apply the parking brake.
 - Open the windows, doors and tailgate.
 - Put the operation mode in OFF.
 - Turn on the hazard warning flashers.
 - Move the key away from the vehicle to prevent unintended start-up of the system by inadvertent contact with a switch or impact from the crash.
- Never touch high-voltage wiring, connectors, and other high-voltage parts, such as the inverter unit and drive battery. An electric shock may occur if exposed electric wires are visible when viewed from inside or outside of your vehicle. For their locations, see “High-voltage components” on page 2-08.
- If the vehicle receives a strong impact to the floor while driving, stop the vehicle in a safe place and check the floor.

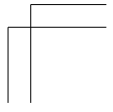
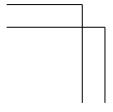
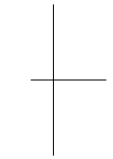

⚠ WARNING

- Never start the plug-in hybrid EV system if you found a leak of a liquid (except water of the air conditioner) while checking the outside of the vehicle because there is possibility the fuel system has been damaged and causing of fire or exploding. In such case, immediately contact your MITSUBISHI MOTORS Authorized Service Point.
- Leaks or damage to the drive battery may result in a fire. If you discover them, contact emergency services immediately. Since the fluid leak may be lithium manganese from the Lithium-ion battery, never touch any fluid leaking from the inside or outside of the vehicle. If the fluid contacts your skin or eyes, wash it off immediately with a large amount of water and receive immediate medical attention to help avoid serious injury.
- If you are unable to safely assess the vehicle due to vehicle damage, do not touch the vehicle. Leave the vehicle and contact emergency services. Advise emergency responders that this is a Plug-in Hybrid vehicle.

⚠ WARNING

- If a fire occurs in this vehicle, leave the vehicle as soon as possible and contact emergency services. Do not attempt to extinguish a fire by yourself. If the fire involves a lithium-ion battery, it will require large, sustained volumes of water for extinguishment. Using a small amount of water or the incorrect fire extinguisher can result in serious injury or death from electrical shock.
- When you leave the vehicle, if possible, open the windows, doors and tailgate to prevent accumulation of poisonous/combustible gasses. This will also assist in the rescue and fire fighting process.
- As with any vehicle fire, the byproducts of combustion can be toxic. Do not inhale smoke, vapors, or gas from the vehicle. Move to a safe distance upwind and uphill from the vehicle fire and out of the way of any oncoming traffic while awaiting the arrival of emergency responders.
- If you detect leaking fluids, sparks, smoke, flames, gurgling, popping or hissing noises originating from the high voltage battery compartment, contact emergency services immediately. This may result in a fire.
- Physical damage to the vehicle or high voltage battery may result in immediate or delayed release of toxic and/or flammable gases and fire.

⚠ WARNING

- If your vehicle needs to be towed, transport the vehicle on a flatbed truck or tow the vehicle with all wheels off the ground. If the any wheels are on the ground when towing, this may cause damage to the electric motors. This may also cause a fire, if wiring in the electric motor unit room becomes damaged. Refer to “Towing” on page 9-17.
- Do not attempt to repair a damaged Plug-in Hybrid vehicle by yourself. Please contact a MITSUBISHI MOTORS Authorized Service Point for service.
- In the event of an accident that requires body repair and painting, the vehicle should be delivered to a MITSUBISHI MOTORS Authorized Service Point to have the drive battery and high voltage parts such as the inverter, including the attached wiring harness, removed prior to painting. If exposed to heat in the paint booth, the drive battery will experience battery capacity loss. A damaged drive battery can also pose safety risks to untrained mechanics and repair personnel.

📖 NOTE

- The emergency shut-off system will be activated and the high-voltage system will automatically turn off under the following conditions:

Inspection and maintenance

2

NOTE

- Certain front, side or rear collisions.
- Certain Plug-in Hybrid EV system malfunctions.
- When the emergency shut-off system is activated, the ready indicator is turned off. Refer to “Indicator and warning lamp list” on page 6-24.
- If the emergency shut-off system activates, contact a MITSUBISHI MOTORS Authorized Service Point.

Inspection and maintenance

E00205400031

When performing inspection and maintenance, be careful in the following points.

WARNING

- Before performing inspection or maintenance, be sure to disconnect the charge connector from the vehicle and confirm that put the operation mode of the power switch in “OFF”.

WARNING

- Never touch, disassemble, remove or replace high-voltage parts, exposed electrical components, cables or connectors. Failure to follow this instruction can result in severe burns or electric shock causing serious injury or death. High-voltage cables are colored orange. The vehicle high-voltage system has no user serviceable parts. Take your vehicle to a MITSUBISHI MOTORS Authorized Service Point for any necessary maintenance.
- Never touch the service plug under the rear seat. Improper handling of this could cause an electric shock which result in a serious injury or death. The service plug is used to shut off the high voltage from the drive battery when repairing the vehicle at a MITSUBISHI MOTORS Authorized Service Point.

High-Voltage components

E00205500032

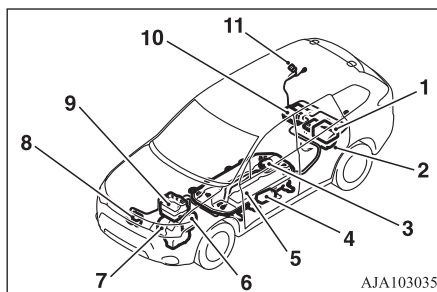

OGGE19E1

- 1- On board charger/DC-DC converter
- 2- Rear motor
- 3- Service plug
- 4- Electric heater*
- 5- Drive Battery
- 6- Front motor
- 7- Generator
- 8- Air conditioner compressor
- 9- Power drive unit (PDU)
- 10- Rear electric motor control unit (MCU)
- 11- Normal charge port/Quick charge port

WARNING

- The Plug-in Hybrid EV System uses high voltage up to DC 300 volt. The system can be hot during and after starting and when the vehicle is shut off. Be careful of both the high voltage and the high temperature. Follow the warning labels that are attached to the vehicle.
- Always assume the high voltage battery and associated components are energized and fully charged.
- Never perform servicing when READY indicator is illuminating or when the charging indicator is illuminating or flashing because the high-voltage system is operating.

For persons with electro-medical apparatus such as implantable cardiac pacemaker or implantable cardioverter-defibrillator

For persons with electro-medical apparatus such as implantable cardiac pacemaker or implantable cardioverter-defibrillator

2

E00205600075

WARNING

- **Before normal charging**
 - Before you perform charging work, ask the manufacturer of your electro-medical apparatus about the effect from charging work. Charging may affect the operation of your electro-medical apparatus.
Refer to “Normal charging (charging method with rated AC 220-240V outlet)” on page 3-10.
Refer to “Quick charging (charging method with quick charger)” on page 3-17.
- **When the normal charging**
 - Observe the following precautions for normal charging.
 - During charging, do not close the implantation portion of electro-medical apparatus such as implantable cardiac pacemaker or implantable cardioverter defibrillator to the charge connector, EV charging cable, control box and normal charging station.
 - Do not stay inside the vehicle.
 - Do not get in the vehicle (including the luggage compartment) to take out something or for other purposes.
Refer to “Normal charging (charging method with rated AC 220-240V outlet)” on page 3-10.
- **Do not perform quick charging and keep away from a quick charger**
 - Please observe the following precautions.
There is a possibility that electromagnetic waves affect the operation of the electro-medical apparatus.
 - Please do not use a quick charger.
 - Keep away as much as possible from the place where the quick charger is stored.
If you approach it carelessly, leave quickly without standing still.
 - Please ask someone to perform the quick charging if necessary.
Refer to “Quick charging (charging method with quick charger)” on page 3-17.
- **Do not bring your body close to the foot area of the rear seat and do not stay in the luggage compartment while the vehicle is running. Also, do not allow persons using an electro-medical apparatus to stay in the luggage compartment while the vehicle is running. The operation of electro-medical apparatus may be affected.**
- **When using the keyless operation system, please observe following precautions.**
 - People with implantable cardiac pacemakers or implantable cardiovascular-defibrillators should not go near the exterior transmitters (A) or the interior transmitters. The radio waves used by the keyless operation system could adversely affect implantable cardiac pacemakers or implantable cardiovascular-defibrillators.
 - When using electro-medical devices other than implantable cardiac pacemakers or implantable cardiovascular-defibrillators, contact the electro-medical device manufacturer ahead of time to determine the affects of radio waves on the devices. Electromedical device operations could be adverse effect by radio waves. Refer to “Keyless operation system” on page 4-06.

OGGE19E1

General information 2-09

Cautions and actions to deal with intense heat

Cautions and actions to deal with intense heat

E00203001128

2

- When the ambient temperature is approximately 45 °C or higher, the phenomena described below may occur. Please take the described action.
- Even if the ambient temperature is approximately 45 °C or lower, when performing quick charging, driving at high-speed and uphill repeatedly, the phenomena described below may occur. Please take the described actions.

Approx. ambient temperature	Phenomena		Corrective action
Approx. 45 °C or higher	Startup and driving	● The motor output is restricted and the vehicle performance may be decreased. Then, the “PROPULSION POWER IS REDUCED” warning display* may be displayed.	● Stop the vehicle at a safe place if needed with the plug-in hybrid EV system started.
	Charging and battery	● Charging time becomes longer, charging may not be possible or it may stop on the way.	● Park in a well-ventilated, shady place.

NOTE

- *: Refer to “PROPULSION POWER IS REDUCED warning display” on page 6-48. Display of the “PROPULSION POWER IS REDUCED” warning display does not indicate a malfunction.

Cautions and actions to deal with intense cold

E00203101288

- When the ambient temperature is approximately -15 °C or lower, the phenomena described below may occur. Please take the corrective actions described below.

Cautions and actions to deal with intense cold

Approx. ambient temperature	Phenomena		Corrective action
Approx. -15 °C or lower	Startup and driving	The motor output is restricted and the vehicle performance may be decreased. Then, the “PROPULSION POWER IS REDUCED” warning display* ¹ may be displayed.	Keep driving if you can drive at a safe speed. If you cannot drive at a safe speed, stop the vehicle in a safe place and charge the drive battery.
		Regenerative braking performance may decrease.	When braking, depress the brake pedal more strongly.
	Charging and battery	<ul style="list-style-type: none"> ● Charging times get longer. ● Complete charging may not be possible. 	When you have finished driving, charge the drive battery before the ambient temperature falls to -15 °C or lower.
Approx. -28 °C or lower	Startup and driving	The motor output is restricted and the vehicle performance may be decreased. Then, the “PROPULSION POWER IS REDUCED” warning display* ¹ and “BATTERY TOO COLD” warning display* ² may appear alternately. (Vehicles with drive battery warming system)	Keep driving if you can drive at the same speed as the surrounding vehicles. If you cannot drive at the same speed as the surrounding vehicles, stop the vehicle in a safe place.
		The vehicle performance decreases, the “BATTERY TOO COLD FOR VEHICLE TO OPERATE” warning display* ³ may appear.	In the daytime, wait for the temperature to rise. When the temperature in the vicinity of the drive battery has risen, start up.
	Startup and driving	Regenerative braking performance may decrease or be eliminated.	When braking, depress the brake pedal more strongly.
	Charging and battery	Charging may become impossible. (Except for vehicles with drive battery warming system)	When you have finished driving, charge the drive battery before the ambient temperature falls to -28 °C or lower.

2

Cautions and actions to deal with intense cold

2

Approx. ambient temperature	Phenomena		Corrective action
		<ul style="list-style-type: none"> ● Charging times get longer. ● Complete charging may not be possible. (Vehicles with drive battery warming system) 	If low temperature is predicted, even if the drive battery is fully charged, connect the EV charging cable. The drive battery will automatically be warmed.
Approx. -30 °C or lower	Startup and driving	The Plug-in Hybrid EV system may not be started and the “BATTERY TOO COLD” warning display*2 may appear. (Except for vehicles with drive battery warming system)	In the daytime, wait for the temperature to rise. When the temperature in the vicinity of the drive battery has risen, start up.
		The Plug-in Hybrid EV system may not start. The ready indicator*4 blinks and the “BATTERY TOO COLD PLUG IN NORMAL CHARGER TO WARM” warning display*5 may appear. (Vehicles with drive battery warming system)	If low temperature is predicted, even if the drive battery is fully charged, connect the EV charging cable (normal charger). The drive battery will automatically be warmed. The Plug-in Hybrid EV system can be started within 1 hour after the EV charging cable is connected.
		Regenerative braking performance may decrease or be eliminated.	When braking, depress the brake pedal more strongly.
		The vehicle performance decreases, the “BATTERY TOO COLD FOR VEHICLE TO OPERATE” warning display*3 may appear.	Immediately stop the vehicle in a safe place. In the daytime, wait for the temperature to rise. When the temperature in the vicinity of the drive battery has risen, start up.

Cautions and actions to deal with intense cold

Approx. ambient temperature	Phenomena		Corrective action
	Charging and battery	Charging may become impossible. When charging is interrupted, the operation mode is automatically turned off.*6 (Except for vehicles with drive battery warming system)	In the daytime, wait for the temperature to rise. When the temperature in the vicinity of the drive battery has risen, begin charging.
		<ul style="list-style-type: none"> ● Charging times get longer. ● Complete charging may not be possible. (Vehicles with drive battery warming system) 	If low temperature is predicted, even if the drive battery is fully charged, connect the EV charging cable. The drive battery will automatically be warmed.

2

⚠ CAUTION

- When “BATTERY TOO COLD FOR VEHICLE TO OPERATE” is displayed*3, contact a MITSUBISHI MOTORS Authorized Service Point.

Fuel selection

2

NOTE

- *1: Refer to “PROPULSION POWER IS REDUCED warning display” on page 6-48.
Display of the “PROPULSION POWER IS REDUCED” warning display does not indicate a malfunction.
- *2: Refer to “BATTERY TOO COLD warning display” on page 6-26.
- *3: Refer to “BATTERY TOO COLD FOR VEHICLE TO OPERATE” warning display” on page 6-26.
- *4: Refer to “Ready indicator” on page 6-55.
- *5: Refer to “BATTERY TOO COLD PLUG IN NORMAL CHARGER TO WARM warning display” on page 6-26.
- *6: Refer to “Automatic OFF of operation mode” on page 7-13.
- To warm up the drive battery, you need to register your wireless LAN device (which conforms to IEEE 802.11 b and iOS or Android) to your vehicle by MITSUBISHI Remote Control (if so equipped).
If the information of “” mark on the wireless LAN device is displayed, connect the EV charging cable as soon as possible. Refer to “MITSUBISHI Remote Control” on page 3-20.
- When warming the drive battery with the drive battery warming system (if so equipped), use the EV charging cable. When using a home charging device or a public charging device (EVSE: Electric Vehicle Supply Equipment), charging and warm-up of the drive battery may be stopped. If this happens, disconnect the charge connector and insert the charge connector again.
Accordingly, the drive battery warming system will be reactivated and you can start the Plug-in Hybrid EV system within 1 hour.
- The drive battery warming system may not be activated depending on the situation.
- While warming up the drive battery, the following phenomena may occur.
 - The operation sound of on board equipment and the state of charge is displayed on the multi-information display.
Refer to “Charging from rated AC 220-240 V outlet” on page 3-12.
 - Inside of the vehicle may be heated automatically.
 - The drive battery may not become full charge, or the remaining capacity of drive battery may decrease.

Fuel selection

E00200105344

Recom- mended fuel	Unleaded petrol octane number (EN228) 95 RON or higher
--------------------------	--

CAUTION

- The use of leaded fuel can result in serious damage to the engine and catalytic converter. Do not use leaded fuel.

NOTE

- Poor quality petrol can cause problems such as difficult starting, stalling, engine noise and hesitation. If you experience these problems, try another brand and/or grade of petrol.

If the check engine warning lamp flashes, have the system checked as soon as possible at a MITSUBISHI MOTORS Authorized Service Point.

Graphical expression for consumer information



E5: Petrol fuel containing up to 2.7 % (m/m) oxygen or up to 5.0 % (V/V) ethanol – Eg. EN 228 compliant unleaded petrol
 E10: Petrol fuel containing up to 3.7 % (m/m) oxygen or up to 10.0 % (V/V) ethanol – Eg. EN 228 compliant unleaded petrol
 The petrol engine are compatible with E5 type petrol (containing 5 % ethanol) and E10 type petrol (containing 10 % ethanol) conforming to European standards EN 228.

CAUTION

- Do not use more than 10 % concentration of ethanol (grain alcohol) by volume. Use of more than 10 % concentration may lead to damage to your vehicle fuel system, engine, engine sensors and exhaust system.

Filling the fuel tank

E00200204612

WARNING

- When handling fuel, comply with the safety regulations displayed by garages and filling stations.
- Gasoline is highly flammable and explosive. You could be burned or seriously injured when handling it. When refueling your vehicle, always put the operation mode of the power switch in OFF and keep away from flames, sparks, and smoking materials. Always handle fuel in well-ventilated outdoor areas.
- Before removing the fuel cap, be sure to get rid of your body's static electricity by touching a metal part of the car or fuel pump. Any static electricity on your body could create a spark that ignites fuel vapour.

WARNING

- Perform the whole refueling process (opening the fuel tank filler door, removing the fuel cap, etc.) by yourself. Do not let any other person come near the fuel tank filler. If you allowed a person to help you and that person was carrying static electricity, fuel vapour could be ignited.
- Do not perform charging and refueling at the same time. If you charged with static electricity, fuel vapour could be ignited by the discharge spark.
- Do not move away from the fuel tank filler until refueling is finished. If you moved away and did something else (for example, sitting on a seat) part-way through the refueling process, you could pick up a fresh charge of static electricity.
- Be careful not to inhale fuel vapour. Fuel contains toxic substances.
- Keep the doors and windows closed while refueling the vehicle. If they were open, fuel vapour could get into the cabin.
- If the tank cap must be replaced, use only a MITSUBISHI MOTORS genuine part.

CAUTION

- The fuel in the fuel tank may not be consumed and it may stagnate for a long time depending on the use situation of the vehicle, the quality of fuel may change, and it may have a bad influence on the engine or the parts of a fuel system.

Filling the fuel tank

2

CAUTION

Observe the following instructions for prevention.

- Activate the battery charge mode in order to start the engine at least once every three months.
Refer to “Battery charge mode” on page 7-29.
- Refill the fuel more than 15 litres at once within three months. If the fuel remaining display will be below half, you can refill the fuel more than 15 litres certainly.
Refer to “Fuel remaining display screen” on page 6-11.

Fuel tank capacity

45 litres

Refueling

1. Before filling with fuel, stop the plug-in hybrid EV system.
2. The fuel tank filler is located on the rear left side of your vehicle.

Open the fuel tank filler door by pulling the release lever located on the side of the driver's seat.

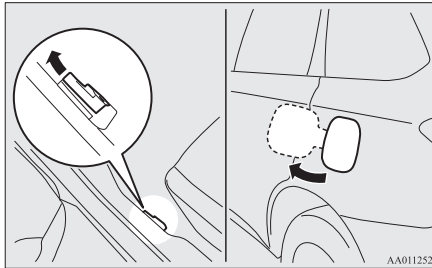

3. Open the fuel tank filler tube by slowly turning the cap anticlockwise.

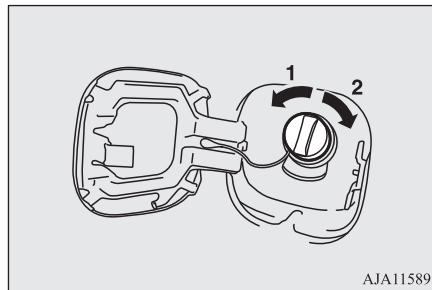

- 1- Remove
- 2- Close

CAUTION

- Since the fuel system may be under pressure, remove the fuel tank filler tube cap slowly. This relieves any pressure or vacuum that might have built up in the fuel tank. If you hear a hissing sound, wait until it stops before removing the cap. Otherwise, fuel may spray out, injuring you or others.

NOTE

- While filling with fuel, hang the fuel cap on the hook (A) located on the inside of the fuel tank filler door.

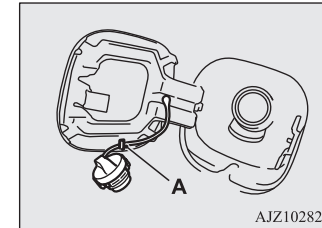

4. Insert the gun in the tank port as far as it goes.

CAUTION

- Do not tilt the gun.

5. When the gun stops automatically, do not fill with fuel any more.
6. To close, turn the fuel cap slowly clockwise until you hear clicking sounds, then gently push the fuel tank filler door closed.

Installation of accessories

E00200302635

We recommend you to consult your MITSUBISHI MOTORS Authorized Service Point.

CAUTION

- Your vehicle is equipped with a diagnosis connector for checking and servicing the electronic control system. Do not connect a device other than a diagnosis tool for inspections and service to this connector. Otherwise, the auxiliary battery could be discharged, the electronic devices of the vehicle could malfunction, or other unexpected problems could result. In addition, malfunctions caused by connecting a device other than a diagnosis tool may not be covered under warranty.

- The installation of accessories, optional parts, etc., should only be carried out within the limits prescribed by law in your country, and in accordance with the guidelines and warnings contained within the documents accompanying this vehicle.
- Installing electric components incorrectly could lead to a fire. Refer to the “Modification/alterations to the electrical or fuel systems” section within this owner’s manual.
- When installing the radio, for the required information (frequency, transmission output, installing procedure), consult a MITSUBISHI MOTORS Authorized Service Point. If the frequency, transmission output and installing condition are not appropriate, it can adversely affect the electronic devices and could lead to unsafe vehicle operation.
- Using a cellular phone or radio set inside the vehicle without an external antenna may cause electrical system interference, which could lead to unsafe vehicle operation.
- Tyres and wheels which do not meet specifications must not be used. Refer to the “Specifications” section for information regarding wheel and tyre sizes.

Important points!

Due to large number of accessory and replacement parts of different manufactures available in the market, it is not possible, not only for MITSUBISHI MOTORS, but also for a MITSUBISHI MOTORS Authorized Service Point, to check whether the attachment or installation of such parts affects the overall safety of your vehicle.

Even when such parts are officially authorized, for example by a “general operators permit” (an appraisal for the part) or through the execution of the part in an officially approved manner of construction, or when a single operation permit following the attachment or installation of such parts, it cannot be deduced from that alone, that the driving safety of your vehicles has not been affected.

Consider also that there basically exists no liability on the part of the appraiser or the official. Maximum safety can only be ensured with parts recommended, sold and fitted or installed by a MITSUBISHI MOTORS authorized Service Point (MITSUBISHI MOTORS GENUINE replacement parts and MITSUBISHI MOTORS accessories). The same also pertains to modifications of vehicles with respect to the production specifications. For safety reasons, do not attempt any modifications other than those that follow the recommendations of a MITSUBISHI MOTORS authorized Service Point.

2

Modification/alterations to the electrical or fuel systems

2

Modification/alterations to the electrical or fuel systems

E00200401583

MITSUBISHI MOTORS CORPORATION has always manufactured safe, high quality vehicles. In order to maintain this safety and quality, it is important that any accessory that is to be fitted, or any modifications carried out which involve the electrical or fuel systems, should be carried out in accordance with MITSUBISHI MOTORS guidelines.

CAUTION

- If the wires interfere with the vehicle body or improper installation methods are used (protective fuses not included, etc.), electronic devices may be adversely affected, resulting in a fire or other accident.

Genuine parts

E00200500499

MITSUBISHI MOTORS has gone to great lengths to bring you a superbly crafted automobile offering the highest quality and dependability.

Use MITSUBISHI MOTORS GENUINE Parts, designed and manufactured to maintain your MITSUBISHI MOTORS automobile at top performance. MITSUBISHI MOTORS GENUINE Parts are identified by this mark and are available at all MITSUBISHI MOTORS Authorized Service Points.

**MITSUBISHI MOTORS
GENUINE PARTS**

Safety and disposal information for used engine oil

E00200601383

WARNING

- Prolonged and repeated contact may cause serious skin disorders, including dermatitis and cancer.
- Avoid contact with the skin as far as possible and wash thoroughly after any contact.
- Keep used engine oils out of reach of children.

Protect the environment

It is illegal to pollute drains, water courses and soil. Use authorized waste collection facilities, including civic amenity sites and garages providing facilities for disposal of used oil and used oil filters. If in doubt, contact your local authority for advice on disposal.

Disposal information for used batteries

E00201301055



Your vehicle contains batteries and/or accumulators. Do not mix with general household waste. For proper treatment, recovery and recycling of used

batteries, please take them to applicable collection points, in accordance with your national legislation and the Directives 2006/66/EC.

By disposing of these batteries correctly, you will help to save valuable resources and prevent any potential negative effects on human health and the environment which could otherwise arise from inappropriate waste handling.

Charging

3

Charging.....	3-02
Battery.....	3-04
Basic knowledge for charging.....	3-04
EV charging cable*.....	3-07
Normal charging (charging method with rated AC 220-240V outlet).....	3-10
Quick charging (charging method with quick charger).....	3-17
MITSUBISHI Remote Control*.....	3-20
How to use an electric device during charging.....	3-24
Charging troubleshooting guide.....	3-28

Charging

Charging

E08303801282

3

Your vehicle is equipped with a charge port and a charging cable (EV charging cable)*¹ for charging with a AC 220-240 V outlet. You can also charge your vehicle using 220-240 V home or public charging device (EVSE)*² compatible with OUTLANDER PHEV. Your vehicle come equipped with an additional quick charge port to be used with a CHAdeMO quick charger.

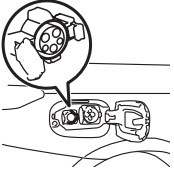
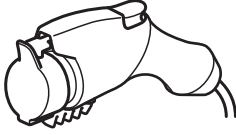
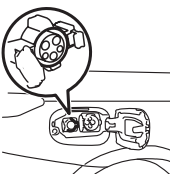
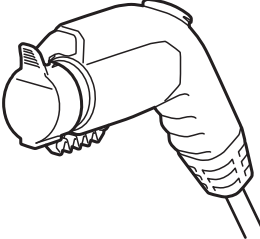
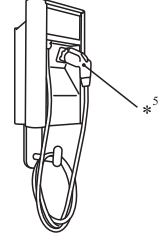
Category	Charge port	Charge connector	Charging Source	Charging time with fully discharged battery* ³	Reference
Normal charging (AC 220-240 V) When using a genuine charging cable* ¹	 Right rear side of vehicle		220-240 V household outlet (Refer to “Charging from rated AC 220-240 V outlet” on page 3-12)	230 V/10 A: Approximately 5.5 hours 230 V/8 A: Approximately 7 hours	3-10
Normal charging (AC 220-240 V) When using a home or public charging device (EVSE)* ²	 Right rear side of vehicle		 Home or public charging device	230 V/16 A: Approximately 4 hours	3-10

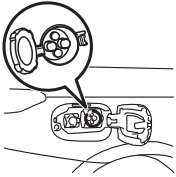
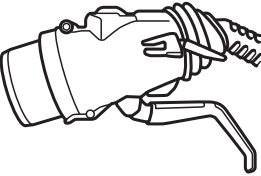
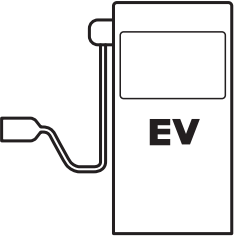
Category	Charge port	Charge connector	Charging Source	Charging time with fully discharged battery*3	Reference
Quick charging (charging method with quick charger)	 <p>Right rear side of vehicle</p>		 <p>Public charging stations where available</p>	Approximately 25 minutes for 80 % charge	3-17

3

*1: Optional equipment

*2: EVSE = Electric Vehicle Supply Equipment

*3: Use this time as a guide because the rated AC voltage and the rated current value may differ from country to country.

Also, charging time will vary depending on the condition of the drive battery, air temperature, electric power consumption of electrical devices during charging and condition of the power source. (such as specifications of the quick charger)

*4: The charging time will vary depending on the condition of the main drive lithium-ion battery, air temperature, electric power consumption of electrical devices and condition of the power source (such as specification of the quick charger).

*5: When using an EVSE to which charging cable is not attached, use a Mode 3 charging cable for OUTLANDER PHEV (Type 2 to 1) -available separately. For details, please consult a MITSUBISHI MOTORS Authorized Service Point.

Battery

NOTE

- The drive battery can be charged to nearly full using the battery charge mode switch. Refer to “SAVE/CHARGE mode switch” on page 7-28. Refer to “Battery save mode” on page 7-29.

3

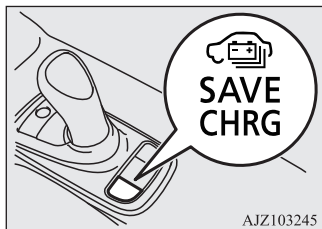

Battery

E08300101079

There are two types of batteries installed in your vehicle: a drive battery for operating the motor (electric motor unit) and air conditioning as well as an auxiliary battery for starting the Plug-in Hybrid EV system and operating the lamps, wipers, etc.

This chapter explains charging of the drive battery.

NOTE

- The auxiliary battery is automatically charged while the ready indicator is illuminated or during charge for the drive battery. Refer to “Ready indicator” on page 6-55.
- If the auxiliary battery is flat, the Plug-in Hybrid EV system cannot be started. Refer to “Emergency starting” on page 9-02.

Basic knowledge for charging

E08300201285

There are two types of charging: normal charging and quick charging.

Normal charging is performed through the on board charger using rated AC 220-240V outlet as the power source
The rated AC voltage may differ from country to country.

⚠ WARNING

- To reduce the risk of electric shock or fire due to electric leak, always use an earthed outlet protected by a residual current detector, rated for amperage equal to or greater than the value specified by MITSUBISHI MOTORS, and that is connected to a dedicated branch circuit. If the circuit is shared, and another electrical device is being used at the same time as the vehicle is charging, the circuit may heat abnormally, the breaker may trip and the circuit may cause adverse interference on the household electrical appliances such as TVs and audio systems.
- It is possible to charge even in rain or snow. However, be sure to pay attention to the following:
 - Do not touch normal charge port, normal charge connector, outlet and plug with wet hands.
 - Keep away from water when connecting the normal charge port, normal charge connector, outlet and plug.
 - Do not perform the charging in the out of doors when heavy rain, heavy snow, strong winds, and when bad weather is expected.
 - Do not charge if there is possibility a lightning strike. When thunder rumbling begins suddenly during normal charging, do not touch the vehicle and the EV charging cable and turn off the breaker.

⚠ WARNING

- If water goes into the normal charge port or the normal charge connector, it could cause a short circuit, a fire and an electric shock.
Be sure to completely close the charging lid and the inner lid and do not leave the EV charging cable in an outdoors.
- If the connected part of the charging plug has been buried in snow while charging, turn off the hand switch or the breaker connected with the outlet first, then remove the snow and disconnect the charging plug. If your vehicle body has been buried in snow while charging, remove the snow and then disconnect the charge connector.
- When you perform the normal charging at away from home, some normal chargers may not correspond to your vehicle. Consult an administrator or a maker of the normal charger that it corresponds to your vehicle before using it. Also perform normal charging according to the operating procedure indicated on the body of normal charger.
- Do not open the charging lid for anything other than charging and using the external power feed.

⚠ CAUTION

- Do not attempt to perform a jump start on the auxiliary battery at the same time that the drive battery is being charged. Doing so may damage the vehicle or charging cable and could cause injury.
Refer to “Emergency starting” on page 9-02.

📖 NOTE

- If you open the charging lid with the operation mode of the power switch is ON, a buzzer sounds approximately 10 minutes intermittently to alert the charging cannot be started. If you close the charging lid or put the operation mode in OFF, the buzzer stops.
- If you insert the charge connector to the charge port with the operation mode is ON, a buzzer sounds continuously approximately 10 minutes to alert the charging cannot be started.
If you pull the charge connector out or put the operation mode in OFF, the buzzer stops.
- Repeatedly performing only quick charging may reduce the battery capacity.
In usual charge, normal charging is recommended.
- To maintain the capacity of the drive battery, the following is recommended:
 - If you repeatedly perform only the quick charging, fully charge the vehicle in normal charging every 2 weeks.

Basic knowledge for charging

NOTE

3

- Do not repeat charging near the full charge level.
- The quick charging gives priority when the normal charging and the quick charging are performed at the same time. At this time, the normal charging will be stopped.
- Even if the operation mode of the power switch is OFF, you may hear the operating sound of the cooling fan for cooling the drive battery during charging. This is not a malfunction.
- If your vehicle is not used for a long time, check the energy level gauge every 3 months. If the gauge shows 0, charge the drive battery until some indication appears. Alternatively, start the Plug-in Hybrid EV System. Then the engine will automatically start to charge the drive battery. Wait until the engine automatically stops, then put the operation mode of the power switch in OFF.
- In the event of an electrical power outage while charging, charging restarts automatically with the restoration of electricity.

Charge port courtesy lamp

E08304300157

The charging port courtesy lamp (A) illuminates when the charging lid is opened while the select position is in "P" (PARK) position. It goes off automatically after approximately 3 minutes.

If you want to turn on it again, press the charging port courtesy lamp switch (B).

3-06 Charging

When charging is started, the charging port courtesy lamp blinks three times.

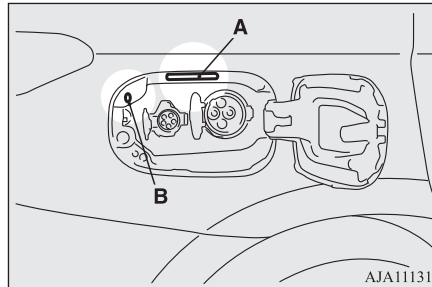

NOTE

- The charging port courtesy lamp illuminating time can be adjusted. For details, please consult a MITSUBISHI MOTORS Authorized Service Point.
- If the MITSUBISHI Remote Control (if so equipped) is operated when the charging port courtesy lamp is off, the lamp may illuminate.

OGGE19E1

EV charging cable*

E08301101223

Your vehicle is equipped with an EV charging cable that consists of a cable (A), control box (B), EV charging cable plug (C), and normal charge connector (D).

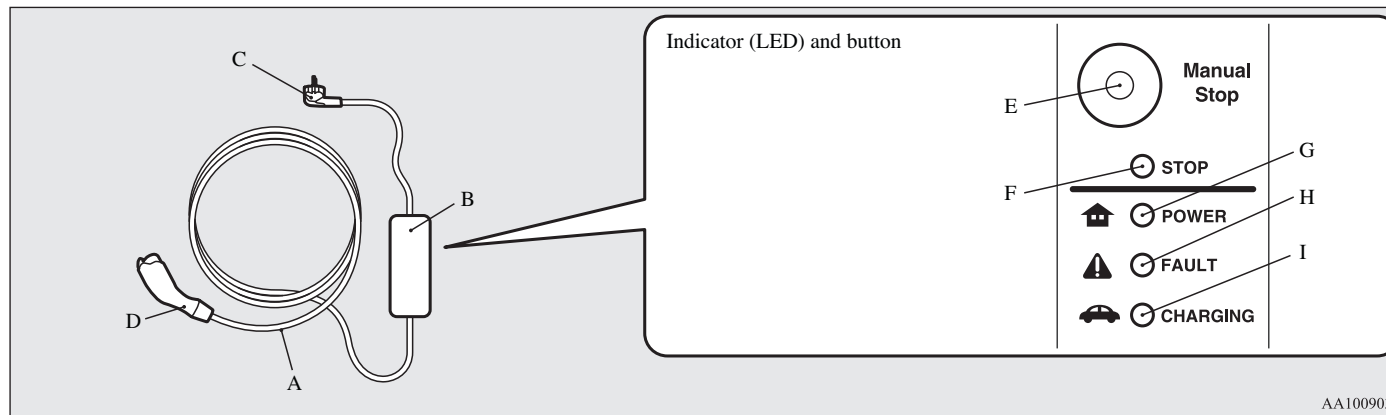
3

AA1009037

E- Manual stop button
F- Stop indicator

G (🏠)- POWER indicator
H (⚠️)- FAULT indicator
I (🚗)- CHARGING indicator

To stop charging, simply press manual stop button (E) and stop indicator (F) is illuminated. Re-connect the EV charging cable plug (C) to charge again.

POWER (G), FAULT (H) and CHARGING (I) indicators located on the control box will illuminate/blink in response to the following conditions:

EV charging cable*

○: Illuminates ◎: Blinking ●: Not illuminates

3

POWER 🏠	FAULT ⚠️	CHARGING 🚗	Operating condition
○	○	○	Every time the charging cable plug (C) is connected to an outlet, all indication lamps illuminate for 0.5 seconds.
○	●	●	After initial processing is completed, when the normal charge connector is not connected to the charge port, or the normal charge connector is connected to the charge port but charging is not being performed.
○	●	○	While the drive battery is being charged.
○	●	◎	When charging is completed.

POWER 🏠	FAULT ⚠️	CHARGING 🚗	Abnormal operating condition and corrective action
○	◎	●	When an electric leakage occurs or the EV charging cable malfunctions Stop using the EV charging cable immediately and contact a MITSUBISHI MOTORS Authorized Service Point.
○	○	●	When the EV charging cable malfunctions Stop using the EV charging cable immediately and contact a MITSUBISHI MOTORS Authorized Service Point.
●	●	●	If the control box indication lamp does not illuminate after connecting the charging cable plug to the outlet, check the circuit breaker for the outlet. If the breaker has tripped, the circuit may not be suitable for use with EV charging cable. You should have a licensed electrician inspect and repair the electrical circuit. If the breaker is not tripped, stop using the EV charging cable and contact a MITSUBISHI MOTORS Authorized Service Point.

 **WARNING**

- If the **POWER** or **CHARGING** indicator does not illuminate or the **FAULT** indicator blinks or illuminates during normal charging, please contact a MITSUBISHI MOTORS Authorized Service Point.
- Do not charge when the EV charging cable is coiled up.
The cable may be heated abnormally and resulting in fire.
- Do not alter or disassemble the EV charging cable. Doing so could cause fire, an electric shock or injury.
- Be sure to install the cap to the normal charge connector and store the EV charging cable in a place where the cable is not exposed to water or dust. Entry of foreign matter such as water or dust in the metal terminal of the normal charge connector or charging cable plug may cause a fire or malfunction.
- Never force the connection if the EV charging cable or connector shows damage or is not easily connected due to foreign material entering the connector or the outlet. And never use an outlet that is worn, damaged, or will not hold the plug firmly. Doing so could cause fire, an electric shock, or short circuit.
- Pay attention to the following for handling the EV charging cable.
Damage to the cable could cause fire, an electric shock, or short circuit.
 - Do not drop the cable or do not give strong impact to it.
 - Do not pull or bend with undue force.
 - Do not twist.
 - Do not drag.
 - Do not put an object on top.
 - Do not put the cable close to a heating unit including heater.

3 **CAUTION**

- Do not connect the normal charge cable to an outlet that has a lower rating than the current value described on the control box.

 **NOTE**

- All indicators are illuminated momentarily for confirming operation when the charging cable plug is inserted into an outlet. After that the **POWER** indicator and the **CHARGING** indicator is continuously illuminated.
- The **CHARGING** indicator will start to blink when the charging is completed. The **POWER** indicator is continuously illuminated while the charging cable plug is inserted into an outlet.

Normal charging (charging method with rated AC 220-240V outlet)

Handling and storing the control box

E08301201093

3

CAUTION

- While charging, prevent damage to the control box by attaching a rope as shown in the following illustration.

NOTE

- Use a hook with a load capacity over 4 kg.
- Check that the rope and hook have no damage and are not loose before use.

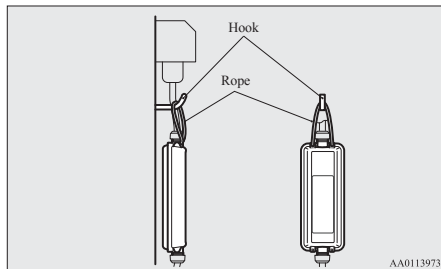

Cleaning the EV charging cable

E08301301065

1. Lightly wipe these off with a soft cloth soaked in a mild soap and water solution.

2. Wipe off all the detergent with a soft cloth dipped in fresh water and thoroughly wrung out.
3. Wipe all moisture off and dry in a shaded, well-ventilated area.

WARNING

- When cleaning, be sure to remove the charging cable plug and the normal charge connector from the outlet. Do not connect or disconnect the plug and the connector with wet hands. Doing so could cause an electric shock.
- Do not expose the metal terminal of the normal charge connector or the charging cable plug to water or neutral detergent. Using in wet with water could cause a fire or an electric shock.

CAUTION

- Never use benzine, petrol, or other organic solvents, or acid or alkaline solvents. Doing so could cause deformation, discoloration, or malfunction. Also, these substances may be present in various cleaners, so check carefully before using.

Normal charging (charging method with rated AC 220-240V outlet)

E08300901312

WARNING

- For safety, do not allow children or people who are not familiar with charging to charge for themselves. Also, do not use the normal charge connector within reach of children.
- Persons who use electro-medical apparatus such as implantable cardiac pacemaker or implantable cardioverter defibrillator must check effect from charging with the manufacturer of electro-medical apparatus. Electro-medical apparatus operations could be affected by charging.
- If you use electro-medical apparatus such as implantable cardiac pacemaker or implantable cardioverter-defibrillator, be careful the following precautions.
 - During charging, do not allow implanted electro-medical apparatus such as cardiac pacemaker or implantable cardioverter defibrillator to be close to the charge connector, EV charging cable, control box and normal charging station.
 - Do not stay inside the vehicle.
 - Do not get in the vehicle (including the luggage compartment) to take out something or for other purposes.

Normal charging (charging method with rated AC 220-240V outlet)

⚠ WARNING

- Do not open the tailgate, for example to remove or place an item in the cargo area.
Charging may affect the operation of electric medical devices and result in serious personal injury or death.
- Do not charge when the EV charging cable is coiled up.
Doing so the cable may be heated abnormally and this might result in fire.
- Before charging, make sure that there is no foreign matter such as dust at the normal charge port and the normal charge connector.
At this time, do not touch the normal charge port.
- When the normal charge connector is connected to the charge port, prevent foreign matter such as water or dust from entering in the connection.
Connection with foreign matter such as water or dust may cause fire or an electric shock. Do not perform charging if there might be strong exposure to water at the connection.
- Never pull the cable to remove the plug.
And never submerge the EV charging connector, control box or plug in water.
- Please observe the following in order to prevent accidents during charging such as electrocution.
 - Only use the EV charging cable that is supplied with the vehicle.

⚠ WARNING

- Do not charge another vehicle by the EV charging cable. The cable may overheat and this may result in a fire.
- When charging outdoors, make sure to use an outlet that is protected from water entering.
- Do not perform charging with the vehicle covered by a car cover, except for the MITSUBISHI MOTORS GENUINE car cover.
- Do not connect or disconnect the plug and connector with wet hands.
- While it is normal for the connector and charging cable to become warm during charging, discontinue use immediately if the connector or charging cable becomes hot to the touch.
- While it is normal for the control box to become warm during charging, discontinue use immediately if the control box becomes hot to the touch.
- If abnormal smells are detected or the vehicle produces smoke, quickly stop charging.
- Do not perform charging in a poorly ventilated area or in an enclosed area. Keep sparks, cigarettes, and flames away from the auxiliary battery.
Flammable gas generated from the auxiliary battery during charging may be trapped, resulting in explosion.
If charging is inevitably required, ventilate the area well.

⚠ WARNING

- Grasp the normal charge connector when connecting or disconnecting the EV charging cable.
Grasping the cable may damage the cable and could cause an electric shock, short circuit, and/or fire.

3

⚠ CAUTION

- During charging, the cooling fans inside the engine compartment may automatically be operated even if the operation mode of the power switch is in OFF.
Keep your hands away from the cooling fan during charging.
- Do not perform charging from other power source like a generator. Doing so could cause a malfunction.

📖 NOTE

- If the charge connector is not easily connected to the charge port due to foreign material entering, never force the connection. Doing so could damage the charging equipment or the vehicle. Please contact a MITSUBISHI MOTORS Authorized Service Point.
- The on board charger is only for rated AC 220-240V outlets.

Normal charging (charging method with rated AC 220-240V outlet)

NOTE

- When connecting or disconnecting the normal charge connector, insert/pull out the connector straight. Also, do not incline or twist the connector. Doing so could cause a bad connection or malfunction.
- Make sure to lock the doors to prevent theft, etc. during charging.
- Do not push the rear portion of the charging lid when the charging lid is locked. There is a possibility that the charging lid opens unexpectedly when the doors are unlocked while using the central door locks, keyless entry system or keyless operation function.

Charging from rated AC 220-240 V outlet

E08301001411

1. Firmly apply the parking brake, press the electrical parking switch to shift into the "P" (PARK) position and put the operation mode of the power switch in the "OFF" position.
2. Unlock the driver's door to unlock the charging lid.
3. Push the rear portion of the charging lid (A) until it clicks, and open the charging lid.

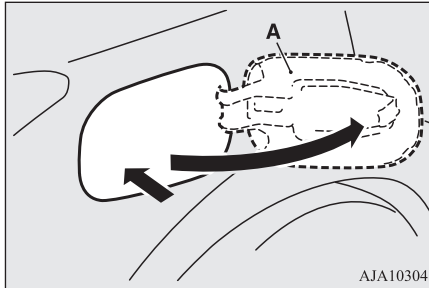

NOTE

- The charging lid is unlocked in conjunction with unlocking of the driver's door as the following condition.
 - The operation mode is put in "OFF" or "ACC".
 - The selector lever position is "P" (PARK).
- When the charging lid cannot be unlocked even if the driver's door is unlocked. Open the charging lid manually by using the release lever inside of the interior trim in the luggage compartment. Refer to "If the charging lid cannot be unlocked" on page 3-16.

4. Press the tab (B) to open the inner lid (C).

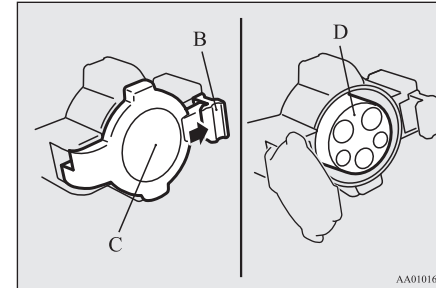

WARNING

- It could cause electric leak, a fire or electric shock by entering water or dust into the normal charge port.
- Do not touch the metal terminal of the normal charge port (D) and the normal charge connector. Doing so could cause an electric shock and/or malfunction.

NOTE

- There is a hole on the charge port for water drainage. If this hole is blocked and water gets trapped in the charge port, do not charge. Please contact a MITSUBISHI MOTORS Authorized Service Point.
- If the charge port is frozen, melt the ice using a hair drier. Forcing the charge connector to connect while frozen could result in malfunction.

Normal charging (charging method with rated AC 220-240V outlet)

5. Insert the charging cable plug into an outlet.

WARNING

- Make sure that the plug is inserted all the way into the outlet before use. If charging is continued in the state where it is not fully inserted the plug, there is a possibility of generating abnormal heat and resulting in a fire.
- To prevent an electric shock or fire due to an electric leak, perform charging using a waterproofed outlet with earthing which is connected to an earth leakage circuit breaker.
- To reduce the risk of electric shock or fire due to electric leak, always use an earthed outlet protected by a residual current detector, rated for amperage equal to or greater than the value specified by MITSUBISHI MOTORS, and that is connected to a dedicated branch circuit. If the circuit is shared, and another electrical device is being used at the same time as the vehicle is charging, the circuit may heat abnormally, the breaker may trip and the circuit may cause adverse interference on the household electrical appliances such as TVs and audio systems.

WARNING

- Never use an extension cable, multi-plug adapter or conversion adapter. Using them may cause abnormal overheating resulting in a fire.

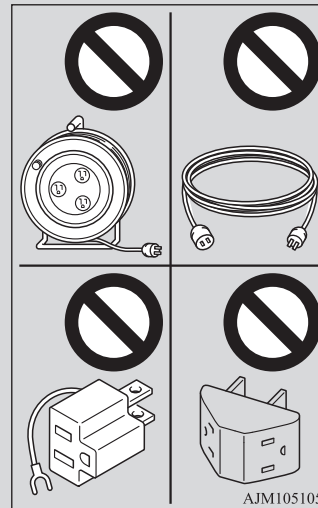

- Do not use a multi type outlet to prevent an electric shock or fire. There is no guarantee of safety because you cannot make an earth connection in some multi type outlet and it is not a dedicated type outlet.

WARNING

- Use an outlet for EV charging with waterproofing processing installed if the installed position is outdoors or may get wet by rain etc.

3

CAUTION

- Use the outlet that is installed approximately 1 meter above the ground. If the outlet position is too low, the control box may touch the ground, which may lead to troubles such as submersion in water or getting trampled on.

NOTE

- The shape of the charging cable plug and outlet may differ from country to country as shown in the illustration.
- Use the following outlets.
- Check if the outlet on your vehicle corresponds with an outlet that is installed in the following places.
 - In your house etc.
 - In a parking lot or garage

Normal charging (charging method with rated AC 220-240V outlet)

3

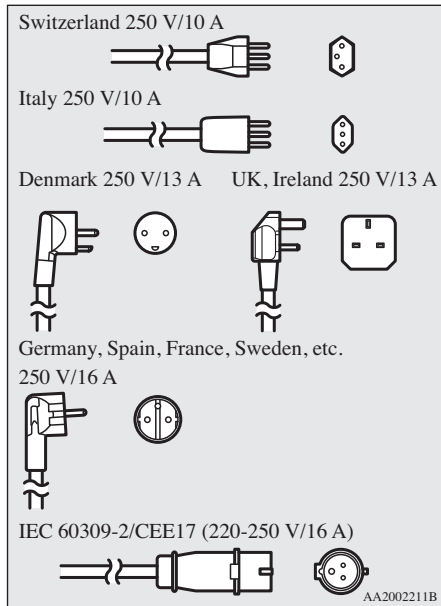

6. Remove the cap (E) on the normal charge connector (F) and make sure that there is no foreign matter such as dust at the end of the normal charge connector and the normal charge port.

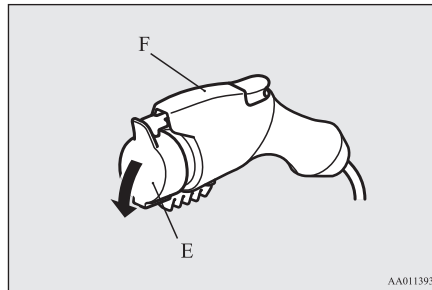

7. Connect the normal charge connector until a click sound is heard without pressing the release button (G).

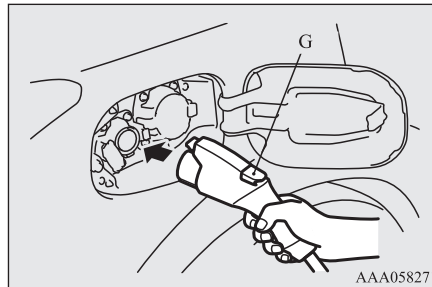

CAUTION

- Do not clasp the top of normal charge connector. It could cause injury to touch the protrusion on the charging lid.



NOTE

- If the operation mode of the power switch is ON with the EV charging cable remains connected to the normal charge port, the plug-in hybrid EV system does not turn ON.
- Do not connect or disconnect the normal charge connector repeatedly in a short period. Charging may not be started.
- If you want to turn the operation mode to "OFF" from the "ACC" or "ON" position in order to use an electrical device such as audio during charging, make sure that the select position is in "P", and press the power switch to turn "OFF" without depressing the brake pedal.

8. Make sure that the charging indicator (H) on the instrument cluster is illuminated.

Normal charging (charging method with rated AC 220-240V outlet)

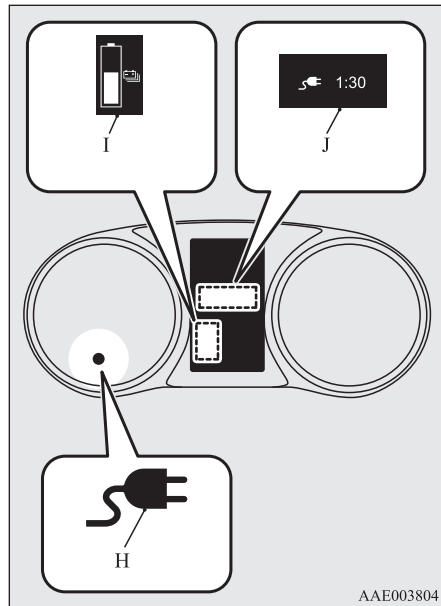

If the charging indicator is not illuminated, charging has not started. Make sure that the normal charge port and the plug are correctly connected, and perform charging from Step 5 again.

NOTE

- When the normal charge connector is connected to the charge port, the charging indicator will blink. When charging is started, the charging indicator illuminates and the charging port courtesy lamp blinks 3 times.
- If you want to confirm the drive battery level or the predicted charging time during charging, one of the doors is opened or the multi information display switch is operated, the drive battery level display (I) appears and the predicted charging time display (J) appears on the information screen in the multi information display. In addition, when the remaining time is less than 1 hour, the predicted charging time display (J) appears --:-- and does not indicate a malfunction. When an electrical component is used during charging, the charging time may become longer.

9. Charging is complete if the charging indicator goes off. Pull out the normal charge connector while pressing the release button (K).

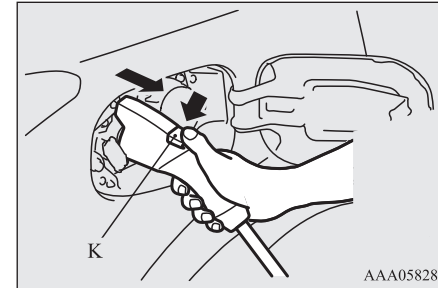

3

CAUTION

- Be sure to check the normal charge connector is removed from the normal charge port. The vehicle can be driven with the charge connector inserted when it is not locked completely which may result in a serious accident. Be sure the charge connector is removed completely from the vehicle after the charging is completed.

NOTE

- Charging can be stopped half way. In this case, also pull out the normal charge connector while pressing the release button. Pressing the manual stop button on the control box can also stop charging. Refer to "EV charging cable*" on page 3-07.

10. Close the inner lid and press the rear of the charging lid until it clicks to close it.

Normal charging (charging method with rated AC 220-240V outlet)

3

⚠ WARNING

- After charging, be sure to close the inner lid and charging lid completely. Be careful that water or dust does not enter in the normal charge port, inner lid and normal charge connector. Entry of water or dust could cause an electric leak, resulting in a fire or electric shock.

📖 NOTE

- Make sure that the inner lid is completely closed. If the charging lid is forcibly closed without completely closing inner lid, the hinge on the inner lid may be broken.
- While the charging lid is open, if the doors and tailgate are locked with the central door lock, the keyless entry system or the keyless operation system, the charging lid will lock when the charging lid is closed.
- When the operation mode is switched to ON while the charging lid is not completely closed, a warning may be displayed on the information screen in the multi information display. Refer to “Warning display list” on page 6-26.
- If the charging lid is closed while the driver’s door is locked, the charging lid will be locked.

11. Remove the charging cable plug from the outlet.

12. Install the cap on the normal charge connector.

⚠ WARNING

- After charging, be sure to disconnect the charge connector from the charge port. If the charge connector is only partially engaged and the connector latch is unlocked, you could put the operation mode of the power switch in ON and the vehicle could start moving. It could lead to an unexpected accident.

📖 NOTE

- Make sure that the charging lid is completely closed before using an automatic car wash. There is a possibility that the charging lid will be damaged if the lid is open.

If the charging lid cannot be unlocked

E08304400031

When the charging lid cannot be unlocked even if the driver’s door is unlocked, take the following measure to open the charging lid.

1. Press the tab (A) of the lid located on the right side of the luggage compartment to remove the lid.
2. Pull the rod (B) in the arrow direction to unlock the charging lid.

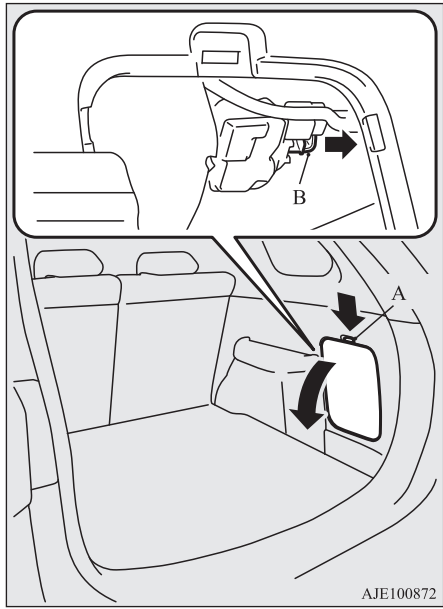

📖 NOTE

- After taking the emergency measure, please inspect at a MITSUBISHI MOTORS Authorized Service Point immediately.

Drive battery warming system*

E08304600020

You cannot start the Plug-in Hybrid EV System and drive when the ambient temperature is $-30\text{ }^{\circ}\text{C}$ or lower. (The warning display is displayed on the information screen in the multi-information display.) The drive battery warming system will automatically operate and the drive battery will be heated when you connect the normal charge connector to the normal charge port.

When the ambient temperature is higher than $-28\text{ }^{\circ}\text{C}$, you can start the Plug-in Hybrid EV System and drive. The drive battery warming system will automatically operate and the drive battery will be heated when all the following conditions are met.

- The normal charge connector is connected to the normal charge port at an ambient temperature under $-30\text{ }^{\circ}\text{C}$.
- The Plug-in Hybrid EV System is started at an ambient temperature between $-29\text{ }^{\circ}\text{C}$ and $-10\text{ }^{\circ}\text{C}$.

The drive battery warming system will automatically stop after the drive battery has been heated until suitable temperature.

NOTE

- When the ambient temperature is very cold, you cannot use the charging timer since the drive battery warming system is operating. And when the ambient temperature is $-30\text{ }^{\circ}\text{C}$ or lower, you cannot use the function of the remote climate control. When the ambient temperature is higher than $-29\text{ }^{\circ}\text{C}$ after operating the drive battery warming system, you can use the function of the remote climate control.

Quick charging (charging method with quick charger)

E08301401284

WARNING

- Be sure to use the quick charger applicable to CHAdeMO standard and certified by CHAdeMO association. Use of the other quick charger may cause the fire or malfunction.
- For operation of quick chargers, follow the manual of each quick charger.
- If you use electro-medical apparatus such as implantable cardiac pacemaker or implantable cardioverter-defibrillator, be careful the following precautions.
 - Please do not use a quick charger.
 - Keep away as much as possible from the place where the quick charger is stored. If you approach it carelessly, leave quickly without standing still.

WARNING

- Please ask someone to perform the quick charging if necessary.
- Before charging, make sure that there is no foreign matter such as dust at the quick charge port and the quick charge connector.
 - At this time, do not touch the quick charge port.
- When the quick charge connector is connected to the quick charge port, prevent foreign matter such as water or dust from entering in the port.
 - Connection with foreign matter such as water or dust may cause fire or an electric shock. Do not perform charging if there might be strong exposure to water at the connection.
- During charging, the cooling fans inside the bonnet room may automatically be operated even if the operation mode of the power switch is in OFF.
 - Keep your hands away from the cooling fan during charging.

3**NOTE**

- If the charge connector is not easily connected to the charge port due to foreign material entering, never force the connection. Doing so could damage the charging equipment or the vehicle. Contact a MITSUBISHI MOTORS Authorized Service Point.

Quick charging (charging method with quick charger)

NOTE

- The quick charger might be installed in the public parking space, some chargers are not suitable for this vehicle. Check the manual of each quick charger when charging.
- The charge connector and the EV charging cable stick out of the vehicle body while charging, so be careful that your body does not get stuck with them or they do not touch the next vehicle.
- The vehicle equipped with a quick charge port is compatible with most CHAdeMO*¹ connectors on charging stations.
- Make sure to lock the doors to prevent theft, etc. during charging.
- When using a quick charger, make sure that the time available is enough so that the quick charging can be finished in the time available.
If the power supply of the quick charger is shut off during quick charging, it could lead to a vehicle failure.

1. Firmly apply the parking brake, press the electrical parking switch to shift into the "P" (PARK) position and put the operation mode of the power switch in the "OFF" position.
2. Unlock the driver's door to unlock the charging lid.

*¹ CHAdeMO is a standard for quick charging of electric vehicle originally started in Japan, and the contents have also become an international standard.

3. Push the rear portion of the charging lid (A) until it clicks, and open the charging lid.

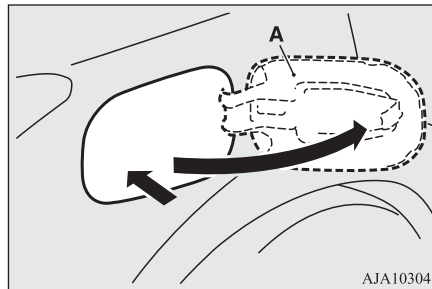

NOTE

- The charging lid is unlocked in conjunction with unlocking of the driver's door as the following condition.
 - The operation mode is put in "OFF" or "ACC".
 - The selector lever position is "P" (PARK).
- When the charging lid cannot be unlocked even if the driver's door is unlocked. Open the charging lid manually by using the release lever inside of the interior trim in the cargo room.
Refer to "If the charging lid cannot be unlocked" on page 3-16.

4. Press the tab (B) to open the inner lid (C).

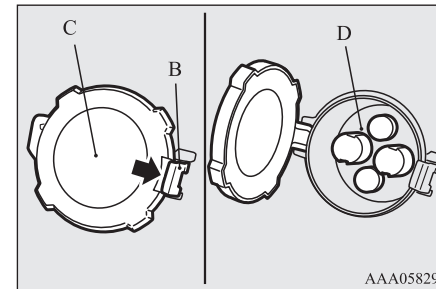

WARNING

- Do not leave the inner lid open for a long time.
It could cause an electric leak, a fire or an electric shock by water or dust entering into the quick charge port.
- Do not touch the metal terminal of the quick charge port (D) and the quick charge connector.
Doing so could cause an electric shock and/or malfunction.

Quick charging (charging method with quick charger)

CAUTION

- Be sure to insert the quick charge connector straight into the quick charge port right up to the base. Failure to do so may result in the drive battery not charging or could cause damage to the charging equipment.
- During quick charging, the quick charge connector cannot be removed because it is locked. Do not touch or remove the quick charge connector during charging. Doing so, the quick charge connector might be damaged. If you want to stop the quick charging on the way, stop the charging according to the procedures of a quick charger, and remove the quick charge connector after confirming the charging is stopped.

NOTE

- There is a hole on the charge port for water drainage. If this hole is blocked and water gets trapped in the charge port, do not charge. Contact a MITSUBISHI MOTORS Authorized Service Point.
- If the charge port is frozen, melt the ice using a hair drier. Forcing the charge connector to connect while frozen could result in malfunction.

5. Connect the quick charge connector in the quick charge port to begin charging. For connecting and disconnecting, follow the instruction manual for each quick charger.

6. Make sure that the charging indicator (E) on the instrument cluster is illuminated.

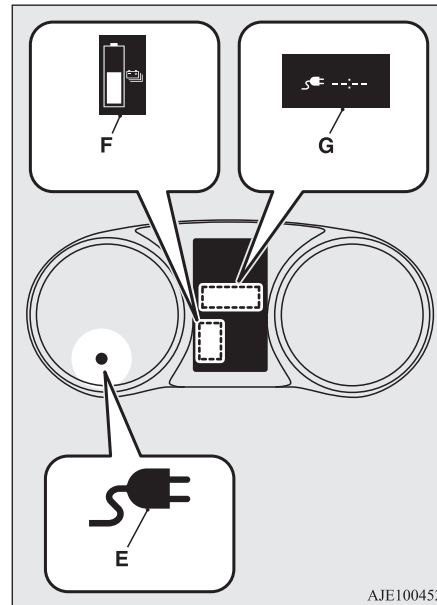

If the charging indicator is not illuminated, charging is not started. Follow the manual of each quick charger.

NOTE

- When the quick charge connector is connected to the charge port, the charging indicator is blinking. When charging is started, the charging indicator is illuminated.
- If you want to confirm the drive battery level during charging, open one of the doors or operate the multi information display switch, the drive battery level display (F) appears on the information screen in the multi information display. Although the predicted charging time display (G) appears, the charging time for the quick charging is approximately 30 minutes and displayed "--:--" in the screen and you cannot confirm the remaining charging time.
- Operation noise may be heard from the vehicle body during quick charging. This noise comes from the operation of the drive battery cooling system, and it is not a malfunction.
- Since the drive battery cooling system uses cool air of the air conditioning, the air conditioning is automatically operated. After quick charging, if the area under the vehicle is wet, transparent and loose, it is dehumidified water from the air conditioning and not a malfunction. When an electrical component is used during charging, the charging time may become longer.

7. Charging is complete when the charging indicator turns off.

3

MITSUBISHI Remote Control*

Disconnect the quick charge connector according to the manual of the quick charger.

3

CAUTION

- As the quick charge connector is heavier in comparison to the normal charge connector, allowing it to drop could cause damage to the vehicle or charge connector or personal injury. When removing the connector, be sure to pull it out straight and as carefully as possible.
- Do not leave the quick charge connector connected to the quick charge port after charging. Doing so, someone might stumble and it could cause an injury or the quick charging connection might be damaged by playing it.

NOTE

- Although it is possible to start the electric motor unit if quick charging has not finished normally, the charging indicator is continuously blinking. In such a situation, perform quick charging again and finish it normally or contact a MITSUBISHI MOTORS Authorized Service Point.

8. Close the inner lid and press the rear of the charging lid until it clicks to close it.

WARNING

- **After charging, be sure to close the inner lid and the quick charging lid completely. Be careful that water or dust does not enter in the quick charge port, inner lid and quick charge connector. Entry of water or dust could cause fire, electric shock or short circuit.**
- **After charging, be sure to disconnect the charge connector from the charge port. If the charge connector is only partially engaged and the connector latch is unlocked, you could put the operation mode of the power switch in ON and the vehicle could start moving. It could lead to an unexpected accident.**

NOTE

- If the operation mode of the power switch is put in ON with the quick charge connector connected to the quick charge port, the plug-in hybrid EV system cannot be started. Be sure to disconnect the quick charge connector before start.
- Charging may be completed before full charge. This is a control for efficient charge and not a malfunction. To achieve full charge, repeat charging from Step 5 again.

NOTE

- Make sure that the inner lid is completely closed. If the charging lid is forcibly closed without completely closing inner lid, the hinge on the inner lid may be broken.
- While the charging lid is open, if the doors and tailgate are locked with the central door lock, the keyless entry system or the keyless operation system, the charging lid will lock when the charging lid is closed.
- When the operation mode is switched to ON while the charging lid is not completely closed, a warning may be displayed on the information display of the multi information display. Refer to “Warning display list” on page 6-26.

MITSUBISHI Remote Control*

E08304200215

The MITSUBISHI Remote Control allows to operate the vehicle within the communication range of the wireless LAN device (which conforms to IEEE 802.11b and supports iOS or Android). The following operations are available.

NOTE

- The communication distance differs depending on the wireless LAN device, due to this the communication may go down.

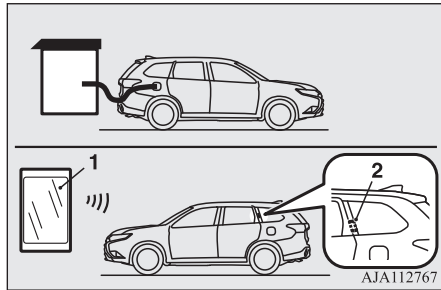

1- Wireless LAN device
2- Antenna

- **Charging timer**
If you specify the charge start and/or stop time with the normal charge cable connected, charging is started and/or stopped at that time.
- **Remote Climate Control**
By setting the remote climate control to operate at a predetermined time, cabin comfort can be improved or visibility can be ensured (defrosting/demisting) before getting in the vehicle.

- **Customize (function setting change)**
The function setting of the keyless operation system, outside rear-view mirror, operation mode of the power switch, air conditioning, lamps and windscreen wipers can be changed by MITSUBISHI Remote Control.

NOTE

- The electric heater is required to activate the reservation functions of heater, defroster and demister.
- In a vehicle equipped with the Smartphone Link Display Audio or the MITSUBISHI Multi-Communication System (MMCS), it is possible to change the setting by means of screen operations.
Refer to the separate owner's manual for details.
- If you want to quickly start normal charging even when the charging timer is already set, you can cancel the charging timer and start the normal charging by the following methods.
[How to temporarily cancel the charging timer]
You can temporarily cancel the charging timer by the following methods.
In addition, the predetermined charging timer settings will automatically return after the charging timer is turned on again or the operation mode of the power switch is put in ON.

NOTE

- **Keyless operation**
After connecting the normal charging cable and closing all the doors and the tailgate, you can cancel the charging timer by pressing the switch (A) of the keyless operation key twice within 2 seconds. When the charging timer is cancelled, the hazard warning lamps will blink four times.

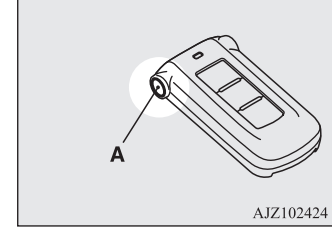

- **Wireless LAN device**
[How to cancel the charging timer]
The charging timer can be cancelled by the following methods.
 - Wireless LAN device
 - Smartphone Link Display Audio*
 - MITSUBISHI Multi-Communication System (MMCS)*
- When using the charging timer, use the EV charging cable. When using a home or public charging device (EVSE: Electric Vehicles Supply Equipment), the charging timer may not be started.

3

MITSUBISHI Remote Control*

3

Devices that support wireless LAN are required to communicate with the vehicle using the MITSUBISHI Remote Control. Also, an SSID* (A) and password (B) are required to connect a wireless LAN device to the vehicle. The SSID and password are described in the registration information card (C) that is attached to the key at the time of your purchase of the vehicle.

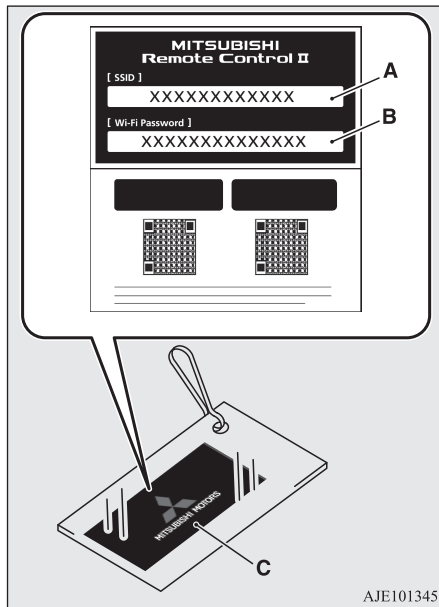

* The SSID is the identifier of an access point for IEEE 802.11 series wireless LAN. It is displayed on wireless LAN devices.

For the function and the operation method of the MITSUBISHI Remote Control, please visit the MITSUBISHI MOTORS Web site:

http://www.mitsubishi-motors.com/en/products/outlander_phev2/app/remote/

- If you need further information, please contact a MITSUBISHI MOTORS Authorized Service Point.

⚠ WARNING

- Do not use the MITSUBISHI Remote Control if children, persons in need of care, pets, etc. are in the vehicle. Even if the remote climate control is used, the cabin may become hot or cold due to some reasons such as automatic stop of the system. The cabin temperature may quickly rise in sunshine, which poses a risk of heat stroke and dehydration. In cold weather, on the other hand, the cabin temperature may quickly drop. Either of which could lead to death in the worst case. In addition, children can activate switches and controls, resulting in injury or a fatal accident.

⚠ WARNING

- The cooling fan in the engine compartment may operate automatically when charging or when operating air conditioner. Do not bring your hand close to the cooling fan during charging.

⚠ CAUTION

- Do not use a car cover except for the MITSUBISHI MOTORS GENUINE car cover, when using the charging timer or the remote climate control.

📖 NOTE

- Keep the following points in mind when using a wireless LAN device:
 - Communication speed and range vary depending on the wireless LAN devices and the surrounding conditions (radio environment, obstacles, parking area environment, etc.).
 - Due to the characteristics of radio waves, communication speed tends to decrease as the communication distance increases. Use your wireless LAN device at a short distance from the vehicle for better response.

NOTE

- When a microwave oven or ISM (industrial, scientific and medical) equipment is being used, the communication speed and range of wireless LAN devices may decrease. Use your wireless LAN device away from these appliances and equipment.
- If a wireless LAN device and Bluetooth (registered trademark of Bluetooth SIG, Inc.) are used simultaneously, the communication speed and range of each device may decrease. Use your wireless LAN device away from Bluetooth devices.
- Wireless LAN devices may not communicate with the vehicle, or may not operate normally or stably in the following environment or situations. Check that the device can communicate with your vehicle before use.
 - There is an obstruction such as a concrete or metal wall between the vehicle and wireless LAN device.
 - The vehicle is surrounded by tall vehicles in a parking lot.
 - There are facilities nearby that emit strong radio waves, such as a TV tower, transformer substation, broadcasting station or airport.
 - There is a communication device such as a mobile phone or radio, or an electric device such as a personal computer near the wireless LAN device.
 - The wireless LAN device is in contact with or covered by a metal object.

NOTE

- The battery of the wireless LAN device has run down.
- The MITSUBISHI Remote Control cannot be used under the following conditions:
 - The wireless LAN device is turned off.
 - The MITSUBISHI Remote Control application software is not installed.
 - The MITSUBISHI Remote Control application software is not running.
 - The wireless LAN device is not registered on the vehicle or it is not connected to the vehicle.
 - The wireless LAN device is out of the communication range.
 - The wireless LAN device is connected to other wireless LAN device.
 - The wireless LAN device has failed, or its battery has run out.
- Some charging facilities have a timer function that turns the power on or off at a specific time of the day. When charging at a facility with a timer function, make sure that the charging timer is set within the time period when the power in the charging facility is on.
- The auxiliary battery is automatically and periodically charged using electrical power stored in the drive battery. A buzzer sounds in the cabin while the auxiliary battery is being charged.
- While the remote climate control is operating or the charging, the cooling fan or air conditioner compressor may start operating and its sound may be heard. This is normal.

NOTE

- The remote climate control operates in its own mode based on the mode selected on the wireless LAN device, regardless of the switch setting of the vehicle's air conditioner.
- Air conditioning performance may deteriorate or the remaining charge in the drive battery may decrease under the following conditions:
 - In extremely hot weather.
 - In hot sunshine.
 - In extremely cold weather.
- If the remote climate control is started during charging, the time until full charge may extend or the charging rate may decrease.
- When the remaining quantity of the drive battery is decreased, the remote climate control does not operate or it may stop on the way.
- When the auxiliary battery is removed, the timer control of the MITSUBISHI Remote Control is reset and each function of the MITSUBISHI Remote Control cannot be used. Also the drive battery cannot be warmed up.
Communicate the wireless LAN device and your vehicle again.

How to use an electric device during charging

How to use an electric device during charging

E08304700021

3

If you turn the operation mode of the power switch to “ON” during normal charging, quick charging, V2H charging, V2H power supply, you can use the air conditioner, car navigation system, audio equipment and so on.

V2H (Vehicle to Home)

The vehicle power can be used as a household power supply source. Bidirectional charging of the vehicle or the home is carried out by using the quick charge connector of CHAdeMO standard which is the same as quick charging. “V2H charging” will charge the vehicle from the V2H main unit. “V2H power supply” supplies power from the vehicle to the home via the V2H main unit.

For details of V2H, please confirm with the PHEV to HOME sales catalogue or the instruction manual that is issued by the V2H maker or consult the V2H maker.

⚠ WARNING

- Do not get in the vehicle if the persons have electro-medical apparatus such as implantable cardiac pacemaker or implantable cardioverter-defibrillator, when using the air-conditioner during charging. It may affect the operation of electro-medical apparatus.
- Do not leave children and people who need nursing care and pets etc. inside the vehicle.
The inside of the vehicle may become hot or cold for reasons such as automatic system shutdown.
Also, when the outside air temperature is low, the temperature inside the vehicle may fall rapidly. In the worst case, there is a danger of death.
Also, since the wiper and the electric parking brake can be operated, an error in operation may lead to unexpected accidents.
- Please check the surroundings before using.
- Do not move the selector lever, the vehicle may move unintentionally.

📖 NOTE

- When using electrical devices during charging, the following cases may occur, since the charging to the drive battery is restricted.

📖 NOTE

- During normal charging:
The electricity consumption becomes larger than the charge amount, the drive battery may not be charged, and the remaining amount of the drive battery may decrease.
- During quick charging:
Charging time may be longer. Also, depending on the specifications of the quick charger, it may not be charged and the remaining amount of the drive battery may decrease.
- If you use an air conditioner etc. during charging, you may not be able to hear the radio due to strong electromagnetic waves or noise.

When using electrical devices

E08304800022

1. Start the normal charging or the quick charging.
Refer to “Normal charging (charging method with rated AC 220-240V outlet)” on page 3-10.
Refer to “Quick charging (charging method with quick charger)” on page 3-17.
2. Confirm that the charge lamp in the meter is illuminated.

NOTE

- If the charging lamp is not illuminated, the electrical devices will not be operated. Check that the charging is done correctly.

3. Put the operation mode of the power switch from OFF to ON.
Refer to “Changing the operation mode” on page 7-12.

NOTE

- Always put the operation mode of the power switch in ON after the charge lamp is illuminated. Charging may not start when you put the operation mode of the power switch in ON before the charge lamp is illuminated.
- When the operation mode of the power switch is ON, the door and tailgate cannot be locked by the keyless entry or the keyless operation function. When leaving the vehicle, put the operation mode in OFF and lock the vehicle.

4. Electric devices such as the air conditioner, car navigation system, audio equipment can be used.
Refer to “Warning display list” on page 6-26.

NOTE

- Put the operation mode in ON and use the electrical devices. If the operation mode of the power switch is ACC, the air conditioner cannot be used.
- For vehicles without the electric heater, the heating of the air conditioner cannot be used during charging.
- 220-240 V AC Power Supply (1500 W) cannot be used during charging.
- If the meter display screen is switched to the energy flow display, you can see the state of charging and discharging of the drive battery. Refer to “Energy flow indication during charging” on page 6-16.

When stopping the use of electrical devices

Put the operation mode of the power switch in OFF.
Refer to “Changing the operation mode” on page 7-12.

NOTE

- Charging continues even if the operation mode of the power switch is put in OFF. When the operation mode of the power switch is put to OFF, the air conditioner, car navigation system, audio equipment etc. are stopped.

Automatic OFF of the operation mode

E08305000021

In the following cases, the operation mode will be turned to OFF automatically.

3

- When the remaining amount of the drive battery decreases further after the air conditioner is stopped.
- When the outside air temperature is low and the following warning display appears.

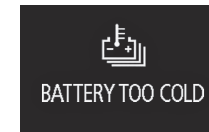

- When charging is completed.
- When the normal charge connector is disconnected.
- When the charging stop operation is performed by the quick charger.
- When the quick charging time has passed 60 minutes.
- When the stop condition (charging amount/charging time) on the quick charger is satisfied.
- When charging stops due to an electrical power outage.
- When charging stops due to a failure.
- When operating the selector lever to the “N” (NEUTRAL) position. (charging also stops)

How to use an electric device during charging

NOTE

- Even when the operation mode automatically puts off, air conditioners, car navigation systems, audio equipment, etc. will stop. Also, the vehicle status will be the same as putting the operation mode OFF (for example: the lights go off, the room lamp is illuminated or the electric mirrors are retracted).

3

Automatic stop of the air conditioner

E08305100022

In the following cases, the air conditioner automatically stops. When the air conditioner stops, the air conditioner control panel turns off.

- When the remaining amount of the drive battery becomes low and the following warning display appears.



Refer to “Warning display list” on page 6-26.

- When the temperature of the drive battery becomes extremely low and the following warning display appears.

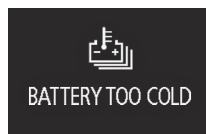

Refer to “Warning display list” on page 6-26.

NOTE

- To use the air conditioner again after the air conditioner automatically stops, press the power switch to turn the operation mode OFF with the following message appeared, then press the power switch again to turn ON the operation mode of the power switch so as to use the air conditioner.

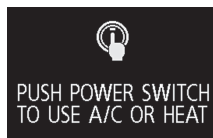

Refer to “Warning display list” on page 6-26.

Energy flow display during charging

E08305200023

It shows the flow of energy during charging.

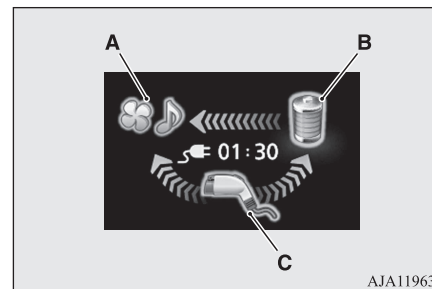

AJA119636

A: Various electrical devices

B: Drive battery

C: Charger

Blue arrow: Flow of electric energy

Display of energy flow (example)

When charging the drive battery

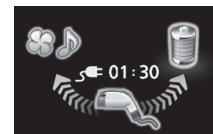

When discharging from the drive battery



V2H power supply



No energy flow



NOTE

- Energy flow display may change regardless of the operation of the air conditioner, car navigation system, audio equipment, etc.
- If you change the setting of the air conditioner, it may take time until the display of the energy flow stabilizes.

3

NOTE

- Even when you are not operating the air conditioner, car navigation system, audio equipment, etc., since the on-board computer consumes electricity, arrows may be displayed from the charger or the drive battery.

Charging troubleshooting guide

Charging troubleshooting guide

E08301501243

3

Symptom	Possible cause	Possible solution
Charging cannot be started.	The operation mode of the power switch is in the "ON" position.	Put the operation mode of the power switch in "OFF" before charging.
	The drive battery is already fully charged.	Charging cannot be performed if the drive battery is already fully charged. Charging automatically turns off if the drive battery is fully charged.
	The temperature of the drive battery is too high or too low to charge.	Confirm the drive battery temperature. Refer to "Cautions and actions to deal with intense heat" on page 2-10 and "Cautions and actions to deal with intense cold" on page 2-10.
	The auxiliary battery is discharged.	The drive battery cannot be charged if the vehicle electrical systems cannot be turned on. If the auxiliary battery is discharged, charge or emergency start the auxiliary battery. Refer to "Emergency starting" on page 9-02.
	The vehicle or the charging cable has a malfunction.	The vehicle or charging cable may have a malfunction. Confirm if the warning lamp on the meter is illuminated. Confirm if the indicator on the control box is indicating a malfunction. If a warning is displayed, stop charging and contact a MITSUBISHI MOTORS Authorized Service Point.
Normal charging cannot be started.	There is no electrical power coming from the outlet.	Confirm that there has not been a power failure. Make sure the breaker is on. If an outlet with a timer device installed is used, power will only be available at the time set by the timer. Confirm if the POWER indicator on the control box is illuminated.
	The charge connector is not connected correctly.	Confirm the charge connector is connected correctly.
	The charge connector was connected and disconnected repeatedly in a short time.	Disconnect the charge connector, wait for a while, then start charging procedure again from the beginning.

Charging troubleshooting guide

Symptom	Possible cause	Possible solution
	A charging cable for other vehicle is used.	Use the EV charging cable only for your vehicle.
	A normal charger which does not correspond to your vehicles is used.	Consult an administrator or a maker of the normal charger that it corresponds to your vehicle. Also perform normal charging according to the operating procedure indicated on the body of normal charger.
	The reservation of Charging timer is set up by MITSUBISHI Remote Control (if so equipped), Smartphone Link Display Audio (if so equipped) or by the MITSUBISHI Multi-Communication System (MMCS) (if so equipped).	The normal charging cannot be started when the charging cable is connected, if the charging timer is set. Cancel all the charging timer settings, if you want to start the normal charging immediately. Refer to “MITSUBISHI Remote Control” on page 3-20. For the MITSUBISHI Multi-Communication System (MMCS) refer to the separate owner’s manuals.
Normal charging is discontinued.	There is no power coming from the outlet.	There may have been a electrical power failure, or the breaker may have failed. Charging will resume when the power source is reset.
	The EV charging cable has been disconnected.	Check that the EV charging cable has not been disconnected.
	The button on the normal charge connector has been pressed.	If the charge connector button is pressed for a long period of time, charging will be stopped. Start the charging procedure again.
	The temperature of the drive battery is too high or too low to charge.	Confirm the drive battery temperature. Refer to “Cautions and actions to deal with intense heat” on page 2-10 and “Cautions and actions to deal with intense cold” on page 2-10.
	Charging is stopped by the normal charge timer.	Charging will stop depending on the timer function setting of the normal charge device. Try it again with cancelling the timer settings.

3

Charging troubleshooting guide

3

Symptom	Possible cause	Possible solution
	The Charging timer was set up by the MITSUBISHI Remote Control (if so equipped), Smartphone Link Display Audio (if so equipped) or the MITSUBISHI Multi-Communication System (MMCS) (if so equipped) after starting of normal charging.	Cancel all the charging timer settings. Charging is automatically restarted if you cancel the charging timer. Refer to “MITSUBISHI Remote Control” on page 3-20. For the MITSUBISHI Multi-Communication System (MMCS) refer to the separate owner’s manuals.
Quick charging cannot be started.	The charge connector is not connected correctly and/or not locked.	Check that the charge connector is connected correctly and that it is locked.
	The self-diagnostic function of the quick charge device returns a negative result.	There is a possibility that the vehicle has a malfunction. Stop charging and contact a MITSUBISHI MOTORS Authorized Service Point.
	The power switch of the quick charger is off.	Check the power switch of the quick charger. Consult an administrator or a maker of the quick charger.
Quick charge is discontinued.	Charging is stopped by the quick charge timer.	Charging will stop depending on the timer function setting of the quick charge device. If you need to charge the drive battery more, start the charging procedure again.
	Charging stops at 80 % capacity.	Charging is designed to stop when the drive battery capacity reaches 80 %. If you need to charge the drive battery more than 80 %, start the charging procedure again.
	The power supply for the quick charger is off.	Check whether the power supply for the quick charger is off. Consult an administrator or a maker of the quick charger.

Charging troubleshooting guide

Symptom	Possible cause	Possible solution
The charging indicator is continuously blinking even if the quick charge connector is not connected into the quick charge port when you start the plug-in hybrid EV system after quick charging.	Quick charging has not finished normally.	Perform quick charging again and finish it normally or contact a MITSUBISHI MOTORS Authorized Service Point.
Plug-in Hybrid EV System does not start after quick charging.	The vehicle has a malfunction.	There is a possibility that the vehicle has a malfunction. After turning the operation mode of the power switch to “ON” and putting the select position to “N”, ask the support of the fellow passenger or people nearby to move the vehicle by pushing it into safety. After moving, contact a MITSUBISHI MOTORS Authorized Service Point.

3

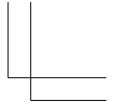
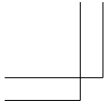

Handwriting practice lines consisting of 12 horizontal dashed lines.

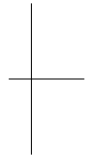
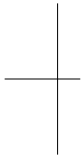

OGGE19E1

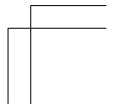
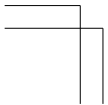

Locking and unlocking

Keys.....	4-02
Electronic immobilizer (Anti-theft starting system).....	4-03
Keyless entry system.....	4-03
Keyless operation system.....	4-06
Doors.....	4-14
Central door locks.....	4-16
Dead Lock System*.....	4-17
“Child-protection” rear doors.....	4-18
Tailgate*.....	4-19
Electric tailgate*.....	4-20
Inside tailgate release.....	4-27
Security alarm system*.....	4-27
Electric window control.....	4-34
Sunroof*.....	4-36

Keys

Keys

E00300104540

The key fits all locks.

without MITSUBISHI Remote Control

4

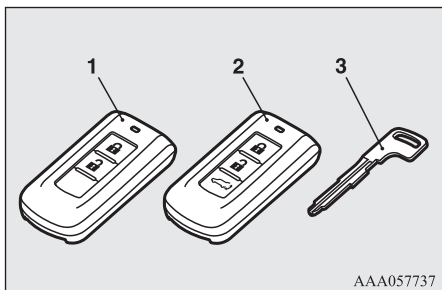

with MITSUBISHI Remote Control

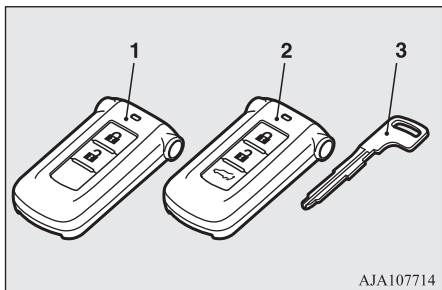

1- Keyless operation key

- 2- Keyless operation key (with electric tail-gate switch)
- 3- Emergency key

WARNING

- When taking a key on flights, do not press any switches on the key while on the plane. If a switch is pressed on the plane, the key emits electromagnetic waves, which could adversely affect the plane's flight operation. When carrying a key in a bag, be careful that no switches on the key can be easily pressed by mistake.

NOTE

- The key (except for the emergency key) is a precision electronic part with a built-in signal transmitter. Please observe the following in order to prevent a malfunction.
 - Do not leave in a place that is exposed to direct sunlight, for example on the dashboard.
 - Do not disassemble or modify.
 - Do not excessively bend the key or subject it to strong impacts.
 - Do not expose to water.
 - Keep away from magnetic key rings.
 - Keep away from audio systems, personal computers, TVs, and other equipment that generates a magnetic field.

NOTE

- Keep away from devices that emit strong electromagnetic waves, such as cellular phones, wireless devices and high frequency equipment (including medical devices).
- Do not clean with ultrasonic cleaners or similar equipment.
- Do not leave the key where it may be exposed to high temperature or high humidity.
- The plug-in hybrid EV system is designed so that it will not start if the ID code registered in the immobilizer computer and the key's ID code do not match. Refer to the "Electronic immobilizer" section for details and key usage.
- [For vehicles equipped with the security alarm system] Pay attention to the following if the security alarm is set to "Active". Refer to "Security alarm system" on page 4-27.
 - If the security alarm is in the system armed mode, the alarm will sound if the doors are opened after being unlocked with the key, the inside lock knob or the central door lock switch.
 - Even if the security alarm is set to "Active", the system preparation mode is not entered if the keyless entry system or the keyless operation function was not used to lock the vehicle.

Electronic immobilizer (Anti-theft starting system)

Key number tag

The key number is stamped on the tag as indicated in the illustration.

Make a record of the key number and store the key and key number tag in separate places, so that you can order a key from your MITSUBISHI MOTORS Authorized Service Point in the event the original keys are lost.

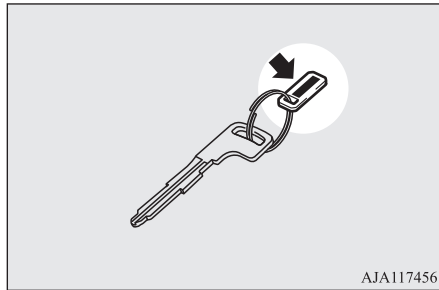

Electronic immobilizer (Anti-theft starting system)

E00300203791

The electronic immobilizer has been designed to significantly reduce the possibility of vehicle theft. The purpose of the system is to immobilize the vehicle if an invalid start is attempted. A valid start attempt can only be achieved by using a key “registered” to the immobilizer system.

CAUTION

- Do not modify or add parts to the immobilizer system. Doing so could cause the immobilizer to malfunction.

NOTE

- If the plug-in hybrid EV system does not start, we recommend you to contact your MITSUBISHI MOTORS Authorized Service Point.
- If you lose one of keyless operation keys, contact your MITSUBISHI MOTORS Authorized Service Point as soon as possible. To obtain a replacement or extra spare key, take your vehicle and all remaining keys to your MITSUBISHI MOTORS Authorized Service Point. All the keys have to be re-registered in the immobilizer computer unit. The immobilizer can register as follows.
 - Keyless operation key: up to 4 different keys

Keyless entry system

E00300304861

Press the remote control switch, and all doors and the tailgate will be locked or unlocked as desired. It is also possible to operate the outside rear-view mirrors.

4

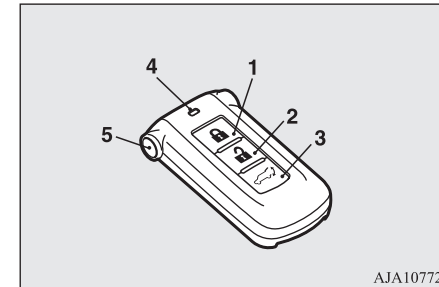

- 1- LOCK switch
- 2- UNLOCK switch
- 3- Electric tailgate switch*
- 4- Indication lamp
- 5- Charging timer cancel switch*

NOTE

- The charging lid is also locked/unlocked, when the driver's door is locked/unlocked.

OGGE19E1

Locking and unlocking 4-03

Keyless entry system

To lock

Press the LOCK switch (1). All the doors and the tailgate will be locked. The turn-signal lamps will blink once when the doors and the tailgate are locked.

4

To unlock

Press the UNLOCK switch (2). All the doors and the tailgate will be unlocked. If the doors and tailgate are unlocked when the front room lamp switch is in the "DOOR" position or the rear room lamp switch is in the middle (•) position, the room lamp will illuminate for approximately 15 seconds and the turn-signal lamps will blink twice.

The position and tail lamps can also be set to turn on for approximately 30 seconds. Refer to "Instruments and controls: Welcome light" on page 6-65.

NOTE

- For the operation of the Electric tailgate switch (3), refer to "Electric tailgate" on page 4-20.
- For the operation of the Charging timer cancel switch (5), refer to "MITSUBISHI Remote Control" on page 3-20.

NOTE

- The door and tailgate unlock function can be set so that only the driver's door unlocks when the UNLOCK switch (2) is pressed once.

If the door and tailgate unlock function is set to work as described above, all the doors and the tailgate unlock when the UNLOCK switch is pressed two times in succession. Refer to "Setting of door and tailgate unlock function" on page 4-05.

- If the UNLOCK switch (2) is pressed and no door or tailgate is opened within approximately 30 seconds, relocking will automatically occur.

- If either of the following problems occurs, the battery may be exhausted.

- The remote control switch is operated at the correct distance from the vehicle, but the doors and tailgate are not locked/unlocked in response.
- The indication lamp (4) is dim or does not come on.

For further information, please consult your MITSUBISHI MOTORS Authorized Service Point.

If you replace the battery yourself, refer to "Procedure for replacing the remote control switch battery" on page 4-05.

- It is possible to modify functions as follows: For further information, please contact your MITSUBISHI MOTORS Authorized Service Point.

On vehicles equipped with the Smartphone Link Display Audio or the MITSUBISHI

NOTE

Multi-Communication System (MMCS), screen operations can be used to make the adjustment. Refer to the separate owner's manual for details.

- The time for automatic relocking can be changed.
- The confirmation function (flashing of the turn-signal lamps) can be set to operate only when the doors and backdoor are locked or only when the doors and backdoor are unlocked.

- The confirmation function (this indicates locking or unlocking of the doors and tailgate with the blink of the turn-signal lamps) can be deactivated.

- The number of times the turn-signal lamps are flashed by the confirmation function can be changed.

- The outside rear-view mirrors automatically retract or extend when the doors and tailgate are locked or unlocked using the remote control switches of the keyless entry system. Refer to "Starting and driving: Outside rear-view mirrors" on page 7-09.

- The keyless entry system does not operate in the following conditions:

- The operation mode is not in OFF.
- The LOCK switch (1) is pressed while a door or the tailgate is open.

NOTE

- The remote control switch will operate within approximately 4 m from the vehicle. However, the operating range of the remote control switch may change if the vehicle is located near a power station, or radio/TV broadcasting station.
- If your remote control switch is lost or damaged, please contact your MITSUBISHI MOTORS Authorized Service Point for a replacement remote control switch.
- If you wish to add a remote control switch, we recommend you to contact your MITSUBISHI MOTORS Authorized Service Point.
The below remote control switches are available for your vehicle.
 - Keyless operation key: up to 4 remote control switches

Setting of door and tailgate unlock function

E00310301531

The door and tailgate unlock function can be set to the following two conditions. Each time the door and tailgate unlock function is set, a chime will sound to tell you the condition of the door and tailgate unlock function.

Number of chimes	Condition
One chime [Factory setting]	When the UNLOCK switch, driver's or front passenger's door lock/unlock switch, or tailgate open switch is pressed one time, all doors and the tailgate unlock.
Two chimes	When the UNLOCK switch or the driver's door lock/unlock switch is pressed one time, only the driver's door unlocks. When the UNLOCK switch or the driver's door lock/unlock switch is pressed two times in succession, all doors and the tailgate unlock.

1. Put the operation mode in OFF.
2. Place the combination headlamps and dipper switch in the "OFF" position, and leave the driver's door open.
3. Press the LOCK switch (1) for 4 to 10 seconds and press the UNLOCK switch (2) during this time.
4. Release in sequence the LOCK and UNLOCK switches within 10 seconds of pressing the LOCK switch in step 3.

OGGE19E1

NOTE

- The charging lid is also unlocked, when the driver's door is unlocked.
- On vehicles equipped with the Smartphone Link Display Audio or the MITSUBISHI Multi-Communication System (MMCS), screen operations can be used to make the adjustment. Refer to the separate owner's manual for details.

Procedure for replacing the remote control switch battery

E00309502022

Before replacing the battery, remove static electricity from your body by touching a metal grounded object.

WARNING

- **Danger of explosion if battery is incorrectly replaced. Replace only with the same battery or an equivalent type.**

CAUTION

- When the remote control switch case is opened, be careful to keep water, dust, etc. out. Also, do not touch the internal components.

Keyless operation system

NOTE

- You may purchase a replacement battery at an electric appliance store.
- A MITSUBISHI MOTORS Authorized Service Point can replace the battery for you if you prefer.

4

1. Remove the emergency key from the key.
Refer to “Emergency key” on page 4-14.
2. With the MITSUBISHI mark facing you, insert the cloth covered tip of a straight blade (or minus) screwdriver into the notch in the remote control switch case and use it to open the case.

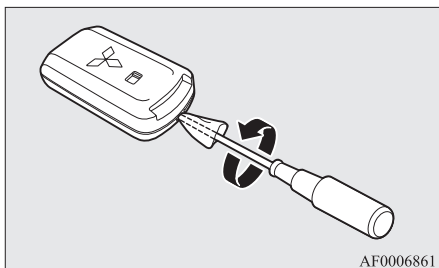

NOTE

- Be sure to perform the procedure with the MITSUBISHI mark facing you. If the MITSUBISHI mark is not facing you when you open the remote control switch case, the transmitter may come out.

3. Remove the old battery.
4. Install a new battery with the + side (A) up.

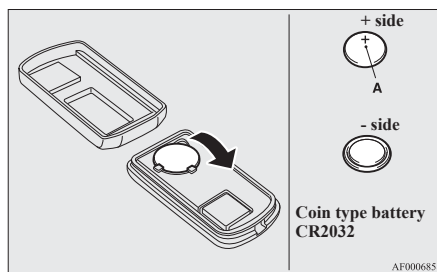

5. Close the case firmly.
6. Install the emergency key removed in step 1.
7. Check the keyless operation function to see that it works.

Keyless operation system

E00305602432

The keyless operation system allows you to lock and unlock the doors and tailgate and start the Plug-in Hybrid EV System simply by carrying the keyless operation key with you.

The keyless operation key can also be used as the keyless entry system remote control switch.

Refer to “Keyless entry system” on page 4-03.

The driver should always carry the keyless operation key. This key is necessary for locking and unlocking the doors and tailgate, starting the Plug-in Hybrid EV System and otherwise operating the vehicle, so before locking and leaving the vehicle, be sure to check that you have the keyless operation key.

WARNING

- People with implantable cardiac pacemakers or implantable cardiovascular-defibrillators should not go near the exterior transmitters (A) or the interior transmitters (B). The radio waves used by the keyless operation system could adversely affect implantable cardiac pacemakers or implantable cardiovascular-defibrillators.

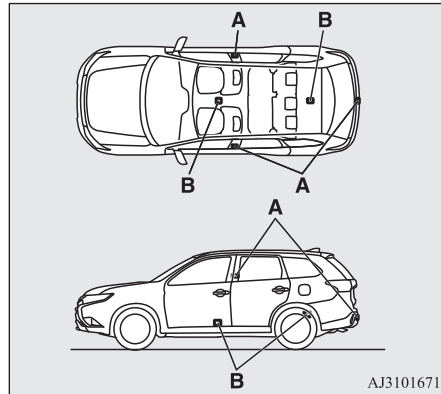

⚠ WARNING

- When using electro-medical devices other than implantable cardiac pacemakers or implantable cardiovascular-defibrillators, contact the electromedical device manufacturer ahead of time to determine the affects of radio waves on the devices. Electromedical device operations could be adversely effected by radio waves.

You can limit the possible operations of the keyless operation system in the following ways. (The keyless operation system can be used as a keyless entry system.) Please consult a MITSUBISHI MOTORS Authorized Service Point.

- You can limit operations to locking and unlocking the doors and tailgate.

- You can limit operations to starting the Plug-in Hybrid EV System.
- The keyless operation system can be disabled.

📖 NOTE

- The keyless operation key uses an ultra-weak electromagnetic wave. In the following cases, the keyless operation system may not operate properly or may be unstable.
 - When there is equipment nearby that emits strong radio waves, such as: a power station, a radio/TV broadcasting station or an airport.
 - The keyless operation system is carried together with a communications device such as a cellular phone or radio set, or with an electronic device such as a personal computer.
 - The keyless operation key is touching or covered by a metal object.
 - A keyless entry system is being used nearby.
 - When the keyless operation key battery is worn out.
 - When the keyless operation key is placed in an area with strong radio waves or noise.
- In such cases, use the emergency key.
Refer to “To operate without using the keyless operation function” on page 4-14.

📖 NOTE

- Because the keyless operation key receives signals in order to communicate with the transmitters in the vehicle, the battery continually wears down regardless of keyless operation key use. The battery life is 1 to 3 years, depending on usage conditions. When the battery wears out, replace the battery according to the description in this manual or have it replaced at your MITSUBISHI MOTORS Authorized Service Point. Refer to “Procedure for replacing the remote control switch battery” on page 4-05.
- Because the keyless operation key continually receives signals, strong radio wave reception could affect battery wear. Do not leave the key near a TV, personal computer, or other electronic device.

4

Operating range of the keyless operation system

E00305701830

If you are carrying the keyless operation key, enter the operating range of the keyless operation system, and press the driver's or front passenger's door lock/unlock switch, the tailgate LOCK switch or the tailgate open switch, the ID code for your key is verified.

Keyless operation system

You can lock and unlock the doors and tailgate and start the Plug-in Hybrid EV System only if the ID codes of your keyless operation key and the vehicle match.

4

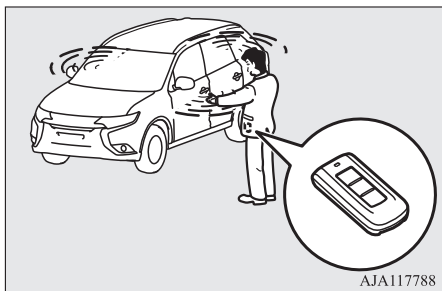

NOTE

- If the keyless operation key battery is wearing out or there are strong electromagnetic waves or noise present, the operating range may become smaller and operation may become unstable.

Operating range for locking and unlocking the doors and tailgate

E00306201858

The operating range is approximately 70 cm from the driver's door lock/unlock switch, front passenger's door lock/unlock switch, and tailgate lock/unlock switch.

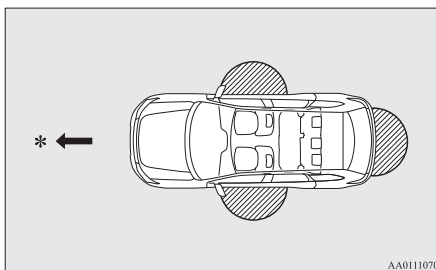

*: Forward direction

 Operating range

NOTE

- Locking and unlocking operate only when you press a door or tailgate switch that detects the keyless operation key.
- Operation may not be possible if you are too close to the front door, door window, or tailgate.

NOTE

- Even if the keyless operation key is within 70 cm of the driver's door lock/unlock switch, front passenger's door lock/unlock switch, or tailgate lock/unlock switch, if the key is near to the ground or high up, the system may not operate.
- If the keyless operation key is within the operating range, even someone not carrying the key can lock and unlock the doors and tailgate by pressing the driver's or front passenger's door lock/unlock switch, the tailgate lock switch or the tailgate open switch.

Operating range for starting the Plug-in Hybrid EV System and changing the operation mode

E00306301530

The operating range is the interior of the vehicle.

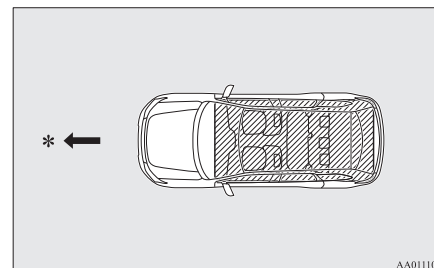

*: Forward direction

: Operating range

NOTE

- Even if it is within the operating range, if the keyless operation key is in a small item holder such as the glove box, on top of the instrument panel, door pocket or in the luggage area, it may be impossible to start the Plug-in Hybrid EV System.
- If a keyless operation key is too close to the door or door window, it may be possible to start the Plug-in Hybrid EV System or change the operation mode even when the key is outside the vehicles.

To operate using the keyless operation function

E00305802870

NOTE

- The charging lid is also locked/unlocked, when the driver's door is locked/unlocked.

Locking the doors and tailgate

When you are carrying the keyless operation key, if you press the driver's or front passenger's door lock/unlock switch (A), or the tailgate LOCK switch (B) within the operating range, the doors and the tailgate are locked.

The turn-signal lamps will blink once.

Also refer to "Locking and unlocking: Doors, Central door locks, Tailgate" on pages 4-14, 4-16 and 4-19.

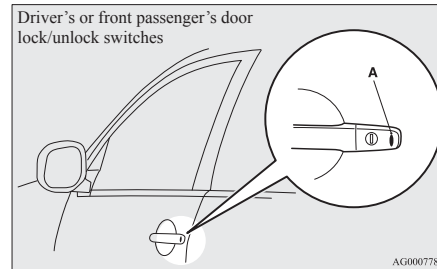

Tailgate switches

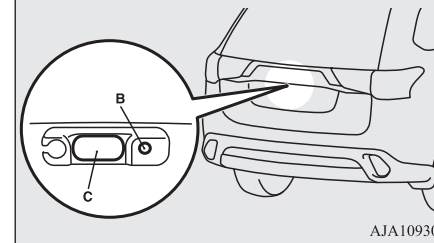

4

NOTE

- For vehicles equipped with the mirror retractor switch, the outside rear-view mirrors automatically retract when all the doors and tailgate are locked using the keyless operation function. Refer to "Starting and driving: Outside rear-view mirrors" on page 7-09.
- The keyless operation function does not operate under the following conditions:
 - The keyless operation key is inside the vehicle.
 - The operation mode of the power switch is not in OFF.
 - A door or the tailgate is open or ajar.
- The tailgate open switch (C) can be used to check that the vehicle is locked properly. Press the tailgate open switch within approximately 3 seconds of locking the vehicle. If you wait longer than 3 seconds and press the tailgate open switch, the doors and tailgate will be unlocked.

Keyless operation system

NOTE

- The time allowed for checking that the vehicle is locked can be adjusted. For further information, please contact your MITSUBISHI MOTORS Authorized Service Point.

On vehicles equipped with the Smartphone Link Display Audio or the MITSUBISHI Multi-Communication System (MMCS), screen operations can be used to make the adjustment. Refer to the separate owner's manual for details.

Unlocking the doors and tailgate

When you are carrying the keyless operation key, if you press the driver's or front passenger's door lock/unlock switch (A), or the tailgate open switch (B) within the operating range, all the doors and the tailgate are unlocked.

If the front room lamp switch is in the "DOOR" position or the rear room lamp switch is in the middle (●) position at this time, the room lamp will turn on for 15 seconds. The turn-signal lamps will blink twice.

If the driver's or front passenger's door lock/unlock switch is pressed and any of the doors or tailgate is not opened within approximately 30 seconds, relocking will automatically occur.

Also refer to "Locking and unlocking: Doors, Central door locks, Tailgate" on page 4-14, "Central door locks" on page 4-16 and "Tailgate*" on page 4-19.

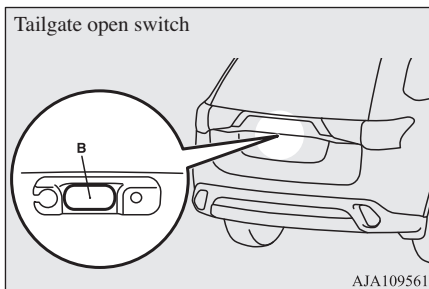
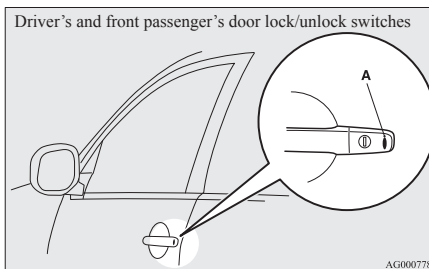

NOTE

- The outside rear-view mirrors automatically extend when all the doors and tailgate are unlocked using the keyless operation function.

Refer to "Starting and driving: Outside rear-view mirrors" on page 7-09.

- The keyless operation function can be set so that only the driver's door unlocks when the driver's door lock/unlock switch is pressed. If the keyless operation function is set to work as described above, all the doors and the tailgate unlock when the driver's door lock/unlock switch is pressed two times in succession.

Refer to "Setting of door and tailgate unlock function" on page 4-05.

- The keyless operation function does not operate when the operation mode of the power switch is not in OFF.
- In order to make it possible to check that the doors and tailgate are locked, you cannot unlock them by using the tailgate open switch for 3 seconds after locking them.
- The time allowed for checking that the vehicle is locked can be adjusted. For further information, please contact your MITSUBISHI MOTORS Authorized Service Point.

On vehicles equipped with the Smartphone Link Display Audio or the MITSUBISHI Multi-Communication System (MMCS), screen operations can be used to make the adjustment. Refer to the separate owner's manual for details.

NOTE

- The time between unlocking and automatic locking can be adjusted. Please consult a MITSUBISHI MOTORS Authorized Service Point.

On vehicles equipped with the Smartphone Link Display Audio or the MITSUBISHI Multi-Communication System (MMCS), screen operations can be used to make the adjustment. Refer to the separate owner's manual for details.

NOTE

- Functions can be modified as stated below. For further information, please contact your MITSUBISHI MOTORS Authorized Service Point.

On vehicles equipped with the Smartphone Link Display Audio or the MITSUBISHI Multi-Communication System (MMCS), screen operations can be used to make the adjustment. Refer to the separate owner's manual for details.

- Set the confirmation function (blinking of the turn-signal lamps) to operate only when the vehicle is locked or only when the vehicle is unlocked.
- Disable the operation confirmation function (blinking of the turn-signal lamps).
- Change the number of blinks for the operation confirmation function (blinks of the turn-signal lamps).

Operation confirmation when locking and unlocking

Operation can be confirmed as shown below. However, the room lamp will only illuminate if the front room lamp switch is in the "DOOR" position or the rear room lamp switch is in the middle (•) position.

- When locking: The turn-signal lamps will blink once.
- When unlocking: The room lamp illuminates for approximately 15 seconds, the turn-signal lamps blink twice.

Keyless operation system





Warning activation

E00305902464



In order to prevent vehicle theft or the accidental operation of the keyless operation system, the buzzer and the display on the information screen in the multi-information display are used to alert the driver.

If a warning is activated, always check the vehicle and the keyless operation key. The warning is also displayed if there is a fault in the keyless operation system.

4

Item	Display	Buzzer	Note (Solution)
Detection of failure		Inner buzzer sounds once.	There is a fault in the keyless operation system.
Fall of battery voltage		Inner buzzer sounds once.	The battery starts to run out, the warning is activated. (The warning is not activated if the battery is completely dead.)
Key not detected		Inner buzzer sounds once.	When the operation mode of the power switch is put in ACC or ON from OFF or when the Plug-in Hybrid EV System is started, the warning is activated, if any of the following conditions is occurred. <ul style="list-style-type: none"> ● Carrying another keyless operation key with a different code, or the keyless operation key could be outside the operating range. ● The battery of the keyless operation key is dead. ● Communication is blocked by electric wave environment.
Keyless operation key reminder		Inner buzzer sounds approximately 1 minute Outer buzzer sounds approximately 3 seconds intermittently	If the operation mode is in OFF and the driver's door is opened with the keyless operation key in the key slot, a warning is issued and the outer buzzer sounds for approximately 3 seconds and the inner buzzer sounds for approximately 1 minute to remind you to remove the key. If the key removed from key slot, the buzzer is stopped.



Keyless operation system

Item	Display	Buzzer	Note (Solution)
Keyless operation key take-out monitoring system		Inner buzzer sounds once. Outer buzzer sounds intermittently.	<ul style="list-style-type: none"> ● When the vehicle is parked with the operation mode in any mode other than OFF, if you close the door after opening any of the doors and taking the keyless operation key out of the vehicle, a warning is issued until the key is detected in the vehicle. ● If you take the keyless operation key out of the vehicle through a window without opening a door, the keyless operation key take-out monitoring system does not operate. ● It is possible to change the setting to make the keyless operation key take-out monitoring system operate if you take the keyless operation key out from the vehicle through a window without opening a door. For further information, please contact a MITSUBISHI MOTORS Authorized Service Point. ● Even if you have the keyless operation key within the operating range for starting the Plug-in Hybrid EV System, if the keyless operation key and vehicle ID codes cannot be matched, for example due to the ambient environment or electromagnetic conditions, the warning may be activated.
Key lock-in prevention system		Inner buzzer sounds once. Outer buzzer sounds approximately 3 seconds intermittently	<ul style="list-style-type: none"> ● When the operation mode is in OFF, if you close all the doors and the tailgate with the keyless operation key left in the vehicle and you try to lock the doors and tailgate by pressing the driver's or front passenger's door lock/unlock switch, or the tailgate LOCK switch, a warning is issued and you cannot lock the doors and tailgate. ● Make sure you have the keyless operation key with you before locking the doors. Even if you leave the keyless operation key inside the vehicle, it is possible that the doors will lock depending on the surrounding environment and wireless signal conditions.

4

Doors

4

Item	Display	Buzzer	Note (Solution)
Door ajar prevention system		Inner buzzer sounds once. Outer buzzer sounds approximately 3 seconds intermittently	When the operation mode in OFF, if you try to lock the doors and tailgate by pressing the driver's or front passenger's door lock/unlock switch, or the tailgate LOCK switch with one of the doors or the tailgate not completely closed, a warning is issued and you cannot lock the doors and tailgate.
Operation mode OFF reminder system		Inner buzzer sounds once. Outer buzzer sounds approximately 3 seconds intermittently	When the operation mode is in any mode other than OFF, if you try to lock the doors and tailgate by pressing the driver's or front passenger's door lock/unlock switch, or the tailgate LOCK switch, a warning is issued and you cannot lock the doors and tailgate.

To operate without using the keyless operation function

E0030600019

Emergency key

E00307201725

The emergency key is built into the keyless operation key. If the keyless operation function cannot be used, for example because the keyless operation key battery has worn out or the vehicle battery is flat, you can lock and unlock the driver's door with the emergency key.

To use the emergency key (A), unlock the lock knob (B) and remove it from the keyless operation key (C).

Refer to "Doors" on page 4-14.

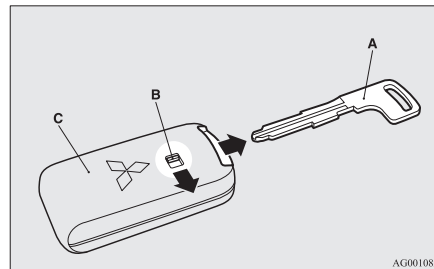

AG0010823

NOTE

- Only use the emergency key for emergencies. If the keyless operation key battery wears out, replace it as quickly as possible so that you can use the keyless operation key.
- After using the emergency key, always return it into the keyless operation key.

Doors

E00300403719

CAUTION

- Make sure the doors are closed: driving with doors not completely closed is dangerous.
- Never leave children in the vehicle unattended.

⚠ CAUTION

- Be careful not to lock the doors while the key is inside the vehicle.

📖 NOTE

- To prevent the key from being locked inside the vehicle, neither the lock knob on the driver's door nor the key can be used to lock the driver's door when it is open.

To lock or unlock with the key

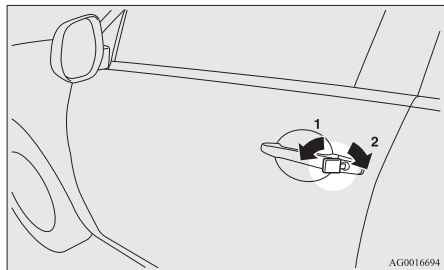

- 1- Lock
- 2- Unlock

📖 NOTE

- When locking or unlocking with the key, only the driver's door will be locked or unlocked.
To lock or unlock all doors, the charging lid and the tailgate, use the central door lock switch, the keyless entry system or the keyless operation function.
Refer to "Central door locks" on page 4-16, "Keyless entry system" on page 4-03, and "To operate using the keyless operation function" on page 4-09.
- The charging lid can be locked or unlocked at the same time when the driver's door is locked or unlocked using the key.
However, the charging lid cannot be unlocked while the operation mode of the power switch is in ON.

To lock or unlock from inside the vehicle

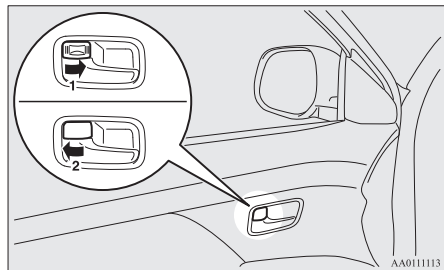

- 1- Lock

2- Unlock

Pull the inside door handle towards you to open the door.

📖 NOTE

- The driver's door can be opened without using the lock knob by pulling on the inside door handle.
- The charging lid can be locked or unlocked at the same time when the driver's door is locked or unlocked using the lock knob.
However, the charging lid cannot be unlocked while the operation mode of the power switch is in ON.

4

To lock without using the key

Front passenger's door, Rear door

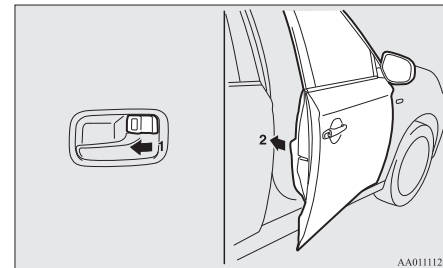

Central door locks

Set the inside lock knob (1) to the locked position, and close the door (2).

Central door locks

E00300803335

4

NOTE

- Repeated continuous operation between lock and unlock could activate the central door locking systems built-in protection circuit and prevent the system from operating. If this occurs, wait approximately 1 minute before operating the central door lock switch.
- When the driver's door is open, the central door lock switch cannot be used to lock it.
- The charging lid is also locked/unlocked, when the driver's door is locked/unlocked using the central door locks.

To lock and unlock the doors and tailgate

Using the central door lock switch

Using the central door lock switch on the driver's door locks or unlocks all doors and the tailgate.

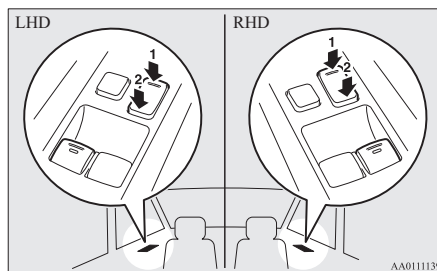

- 1- Lock
2- Unlock

NOTE

- The charging lid can be locked or unlocked at the same time when the driver's door is locked or unlocked using the central door lock switch. However, the charging lid cannot be unlocked while the operation mode of the power switch is in ON.

To unlock the doors and tailgate

E00311301336

You can select the function to unlock the doors and tailgate using the engine switch. This function is not activated when the vehicle is shipped from the factory. To activate or deactivate this function, please contact a MITSUBISHI MOTORS Authorized Service Point.

Using the power switch

All doors and the tailgate will unlock whenever the operation mode is put in OFF.

Dead Lock System*

E00305100198

The Dead Lock System helps prevent theft. When the keyless entry system or the keyless operation system has been used to lock all of the doors and the tailgate, the Dead Lock System makes it impossible to unlock the doors using the inside lock knobs.

CAUTION

- Do not set the Dead Lock System when someone is inside the vehicle. With the Dead Lock System set, it is not possible to unlock the doors using the inside lock knobs. If you erroneously set the Dead Lock System, unlock the doors using the UNLOCK switch on the remote control switch or using the keyless operation function.

Setting the system

E00305201330

1. Put the operation mode in OFF.
2. Get out of the vehicle. Close all of the doors and the tailgate.
3. Press the LOCK switch (A) on the remote control switch, the driver's or front passenger's door lock/unlock switch (C), or the tailgate LOCK switch (D) to lock all of the doors and the tailgate. The turn-signal lamps will blink once.

4. Press the switch again within 2 seconds. The turn-signal lamps will blink three times to show that the Dead Lock System has been set.

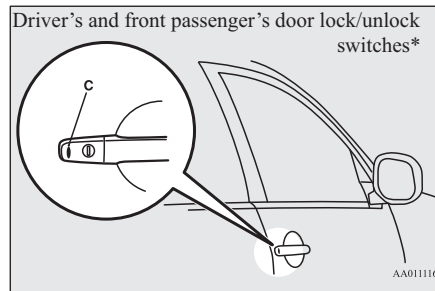
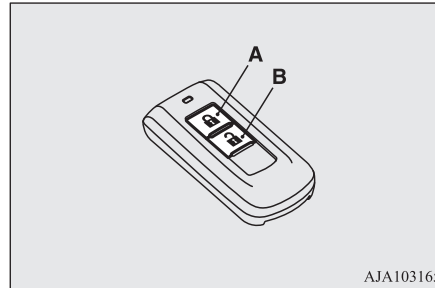

Dead Lock System*

Tailgate switches*

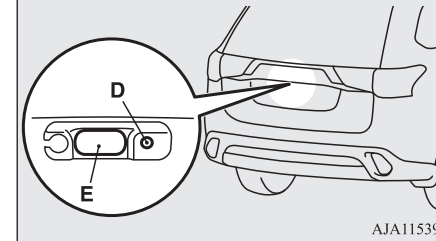

NOTE

- Pressing the LOCK switch (A) on the remote control switch once while the Dead Lock System is set causes the turn-signal lamps to blink three times, so it is possible to confirm that the Dead Lock System is set.

Canceling the system

E00305301432

When the following operation is performed, the doors and tailgate will unlock and the Dead Lock System will be simultaneously cancelled.

- The UNLOCK switch (B) on the remote control switch is pressed.
- The driver's or front passenger's door lock/unlock switch (C) or the tailgate open switch (E) is pressed while you are carrying the keyless operation key.

OGGE19E1

“Child-protection” rear doors

NOTE

- If neither a door nor the tailgate is opened within 30 seconds of unlocking (except using the tailgate open switch), the doors and tailgate are automatically relocked and the Dead Lock System is simultaneously set again.
- Even when it is not possible to use the keyless entry system or keyless operation function to unlock the doors, it is possible to use the key to unlock the driver's door. When the key is used to unlock the driver's door, the Dead Lock System is cancelled for only the driver's door. If you wish to subsequently unlock all other doors, turn the ignition switch to the “ON” or “ACC” position, or put the operation mode in on or ACC.
- It is possible to adjust the time between pressing the UNLOCK switch (B) on the remote control switch or the driver's or front passenger's door lock/unlock switch (C) and automatic locking. For details, please contact a MITSUBISHI MOTORS Authorized Service Point.
On vehicles equipped with the Smartphone Link Display Audio or the MITSUBISHI Multi-Communication System (MMCS), screen operations can be used to make the adjustment. Refer to the separate owner's manual for details.

4

NOTE

- It is possible to lock the doors and tailgate and set the Dead Lock System at the same time with a single push of the LOCK switch (A) on the remote control switch, the driver's or front passenger's door lock/unlock switch (C), or the tailgate lock switch (D). For details, please contact a MITSUBISHI MOTORS Authorized Service Point.

Testing the system

E00305400159

Open all of the door windows, then set the Dead Lock System.

(Refer to “Setting the system” on page 4-17.) After setting the Dead Lock System, reach into the vehicle through a window and confirm that you cannot unlock the doors using the lock knobs.

NOTE

- If you need advice on how to set the Dead Lock System, please contact a MITSUBISHI MOTORS Authorized Service Point.

“Child-protection” rear doors

E00300901042

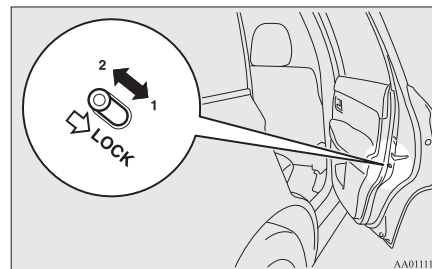

- 1- Lock
- 2- Unlock

Child protection helps prevent the rear doors from being opened accidentally from the inside.

If the lever is set to the locked position, the rear door cannot be opened using the inside handle, but only with the outside handle. If the lever is set to the “Unlock” position, the child protection mechanism does not function.

⚠ CAUTION

- When driving with a child in the rear seat, please use the child protection to prevent accidental door opening which may cause an accident.

Tailgate*

E00301402751

⚠ WARNING

- It is dangerous to drive with the tailgate open, since carbon monoxide (CO) gas can enter the cabin. You cannot see or smell CO. It can cause unconsciousness and even death.
- When opening and closing the tailgate, make sure that there are no people nearby and be careful not to hit your head or pinch your hands, neck, etc.
- When there is a build up of snow or ice, it should be removed before opening the tailgate. If you open the tailgate without removing it, there is a possibility that the tailgate may close suddenly due to the weight of that snow or ice.

⚠ WARNING

- When you open the tailgate make sure that the tailgate is opened fully and remains fully open. If you only open the tailgate halfway there is a risk that the tailgate may drop and slam shut. If you open the tailgate whilst your vehicle is parked on an incline it is more difficult to do so than on the flat and also it may drop and slam shut.

⚠ CAUTION

- To avoid damage to the tailgate, make sure the area above and behind the tailgate is clear before opening it.

To lock/unlock

The tailgate can be locked or unlocked by using the central door lock switch (driver side).

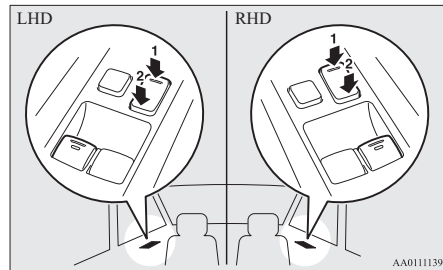

1- Lock

OGGE19E1

2- Unlock

📖 NOTE

- Repeated continuous operating between lock and unlock could cause the central door locks' built-in protection circuit to prevent the system from operating. If this occurs, wait approximately 1 minute before operating the central door lock switch.

4

To open

After unlocking the tailgate, push the tailgate open switch (A) and pull up the tailgate.

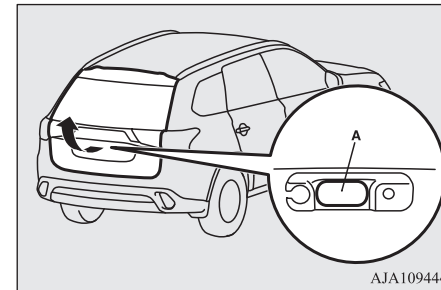

AJA109444

Electric tailgate*

NOTE

- The tailgate cannot be opened when the auxiliary battery is flat or disconnected. If you want to open the tailgate, it can be opened by using the inside tailgate release. Refer to “Inside tailgate release” on page 4-27.

4

To close

Pull the tailgate grip (B) downward as illustrated. Gently shut the tailgate from the outside so that it is completely closed. Always ensure the tailgate is securely closed.

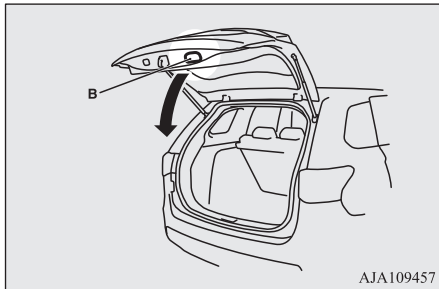

CAUTION

- When closing the tailgate, always ensure your or other person's fingers cannot be caught by the tailgate.

NOTE

- Gas struts (C) are installed to support the tailgate. To prevent damage or faulty operation.
 - Do not hold the gas struts when closing the tailgate.
 - Also, do not push or pull the gas struts.
 - Do not attach any plastic material, tape, etc., to the gas struts.
 - Do not tie string, etc., around the gas struts.
 - Do not hang any object on the gas struts.

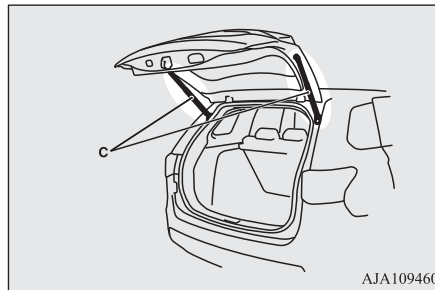

Electric tailgate*

E00312801035

Before operating the electric tailgate, unlock the tailgate by using the keyless entry system, keyless operation system, or the central door locks.

Refer to “Keyless entry system” on page 4-03, “Keyless operation system” on page 4-06, or “Central door locks” on page 4-16.

Operating the electric tailgate

E00312901124

WARNING

- The luggage area was not designed for people to ride in it. Do not let your children ride in or play in the luggage area. Riding or playing in the luggage area could result in a serious accident.
- Before driving, make sure the electric tailgate is securely closed. If you drive with the tailgate open, there is a danger of exhaust gas entering the vehicle and causing carbon monoxide poisoning.
- For safety's sake, the electric tailgate should be operated by adults and not children.
- When opening and closing the tailgate, make sure that there are no people nearby and be careful not to hit your head or pinch your hands, neck, etc. Make sure the electric tailgate is completely open before loading and unloading luggage.

⚠ CAUTION

- Do not stand behind the exhaust pipe when loading and unloading luggage. The heat from the exhaust could cause burns.
- To avoid damage to the tailgate, make sure the area above and behind the tailgate is clear before opening it.
- Before driving, make sure the electric tailgate is closed properly. If the tailgate opens when driving, luggage could fall onto the road and cause an accident.
- Do not install accessories other than MITSUBISHI MOTORS GENUINE parts on the electric tailgate. Some accessories could be too heavy, causing the drop prevention mechanism to operate.
- When closing the electric tailgate, make sure there is no foreign matter around the striker (A).
If foreign matter gets into the striker it could prevent the electric tailgate from closing normally.

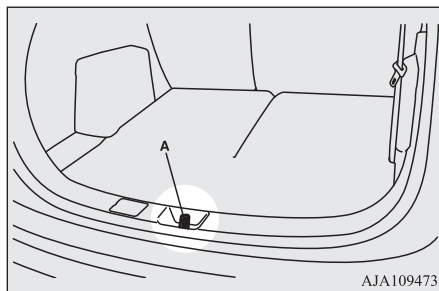

📖 NOTE

- When opening and closing the electric tailgate, do not place your hands near the arm (B).
- Gas struts (C) are installed in the locations shown below in order to support the electric tailgate.
- Make sure not to bump your head in the area near the arm of the electric tailgate when loading and unloading luggage.

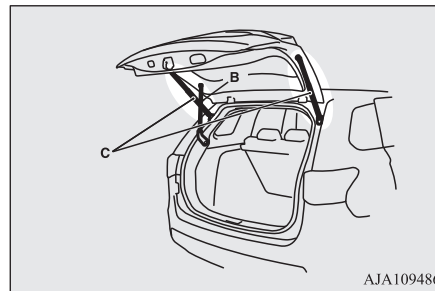

📖 NOTE

- Please observe the following in order to prevent damage or faulty operation.
 - Do not pull on the gas struts when closing the electric tailgate or otherwise push or pull them.
 - Do not attach any plastic material, tape, etc., to the gas struts.

📖 NOTE

- Do not tie string, etc., around the gas struts.
- Do not hang anything from the gas struts.

Automatic operation

E00313001177

The electric tailgate can be operated using the remote control switch on the keyless operation key, or the close switch on the tailgate when the electric tailgate power switch (A) is on.

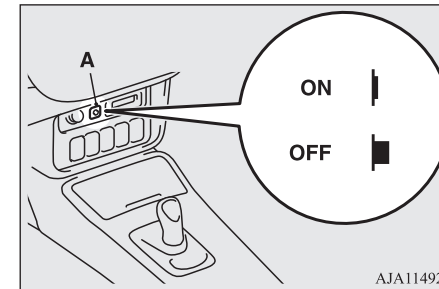

4

Electric tailgate*

4

WARNING

- **Turn off the electric tailgate power switch when not operating the electric tailgate. If the switch is left on, someone's hand or head could get caught if the electric tailgate switch or close switch is accidentally operated, or children play with the controls.**
- **If the electric tailgate power switch is turned off while the tailgate is operating, it will stop moving and switch to manual operation. At this time, the electric tailgate could open or close suddenly, depending on its position.**

CAUTION

- Do not apply excessive force on the electric tailgate when opening or closing it. Doing so could cause a breakdown.
- Do not start the Plug-in Hybrid EV System while the tailgate is operating. The sudden operation prevention mechanism could operate, making the electric tailgate stop intermittently while it moves.

NOTE

- The electric tailgate cannot be opened when the auxiliary battery is flat or disconnected. If you want to open the electric tailgate, it can be opened by using the inside tailgate release. Refer to "Inside tailgate release" on page 4-27.
- If the keyless entry system or close switch is operated when the electric tailgate power switch is off, the warning buzzer sounds four times to notify the driver that the electric tailgate cannot be operated.
- The electric tailgate does not operate normally under the following conditions:
 - When parked on an incline
 - In strong winds
 - When the electric tailgate is covered with snow
- Repeated continuous operation between opening and closing the electric tailgate will activate the built-in protection circuit and switch the tailgate to manual operation.
- If the electric tailgate handle is operated while the tailgate is operating or immediately after it is closed, the tailgate will move in the direction opposite to the one in which it was operating.
- If the battery or fuse is replaced while the electric tailgate is open, it cannot be closed automatically. In this case close the electric tailgate manually.

Operating conditions

E00313101224

The electric tailgate can be opened automatically when all of the following conditions are met.

<Using the keyless operation key>

- The operation mode is in OFF.
- The electric tailgate is completely closed.
- The electric tailgate is unlocked.

<Using the driver's side electric tailgate switch>

- The operation mode is in ON with the electrical parking switch is pressed.
- The electric tailgate is completely closed.
- The electric tailgate is unlocked.

The electric tailgate can be closed automatically when all of the following conditions are met.

<Using the keyless operation key>

- The operation mode is in OFF.
- The electric tailgate is completely open.
- People, luggage, etc., are not touching the sensors.

<Using the driver's side electric tailgate switch or close switch>

- The operation mode is in ON with the electrical parking switch is pressed.

- The electric tailgate is completely open.
- People, luggage, etc., are not touching the sensors.

- While closed: The warning buzzer sounds and the tailgate completely opens.
- While open: The warning buzzer sounds and the tailgate completely closes.

- While open: The warning buzzer sounds and the tailgate completely closes.

Operating the electric tailgate using the keyless operation key or the driver's side electric tailgate switch

After unlocking the doors and the electric tailgate, the electric tailgate can be operated by pressing the switch (A) of the keyless operation key or the driver's side electric tailgate switch (B).

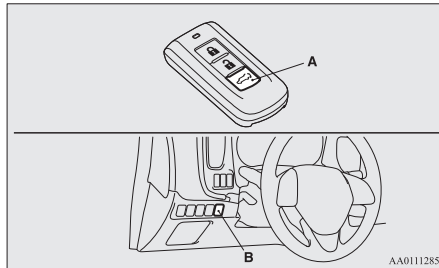

<Using the keyless operation key>

If the electric tailgate switch is pressed twice in a row, the electric tailgate operates after the warning buzzer sounds and the hazard warning flasher blinks.

The electric tailgate operates as follows:

If the electric tailgate switch is pressed once while the tailgate is operating, the warning buzzer sounds and it moves in the direction opposite to the one in which it was operating.

NOTE

- If the electric tailgate switch is pressed three or more times in a row, the tailgate may not operate normally.
If this occurs, wait a short time before again pressing the electric tailgate switch twice.

<Using the driver's side electric tailgate switch>

If the driver's side electric tailgate switch is pressed for more than approximately 1 second, the electric tailgate operates after the buzzer sounds and the hazard warning flasher blinks.

The electric tailgate operates as follows.

- While closed: The warning buzzer sounds and the tailgate completely opens.

If the driver's side electric tailgate switch is pressed once while the tailgate is operating, the warning buzzer sounds and it moves in the direction opposite to the one in which it was operating.

WARNING

- When operating the electric tailgate, ensure the safety of the surrounding area, make sure there is sufficient space behind and above the vehicle, and be careful not to bump your head or catch your hands or fingers.

Electric tailgate*

Opening the electric tailgate using the open switch

The electric tailgate can be opened by pressing the open switch (C).

4

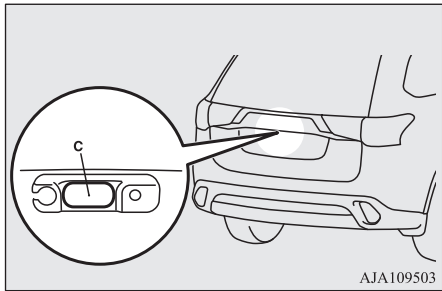

If the open switch is pressed with the tailgate and all doors are unlocked, the electric tailgate opens after the warning buzzer sounds. When the tailgate and all doors are locked, the warning buzzer will not sound.

NOTE

- When the keyless operation key is within the operation range, the electric tailgate can be opened by pressing the open switch even if the tailgate is locked.

Closing the electric tailgate using the close switch

The electric tailgate can be closed by pressing the close switch (D) on the inside of the electric tailgate.

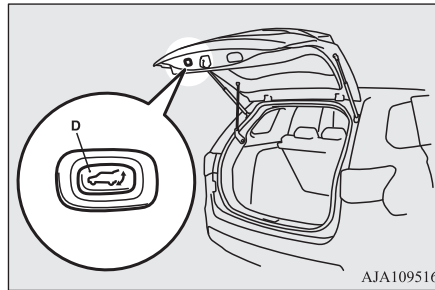

If the close switch on the inside of the electric tailgate is pressed, the electric tailgate closes after the warning buzzer sounds and the hazard warning flasher blinks. If the close switch is pressed once while the tailgate is closing, the warning buzzer sounds and the electric tailgate opens.

NOTE

- If the close switch is again pressed once while the electric tailgate is operating in the opening direction, the warning buzzer sounds once and the electric tailgate closes.

Safety mechanism

E00313201036

The safety mechanism is activated if the electric tailgate should trap a person or an object during automatic operation, or if the sensors (A) on either side of the electric tailgate are hit. The warning buzzer sounds once for safety and the electric tailgate automatically moves in the direction opposite to the one in which it was operating.

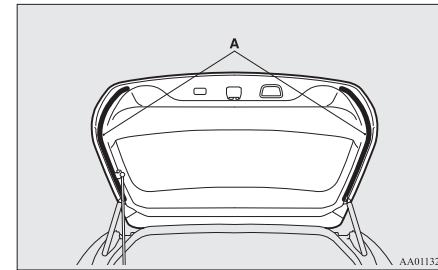

CAUTION

- The safety mechanism will sometimes not operate depending on the condition of the trapped object or how it is trapped. Therefore, be especially careful not to trap a hand, part of your body or an object at this time.

⚠ CAUTION

- The safety mechanism is cancelled just before the electric tailgate is fully closed to allow it to close completely. Therefore be especially careful not to trap a hand or finger at this time.
- The safety mechanism is deactivated when the electric tailgate is closed manually. Therefore be especially careful not to trap a hand or finger at this time.
- If the safety mechanism is repeatedly operated, the tailgate could be switched to manual operation. Be careful at this time, as the electric tailgate could open or close suddenly, depending on its position. Once the electric tailgate is completely open or closed, normal automatic operation is again possible.

📖 NOTE

- If the environment or usage conditions subject the sensors to the same kind of force as that of trapping a person or object, the safety mechanism could be activated.
- Do not damage the sensors when loading or unloading luggage, or when cleaning the rear window. Doing so could prevent the tailgate from closing automatically.

Drop prevention mechanism

After the electric tailgate is opened automatically, if it is detected that the tailgate is dropping due to factors such as accumulated snow, the electric tailgate is closed automatically.

A warning buzzer sounds continuously while the drop prevention mechanism operates.

📖 NOTE

- If snow has accumulated on the electric tailgate, remove it before operation.
- Do not install accessories other than MITSUBISHI MOTORS GENUINE parts on the electric tailgate. Some accessories could be too heavy, causing the drop prevention mechanism to operate.
- The drop prevention mechanism could be activated if manual operation is attempted immediately after the electric tailgate is completely opened automatically.

Sudden operation prevention mechanism

If the Plug-in Hybrid EV System is started while the electric tailgate is operating automatically, it may switch to manual operation due to insufficient auxiliary battery voltage, making the electric tailgate stop intermittently while it moves. This is to stop the electric tailgate from operating suddenly. When the tailgate is completely closed or opened, automatic operation is again possible after approximately 10 seconds.

⚠ CAUTION

- The safety mechanism is deactivated while the sudden operation prevention mechanism is operating. Therefore be especially careful not to trap a hand or finger at this time.

Manual operation

E00313401083

If the electric tailgate power switch is off, the electric tailgate can be operated by manual operation.

Electric tailgate*

After unlocking the electric tailgate, push the tailgate open switch (A) and pull up the tailgate.

4

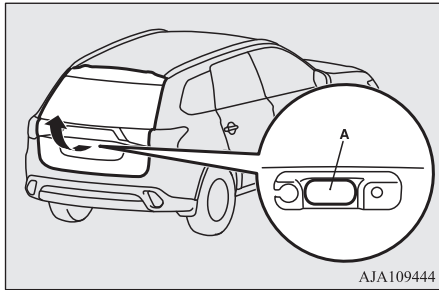

CAUTION

- Make sure there is no one around the electric tailgate when opening it.

NOTE

- If it does not open immediately after pushing the tailgate open switch, the electric tailgate cannot be lifted.
If this occurs, push the tailgate open switch again and pull up the electric tailgate.
- The electric tailgate cannot be opened when the auxiliary battery is flat or disconnected.

To close the tailgate, pull the tailgate grip (B) downward and release it before the tailgate is completely closed, and then gently slam the electric tailgate from the outside.

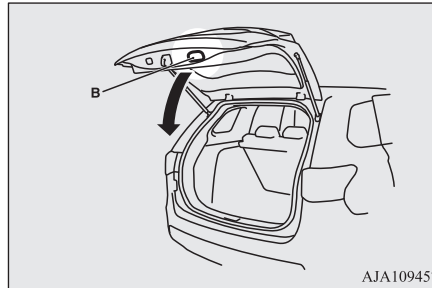

CAUTION

- Do not fully close the electric tailgate with your hand still on the tailgate grip. Doing so could trap and injure your hand or arm.
- The safety mechanism is deactivated when the electric tailgate is closed manually. Therefore be especially careful not to trap a hand or finger at this time.

Tailgate easy closer

The tailgate easy closer is a mechanism for assisting the closing of the electric tailgate. If the electric tailgate is closed to a position where it is detected as being ajar, it closes automatically.

E0031330069

OGGE19E1

WARNING

- Be careful not to catch your hands or fingers when the electric tailgate closes automatically from the door ajar position. If you think your hands or fingers could be caught during the operation of the tailgate easy closer, pull the handle of the electric tailgate. The electric tailgate will return to the door ajar position.

CAUTION

- Do not touch the latch (A) on the inside of the electric tailgate. The tailgate easy closer could operate and catch your fingers.

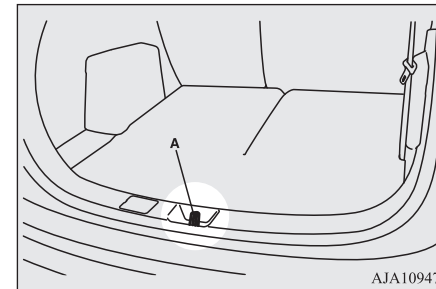

NOTE

- The tailgate easy closer operates even when the electric tailgate power switch is OFF.

NOTE

- Repeated continuous operation of the handle could activate the protection circuit and temporarily prevent the tailgate easy closer from operating.
If this occurs, wait about 1 minute before operating the tailgate easy closer again.

Inside tailgate release

E00303401370

The inside tailgate release is designed to provide a way to open the tailgate in the case of a discharged auxiliary battery.

The tailgate release (see illustration) is mounted on the tailgate.

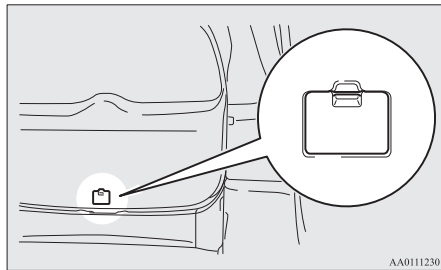

AA0111230

You and your family should familiarise yourselves with the location and operation of the tailgate release.

To open

1. Open the lid (A) inside of the tailgate.

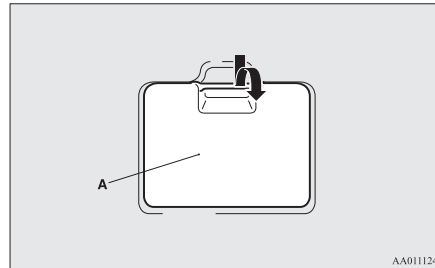

AA0111243

2. Move the lever (B) to open the tailgate.

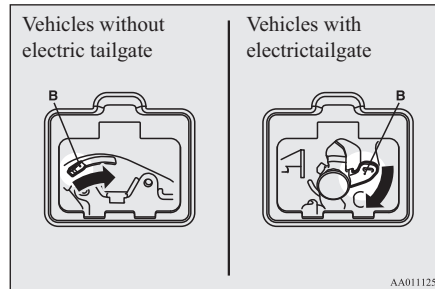

AA0111256

3. Push out on the tailgate to open it.

CAUTION

- Always keep the release lever lid on the tailgate closed when driving so that your luggage cannot accidentally bump against the lever and open the tailgate.

4

Security alarm system*

E00301502172

The security alarm system is for alerting the surrounding area of suspicious behaviour to prevent unlawful entry into the vehicle by operating an alarm if a door, the tailgate or the bonnet is opened when the vehicle has not been unlocked using the keyless entry system or the keyless operation function.

Also, for vehicles equipped with the interior alarm sensor, the alarm will be activated if any of the following occurs:

- attempt to an unlawful moving of the vehicle (the vehicle inclination detection function)
- detection of a motion in the vehicle (the interior intrusion detection function)
- disconnection of the battery terminal

The security alarm system is set to “active”. When making changes to the settings, please follow the procedure listed in the section titled “Changing the security alarm settings” on page 4-30.

Security alarm system*

On vehicles equipped with the Smartphone Link Display Audio or the MITSUBISHI Multi-Communication System (MMCS), screen operations can be used to make the adjustment. Refer to the separate owner's manual for details.

4

CAUTION

- Do not modify or add parts to the security alarm system. Doing so could cause the security alarm to malfunction.

NOTE

- The alarm system will not be activated if the doors and the tailgate have been locked using a key, the inside lock knob or the central door lock switch (instead of the keyless entry system or the keyless operation function).

NOTE

- For vehicles equipped with the interior alarm sensor, if the turn-signal lamps do not blink after the locking and unlocking operation using the keyless entry system or the keyless operation function, the security alarm system may be malfunctioning.

Have the vehicle inspected at a MITSUBISHI MOTORS Authorized Service Point.

If the confirmation function (blinking of the turn-signal lamps by locking and unlocking the doors and the tailgate) is deactivated, the turn-signal lamps do not blink after the locking and unlocking operation.

For information on the confirmation function, refer to “Keyless entry system” on page 4-03 and “To operate using the keyless operation function” on page 4-09.

- For vehicles equipped with the interior alarm sensor, the security alarm system could be activated in the following situations.
 - Using a car wash
 - Taking the vehicle on a ferry
 - Parking in an automated car park
 - Leaving someone or a pet in the vehicle
 - Leaving a window or the sunroof open
 - Leaving an unstable object such as a stuffed toy or accessory in the vehicle
 - Suffering a continuous impact or vibration by hail, thunder, etc.

NOTE

- Air flows by the Remote Climate Control. According to the situations, please deactivate the vehicle inclination detection function and the interior intrusion detection function.

Refer to “To deactivate the vehicle inclination detection function and the interior intrusion detection function” on page 4-32.

- For vehicles equipped with the interior alarm sensor, the sensitivity of the interior intrusion detection function can be adjusted. For details, please contact a MITSUBISHI MOTORS Authorized Service Point.

The security alarm has four modes:

System preparation mode (approximately 20 seconds)

(The buzzer sounds intermittently and the security indicator (A) blinks.)

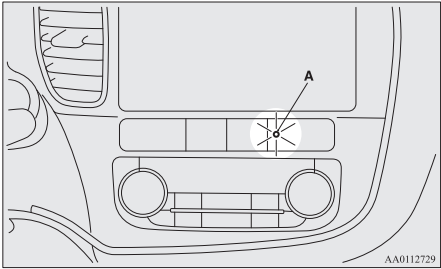

The system preparation time extends from the point at which all of the doors and the tailgate are locked by pressing the LOCK switch on the remote control switch or the keyless operation function to the point at which the system armed mode goes into effect.

During this time, it is possible to temporarily open a door or the tailgate without using the keyless entry system or the keyless operation function and without causing the alarm to sound (for example, when you forget something inside the vehicle or realize that a window is open).

System armed mode

(The buzzer stops and the security indicator continues to blink with the indicator's reduced lit-up duration time.)

Once the system preparation mode has ended, the system armed mode starts.

If an unlawful opening of any of the doors, tailgate or bonnet is detected during the system armed mode, the alarm will be activated to warn people around the vehicle of an abnormal condition.

Also, for vehicles equipped with the interior alarm sensor, if unlawful moving of the vehicle is attempted or a vehicle intrusion is detected, the alarm will be activated.

Alarm activation

Inside alarm (approximately 10 seconds):
The buzzer sounds, warning those inside the vehicle of an abnormal condition.
(except for vehicles equipped with the interior alarm sensor)

Outside alarm (approximately 30 seconds):

The turn-signal lamps blink and the horn (the siren for vehicles equipped with the interior alarm sensor) sounds, warning people around the vehicle of an abnormal condition.

Refer to "Alarm activation" on page 4-33.

NOTE

- The alarm will resume if unlawful actions are taken again, even if the alarm has stopped.

System cancellation

It is possible to cancel the system activation during the system preparation mode or the system armed mode.

In addition, it is possible to cancel the alarm once it has been activated.

Refer to "Cancelling the system" on page 4-32, "Cancelling the alarm" on page 4-34.

NOTE

- When lending the vehicle to another person or allowing the vehicle to be driven by someone who is unfamiliar with the security alarm system, be sure to give the person a proper explanation of the security alarm system.
If a person who is unfamiliar with the security alarm system accidentally unlocked the vehicle, causing the alarm to sound, the alarm would be a nuisance to people nearby.

Security alarm system*

Changing the security alarm settings

E00301601365

It is possible to set the security alarm to the “active” mode or “inactive” mode.

4

Follow the procedure below.

1. Put the operation mode in OFF.
2. Place the lamp switch in the “OFF” position, and leave the driver’s door open.

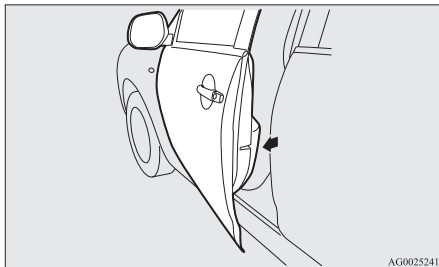
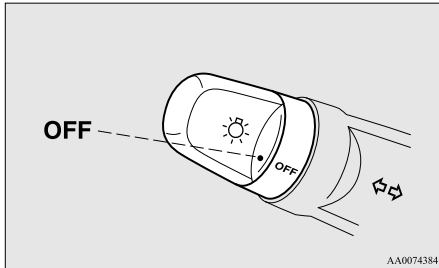

3. Pull the windscreen wiper and washer switch towards you and hold it there. (Since the operation mode in OFF, washer fluid will not be sprayed.)

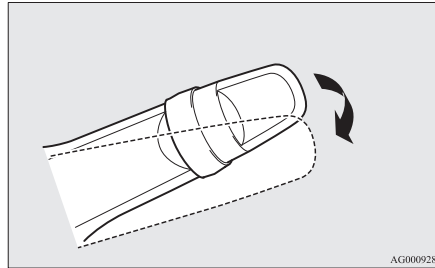

4. After approximately 10 seconds, the buzzer will make a sound. Keep the windscreen wiper and washer switch pulled towards you. (If the windscreen wiper and washer switch was released, the setting change mode would be cancelled. To start over, perform the procedure again from step 3.)
5. When the buzzer stops, with the windscreen wiper and washer switch still pulled towards you, press the UNLOCK switch (A) on the remote control switch to select the security alarm settings mode.

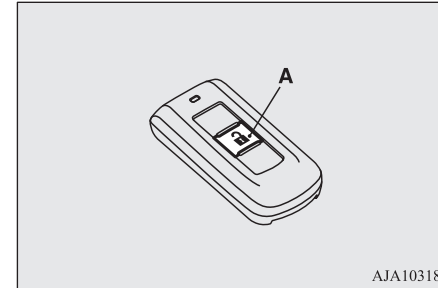

The settings mode can be toggled by pressing the UNLOCK switch. The mode can be confirmed from the number of times the buzzer sounds.

Number of times the buzzer sounds	Security alarm settings mode
1	Alarm inactive
2	Alarm active

6. Any of the following operations can be used to terminate the system settings change mode.

- Releasing the windscreen wiper and washer switch.
- Closing the driver’s door.
- Put the operation mode in ON or ACC.

Security alarm system*

- Placing the lamp switch in any position other than “OFF”.
- Allowing 30 seconds to pass without making any changes to the settings.

NOTE

- If anything with regard to making changes to the security alarm system settings is hard to understand, please consult your MITSUBISHI MOTORS Authorized Service Point.
- Avoid leaving valuable items inside the vehicle even when the security alarm system has been set to the “active” mode.

Setting the system

E00301702190

Follow the procedure below to set the system to the system armed mode.

1. Put the operation mode in OFF.
2. Exit the vehicle and close all of the doors, tailgate and bonnet.
3. Press the LOCK switch (A) on the remote control switch of the keyless operation key, the driver's or front passenger's door lock/unlock switch (B), or the tailgate LOCK switch (C) in order to lock all the doors and the tailgate.

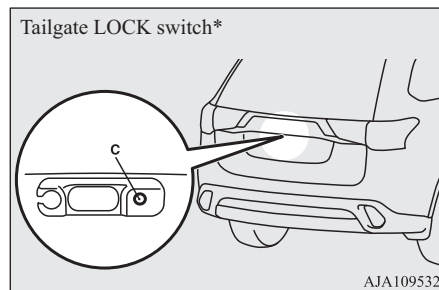
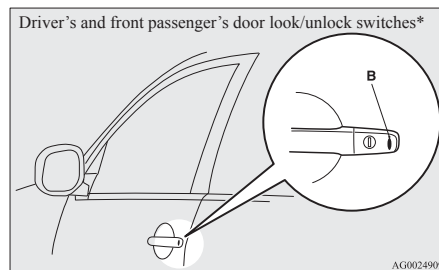
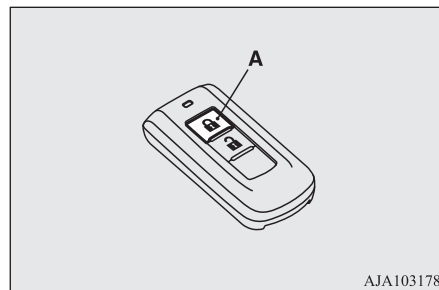

By locking the vehicle using the keyless entry system or the keyless operation function, the system preparation mode is activated.

The buzzer makes an intermittent beeping sound and the security indicator (D) in the centre panel flashes for confirmation.

4

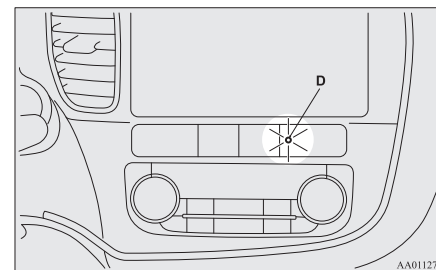

NOTE

- The system preparation mode is not activated when the doors and the tailgate have been locked using a method other than the keyless entry system or the keyless operation function (namely a key, the inside lock knob or the central door lock switch).

OGGE19E1

Security alarm system*

NOTE

- If the bonnet is open, the security indicator illuminates, and the system does not enter the system preparation mode. When the bonnet is closed, the system enters the system preparation mode, and after approximately 20 seconds the system enters the system armed mode.

4

4. After approximately 20 seconds, the buzzer stops, and when the blinking of the security indicator starts to slow down, the system armed mode goes into effect.

The security indicator continues to blink during the system armed mode.

NOTE

- The security alarm system can be activated when people are riding inside the vehicle or when the windows are open. To prevent accidental activation of the alarm, do not set the system to the system armed mode while people are riding in the vehicle.
- Avoid leaving valuable items inside the vehicle even when the security alarm system has been set to the “active” mode.

To deactivate the vehicle inclination detection function and the interior intrusion detection function*

E00312101533

The vehicle inclination detection function and the interior intrusion detection function can be deactivated when parking in automated car parks, when leaving pets in the vehicle or when leaving the vehicle with the windows slightly open.

1. Put the operation mode in OFF.
2. Raise and hold the wiper and washer switch to the “MIST” position for approximately 3 seconds. The buzzer will sound twice and the function will be deactivated.

To activate the function again, raise and hold the wiper and washer switch to the “MIST” position for approximately 3 seconds.

The buzzer will sound once and the function will be activated.

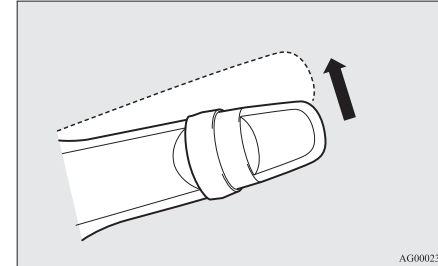

NOTE

- The function will be activated again if the following operation is performed.
 - If the doors and the tailgate are unlocked using the keyless entry system or the keyless operation function.
 - If the operation mode is put in ON or ACC.

Canceling the system

E00301802234

The following methods can be used to cancel the system when it is in the system preparation mode or the system armed mode.

- Pressing the UNLOCK switch on the remote control switch.
- Putting the operation mode in ON.

- Opening any one of the doors or the tailgate, when the system is in the system preparation mode.
- Holding the keyless operation key and pressing the driver's or front passenger's door lock/unlock switch, or the tailgate open switch to unlock the doors and the tailgate.

NOTE

- If the bonnet is opened during the system preparation mode, the system preparation mode is suspended. The system returns to the system preparation mode when the bonnet is closed.
- If the auxiliary battery terminals are disconnected while the system is in the system preparation mode, the memory will be erased.
- It is possible to register up to four remote control switches for keyless operation system. As long as they are registered, any of the remote control switches, other than the one used to activate the system, can be used to cancel the system. If you want to register additional remote control switches, please contact a MITSUBISHI MOTORS Authorized Service Point.

NOTE

- The activation distance for keyless entry system is approximately 4 m. If it is not possible to lock or unlock the vehicle by pressing the switch at the correct distance or the security alarm system cannot be set or cancelled using the switch, the battery may need to be replaced. Replace the battery at a MITSUBISHI MOTORS Authorized Service Point.
- If the UNLOCK switch on the remote control switch, or the driver's or front passenger's door lock/unlock switch is pressed and no door or the tailgate is opened within 30 seconds, the doors and the tailgate will automatically relock. In this case as well, the system preparation mode will go into effect.
- The time between pressing the UNLOCK switch on the remote control switch, or the driver's or front passenger's door lock/unlock switch and automatic locking can be adjusted. Please consult a MITSUBISHI MOTORS Authorized Service Point. On vehicles equipped with the Smartphone Link Display Audio or the MITSUBISHI Multi-Communication System (MMCS), screen operations can be used to make the adjustment. Refer to the separate owner's manual for details.

Alarm activation

E00301902408

When the system is in the system armed mode, the alarm will be activated as follows if the vehicle is unlocked or if any of the doors, tailgate or bonnet is opened using a method other than the keyless entry system or the keyless operation function.

4

1. The inside alarm will be activated for approximately 10 seconds. (except for vehicles equipped with the interior alarm sensor)

NOTE

- If the bonnet is opened during the system armed mode, the vehicle outside alarm operates immediately, without the vehicle inside alarm operating.
- The time for the vehicle inside alarm can be adjusted. Please consult a MITSUBISHI MOTORS Authorized Service Point.

2. The alarm will be activated for approximately 30 seconds. The turn-signal lamps will blink, and the horn (the siren for vehicles equipped

Electric window control

with the interior alarm sensor) will sound intermittently.

4

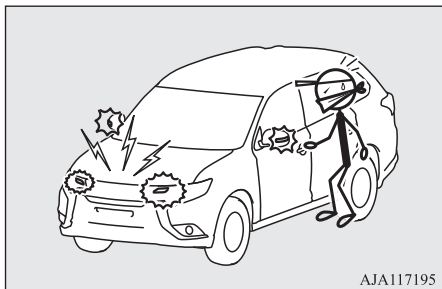

3. The alarm will resume if unlawful actions are taken again, even if the alarm has stopped.

Cancelling the alarm

E00302001890

It is possible to halt the activation of an alarm using the following methods:

- Pressing the LOCK or UNLOCK switch on the remote control switch.
(After pressing the LOCK switch, the vehicle will lock if all the doors and the tailgate are closed, after which the system preparation mode will once again go into effect.)
- Putting the operation mode in ON.

- Holding the keyless operation key and locking or unlocking the doors and the tailgate using the keyless operation function.

NOTE

- Even if a door or the tailgate is closed while the inside alarm is activating, this will not cancel the alarm activation. (except for vehicles equipped with the interior alarm sensor)
- When the operation mode is put in ON, the buzzer sounds four times. This operation indicates that the alarm was activated while the vehicle was parked.
Please check the inside of the vehicle to confirm that nothing was stolen.
- Even if the auxiliary battery is disconnected, the alarm activation memory will not be erased.

Electric window control

E00302201632

The electric windows can only be operated with the operation mode in ON.

Electric window control switch

E00302303507

Each door window opens or closes while the corresponding switch is operated.

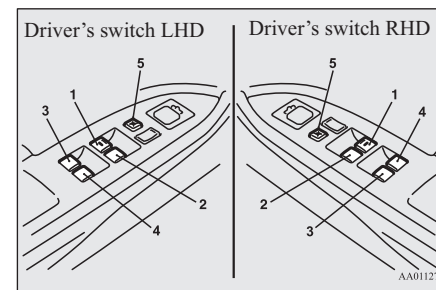

- 1- Driver's door window
- 2- Front passenger's door window
- 3- Rear left door window
- 4- Rear right door window
- 5- Lock switch

WARNING

- Before operating the electric window control, make sure that nothing can get trapped (head, hand, finger, etc.).
- Never leave the vehicle without removing the key.
- Never leave a child (or other person who might not be capable of safe operation of the electric window control) in the vehicle alone.

Driver's switches

The driver's switches can be used to operate all door windows. A window can be opened or closed by operating the corresponding switch.

Press the switch down to open the window, and pull up the switch to close it.

If the switch for the driver's window is fully pressed down/pulled up, the door window automatically opens/closes completely.

If you want to stop the window movement, operate the switch lightly in the reverse direction.

Press the switch down for opening the window, and pull up the switch for closing it.

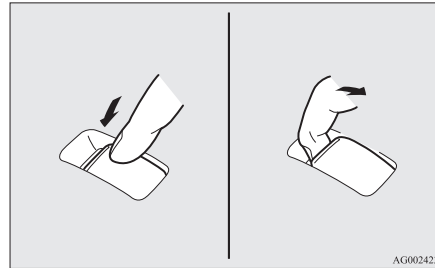

To unlock, press it once again.

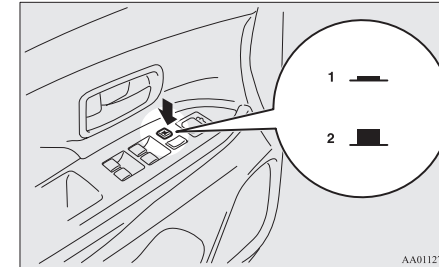

- 1- Lock
- 2- Unlock

4

NOTE

- When the door window does not close automatically even if the switch is fully pulled up, pull up the door window switch until the window has been fully closed. You should now be able to operate the door window in the normal fashion.

NOTE

- Repeated operation with the Plug-in Hybrid EV System stopped will run down the auxiliary battery. Operate the window switches only while the Plug-in Hybrid EV System is operating.
- The rear door windows only open halfway.

WARNING

- A child may tamper with the switch at the risk of its hands or head being trapped in the window. When driving with a child in the vehicle, please press the window lock switch to disable the passenger's switches.

Passenger's switches

The passenger's switches can be used to operate the corresponding passenger's door windows.

Lock switch

E00303101263

When this switch is operated, the passenger's switches cannot be used to open or close the door windows and the driver's switch cannot open or close any door windows other than the driver's door window.

Timer function

E00302402051

The door windows can be opened or closed for 30 seconds after putting the operation mode in OFF or ACC from ON. However, once the driver's door or the front passenger's door is opened, the windows cannot be operated.

Sunroof*

Safety mechanism

E00302502384

If a hand or head is trapped in the closing window, it will lower automatically. Nonetheless, make sure that nobody puts their head or hand out of the window when closing a window.

4

The lowered window will become operational after a few seconds.

WARNING

- If the auxiliary battery terminals are disconnected or the fuse for electric window is replaced, the safety mechanism will be cancelled.
If a hand or head got trapped, a serious injury could result.

CAUTION

- The safety mechanism is cancelled just before the window is fully closed. This allows the window to close completely. Therefore be especially careful that no fingers are trapped in the window.

CAUTION

- The safety mechanism is deactivated while the switch is pulled up. Therefore be especially careful that fingers are not trapped in the door window opening.

NOTE

- The safety mechanism can be activated if the driving conditions or other circumstances cause the door windows to be subjected to a physical shock similar to that caused by a trapped hand or head.
- If the following operation is performed, the safety mechanism will be cancelled and the door window will not automatically open/close completely.
 - When the auxiliary battery terminals are disconnected.
 - When the fuse for power window is replaced.
 - When the safety mechanism is activated five or more times consecutively.

In such a case, the following procedure should be implemented to rectify this situation.

If the window is open, repeatedly raise the appropriate window switch until that window has been fully closed. Following this, release the switch, raise the switch once again and hold it in this condition for at least 1 second, then release it. You should now be able to operate the door window in the normal fashion.

Sunroof*

E00302702445

The sunroof can only be operated with the operation mode in “ON”.

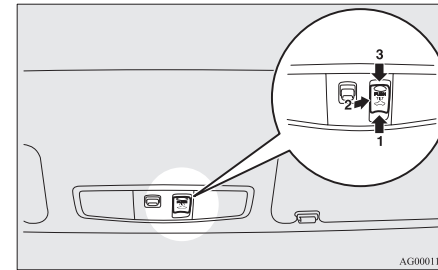

To open

The sunroof automatically opens if the switch (1) is pressed.

To stop the moving sunroof, press switch (2) or (3).

NOTE

- The sunroof automatically stops just before reaching the fully open position.
Press the switch again to fully open it.

To close

The sunroof automatically closes while the switch (3) is pressed.

To stop the moving sunroof, press switch (1) or (2).

To tilt up

When the switch (2) is pressed, the rear edge of the sunroof rises for ventilation.

To tilt down

Press the switch (3).

Safety mechanism

E00303801521

If a hand or head is trapped in the closing sunroof, it will re-open automatically. Nonetheless, make sure that nobody puts their head or hand out of the sunroof when opening or closing. The opened sunroof will become operational after a few seconds.

CAUTION

- The safety mechanism is cancelled just before the sunroof is fully closed. This allows the sunroof to close completely. Therefore be especially careful that no fingers are trapped in the sunroof.

NOTE

- The safety mechanism can be activated if the driving conditions or other circumstances cause the sunroof to be subjected to a physical shock similar to that caused by a trapped hand or head.

If the safety mechanism should be activated 5 or more times consecutively, normal closing of the sunroof will be aborted.

As an emergency measure, the sunroof can be closed bit by bit until the sunroof is completely closed by repeatedly pressing switch (2).

After that, the sunroof can be set the initialized state in the following procedure.

1. Move the sunroof in slide open position.
2. Press the tilt up switch (2) continually in 10 seconds.
3. The sunroof will be moved to tilt up position automatically bit by bit.
4. The initialize is completed when the sunroof is stopped at tilt up position.

If the sunroof does not return to normal, consult a MITSUBISHI MOTORS Authorized Service Point.

WARNING

- Before operating the sunroof, make sure that nothing is capable of being trapped (head, hand, finger, etc.).

WARNING

- Do not put head, hands or anything else out of the sunroof opening while driving the vehicle.
- Never leave the vehicle without removing the key.
- Never leave a child (or other person who might not be capable of safe operation of the sunroof switch) in the vehicle alone.

4

NOTE

- The sunroof stops just before reaching the fully open position. If the vehicle is driven with the sunroof in this position, wind buffeting is lower than with the sunroof fully open.
- When leaving the vehicle unattended, make sure you close the sunroof.
- Do not try to operate the sunroof if it is frozen closed (after snow fall or during extreme cold).
- Do not sit or place heavy luggage on the sunroof or roof opening edge.
- Release the switch as soon as the sunroof reaches the fully open or fully closed position.
- If the sunroof does not operate when the sunroof switch is operated, release the switch and check whether something is trapped by the sunroof. If nothing is trapped, have the sunroof checked at a MITSUBISHI MOTORS Authorized Service Point.

Sunroof*

NOTE

- Depending on the models of ski carriers or roof carriers, the sunroof may touch the carrier when the sunroof is tilted up. Be careful when tilting up the sunroof if such a ski carrier or a roof carrier is installed.
- Be sure to close the sunroof completely when washing the vehicle or when leaving the vehicle.
- Be careful, not to put any wax on the weatherstrip (black rubber) around the sunroof opening. If stained with wax, the weatherstrip cannot maintain a weatherproof seal with the sunroof.
- After washing the vehicle or after it has rained, wipe off any water that is on the sunroof before operating it.

4

CAUTION

- Be careful that hands are not trapped when closing the sunshade.

NOTE

- The sunshade cannot be closed with the sunroof opened. Do not attempt to close the sunshade when the sunroof is opened.

Sunshade

E00307901227

Slide the sunshade manually to open and close it.

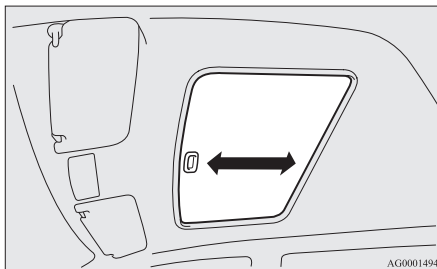

Seats and seat belts

Seat arrangement.....	5-02
Seat adjustment.....	5-02
Front seats.....	5-03
Rear seats.....	5-05
Head restraints.....	5-05
Making a luggage area.....	5-06
Making a flat seat.....	5-08
Seat belts.....	5-09
Pregnant women restraint.....	5-14
Seat belt pretensioner system and force limiter system.....	5-14
Child restraint.....	5-15
Seat belt inspection.....	5-25
Supplemental restraint system (SRS)-airbag.....	5-25



Seat arrangement

Seat arrangement

E00400201886

By operating the front or rear seat, select the desired seat arrangement.

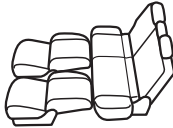
5

Normal usage		 AGM000168
Flat seat → p. 5-08		 AGM000285
Making a luggage area	Folding the rear seats → p. 5-06	 AAM008704

Seat adjustment

E00400302057

Adjust the driver's seat so that you are comfortable and that you can reach the pedals, steering wheel, switches etc. while retaining a clear field of vision.

5-02 Seats and seat belts

OGGE19E1

WARNING

- Do not attempt to adjust the seat while driving. This can cause loss of vehicle control and result in an accident. After adjustments are made, ensure the seating is locked in position by attempting to move the seat forward and rearward without using the adjusting mechanism.
- Do not allow people or children to ride in any area of your vehicle that is not equipped with seats and seat belts, and make sure that everyone travelling in your vehicle is in a seat and wearing a seat belt, or in the case of a child is strapped in a child restraint.
- To minimize the risk of personal injury in the event of a collision or sudden braking, the seatbacks should always be in the almost upright position while the vehicle is in motion. The protection provided by the seat belts may be reduced significantly when the seatback is reclined. There is greater risk that the passenger will slide under the seat belt, resulting in serious injury, when the seatback is reclined.
- Do not place objects under the seats. This could prevent the seat from locking securely, and it could lead to an accident. It may also cause damage to the seat or other parts.

CAUTION

- Make sure the seat is adjusted by an adult or with adult supervision for correct and safe operation.
- Do not place a cushion or the like between your back and the seatback while driving. The effectiveness of the head restraints will be reduced in the event of an accident.
- The reclining mechanism of the front seat's seatback is spring loaded, causing it to return to the vertical position when the lock lever is operated. When using the lever, sit close to the seatback or hold it with your hand to control its return motion.
- When sliding the seats, be careful not to catch your hand or foot.
- When adjusting the front seat while the rear seat is folded, be careful not to apply strong force to the flipped rear seat cushion. Doing so could cause damage to the cover of the front seat and the fitting of the rear seat cushion.

Front seats

E00400401253

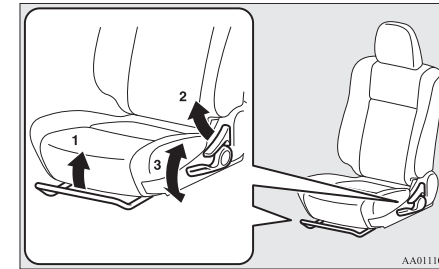
Manual type**5**

- 1- To adjust forward or backward
Lift the handle and adjust the seat to the desired position, and release the handle.
- 2- To recline the seatback
Pull the lever up and then lean backward to the desired position, and release the lever.
- 3- To adjust seat height (driver's side only)
Repeatedly operate the lever and adjust the seat height to the desired position.

Front seats

Power type*

5

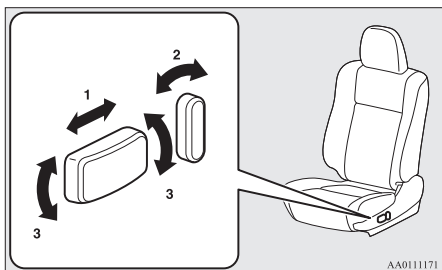

1- To adjust forward or backward

Operate the switch as indicated by the arrows and adjust the seat to the desired position.

2- To recline the seatback

Operate the switch as indicated by the arrows and adjust the seatback angle to the desired position.

3- To adjust seat height

Operate the switch as indicated by the arrows and adjust the seat height to the desired position.

If the entire switch is operated, then the entire seat moves.

Heated seats*

E00401102371

The heated seats can be operated with the operation mode of the power switch in ON. Operate the switch as indicated by arrows.

5-04 Seats and seat belts

The indication lamp (A) will illuminate while the heater is on.

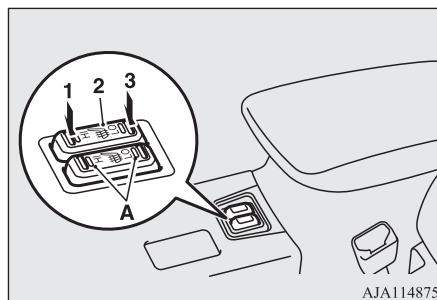

1 (HI) - Heater high (for quick heating).

2 (neu - Heater off.

tral po-
sition)

3 (LO) - Heater low (to keep the seat warm).

CAUTION

- Operate in the high position for quick heating. Once the seat is warm, set the heater to low to keep it warm. Slight variations in seat temperature may be felt while using the heated seats. This is caused by the operation of the heater's internal thermostat and does not indicate a malfunction.

CAUTION

- If the following types of persons use the heated seats, they might become too hot or receive minor burns (red skin, heat blisters, etc.):
 - Children, elderly or ill people
 - People with sensitive skin
 - Excessively tired people
 - People under the influence of alcohol or sleep inducing medication (cold medicine, etc.)
- Do not place heavy objects on the seat or stick pins, needles, or other pointed objects into it.
- Do not use a blanket, cushion, or other material with high heat insulation properties on the seat while using the heater; this might cause the heater element to overheat.
- Do not use benzine, kerosene, petrol, alcohol or other organic solvents when cleaning the seats. Doing so could damage not only the seat cover, but also the heater element.
- If water or any other liquid is spilled on the seat, allow it to dry thoroughly before attempting to use the heater. Turn the heater off immediately if it appears to be malfunctioning during use.

Rear seats

E00401301549

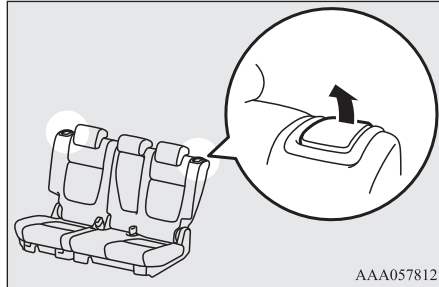

AAA057812

To return to the original position, push it backward level with the seat.

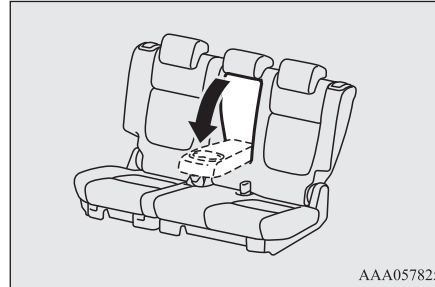

AAA057825

To adjust the seatback, pull the lever up and adjust the seatback by hand to the desired position, and release the lever.

Armrest

E00401701732

To use the armrest, fold it down.

NOTE

- Do not climb or sit on the armrest. Doing so could damage the armrest.
- The top surface of the armrest contains a cup holder for rear seat occupants. Refer to “Cup holder” on page 8-84.

Head restraints

E00403302654

WARNING

- Driving without the head restraints in place can cause you and your passengers serious injury or death in an accident. To reduce the risk of injury in an accident, always make sure the head restraints are installed and properly positioned when the seat is occupied.

OGGE19E1

WARNING

- Never place a cushion or similar device on the seatback. This can adversely affect head restraint performance by increasing the distance between your head and the restraint.
- When a person sits in the rear seats, pull up the head restraint to a height at which it locks in position. Be sure to make this adjustment before starting to drive. Serious injuries could otherwise be suffered as the result of an impact.

5

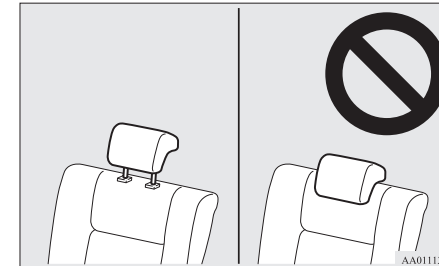

AA011357

To adjust height

Adjust the head restraint height so that the centre of the head restraint is as close as possible to ear level to reduce the chances of injury in the event of collision. Any person too tall for the head restraint to reach their seated ear level, should adjust the restraint as high as possible.

Making a luggage area

To raise the head restraint, move it upward. To lower the restraint, move it downward while pushing the height adjusting knob (A) in the direction of the arrow. After adjustment, push the head restraint downward and make sure that it is locked.

5

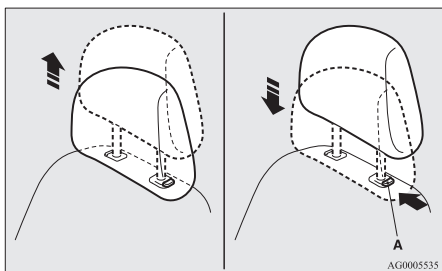

To remove

Lift the head restraint with the height adjusting knob (A) pushed in.

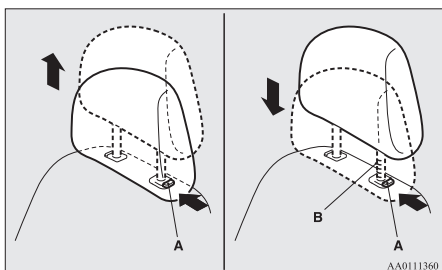

To install

Confirm that the head restraint is facing the correct direction, and then insert it into the seatback while pressing the height adjusting knob (A) in the direction indicated by the arrow.

The head restraint stalk with the adjustment notches (B) must be installed in the hole with the adjusting knob (A).

CAUTION

- Confirm that the height adjusting knob (A) is correctly adjusted as shown in the illustration, and also lift the head restraints to ensure that they do not come out of the seatback.

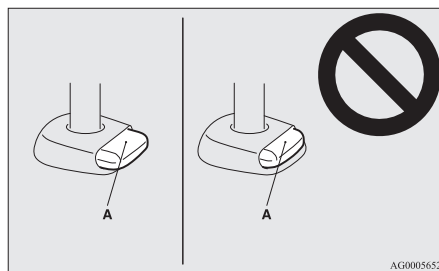

CAUTION

- The shape and size of the head restraint differs according to the seat. Always use the correct head restraint provided for the seat and do not install the head restraint in the wrong direction.

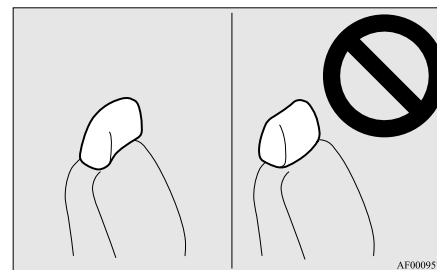

Making a luggage area

E00403401502

To create luggage space, you can fold the rear seats.

CAUTION

- Do not stack luggage above the seatback height. Secure the luggage firmly. Serious accidents could result due to unrestrained objects entering the passenger compartment during sudden braking.

Making a luggage area

CAUTION

- When folding the seat, be sure not to catch your hand or leg.

NOTE

- It is possible to fold the seat independently on each side.

To fold

1. Lower the head restraints of the rear seat to the lowest position.
Refer to “Head restraints” on page 5-05.
2. Store the seat belt for the rear centre seating position.
Refer to “Rear-centre 3-point type seat belt” on page 5-13.
3. Lift the front end of the seat cushion.

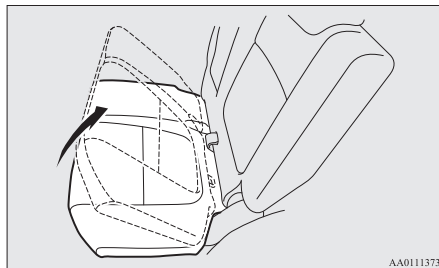

4. Flip the seat cushion forward.

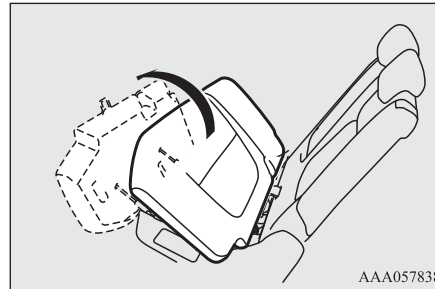

5. Fold the seat belt buckles forward.

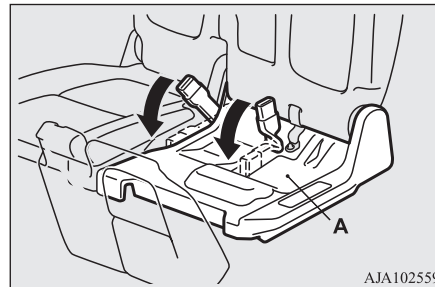

CAUTION

- Do not allow any person to get on the plastic cover (A), and do not place luggage on it. Doing so could damage cover.

6. Pull up the lever, then fold the seatback forward.

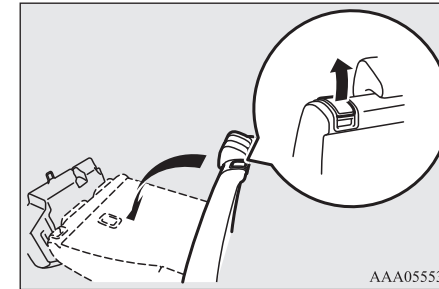

5

CAUTION

- Do not allow any person to sit on the flipped seat cushion, and do not place luggage on it. The seat's mounting fittings could bend under the weight, making it impossible for the seat to be retained on the vehicle.

To return

1. Raise the seatback until it locks securely into place.

Making a flat seat

2. While lifting the seat belt's buckle (A), gently lower the seat cushion. Make sure that there is a hook (B) at the position shown in the illustration.

5

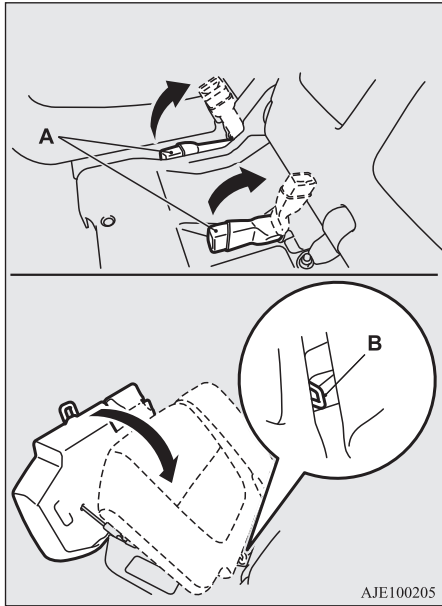

3. Push down the seat cushion until it locks into place.

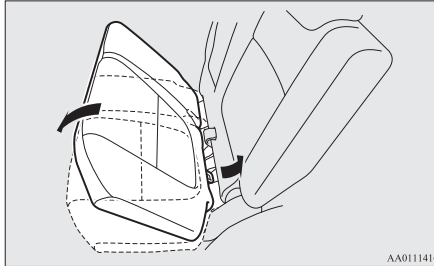

4. Make sure the seat belt's buckle is on the seat cushion.

Making a flat seat

E00404301931

By removing the head restraints and fully reclining the seatbacks of the seats, one large flat seat is achieved.

WARNING

- Never drive with passengers on the flat seat. This is highly dangerous.

CAUTION

- To make a flat seat, stop the vehicle in a safe place.
- Make sure the seat is adjusted by an adult or with adult supervision for correct and safe operation.
- Do not walk around on top of the seats after they have been laid flat.
- To ensure the seats are locked securely, attempt to move them back and forth.
- Do not jump on, or impact the seatbacks heavily.
- To raise the seatback, put a hand on the seatback and raise slowly. Never have a child do this operation, or an unexpected accident may result.

1. Remove the head restraints from the front seats, raise the armrest and remove the cargo area cover. (Refer to "Head restraints" on page 5-05, "Armrest" on page 5-05 and "Cargo area cover" on page 8-85)

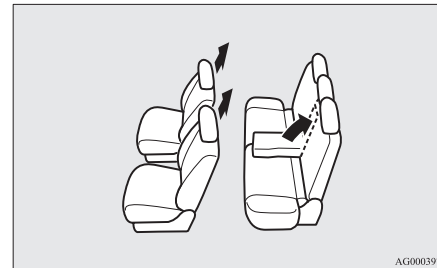

2. Slide the front seats fully forward, then recline the seatbacks backwards to achieve a flat surface. (Refer to “Front seats” on page 5-03)

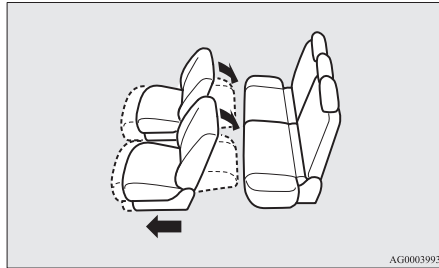

4. The flat seat configuration is now complete. Reverse the above procedures when returning the seat to the normal position.

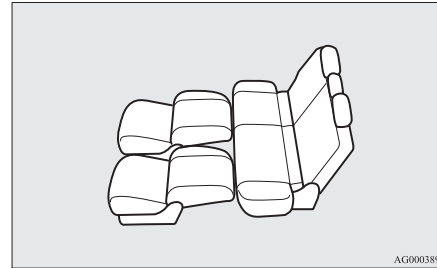

3. Recline the rear seatbacks backwards. (Refer to “Rear seats” on page 5-05)

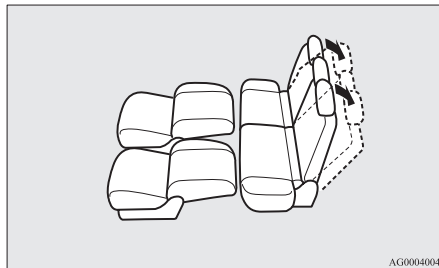

Seat belts

E00404800867

To protect you and your passengers in the event of an accident, it is most important that the seat belts be worn correctly while driving. The front seat belts have a pretensioner system. These belts are used the same way as a conventional seat belt. Refer to “Seat belt pretensioner system and force limiter system” on page 5-14.

⚠ WARNING

- Seat belts should always be worn by every adult who drives or rides in this vehicle, and by all children who are tall enough to wear seat belts properly. Other children should always use proper child restraint systems.
- Always place the shoulder belt over your shoulder and across your chest. Never put it behind you or under your arm.
- One seat belt should be used by only one person. Doing otherwise can be dangerous.
- The seat belt will provide its wearer with maximum protection if the recliner seatback is placed in fully upright position. When the seatback is reclined, there is greater risk that the passenger will slide under the belt, especially in a forward impact accident, and may be injured by the belt or by striking the instrument panel or seatbacks.
- Remove any twists when using the belt.
- No modifications or additions should be made by the user which will either prevent the seat belt adjusting devices from operating to remove slack, or prevent the seat belt assembly from being adjusted to remove slack.
- Never hold a child in your arms or on your lap when riding in this vehicle, even if you are wearing your seat belt. To do so risks severe or fatal injury to the child in a collision or sudden stop.

Seat belts

⚠ WARNING

- Always adjust the belt to a snug fit.
- Always wear the lap portion of the belt over your hips.

5

3-point type seat belt (with emergency locking mechanism)

E00404902918

This type of belt requires no length adjustment. Once worn, the belt adjusts itself to the movement of the wearer, but in the event of a sudden or strong shock, the belt automatically locks to hold the wearer's body.

📖 NOTE

- You can check if the belt locks by pulling it forward quickly.
- If the seat belt buckles in the rear seating position are not found, you will find them under the rear seat cushion. Refer to "Making a luggage area" on page 5-06 for how to put the seat belt buckles at the proper position.

To fasten

1. Pull the seat belt out slowly while holding the latch plate.

📖 NOTE

- When the seat belts cannot be pulled out in a locked condition, pull the belts once forcefully and then return them. After that, pull the belts out slowly once again.

2. Insert the latch plate into the buckle until a "click" is heard.

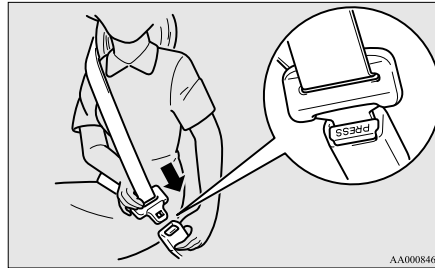

⚠ WARNING

- Never wear the lap portion of the belt across your abdomen. During accidents it can press sharply against the abdomen and increase the risk of injury.
- The seat belts must not be twisted when worn.

3. Pull the belt slightly to adjust slackness as desired.

To unfasten

Hold the latch plate and push the button on the buckle.

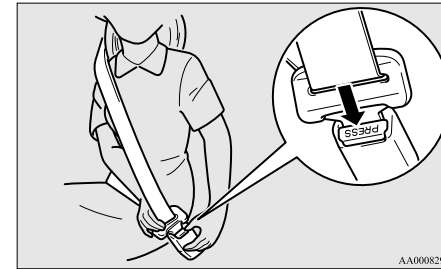

📖 NOTE

- As the belt retracts automatically, keep holding the latch plate while retracting so that the belt stows slowly. Failure to do this could damage the vehicle.

NOTE

- If the seat belt (A) or ring (B) becomes dirty, the belt may not retract smoothly. If the seat belt and ring are dirty, clean them with a mild soap or detergent solution.

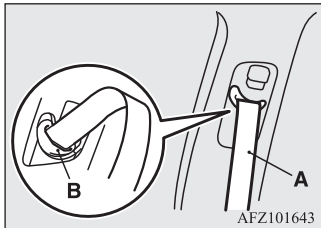

Seat belt reminder

E00409801973

For the driver and the front passenger's seat

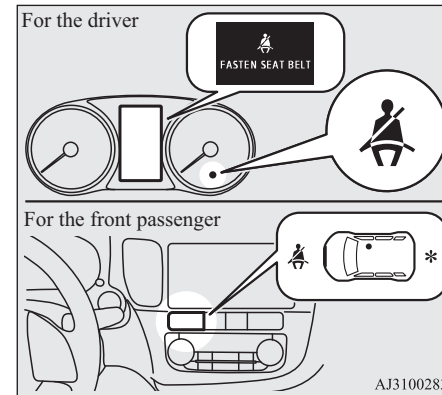

*- This warning lamp shows the case of the left-hand drive vehicles.

If the operation mode of the power switch is put in ON while a seat belt is not fastened, the warning lamp comes on and the tone sounds for about 6 seconds to remind the driver and the front passenger to fasten the seat belt.

If the vehicle is driven with the seat belt still unfastened, the warning lamp will blink and the tone will sound intermittently until the seat belt is fastened. At the same time, "FASTEN SEAT BELT" is displayed on the information screen in the multi information display for the driver.

WARNING

- Do not install any accessory or sticker that makes the lamp difficult to see.

NOTE

- If the seat belt subsequently remains unfastened, the warning lamp and the tone will issue further warnings each time the vehicle starts moving from a stop.
- For the front passenger seat, the warning function works only while a person is sitting on the seat.
- When luggage is placed on the front passenger seat, a sensor in the seat cushion may, depending on the weight and position of the luggage, cause the warning tone to sound and the warning lamp to come on.

5

Seat belts

For the rear passenger's seats

E00415501021

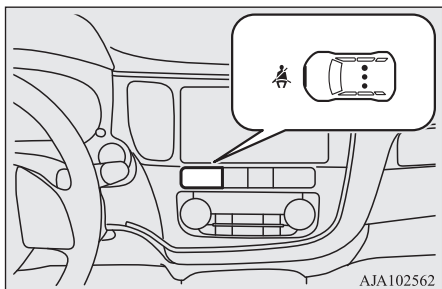

If the operation mode of the power switch is put in ON while a seat belt is not fastened, the warning lamp comes on for approximately 30 seconds to remind the rear passenger to fasten the seat belt.

If the vehicle is driven with the seat belt still unfastened, the warning lamps come on for approximately another 30 seconds. (This illumination happens only the first time the vehicle starts moving with the seat belt still unfastened.)

The warning lamps go off when the seat belt is fastened.

⚠ WARNING

- Do not install any accessory or sticker that makes the lamp difficult to see.

📖 NOTE

- The warning lamp comes on even if no one is sitting on the rear seats.
- If a seat belt is unfastened while the vehicle is being driven, the tone sounds for approximately 1 second and the warning lamp comes on for approximately 30 seconds. At the same time, the warning lamp for the seat where the seat belt is not fastened comes on.
- If the seat belts are initially fastened but a seat belt is unfastened while the vehicle is stationary and the vehicle is then driven with the seat belt still unfastened, the warning lamp comes on again for approximately 30 seconds.

Adjustable seat belt anchor (front seats)

E00405000420

The seat belt anchor height can be adjusted.

Move the seat belt anchor down with the lock knob (A) depressed. To move the anchor up, slide it without depressing the lock knob (A).

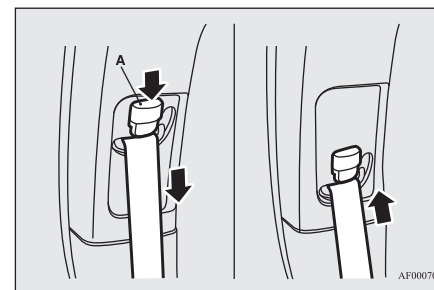

⚠ WARNING

- When adjusting the seat belt anchor, set it at a position that is sufficiently high so that the belt will make full contact with your shoulder but will not touch your neck.

Rear-centre 3-point type seat belt

E00405201184

The rear-centre 3-point type seat belt must be worn correctly as illustrated.

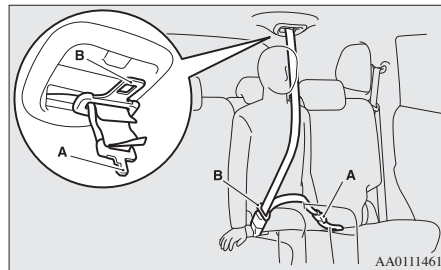

⚠ WARNING

- Be sure to securely connect the both latch plate (A and B). Failing to do so could significantly reduce the amount of protection and cause serious injuries in a collision or a sudden stop.

📖 NOTE

- If the seat belt buckles in the rear seating position are not found, you will find them under the rear seat cushion. Refer to “Making a luggage area” on page 5-06 for how to put the seat belt buckles at the proper position.

To fasten

1. Pull out the buckle (C) from the seat-back.
2. Pull out the small latch plate (A) and then pull out the latch plate (B) by tilting it as shown in the illustration.

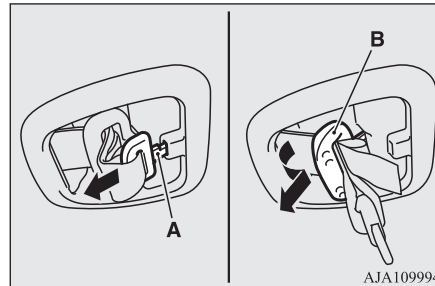

📖 NOTE

- Pulling out the latch plate by force may damage the headliner.

3. Pull the seat belt and insert the small latch plate (A) into the buckle (C).

4. Insert the latch plate (B) into the buckle (D).

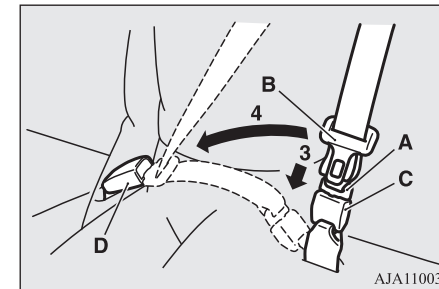

5

5. Pull the belt slightly to adjust slackness as desired.

To unfasten

1. Hold the latch plate and push the button on the buckle.

📖 NOTE

- As the belt retracts automatically, keep holding the latch plate while retracting so that the belt stows slowly. Failure to do this could damage the vehicle.
- To release the buckle (C), press the button (E) with a narrow-tipped object (latch plate or mechanical key etc.).

Pregnant women restraint

5

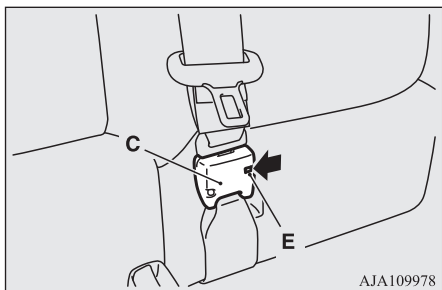

AJA109978

2. After the seat belt is retracted completely, insert the latch plate (B) into the upper slit (F), and then insert the small latch plate (A) into the lower slit (G).

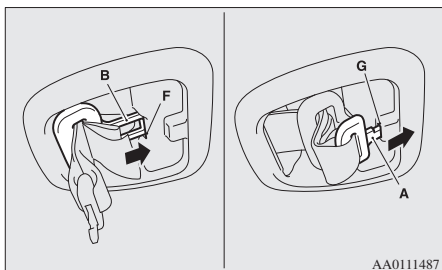

AA0111487

3. Store the seat belt buckle in the storage pocket.
(Refer to next column.)

Rear seat belt storage

E00405301521

When the seat belt is not in use, store it as shown in the illustration.

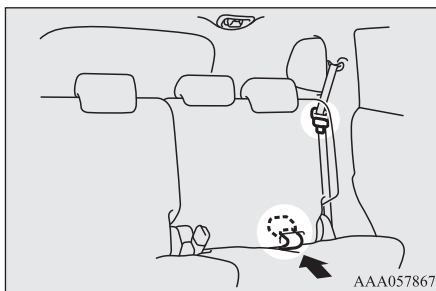

AAA057867

Seat belt plate storage

Outboard seating position

After passing the belt through the rear notch (A), insert the plate into the front notch (B).

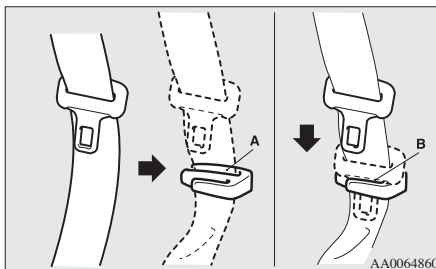

AA0064860

Pregnant women restraint

E00405600077

⚠ WARNING

- Seat belts work for everyone, including pregnant women. Pregnant women should use the available seat belts. This will reduce the likelihood of injury to both the woman and the unborn child. The lap belt should be worn across the thighs and as snug against the hips as possible, but not across the waist. Consult your doctor if you have any additional questions or concerns.

Seat belt pretensioner system and force limiter system

E00405701323

The driver's seat and front passenger's seat each have a seat belt equipped with a pretensioner system and force limiter system.

Pretensioner system

E00405802523

When the operation mode of the power switch is in ON, if there is a frontal impact or a side impact severe enough to injure the driver and/or front passenger, the pretensioner system will retract their respective seat belts instantaneously, thus maximizing the seat belt's effectiveness.

WARNING

- To obtain the best results from your pretensioner seat belt, make sure you have adjusted your seat correctly and wear your seat belt properly.

CAUTION

- Installation of audio equipment or repairs in the vicinity of the pretensioner seat belts or floor console must be performed in line with MITSUBISHI MOTORS guidelines. It is important to do so because the work could affect the pretensioner systems.
- If you need to scrap the vehicle, please consult a MITSUBISHI MOTORS Authorized Service Point.
It is important to do so because unexpected activation of the pretensioner seat belts could cause injuries.

NOTE

- The pretensioner seat belts will be activated if the vehicle suffers a severe impact, even if the seat belts are not worn.
- The pretensioner seat belts are designed to work only once. After the pretensioner seat belts have been activated, we recommend you have it replaced by a MITSUBISHI MOTORS Authorized Service Point.

SRS warning

E00405900360

The same warning lamp/display is shared by the SRS airbags and the pretensioner seat belts.

Refer to "SRS warning lamp/display" on page 5-35.

Force limiter system

E00406000209

In the event of a collision, each force limiter system will effectively absorb the load applied to the seat belt to minimize the impact to the passenger.

Child restraint

E00406403507

When transporting children in your vehicle, some type of child restraint system should always be used according to the size of the child. This is required by law in most countries.

The regulations concerning driving with children in the front seat may differ from country to country. You are advised to comply with the relevant regulations.

WARNING

- When possible, put children in the rear seat. Accident statistics indicate that children of all sizes and ages are safer when properly restrained in the rear seat rather than in the front seat.
- Holding a child in your arms is no substitute for a restraint system. Failure to use a proper restraint system can result in severe or fatal injury to the child.
- Each child restraint device or fixing is to be used only by one child.
- When attaching a child restraint system to the rear seat, prevent the front seat-backs from touching the child restraint system.
Otherwise, the child could be seriously injured in the event of hard braking or a collision.

5

Child restraint

Caution for installing the child restraint on vehicles with front passenger's airbag

The label shown here is attached on vehicles with a front passenger's airbag.

5

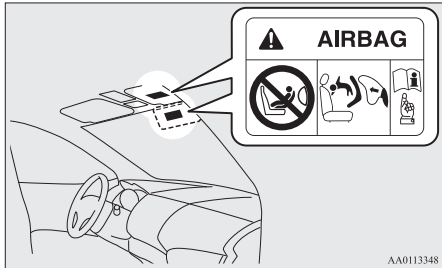

⚠ WARNING

- **Extreme Hazard!**
NEVER use a rearward facing child restraint on a seat protected by an ACTIVE AIRBAG in front of it, DEATH or SERIOUS INJURY to the CHILD can occur.

Use rearward facing child restraints in the rear seat or turn off the front passenger's airbag ON-OFF switch. (Refer to "To turn an airbag off" on page 5-28)



⚠ WARNING

- A REARWARD FACING CHILD RESTRAINT must NOT be used in the front passenger seat if the front passenger's airbag has not been deactivated. The force of an inflating airbag could kill or cause serious injuries to the child. A rearward facing child restraint should be used in the rear seat.
- A FORWARD FACING CHILD RESTRAINT should be used in the rear seat whenever possible; if it must be used in the front passenger seat, turn off the front passenger's airbag ON-OFF switch. Failure to do so could kill or cause serious injuries to the child.

⚠ WARNING

- A REARWARD FACING CHILD RESTRAINT must NOT be used in the front passenger seat when the driver's visibility is obstructed.

Infants and small children

E00406602065

When transporting infants and small children in your vehicle, follow the instruction given below.

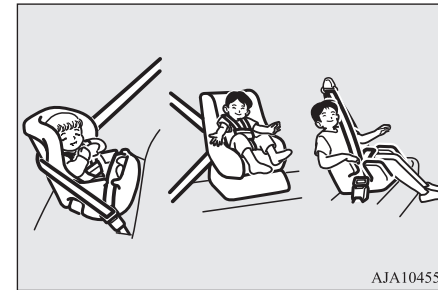

Instruction:

- For small infants, an infant carrier should be used. For small children whose height when seated allows the shoulder belt to lie in contact with the face or the throat, a child seat should be used.

- The child restraint system should be appropriate for the child's weight and height and properly fit in the vehicle. For a higher degree of safety: **THE CHILD RESTRAINT SYSTEM SHOULD BE INSTALLED IN THE REAR SEAT.**

 **NOTE**

- Before purchasing a child restraint system, try installing it to make sure there is a good fit. Because of the location of the seat belt buckles and the shape of the seat cushion, it may be difficult to securely install some manufacturer's child restraint systems. If the child restraint system can be pulled forward or to either side easily on the seat cushion after the seat belt has been tightened, choose another manufacturer's child restraint system.

 **WARNING**

- **When installing a child restraint system, refer to the instructions provided by the manufacturer of the restraint system. Failure to do so can result in severe or fatal injury to the child.**

 **WARNING**

- **After installation, push and pull the child restraint system back and forth, and side to side, to see that it is properly secured. If the child restraint system is not installed securely, it may cause injury to the child or other occupants in the case of accident or sudden stops.**
- **When the child restraint system is not in use, keep your child restraint system secured with the seat belt or remove it from the vehicle in order to prevent it from being thrown around inside the vehicle during an accident.**

Depending on the seating position in the vehicle and the child restraint system that you have, the child restraint can be attached using one of the following two ways:

- Using the lower anchorage in the front passenger seat or the rear seat if the child restraint has ISOFIX mountings (See page 5-22).
- Using the seat belt (See page 5-24).

Older children

E00406700307

Children who have outgrown the child restraint system should be seated in the rear seat and wear combination lap shoulder belt.

The lap portion of the belt should be snug and positioned low on the abdomen so that it is below the top of the hip-bone. Otherwise, the belt could intrude into the child's abdomen during an accident and cause injury.

Child restraint

Suitability for various ISOFIX positions

E00411402393

5

Mass group	Size class	Fixture	Vehicle ISOFIX positions			Recommended Child Restraint Systems*2	UN-R44 Approval No.	UN-R129 Approval No.
			Front passenger		Rear out-board			
			Activated air-bag	Deactivated Airbag*1				
Carrycot	F	ISO/L1	X	X	X	—	—	—
	G	ISO/L2	X	X	X	—	—	—
0 -Up to 10 kg	E	ISO/R1	X	IL	IL	—	—	—
0+ -Up to 13 kg	E	ISO/R1	X	IL	IL	—	—	—
	D	ISO/R2	X	IL, IL#	IL, IL#	BABY-SAFE i-SIZE: MZ3150 55 BABY-SAFE i-SIZE FLEX BASE: MZ3150 56	—	E1-0000 08
	C	ISO/R3	X	X	IL	—	—	—
I-9 to 18 kg	D	ISO/R2	X	X	IL	—	—	—
	C	ISO/R3	X	X	IL	—	—	—

Mass group	Size class	Fixture	Vehicle ISOFIX positions			Recommended Child Restraint Systems*2	UN-R44 Approval No.	UN-R129 Approval No.
			Front passenger		Rear out-board			
			Activated air-bag	Deactivated Airbag*1				
	B	ISO/F2	X	IUF	IUF	—	—	—
	B1	ISO/F2X	X	IUF, IL#	IUF, IL#	DUO plus: MZ313045	E1-04301133	—
	A	ISO/F3	X	IUF	IUF	—	—	—
II - 15 to 25 kg			X	IL#	IL#	KIDFIX XP: MZ315025	E1-04301304	—
III - 22 to 36 kg			X	IL#	IL#			—

5

*1: With front passenger's airbag deactivated by means of front passenger's airbag ON-OFF switch.

*2: MITSUBISHI MOTORS Europe B.V. reserves the right to changes without any prior announcement.

For detailed information, consult your MITSUBISHI MOTORS Authorized Service Point.

CAUTION

- When installing a child restraint system, remove the head restraint from the seat.
- When installing a child restraint system on the rear outboard seat, adjust the seatback angle to 4 steps forward from the most reclined position.
- A rearward facing child restraint system is not recommended for front passenger seat because driver's visibility may be obstructed. If the driver's visibility is obstructed, install a child restraint system on the rear seat.
- Do not sit in the middle seating position of the rear seat when installing a child restraint system to the left outboard seating position of the rear seat. Because the child restraint interferes with the seat belt, you cannot fasten the seat belt correctly.
- "BABY-SAFE i-SIZE" and "BABY-SAFE i-SIZE FLEX BASE" are designed for children 40 to 83 cm in height.

Child restraint

Definition of characters the above table:

- IUF- Suitable for ISOFIX forward child restraint systems of universal category approved for use in the mass group.
- IL- Suitable for ISOFIX child restraint systems of semi-universal category approved for use in the mass group.
- IL#- Suitable for particular ISOFIX child restraint systems. See the above table of “Recommended Child Restraint Systems”.
- X- ISOFIX position not suitable for ISOFIX child restraint systems in this mass group.

5 Suitability for various seating positions

E00406803240

Mass group	Seating position				Recommended Child Restraint Systems*2	UN-R44 Approval No.	UN-R129 Approval No.
	Front passenger		Rear out-board	Rear centre			
	Activated airbag	Deactivated Airbag*1					
0 -Up to 10 kg	X	U	U	X	—	—	—
0+ - Up to 13 kg	X	U, L#	U, L#	X	BABY-SAFE i-SIZE: MZ315055	—	E1-000008
I -9 to 18 kg	X	U, L#	U, L#	X	DUO plus: MZ313045	E1-04301133	—
II - 15 to 25 kg	X	U*3, L#	U*3, L#	X	KIDFIX XP: MZ315025	E1-04301304	—
III - 22 to 36 kg	X	U*3, L#	U*3, L#	X			

*1: With front passenger's airbag deactivated by means of front passenger's airbag ON-OFF switch

*2: MITSUBISHI MOTORS Europe B.V. reserves the right to changes without any prior announcement.

For detailed information, consult your MITSUBISHI MOTORS Authorized Service Point.

*3: Do not remove the head restraint when installing a “universal” category booster cushion.

⚠ CAUTION

- When installing a child restraint system, remove the head restraint from the seat. However, do not remove the head restraint when installing a booster cushion (see page “Installing a child restraint system to a 3-point type seat belt (with emergency locking mechanism)” on page 5-24).
- When installing a child restraint system on the front passenger seat, adjust the front seatback angle to 2 steps rearward from the first locking position.
- Do not sit in the middle seating position of the rear seat when installing a child restraint system to the left outboard seating position of the rear seat. Because the child restraint interferes with the seat belt, you cannot fasten the seat belt correctly.
- “BABY-SAFE i-SIZE” is designed for children 40 to 83 cm in height.

5**Definition of characters the above table:**

- U- Suitable for “universal” category restraints approved for use in this mass group.
- L#- Suitable for particular child restraint systems. See the above table of “Recommended Child Restraint Systems”.
- X- Seat position not suitable for children in this mass group.

Child restraint

Installing a child restraint system to the lower anchorage (ISOFIX child restraint mountings) and tether anchorage

E00406901944

5

Lower anchorage location

Your vehicle's front passenger seat and rear seat is fitted with lower anchorages for attaching a child restraint system with ISOFIX mountings.

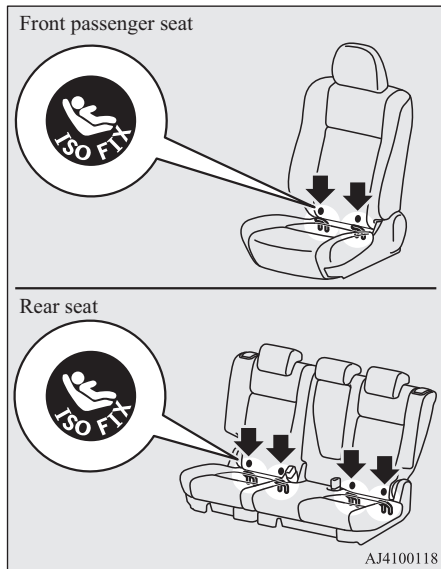

Tether anchorage location

Your vehicle has 3 child restraint anchorage points on the backside of the front passenger seat and rear seats. These are for securing a child restraint system tether strap to each of the 3 seating positions in your vehicle.

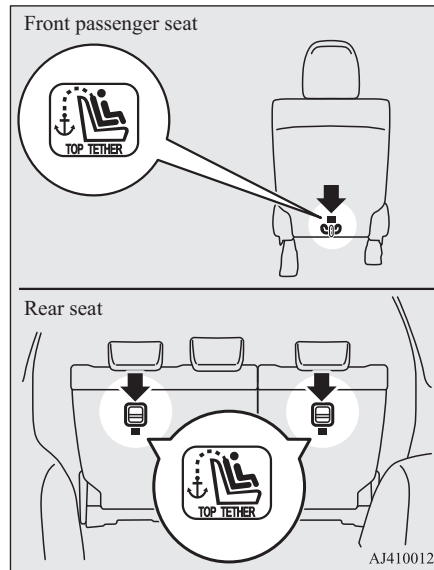

WARNING

- Child restraint anchorages are designed to withstand only those loads imposed by correctly fitted child restraints. Under no circumstances are they to be used for adult seat belts, harnesses, or for attaching other items or equipment to the vehicle.

Child restraint system with ISOFIX mountings

The child restraint system is designed only for seats that incorporate lower anchorages. Retain the child restraint system using the lower anchorages.

It is not necessary to retain the child restraint system using the vehicle's seat belts.

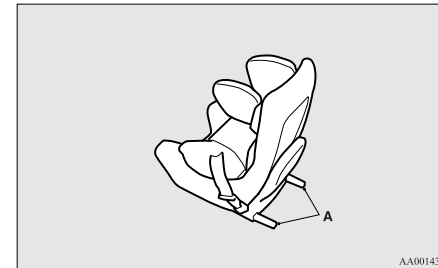

A- Child restraint system connectors

To install

1. Remove any foreign material in or around the connectors and ensure the vehicle seat belt is in its normal storage position.
2. Remove the head restraint from the location in which you wish to install a child restraint. Refer to “Head restraints” on page 5-05.
3. When installing a child restraint system in the front passenger seat, adjust seat slide to its most rearward position.

4. Push the child restraint system’s connectors (A) into the lower anchorages (B) in accordance with the instructions provided by the child restraint system’s manufacturer.
For easier access to the rear seat lower anchorage, the rear seatback may be recline rearward. After it is security fastened, adjust the seatback to 4 steps forward from most reclined position.

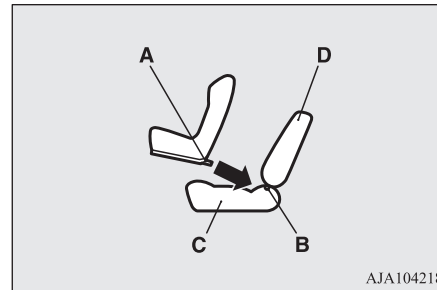

- A- Connector
- B- Lower anchorage
- C- Vehicle seat cushion
- D- Vehicle seatback

If your child restraint system has a support leg, make sure that there is a support leg at the stable position on the floor.

If your child restraint system requires the use of a tether strap, fasten the tether strap in accordance with step 5.

- 6.
5. Latch the tether strap hook (E) of the child restraint system to the tether anchorage bar (F) and tighten the top tether strap hook so it is securely fastened.

5

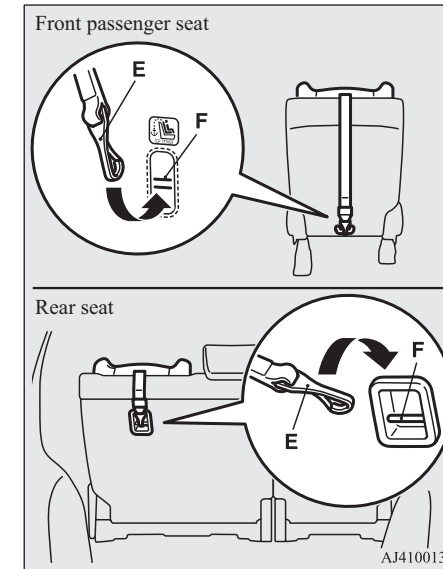

Child restraint

NOTE

- If it is difficult to latch the tether strap hook in the rear seat, turn the hook sideways.

6. Push and pull the child restraint system in all directions to be sure it is secure.

5 To remove

Remove the child restraint system in accordance with the instructions provided by the child restraint system's manufacturer.

Installing a child restraint system to a 3-point type seat belt (with emergency locking mechanism)

E00408702060

Installation:

1. Put a child restraint system on the seat in which you wish to install it, and remove the head restraint from the seat. Refer to "Head restraints" on page 5-05.

CAUTION

- Do not remove the head restraint when installing a booster cushion.

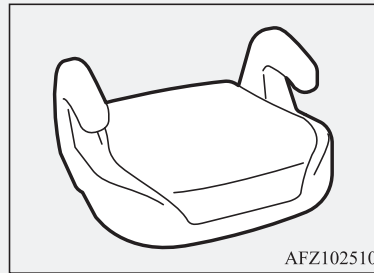

2. When installing a child restraint system in the front passenger seat, adjust seat slide to its most rearward position and adjust the front seatback angle to 2 steps rearward from the first locking position.
3. Route the belt through the child restraint according to the child restraint system manufacturer's instructions, then insert the latch plate into the buckle.
4. Remove all slack of a lap belt by pulling the webbing through the belt's adjustment feature.
3-point type seat belt requires no length adjustment, remove all slack by using the locking clip.

5. If your child restraint system has a support leg, make sure that there is a support leg at the stable position on the floor.
6. Before putting the child in the restraint, push and pull the restraint in all directions to be sure it is secure. Do this before each use.

WARNING

- For some types of child restraint, the locking clip (A) should be used to help avoid personal injury during a collision or sudden manoeuvre. It must be fitted and used in accordance with the child restraint manufacturer's instructions. The locking clip must be removed when the child restraint is removed.

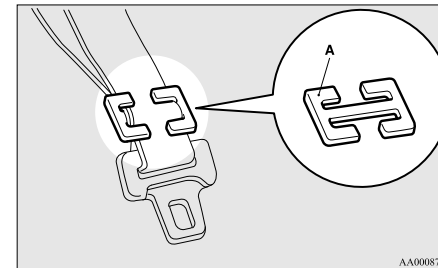

Seat belt inspection

E00406301850

Check the belts for cuts, worn or frayed webbing and for cracked or deformed metallic parts. Replace the belt assembly if it is defective.

WARNING

- We recommend you to have all seat belt assemblies including retractors and attaching hardware inspected after any collision. We recommend that seat belt assemblies in use during a collision be replaced unless the collision was minor and the belts show no damage and continue to operate properly.
- Do not attempt to repair or replace any part of the seat belt assemblies; we recommend you to have this work done by a MITSUBISHI MOTORS Authorized Service Point. Incorrect repair or replacement could reduce the effectiveness of the belts and could result in serious injury in the event of a collision.
- Once the pretensioner has been activated, it cannot be re-used. It must be replaced together with the retractor.

WARNING

- Do not insert any foreign objects (pieces of plastic, paper clips, buttons, etc.) in the buckle or retractor mechanism. In addition, do not modify, remove or install the seat belt. Otherwise, the seat belt may not be able to provide adequate protection in a collision or other situation.

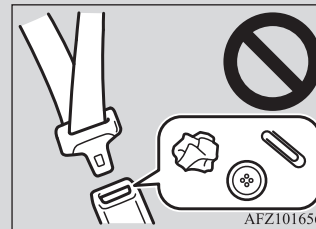

- A dirty belt should be cleaned with neutral detergent in warm water. After rinsing in water, let it dry in the shade. Do not attempt to bleach or re-dye the belts because this will affect their characteristics.

Supplemental restraint system (SRS)-airbag

E00407203645

The information for SRS airbags includes important information concerning the driver's and front passenger's airbags, the driver's knee airbag, the side airbags and the curtain airbags.

The SRS driver and front passenger airbags are designed to supplement the primary protection of the driver and front passenger side seat belt systems by providing those occupants with protection against head and chest injuries in certain moderate-to-severe frontal collisions.

The SRS driver's knee airbag is designed to supplement the primary protection of the driver's seat belt system. It can reduce the forward movement of the driver's lower legs and provide increased overall body protection in certain moderate-to-severe frontal collisions.

The SRS side airbags are designed to supplement properly worn seat belts and provide the driver and front passenger with protection against chest injuries in certain moderate-to-severe side impact collisions.

The SRS curtain airbags are designed to supplement properly worn seat belts and provide the driver and passenger with protection against head injuries in certain moderate-to-severe side impact collisions.

The SRS is NOT a substitute for the seat belts. To ensure the maximum protection during all types of collisions and accidents, all occupants, including the passengers as well as the driver, must wear their seat belts.

5

Supplemental restraint system (SRS)-airbag

How the Supplemental Restraint System works

E00407303460

The SRS includes the following components:

5

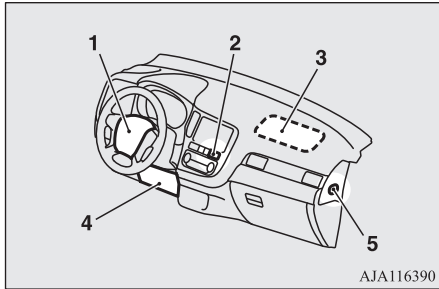

- 1- Airbag module (Driver)
- 2- Front passenger's airbag indicator
- 3- Airbag module (Passenger)
- 4- Driver's knee airbag module

- 5- Front passenger's airbag ON-OFF switch

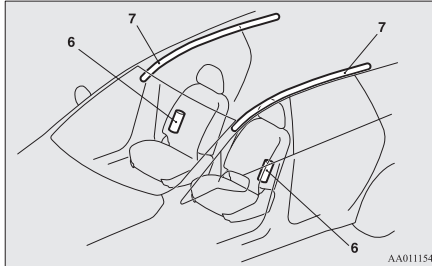

- 6- Side airbag modules
- 7- Curtain airbag modules

Only when the operation mode of the power switch is in ON, the airbags will operate.

The airbags deployment produces a sudden, loud noise, and releases some smoke and powder, but these conditions are not injurious, and do not indicate a fire in the vehicle. People with respiratory problems may feel some temporary irritation from chemicals used to produce the deployment; open the windows after airbag deployment, if safe to do so.

The airbags deflate very rapidly after deployment, so there is little danger of obscured vision.

CAUTION

- Airbags inflate at an extremely rapid speed. In certain situations, contact with inflating airbags can result in abrasions, bruises, light cuts, and the like.

WARNING

- **IT IS VERY IMPORTANT TO BE PROPERLY SEATED.**
A driver or front passenger too close to the steering wheel or instrument panel during airbag deployment can be killed or seriously injured.
Airbags inflate very fast, and with great force.
If the driver and front passenger are not properly seated and restrained, the airbags may not protect you properly, and could cause serious or fatal injuries when it inflates.
- Do not sit on the edge of the seat, or sit with your lower legs too close to the instrument panel, or lean head or chest close to the steering wheel or instrument panel. Do not put feet or legs on or against the instrument panel.
- Place all infants and small children in the rear seat and properly restrained using an appropriate child restraint system.
The rear seat is the safest place for infants and children.

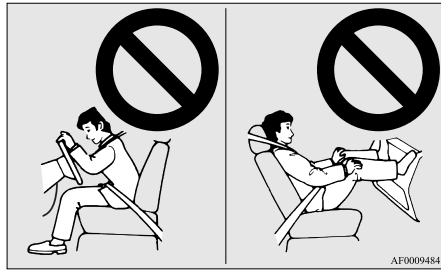

AF0009484

WARNING

- Older children should be seated in the rear seat, properly wearing the seat belt, with an appropriate booster seat if needed.

Caution for installing the child restraint on vehicles with a front passenger airbag

E00408802016

The label shown here is attached on vehicles with a front passenger airbag.

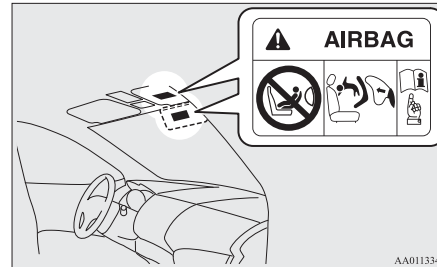

AA0113348

WARNING

- **Extreme Hazard!**
NEVER use a rearward facing child restraint on a seat protected by an ACTIVE AIRBAG in front of it, DEATH or SERIOUS INJURY to the CHILD can occur.

WARNING

- Infants and small children should never be unrestrained, stand up against the instrument panel or be held in your arms or on your lap. They could be seriously injured or killed in a collision, including when the airbag inflates. They should be properly seated in the rear seat in an appropriate child restraint system. See the "Child restraint" section of this owner's manual.

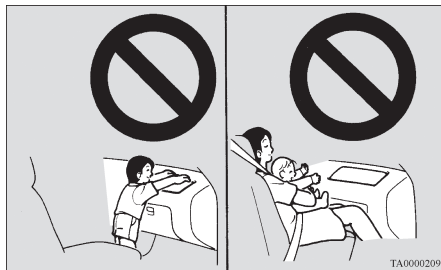

TA0000209

Front passenger's airbag ON-OFF switch

E00410100315

The front passenger's airbag ON-OFF switch can be used to disable the front passenger's airbag. If you have a child restraint system that cannot be fitted to any seat other than the front passenger seat, be sure to turn OFF the front passenger's airbag ON-OFF switch before using it.

5

(Refer to "To turn an airbag off" on page 5-28)

The front passenger's airbag ON-OFF switch is located as shown in the illustration.

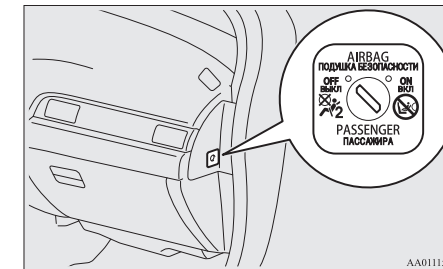

AA011559

Supplemental restraint system (SRS)-airbag

Front passenger's airbag indicator

E00410201528

The front passenger's airbag indicator is located in the instrument panel.

5

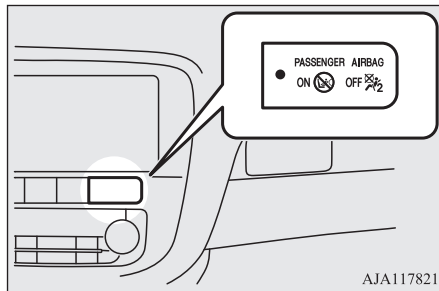

The both indicator normally comes on when the operation mode of the power switch is put in ON, and goes off a few seconds later. When the front passenger's airbag ON-OFF switch is turned OFF, the OFF indicator will stay on to show that the front passenger's airbag is not operational. When the front passenger's airbag ON-OFF switch is turned ON, the OFF indicator goes off, and the ON indicator comes on for approximately 1 minute to show that the front passenger's airbag is operational.

⚠ WARNING

- Do not fit any accessory that makes the indication lamp impossible to see, and do not cover the indication lamp with a sticker. You would not be able to verify the status of the passenger airbag system.

To turn an airbag off

E00412301259

⚠ WARNING

- To reduce risk of serious or fatal injury:
 - Always put the operation mode of the power switch in OFF, before operating the front passenger's airbag ON-OFF switch. Failure to do so could adversely affect the airbag performance.
 - Wait at least 60 seconds to operate the front passenger's airbag ON-OFF switch after putting the operation mode in OFF.
The SRS airbag system is designed to retain enough voltage to deploy the airbag.
 - Always remove the key from the front passenger's airbag ON-OFF switch after operating that switch. Failure to do so could lead to improper position of the front passenger's airbag ON-OFF switch.

⚠ WARNING

- Do not turn OFF the front passenger's airbag ON-OFF switch except when a child restraint system is fitted to the front passenger seat.
- If the OFF indicator does not come on when the front passenger's airbag ON-OFF switch is turned OFF, do not fit a child restraint system to the front passenger seat. We recommend you to have the system inspected by a MITSUBISHI MOTORS Authorized Service Point.
- If the OFF indicator remains on when the front passenger's airbag ON-OFF switch is turned ON, do not allow anyone to sit on the front passenger seat. We recommend you to have the system inspected by a MITSUBISHI MOTORS Authorized Service Point.

To turn an airbag off, follow these steps:

1. Remove the emergency key from the keyless operation key.
Refer to "Emergency key" on page 4-14.
2. Insert the emergency key into the front passenger's airbag ON-OFF switch, and turn it to the "OFF" position.
3. Remove the emergency key from the front passenger's airbag ON-OFF switch.

Supplemental restraint system (SRS)-airbag

- Put the operation mode of the power switch in ON. The front passenger's airbag OFF indication lamp will stay on.

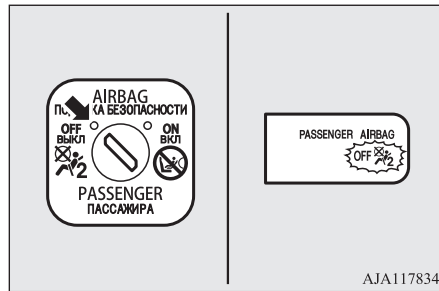

The front passenger's airbag is now deactivated and will not deploy until switched on again.

Driver's and front passenger's airbag system

E00407400792

The driver's airbag is located under the padded cover in the middle of the steering wheel. The front passenger's airbag is contained in the instrument panel above the glove box.

The driver's airbag and the front passenger's airbag are designed to inflate at the same time even if the passenger seat is not occupied.

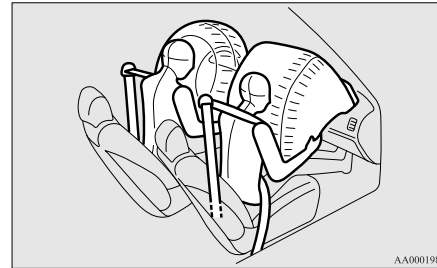

Driver's knee airbag system

E00412401104

The driver's knee airbag is located under the steering wheel. The driver's knee airbag is designed to deploy at the same time as the driver's front airbag.



OGGE19E1

Deployment of front airbags and driver's knee airbag

E00407502700

The front airbags and driver's knee airbag ARE DESIGNED TO DEPLOY when...

The front airbags and driver's knee airbag are designed to deploy when the vehicle suffers a moderate-to-severe frontal impact. The typical condition is shown in the illustration.

5

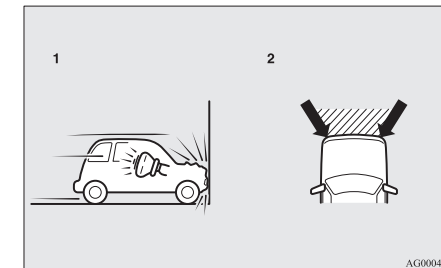

- Head-on collision with a solid wall at a speed of approximately 25 km/h (16 mph) or higher
- Moderate-to-severe frontal impact with in the shaded area between the arrows

Seats and seat belts 5-29

Supplemental restraint system (SRS)-airbag

5

The front airbags and driver's knee airbag will deploy if the severity of the impact is above the designed threshold level, comparable to a collision at approximately 25 km/h (16 mph) when impacting straight into a solid wall that does not move or deform. If the severity of the impact is below the above threshold level, the front airbags and driver's knee airbag may not deploy. However, this threshold speed will be considerably higher if the vehicle strikes an object that absorbs the impact by either deforming or moving (for example, another stationary vehicle, pole or a guard rail).

Because frontal collisions can easily move you out of position, it is important to always properly wear your seat belts. Your seat belts will help keep you a safe distance from the steering wheel and instrument panel during the initial stages of airbag deployment. The initial stage of airbag inflation is the most forceful, and can possibly cause serious or fatal injuries. Moreover, the seat belts in your vehicle are your primary means of protection in a collision. The SRS airbags are designed to provide additional protection. Therefore, for your safety and the safety of all occupants, be sure to always properly wear your seat belts.

The front airbags and driver's knee airbag MAY NOT DEPLOY when...

With certain types of frontal collisions, the vehicle's body structure is designed to absorb the shock to help protect the occupants from harm. (The vehicle body's front area may deform significantly as it absorbs the impact.) Under such circumstances, the front airbags and driver's knee airbag may not deploy irrespective of the deformation and damage to the vehicle body.

Examples of some typical conditions are shown in the illustration.

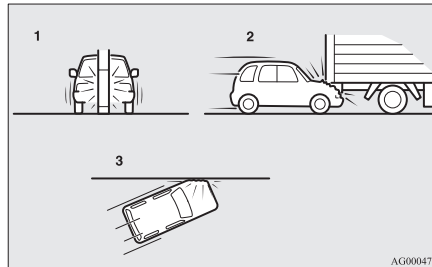

- 1- Collision with a utility pole, tree or other narrow object
- 2- Vehicle slides under the rear body of a truck
- 3- Oblique frontal impacts

Because the front airbags and driver's knee airbag do not protect the occupant in all types of frontal collisions, be sure to always properly wear your seat belts.

The front airbags and driver's knee airbag ARE NOT DESIGNED TO DEPLOY when...

The front airbags and driver's knee airbag are not designed to deploy in conditions where they cannot typically provide protection to the occupant.

Such conditions are shown in the illustration.

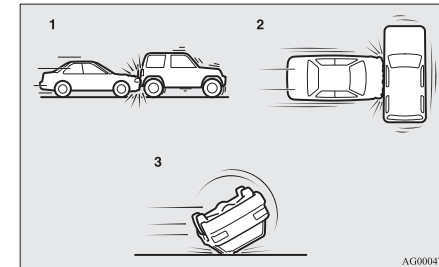

- 1- Rear end collisions
- 2- Side collisions
- 3- Vehicle rolls onto its side or roof

Because the front airbags and driver's knee airbag do not protect the occupant in all types of collisions, be sure to always properly wear your seat belts.

The front airbags and driver's knee airbag MAY DEPLOY when...

The front airbags and driver's knee airbag may deploy if the bottom of the vehicle suffers a moderate-to-severe impact (undercarriage damage).

Examples of some typical conditions are shown in the illustration.

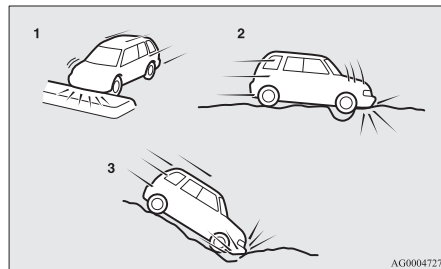

- 1- Collision with an elevated median/island or kerb
- 2- Vehicle travels over a deep hole/pothole
- 3- Vehicle drives down a steep slope and hits the ground

Because the front airbags and driver's knee airbag may deploy in certain types of unexpected impacts as shown in the illustration that can easily move you out of position, it is important to always properly wear your seat belts. Your seat belts will help keep you a safe distance from the steering wheel and instrument panel during the initial stages of airbag deployment. The initial stage of airbag inflation is the most forceful and can possibly cause serious or fatal injuries if you contact it at this stage.

WARNING

- Do not attach anything to the steering wheel's padded cover, such as badges or accessories. It might strike and injure an occupant if the airbag inflates.
- Do not set anything on, or attach anything to, the instrument panel above the glove box. It might strike and injure an occupant if the airbag inflates.

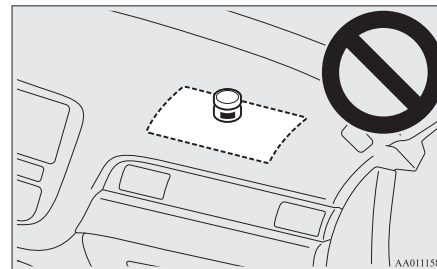

OGGE19E1

WARNING

- Do not attach accessories to, or put them in front of, the windscreen. These objects could restrict the airbag inflation, or strike and injure an occupant if the airbags inflate.
- Do not attach accessories to the lower portion of the driver's side instrument panel. Such objects could prevent the driver's knee airbag from inflating normally or could be propelled and cause serious injury if the airbag inflates.

5

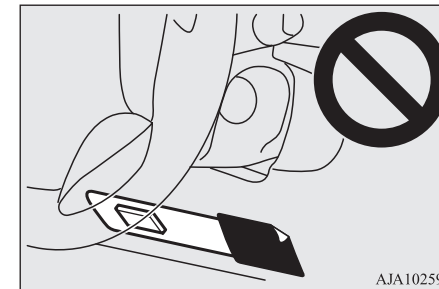

AJA102591

WARNING

- Do not put packages, pets or other objects between the airbags and the driver or front passenger. It could affect airbag performance, or could cause injury when the airbag inflates.

Supplemental restraint system (SRS)-airbag

⚠ WARNING

- Right after the airbag inflation, several airbag system components will be hot. Do not touch these components. There is a danger of being burnt.
- The airbag system is designed to work only once. Once the airbags have deployed, they will not work again. They must promptly be replaced, and we recommend you to have the entire airbag system inspected by a MITSUBISHI MOTORS Authorized Service Point.

5

Side airbag system

E00407600619

The side airbags (A) are contained in the driver and front passenger seatbacks. The side airbag is designed to inflate only on the side of the vehicle that is impacted, even with no passenger in the front seat.

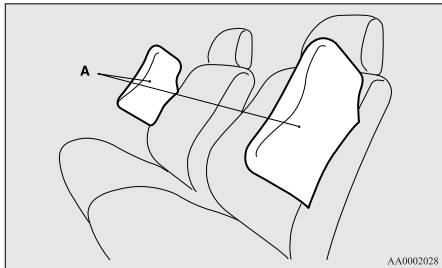

The label shown here is attached to the seatbacks with a side airbag.

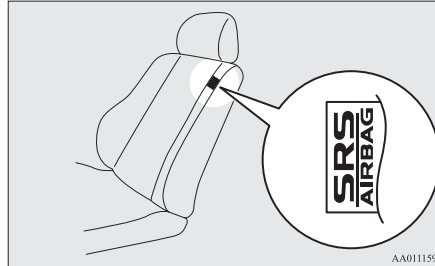

Curtain airbag system

E00409101686

The curtain airbags are contained in the front pillars and roof side rail. The curtain airbag is designed to inflate only on the side of the vehicle that is impacted, even with no passenger in the front seat or rear seat.

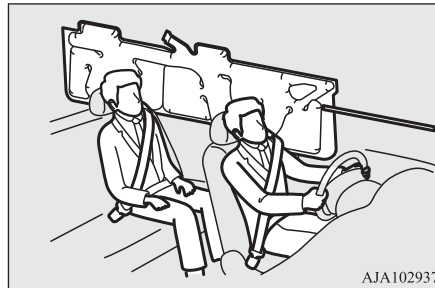

Deployment of side airbags and curtain airbags

E00407702731

The side airbags and curtain airbags ARE DESIGNED TO DEPLOY when...

The side airbags and curtain airbags are designed to deploy when the vehicle suffers a moderate-to-severe side impact to the middle of the passenger compartment. The typical condition is shown in the illustration.

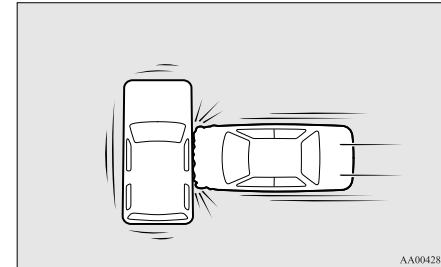

The seat belts in your vehicle are your primary means of protection in a collision. The SRS side airbags and curtain airbags are designed to provide additional protection. Therefore, for your safety and the safety of all occupants, be sure to always properly wear your seat belts.

The side airbags and curtain airbags MAY NOT DEPLOY when...

With certain types of side collisions, the vehicle's body structure is designed to absorb the shock to help protect the occupants from harm. (The vehicle body's side area may deform significantly as it absorbs the impact.) Under such circumstances, the side airbags and curtain airbags may not deploy irrespective of the deformation and damage to the vehicle body. Examples of some typical conditions are shown in the illustration.

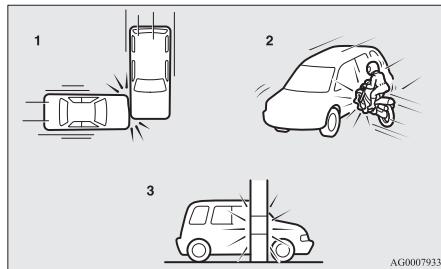

- 1- Side impacts in an area away from the passenger compartment
- 2- Motorcycle or other similar small vehicle collides with the side of vehicle

- 3- Collision with a utility pole, tree or other narrow object

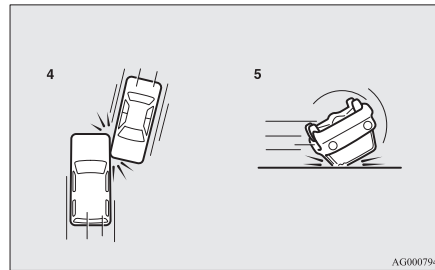

- 4- Oblique side impacts
- 5- Vehicle rolls onto its side or roof

Because the side airbags and curtain airbags do not protect the occupant in all types of side collisions, be sure to always properly wear your seat belts.

The side airbags and curtain airbags ARE NOT DESIGNED TO DEPLOY when...

The side airbags and curtain airbags are not designed to deploy in conditions where they cannot usually provide protection to the occupant. Typical conditions are shown in the illustration.

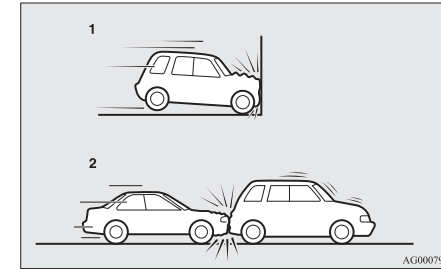

- 1- Head-on collisions
- 2- Rear end collisions

5

Because the side airbags and curtain airbags do not protect the occupant in all types of collisions, be sure to always properly wear your seat belts.

⚠ WARNING

- The side airbags and curtain airbags are designed to supplement the driver and passenger seat belts in certain side impacts. Seat belts should always be worn properly, and the driver and passenger should sit well back and upright without leaning against the window or door.

Supplemental restraint system (SRS)-airbag

5

⚠ WARNING

- The side airbag and curtain airbag inflate with great force. The driver and passenger should not put their arms out of the window, and should not lean against the door, in order to reduce the risk of serious or possible fatal injury from the deploying side airbag and curtain airbag.



⚠ WARNING

- Do not allow any rear seat occupant to hold onto the seatback of either front seat, in order to reduce risk of injury from the deploying side airbag. Special care should be taken with children.
- Do not place any objects near or in front of the seatback of either front seat. They could interfere with proper side airbag inflation, and also could cause injury if thrown free by side airbag deployment.

⚠ WARNING

- Do not place stickers, labels or additional trim on the seatback of either front seat. They could interfere with proper side airbag inflation.
- Do not install seat covers on seats with side airbags. Do not re-cover seats that have side airbags. This could interfere with proper side airbag inflation.
- Do not attach a microphone (A) or any other device or object around the part where the curtain airbags (B) activate such as on the windscreen, side door glass, front and rear pillars and roof side or assist grips. When the curtain airbags inflate, the microphone or other device or object will be hurled with great force or the curtain airbags may not activate correctly, resulting in death or serious injury.

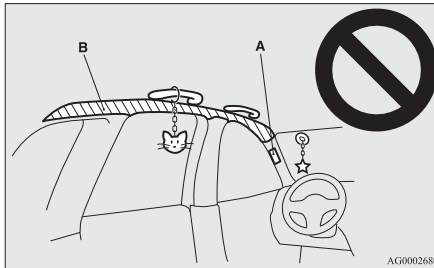

⚠ WARNING

- Do not put a hanger or any heavy or pointed object on the coat hook. If the curtain airbag was activated, any such item could be propelled away with great force and could prevent the curtain airbag from inflating correctly. Hang clothes directly on the coat hook (without using a hanger). Make sure there are no heavy or sharp objects in the pockets of clothes that you hang on the coat hook.
- Do not allow a child to lean against or close to the front door even if the child is seated in a child restraint system. The child's head should also not lean against or be close to the area where the side airbag and curtain airbag are located. It is dangerous if the side airbag and curtain airbag inflate. Failure to follow all of these instructions could lead to serious or fatal injury to the child.
- We recommend work around and on the side airbags and curtain airbags system to be done by a MITSUBISHI MOTORS Authorized Service Point.

SRS warning lamp/display

E00407803191

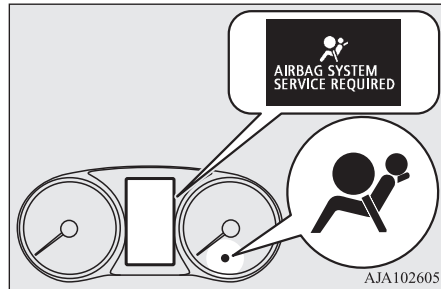

There is a Supplemental Restraint System (“SRS”) warning lamp on the instrument panel. The system checks itself every time the operation mode of the power switch is put in ON. The SRS warning lamp will come on for several seconds and then go out. This is normal and means the system is working properly.

If there is a problem involving one or more of the SRS components, the warning lamp will come on and stay on. At the same time, the warning display will appear on the information screen in the multi information display. The SRS warning lamp/display is shared by the SRS airbag and the seat belt pretensioner system.

⚠ WARNING

● If any of the following conditions occur, there may be a problem with the SRS airbags and/or seat belt pretensioners, and they may not function properly in a collision or may suddenly activate without a collision:

- Even when the operation mode is in ON, the SRS warning lamp does not come on or it remains on.
- The SRS warning lamp and/or the warning display comes on while driving.

The SRS airbags and seat belt pretensioners are designed to help reduce the risk of serious injury or death in certain collisions. If either of the above conditions occurs, immediately have your vehicle checked by a MITSUBISHI MOTORS Authorized Service Point.

SRS servicing

E00407902658

⚠ WARNING

● We recommend any maintenance performed on or near the components of the SRS to be performed by a MITSUBISHI MOTORS Authorized Service Point. Improper work on the SRS components or wiring could result in inadvertent deployment of the airbags, or could render the SRS inoperative; either situation could result in serious injury.

⚠ WARNING

- Do not modify your steering wheel, seat belt retractor or any other SRS components. For example, replacement of the steering wheel, or modifications to the front bumper or body structure can adversely affect SRS performance and lead to possible injury.
- If your vehicle has sustained any damage, we recommend you to have the SRS inspected to ensure it is in proper working order.
- Do not modify your front seats, centre pillar and centre console. It can adversely affect SRS performance and lead to possible injury.
- If you found any tear, scratch, crack or damage to the portion where the airbag is stored, you should have the SRS inspected by a MITSUBISHI MOTORS Authorized Service Point.

5

📖 NOTE

- If your vehicle has to be scrapped, do this in line with local legislation and contact a MITSUBISHI MOTORS Authorized Service Point to safely dismantle the airbag system.

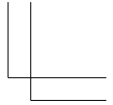
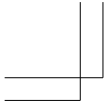

Handwriting practice area consisting of 12 horizontal dashed lines.

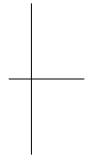
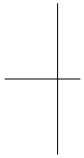

OGGE19E1

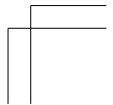
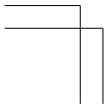

Instruments and controls

Instruments.....	6-02
Multi information display.....	6-04
Indication lamp, warning lamp, and information screen display list.....	6-24
Indication lamps.....	6-54
Warning lamps.....	6-55
Information screen display.....	6-58
Combination headlamps and dipper switch.....	6-59
Headlamp levelling.....	6-66
Turn-signal lever.....	6-67
Hazard warning flasher switch.....	6-67
ECO mode switch.....	6-68
Fog lamp switch.....	6-68
Wiper and washer switch.....	6-69
Wiper de-icer switch*.....	6-74
Rear window demister switch.....	6-74
Heated windscreen switch*.....	6-75
Heated steering wheel switch*.....	6-76
Horn switch.....	6-77

Instruments

E00500103079

6

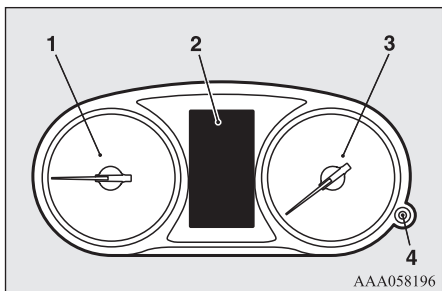

AAA058196

- 1- Energy usage indicator → p. 6-02
- 2- Multi information display → p. 6-04
Information screen display list
→ p. 6-25
- 3- Speedometer (km/h or mph + km/h)
- 4- Rheostat illumination button → p. 6-03

Energy usage indicator

E00529601037

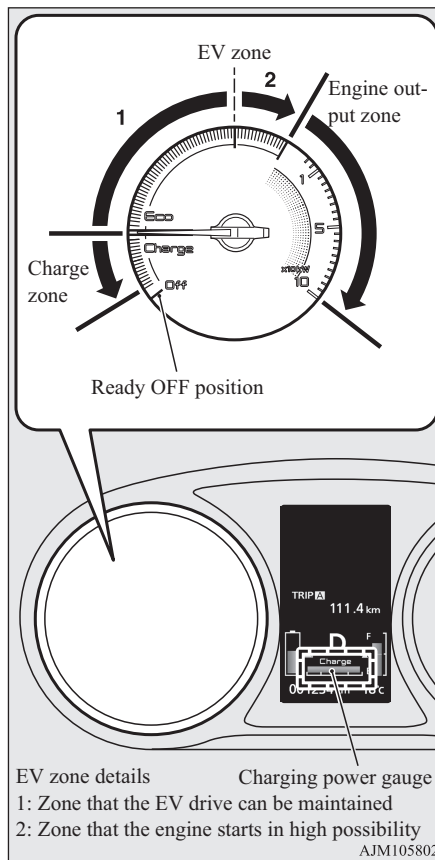

EV zone details Charging power gauge
 1: Zone that the EV drive can be maintained
 2: Zone that the engine starts in high possibility

AJM105802

OGGE19E1

Ready OFF position

Indicates that the vehicle cannot run (READY OFF).

When the vehicle is ready for running, the needle of the energy usage indicator moves to the horizontal position.

EV zone

The EV zone shows the output during EV drive (driving with the engine stopped).

The EV zone is covered by the numbers 1 and 2 in the illustration.

Zone 1 shows the state that the EV drive can be maintained, while zone 2 shows the state that the engine starts in high possibility. As the motor output increases, the movement range of the needle of the energy usage indicator increases.

In addition, the needle of the energy usage indicator indicates the horizontal position when the engine is stopped or when there is no electric energy generated by the motor output and the regenerative brake.

NOTE

- Depending on the state of the vehicle (such as during heating of the air conditioner), the engine may start even if the needle of the energy usage indicator is indicated before zone 2 (the zone that the engine starts in high possibility).
- Even when the EV priority mode is selected and the engine does not start, the needle of the energy usage indicator may indicate zone 2 (the zone that the engine starts in high possibility).
- When the EV priority mode is selected, even if the needle of the energy usage indicator enters zone 2, it will not start the engine unless it is over the specified point by pressing the accelerator pedal.
- Depending on the vehicle condition, the movement of the needle of the energy usage indicator may be different or fluctuate.
- Economical driving can be achieved by operating in such state that the swing of the needle is small within zone 1.

Charge zone

Indicates the charging power generated by the regenerative brake.
 The more the needle moves, the more electric energy is charged.
 The needle of the energy usage indicator may not enter the charge zone when the drive battery is close to full charge.

Also, if the needle of the energy usage indicator indicates the engine output zone, the needle does not indicate the charge zone even when there is charging of the electrical energy by regenerative braking.

NOTE

- With the charging power gauge of the multi information display, you can check the charging power of electric energy generated by regenerative braking even while the engine is operating.
- Both the display of the charge zone by the energy usage indicator needle and the display of the charging power gauge in the multi information display indicate the charging power of electric energy by regenerative braking.

Engine output zone

Indicates the instantaneous output (kW) of the engine.

Meter illumination control

E00531301174

Each time you press the rheostat illumination button, there is a sound and the brightness of the instruments changes.

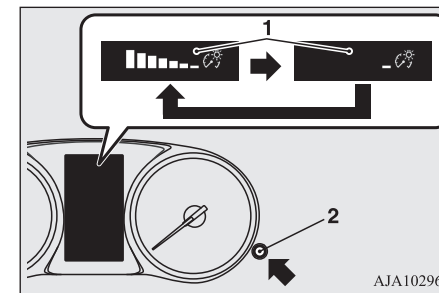

- 1- Brightness level
- 2- Rheostat illumination button

6

NOTE

- You can adjust to 8 different levels respectively for when the position lamps are illuminated and when they are not.
- When the lamp switch is in a position other than the "OFF" position, the meter illumination switches automatically to the adjusted brightness, depending on the brightness outside the vehicle.

Multi information display

NOTE

- The brightness level of the instruments is stored when the operation mode of the power switch is put in OFF.
- If you press and hold the button for about 2 seconds or more when the position lamps are illuminated, the brightness level changes to the maximum level. Pressing and holding the button for about 2 seconds or more again returns the brightness level to the previous level.

On vehicles equipped with the MITSUBISHI Multi-Communication System (MMCS), the map screen colour of MITSUBISHI Multi-Communication System (MMCS) may not be switched to night-time setting when the meter illumination brightness level is at the maximum.

6

Multi information display

E00519903158



Always stop the vehicle in a safe place before operating.

The following information is included on the multi information display: warnings, odometer, tripmeter, average fuel consumption, EV cruising range, total cruising range, EVHV driving rate, energy flow, etc.

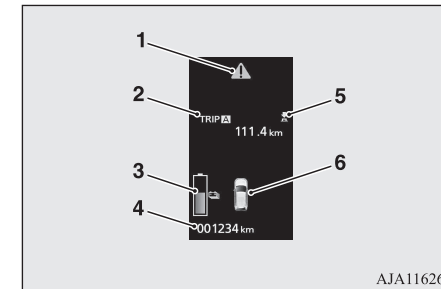
[When the operation mode of the power switch is OFF]



AJA116260

- 1-  mark display screen → p. 6-11
- 2- Information screen → p. 6-07
Interrupt display screen → p. 6-10
- 3- Drive battery level display screen → p. 6-11
- 4- Odometer → p. 6-13
- 5- “” or “” mark indicator → p. 6-10

Multi information display

- 6- Door ajar warning display screen [When the operation mode of the power switch is ON]
→ p. 6-11

NOTE

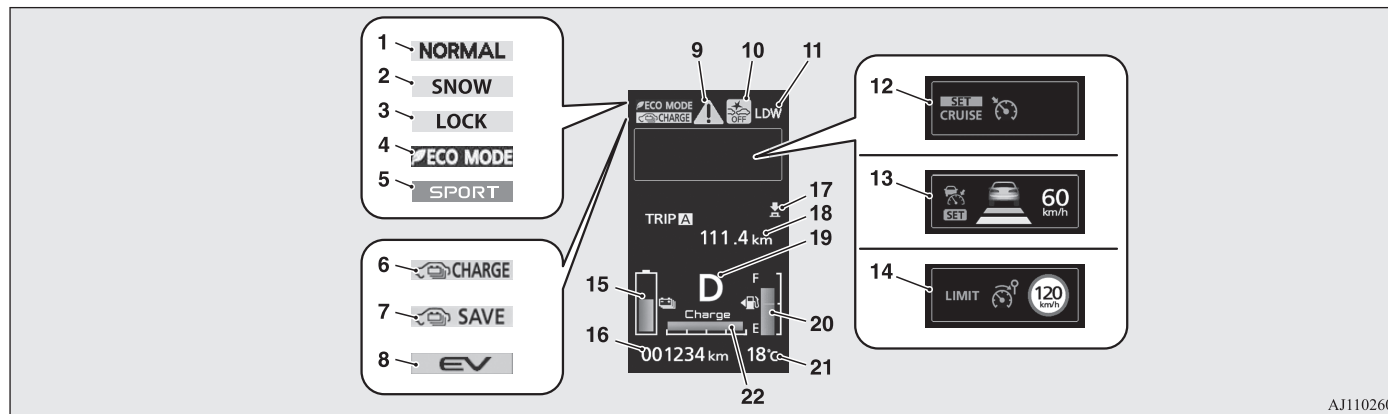

- The drive battery level display screen appears when any of the doors or the tailgate is opened during charging.



6

- | | | |
|--|--|--|
| 1- NORMAL mode indicator display | 6- Battery charge mode display screen
→ p. 7-29 | 10- Forward Collision Mitigation System (FCM) OFF display screen* → p. 7-67 |
| 2- SNOW mode indicator display | 7- Battery save mode display screen
→ p. 7-29 | Ultrasonic misacceleration Mitigation System (UMS) OFF display screen* → p. 7-77 |
| 3- LOCK mode indicator display
S-AWC (Super All Wheel Control)
→ p. 7-20 | 8- EV priority mode display screen
→ p. 7-25 | 11- Lane Departure Warning (LDW) display screen* → p. 7-88 |
| 4- ECO mode indicator display
ECO mode switch → p. 6-68 | 9- mark display screen → p. 6-11 | 12- Cruise control display screen* → p. 7-45 |
| 5- SPORT mode indicator display
SPORT mode switch → p. 7-31 | | |

Multi information display

- 13- Adaptive Cruise Control System (ACC) display screen* → p. 7-55
- 14- Speed limiter display screen* → p. 7-50
- 15- Drive battery level display screen → p. 6-11
- 16- Odometer → p. 6-13
- 17- “” or “” mark indicator → p. 6-10
- 18- Information screen → p. 6-09
- 19- Select position indicator → p. 7-17
- 20- Fuel remaining display screen → p. 6-11
- 21- Outside temperature display screen → p. 6-13
- 22- Charging power gauge → p. 6-12

6

It is also possible to change elements such as the language and units used on the multi information display by operating the multi information display switch.

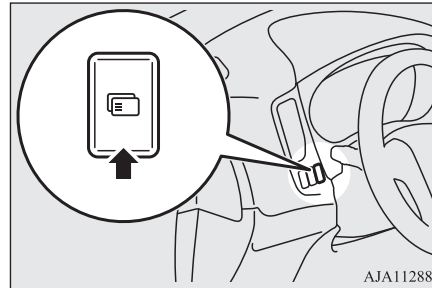

Multi information display switch

E00520001911

Each time the multi information display switch is operated, the buzzer sounds and the multi information display changes between information such as warnings, tripmeter, average fuel consumption, EV cruising range, total cruising range, EVHV driving rate, energy flow, etc.

Information screen (when the operation mode is OFF)

E00520201968

Each time you lightly press the multi information display switch, the display screen switches in the following order.

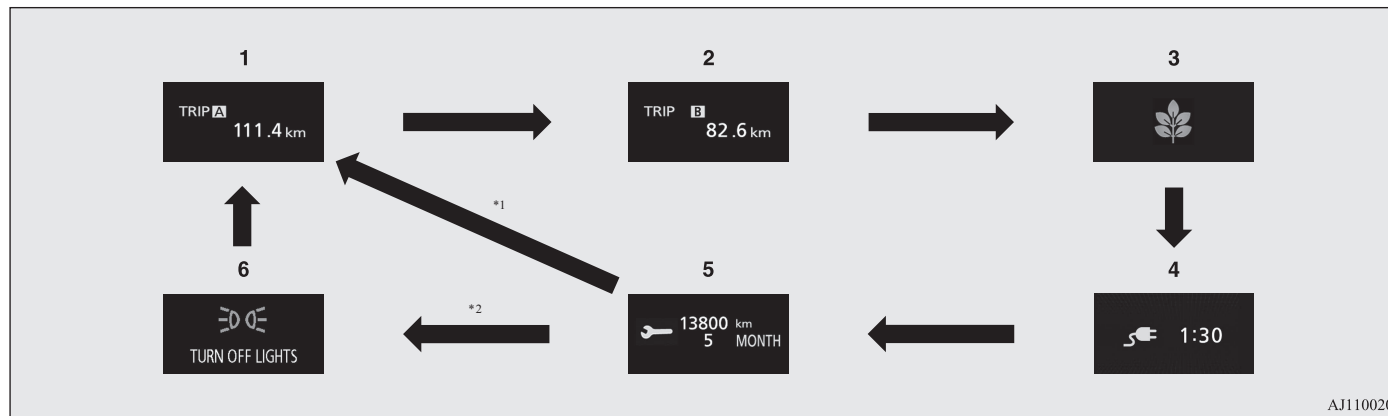

*1: When there is no warning display

*2: When there is a warning display

1- Tripmeter **A** → p. 6-13

2- Tripmeter **B** → p. 6-13

3- ECO score display → p. 6-17

4- Predicted charging time → p. 3-10, 3-17

5- Service reminder → p. 6-13

6- Redisplay of a warning display screen
→ p. 6-10

Multi information display

Information screen (when the operation mode is changed from OFF to ON)

E00520702351

When the operation mode is put in ON, the display screen switches in the following order.

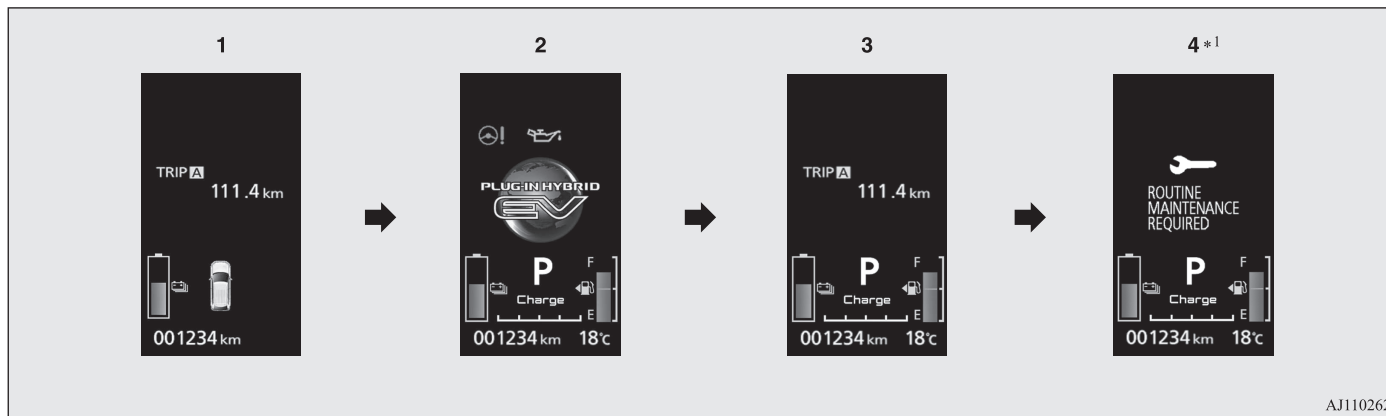

*1: When the inspection time has arrived

1- Screen when the operation mode is OFF

2- System check screen → p. 6-15

3- Screen when the operation mode is ON

4- Service reminder → p. 6-13

Information screen (when the operation mode is ON)

E00521102192

Each time you lightly press the multi information display switch, the display screen switches in the following order.

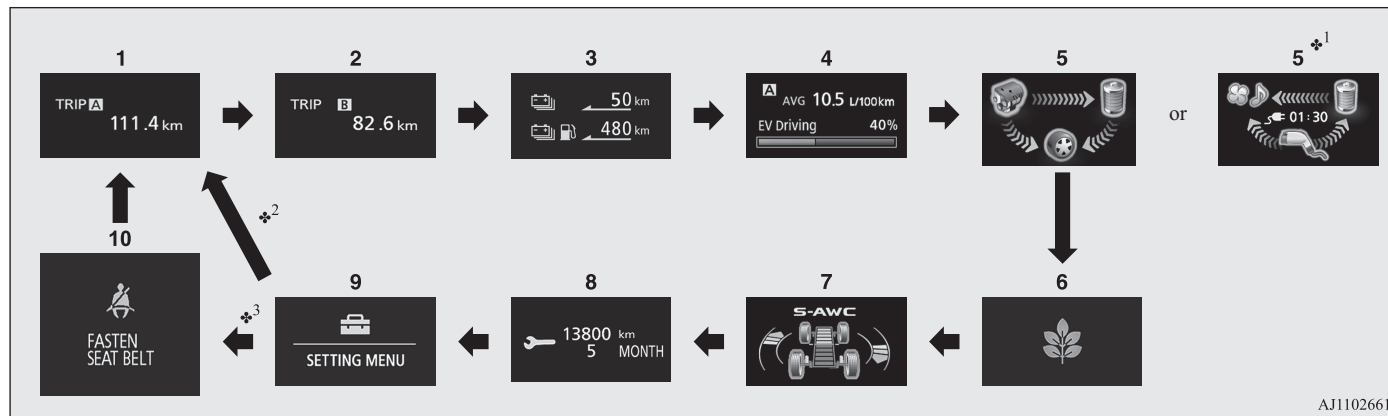

*1: When the vehicle is charged

*2: When there is no warning display

*3: When there is a warning display

1- Tripmeter **A** → p. 6-13

2- Tripmeter **B** → p. 6-13

3- EV cruising range display/Total cruising range display → p. 6-15

4- Average fuel consumption display → p. 6-16

EVHV driving rate display → p. 6-16

5- Energy flow display → p. 6-16

or

Energy flow display during charging → p. 3-26

6- ECO score display → p. 6-17

7- S-AWC (Super-All Wheel Control) operation display → p. 7-22

8- Service reminder → p. 6-13

9- Function setting screen → p. 6-17

10- Redisplay of a warning display screen → p. 6-10

Multi information display

NOTE

- While driving, the service reminder is not displayed even if you operate the multi information display switch. Always stop the vehicle in a safe place before operating.
- While driving, the function setting screen is not displayed even if you operate the multi information display switch. Before operation, park the vehicle in a safe place, firmly apply the parking brake, press the electrical parking switch, and shift to “P” (PARK) position. Refer to “Changing the function settings” on page 6-17.
- When there is information to be announced, such as a system fault, the buzzer sounds and the screen display is switched. Refer to “Interrupt display screen” on page 6-10.

6

Interrupt display screen

E00522002084

Warning display

When there is information to be announced, such as a system fault, the buzzer sounds and the information screen is switched to the warning display screen.

Refer to the warning list and take the necessary measures.

Refer to “Warning display list” on page 6-26.

When the cause of the warning display is eliminated, the warning display goes out automatically.

To return to the screen displayed before the warning display

Even if the cause of the warning display is not eliminated, you can return to the screen that was displayed before the warning display.

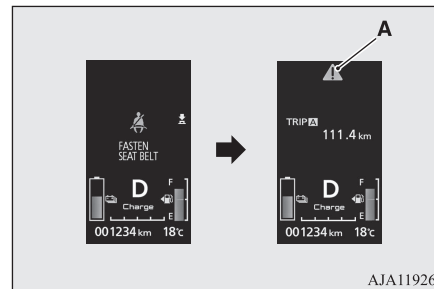

If you press the multi information display switch, the display screen switches to the screen that was displayed before the warning display and the  mark (A) is displayed.



AJA119261

OGGE19E1

If you want to switch the display

Warning display screens with a  or  mark displayed in the upper right of the screen can be switched. If you want to switch the display, press the multi information display switch as follows.

: Press lightly.

: Press for approximately 2 seconds or more.

Redisplay of a warning display screen

When the  mark is displayed, if you lightly press the multi information display switch a few times, the warning display screen you switched from is redisplayed.

Other interrupt displays

The operation status of each system is displayed on the information screen.

Refer to the appropriate page in the warning display list for further details.
Refer to “Other interrupt displays” on page 6-48.

A mark display screen

E00533901028

This is displayed when you press the multi information display switch and return from the warning display screen to the previous screen.

This mark is also displayed if there is another warning other than the one displayed.

When the cause of the warning display is eliminated, the **A** mark goes out automatically.

NOTE

- When the **A** mark is displayed, the warning display screen can be redisplayed on the information screen.
Refer to “Information screen (when the operation mode is OFF)” on page 6-07.
Refer to “Information screen (when the operation mode is ON)” on page 6-09.

Door ajar warning display screen

E00522601979



If any of the doors or the tailgate is not completely closed, this displays the open door or tailgate.

When the operation mode of the power switch is ON, if the vehicle speed exceeds approximately 8 km/h (5 mph) while a door is ajar, a buzzer sounds 4 times. This notifies the driver that a door is ajar.

CAUTION

- Before moving your vehicle, check that the warning display does not appear.

Drive battery level display screen

E00537700027



Indicates the remaining power in the drive battery.

6

Fuel remaining display screen

E00522201542

This displays the amount of fuel remaining.

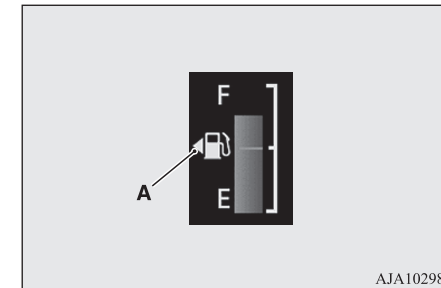

AJA102982

F- Full
E- Empty

Multi information display

NOTE

- It may take several seconds to stabilise the display after refilling the tank.
- If fuel is added with the operation mode of the power switch is in ON, the fuel gauge may incorrectly indicate the fuel level.
- The arrow (A) indicates that the fuel tank filler is located on the left side of the body.

6

Fuel remaining warning display

E00522402495

When the fuel is reduced to approximately 7 litres, the information screen switches to the interrupt display of the fuel remaining warning display, and the “” mark (B) on the fuel remaining display flashes slowly (approximately once per second). After a few seconds, the information screen returns from the fuel remaining warning display to the previous screen.

If the remaining fuel level is reduced further, the information screen switches to the fuel remaining warning display and the “” mark (B) on the fuel remaining display flashes quickly (approximately twice per second).

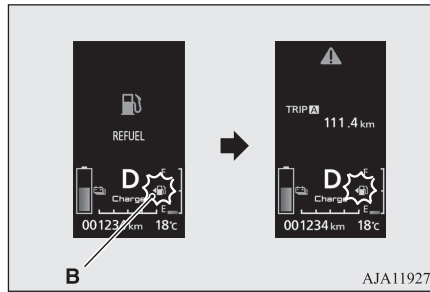

CAUTION

- If the warning display appears, refuel as soon as possible. If the vehicle runs out of fuel, the engine will not start even in a situation need to be generated electricity, the following conditions will occur.
 - The driving performance falls (since only the electrical power stored in the drive battery can be used for the driving).
 - The heating performance cannot be available (except for vehicles with an electric heater).
 - The effectiveness of the heater is insufficient (vehicles with electric heater).

CAUTION

- The catalytic converter may be damaged due to excessive high temperature.

NOTE

- On inclines or curves, the display may be incorrect due to the movement of fuel in the tank.
- The battery save mode or battery charge mode are cancelled or may not be activated even if the battery save mode switch or the battery charge mode is selected, depending on the remaining quantity of the drive battery or the control condition of the system.

Charging power gauge

E00538400021

The charging power gauge shows momentary charging power of the electric energy that is generated by regenerative braking.

Charging power with regenerative brake

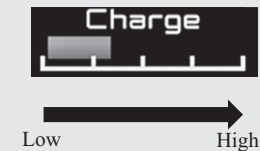

AJA119506

Multi information display

NOTE

- The charging power gauge does not include the electric power generation by the engine operation.
- The charging power gauge does not indicate the running condition of  CHARGE battery charge.
- The movement of the gauge decreases as the drive battery level is nearly full.

Outside temperature display screen

E00522101509



This shows the temperature outside the vehicle.

NOTE

- The display setting can be changed to the preferred units (°C or °F). Refer to “Changing the function settings” on page 6-17.
- Depending on factors such as the driving conditions, the displayed temperature may vary from the actual outside temperature.

Odometer

E0052780083

The odometer indicates the distance travelled.

Tripmeter

E00527901078

The tripmeter indicates the distance travelled between two points.

Example usage of tripmeter **A** and tripmeter **B**

It is possible to measure two currently travelled distances, from home using tripmeter **A** and from a particular point on the way using tripmeter **B**.

To reset the tripmeter

To return the display to 0, hold down the multi-information display switch for about 2 seconds or more. Only the currently displayed value will be reset.

Example

If tripmeter **A** is displayed, only tripmeter **A** will be reset.

NOTE

- When disconnecting the auxiliary battery terminal, the memory of tripmeter **A** and **B** are cleared, and the display returns to “0”.

Service reminder

E00522502021

Displays the approximate time until the next periodic inspection recommended by MITSUBISHI MOTORS. “---” is displayed when the inspection time has arrived.

NOTE

- Depending on the vehicle specifications, the displayed time may differ from the next periodic inspection time recommended by MITSUBISHI MOTORS. In addition, the display settings for the next periodic inspection time can be modified. To modify the display settings, have it adjusted at a MITSUBISHI MOTORS Authorized Service Point. For more details, consult a MITSUBISHI MOTORS Authorized Service Point.

6

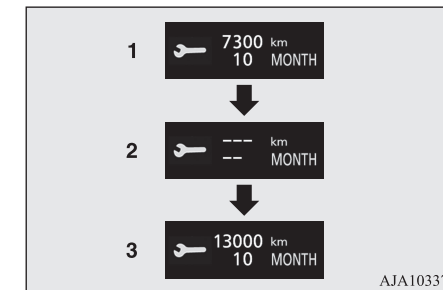

1. Displays the time until the next periodic inspection.

Instruments and controls 6-13

OGGE19E1

Multi information display

NOTE

- The distance is shown in units of 100 km (100 miles). The time is shown in units of months.

2. This informs you that a periodic inspection is due. We recommend you to consult a MITSUBISHI MOTORS Authorized Service Point.

At that time, when the ignition switch is switched from “OFF” to “ON”, the warning display is displayed for a few seconds on the information screen.



3. After your vehicle is inspected at a MITSUBISHI MOTORS Authorized Service Point, it displays the time until the next periodic inspection.

To reset

The “---” display can be reset while the ignition switch or the operation mode is in OFF.

When the display is reset, the time until the next periodic inspection is displayed and the warning display is no longer displayed when the ignition switch is switched from “OFF” to “ON”.

1. When you lightly press the multi information display switch a few times, the information display switches to the service reminder display screen.

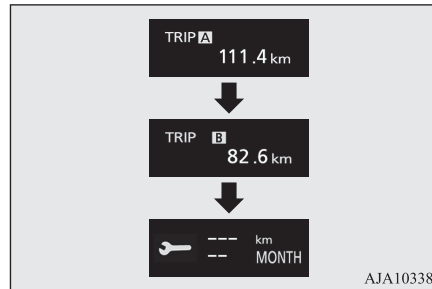

2. Press and hold the multi information display switch for about 2 seconds or more to display “” and make it flash. (If there is no operation for about 10 seconds with flashing, the display returns to the previous screen.)

3. Lightly press the multi information display switch while the icon is flashing to change the display from “---” to “CLEAR”. After this, the time until the next periodic inspection will be displayed.

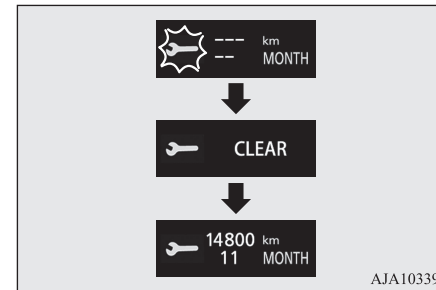

CAUTION

- The customer is responsible for making sure that periodic inspection and maintenance are performed. Inspections and maintenance must be performed to prevent accidents and malfunctions.

NOTE

- “---” display cannot be reset when the operation mode is in ON.

NOTE

- When “---” is displayed, after a certain distance and a certain period of time, the display is reset and the time until the next periodic inspection is displayed.
- If you accidentally reset the display, we recommend you to consult a MITSUBISHI MOTORS Authorized Service Point.

System check screen

E00531001070

When the operation mode is put in ON, the system check screen is displayed for about 4 seconds. If there is no fault, the information screen (when the operation mode is ON) is displayed.

If there is a fault, the screen changes to warning display.

Refer to “Warning display list” on page 6-26.

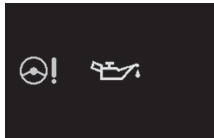

NOTE

- The system check screen display varies depending on the customer’s equipment.

EV cruising range display/ Total cruising range display

E00537600042

This displays the approximate driving range (how many more kilometres or miles you can drive).

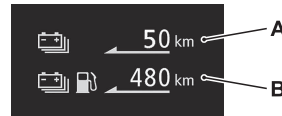

EV cruising range display (A)

This displays the distance that can be traveled with the remaining power in the drive battery.

Total cruising range display (B)

This displays the distance that can be traveled with the remaining power in the drive battery and the remaining amount of fuel.

NOTE

- The EV cruising range may vary depending on the driving conditions and your personal driving habits. The EV cruising range is calculated from the following information.
 - Current remaining power in the drive battery.
 - The most recent electric power consumption rate.

NOTE

- Operation status of the air-conditioner. If the preceding driving condition is in the following situations, the EV cruising range display may show less distance than before even though there is almost the same level of remaining power in the drive battery.
 - When much electricity is consumed from the drive battery, such as in a traffic jam, hill-climbing or high-speed driving.
 - When the air conditioner is operating.
 Treat the distance displayed as just a rough guideline. In addition, disconnecting the auxiliary battery cable will reset the EV cruising range and the EV cruising range display may show a different distance from the previous distance.
- The learned value for the EV cruising range can be reset by operating the multi information display switch. If the EV cruising range display shows an extremely different distance, please reset the learned value to the initialized value. For details, refer to “Reset of EV/Total cruising range” on page 6-22.
- When the drive battery is charged or the vehicle is refuelled, the cruising range display is updated. However, if the charge level is low or the refueling amount is small, it cannot be updated correctly. Fully charge the battery or refill to full tank whenever possible.

Multi information display

NOTE

- On rare occasions, the value displayed for the driving range may change if you are parked on an extremely steep incline. This is due to the movement of fuel in the tank and does not indicate a malfunction.
- The display setting can be changed to the preferred units (km or miles). Refer to “Changing the function settings” on page 6-17.
- When the EV cruising range falls below approximately 1 km (1 mile), the EV cruising range display shows “---”.
- When the total cruising range falls below approximately 50 km (30 miles), the total cruising range display shows “---”.

6

Average fuel consumption display

E00531201128

This displays the average fuel consumption from the last reset to the present time. There are the following 2 mode settings. Refer to “Changing the reset mode for average fuel consumption” on page 6-18. For information on how to change the average fuel consumption display setting, refer to “Changing the function settings” on page 6-17.

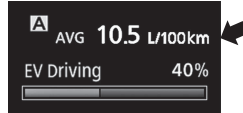

NOTE

- The average fuel consumption display can be reset separately for the auto reset mode and for the manual reset mode.
- “---” is displayed when the average fuel consumption cannot be measured.
- The initial (default) setting is “Auto reset mode”.
- The average fuel consumption depends on the driving condition (road condition, driving behavior, etc.). The displayed fuel consumption may vary from the actual fuel consumption. Treat the fuel consumption displayed as just a rough guideline.
- The memory of the auto reset mode or manual reset mode for the average fuel consumption display is erased if the auxiliary battery is disconnected.
- The display setting can be changed to the preferred units {km/L, mpg (US), mpg (UK) or L/100 km}. Refer to “Changing the function settings” on page 6-17.

EVHV driving rate display

E00537500038

This displays the ratios of the time travelled with electric power and the time travelled with both electric power and engine power.

OGGE19E1

The ratio of the time traveled with electric power is displayed with a bar graph (blue) and in a percentage.

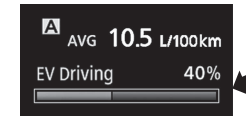

NOTE

- When the drive battery is fully charged, EVHV driving rate is reset and display becomes 100 %.

Energy flow display

E00537400040

This displays the flow of energy.

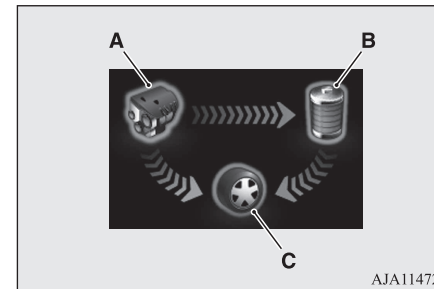

- A- Engine
- B- Drive battery
- C- Tyre

Blue arrow- Flow of electric energy
 Amber arrow- Flow of other energy

Display of energy flow (example)

When driving with electric energy

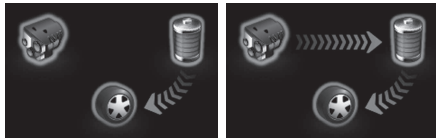

When driving with fuel (petrol) energy



When driving with both electric energy and fuel (petrol) energy



When charging the drive battery



When there is no energy flow



NOTE

● During charging, the energy flow display for charging is displayed. For details, refer to “Energy flow display during charging” on page 3-26.

ECO Score

ECO score indicates the points you have scored on fuel-efficient driving by the number of leaves as follows:

[When the operation mode is ON]
 The display shows the score you achieved in the last several minutes.

[When the operation mode is put in OFF]
 The display shows the overall ECO score the function has counted from the time when the operation mode is set to “ON” to the time when it is set to “OFF”.

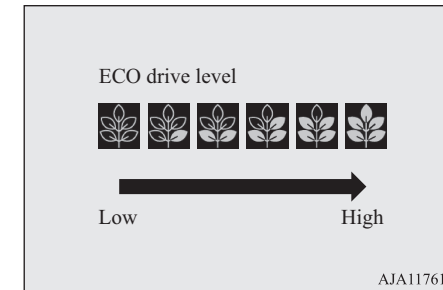

6

Changing the function settings

The “Display language”, “Temperature unit”, “Fuel consumption unit”, and “Average fuel consumption and speed reset method” etc. setting can be modified as desired.

1. Stop the vehicle in a safe place. Firmly apply the parking brake, and press the electrical parking switch and shift to “P” (PARK) position.
2. Lightly press the multi information display switch a few times to switch the information screen to the function setting screen.

Multi information display

Refer to “Information screen” on page 6-09.



6

CAUTION

- For safety, stop the vehicle before operating. While driving, even if you operate the multi information display switch, the function setting screen is not displayed.

3. Press and hold the multi information display switch for about 2 seconds or more to switch from the setting mode screen to the menu screen.

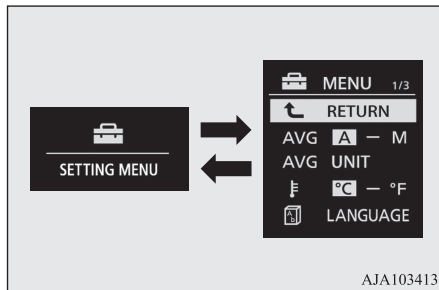

NOTE

- To return the menu screen to the function setting screen, press and hold the multi information display switch for about 2 seconds or more.
- If no operations are made within about 30 seconds of the menu screen being displayed, the display returns to the function setting screen.

4. Select the item to change on the menu screen and change to the desired setting. Refer to the following items for further details on the operation methods.

Refer to “Changing the reset mode for average fuel consumption” on page 6-18.

Refer to “Changing the fuel consumption display unit” on page 6-19.

Refer to “Changing the temperature unit” on page 6-20.

Refer to “Changing the display language” on page 6-20.

Refer to “Changing the language cooperative control” on page 6-21.

Refer to “Operation sound setting” on page 6-21.

Refer to “Changing the time until “REST REMINDER” is displayed” on page 6-22.

Refer to “Changing the turn-signal sound” on page 6-22.

Refer to “Reset of low tyre pressure warning threshold” on page 7-96.

Refer to “Tyre ID set change” on page 7-96.

Refer to “Reset of EV/Total cruising range” on page 6-22

Refer to “Returning to the factory settings” on page 6-22.

NOTE

- If the auxiliary battery is disconnected, these function settings are reset from memory and return automatically to the factory settings (except the low tyre pressure warning threshold and tyre ID set).

Changing the reset mode for average fuel consumption

E00522902243

The mode conditions for the average fuel consumption display can be switched between “Auto reset” and “Manual reset”.

1. Press and hold the multi information display switch for about 2 seconds or more to switch from the setting mode screen to the menu screen.

Refer to “Changing the function settings” on page 6-17.

- Lightly press the multi information display switch to select “AVG (average fuel consumption)”.

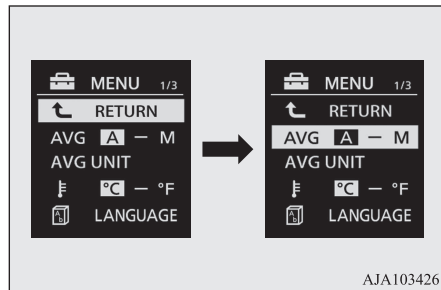

- Press and hold the multi information display switch for about 2 seconds or more to switch from A/1 (Auto reset mode) to M/2/P (Manual reset mode), or from M/2/P to A/1.

The setting is changed to the selected mode condition.

Manual reset mode

- When the average fuel consumption is being displayed, if you hold down the multi-information meter switch, the average fuel consumption displayed at that time is reset.

- When the operation mode is changed from ACC or OFF to ON, the mode setting is automatically switched from manual to auto.

Switching to auto occurs automatically. If switching to manual mode is done, however, the data from the last reset is displayed.

Auto reset mode

- When the average fuel consumption is being displayed, if you hold down the multi-information meter switch, the average fuel consumption displayed at that time is reset.
- When the operation mode is in ACC or OFF for about 4 hours or longer, the average fuel consumption display is automatically reset.

NOTE

- The average fuel consumption display can be reset separately for the auto reset mode and for the manual reset mode.
- The memory of the auto reset mode or manual reset mode for the average fuel consumption display is erased if the auxiliary battery is disconnected.

OGGE19E1

Changing the fuel consumption display unit

E00523001778

The display unit for fuel consumption can be switched. The distance and amount units are also switched to match the selected fuel consumption unit.

- Press and hold the multi information display switch for about 2 seconds or more to switch from the setting mode screen to the menu screen. Refer to “Changing the function settings” on page 6-17.
- Lightly press the multi information display switch to select “AVG UNIT (fuel consumption display setting)”.

6

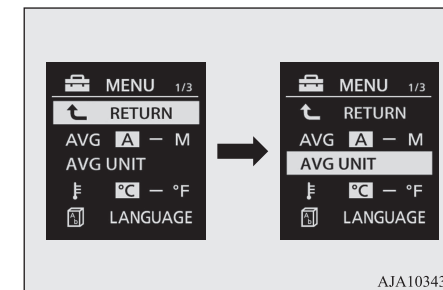

- Press and hold the multi information display switch for about 2 seconds or more to display “AVG UNIT”.

Multi information display

- Lightly press the multi information display switch to select the units.
- Press and hold the multi information display switch for about 2 seconds or more to change the setting to the selected unit.

NOTE

- The display units for the average fuel consumption and the driving range is switched, but the units for the indicating needle (speedometer), the odometer and the tripmeter will remain unchanged.

6

The distance units is also switched in the following combinations to match the selected fuel consumption unit.

Fuel consumption	Distance (driving range)
L/100 km	km
mpg (US)	mile(s)
mpg (UK)	mile(s)
km/L	km

Changing the temperature unit

E00523101913

The display unit for temperature can be switched.

- Press and hold the multi information display switch for about 2 seconds or more to switch from the setting mode screen to the menu screen.
Refer to “Changing the function settings” on page 6-17.
- Lightly press the multi information display switch to select “F” (temperature unit setting).
- Press and hold the multi information display switch for about 2 seconds or more to switch in from °C to °F, or from °F to °C. The setting is changed to the selected temperature unit.

NOTE

- The temperature value on air conditioner panel is switched in conjunction with outside temperature display unit of the multi information display.
However, “°C” or “°F” are not shown to temperature display of an air conditioner.
- On vehicles equipped with the Smartphone Link Display Audio or the MITSUBISHI Multi-Communication System (MMCS), the temperature value of Smartphone Link Display Audio or MITSUBISHI Multi-Communication System (MMCS) is switched in conjunction with the outside temperature display unit of the multi information display.
However, “°C” or “°F” is not shown to the air conditioner screen of MITSUBISHI Multi-Communication System (MMCS).

Changing the display language

E00523201741

The language of the multi information display can be switched.

- Press and hold the multi information display switch for about 2 seconds or more to switch from the setting mode screen to the menu screen.
Refer to “Changing the function settings” on page 6-17.
- Lightly press the multi information display switch to select “LANGUAGE” (language setting).

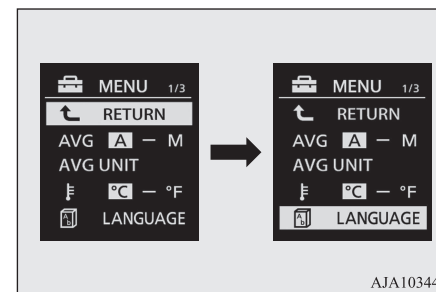

- Press and hold the multi information display switch for about 2 seconds or more to display “LANGUAGE”.
- Lightly press the multi information display switch to select the desired language.

5. If you hold down the multi information display switch for about 2 seconds or more, the setting is changed to the selected language.



NOTE

- If “--” is selected in the language setting, a warning message is not displayed when there is a warning display or interrupt display.

Changing the language cooperative control

E00523301827

The language used in MITSUBISHI Multi-Communication System (MMCS) (if so equipped), Bluetooth® 2.0 interface (if so equipped) or Multi Around Monitor (if so equipped) can be changed automatically to the same language as that shown in the multi information display.

1. Press and hold the multi information display switch for about 2 seconds or more to switch from the setting mode screen to the menu screen.
Refer to “Changing the function settings” on page 6-17.
2. Lightly press the multi information display switch to select  “A - M”  (language cooperative control).

3. Press and hold the multi information display switch to switch from A/1 (language cooperation enabled) to M/2/P (language cooperation disabled), or from M/2/P to A/1.

The setting is changed to the selected condition.

NOTE

- The language display modified with the language setting can be switched in the following manner.
 - When A or 1 has been selected with the language cooperative control, the language for MITSUBISHI Multi-Communication System (MMCS), Bluetooth® 2.0 interface or Multi Around Monitor is automatically changed to the language selected for the multi information display. However, this changing function may not work depending on the language selected for the multi information display.
 - When M, 2 or P has been selected with the language cooperative control, the language for MITSUBISHI Multi-Communication System (MMCS), Bluetooth® 2.0 interface or Multi Around Monitor is not automatically changed to the language selected for the multi information display.
- The language on the display of the audio system (if so equipped) is not automatically changed even if you select A or 1 of the language cooperative control.

Operation sound setting

E00523400690

You can turn off the operation sounds of the multi information display switch and rheostat illumination button.

1. Press and hold the multi information display switch for about 2 seconds or more to switch from the setting mode screen to the menu screen.
Refer to “Changing function settings” on page 6-17.
2. Lightly press the multi information display switch to select  (operation sound setting).
3. Press and hold the multi information display switch for about 2 seconds or more to switch from ON (operation sound on) to OFF (operation sound off), or from OFF to ON.
The setting is changed to the selected condition.

NOTE

- The operation sound setting only deactivates the operation sound of the multi information display switch and rheostat illumination button. The warning display and other sounds cannot be deactivated.

Multi information display

Changing the time until “REST REMINDER” is displayed

E00523501702

The time until the display appears can be changed.

1. Press and hold the multi information display switch for about 2 seconds or more to switch from the setting mode screen to the menu screen.

Refer to “Changing the function settings” on page 6-17.

2. Lightly press the multi information display switch to select “ALARM” (rest time setting).
3. Press and hold the multi information display switch for about 2 seconds or more to display “ALARM”.
4. Lightly press the multi information display switch to select the time until the display.
5. Press and hold the multi information display switch for about 2 seconds or more, the setting is changed to the selected time.

NOTE

- The drive time is reset when the operation mode of the power switch is put in OFF.

Changing the turn-signal sound

E00529100396

It is possible to change the turn-signal sound.

6-22 Instruments and controls

1. Press and hold the multi information display switch for about 2 seconds or more to switch from the setting mode screen to the menu screen.

Refer to “Changing the function settings” on page 6-17.

2. Lightly press the multi information display switch to select  (changing the turn-signal sound).
3. Press and hold the multi information display switch for about 2 seconds or more to switch from 1 (turn-signal sound 1) to 2 (turn-signal sound 2), or from 2 to 1. The setting changes to the selected turn-signal sound.

Reset of EV/Total cruising range

E00532200027

The learned value for EV cruising range resets to the initialized value.

1. Press and hold the multi information display switch for about 2 seconds or more to switch from the setting mode screen to the menu screen.

Refer to “Changing the function settings” on page 6-17.

2. Lightly press the multi information display switch to select “ RESET” (Reset of EV cruising range).

3. When you press and hold the multi information display switch for about 3 seconds or more, the buzzer sounds and the learned value resets to the default values.

Returning to the factory settings

E00523602205

Many of the function settings can be returned to their factory settings.

1. Press and hold the multi information display switch for about 2 seconds or more to switch from the setting mode screen to the menu screen.

Refer to “Changing the function settings” on page 6-17.

2. Lightly press the multi information display switch to select “ RESET” (returning to the factory settings).
3. When you press and hold the multi information display switch for about 5 seconds or more, the buzzer sounds and all of the function settings are returned to the factory settings.

NOTE

- The factory settings are as follows.
 - Average fuel consumption reset mode: A (Auto reset)
 - Fuel consumption display unit: L/100 km

 NOTE
<ul style="list-style-type: none">• Temperature unit: °C (Celsius)• Display language: ENGLISH or RUSSIAN• Cooperative language setting: A (language cooperation enabled)• Operation sounds: ON (Operation sounds on)• “REST REMINDER” display: OFF• Turn-signal sound: Turn-signal sound 1● The low tyre pressure warning threshold and tyre ID set cannot be returned to their factory settings.● The learned value for EV cruising range does not return to the initialized value.

Indication lamp, warning lamp, and information screen display list

Indication lamp, warning lamp, and information screen display list

E00523701267

Indication and warning lamp list

E00523802539

6

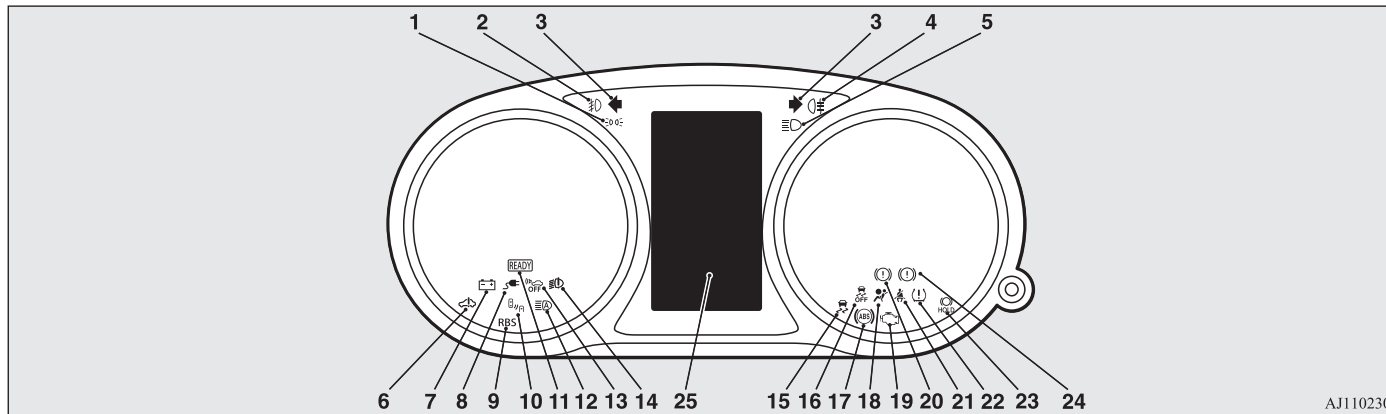

AJ1102300

- 1- Position lamp indication lamp → p. 6-55
- 2- Front fog lamp indication lamp → p. 6-55
- 3- Turn-signal indication lamps/Hazard warning indication lamps → p. 6-54
- 4- Rear fog lamp indication lamp → p. 6-55
- 5- High-beam indication lamp → p. 6-54

- 6- Plug-in Hybrid EV System warning lamp → p. 6-57
- 7- Auxiliary battery charge warning lamp → p. 6-57
- 8- Charging indicator → p. 6-55
- 9- Regenerative brake warning lamp → p. 6-58
- 10- Blind Spot Warning (BSW) indication lamp* → p. 7-82
- 11- Ready indicator → p. 6-55

- 12- Automatic High-Beam (AHB) indication lamp* → p. 6-62
- 13- Acoustic Vehicle Alerting System (AVAS) OFF indication lamp → p. 7-33
- 14- LED headlamp warning lamp* → p. 6-61
- 15- Active Stability Control (ASC) indication lamp → p. 7-45

6-24 Instruments and controls

OGGE19E1

Indication lamp, warning lamp, and information screen display list

16- Active Stability Control (ASC) OFF indication lamp → p. 7-45	19- Check engine warning lamp → p. 6-56	23- Brake auto hold indication lamp → p. 7-35
17- Anti-lock brake system (ABS) warning lamp → p. 7-41	20- Electric parking brake warning lamp (yellow) → p. 7-03	24- Brake warning lamp (red) → p. 6-55
18- Supplement Restraint System (SRS) warning lamp → p. 5-35	21- Seat belt warning lamp → p. 5-11	25- Information screen display list → p. 6-25
	22- Tyre pressure monitoring system warning lamp → p. 7-93	

Information screen display list

E00523901344

6

When there is information to be announced, such as lamp reminder, the buzzer sounds and the screen switches to the displays shown below. Refer to the appropriate page and take the necessary measures.

When the cause of the warning display is eliminated, the warning display goes out automatically.

Refer to “Warning display list” on page 6-26.

Refer to “Navigation information display” on page 6-47.

Refer to “Other interrupt displays” on page 6-48.

NOTE





- A warning may be displayed on the information screen and the buzzer may sound in the following rare cases. This is caused by the system picking up interference such as noise or strong electromagnetic waves, and is not a functional problem.
 - An extremely strong electromagnetic wave is received from a source such as an illegal radio set, a spark from a wire, or a radar station.
 - Abnormal voltage or a static electricity discharge is generated by the operation of installed electrical equipment (including after-market parts).If the warning display appears many times, we recommend you to consult a MITSUBISHI MOTORS Authorized Service Point.

Indication lamp, warning lamp, and information screen display list

Warning display list

E00524002727

6



Screen	Cause	Solution (Reference)
 <p>EV SYSTEM SERVICE REQUIRED</p>	<ul style="list-style-type: none"> ● One or more failure is occurring in the Plug-in Hybrid EV System. 	<ul style="list-style-type: none"> ● Have your vehicle inspected by a MITSUBISHI MOTORS Authorized Service Point.
 <p>EV SYSTEM SERVICE REQUIRED STOP SAFELY</p>	<ul style="list-style-type: none"> ● One or more failure is occurring in the Plug-in Hybrid EV System. 	<ul style="list-style-type: none"> ● Immediately park the vehicle in a safe place and contact a MITSUBISHI MOTORS Authorized Service Point.
 <p>P LOCK MALFUNCTION WHEN PARKING, APPLY PARKING BRAKE SECURELY</p>	<ul style="list-style-type: none"> ● The parking lock unit is in failure. The Plug-in Hybrid EV System cannot be kept in standstill condition without applying the parking brake. 	<ul style="list-style-type: none"> ● Park the vehicle at a safe, flat place and apply the parking brake. Contact a MITSUBISHI MOTORS Authorized Service Point. Refer to “Electrical Parking switch” on page 7-18.
 <p>CHARGE CABLE CONNECTED</p>	<ul style="list-style-type: none"> ● You are attempting to set the operation mode to “ON” when the charge connector is connected to the charge port. 	<ul style="list-style-type: none"> ● Disconnect the charge connector from the charge port before operating the power switch.
 <p>CHARGE INTERRUPTED BY SYSTEM MALFUNCTION</p>	<ul style="list-style-type: none"> ● Charging was interrupted due to system failure or EV charging cable failure. 	<ul style="list-style-type: none"> ● There is a system failure or the EV charging charge cable is faulty. Immediately stop using the cable and contact a MITSUBISHI MOTORS Authorized Service Point.

Indication lamp, warning lamp, and information screen display list



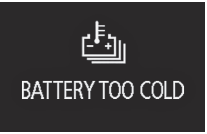

Screen	Cause	Solution (Reference)
	<ul style="list-style-type: none"> ● Normal charging <ul style="list-style-type: none"> • Charging was interrupted due to poor connection of the EV charging cable or power failure. ● Quick charging <ul style="list-style-type: none"> • Charging was stopped by your operation. • Charging was interrupted after the pre-determined set time. • Charging was interrupted due to a poor connection of the EV charging cable or an electrical power failure. • Charging was interrupted because there is a problem in the vehicle or the quick charger. 	<ul style="list-style-type: none"> ● Normal charging <ul style="list-style-type: none"> • Connect the EV charging cable correctly. Refer to “Normal charging” on page 3-10. • If charging is interrupted due to a power failure, charging will resume automatically when the power source is reset. ● Quick charging <ul style="list-style-type: none"> • Connect the EV charging cable correctly. Refer to “Quick charging” on page 3-17. • If charging is interrupted due to a power failure, start the charging procedure again from the beginning after the power source is reset. • If the warning display appears in the meter of the vehicle or on the quick charger display, follow the instructions and take the necessary measures.

6

Indication lamp, warning lamp, and information screen display list





Screen	Cause	Solution (Reference)
<div style="display: flex; align-items: center; justify-content: center;"> <div style="background-color: black; color: white; padding: 5px; margin-right: 10px;">6</div>  </div>	<ul style="list-style-type: none"> ● The drive battery temperature is too cold. ● The battery charge mode is selected when the drive battery temperature is cold. 	<ul style="list-style-type: none"> ● When the vehicle is under running, stop the vehicle in a safe place and contact a MITSUBISHI MOTORS Authorized Service Point. ● When the vehicle is parked during the daytime, wait for the outside temperature to rise and re-start the Plug-in hybrid system once the outside temperature has risen. Refer to “Cautions and actions to deal with intense cold” on page 2-10. ● You do not have to take any actions, but the time needed to charge the drive battery will become longer.
	<ul style="list-style-type: none"> ● The drive battery is extremely cold. The Plug-in Hybrid EV System will not start until the drive battery is warm enough. 	<ul style="list-style-type: none"> ● Even if the drive battery is fully charged, connect the EV charging cable (normal charger). Then, the drive battery warming system is operated and the drive battery is automatically warmed up. While the drive battery warming system is operating, “BATTERY TOO COLD” will be displayed. (Vehicles equipped with drive battery warming system) Refer to “Charging from rated AC 220-240 V outlet” on page 3-12. Refer to “Cautions and actions to deal with intense cold” on page 2-10

Indication lamp, warning lamp, and information screen display list



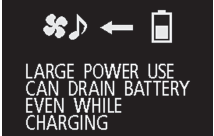

Screen	Cause	Solution (Reference)
	<ul style="list-style-type: none"> ● The drive battery is extremely cold. 	<ul style="list-style-type: none"> ● Stop the vehicle at a safe place if the vehicle is under running. When the vehicle has been parked during the daytime, wait for the outside temperature to rise and re-start the Plug-in Hybrid EV system once the outside temperature has risen. Refer to “Cautions and actions to deal with intense cold” on page 2-10
	<ul style="list-style-type: none"> ● Charging lid is open. 	<ul style="list-style-type: none"> ● Close the charge lid. Refer to “Charging from rated AC 220-240 V outlet” on page 3-12.
	<ul style="list-style-type: none"> ● When the air conditioner stops because the drive battery level becomes low by using the air conditioner during charging. 	<ul style="list-style-type: none"> ● Turn the power switch to OFF once the drive battery has been charged sufficiently, then turn the power switch to ON. The air conditioner can be used again.
	<ul style="list-style-type: none"> ● When the air conditioner can be used again in the following conditions. The drive battery is sufficiently charged when the “A/C AND HEAT ARE NOT AVAILABLE BATTERY CHARGE LOW” indication is displayed or the drive battery is sufficiently heated when the “BATTERY TOO COLD” indication is displayed, etc. 	<ul style="list-style-type: none"> ● Turn the power switch to OFF once, and then turn the power switch to ON. The air conditioner can be used again.

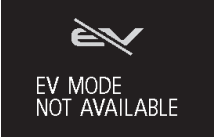
6

Indication lamp, warning lamp, and information screen display list

Screen	Cause	Solution (Reference)
	<ul style="list-style-type: none"> ● When the operation mode of the power switch is put in ON during charging. 	<ul style="list-style-type: none"> ● The electric devices can be used during charging. Refer to “How to use an electric device during charging” on page 3-24.
6 	<ul style="list-style-type: none"> ● EV priority mode is not available because the drive battery level is low. 	<ul style="list-style-type: none"> ● Refer to “EV switch” on page 7-25.
	<ul style="list-style-type: none"> ● EV priority mode is not available because the cruise control or the Adaptive Cruise Control System (ACC) is operating. 	
	<ul style="list-style-type: none"> ● EV priority mode is not available because the drive battery is too cold. 	
	<ul style="list-style-type: none"> ● EV priority mode is not available because the EV priority mode is limited to protect the Plug-in Hybrid EV System or the outside temperature is too low. 	



Indication lamp, warning lamp, and information screen display list

Screen	Cause	Solution (Reference)
 EV MODE CANCELED BATTERY CHARGE LOW	<ul style="list-style-type: none"> ● EV priority mode is cancelled because the drive battery level is low. 	
 EV MODE CANCELED CRUISE CONTROL SET	<ul style="list-style-type: none"> ● EV priority mode is cancelled because the vehicle speed of the cruise control or the Adaptive Cruise Control System (ACC) is set. 	
 EV MODE CANCELED BATTERY TOO COLD	<ul style="list-style-type: none"> ● EV priority mode is cancelled because the drive battery temperature has become too cold. 	
 EV MODE CANCELED	<ul style="list-style-type: none"> ● EV priority mode is cancelled because the protecting device of the Plug-in Hybrid EV System is operated. 	
 NO HEAT AVAILABLE TURN OFF EV MODE FOR HEATING	<ul style="list-style-type: none"> ● You have selected the warm air with the air conditioner switch while driving in the EV priority mode. (Vehicle without electric heater) 	
		<ul style="list-style-type: none"> ● If you want to use the heating, cancel the EV priority mode. Refer to “EV switch” on page 7-25.





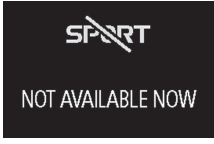
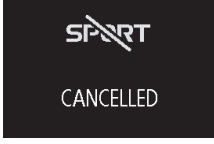
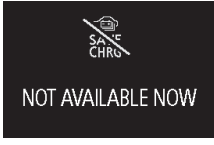

6

Indication lamp, warning lamp, and information screen display list

6



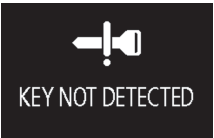

Screen	Cause	Solution (Reference)
	<ul style="list-style-type: none"> You have pressed the EV switch while heating. (Vehicle without electric heater) 	<ul style="list-style-type: none"> If you want to use the EV priority mode, stop the heating. Refer to “Automatic climate control air conditioner” on page 8-06
	<ul style="list-style-type: none"> SPORT mode is not available because the remaining fuel quantity is low. 	<ul style="list-style-type: none"> Refer to “SPORT mode switch” on page 7-31.
	<ul style="list-style-type: none"> SPORT mode is cancelled because the remaining fuel quantity has become low. 	
	<ul style="list-style-type: none"> Battery save mode or battery charge mode is not available because the engine coolant temperature is high or the remaining fuel quantity is low. 	<ul style="list-style-type: none"> Refer to “SAVE/CHARGE mode switch” on page 7-28.
	<ul style="list-style-type: none"> Battery save mode or battery charge mode is cancelled because the engine coolant temperature has become high or the remaining fuel quantity has become low. 	

Indication lamp, warning lamp, and information screen display list





Screen	Cause	Solution (Reference)
 <p>TURN OFF LIGHTS</p>	<ul style="list-style-type: none"> You have forgotten to turn off the lamps. 	<ul style="list-style-type: none"> Refer to “Lamps (headlamps, fog lamps, etc.) auto-cutout function” on page 6-59.
 <p>LOW WASHER FLUID</p>	<ul style="list-style-type: none"> The washer fluid is running low. 	<ul style="list-style-type: none"> Replenish the container with washer fluid. Refer to “Washer fluid” on page 11-08. Refer to “Refill capacities” on page 12-10.
 <p>LED HEADLIGHT SERVICE REQUIRED</p>	<ul style="list-style-type: none"> There is a fault in the LED headlamps. 	<ul style="list-style-type: none"> Have your vehicle inspected by a MITSUBISHI MOTORS Authorized Service Point. Refer to “LED headlamp warning lamp” on page 6-61.
 <p>KEY BATTERY LOW</p>  <p>KEY NOT DETECTED</p>  <p>KEY STILL IN VEHICLE</p>  <p>CHECK DOORS</p>	<ul style="list-style-type: none"> There is a fault in the keyless operation system. 	<ul style="list-style-type: none"> Refer to “Keyless operation system” on page 4-06.

6





Indication lamp, warning lamp, and information screen display list

Screen	Cause	Solution (Reference)
 KEYLESS OPERATION SYSTEM SERVICE REQUIRED		
6  KEY NOT DETECTED INSERT KEY INTO KEY SLOT	<ul style="list-style-type: none"> ● The keyless operation key is not detected. 	<ul style="list-style-type: none"> ● Insert the keyless operation key into the key slot. Refer to “If the keyless operation key is not operating properly” on page 7-15.
 REMOVE KEY FROM KEY SLOT	<ul style="list-style-type: none"> ● You have forgotten to remove the keyless operation key from the key slot. 	<ul style="list-style-type: none"> ● Remove the keyless operation key from the key slot. Refer to “Keyless operation key reminder” on page 7-15.
 POWER STEERING SERVICE REQUIRED	<ul style="list-style-type: none"> ● There is a fault in the EPS. 	<ul style="list-style-type: none"> ● Have the vehicle inspected by a MITSUBISHI MOTORS Authorized Service Point as soon as possible. Refer to “Electric power steering system (EPS)” on page 7-42.
 RBS! RBS SERVICE REQUIRED	<ul style="list-style-type: none"> ● The RBS (regenerative brake system) cannot be used. 	<ul style="list-style-type: none"> ● Have your vehicle inspected by a MITSUBISHI MOTORS Authorized Service Point.

Indication lamp, warning lamp, and information screen display list





Screen	Cause	Solution (Reference)
	<ul style="list-style-type: none"> ● There is a fault in the ABS. 	<ul style="list-style-type: none"> ● Avoid sudden braking and high-speed driving, stop the vehicle in a safe place, and take corrective measures. Refer to “ABS warning lamp/display” on page 7-41.
	<ul style="list-style-type: none"> ● The tyre pressure in one of the tyres is low. 	<ul style="list-style-type: none"> ● Refer to “Tyre pressure monitoring system warning lamp/display” on page 7-93.
	<ul style="list-style-type: none"> ● There is a fault in the tyre pressure monitoring system. 	<ul style="list-style-type: none"> ● Refer to “Tyre pressure monitoring system warning lamp/display” on page 7-93.
	<ul style="list-style-type: none"> ● One of the doors or the tailgate is not completely closed. The open door is displayed. 	<ul style="list-style-type: none"> ● Close the door or tailgate. Refer to “Door ajar warning display screen” on page 6-11.
	<ul style="list-style-type: none"> ● The bonnet is open. 	<ul style="list-style-type: none"> ● Close the bonnet. Refer to “Bonnet” on page 11-04.

Indication lamp, warning lamp, and information screen display list

Screen	Cause	Solution (Reference)
 <p>IMMOBILIZER SYSTEM SERVICE REQUIRED</p>	<ul style="list-style-type: none"> ● There is a fault in the electronic immobilizer (Anti-theft starting system). 	<ul style="list-style-type: none"> ● Put the operation mode in OFF, and then start the Plug-in Hybrid EV System again. If the warning is not cancelled, please contact a MITSUBISHI MOTORS Authorized Service Point.
 <p>OFF</p>	<ul style="list-style-type: none"> ● The driver's door is open when the operation mode is in any mode other than OFF. 	<ul style="list-style-type: none"> ● Put the operation mode in OFF. Refer to "Operation mode ON reminder system" on page 7-13.
	<ul style="list-style-type: none"> ● An attempt was made to lock all the doors and the tailgate when the operation mode is in any mode other than OFF. 	<ul style="list-style-type: none"> ● Put the operation mode in OFF. Refer to "Operation mode OFF reminder system" on page 7-13.
 <p>ELECTRICAL SYSTEM SERVICE REQUIRED</p>	<ul style="list-style-type: none"> ● There is a fault in the electrical system. 	<ul style="list-style-type: none"> ● Immediately stop the vehicle in a safe place. We recommend you to contact a MITSUBISHI MOTORS Authorized Service Point.
 <p>ENGINE OVERHEATING STOP SAFELY</p>	<ul style="list-style-type: none"> ● The engine is overheated. 	<ul style="list-style-type: none"> ● Stop the vehicle in a safe place and take corrective measures. Refer to "Engine overheating" on page 9-04.
 <p>FASTEN SEAT BELT</p>	<ul style="list-style-type: none"> ● You put the operation mode in ON without fastening your seat belt. 	<ul style="list-style-type: none"> ● Fasten your seat belt properly. Refer to "Seat belt reminder" on page 5-11.

6





Indication lamp, warning lamp, and information screen display list

Screen	Cause	Solution (Reference)
 FUEL SYSTEM SERVICE REQUIRED	<ul style="list-style-type: none"> ● There is a fault in the fuel system. 	<ul style="list-style-type: none"> ● We recommend you to have it checked, immediately.
 REFUEL	<ul style="list-style-type: none"> ● The fuel is running low. 	<ul style="list-style-type: none"> ● Refuel as soon as possible. Refer to “Fuel remaining warning display” on page 6-12.
 RELEASE PARKING BRAKE	<ul style="list-style-type: none"> ● You are driving with the parking brake still applied. 	<ul style="list-style-type: none"> ● Release the parking brake. Refer to “Brake warning display” on page 6-58.
 BRAKE SYSTEM SERVICE REQUIRED	<ul style="list-style-type: none"> ● The brake fluid level in the reservoir has fallen to a low level. ● There is a fault in the brake system. 	<ul style="list-style-type: none"> ● Immediately stop the vehicle in a safe place. We recommend you to consult a MITSUBISHI MOTORS Authorized Service Point. Refer to “Brake warning display” on page 6-58.
	<ul style="list-style-type: none"> ● When the brake pedal has been repeatedly depressed over a short period of time, the brake warning lamp may come on and the brake warning buzzer may sound, and this warning may be displayed. 	<ul style="list-style-type: none"> ● If this warning display has disappeared and the brake warning lamp goes out and the buzzer stops a few seconds after stopping the brake operation, there is no abnormality.





6

Indication lamp, warning lamp, and information screen display list



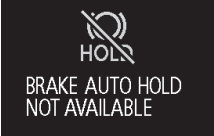

6

Screen	Cause	Solution (Reference)
 PARKING BRAKE SERVICE REQUIRED	<ul style="list-style-type: none"> ● There is a fault with the Electric parking brake. 	<ul style="list-style-type: none"> ● We recommend you to have it checked, immediately. Refer to “Electric parking brake” on page 7-03.
 PARKING BRAKE TEMPORARILY NOT AVAILABLE	<ul style="list-style-type: none"> ● The parking brake cannot be applied temporarily due to repeated operation of the Electric parking brake switch within a short time. 	<ul style="list-style-type: none"> ● Refer to “Electric parking brake” on page 7-03.
 BRAKE PRESS BRAKE PEDAL TO RELEASE	<ul style="list-style-type: none"> ● You try to release the Electric parking brake switch without depressing the brake pedal. 	<ul style="list-style-type: none"> ● Refer to “Electric parking brake” on page 7-03.
 PARKING BRAKE ENGAGED	<ul style="list-style-type: none"> ● The Electric parking brake has been automatically applied. 	<ul style="list-style-type: none"> ● Refer to “Brake auto hold” on page 7-35.
 HOLD BRAKE AUTO HOLD CANCELED	<ul style="list-style-type: none"> ● The brake auto hold is automatically cancelled. 	<ul style="list-style-type: none"> ● Refer to “Brake auto hold” on page 7-35.

Indication lamp, warning lamp, and information screen display list





Screen	Cause	Solution (Reference)
	<ul style="list-style-type: none"> The brake auto hold is not available. 	<ul style="list-style-type: none"> Refer to “Brake auto hold” on page 7-35.
	<ul style="list-style-type: none"> The brake auto hold system does not turn on because the driver’s seat belt is not fastened. 	<ul style="list-style-type: none"> Press the brake auto hold switch after fastening the driver’s seat belt. Refer to “Brake auto hold” on page 7-35.
	<ul style="list-style-type: none"> The brake auto hold system does not turn off because the brake pedal is not pressed. 	<ul style="list-style-type: none"> Depress the brake pedal more firmly than usual with the right foot. Then, press the brake auto hold switch. Refer to “Brake auto hold” on page 7-35.
	<ul style="list-style-type: none"> There is a fault in the engine oil circulation system. 	<ul style="list-style-type: none"> Immediately stop the vehicle in a safe place. We recommend you to have it checked. Refer to “Oil pressure warning display” on page 6-58.
	<ul style="list-style-type: none"> There is a fault in the Supplemental restraint system (SRS) airbag or the pretensioner system. 	<ul style="list-style-type: none"> We recommend you to have it checked, immediately. Refer to “SRS warning lamp/display” on page 5-35.

Indication lamp, warning lamp, and information screen display list

Screen	Cause	Solution (Reference)
	<ul style="list-style-type: none"> ● There is a fault in the Active Stability Control (ASC). 	<ul style="list-style-type: none"> ● We recommend you to have it checked. Refer to “Active stability control (ASC)” on page 7-43.
	<ul style="list-style-type: none"> ● There is a fault in the hill start assist. 	<ul style="list-style-type: none"> ● We recommend you to have it checked. Refer to “Hill start assist” on page 7-37.
	<ul style="list-style-type: none"> ● The outside temperature is 3 °C (37 °F) or less. 	<ul style="list-style-type: none"> ● Be careful of ice on the road. ● The road can be icy even when this warning is not displayed, so drive carefully.
	<ul style="list-style-type: none"> ● The Adaptive Cruise Control System (ACC) has detected the approach of the vehicles in front. 	<ul style="list-style-type: none"> ● Increase the following distance by depressing the brake pedal or marking other decelerating control. Refer to “Adaptive Cruise Control System (ACC): Proximity alarm” on page 7-58.
	<ul style="list-style-type: none"> ● The Forward Collision Mitigation System (FCM) has detected the danger of collision. 	<ul style="list-style-type: none"> ● Take appropriate action such as depressing the brake to avoid collision. Refer to “Forward collision warning function” on page 7-68.
	<ul style="list-style-type: none"> ● The Adaptive Cruise Control System (ACC) detected a stop of the vehicle in front and stopped your vehicle, but the brake will be released soon. 	<ul style="list-style-type: none"> ● Depress the brake pedal as soon as your vehicle comes to a stop. Refer to “Adaptive Cruise Control System (ACC)” on page 7-55.
	<ul style="list-style-type: none"> ● The Electric parking brake cannot be applied automatically. 	<ul style="list-style-type: none"> ● Depress the brake pedal as soon as possible. Refer to “Brake auto hold” on page 7-35.

6





Indication lamp, warning lamp, and information screen display list

Screen	Cause	Solution (Reference)
	<ul style="list-style-type: none"> ● The Adaptive Cruise Control System (ACC) control is automatically cancelled and the system is placed in the 'standby' state. 	<ul style="list-style-type: none"> ● Refer to "How to use ACC" on page 7-61.
	<ul style="list-style-type: none"> ● Conditions for the start of control are not met, the Adaptive Cruise Control System (ACC) can not start the control. 	
	<ul style="list-style-type: none"> ● The Adaptive Cruise Control System (ACC) can not start the control because the speed is out of speed range. 	
	<ul style="list-style-type: none"> ● The Adaptive Cruise Control System (ACC) can not start the control because not detected the approach of the vehicles in front. 	
	<ul style="list-style-type: none"> ● The Adaptive Cruise Control System (ACC) is not available temporarily such as for adhesion of contaminants to the sensor. This is not a malfunction. 	





6

Indication lamp, warning lamp, and information screen display list

6

Screen	Cause	Solution (Reference)
	<ul style="list-style-type: none"> ● There is a fault in the Adaptive Cruise Control System (ACC). 	<ul style="list-style-type: none"> ● We recommend you to have it checked. Refer to “Adaptive Cruise Control System (ACC)” on page 7-55.
	<ul style="list-style-type: none"> ● There is a fault in the Forward Collision Mitigation System (FCM). 	<ul style="list-style-type: none"> ● We recommend you to have it checked. Refer to “Forward Collision Mitigation System (FCM)” on page 7-67.
	<ul style="list-style-type: none"> ● FCM braking function of the Forward Collision Mitigation System (FCM) has been activated. 	<ul style="list-style-type: none"> ● Refer to “FCM braking function” on page 7-69.
	<ul style="list-style-type: none"> ● The Forward Collision Mitigation System (FCM) is temporarily unavailable for some reason. This is not a malfunction. 	
	<ul style="list-style-type: none"> ● The Lane Departure Warning (LDW) has detected that your vehicle is about to leave or has left the lane. 	<ul style="list-style-type: none"> ● Refer to “Lane Departure Warning (LDW)” on page 7-88.





Indication lamp, warning lamp, and information screen display list

Screen	Cause	Solution (Reference)
 <p>LDW SERVICE REQUIRED</p>	<ul style="list-style-type: none"> ● There is a fault in the Lane Departure Warning (LDW). 	<ul style="list-style-type: none"> ● We recommend you to have it checked. Refer to “Lane Departure Warning (LDW)” on page 7-88.
 <p>UMS TEMPORARILY NOT AVAILABLE</p>  <p>UMS (FRONT) TEMPORARILY NOT AVAILABLE</p>  <p>UMS (REAR) TEMPORARILY NOT AVAILABLE</p>	<ul style="list-style-type: none"> ● The Ultrasonic misacceleration Mitigation System (UMS) sensor is temporarily not available for some reason such as the environmental condition or increase of the sensor temperature. 	<ul style="list-style-type: none"> ● When the warning display does not disappear after waiting for a while, contact a MITSUBISHI MOTORS Authorized Service Point. Refer to “Ultrasonic misacceleration Mitigation System (UMS)” on page 7-77.



6

Indication lamp, warning lamp, and information screen display list

6



Screen	Cause	Solution (Reference)
  	<ul style="list-style-type: none"> ● The Ultrasonic misacceleration Mitigation System (UMS) does not operate normally because there are some malfunctions in the sensor or the system. 	<ul style="list-style-type: none"> ● Immediately have your vehicle inspected at a MITSUBISHI MOTORS Authorized Service Point. Refer to “Ultrasonic misacceleration Mitigation System (UMS)” on page 7-77.
 	<ul style="list-style-type: none"> ● The Ultrasonic misacceleration Mitigation System (UMS) is activated. 	<ul style="list-style-type: none"> ● Refer to “Ultrasonic misacceleration Mitigation System (UMS)” on page 7-77.

Indication lamp, warning lamp, and information screen display list

Screen	Cause	Solution (Reference)
	<ul style="list-style-type: none"> The Blind Spot Warning (BSW) sensor is temporarily not available for some reason such as the environmental condition or increase of the sensor temperature. 	<ul style="list-style-type: none"> When the warning display does not disappear after waiting for a while, contact a MITSUBISHI MOTORS Authorized Service Point. Refer to “Blind Spot Warning (BSW)” on page 7-82.
	<ul style="list-style-type: none"> The Blind Spot Warning (BSW) does not operate normally because there are some malfunctions in the sensor or the system. 	<ul style="list-style-type: none"> We recommend you to have it checked, immediately. Refer to “Blind Spot Warning (BSW)” on page 7-82.
	<ul style="list-style-type: none"> Foreign objects, such as dirt, snow or ice, adhere to the bumper surface around the sensor. 	<ul style="list-style-type: none"> Remove a foreign object on the bumper surface around the sensor. When the warning display does not disappear after having cleaned the bumper surface around the sensor, contact a MITSUBISHI MOTORS Authorized Service Point. Refer to “Blind Spot Warning (BSW): When there is a foreign objects on the sensor” on page 7-86.
	<ul style="list-style-type: none"> The Rear Cross Traffic Alert (RCTA) has detected a vehicle that is approaching your vehicle. 	<ul style="list-style-type: none"> Pay special attention to the rear of your vehicle. Refer to “Rear Cross Traffic Alert (RCTA)” on page 7-86.

6

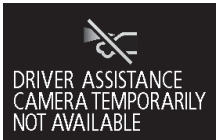
Indication lamp, warning lamp, and information screen display list

Screen	Cause	Solution (Reference)
<div style="display: flex; align-items: center;"> <div style="background-color: black; color: white; padding: 5px; margin-right: 10px; font-weight: bold; font-size: 1.2em;">6</div>  </div>	<ul style="list-style-type: none"> ● There is a fault in the sensor. 	<ul style="list-style-type: none"> ● We recommend you to contact a MITSUBISHI MOTORS Authorized Service Point. Refer to “Forward Collision Mitigation System (FCM): When a problem is detected” on page 7-73. Refer to “Lane Departure Warning (LDW): System problem warning” on page 7-90. Refer to “Automatic High-Beam (AHB): System problem warning” on page 6-64.
	<ul style="list-style-type: none"> ● The Forward Collision Mitigation System (FCM), Lane Departure Warning (LDW) and Automatic High-Beam (AHB) are temporarily unavailable due to the high or low temperature of the sensor. 	<ul style="list-style-type: none"> ● After the temperature of the sensor has been in range, the system will automatically return to operation. Refer to “Forward Collision Mitigation System (FCM): When a problem is detected” on page 7-73. Refer to “Lane Departure Warning (LDW): System problem warning” on page 7-90. Refer to “Automatic High-Beam (AHB): System problem warning” on page 6-64.
	<ul style="list-style-type: none"> ● The sensor is temporarily unavailable due to conditions such as the adhesion of contaminants to the sensor or windscreen. This is not a malfunction. 	<p>Refer to “Forward Collision Mitigation System (FCM): When a problem is detected” on page 7-73. Refer to “Lane Departure Warning (LDW): System problem warning” on page 7-90. Refer to “Automatic High-Beam (AHB): System problem warning” on page 6-64.</p>

Indication lamp, warning lamp, and information screen display list

Screen	Cause	Solution (Reference)
	<ul style="list-style-type: none"> There is a fault in the Automatic High-Beam (AHB). 	<ul style="list-style-type: none"> We recommend you to contact a MITSUBISHI MOTORS Authorized Service Point. Refer to “Automatic High-Beam (AHB): System problem warning” on page 6-64.

Navigation information display*

E00531401061

On vehicles equipped with MITSUBISHI Multi-Communication System (MMCS), the following information on navigation will be displayed when guidance location such as junction and destination is approached after you set the destination and started the route guidance.

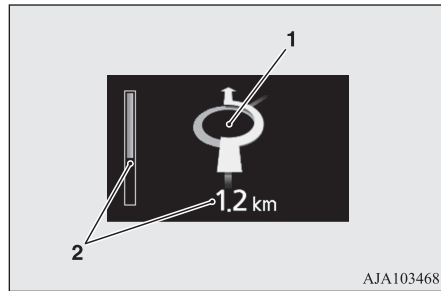

1- Guidance display

Shows the direction of vehicle travel and the guidance location.

6

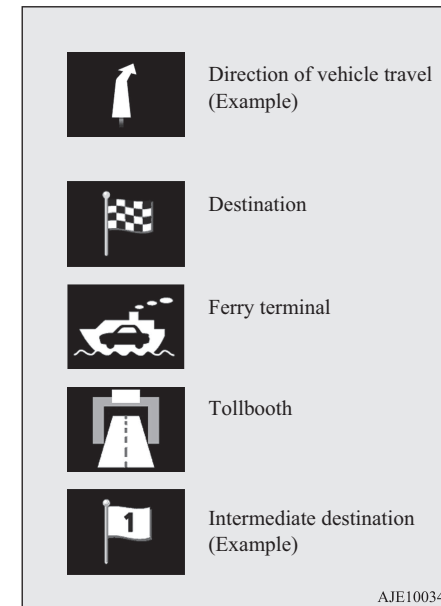

OGGE19E1

Instruments and controls 6-47

Indication lamp, warning lamp, and information screen display list

- 2- Remaining distance display
Shows the distance to the location where the guidance is displayed.



NOTE

- Please read this section and also the separate owner's manual for MITSUBISHI Multi-Communication System (MMCS).



Other interrupt displays

E00524202556

6

Screen	Cause	Solution (Reference)
	<ul style="list-style-type: none"> ● When you pressed the power switch and the operation mode become the ACC without depress the brake pedal, this screen is displayed. This screen will be displayed repeatedly at regular intervals while the operation mode of the power switch is put in ACC. ● When Plug-in Hybrid EV System does not start even if the operation mode of the power switch is put in ON, this screen is displayed. 	<ul style="list-style-type: none"> ● Place the select position in the "P" (PARK) position, depress the brake pedal more firmly than usual with the right foot. Then, press the power switch. Refer to "Starting and stopping the Plug-in Hybrid EV System" on page 7-13.
	<ul style="list-style-type: none"> ● When starting the Plug-in Hybrid EV System, you pressed the power switch without select position in the "P" (PARK) position. 	<ul style="list-style-type: none"> ● Place the select position in the "P" (PARK) position by pressing the electrical parking switch, depress the brake pedal more firmly than usual with the right foot. Then, press the power switch. Refer to "Starting and stopping the Plug-in Hybrid EV System" on page 7-13.



Indication lamp, warning lamp, and information screen display list

Screen	Cause	Solution (Reference)
 <p>PROPULSION POWER IS REDUCED</p>	<ul style="list-style-type: none"> ● Driving power is restricted by the safety system as the Plug-in Hybrid EV System has become too hot or too cold. 	<ul style="list-style-type: none"> ● You do not have to take any actions. The restriction on the driving power will be released when the Plug-in Hybrid EV System returns to the normal temperature.
 <p>REFUEL 15L(4GAL) OR MORE AT ONE TIME TO REFRESH FUEL</p>	<ul style="list-style-type: none"> ● The vehicle had not been refueled about 15 litres or more at one time for nearly 3 months. This display may appear frequently depending on the use conditions of your vehicle such as when fuel has been staying in the fuel tank for a long time. 	<ul style="list-style-type: none"> ● Refill the 15 litres more at one time. This display will disappear. If the fuel remaining display will be below half, you can refill the fuel more than 15 litres certainly. ● If you cannot refill the fuel due to the large amount of remaining fuel, start the engine and drive the vehicle enough to reduce the fuel level to approximately half tank.
 <p>CONSUMING OLD FUEL, ENGINE STOPS AFTER REFUELING 15L(4GAL)</p>	<ul style="list-style-type: none"> ● If the vehicle had not been refuelled about 15 litres or more at one time for three months, the engine starts automatically for the maintenance of the engine or the fuel system components while the ready indicator is illuminated. This display may appear frequently depending on the use conditions of your vehicle such as when fuel has been staying in the fuel tank for a long time. When the engine is running, this display shows the state where the drive battery is charged, and the battery charge mode display (🔋 CHARGE) is displayed. But the drive battery will not be full charge. 	<ul style="list-style-type: none"> ● Refill the 15 litres more at one time. This display and battery charge mode display will disappear, and the engine will not automatically start for maintenance. If the fuel remaining display will be below half, you can refill the fuel more than 15 litres certainly. ● If you cannot refill the fuel due to the large amount of remaining fuel, start the engine and drive the vehicle enough to reduce the fuel level to approximately half tank.



6

Indication lamp, warning lamp, and information screen display list





6

Screen	Cause	Solution (Reference)
	<ul style="list-style-type: none"> The accelerator pedal has been depressed when the select position is in the “N” (NEUTRAL) position. 	<ul style="list-style-type: none"> When you start the vehicle, be sure to check the select position indicator and make sure the select position is in the “D” (DRIVE) or “R” (REVERSE) position. Then, please depress the accelerator pedal. Refer to “Select position indicator” on page 7-17.
	<ul style="list-style-type: none"> The selector lever has been operated when the select position is in “P” (PARK) position and the brake pedal is not depressed. 	<ul style="list-style-type: none"> Operate the selector lever while depressed firmly on the brake pedal.

The operation status of each system is displayed on the information screen. Refer to the appropriate page for the system for further details.

Screen	System operation status	Reference
	<ul style="list-style-type: none"> When charging of the drive battery is completed. 	Refer to “Charging” on page 3-02.
	<ul style="list-style-type: none"> When “NORMAL” mode of S-AWC is selected 	Refer to “S-AWC drive mode” on page 7-21.





Indication lamp, warning lamp, and information screen display list

Screen	System operation status	Reference
	<ul style="list-style-type: none"> When "SNOW" mode of S-AWC is selected 	Refer to "S-AWC drive mode" on page 7-21.
	<ul style="list-style-type: none"> When "LOCK" mode of S-AWC is selected 	Refer to "S-AWC drive mode" on page 7-21.
	<ul style="list-style-type: none"> When the mode is changed by the ECO mode switch. 	Refer to "ECO mode switch" on page 6-68.
	<ul style="list-style-type: none"> When approaching the guidance location, etc. 	Refer to "Navigation information display" on page 6-47.
	<ul style="list-style-type: none"> When the EV priority mode is activated. 	Refer to "EV switch" on page 7-25.



6

Indication lamp, warning lamp, and information screen display list

6

Screen	System operation status	Reference
	<ul style="list-style-type: none"> ● When the battery save mode is activated. 	Refer to “Battery save mode” on page 7-29.
	<ul style="list-style-type: none"> ● When the battery charge mode is activated. 	Refer to “Battery charge mode” on page 7-29.
	<ul style="list-style-type: none"> ● When the SPORT mode is activated 	Refer to “SPORT mode switch” on page 7-31.
	<ul style="list-style-type: none"> ● When the reversing sensor system detects an obstruction. 	Refer to “Reversing sensor system” on page 7-97.
	<ul style="list-style-type: none"> ● When the parking sensors detect an obstacle. 	Refer to “Parking sensors (Front/Rear)” on page 7-101.

Indication lamp, warning lamp, and information screen display list

Screen	System operation status	Reference
 	<ul style="list-style-type: none"> When the Forward Collision Mitigation System (FCM) is activated or the timing of an alarm is changed. 	Refer to “FCM and UMS ON/OFF switch” on page 7-72.
	<ul style="list-style-type: none"> When the Forward Collision Mitigation System (FCM) is deactivated. When the Ultrasonic misacceleration Mitigation System (UMS) is deactivated. 	Refer to “FCM and UMS ON/OFF switch” on page 7-72. Refer to “To turn on/off the UMS” on page 7-82.

6

This informs you that a periodic inspection is due.

Screen	Solution
	We recommend you to have it checked. Refer to “Service reminder” on page 6-13.

Indication lamps

The setting for rest interval can be changed.

6

Screen	Solution
	<p>Stop the vehicle in a safe place, stop the Plug-in Hybrid EV system, and take a rest. Use this display as rough guide for taking rests during a long drive. The interval from the start of your trip until this message is displayed can be set. Refer to “Changing the time until REST REMINDER is displayed” on page 6-22. The display and buzzer alert the driver when the set time is reached. If you continue to drive without having a rest, the buzzer sounds about every 5 minutes to encourage you to take a rest.</p> <ul style="list-style-type: none"> ● In the following cases, the time driven is reset and the display returns to the previous display screen. After this, when the set time is reached again, the buzzer and display encourage you to take a rest. <ul style="list-style-type: none"> • The buzzer sounds 3 times. • Put the operation mode in OFF. • The multi information display switch is held for about 2 seconds or more.

Indication lamps

E00501600100

Turn-signal indication lamps/ Hazard warning indication lamps

E00501701427

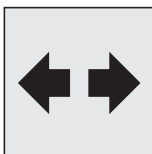

These indication lamps blink in the following situations.

- When the turn-signal lever is moved to activate a turn-signal lamp. Refer to “Turn-signal lever” on page 6-67.

- When the hazard warning flasher switch is pressed to activate the hazard warning lamps. Refer to “Hazard warning flasher switch” on page 6-67.
- When the hazard warning lamps automatically activate due to sudden braking while driving. (Vehicle equipped with emergency stop signal system) Refer to “Emergency stop signal system” on page 7-39.

High-beam indication lamp

E00501800173

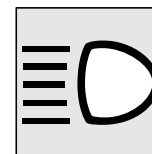

This indication lamp illuminates when the high-beam is used.

Front fog lamp indication lamp

E00501901650

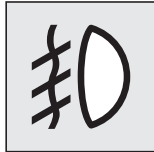

This lamp illuminates while the front fog lamps are on.

Rear fog lamp indication lamp

E00502001241

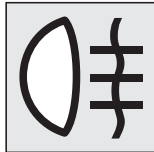

This lamp illuminates while the rear fog lamp is on.

Position lamp indication lamp

E00508900173

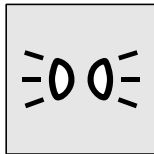

This indication lamp illuminates while the position lamps are on.

Ready indicator

E00530101061



The ready indicator keeps flashing until the Plug-in Hybrid EV System is activated. When the Plug-in Hybrid EV System has activated normally and the vehicle becomes ready to run, the lamp stops flashing and stays lit. Refer to “Starting the Plug-in Hybrid EV System” on page 7-13. If the indicator keeps flashing, the vehicle cannot be driven.

Charging indicator

E00530201062

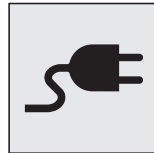

This indicator flashes when the EV charging cable or quick charging cable is connected. After that, the lamp switches to being illuminated when charging starts and goes out when charging is completed.

NOTE

- Although it is possible to start the Plug-in Hybrid EV System if quick charging has not finished normally, the charging indicator is continuously blinking. Refer to “Charging troubleshooting guide” on page 3-28.

Warning lamps

E00502400147

6**Brake warning lamp (red)**

E00502504016

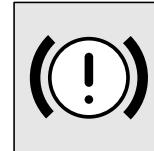

This lamp illuminates when the operation mode of the power switch is put in ON, and goes off after a few seconds.

Always make sure that the lamp goes off before driving. With the operation mode in ON, the brake warning lamp illuminates under the following conditions:

- When the parking brake lever has been engaged.
- When the brake fluid level in the reservoir falls to a low level.
- When the braking system is an abnormality.

With the operation mode in ON, a buzzer sounds under the following condition:

Warning lamps

- The vehicle speed exceeds 8 km/h (5 mph) with the parking brake applied.

CAUTION

- In the situations listed below, brake performance may be compromised or the vehicle may become unstable if brakes are applied suddenly; consequently, avoid driving at high speeds or applying the brakes suddenly. Furthermore, the vehicle should be brought to a stop in a safe location and to have it checked.
 - The brake warning lamp does not illuminate when the parking brake is applied or does not turn off when the parking brake is released.
 - The ABS warning lamp and brake warning lamp illuminate at the same time. For details, refer to “ABS warning lamp/display” on page 7-41.
 - The brake warning lamp remains illuminated during driving.
- The vehicle should be brought to a halt in the following manner when brake performance has deteriorated.
 - Depress the brake pedal harder than usual. Even if the brake pedal moves down to the very end of its possible stroke, keep it pressed down hard.

6

CAUTION

- Should the brakes fail, use regenerative braking to reduce your speed and keep pulling the Electric parking brake switch. (Refer to “Electric parking brake” on page 7-03.)
Depress the brake pedal to operate the stop lamp to alert the vehicles behind you.

Electric parking brake warning lamp (yellow)

E00568900100



This warning lamp will illuminate when there is a fault in the Electric parking brake system.

Normally, this warning lamp illuminates when the operation mode of the power switch is put in ON, and goes off in a few seconds.

CAUTION

- When the warning lamp remains on or does not come on, there is a possibility that the parking brake cannot be operated or released. Immediately contact the nearest MITSUBISHI MOTORS Authorized Service Point. When the warning lamp comes on during driving, immediately stop the vehicle in a safe place, and contact your MITSUBISHI MOTORS Authorized Service Point. If you inevitably have to park, park the vehicle on level and stable ground, press the electrical parking switch and place chocks or blocks.

Check engine warning lamp

E00502602938

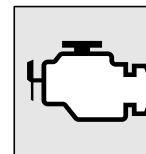

This lamp is a part of an on-board diagnostic system which monitors the emissions, engine control system. If a problem is detected in one of these systems, this

lamp illuminates or flashes.

Although your vehicle will usually be drivable and not need towing, we recommend you to have the system checked as soon as possible.

This lamp will also illuminate when the operation mode of the power switch is put in ON, and goes off after the Plug-in Hybrid EV System has started. If it does not go off after the Plug-in Hybrid EV System has started, we recommend you to have the vehicle checked.

CAUTION

- Prolonged driving with this lamp on may cause further damage to the emission control system. It could also affect fuel economy and drivability.
- If the lamp does not illuminate when the operation mode is put in ON, we recommend you to have the system checked.
- If the lamp illuminates while the Plug-in Hybrid EV System is operating, avoid driving at high speeds and have the system inspected by a MITSUBISHI MOTORS Authorized Service Point as soon as possible.

NOTE

- The engine electronic control module accommodating the onboard diagnostic system has various fault data (especially about the exhaust emission) stored.

This data will be erased if a auxiliary battery cable is disconnected which will make a rapid diagnosis difficult. Do not disconnect a auxiliary battery cable when the check engine warning lamp is ON.

Auxiliary battery charge warning lamp

E00502702287

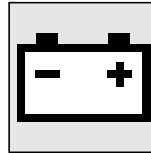

This warning lamp will illuminate when there is a fault with the charging system of the auxiliary battery.

Normally, when the operation mode of the power switch is put in ON, this warning lamp will illuminate. Then, when the Plug-in Hybrid EV System is started and the ready indicator illuminates, the warning lamp will go out.

CAUTION

- If the warning lamp stays on after the ready indicator illuminates, there may be a problem with the charging system for the auxiliary battery.
 - Immediately park your vehicle in a safe place and we recommend you to have it checked.
 - Do not charge the auxiliary battery.

Plug-in Hybrid EV System warning lamp

E00537300049

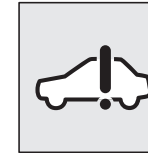

This warning lamp will illuminate when there is a fault at the Plug-in Hybrid EV System.

Refer to “Service precautions” on page 11-02.

Normally, this warning lamp illuminates when the operation mode of the power switch is put in ON, and goes off after a few seconds.

CAUTION

- If the warning lamp illuminates and “EV SYSTEM SERVICE REQUIRED STOP SAFELY” warning is displayed on the multi information display while the Plug-in Hybrid EV System is running, park your vehicle in a safe place as soon as possible and contact a MITSUBISHI MOTORS Authorized Service Point to have the system checked.



Information screen display

Regenerative brake warning lamp

E00537200048

RBS

This warning lamp will illuminate when the regenerative brake cannot be used, while the Plug-in Hybrid EV System is operating.

6

The warning is also displayed on the multi information display. Normally, this warning lamp illuminates when the operation mode of the power switch is put in ON, and goes off after the Plug-in Hybrid EV System is activated.

CAUTION

- If the lamp illuminates while the Plug-in Hybrid EV System is operating, we recommend you to have the vehicle inspected by a MITSUBISHI MOTORS Authorized Service Point.

Information screen display

E00524601117

Brake warning display

E00524701525



This warning is displayed if you drive with the parking brake still applied. The warning lamp in the instrument cluster only illuminates when the parking brake is applied.

CAUTION

- If a vehicle is driven without releasing the parking brake, the brake will be overheated, resulting in ineffective braking and possible brake failure.
If this warning is displayed, release the parking brake.



When the operation mode of the power switch is put in ON, if the brake fluid is low, this warning is displayed.

The warning lamp in the instrument cluster also illuminates.

CAUTION

- If this warning stays illuminated and does not go out while driving, there is a danger of ineffective braking. In this case, immediately park your vehicle in a safe place and we recommend you to have it checked.

CAUTION

- If the brake warning display is displayed and the brake warning lamp and the ABS warning lamp are illuminated at the same time, the braking force distribution function will not operate, so the vehicle may be destabilised during sudden braking. Avoid sudden braking and high-speed driving, stop the vehicle in a safe place, and we recommend you to have it checked.
 - The vehicle should be brought to a halt in the following manner when brake performance has deteriorated.
 - Depress the brake pedal harder than usual. Even if the brake pedal moves down to the very end of its possible stroke, keep it pressed down hard.
 - Should the brakes fail, use the regenerative brake to reduce your speed and keep pulling the Electric parking brake switch. (Refer to “Electric parking brake” on page 7-03)
- Depress the brake pedal to operate the stop lamp to alert the vehicles behind you.

Oil pressure warning display

E00524901309



If the engine oil pressure drops while the Plug-in Hybrid EV System is operating, the warning display is displayed on the information screen in the multi information display.

CAUTION

- If the vehicle is driven while the engine oil is low, or the oil level is normal but the warning is displayed, the engine may burn out and be damaged.
- If the warning is displayed while the Plug-in Hybrid EV System is operating, immediately park your vehicle in a safe place and check the engine oil level.
- If the warning is displayed while the engine oil level is normal, have it inspected.

Combination headlamps and dipper switch

E00506004732

Headlamps

NOTE

- When entering a country in which vehicles are driven on the opposite side of the road to the country in which your vehicles is supplied, necessary measures have to be taken to avoid dazzling oncoming traffic. However, headlamps on this vehicle do not need any adjustment.
- Do not leave the lights on for a long time while the Plug-in Hybrid EV System is stationary (not operating). A run-down auxiliary battery could result.
- When it rains, or when the vehicle has been washed, the inside of the lens sometimes becomes foggy, but this does not indicate a functional problem. When the lamp is switched on, the heat will remove the fog. However, if water gathers inside the lamp, we recommend you to have it checked.

OGGE19E1

Combination headlamps and dipper switch

Rotate the switch to turn on the lamps.

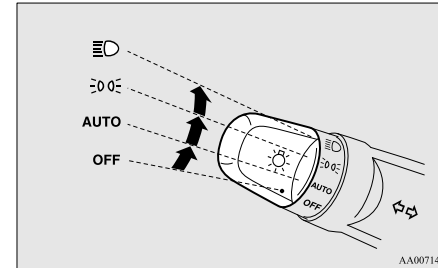

6

OFF	All lamps off {except daytime running lamps}
AUTO	When the operation mode of the power switch is ON, headlamps, position-, tail-, licence plate-, instrument panel lamps and down-light are turned on and off automatically in accordance with outside light level. {The daytime running lamps will go on while the tail lamps are off.} All lamps go off automatically when the operation mode is put in OFF.
	Position, tail, licence plate, instrument panel lamps and down-light on
	Headlamps and other lamps go on

Combination headlamps and dipper switch

NOTE

- The sensitivity of the automatic on/off control can be adjusted. For further information, contact a MITSUBISHI MOTORS Authorized Service Point.

On vehicles equipped with the Smartphone Link Display Audio or the MITSUBISHI Multi-Communication System (MMCS), screen operations can be used to make the adjustment.

Refer to the separate owner's manual for details.

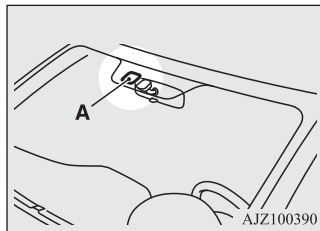

- When the headlamps are turned off by the automatic on/off control with the operation mode in ON, the front fog lamps and rear fog lamps also go off. When the headlamps are subsequently turned back on by the automatic on/off control, the front fog lamps also come on but the rear fog lamp stays off. If you wish to turn the rear fog lamp back on, operate the switch again.
- Do not cover the sensor (A) for the automatic on/off control by affixing a sticker or label to the windshield.



NOTE

- If the lamps do not turn on or off with the switch in the “AUTO” position, manually operate the switch and we recommend you to have your vehicle checked.

Lamps (headlamps, fog lamps, etc.) auto-cutout function

- If the operation mode of the power switch is put in OFF or ACC while the lamp switch is in the “ ” position, the lamps will turn off automatically when the driver's door is opened.
- If the operation mode of the power switch is put in OFF or ACC while the lamp switch is in the “ ” position, the lamps will remain on for about 3 minutes while the driver's door is shut and will then automatically turn off.

NOTE

- The lamp auto-cutout will not function when the lamp switch is in the “ ” position.



NOTE

- The lamp auto-cutout function can also be disabled.

For further information, we recommend you to consult a MITSUBISHI MOTORS Authorized Service Point.

On vehicles equipped with the Smartphone Link Display Audio or the MITSUBISHI Multi-Communication System (MMCS), screen operations can be used to make the adjustment. Refer to the separate owner's manual for details.

When you want to keep the lamps on:

1. Turn the lamp switch in the “OFF” position while the operation mode of the power switch is in OFF or ACC.
2. Turn on the lamps with the switch in the “ ” or “ ” position again, then the lamps will remain on.

LED headlamp warning lamp*

E00538101041

This warning lamp will illuminate when there is a fault in the LED headlamps. Also, “LED HEADLIGHT SERVICE REQUIRED” is displayed on the information screen in the multi information display for the driver.

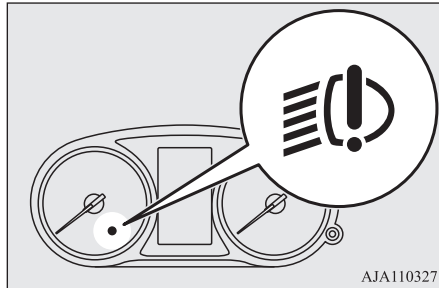

NOTE

- If the warning lamp illuminates, there may be a fault on the unit. Have the vehicle checked at a MITSUBISHI MOTORS Authorized Service Point.

Lamp monitor buzzer

E00506101631

If the driver's door is opened when the operation mode of the power switch is put in ACC or OFF with the lamps illuminated, a buzzer will sound to remind the driver to turn off the lamps.

The buzzer will automatically stop if the auto-cutoff function is activated, the lamp switch is turned off, or the door is closed.

Daytime running lamps

E00530601226

The daytime running lamps come on when the operation mode is ON and the lamp switch is in the “OFF” or “AUTO” position and the tail lamps are off.

NOTE

- If the lamp switch is in the “ D ” or “ D ” position, or if the tail lamps are on when the lamp switch is in the “AUTO” position, the daytime running lamps come on as position lamps.

Combination headlamps and dipper switch

Dipper (High/Low beam change)

E00506201557

When the lamp switch is in the “ D ” position, the beam changes from high to low (or low to high) each time the lever is pulled fully (1). While the high-beam is on, the high-beam indication lamp in the instrument cluster will also illuminate.

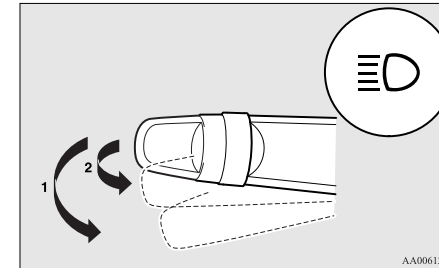

Headlamp flasher

E00506300199

The high-beams flash when the lever is pulled slightly (2), and will go off when it is released.

When the high-beam is on, the high-beam indication lamp in the instrument cluster will illuminate.

Combination headlamps and dipper switch

NOTE

- The high-beams can also flash when the lamp switch is OFF.
- If you turn the lamps off with the headlamps set to high-beam, the headlamps are automatically returned to their low-beam setting when the lamp switch is next turned to the “” position.

6

Automatic high-beam system*

E00538200117

The system switches the headlamp beams (high/low) when the sensor (A) senses an illuminant such as lights of a vehicle in front or oncoming vehicle or street lamp.

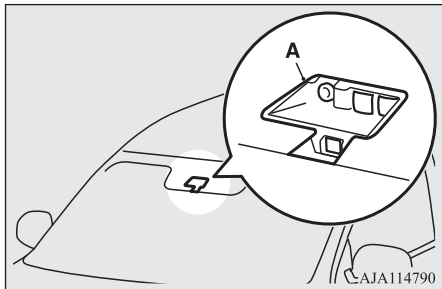

WARNING

- **The headlamp beams (high/low) may not be switched automatically under certain circumstances. Do not overestimate the system. It is the responsibility of the driver to switch the headlamp beams (high/low) manually to suit each driving condition.**
Refer to “Dipper (High/Low beam change)” on page 6-61

How to use the AHB

E00551500250

1. Rotate the lamp switch to the “” position or “AUTO” position when the Plug-in Hybrid EV System is operating.
2. Press the AHB switch.

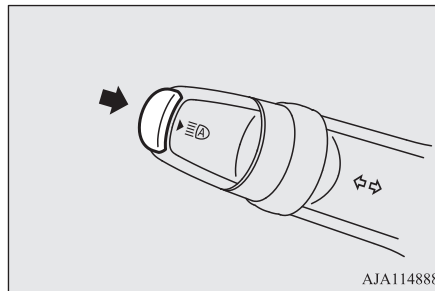

The AHB is activated and the indicator will illuminate.

If the AHB switch is pressed again, the AHB will be deactivated and the AHB indicator will go off.

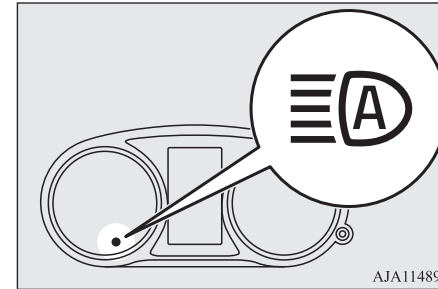

NOTE

- If the headlamps are on when the lamp switch is in the “AUTO” position, the AHB works.
- You can switch the headlamp beams (high/low) manually by operating the lever even if the AHB is working.
Refer to “Dipper (High/Low beam change)” on page 6-61
If the lever is operated manually, the AHB indicator will go off and the AHB will be deactivated.
Refer to “Manual switching” on page 6-62.
- The AHB is not deactivated when you pull the lever slightly (operation of the headlamp flasher).

Manual switching

Switching to low beam

1. Pull the lever towards you.
2. The AHB indicator will go off.
3. The AHB switch is pressed again, the AHB will activated.

Switching to high-beam

1. Pull the lever towards you.
2. The AHB indicator will go off and the high-beam indicator illuminates.
3. The AHB switch is pressed again, the AHB will activated.

Automatic switching conditions

E00551600059

The high-beam headlamps illuminate when all of the following conditions are met:

- Your vehicle speed exceeds approximately 40 km/h (25 mph).
- It is dark ahead of your vehicle.
- There are no vehicles in front or oncoming vehicles, or none of their exterior lamps are illuminated.

The low beam headlamps illuminate when any of the following conditions occur:

- Your vehicle speed does not exceed approximately 30 km/h (19 mph).
- It is bright ahead of your vehicle.
- An exterior lamp of a vehicle in front or oncoming vehicle is illuminating.

NOTE

- The headlamps may not be switched from high-beam to low beam under the following circumstances:
 - A vehicle in front or oncoming vehicle is hindered by any object such as continuous bends, elevated median/island, traffic signs, roadside trees.
 - Your vehicle passes an oncoming vehicle suddenly on a bend with poor visibility.
 - Another vehicle crosses ahead of your vehicle.
- The headlamps may remain at low beam (or be switched from high-beam to low beam) when a reflective object (e.g. street lamp, traffic signal, noticeboard and signboard) reflects light.
- Any of the following factors may influence the headlamp beam switching timing:
 - How brightly the exterior lamps of a vehicle in front or oncoming vehicle illuminate.
 - Movement or direction of a vehicle in front or oncoming vehicle.
 - Only right or left exterior lamp of a vehicle in front or oncoming vehicle is illuminating.
 - A vehicle in front or oncoming vehicle is a motorcycle.
 - Road conditions (gradient, bends and road surface).
 - The number of occupants and luggage load.

NOTE

- The AHB recognises environmental conditions by sensing a light source ahead of your vehicle. Therefore, you may feel like something is not quite right when the headlamp beams are switched automatically.
- The system may not detect a light vehicle such as a bicycle.
- The system may not detect an ambient brightness precisely. This causes the traffic to be dazzled by high-beam or the low beam to be maintained. In such cases, you should switch the headlamp beams manually.
 - In bad weather (heavy rain, fog, snow or sandstorm).
 - The windscreen is dirty or fogged up.
 - The windscreen is cracked or broken.
 - The sensor is deformed or dirty.
 - A light that is similar to the headlamps or tail lamps is shining around your vehicle.
 - A vehicle in front or oncoming vehicle is driven without lights, the exterior lamps are dirty or discoloured, or the direction of the headlamp beams is adjusted improperly.
 - It becomes dark and bright suddenly and continuously around your vehicle.
 - Your vehicle is driven on uneven surfaces.
 - Your vehicle is driven on a winding road.
 - A reflective object such as a noticeboard or a mirror reflects a light ahead of your vehicle.

Combination headlamps and dipper switch

NOTE

- When lamps of the vehicle in front or headlamps of an oncoming vehicle blend into the other lamps.
- The rear end of a vehicle in front (such as a container truck) reflect a strong light.
- Your vehicle's headlamp is broken or dirty.
- Your vehicle is inclined due to a flat tyre or towing.
- The warning display appears.
(Refer to "System problem warning" on page 6-64.)
- Observe the precautions below to maintain good usage conditions:
 - Do not attempt to disassemble the sensor.
 - Do not affix a sticker or label on the windscreen near the sensor.
 - Avoid overload.
 - Do not modify your vehicle.
 - When the windscreen is replaced, use the MITSUBISHI MOTORS GENUINE parts.

System problem warning

E00551700063

If a problem occurs with the system, the following warning display will appear to the type of the problem.

The AHB deactivation due to fault

If a failure is detected in the system, the following warning display will appear and the AHB will automatically be turned off.

6-64 Instruments and controls

If the warning display remains even after the operation mode of the power switch is put in OFF and then turned back to ON, please contact a MITSUBISHI MOTORS Authorized Service Point.

[When the AHB is malfunctioning]



[When the sensor is malfunctioning]



NOTE

- If the sensor or its surrounding area reaches an extremely high temperature when parking the vehicle under a blazing sun, the "AHB SERVICE REQUIRED" warning display may appear.
If the warning display remains even after the temperature of the sensor or its surrounding area has been in range, please contact a MITSUBISHI MOTORS Authorized Service Point.

Sensor is too hot or cold

If the system becomes temporarily unavailable due to a high or low temperature of the sensor, the following warning display will appear.

After the temperature of the sensor has been in range, the system will automatically return to operation.

If the warning display does not disappear after waiting for a while, there is a possibility that the AHB has a malfunction. Contact a MITSUBISHI MOTORS Authorized Service Point for inspection of the system.



Windscreen is dirty

If the AHB determines that its performance has been degraded, the warning display will appear.

This can occur when:

- Foreign objects, such as dirt, snow or ice, adhere to the windscreen of the sensor portion.
- There are adverse weather conditions, such as rain, snow, sand storms, etc.
- A vehicle in front or an oncoming vehicle is splashing water, snow or dirt.

OGGE19E1

When the sensor performance returns, the AHB will resume operation.
If the warning display does not disappear after waiting for a while, there is a possibility that the sensor has a malfunction. Contact a MITSUBISHI MOTORS Authorized Service Point for inspection of the sensor.



Welcome light

E00528902072

This function turns on the position and tail lamps for about 30 seconds after the UNLOCK switch on the remote control transmitter is pressed when the combination headlamps and dipper switch is in the “OFF” or “AUTO” position. The welcome light function will operate only when it is dark outside the vehicle.

NOTE

- While the welcome light function is operating, perform one of the following operations to cancel the function.
 - Push the LOCK switch on the remote control transmitter.

NOTE

- Turn the combination headlamps and dipper switch to the “OFF” or “AUTO” position.
- Put the operation mode of the power switch in ON.
- It is possible to modify functions as follows:
 - The headlamps can be set to come on in the low beam setting.
 - The welcome light function can be deactivated.

For further information, please contact your MITSUBISHI MOTORS Authorized Service Point.

On vehicles equipped with the Smartphone Link Display Audio or the MITSUBISHI Multi-Communication System (MMCS), screen operations can be used to make the adjustment. Refer to the separate owner’s manual for details.

Coming home light

E00529001826

This function turns on the headlamps in the low beam setting for about 30 seconds after the operation mode is put in OFF.

1. Turn the combination headlamps and dipper switch to the “OFF” or “AUTO” position.
2. Put the operation mode of the power switch in OFF.

Combination headlamps and dipper switch

3. Within 60 seconds of putting the operation mode in OFF, pull the turn signal lever towards you.

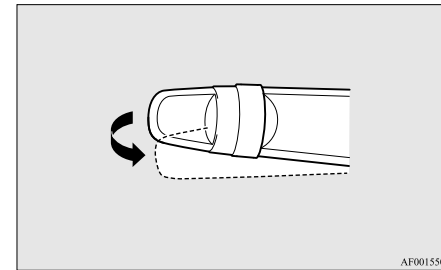

6

4. The headlamps will come on in the low beam setting for about 30 seconds. After the headlamps go off, the headlamps can be turned on again in the low beam setting for about 30 seconds by pulling the turn signal lever towards you within 60 seconds of putting the operation mode in OFF.



To turn on the headlamps again after 60 seconds of putting the operation mode in OFF, repeat the process from step 1.

NOTE

- While the coming home light function is operating, perform one of the following operations to cancel the function.

Headlamp levelling

NOTE

- Pull the lever towards you.
- Turn the combination headlamps and dipper switch to the “” or “” position.
- Put the operation mode in ON.
- It is possible to modify functions as follows:
 - The time that the headlamps remain on can be changed.
 - The coming home light function can be deactivated.

For further information, please contact your MITSUBISHI MOTORS Authorized Service Point.

On vehicles equipped with the Smartphone Link Display Audio or the MITSUBISHI Multi-Communication System (MMCS), screen operations can be used to make the adjustment. Refer to the separate owner’s manual for details.

Headlamp levelling

E00517400031

Headlamp levelling switch (except for vehicle with LED headlamps)

E00517502023

The angle of the headlamp beam varies depending on the load carried by the vehicle.

The headlamp levelling switch can be used to adjust the headlamp illumination distance (when the lower beam is illuminated) so that the headlamps’ glare does not distract other drivers.
Set the switch according to the following table.

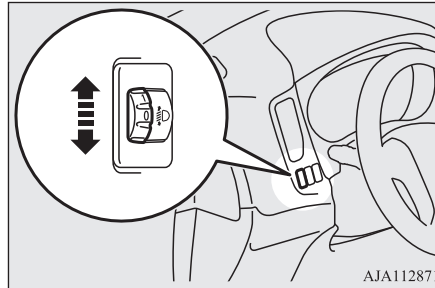





AJA112871

CAUTION

- Always perform adjustments before driving. Do not attempt to adjust while driving, as it could cause an accident.

Vehicle condition	Switch position
	“0”

Vehicle condition	Switch position
	“0”
	“1”
	“2”
	“2”

●: 1 person

: Full luggage loading

Switch position Driver only/Driver + 1
0- front passenger

Switch position 5 passengers (including
1- driver)

Switch position 5 passengers (including
2- driver) + Full luggage loading/Driver + Full luggage loading

Automatic headlamp levelling (vehicles with LED headlamps)

E00517601652

This mechanism automatically adjusts the direction of the headlamps (beam position) depending on changes in the condition of the vehicle, such as the number of occupants or luggage weight. When the headlamps are illuminated with the operation mode of the power switch in ON, the beam position of the headlamps is automatically adjusted when the vehicle stops.

Turn-signal lever

E00506502948

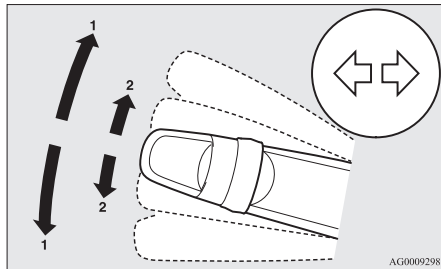

AG0009298

1- Turn-signals

When making a normal turn, use position (1). The lever will return automatically when cornering is completed.

2- Lane-change signals

When moving the lever to (2) slightly to change a lane, the turn-signal lamps and indication lamp in the instrument cluster will only flash while the lever is operated.

Also, when you move the lever to (2) slightly then release it, the turn-signal lamps and indication lamp in the instrument cluster will flash 3 times.

NOTE

- If the lamp flashes unusually quickly, the bulb in a turn-signal lamp may have burned out. We recommend you to have the vehicle inspected.
- It is possible to activate the following functions.
 - Flashing of the turn-signal lamps when the lever is operated with the operation mode is in ACC.
 - Deactivate the turn-signal lamp 3-flash function for lane changes.
 - The time required to operate the lever for the 3-flash function can be adjusted.

For further information, we recommend you to consult a MITSUBISHI MOTORS Authorized Service Point.

On vehicles equipped with the Smartphone Link Display Audio or the MITSUBISHI Multi-Communication System (MMCS), screen operations can be used to make the

NOTE

adjustment. Refer to the separate owner's manual for details.

- It is possible to change the tone of a sounding buzzer as the turn-signal lamps flash. Refer to "Changing the turn-signal sound" on page 6-22.

Hazard warning flasher switch

E00506602457

6

Use the hazard warning flasher switch when the vehicle has to be parked on the road for any emergency.

The hazard warning flashers can always be operated, regardless of the operation mode. Push the switch to turn on the hazard warning flashers, all turn-signal lamps flash continuously. To turn them off, push the switch again.

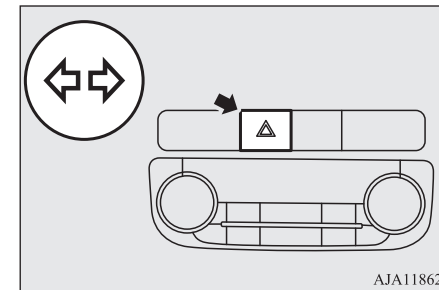

AJA118626

ECO mode switch

NOTE

- If the switch is used for a long period while the ready indicator is not illuminated, the auxiliary battery could go flat and the Plug-in Hybrid EV System could be impossible to start.
- While the hazard warning lamps are blinking due to having manually pushed the switch, the emergency stop signal system does not operate.
Refer to “Emergency stop signal system” on page 7-39.

6

ECO mode switch

E00531801270

ECO mode is an eco-driving support system which automatically controls the Plug-in Hybrid EV System and air conditioning system to improve fuel efficiency.

When the ECO mode is active, your vehicle will slowly accelerate even when you press the accelerator pedal.

Refer to “Automatic climate control air conditioner” on page 8-06.

The ECO mode starts working by pressing the ECO mode switch when the operation mode of the power switch is in ON. Push the switch again and the ECO mode will cancel.

While the ECO mode is working, an ECO mode indicator will be turned on.

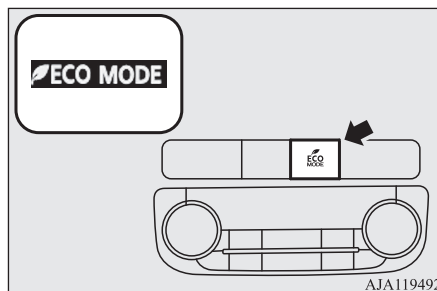

NOTE

- Even if the ECO mode is selected, after turning the operation mode of the power switch OFF and turning to ON again, the ECO mode is set to OFF.
- Even if the ECO mode is operating, you can select normal operation of the air conditioner.

For further information, we recommend you to consult a MITSUBISHI MOTORS Authorized Service Point.

On vehicles equipped with the Smartphone Link Display Audio or the MITSUBISHI Multi-Communication System (MMCS), it is possible to change the setting by means of screen operations.

Refer to the separate owner's manual for details.

Fog lamp switch

E00506700034

Front fog lamp switch

E00508301754

The front fog lamps can be operated while the headlamps or tail lamps are on. Turn the knob in the “ON” direction to turn on the front fog lamps. An indication lamp in the instrument cluster will also come on. Turn the knob in the “OFF” direction to turn off the front fog lamps. The knob will automatically return to its original position when you release it.

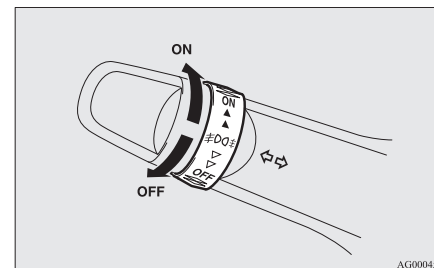

NOTE

- The front fog lamps are automatically turned off when the headlamps or tail lamps are turned off. To turn the front fog lamps on again, turn the knob in the “ON” direction after turning on the headlamps or tail lamps.
- Do not use fog lamps except in conditions of fog, otherwise excessive lamp glare may temporarily blind oncoming vehicle drivers.

Rear fog lamp switch

E00508401625

The rear fog lamp can be operated when the headlamps or front fog lamps turn on. An indication lamp in the instrument cluster comes on when the rear fog lamp is turned on.

Turn the knob once in the “ON” direction to turn on the front fog lamps. Turn the knob once more in the “ON” direction to turn on the rear fog lamp. To turn the rear fog lamp off, turn the knob once in the “OFF” direction. Turn the knob once more in the “OFF” direction to turn off the front fog lamps. The knob will automatically return to its original position when you release it.

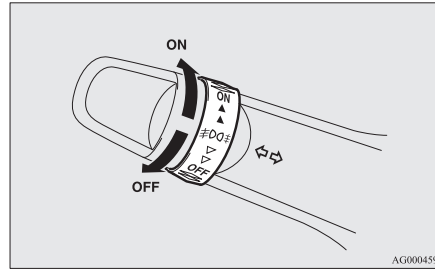

AG0004596

NOTE

- The rear fog lamp is automatically turned off when the headlamps or front fog lamps are turned off.
- To turn the rear fog lamp on again, turn the knob twice in the “ON” direction after turning on the headlamps.

Wiper and washer switch

E00507101218

CAUTION

- If the washer is used in cold weather, the washer fluid sprayed against the glass may freeze, which may hinder visibility. Warm the glass with the defroster or rear window demister before using the washer.

6

Windscreen wipers

E00516901980

NOTE

- To ensure a clear rearward view, the rear window wiper will automatically perform several continuous operations if the selector lever is put in the “R” position while the windscreen wipers are operating. Refer to “Rear window wiper and washer” on page 6-72.

The windscreen wipers can be operated with the operation mode of the power switch in ON or ACC.

Wiper and washer switch

If the blades are frozen to the windscreen or rear window, do not operate the wipers until the ice has melted and the blades are freed, otherwise the wiper motor may be damaged.

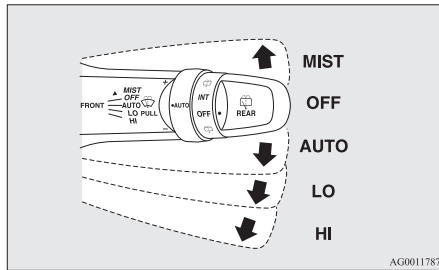

MIST-	Misting function The wipers will operate once.
OFF-	Off
AUTO-	Auto-wiper control Rain sensor The wipers will automatically operate depending on the degree of wetness on the windscreen.
LO-	Slow
HI-	Fast

Rain sensor

Can only be used when the ignition switch or the operation mode is in ON.

6-70 Instruments and controls

If the lever is put in the “AUTO” position, the rain sensor (A) will detect the extent of rain (or snow, other moisture, dust, etc.) and the wipers will operate automatically. Keep the lever in the “OFF” position if the windscreen is dirty and the weather is dry. Wiper operation under these conditions can scratch the windscreen and damage the wipers.

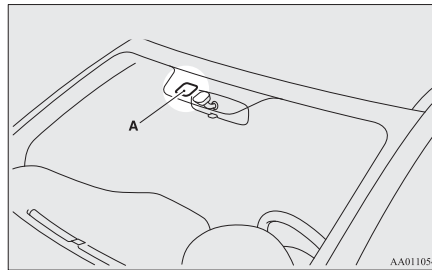

CAUTION

- With the ignition switch or the operation mode in ON and the lever in the “AUTO” position, the wipers may automatically operate in the situations described below. If your hands get trapped, you could suffer injuries or the wipers could malfunction. Be sure to put the operation mode in OFF, or move lever to the “OFF” position to deactivate the rain sensor.
 - When cleaning the outside surface of the windscreen, if you touch on top of the rain sensor.

OGGE19E1

CAUTION

- When cleaning the outside surface of the windscreen, if you wipe with a cloth on top of the rain sensor.
- When using an automatic car wash.
- A physical shock is applied to the windscreen.
- A physical shock is applied to the rain sensor.

NOTE

- To protect the rubber parts of the wipers, this operation of the wipers does not take place even if the lever is put in the “AUTO” position when the vehicle is stationary and the ambient temperature is about 0 °C or lower.
- Do not cover the sensor by affixing a sticker or label to the windscreen. Also, do not put any water-repellent coating on the windscreen. The rain sensor would not be able to detect the extent of rain, and the wipers might stop working normally.
- In the following cases, the rain sensor may be malfunctioning. For further information, we recommend you to consult a MITSUBISHI MOTORS Authorized Service Point.
 - When the wipers operate at a constant interval despite changes in the extent of rain.
 - When the wipers do not operate even though it is raining.

NOTE

- The wipers may automatically operate when things such as insects or foreign objects are affixed to the windscreen on top of the rain sensor or when the windscreen is frozen. Objects affixed to the windscreen will stop the wipers when the wipers cannot remove them. To operate the wipers again, move the lever in the “LO” or “HI” position. Also, the wipers may operate automatically due to strong direct sunlight or electromagnetic wave. To stop the wipers, place the lever in the “OFF” position.
- Contact a MITSUBISHI MOTORS Authorized Service Point when replacing the windscreen or reinforcing the glass around the sensor.

To adjust the sensitivity of the rain sensor

With the lever in the “AUTO” (rain sensor) position, it is possible to adjust the sensitivity of the rain sensor by turning the knob (B).

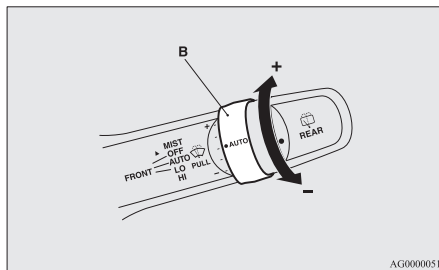

- “+”- Higher sensitivity to rain
- “-”- Lower sensitivity to rain

NOTE

- It is possible to activate the following functions.
 - Automatic operation (rain droplet sensitive) can be changed to intermittent operation (vehicle-speed sensitive).
 - Automatic operation (rain droplet sensitive) can be changed to intermittent operation (except vehicle-speed sensitive).

For further information, we recommend you to consult a MITSUBISHI MOTORS Authorized Service Point.

On vehicles equipped with the Smartphone Link Display Audio or the MITSUBISHI Multi-Communication System (MMCS), screen operations can be used to make the adjustment. Refer to the separate owner's manual for details.

Misting function

Move the lever in the direction of the arrow and release, to operate the wipers once. Use this function when you are driving in mist or drizzle.

Wiper and washer switch

The wipers will operate once if the lever is raised to the “MIST” position and released when the ignition switch or the operation mode is in the “ON” or “ACC” position. The wipers will continue to operate while the lever is held in the “MIST” position.

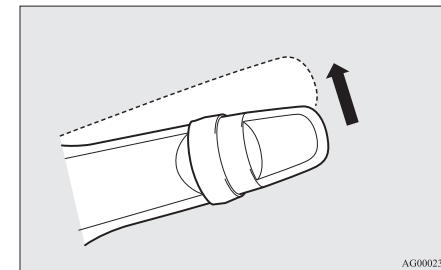

6

The wipers will operate once if the lever is moved to the “AUTO” position and the knob (C) is turned in the “+” direction when the ignition switch is in the “ON” position.

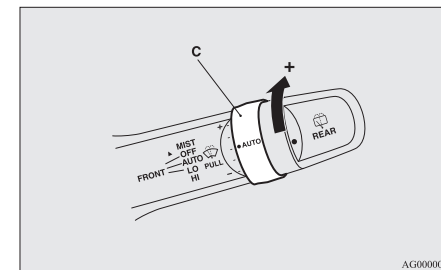

Wiper and washer switch

Windscreen washer

E00507202665

The windscreen washer can be operated with the operation mode of the power switch in ON or ACC.

The washer fluid will be sprayed onto the windscreen by pulling the lever towards you. When the wipers are not in operation or in intermittent operation, by pulling the lever towards you, the wipers will operate several times while the washer fluid is being sprayed. Then about 6 seconds later, wipers operate once more.

On vehicles equipped with a headlamp washer, while the headlamps are on, the headlamp washer will operate once together with the windscreen washer.

Also, by releasing the lever soon after pulling it towards you, the washer fluid will be sprayed several times while the wipers are operating several times. (Intelligent washer) Then about 6 seconds later, wipers operate once more.

6

Intelligent washer will stop operating with any operation of the lever.

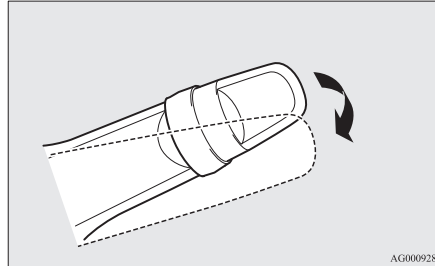

AG0009285

CAUTION

- If the washer is used in cold weather, the washer fluid sprayed against the glass may freeze resulting in poor visibility. Heat the glass with the defroster or demister before using the washer.

NOTE

- It is possible to modify functions as follows:
 - Causing the wiper never to operate when washer fluid is sprayed.
 - Deactivating the intelligent washer.
 - Deactivating the function that operates the wipers once more about 6 seconds later.
- For further information, we recommend you to consult a MITSUBISHI MOTORS Authorized Service Point.

NOTE

On vehicles equipped with the Smartphone Link Display Audio or the MITSUBISHI Multi-Communication System (MMCS), screen operations can be used to make the adjustment. Refer to the separate owner's manual for details.

Rear window wiper and washer

E00507302536

The rear window wiper and washer switch can be operated with the operation mode of the power switch in ON or ACC.

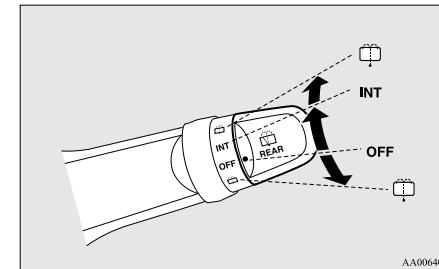

AA0064046

INT- The wiper operates continuously for several seconds then operates intermittently at intervals of about every 8 seconds

OFF- Off



The washer fluid will be sprayed onto the rear window when the knob is turned fully in either direction.

The wipers operate automatically several times while the washer fluid is being sprayed.

NOTE

- The rear window wiper will automatically perform several continuous operations if the selector lever is put in the “R” position while the windscreen wipers or the rear window wiper is operating. (automatic operation mode)

After the automatic operation, the rear window wiper will stop operating if the knob is in the “OFF” position. If the knob is in the “INT” position, the rear window wiper will return to the intermittent operation.

It is possible to set the rear window wiper to perform the automatic operation only if the selector lever is put in the “R” position while the rear window wiper is operating with the knob in the “INT” position.

For further information, we recommend you to consult a MITSUBISHI MOTORS Authorized Service Point.

On vehicles equipped with the Smartphone Link Display Audio or the MITSUBISHI Multi-Communication System (MMCS), screen operations can be used to make the adjustment.

Refer to the separate owner’s manual for details.

- If the knob is in the “OFF” position, turn the knob to the “INT” position twice quickly to operate the rear window wiper continuously. (continuous operation mode)
Turn the knob to the “OFF” position to stop the rear window wiper continuous operation.

NOTE

- The interval for intermittent operation can be adjusted.

For further information, we recommend you to consult a MITSUBISHI MOTORS Authorized Service Point.

On vehicles equipped with the Smartphone Link Display Audio or the MITSUBISHI Multi-Communication System (MMCS), screen operations can be used to make the adjustment. Refer to the separate owner’s manual for details.

6

Headlamp washer switch

E00510101658

The headlamp washer can be operated with the operation mode in ON or ACC and the lamp switch at the “ ” position.

Push the button once and the washer fluid will be sprayed on to the headlamps.

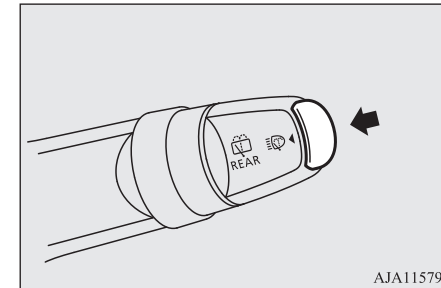

AJA115797

Wiper de-icer switch*

NOTE

- If the operation mode is in ON or ACC and the headlamps are on, the headlamp washer operates together with the windscreen washer the first time the windscreen washer lever is pulled.

6

Precautions to observe when using wipers and washers

E00507601327

- If the moving wipers become blocked partway through a sweep by ice or other deposits on the glass, the wipers may temporarily stop operating to prevent the motor from overheating. In this case, park the vehicle in a safe place, put the operation mode in OFF, and then remove the ice or other deposits.
The wipers will start operating again after the wiper motor cools down, so check that the wipers operate before using them.
- Do not use the wipers when the glass is dry.
They may scratch the glass surface and the blades wear out prematurely.
- Before using the wipers in cold weather, check that the wiper blades are not frozen onto the glass. The motor may burn out if the wipers are used with the blades frozen onto the glass.

- Avoid using the washer continuously for more than 20 seconds. Do not operate the washer when the fluid reservoir is empty.
Otherwise, the motor may burn out.
- Periodically check the level of washer fluid in the reservoir and refill if required.
During cold weather, add a recommended washer solution that will not freeze in the washer reservoir. Failure to do so could result in loss of washer function and frost damage to the system components.

Wiper de-icer switch*

E00507701142

The rear window demister switch can be operated when the Plug-in Hybrid EV System is operating.

When the front wipers have frozen to the windscreen at the parked positions, turning on this switch will heat the windscreen to make the wipers operable. Press the rear window demister switch and the deicer will operate.

NOTE

- The wiper de-icer is activated/deactivated, depending on the operation of the rear window demister. Refer to “Rear window demister switch” on page 6-74.

Rear window demister switch

E00507902659

The rear window demister switch can be operated when the operation mode of the power switch is in ON.

Push the switch to turn on the rear window demister. It will be turned off automatically in about 15 to 20 minutes depending on the outside temperature. To turn off the demister while it is operating, push the switch again. The indication lamp (A) will illuminate while the demister is on.

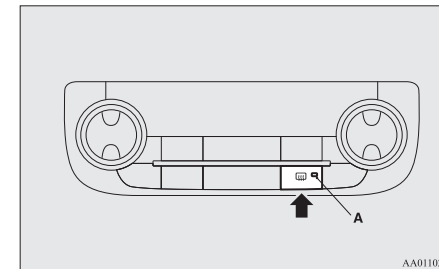

Heated windscreen switch*

NOTE

- Do not use this switch when the ready indication lamp is not illuminated. The auxiliary battery could go flat, making it impossible to start the Plug-in Hybrid EV System.
- Since the demister requires a significant amount of power, stop the demister as soon as the window is demisted. Using it for a long time may reduce the auxiliary battery voltage, making it impossible to start the Plug-in Hybrid EV System.
- When the rear window demister switch is pressed, the outside rear-view mirrors are defogged or defrosted. Refer to “Heated mirror” on page 7-10.
- On vehicles equipped with the wiper de-icer, when the rear window demister switch is pushed, the window glass becomes warm and the wipers become operable. Refer to “Wiper de-icer switch” on page 6-74.

NOTE

- It is possible to change the setting to make the rear window demister operate automatically when ambient temperature becomes low while the ready indication lamp is illuminated, even if you do not push the rear window demister switch.
It operates automatically only once after putting the operation mode in ON.
If you choose this setting, the heated mirrors (if so equipped) and wiper de-icer (if so equipped) will also operate automatically at the same time.
For further information, we recommend you to consult a MITSUBISHI MOTORS Authorized Service Point.
On vehicles equipped with the Smartphone Link Display Audio or the MITSUBISHI Multi-Communication System (MMCS), screen operations can be used to make the adjustment. Refer to the separate owner’s manual for details.
- The demister switch is not to melt snow but to clear mist. Remove snow before use of the demister switch.
- When cleaning the inside of the rear window, use a soft cloth and wipe gently along the heater wires, being careful not to damage the wires.
- Do not allow objects to touch the inside of the rear window glass, damaged or broken wires may result.

Heated windscreen switch*

E0053200054

In cold weather windscreen can be heated by electrical-heat units.

It will speed-up removal of frost and condensate.

The heated windscreen switch can be operated when the Plug-in Hybrid EV System is operating and the outside temperature is about 5 °C or less.

Push the switch to turn on the heated windscreen. It will be turned off automatically in about 5 to 10 minutes depending on the outside temperature. To turn off the heated windscreen while it is operating, push the switch again.

The indication lamp (A) will illuminate while the heated windscreen is on.

6

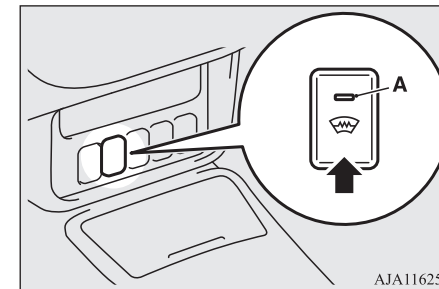

Heated steering wheel switch*

⚠ CAUTION

- While heated windscreen is operating, the outer surface of the windscreen will be hot. Do not touch the windscreen to prevent burns.

📖 NOTE

6

- Remove snow before use of the heated windscreen. It is not possible to melt large amount of accumulated snow by the heated windscreen.
- To avoid the battery runs out, do not use the heated windscreen continuously.

Heated steering wheel switch*

E00532100042

The heated steering wheel will warm the grip portions of the left and right on the steering wheel by internal heater.

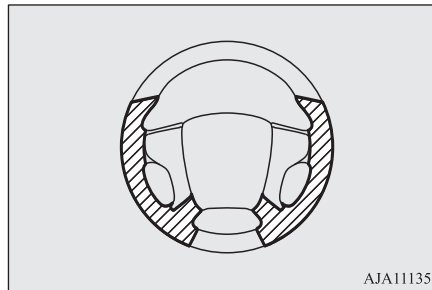

 Heating range

The heated steering wheel can be operated when the operation mode of the power switch is in ON.

Push the switch to turn on the heated steering wheel. It will be turned off automatically in about 30 minutes. To turn off the heated steering wheel while operating, push the switch again.

The indication lamp (A) will illuminate while the heated steering wheel is on.

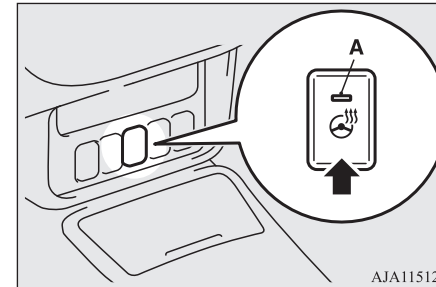

⚠ CAUTION

- If the following types of persons use the heated steering wheel, they might become too hot or receive minor burns (red skin, heat blisters, etc.):
 - Elderly or ill people.
 - People with sensitive skin.
 - Excessively tired people.
 - People under the influence of sleep inducing medication (cold medicine, etc.).
- If water or any other liquid is spilled on the steering wheel, allow it to dry thoroughly before attempting to use the heated steering wheel. Turn the heated steering wheel off immediately if it appears to be malfunctioning during use.

⚠ CAUTION

- Long use of the heated steering wheel when the ready indicator is not illuminated may run down the auxiliary battery.

Horn switch

E00508001735

Press the steering wheel on or around the “” mark.

6

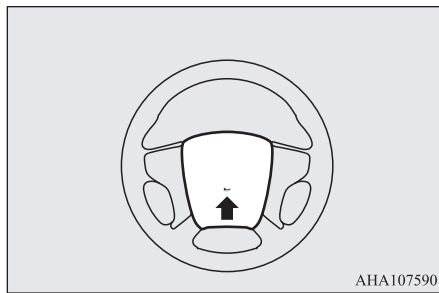

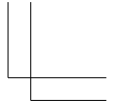
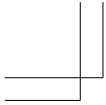

Handwriting practice lines consisting of 12 horizontal dashed lines.

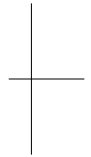
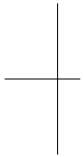

OGGE19E1

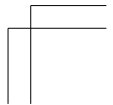
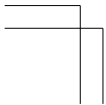

Starting and driving

Economical driving.....	7-02	Active stability control (ASC).....	7-43
Driving, alcohol and drugs.....	7-02	Cruise control*.....	7-45
Safe driving techniques.....	7-02	Speed Limiter*.....	7-50
Parking brake.....	7-03	Adaptive Cruise Control System (ACC)*.....	7-55
Parking.....	7-06	Forward Collision Mitigation System (FCM)*.....	7-67
Steering wheel height and reach adjustment.....	7-07	Ultrasonic misacceleration Mitigation System (UMS)*.....	7-77
Inside rear-view mirror.....	7-07	Blind Spot Warning (BSW) (with Lane Change Assist)*.....	7-82
Outside rear-view mirrors.....	7-09	Rear Cross Traffic Alert (RCTA)*.....	7-86
Power switch.....	7-11	Lane Departure Warning (LDW)*.....	7-88
Starting and stopping the Plug-in Hybrid EV System.....	7-13	Tyre pressure monitoring system (TPMS).....	7-92
Selector lever (Joystick type).....	7-15	Reversing sensor system*.....	7-97
Select position indicator.....	7-17	Parking sensors (Front/Rear)*.....	7-101
Electrical Parking switch.....	7-18	Rear-view camera*.....	7-105
Regenerative braking level selector (paddle type)*.....	7-19	Multi Around Monitor*.....	7-109
S-AWC (Super All Wheel Control).....	7-20	Cargo loads.....	7-117
4-wheel drive operation.....	7-23	Trailer towing.....	7-118
Inspection and maintenance following rough road operation.....	7-24		
Cautions on handling of 4-wheel drive vehicles.....	7-25		
EV switch.....	7-25		
SAVE/CHARGE mode switch.....	7-28		
SPORT mode switch.....	7-31		
Acoustic Vehicle Alerting System (AVAS).....	7-32		
Braking.....	7-34		
Brake auto hold.....	7-35		
Hill start assist.....	7-37		
Brake assist system.....	7-39		
Emergency stop signal system.....	7-39		
Anti-lock brake system (ABS).....	7-40		
Electric power steering system (EPS).....	7-42		

Economical driving

Economical driving

E00600102422

For economical driving, there are some technical requirements that have to be met. The prerequisite for low fuel consumption is a properly adjusted engine. In order to achieve longer life of the vehicle and the most economical operation, we recommend you to have the vehicle checked at regular intervals in accordance with the service standards.

7

Fuel economy and generation of exhaust gas and noise are highly influenced by personal driving habits as well as the particular operating conditions. The following points should be observed in order to minimize wear of brakes, tyres and engine as well as to reduce environmental pollution.

Starting and acceleration

Avoid driving when the accelerator pedal is pressed way down, such as for unnecessarily sudden starts, acceleration and deceleration. Smoothly depress the accelerator pedal. Observe the speed limit and keep the speed as constant as possible while driving.

Idling

Parking for a long period with the ready indicator illuminated will shorten the cruising range.

7-02 Starting and driving

Speed

The higher the vehicle speed, the more drive battery is consumed. Avoid driving at full speed. Even a slight release of the accelerator pedal will save a significant amount of drive battery.

Tyre inflation pressure

Check the tyre inflation pressures at regular intervals. Low tyre inflation pressure increases road resistance and fuel consumption. In addition, low tyre pressures adversely affect tyre wear and driving stability.

Cargo loads

Do not drive with unnecessary articles in the luggage compartment. Especially during city driving where frequent starting and stopping is necessary, the increased weight of the vehicle will greatly affect fuel consumption. Also avoid driving with unnecessary luggage or carriers, etc., on the roof; the increased air resistance will increase fuel consumption.

Air conditioning

Too much cooling/heating can affect the cruising range, so maintain an appropriate temperature to extend the cruising range.

Driving, alcohol and drugs

E00600200070

Driving after drinking alcohol is one of the most frequent causes of accidents.

Your driving ability can be seriously impaired even with blood alcohol levels far below the legal minimum. If you have been drinking, don't drive. Ride with a designated non-drinking driver, call a cab or a friend, or use public transportation. Drinking coffee or taking a cold shower will not make you sober.

Similarly, prescription and nonprescription drugs affect your alertness, perception and reaction time. Consult with your doctor or pharmacist before driving while under the influence of any of these medications.

⚠ WARNING

- **NEVER DRINK AND DRIVE.**
Your perceptions are less accurate, your reflexes are slower and your judgment is impaired.

Safe driving techniques

E00600301775

Driving safety and protection against injury cannot be fully ensured. However, we recommend that you pay extra attention to the following:

OGGE19E1

Seat belts

Before starting the vehicle, make sure that you and your passengers have fastened your seat belts.

Floor mats

WARNING

- Keep floor mats clear of the pedals by correctly laying floor mats that are suitable for the vehicle.
To prevent the floor mats from slipping out of position, securely retain them using the hook etc.
Note that laying a floor mat over a pedal or laying one floor mat on top of another can obstruct pedal operation and lead to a serious accident.

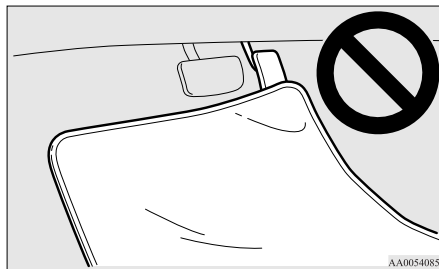

AA0054085

Carrying children in the vehicle

- Never leave your vehicle unattended with the key and children inside the vehicle. Children may play with the driving controls and this could lead to an accident.
- Make sure that infants and small children are properly restrained in accordance with the laws and regulations, and for maximum protection in case of an accident.
- Prevent children from playing in the luggage compartment. It is quite dangerous to allow them to play there while the vehicle is moving.

Loading luggage

When loading luggage, be careful not to load above the height of seats. This is dangerous not only because rearward vision will be obstructed, but also the luggage may be projected into the passenger compartment under hard braking.

Parking brake

E00600502918

To park the vehicle, first bring it to a complete stop, fully apply the parking brake sufficiently to hold the vehicle.

OGGE19E1

Make sure the brake warning lamp (red) is illuminated.

Electric parking brake

E00642100222

The Electric parking brake is the system that applies the parking brake by the electric motor.

NOTE

- You may hear an operation noise from the vehicle body when operating the Electric parking brake. This does not indicate a malfunction and the Electric parking brake is operating normally.
- When the auxiliary battery is weak or dead, the Electric parking brake cannot be applied or released. Refer to “Emergency starting” on page 9-02.
- You may feel the brake pedal moving when operating the Electric parking brake. This does not indicate a malfunction.

Parking brake

To apply

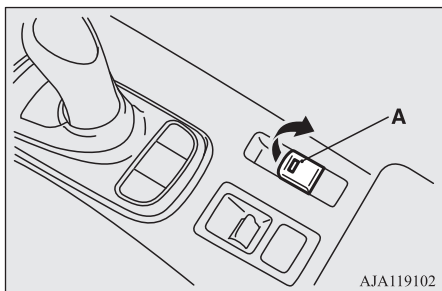

7

1. Stop the vehicle completely.
2. Pull up the Electric parking brake switch while depressing the brake pedal.

When the parking brake is applied, the brake warning lamp (red) in the instrument cluster and the indication lamp (A) on the Electric parking brake switch will come on.

CAUTION

- While the vehicle is in motion, do not apply the Electric parking brake. Doing so may cause overheating and/or premature wear of brake parts, reducing brake performance.

NOTE

- In the following conditions, the brake warning lamp (red) will illuminate for approximately 15 seconds and then go off.
 - While the Electric parking brake is applied, the operation mode of the power switch is put in OFF.
 - While the operation mode of the power switch is in OFF, the Electric parking brake switch is pulled up.
- If the Electric parking brake must be applied in an emergency situation, pull and hold the Electric parking brake switch to apply the Electric parking brake. At that time, the following warning display will appear in the multi-information display and a buzzer will sound, however you should continue to pull and hold the Electric parking brake switch.



- When parking on steep grades, pull up the Electric parking brake switch twice (once more after the operation is completed once). The maximum effect of the parking brake will be obtained.
- If the parking brake does not hold the vehicle stationary after the foot brake is released, contact a MITSUBISHI MOTORS Authorized Service Point.

NOTE

- When the operation mode of the power switch is other than ON, if the Electric parking brake is applied, the Electric parking brake indication lamp comes on for a while.
- If the Electric parking brake switch is repeatedly operated in a short time, the following warning display will appear in the multi-information display and the Electric parking brake will temporarily stop working. In such case, wait for approximately 1 minute until the warning display disappears, and operate the Electric parking brake switch again.



- The brake warning lamp (red) and the indication lamp on the Electric parking brake switch may blink. This does not indicate a malfunction, the lamps go off when/if the Electric parking brake is released.
- Depending on the situation, the Electric parking brake may be applied automatically. Refer to "Brake auto hold" on page 7-35.

To release

Manual operation

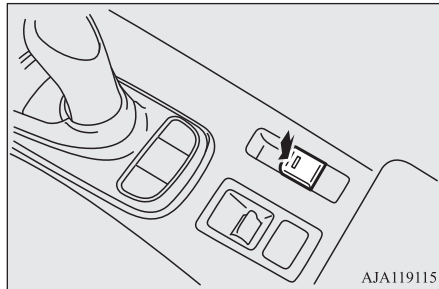

1. Make sure that the operation mode of the power switch is ON.
2. Press down the Electric parking brake switch while depressing the brake pedal.

Automatic operation

When the accelerator pedal is depressed slowly while all of the following conditions are met, the Electric parking brake is automatically released.

- The Plug-in Hybrid EV System is operating.
- The select position is in the “D” (DRIVE) or the “R” (REVERSE) position.
- The driver’s seat belt is fastened.

When the parking brake is released, the brake warning lamp (red) and the indication lamp on the Electric parking brake switch go off. Before driving, be sure that the Electric parking brake is released and the brake warning lamp is off.

CAUTION

- After the Electric parking brake switch has been operated to apply or release the Electric parking brake, if the brake warning lamp (red) and the indicator on the Electric parking brake switch remain blinking or the Electric parking brake warning lamp (yellow) remains illuminated, the Electric parking brake system may be malfunctioning and the Electric parking brake may not be applied or released. Immediately park your vehicle in a safe place and contact the nearest MITSUBISHI MOTORS Authorized Service Point.
- If a vehicle is driven without releasing the Electric parking brake, the brake will overheat, resulting in ineffective braking and possible brake failure.
- If the brake warning lamp (red) does not go off after the parking brake has been released, the brake system may be malfunctioning. Contact the nearest MITSUBISHI MOTORS Authorized Service Point.

CAUTION

- If the acceleration of the vehicle seems abnormally slow after the vehicle has been parked with the Electric parking brake applied in cold weather, stop the vehicle in a safe place, then apply and release the Electric parking brake. If the vehicle acceleration is still slow, contact the nearest MITSUBISHI MOTORS Authorized Service Point.

NOTE

- When the operation mode of the power switch is other than ON, the parking brake cannot be released.
- If the Electric parking brake does not automatically release, it may be released by manual operation.
- When the select position is other than the “P” (PARK) position, if you try to release the Electric parking brake without depressing the brake pedal, the warning display will appear.



Parking

NOTE

- If you start driving without releasing the Electric parking brake, the warning display will appear.



- If the driver's foot contacts the accelerator pedal in the condition that the Electric parking brake can be released by an automatic operation, the Electric parking brake may be released automatically.

7

Warning display

Warning lamp (yellow)



Warning display



If there is a malfunction in the system, the warning lamp will come on. In addition, the warning display appears on the information screen in the multi information display. Under normal conditions, the warning lamp only comes on when the operation mode is put in ON and goes off a few seconds later.

CAUTION

- When the Electric parking brake warning lamp (yellow) does not illuminate or remains illuminated when the operation mode of the power switch is put in ON, or comes on while driving, the Electric parking brake may not be applied or released. Immediately contact the nearest MITSUBISHI MOTORS Authorized Service Point. For details, refer to "Electric parking brake warning lamp (yellow)" on page 6-56. When parking your vehicle while the Electric parking brake warning lamp (yellow) is illuminated, park the vehicle on level and stable ground, put the select position to "P" (PARK) and place chocks, blocks, or stones behind and in front of the tyres to prevent the vehicle from moving.

Parking

E00600602818

To park the vehicle, firmly apply the parking brake, and then press the electrical parking switch to lock the wheels.

Parking on a hill

To prevent the vehicle from rolling, follow these procedures:

Parking on a downhill slope

Turn the front wheels towards the kerb and move the vehicle forward until the kerb side wheel gently touches the kerb.

Apply the parking brake and press the electrical parking switch.

If necessary, apply chocks to wheels.

Parking on an uphill slope

Turn the front wheels away from the kerb and move the vehicle back until the kerb side wheel gently touches the kerb.

Apply the parking brake and press the electrical parking switch.

If necessary, apply chocks to wheels.

Parking with the engine running

Never leave the engine running while you take a short sleep/rest. Also, never leave the engine running in a closed or poorly ventilated place.

⚠ WARNING

- Leaving the engine running risks injury or death from accidentally moving the selector lever or the accumulation of toxic exhaust fumes on the passenger compartment.

Where you park

⚠ WARNING

- Do not park your vehicle in areas where combustible materials such as dry grass or leaves can come in contact with a hot exhaust, since a fire could occur.

When leaving the vehicle

Always carry the key and lock all doors and the tailgate when leaving the vehicle unattended.
Always try to park your vehicle in a well lit area.

⚠ CAUTION

- When you leave the vehicle, be sure that you have stopped the Plug-in Hybrid EV System. The engine may start suddenly by a remaining amount decline of the drive battery.

Steering wheel height and reach adjustment

E00600701652

1. Release the lever while holding the steering wheel up.
2. Adjust the steering wheel to the desired position.
3. Securely lock the steering wheel by pulling the lever fully upward.

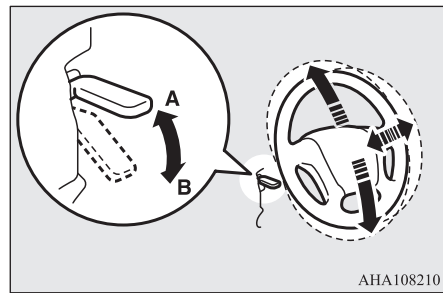

AHA108210

A- Locked
B- Release

⚠ WARNING

- Do not attempt to adjust the steering wheel while you are driving the vehicle.

Inside rear-view mirror

E00600802315

Adjust the rear-view mirror only after making any seat adjustments so you have a clear view to the rear of the vehicle.

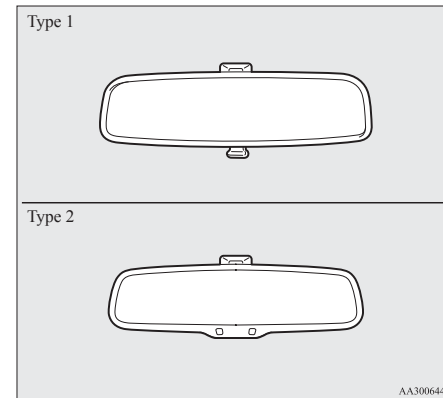

AA3006447

7

⚠ WARNING

- Do not attempt to adjust the rear-view mirror while driving. This can be dangerous. Always adjust the mirror before driving.

Adjust the rear-view mirror to maximize the view through the rear window.

Inside rear-view mirror

To adjust the vertical mirror position

It is possible to move the mirror up and down to adjust its position.

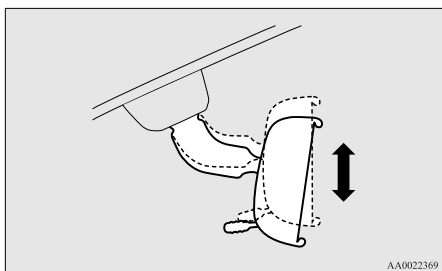

To adjust the mirror position

It is possible to move the mirror up/down and left/right to adjust its position.

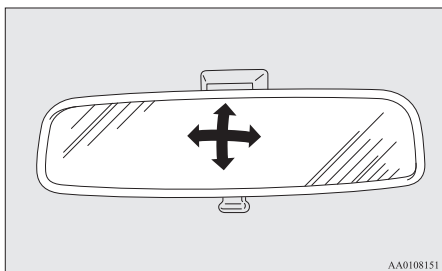

To reduce the glare

Type 1

The lever (A) at the bottom of the mirror can be used to adjust the mirror to reduce the glare from the headlamps of vehicles behind you during night driving.

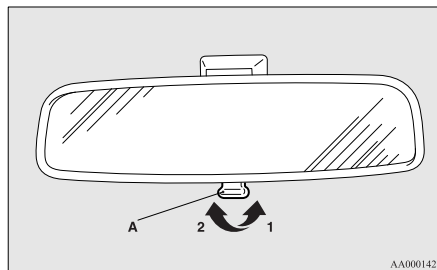

- 1- Normal
- 2- Anti-glare

Type 2

When the headlamps of the vehicles behind you are very bright, the reflection factor of the rear-view mirror is automatically changed to reduce the glare.

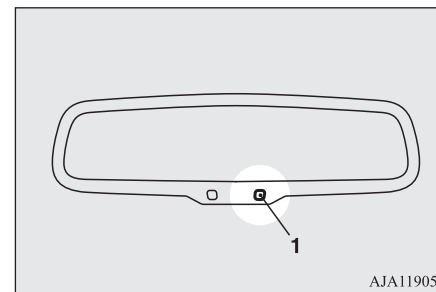

When the operation mode of the power switch is put in ON, the reflection factor of the mirror is automatically changed.

NOTE

- Do not hang items on, or spray glass cleaner on the sensor (1), as reduced sensitivity could result.

Outside rear-view mirrors

E0060900628

To adjust the mirror position

E00601001737

The outside rear-view mirrors can be operated when the operation mode is put in ON or ACC.

WARNING

- Do not attempt to adjust the rear-view mirrors while driving. This can be dangerous. Always adjust the mirrors before driving.
- Your vehicle is equipped with convex type mirrors. Please take into consideration, that objects you see in the mirror will look smaller and farther away compared to a normal flat mirror. Do not use this mirror to estimate distance of following vehicles when changing lanes.

1. Place the lever (A) to the same side as the mirror whose adjustment is desired.

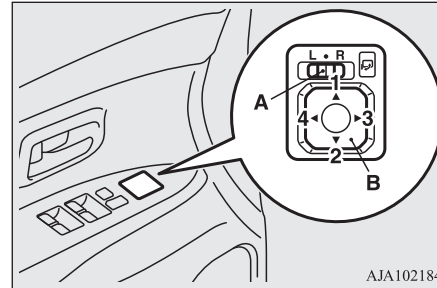

AJA102184

L- Left outside mirror adjustment
R- Right outside mirror adjustment

2. Press the switch (B) to the left, right, up or down to adjust the mirror position.
 - 1- Up
 - 2- Down
 - 3- Right
 - 4- Left
3. Return the lever (A) back to the middle position (•).

Retracting and extending the outside mirrors

E00601102272

The outside mirror can be folded in towards the side window to prevent damage when parking in narrow areas.

CAUTION

- Do not drive the vehicle with the mirror folded in. The lack of rearward visibility normally provided by the mirror could lead to an accident.

Retracting and extending the mirrors using the mirror retractor switch

With the operation mode in ON or ACC, push the mirror retractor switch to retract the mirrors. Push it again to extend the mirrors to their original positions.

After placing the operation mode in OFF, it is possible to retract and extend the mirrors using the mirror retractor switch for approximately 30 seconds.

7

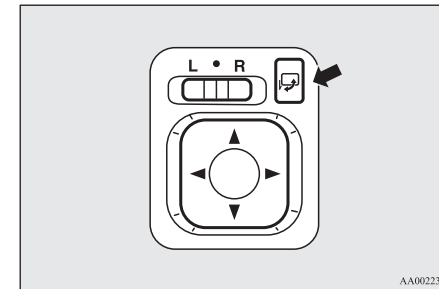

AA002298

Outside rear-view mirrors

⚠ CAUTION

- It is possible to retract and extend the mirrors by hand. After retracting a mirror using the mirror retractor switch, however, you should extend it by using the switch again, not by hand. If you extended the mirror by hand after retracting it using the switch, it would not properly lock in position. As a result, the mirror could move because of the wind or vibration while you are driving, and this may limit the driver's rearward visibility.

7

📖 NOTE

- Be careful not to get your hands trapped while a mirror is moving.
- If you move a mirror by hand or it moves after hitting a person or object, you may not be able to return it to its original position using the mirror retractor switch. If this happens, push the mirror retractor switch to place the mirror in its retracted position and then push the switch again to return the mirror to its original position.
- When freezing has occurred and mirrors fail to operate as intended, please refrain from repeated pushing of the retractor switch as this action can result in burn-out of the mirror motor circuits.

Retracting and extending the mirrors without using the mirror retractor switch

The mirrors automatically retract or extend when the doors and tailgate are locked or unlocked using the remote control switches or the keyless operation function of the keyless operation system.

Refer to “Keyless operation system: To operate using the key-less operation function, Keyless entry system” on pages 4-09 and 4-03.

📖 NOTE

- Functions can be modified as stated below. Please consult a MITSUBISHI MOTORS Authorized Service Point.
On vehicles equipped with the Smartphone Link Display Audio or the MITSUBISHI Multi-Communication System (MMCS), screen operations can be used to make the adjustment. Refer to the separate owner's manual for details.
 - Automatically extend when the operation mode is put in ON, and automatically retract when the driver's door is opened after the operation mode is put in OFF.
 - Automatically extend when the vehicle speed reaches 30 km/h (19 mph).
 - Deactivate the automatic extension function.

Heated mirror

E00601201755

To demist or defrost the outside rear-view mirrors, press the rear window demister switch.

The indication lamp (A) will illuminate while the demister is on.

The heater will be turned off automatically in approximately 15 to 20 minutes depending on the outside temperature.

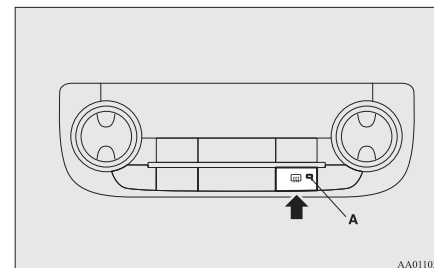

NOTE

- The heated mirror can be set so that it can turn on automatically only once if the ambient temperature becomes low, when the operation mode is put in ON.

For further information, we recommend you to consult a MITSUBISHI MOTORS Authorized Service Point. On vehicles equipped with the Smartphone Link Display Audio or the MITSUBISHI Multi-Communication System (MMCS), screen operations can be used to make the adjustment. Refer to the separate owner's manual for details.

Power switch

E00631801617

In order to prevent theft, the Plug-in Hybrid EV System will not start unless a preregistered keyless operation key is used. (Immobilizer function)

If you are carrying the keyless operation key, you can start the Plug-in Hybrid EV System.

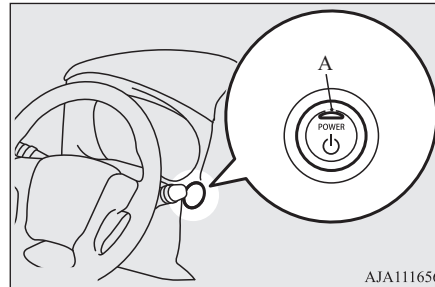

CAUTION

- The indication lamp (A) will flash orange when there is a problem or malfunction in the keyless operation system. Never drive if the indication lamp on the power switch is flashing orange. Immediately contact a MITSUBISHI MOTORS Authorized Service Point.
- If the power switch operation is not smooth and feels like it is sticking, do not operate the switch. Immediately contact a MITSUBISHI MOTORS Authorized Service Point.

NOTE

- When operating the power switch, press the switch all the way in. If the switch is not fully pressed, the Plug-in Hybrid EV System may not start or the operation mode may not change. If the power switch is pressed correctly, there is no need to hold the power switch down.
- When the battery in the keyless operation key has worn out, or the keyless operation key is out of the vehicle, a warning display will appear.

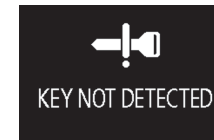

7

Operation mode of the power switch and its function

OFF

The indication lamp on the power switch turns off.

The operation mode cannot be put in OFF unless the electrical parking switch is pressed.

Power switch

ACC

Electrical devices such as the audio and accessory socket can be operated. Can be used when the Ready indicator is off.

The indication lamp on the power switch illuminates orange.

ON

All vehicle's electrical devices can be operated.

7

The indication lamp on the power switch illuminates blue. The indication lamp goes off when the Plug-in Hybrid EV System is operating.

NOTE

- Your vehicle is equipped with an electronic immobilizer. To start the Plug-in Hybrid EV System, the ID code which the transponder inside the key sends, must match the one registered in the immobilizer computer. Refer to "Electronic immobilizer (Anti-theft starting system)" on page 4-03.

Changing the operation mode

E00631901559

If you press the power switch without depressing the brake pedal, you can change the operation mode in the order of OFF, ACC, ON, OFF.

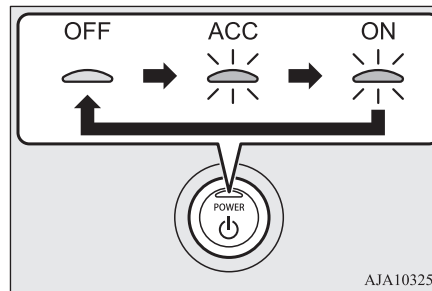

AJA103253

CAUTION

- When the Plug-in Hybrid EV System is not operating, put the operation mode in OFF. Leaving the operation mode in ON or ACC for a long time when the Plug-in Hybrid EV System is not operating may cause the auxiliary battery to discharge, making it impossible to start the Plug-in Hybrid EV System.

CAUTION

- When the auxiliary battery is disconnected, the current operation mode is memorized. After reconnecting the auxiliary battery, the memorized mode is selected automatically. Before disconnecting the auxiliary battery for repair or replacement, make sure to put the operation mode in OFF. Be careful if you are not sure which operation mode the vehicle is in when the auxiliary battery is run down.
- The operation mode cannot be changed from OFF to ACC or ON if the keyless operation key is not detected to be in the vehicle. Refer to "Keyless operation system: Operating range for starting the Plug-in Hybrid EV System and changing the operation mode" on page 4-08.

NOTE

- If the operation mode cannot be changed to OFF, perform the following procedure.
 - 1 Press the electrical parking switch and lock the wheels, then change the operation mode to OFF.
 - 2 One of the other causes could be low auxiliary battery voltage. If this occurs, the keyless entry system and keyless operation will also not operate. Contact a MITSUBISHI MOTORS Authorized Service Point.

ACC power auto-cutout function

E00632801265

After approximately 30 minutes have elapsed with the operation mode in ACC, the function automatically cuts out the power for the audio system and other electric devices that can be operated with that position.

When the power switch operates again, the power is supplied again.

NOTE

- It is possible to modify functions as follows:
 - The time until the power cuts out can be changed to approximately 60 minutes.
 - The ACC power auto-cutout function can be deactivated.

For details, we recommend you to consult a MITSUBISHI MOTORS Authorized Service Point.

On vehicles equipped with the Smartphone Link Display Audio or the MITSUBISHI Multi-Communication System (MMCS), screen operations can be used to make the adjustment.

Refer to the separate owner's manual for details.

Operation mode OFF reminder system

E00632201445



When the operation mode is in any mode other than OFF; if you try to lock the doors and tailgate by pressing the driver's or front passenger's door lock/unlock switch, or the tailgate LOCK switch, a warning display will appear, and the outer buzzer will sound preventing you from locking the doors and tailgate.

Operation mode ON reminder system

E00632301068



If the driver's door is opened while the Plug-in Hybrid EV System is stopped and the operation mode in any mode other than OFF, the operation mode ON reminder inner buzzer sounds intermittently to remind you to put the operation mode in OFF.

Starting and stopping the Plug-in Hybrid EV System

E00620601295

Starting the Plug-in Hybrid EV System

E00620701661

7

CAUTION

- When the Plug-in Hybrid EV System warning lamp comes on while the READY indicator is on, avoid high-speed driving and have your vehicle inspected by a MITSUBISHI MOTORS Authorized Service Point as soon as possible. (Refer to "Plug-in Hybrid EV System warning lamp" on page 6-57.)
- Never attempt to start the engine by pushing or pulling the vehicle.

1. Check that the EV charging cable is not connected to your vehicle.
2. Fasten the seat belt.
3. Make sure the parking brake is applied.
4. Press and hold the brake pedal down firmly with your right foot.

Starting and driving 7-13

Starting and stopping the Plug-in Hybrid EV System

- When you press the power switch while depressing the brake pedal, the READY indicator in the meter blinks and the activation of Plug-in Hybrid EV System starts.
- When the READY indicator changes from blinking to staying on, the startup of Plug-in Hybrid EV System is activated and the vehicle is now ready to drive.

7

CAUTION

- Do not press the power switch while holding the select lever at the operated position.

NOTE

- Continue to depress the brake pedal until the READY indicator in the meter stays on.
- After the Plug-in Hybrid EV System has not started for a while, the brake pedal effort needed to start the Plug-in Hybrid EV System may become greater.
If this occurs, depress the brake pedal more than usual.
- You can drive your vehicle even if the engine is stopped.
- The Plug-in Hybrid EV System can be started in any operation mode.
- If the READY indicator does not come on, check the select position indicator. If the indicator does not indicate "P", press the electrical parking switch to display "P" position.

NOTE

- If the READY indicator does not come on, turn the power switch to OFF once and, after a while, press the power switch to start Plug-in Hybrid EV System.

Stopping the Plug-in Hybrid EV System

E00620801457

- Stop your vehicle completely.
- Apply the parking brake firmly while depressing the brake pedal.
- After pressing the electrical parking switch, press the power switch to stop the Plug-in Hybrid EV System. (Refer to "Electrical Parking switch" on page 7-18.)

WARNING

- Never stop the Plug-in Hybrid EV System during running except in an emergency. The effectiveness of the brake becomes very poor and the steering wheel becomes very heavy, which can easily lead to an accident.**

NOTE

- Do not operate the power switch during running except in an emergency. If you have to stop the Plug-in Hybrid EV System because of an emergency during operation, continue to press the power switch for three seconds or longer or press the power switch three times or more quickly. The Plug-in Hybrid EV System stops, the operation mode turns to ACC, and the selector lever position shifts to the "P" position at very slow speed.
- If you press the power switch when the selector lever position is other than the "P" position while your vehicle is stopped, the selector lever position automatically shifts to the "P" position, Plug-in Hybrid EV System stops, and the power mode turns to "OFF".
- If the parking lock mechanism is faulty, a warning is displayed on the information screen in the multi-information display. When this warning is displayed, the Plug-in Hybrid EV System cannot be stopped unless you apply the parking brake and then press the power switch. Park on a flat place with the parking brake securely applied. Have your vehicle inspected by a MITSUBISHI MOTORS Authorized Service Point.



P LOCK MALFUNCTION
WHEN PARKING, APPLY
PARKING BRAKE SECURELY

If the keyless operation key is not operating properly

E00632901237

Insert the keyless operation key into the key slot. Starting the Plug-in Hybrid EV System and changing the operation mode should be now possible.

Remove the keyless operation key from the key slot after starting the Plug-in Hybrid EV System or changing the operation mode.

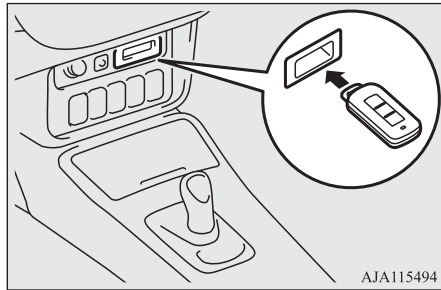

NOTE

- Do not insert into the key slot anything other than the keyless operation key. This could cause damage or a malfunction.

NOTE

- Remove the object or additional key from the the keyless operation key before inserting the key into the key slot. The vehicle may not be able to receive the registered ID code from the registered key. Therefore, the Plug-in Hybrid EV System may not start and the operation mode may not change.
- The keyless operation key is fixed in the key slot when inserted in the illustrated direction. Simply pull out the key to remove it from the key slot.

Keyless operation key reminder

E00633001046



If the operation mode is in OFF and the driver's door is opened with the keyless operation key in the key slot, the outer buzzer sounds for approximately 3 seconds and the inner buzzer sounds for approximately 1 minute or a warning display will appear to remind you to remove the key.

OGGE19E1

Selector lever (Joystick type)

Selector lever (Joystick type)

E00636100100

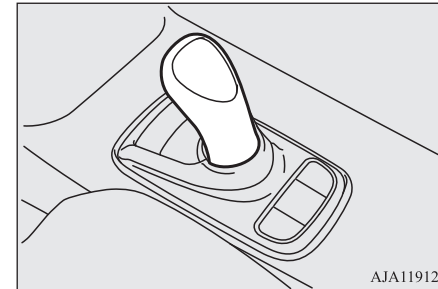

7

Selector lever operation

E00636200097

The selector lever always returns to its home (●) position when it is released.

Selector lever (Joystick type)

The position you select with the selector lever will be illuminated on the shift position panel shown in the illustration below.

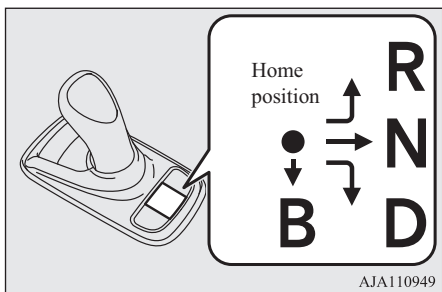

Move the selector lever slowly and securely in the following method.

- To select “D” (DRIVE) or “R” (REVERSE):
Move the selector lever in the direction of the arrow.
- To select “N” (NEUTRAL):
Move the selector lever in the direction of the arrow and hold it for a while.
- To select “B” (REGENERATIVE BRAKE):
Move the selector lever in the direction of the arrow.

The “B” (REGENERATIVE BRAKE) position can only be selected while the select position is in the “D” (DRIVE) position. When the selector lever is moved to the “B” position, the regenerative brake force will become stronger.

When the selector lever is again moved to the “B” position, the maximum regenerative brake force will be used.

To return to the “D” position, use the selector lever to select the “D” position.

NOTE

- If you operate the selector lever to “B” twice too quickly, the regenerative brake force may not become the maximum.

WARNING

- Do not replace the selector lever knob with anything other than a MITSUBISHI MOTORS genuine part. In addition, do not hang an object on the selector lever as it may be the cause of an accident.
- When you shift the selector lever to “D” or “R” position, always depress the brake pedal with your right foot for your safety. Never shift the lever while depressing the accelerator pedal. Doing so will start your vehicle abruptly, which may lead to a serious accident. It may also be a cause of failure of the vehicle.

NOTE

- You cannot operate the regenerative brake while the adaptive cruise control system (ACC) is operating.
- Every time while operating the selector lever, be sure to check the position displayed on the indicator.
- If you perform the following operation, the buzzer may sound and the select position may automatically shift to the “N” (NEUTRAL) position.
 - If the electrical parking switch is pressed while the vehicle is in motion.
 - If the selector lever is moved to the “R” (REVERSE) position while the vehicle is moving forward.
 - If the selector lever is moved to the “D” (DRIVE) position while the vehicle is moving backward.
 - If the selector lever is moved to the “B” (REGENERATIVE BRAKE) position after it had been shifted to the “R” (REVERSE) position.
- If you perform the following operation, the buzzer sounds and the selector lever operation is cancelled.
 - When in the “P” (PARK) position, the selector lever is moved without depressing the brake pedal.
 - When in the “P” (PARK) or “N” (NEUTRAL) position, the selector lever is moved to “B” (REGENERATIVE BRAKE).

Select position indicator

NOTE

- When the operation mode is in the “ON” position with the Plug-in Hybrid EV System not operated, the selector lever is shifted to the “D” (DRIVE) or “R” (REVERSE) position.
- If you shift and hold the selector lever for approximately 10 seconds or longer, the buzzer sounds. The buzzer stops sounding when you release the selector lever.
- If the driver’s door is opened while the vehicle is stopped or is running at very low speed with the select position in other than the “P” (PARK) position and the READY indicator in the meter is illuminating, the buzzer sounds. The buzzer stops sounding if you close the door or shift the selector lever to “P” (PARK).

Select position indicator

E00636300102

This indicator displays the selector lever position in the meter.

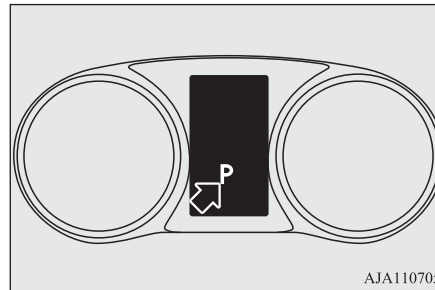

AJA110705

NOTE

- When the “B” position is selected, the selected regenerative brake force position is also displayed at “B” position.
- You cannot operate the regenerative brake while the adaptive cruise control system (ACC) is operating.

Selector lever positions

E00636400099

“P” PARK

The wheels are locked. When you park your vehicle, be sure to apply the parking brake and press the electrical parking switch.

OGGE19E1

“R” REVERSE

This position is to back up.

“N” NEUTRAL

No power is transmitted to the wheels. The wheels are not locked.

WARNING

- Never move the selector lever to the “N” (NEUTRAL) position while driving, you will lose regenerative braking.
- Always keep your right foot on the brake pedal when shifting into or out of “N”, to minimize the risk of loss of control.

7

“D” DRIVE

This position is for normal driving.

“B” REGENERATIVE BRAKE

This position is for the regenerative braking. You can adjust the regenerative braking force up to two levels.

Refer to “Selector lever operation” on page 7-15.

Refer to “Braking: When driving downhill” on page 7-34.

Starting and driving 7-17

Electrical Parking switch

WARNING

- Sudden regenerative brake may cause the tyres to skid. Select this position according to the road conditions and vehicle speed.

CAUTION

- When the capacity of the drive battery is close to full or when the drive battery temperature is low, the regenerative brake will become less effective. In such case, depress the brake pedal strongly.

NOTE

- If a large regenerative braking force is generated by using the selector lever or the regenerative braking level selector, the stop lamps will be automatically illuminated.

Electrical Parking switch

E00636600062

When you park your vehicle, be sure to apply the parking brake and press the electrical parking switch to lock the wheels. The indicator on the switch illuminates in green and the select position indicator displays “P” on the information screen in the meter.

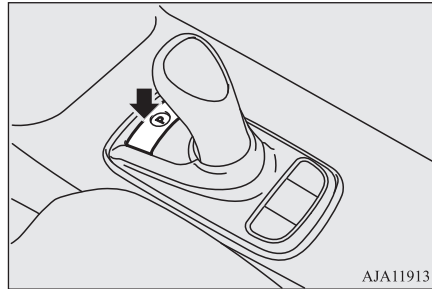

AJA119131

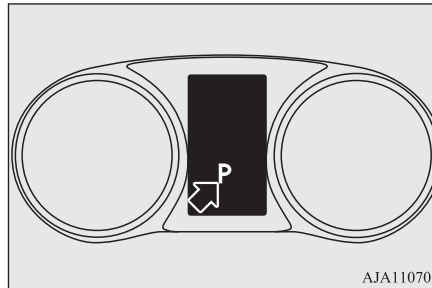

AJA110705

CAUTION

- If you operate the electrical parking switch and the select lever repeatedly within a short time, the shifting from the “P” position or to the “P” position is restrained for a certain period for the system protection. In such a case, wait for a while and then perform the operation.
- If the parking lock mechanism is faulty, a warning is displayed on the information screen in the multi-information display. When this warning is displayed, park on a flat place with the parking brake securely applied. Have your vehicle inspected by a MITSUBISHI MOTORS Authorized Service Point.



- If you press the electrical parking switch before your vehicle stops completely, the vehicle makes a sudden stop, which may cause injury to passengers. This also can be a cause of failure of the vehicle.
- Do not place an object around the electrical parking switch. The electrical parking switch may be pressed by the object when you place it there or when you somehow touch it. This will cause unintentional shifting to “P” or “N” position, which may lead to an accident.

Regenerative braking level selector (paddle type)*

⚠ CAUTION

- Be careful not to spill beverages, etc. around the electrical parking switch. The electrical parking switch may be stuck to the pressed position when it is pressed.

📖 NOTE

- When the selector lever is shifted from the “P” position or to the “P” position, operating noise and vibration of the parking lock are felt, but this is normal.

Electrical Parking switch reminder buzzer

If the driver's door is opened with the select position other than “P” when the vehicle is at a stop, the buzzer sounds to warn to press the electrical parking switch.

Regenerative braking level selector (paddle type)*

E00636700148

Regenerative braking level selector can quickly change the regenerative brake force keeping your hand on the steering wheel when you release your foot from the accelerator pedal while driving.

By pulling the regenerative braking level selector, the brake force (amount of electrical energy to charge the drive battery) can be adjusted according to the driving condition such as before a curve or a downhill.

Regenerative braking level can be switched in the 6 level from B0 (without regenerative brake force) to B5 (large regenerative brake force).

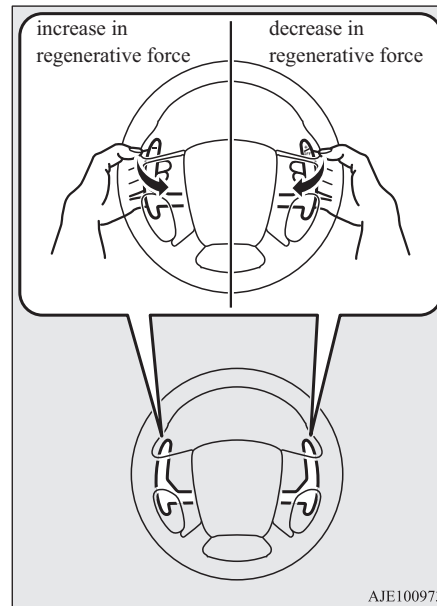

⚠ CAUTION

- If a large regenerative brake force is applied on a slippery road, tyres may skid. Always drive safely in accordance with the prevailing road condition.
- If you operate the right and left paddles simultaneously, the regenerative brake force level may not change.

📖 NOTE

- Repeated continuous operation of a paddle will continuously change the brake force levels.
- If you turn on the SPORT mode, the regenerative braking force level will automatically switch to B5. After the regenerative braking force level is switched, the regenerative braking level can be adjusted by the regenerative braking level selector.
- If you turn on the cruise control when the level B0 or B1 (smaller regenerative brake force) is selected, the level is returned to the normal level B2 automatically.
- When stronger regenerative braking is generated, the stop lamps will illuminate even when the brake pedal is not depressed.
- Under the cruise control, the level B0 or B1 cannot be selected. The buzzer sounds if you try to select these levels.

7

S-AWC (Super All Wheel Control)

NOTE

- On vehicles with the adaptive cruise control system (ACC), you cannot control the regenerative brake force level while the adaptive cruise control system (ACC) is operating. The buzzer sounds if you operate the paddles.

To decrease regenerative brake force

7

Each time you pull the “+” paddle towards you, the regenerative brake force lowers by one level.

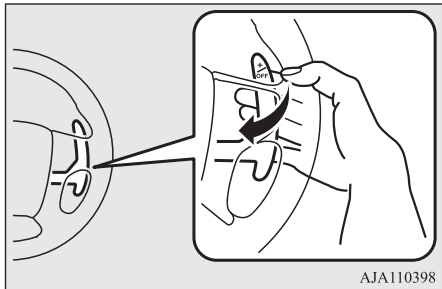

To increase regenerative brake force

Each time you pull the “-” paddle towards you, the regenerative brake force rises by one level.

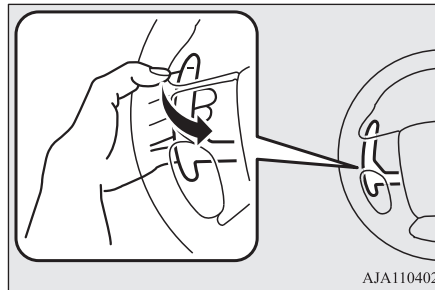

To return to the normal regenerative brake force level of B2

Pull the “+” paddle for approximately 2 seconds or longer. The select lever position indicator displays “D”.

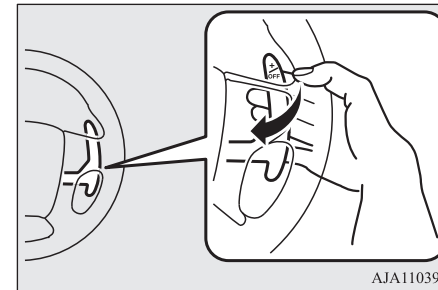

S-AWC (Super All Wheel Control)

E00622601185

S-AWC is an integrated vehicle dynamics control system that helps enhance driving performance, cornering performance, and vehicle stability over a wide range of driving conditions through integrated management of the twin motor 4WD, the AYC (Active Yaw Control), the ABS and the ASC.

S-AWC (Super All Wheel Control)

⚠ CAUTION

- Do not over-rely on the S-AWC. Even the S-AWC cannot prevent the natural laws of physics from acting on the vehicle. This system, like any other system, has limits and cannot help you to maintain traction and control of the vehicle in all circumstances. Reckless driving may lead to accidents. It is the driver's responsibility to drive carefully. This means taking into account the traffic, road and environmental conditions.

Twin Motor 4WD

This system improves vehicle stability performance and fuel economy performance during acceleration and deceleration by motors provided at front and rear wheels, respectively, controlling the distribution of a drive force between the front and rear wheels optimal for the operation of the driver.

Active yaw control system (AYC)

The AYC is a system, with a left-right differential limiting function and yaw control function, that controls the left-right driving/braking force by managing the brake.

E00622801044

⚠ CAUTION

- Control of the braking force does not enhance the stopping performance of the vehicle, therefore, pay careful attention to the safety of your surroundings when driving.

Left-right differential limiting function

The left-right differential limiting function is a function that enhances driving performance and vehicle stability by preventing idle spinning of a wheel when driving on a slippery road or when the road surfaces of left and right wheels are different.

Yaw control function

The yaw control function is a function that enhances vehicle cornering performance and vehicle stability with management of vehicle turning power (yaw moment) by controlling the brake force when the vehicle does not turn in response to steering input, such as when the steering wheel is turned quickly or when driving on a slippery road.

S-AWC drive mode

Select the drive mode from the following three types to suit the driving conditions.

E00653100020

S-AWC drive mode	Function
NORMAL	This mode can be used on both dry and wet roads. The distribution of driving/braking torque to each wheel is automatically controlled according to the driving condition.
SNOW	This mode is for driving on slippery road surfaces, such as snow-covered roads and improves stability on a slippery road.
LOCK	This mode is for driving where maximum traction is required. This mode is suitable for driving on rough roads or driving in sand or fresh snow.

Drive mode switch

When the operation mode of the power switch is in ON, operate the drive mode switch (A) to change the S-AWC drive mode.

E00653200021

7

S-AWC (Super All Wheel Control)

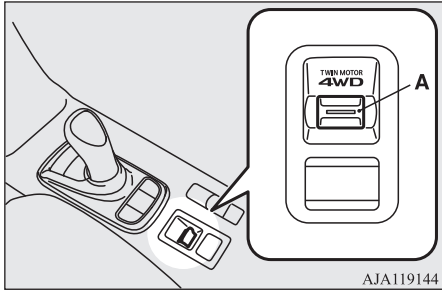

7

⚠ CAUTION

- Use tyres of the same specified size, same type, same brand and with no wear difference. If tyres of a different size, type, brand or degree of wear are used, a warning of EV system abnormality may be displayed.

📖 NOTE

- Even if the S-AWC drive mode is selected, after turning the operation mode of the power switch OFF and turning to ON again, the S-AWC drive mode is set to "NORMAL".
- The drive mode can be switched while driving or stopped.

S-AWC drive mode display

E00653300022



Example: "SNOW" mode is selected.

The currently selected drive mode is displayed on the multi-information display. In addition, when the drive mode is changed, the selected mode appears on the interrupt display screen of the information screen in the multi-information display. The drive mode display will appear on the information screen for a few seconds, and then the original screen will return.

S-AWC operation display

E00623101347

The S-AWC operation status can be displayed on the information screen in the multi-information display.

To display the status, press the multi-information display switch to change the information screen.

Refer to "Information screen (when the operation mode is ON)" on page 6-09.

Display example

The S-AWC operation status is displayed.

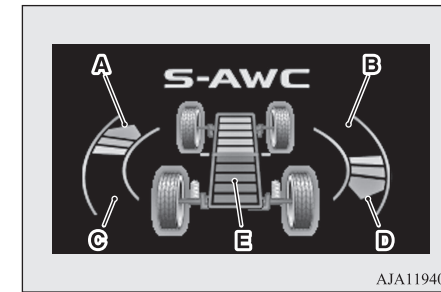

Yaw control function display

The amount of the yaw moment is displayed as a bar graph.

- A,D- Clockwise yaw moment about the vehicle's center of gravity
- B,C- Anticlockwise yaw moment about the vehicle's center of gravity

Torque distribution function display

The torque distribution between the front and rear wheels is displayed in section E of the meter as a bar graph.

If the red line is on the front, the torque of the front motor will be high. If it is behind it, the torque of the rear motor will be high.

⚠ WARNING

- **Always concentrate on your driving first. Keep your eyes and mind on the road. Distractions while driving can lead to an accident.**

4-wheel drive operation

E00606602605

Your vehicle has been designed primarily for use on paved roads.

But its unique 4-wheel drive system allows you to occasionally travel on unpaved roads, to campgrounds, picnic sites, and similar locations.

Not only does this ensure better handling on dry, paved roads but also permits better traction when driving on slippery, wet or snow-covered roads and when moving out of mud.

But it is not suitable for heavy off road use or towing in rough conditions.

It is particularly important to note that 4-wheel drive may not give sufficient hill climbing ability with the regenerative brake on steep slopes. You should try to avoid driving on steep slopes.

Also, you must exercise caution when driving on sand and mud and when driving through water because sufficient traction may not be available in certain circumstances.

Please avoid driving the vehicle through areas where the tyres may get stuck in deep sand or mud.

⚠ WARNING

- **Do not over-rely on the 4-wheel drive vehicles. Even 4-wheel drive vehicles have limits to the system and ability to maintain control and traction. Reckless driving may lead to accidents. Always drive carefully, taking account of the road conditions.**
- **Improperly operating this vehicle on or off-paved roads can cause an accident or rollover in which you and your passengers could be seriously injured or killed.**
 - **Follow all instructions and guidelines in the owner's manual.**
 - **Keep your speed low and do not drive faster than conditions allow you to.**

📖 NOTE

- Driving on rough roads can be hard on a vehicle. Before you leave paved roads, be sure all scheduled maintenance and service has been done, and that you have inspected your vehicle. Pay special attention to the condition of the tyres, and check the tyre pressures.

📖 NOTE

- MITSUBISHI MOTORS is not responsible for any damage or injury caused or liability incurred by improper and negligent operation of a vehicle by the operator. All techniques of vehicle operation depend on the skill and experience of the operator and other participating parties. Any deviation from the recommended operating instructions above is at their own risk.
- Note that the stopping distance required of a 4-wheel drive vehicle differs very little from that of a 2-wheel drive vehicle. When driving on a snow-covered road or a slippery, muddy surface, make sure that you keep a sufficient distance between your vehicle and the one ahead of you.
- The driving posture should be more upright; adjust the seat to a good position for easy steering and pedal operation. Be sure to wear the seat belt.
- After driving on rough roads, check each part of the vehicle and wash it thoroughly with water. Refer to the "Inspection and maintenance following rough road operation" section and "Maintenance" section.

Inspection and maintenance following rough road operation

NOTE

- When moving out of mud, sand or fresh snow, pressing the accelerator pedal may not allow the Plug-in Hybrid EV system output to increase. In such situations, switching to “LOCK” with the S-AWC drive mode switch and temporarily turning off the Active Stability Control (ASC) with the “ASC OFF” switch will make it easier to move out your vehicle. Refer to “Operation under adverse driving conditions: If your vehicle becomes stuck in sand, mud or snow” on page 9-21.

7

On snowy or icy roads

Set the drive mode to “SNOW” in accordance with the road conditions, and then gradually depress the accelerator pedal for a smooth start.

CAUTION

- Avoid sudden braking, sudden acceleration and sharp turning. Skidding occurs and control of the vehicle could be lost.

NOTE

- The use of snow tyres and/or snow traction device (tyre chains) is recommended.
- Maintain a safe distance between vehicles, avoid sudden braking, and use regenerative braking.

Driving on sandy or rough roads

Set the drive mode to “LOCK” and then gradually depress the accelerator pedal for a smooth start. Keep the pressure on the accelerator pedal as constant as possible, and drive at low speed.

Climbing/descending sharp grades

Your vehicle may not provide sufficient hill climbing ability and regenerative brake on steep slope. Avoid driving on steep slopes even though the vehicle is a 4-wheel drive vehicle.

Inspection and maintenance following rough road operation

E00606701407

After operating the vehicle in rough road conditions, be sure to perform the following inspection and maintenance procedures:

- Check that the vehicle has not been damaged by rocks, gravel, etc.
- Carefully wash the vehicle with water. Drive the vehicle slowly while lightly depressing the brake pedal in order to dry out the brakes. If the brakes still do not function properly, we recommend you to have the brakes checked as soon as possible.
- Remove the insects, dried grass, etc. clogging the radiator core.
- Check the inside of the vehicle. If water entry is found, dry the carpet etc.

- Inspect the headlamps. If the headlamp bulb is flooded with water, we recommend you to have it drained.

Cautions on handling of 4-wheel drive vehicles

E00606801844

Tyres and wheels

Since the driving torque can be applied to the 4 wheels, the driving performance of the vehicle when operating in 4-wheel drive is greatly affected by the condition of the tyres.

Pay close attention to the tyres.

- Install only the specified tyres on all wheels. Refer to “Tyres and wheels” on page 12-09.
- Be sure all 4 tyres and wheels are the same size and type.
When it is necessary to replace any of the tyres or wheels, replace all 4 tyres.
- All tyres should be rotated before the wear difference between the front and rear tyres is recognizable.

Good vehicle performance cannot be expected if there is a difference in wear between tyres. Refer to “Tyre rotation” on page 11-12.

- Check the tyre inflation pressure regularly.

CAUTION

- Always use tyres of the same size, same type, and same brand, and which have no wear differences. Using tyres of different size, type, brands or degree of wear, will increase the differential oil temperature, resulting in possible damage to the driving system. Further, the drive train will be subjected to excessive loading possibly leading to oil leakage, component seizure, or other serious faults.

Towing

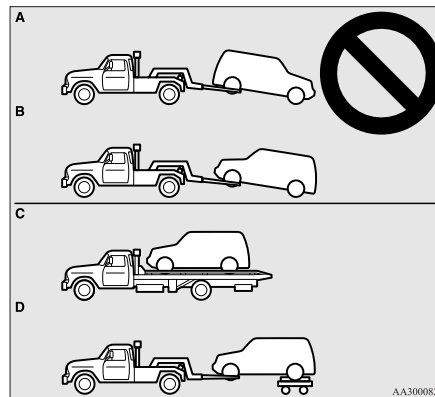

CAUTION

- Do not tow 4-wheel drive vehicles with the front or rear wheels on the ground (Type A or Type B) as illustrated. This could result in damage to the drivetrain, or unstable towing. If you tow 4-wheel drive vehicles, use Type C or Type D equipment.

Jacking up a 4-wheel drive vehicle

WARNING

- Do not turn on the Plug-in Hybrid EV System or turn a jacked-up wheel when the vehicle is jacked up. The tyre in contact with the ground may turn and the vehicle may come off the jack, possibly leading to an accident. Besides, do not touch the high-voltage area.

EV switch

E00653000087

To drive the vehicle without starting the engine as much as possible, the EV priority mode can be used.

This mode helps to drive the vehicle at a place needed for concern of noises and exhaust gas emissions, such as residential areas etc.

EV switch

To switch to the EV priority mode, press the EV switch with operation mode of the power switch in ON.

If the EV switch is pressed, you can drive the vehicle by using only the EV drive mode as much as possible, even if the accelerator pedal is roughly depressed.

To cancel the EV priority mode, press the EV switch again.

When the operation mode of the power switch is put in OFF, the EV priority mode will be cancelled.

7

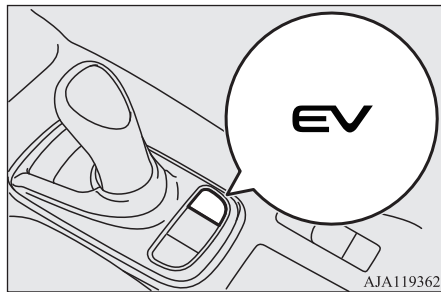

When switching to the EV priority mode, on the information screen in the multi information display, a screen showing the EV priority mode is displayed. The EV priority mode indication on the upper left of the screen also indicates the engine operating state. When the engine is not running, it is displayed in blue, and when the engine is running, it is displayed in gray.

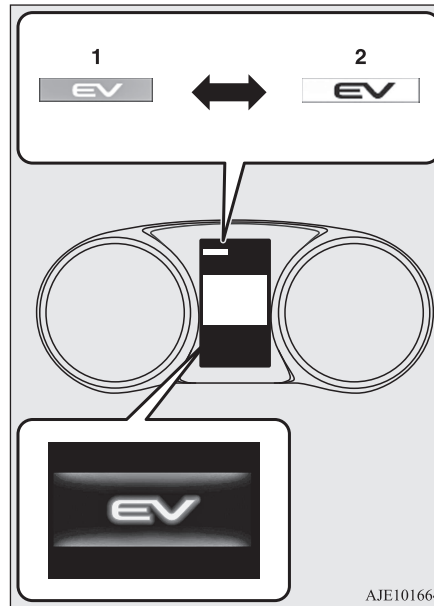

1: Engine is not running (blue)

2: Engine is running (gray)

NOTE

- While driving the vehicle in the EV priority mode, if the engine automatically starts while the vehicle is accelerating, the vehicle may accelerate more quickly.
- In the following conditions, the EV priority mode cannot be used even if the EV switch is pressed, a buzzer will sound and the message will appear in the multi information display.

- When the remaining power in the drive battery is low.
Charge the drive battery.



- When the cruise control or the adaptive cruise control system (ACC) is operating.



If you want to use the EV priority mode, cancel the cruise control or the ACC.

NOTE

- When the drive battery temperature is too cold.



- When using the EV priority mode is limited to protect the Plug-in Hybrid EV System.



- While the following message is displayed in the multi information display, the EV priority mode cannot be used even if the EV switch is pressed, a buzzer will sound.



NOTE

- If you select warm air with the air conditioner switch during driving in the EV priority mode, the message will appear in the multi information display. (except for vehicles with electric heater)



- In any of the situations listed below, the EV priority mode will be automatically canceled and the message will appear in the multi information display.
 - When the remaining power in the drive battery becomes low. Charge the drive battery.



NOTE

- When the vehicle speed of the cruise control or the ACC is set.



If you want to use the EV priority mode, cancel the cruise control or the ACC.

- When the drive battery temperature becomes too cold.



- When the protecting device of the Plug-in Hybrid EV System is operated.



7

SAVE/CHARGE mode switch

NOTE

- If the EV switch is pressed during the heating of the air conditioner, the message will appear in the multi information display. (except for vehicles with electric heater)



- When the SAVE/CHARGE mode switch or the SPORT mode switch is pressed while driving in the EV priority mode, the mode changes to the selected mode. If the EV switch is pressed, the mode is returned to the EV priority mode. However, the mode may not return to the EV priority mode depending on the remaining power in the drive battery.
- In any of the situations listed below, the EV priority mode continues even if the engine is automatically started.
 - When the accelerator pedal is fully depressed.
 - When the vehicle speed is over 130 km/h (80 mph).
 - When the demister switch is pressed.

NOTE

- If the ambient temperature is low, the engine may start for heating when the Plug-in Hybrid EV system is started with air conditioner performed. If you want to stop the engine running, select the EV priority mode with the operation mode of the power switch in ON before starting the Plug-in Hybrid EV system.
- In the EV priority mode, the accelerator pedal response may be negative even if the accelerator pedal is depressed or released.
- The motor output in the EV priority mode may decrease due to the deteriorated drive battery or the ambient temperature falls. In such a case, start the engine by cancelling the EV priority mode to secure the motor output.

SAVE/CHARGE mode switch

E00653600025

If you press the switch with the operation mode of the power switch in ON, you can change the drive battery mode in the order of SAVE, CHARGE, OFF, SAVE.

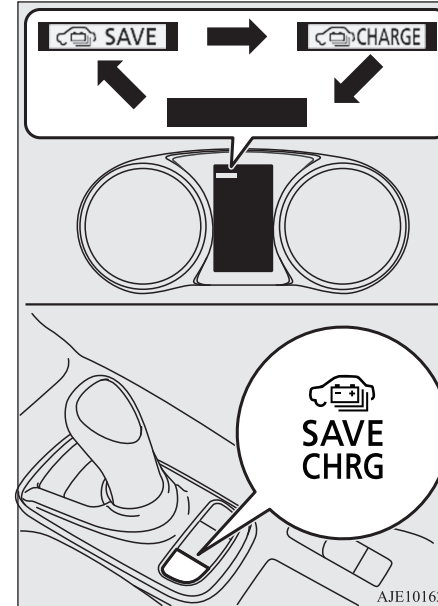

Battery save mode

E00653700026

To save the remaining power in the drive battery while driving, the battery save mode can be used. This mode helps preserve the electrical power in the drive battery for later use, such as in a residential area, or to use at your destination. The battery save mode can also be used to reduce electric power consumption from the drive battery during high-speed driving.

When the battery save mode is activated, the engine will start in order to preserve the remaining power of the drive battery and the vehicle will operate in the series hybrid mode or the parallel hybrid mode depending on the remaining power in the drive battery.

To cancel the battery save mode, press the SAVE/CHARGE mode switch twice.

When the operation mode of the power switch is put in OFF, the battery save mode will be cancelled.

If the battery save mode is activated, the following image is displayed on the information screen in the multi-information display.

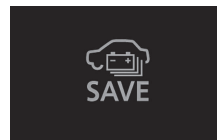

NOTE

- The engine may stop when the vehicle stops or is running.
- Even if the battery save mode is selected, the engine may not start depending on the condition of the remaining drive battery capacity or the Plug-in Hybrid EV system control.
- In the following conditions, the battery save mode cannot be used even if the battery save mode is selected, a buzzer will sound and the message will appear in the multi-information display.
 - When the engine coolant temperature is high.
 - When the remaining fuel quantity is low.

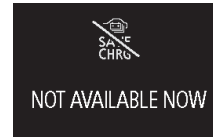

- In any of the situations listed below, the battery save mode will be automatically cancelled and the message will appear in the multi-information display.
 - When the engine coolant temperature becomes high.

NOTE

- When the remaining fuel quantity becomes low.



- When one of the following switches is pressed while driving in the battery save mode, the mode changes to the selected mode.
 - SAVE/CHARGE mode switch
 - EV switch
 - SPORT mode switch

Refer to “Battery charge mode” on page 7-29, “EV switch” on page 7-25 or “SPORT mode switch” on page 7-31.

If the SAVE/CHARGE mode switch is pressed once, the mode is returned to the battery save mode.

7

Battery charge mode

E00653800027

To charge the drive battery while driving, the battery charge mode can be used. It is recommended to use this mode before driving up long hills or mountain roads.

When the battery charge mode is activated, the engine will start to charge the drive battery to nearly full.

To cancel the battery charge mode, press the SAVE/CHARGE mode switch once.

Starting and driving 7-29

SAVE/CHARGE mode switch

When the operation mode of the power switch is put in OFF, the battery charge mode will be cancelled.

If the battery charge mode is activated, the following image is displayed on the information screen in the multi-information display.



7

WARNING

- When you leave the vehicle, be sure to stopped the Plug-in Hybrid EV System. Refer to “Parking” on page 7-06
- Only use the battery charge mode in a well ventilated space.
The engine will start when the vehicle is in the battery charge mode, and this can cause carbon monoxide to build up causing carbon monoxide poisoning. Be sure to use at the well-ventilated place.
- Do not use the battery charge mode near flammable objects such as dried grass or paper etc. There is a possibility of starting a fire due to the high exhaust pipe temperature.

CAUTION

- While the battery charge mode is activated, do not cover the front of the vehicle with anything including a car cover. Doing so could cause the engine to overheat.

NOTE

- Even if the battery charge mode is selected, the engine may not start depending on the condition of the remaining drive battery capacity or the Plug-in Hybrid EV system control.
- In the following conditions, the battery charge mode cannot be used even if the battery charge mode is selected, a buzzer will sound and the message will appear in the multi-information display.
 - When the engine coolant temperature is high.
 - When the remaining fuel quantity is low.

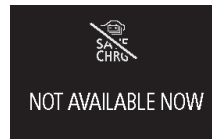

- In any of the situations listed below, the battery charge mode will be automatically cancelled and the message will appear in the multi-information display.
 - When the engine coolant temperature becomes high.

NOTE

- When the remaining fuel quantity becomes low.



- It is recommended to use the battery charge mode at least 20 minutes before you climb, in order to continue a speed of more than 100 km/h (62 mph), or when a long slope (gradient of more than 4 %) is expected. (According to a towing weight, it may not be able to continue the speed.)
- When using the battery charge mode with a vehicle that has stopped in the heat a long time, it may not charge.
- The charging time close to full charge of the drive battery becomes longer depending on the condition of the drive battery, a driving condition or a environment.
- The engine may stop near full charge.
- If you use the battery charge mode, in order to generate electricity using gasoline, the fuel consumption will suffer. We recommend you to consider the environment.

NOTE

- When the engine is started while parking, there is a risk of receiving a penalty due to idling stop ordinances.
You should use the battery charge mode that conforms to the relevant municipality.
Also, if the engine is started, ensure there is sufficient fuel in the fuel tank so that the engine does not run out of fuel.
- When the EV switch or the SPORT mode switch is pressed while driving in the battery charge mode, the mode changes to the selected mode.
Refer to “EV switch” on page 7-25 or “SPORT mode switch” on page 7-31.
If the SAVE/CHARGE mode switch is pressed twice, the mode is returned to the battery charge mode.

SPORT mode switch

E00653900028

The SPORT mode switch is used when doing powerful sporty driving on mountain roads and uphill slopes.

Quick acceleration in response to the operation of the accelerator pedal and quick deceleration by strong regenerative braking force are possible.

The SPORT mode can be used when the SPORT mode switch is pressed while the READY indicator light is on.

To cancel, press the switch again or turn off the power mode.

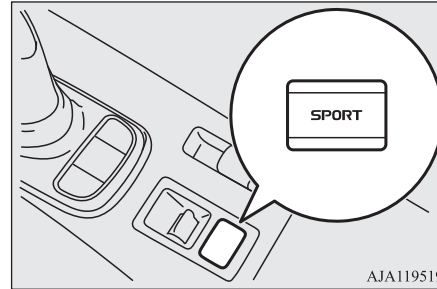

AJA119519

If the SPORT mode is activated, the following display appears on the information screen in the multi-information display.

**WARNING**

- **If a large regenerative braking force is applied, the stop lamps will be automatically illuminated.**

NOTE

- Selecting the SPORT mode makes the engine easier to start. Also, since the response to the operation of the accelerator pedal becomes better, there may be a shock when stepping on the accelerator pedal.
- When SPORT mode is selected, the regenerative braking force automatically switches to B5. After switching, you can change to your favorite regenerative braking force with the Regenerative braking level selector. Regenerative braking level selector (paddle type) → p. 7-19
- When you select the SPORT mode in situations such as the following, a large regenerative braking force may not work.
 - When the driving battery temperature is high or low.
 - When the driving battery is close to fully charged, or when it is fully charged.
- If you select the cruise control or the Adaptive Cruise Control System (ACC), the regenerative braking level will be D while driving in the SPORT mode.
The regenerative brake force becomes B5 when the SPORT mode is returned by cancelling the cruise control or the Adaptive Cruise Control System (ACC).

Acoustic Vehicle Alerting System (AVAS)

NOTE

- When the remaining amount of fuel is small, the SPORT mode cannot be used even if the SPORT mode switch is pressed.

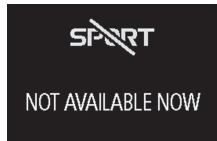

If you want to use the SPORT mode, refuel the vehicle.

- While the following message is displayed in the multi-information display, the SPORT mode cannot be used even if the SPORT mode switch is pressed and a buzzer will sound.



NOTE

- When the remaining amount of fuel becomes little, the SPORT mode will be automatically cancelled and the message will appear in the multi-information display.

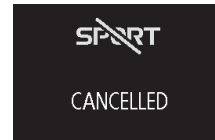

If you want to use the SPORT mode, refuel the vehicle.

- When the following switch is turned on while driving in the SPORT mode, the mode changes to the selected mode.
 - EV switch
 - SAVE/CHARGE mode switch
 - Drive mode switch
 - ECO mode switch

Acoustic Vehicle Alerting System (AVAS)

E00631601107

The Acoustic Vehicle Alerting System (AVAS) is a device that uses sound to alert pedestrians of the presence of the vehicle. The system operates when the vehicle speed is approximately 35 km/h (22 mph) or less and the engine is not running.

The sound starts when the AVAS is operated in the following conditions.

- When the vehicle speed is approximately 3 km/h (2 mph) or less with engine not running and the brake pedal is not depressed.
- When the vehicle speed is approximately 3 km/h (2 mph) to 35 km/h (22 mph) and engine is not running.

The sound does not start in the following cases.

- When the vehicle speed is approximately 3 km/h (2 mph) or less and the brake pedal is depressed.
- When the vehicle speed is approximately 35 km/h (22 mph) or more.
- When the select position is in the "P" (PARK) position.
- When the AVAS OFF indicator in the meter is illuminating.
- When the engine is running.

When the operation mode is set to “ON”, the AVAS OFF indicator comes on and goes out after a few seconds.

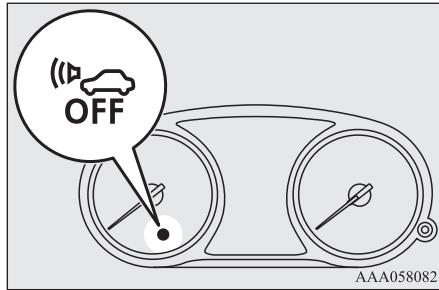

WARNING

- Even if the Acoustic Vehicle Alerting System (AVAS) sounds, pay special attention to pedestrians. Pedestrians may not notice the oncoming vehicle, which may cause an accident resulting in serious personal injury or death.

CAUTION

- Always confirm the indication lamp goes off before driving. If the indication lamp blinks, the operation mode is put in OFF, and the operation mode is put in ON once again. It is normal if the indication lamp goes off. If the indication lamp blinks again, have the vehicle inspected at a MITSUBISHI MOTORS Authorized Service Point as soon as possible.

AVAS OFF switch

E00631701094

If the operation mode is put in ON, the AVAS is automatically turned on.

The AVAS should be turned on while normal driving.

When driving on the freeway etc., it is possible to turn off the AVAS by pressing the AVAS OFF switch.

When pressing the AVAS OFF switch, the audible alarm does not sound and the AVAS OFF indicator illuminates.

Acoustic Vehicle Alerting System (AVAS)

When pressing the AVAS OFF switch once again, the AVAS is activated and the AVAS OFF indicator goes off.

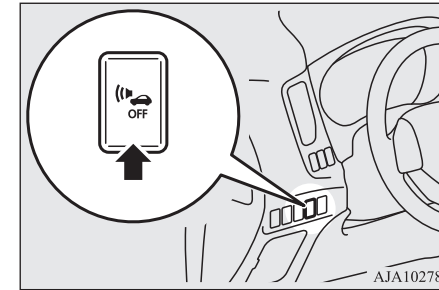

WARNING

- Never turn the Acoustic Vehicle Alerting System (AVAS) off if there is a possibility that pedestrians pass by.

NOTE

- If the operation mode is put in OFF, while the AVAS has been turned off, and the operation mode is put in ON once again, the AVAS is activated.
- If the AVAS OFF switch is continuously pressed after the AVAS is turned off, the incorrect operation prevention function is triggered and the system turns on again.

7

Braking

Braking

E00607003241

All the parts of the brake system are critical to safety. We recommend you to have the vehicle checked at regular intervals according to the service booklet.

CAUTION

- Avoid driving habits that cause heavy braking and never “ride” the brakes by resting your foot on the brake pedal while driving. It causes brake overheating and fade.

7

Brake system

The service brake is divided into two brake circuits. And your vehicle is equipped with power brakes. If one brake circuit fails, the other is available to stop the vehicle. If you should lose the power assist for some reason, the brakes will still work. In these situations, even if the brake pedal moves down to the very end of its possible stroke or resists being depressed, keep depressing the brake pedal down harder and further than usual; stop driving as soon as possible and have the brake system repaired.

WARNING

- Do not turn off the Plug-in Hybrid EV System while your vehicle is in motion. If you turn off the Plug-in Hybrid EV System while driving, the power assistance for the braking system will stop working and your brakes will not work effectively.
- If the power assist is lost or if either brake hydraulic system stops working properly, have your vehicle checked immediately.

Warning display

The brake warning lamp illuminates to indicate a fault in the braking system. A warning is also displayed on the multi information display. Refer to “Brake warning lamp (red)” on page 6-55 and “Brake warning display” on page 6-58.

When brakes are wet

Check the brake system while driving at a low speed immediately after starting, especially when the brakes are wet, to confirm they work normally.

A film of water can be formed on the brake discs and prevent normal braking after driving in heavy rain or through large puddles, or after the vehicle is washed. If this occurs, dry the brakes out by driving slowly while lightly depressing the brake pedal.

When driving downhill

WARNING

- Do not leave any objects near the brake pedal or let a floor mat slide under it; doing so could prevent the full pedal stroke that would be necessary in an emergency. Make sure that the pedal can be operated freely at all times. Make sure that the floor mat is securely held in place.

CAUTION

- Put the selector lever to “B” position according to the grade of a slope or the speed in a long downward slope, and use the regenerative brake together. If you depress the brake pedal and slowing down is repeated frequently, the foot brake may be overheated and effectiveness may worsen.

CAUTION

- Effectiveness of the regenerative brake becomes weak when the drive battery is close to full charge and loses its effect at the full charge.
In this case, since the foot brake is effective, use the foot brake and slow down your vehicle speed beforehand.
The energy usage indicator stops swaying in the charge zone closer to full charge. Refer to “Energy usage indicator” on page 6-02
In such case, drive at low speed in advance. And if needed use the foot brake to slow down the vehicle speed before the vehicle speed increases.
The regenerative brake comes to be effective if the drive battery remaining power is consumed.

Brake pad

- Avoid hard braking situations.
New brakes need to be broken-in by moderate use for the first 200 km (124 miles).
- The disc brakes are provided with a warning device which emits a shrieking metallic sound while braking if the brake pads have reached their wear limit. If you hear this sound, have the brake pads replaced immediately.

WARNING

- **Driving with worn brake pads will make it harder to stop, and can cause an accident.**

Brake auto hold

E00652000136

When the vehicle is stopped at traffic signals etc., the vehicle can be held stationary with the brake auto hold system even if you release your foot from the brake pedal.
When the accelerator pedal is depressed, the brakes are released.

WARNING

- Do not overly rely on the brake auto hold system. On a steep slope, depress the brake pedal firmly because the system may not hold the vehicle stationary.
- Never leave the vehicle while it is being stopped by the brake auto hold system. When leaving the vehicle, apply the parking brake and put the select position to the “P” (PARK) position.
- Do not use the brake auto hold system when driving on slippery roads. The system may not hold the vehicle stationary and an accident could occur.

NOTE

- While operating the brake auto hold system, you may hear an operation noise to increase braking force when the system detected the movement of the vehicle. This does not indicate a malfunction.

How to use brake auto hold

To turn on brake auto hold

7

If the brake auto hold switch is pressed while all of the following conditions are met, the system will change to the standby state and the indication lamp (A) on the switch comes on.

- The operation mode of the power switch is in the “ON” position.
- The driver’s seat belt is fastened.
- The driver’s door is closed.

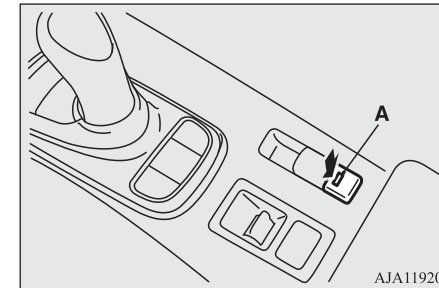

Brake auto hold

NOTE

- When the brake auto hold system cannot be used, a buzzer will sound and the following warning will appear on the information screen in the multi information display.
 - If this warning appears, confirm that all of the conditions for system operation are met and that there is no malfunction in the system.

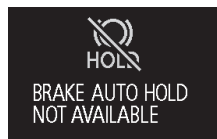

- If this warning appears, fasten the driver's seat belt.

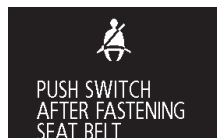

- If any of the following occurs while the system is standby state, the brake auto hold system will be turned off automatically and the indication lamp on the switch goes off. A buzzer will sound and the message will appear on the information screen in the multi information display.
 - When the driver's seat belt is unfastened.
 - When the driver's door is opened.

NOTE

- When there is a malfunction in the system.

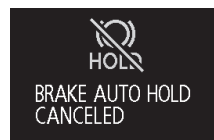

- If you keep pressing the brake auto hold switch after setting the brake auto hold to ON (stand by), the brake auto hold will return to OFF as a protection function is operated.

After returning to OFF, the brake auto hold will not be switched to ON (stand by) even if the brake auto hold switch is pressed. To set the brake auto hold to ON, restart the Plug-in hybrid EV system and press the brake auto hold switch again.

To activate brake auto hold

When the vehicle is stopped by depressing the brake pedal with the select position in any position other than "P" (PARK) or "R" (REVERSE), the brake auto hold activates and the vehicle will be held stationary.

The brake auto hold indication lamp in the instrument cluster will come on while the system activates.

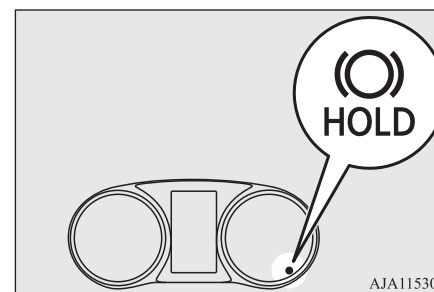

CAUTION

- Release the brake pedal after the brake auto hold indication lamp is illuminated.

NOTE

- In the following situations, the brake auto hold system may not operate temporarily.
 - The vehicle is stopped on a slippery road.
 - The vehicle was stopped while the steering wheel was turned all the way to the left or right.
 - The vehicle is being turned on a parking lot turntable.
- If this occurs, the brake auto hold system will return to the normal operation if you de-

NOTE

press the accelerator pedal and the vehicle starts moving again.

- If the following operation is performed, the brake auto hold will be deactivated and the brake auto hold indication lamp in the instrument cluster goes off.
 - When putting the select position to the “P” (PARK) or “R” (REVERSE) position while depressing the brake pedal.
 - When the Electric parking brake is applied by using the Electric parking brake switch.
- While the vehicle is held stationary with the brake auto hold system, the Electric parking brake will be automatically applied under the following conditions, and a buzzer will sound and the message will appear on the information screen in the multi information display.
 - After approximately 10 minutes have elapsed while applying the brake auto hold system.
 - When the driver’s seat belt is unfastened.
 - When the driver’s door is opened.
 - When the operation mode of the power switch is put in OFF.

NOTE

- When the system detects the vehicle sliding down a slope.

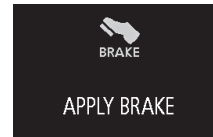

If the Electric parking brake cannot be applied automatically due to the system malfunction, the message will appear on the information screen in the multi information display. Depress the brake pedal.

**To start the vehicle**

Depress the acceleration pedal with the select position in any position other than “P” (PARK) or “N” (NEUTRAL).

The brakes are released, and the brake auto hold indication lamp in the instrument cluster will go off.

To turn off brake auto hold

Press the brake auto hold switch to turn brake auto hold off. The indication lamp on the switch goes off.

If you want to turn off the system while the brake auto hold indication lamp is illuminated, press the switch while depressing the brake pedal.

NOTE

- If the brake auto hold system is turned off without the brake pedal being depressed, a buzzer will sound and the message will appear on the information screen in the multi information display.

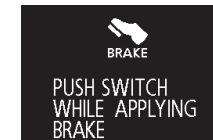
**7****Hill start assist**

E00628001237

The hill start assist makes it easy to start off on a steep uphill slope by preventing the vehicle from moving backwards. It keeps the braking force for about 2 seconds when you move your foot from the brake pedal to the accelerator pedal.

Hill start assist

CAUTION

- Do not overly rely on the hill start assist to prevent backwards movement of the vehicle. Under certain circumstances, even when hill start assist is activated, the vehicle may move backwards if the brake pedal is not sufficiently depressed, if the vehicle is heavily loaded, or if the road is very steep or slippery.
- The hill start assist is not designed to keep the vehicle stopped in place on uphill slopes for more than 2 seconds.
- When facing uphill, do not rely on using the hill start assist to maintain a stopped position as an alternative to depressing the brake pedal. Doing so could result in an accident.
- Do not turn the operation mode in ACC or OFF while the hill start assist is operating. The hill start assist could stop operating, which could result in an accident.

To operate

E00628101498

1. Stop the vehicle completely using the brake pedal.
2. Put the select position to the “D” position.

NOTE

- When reversing on an uphill slope, put the select position to the “R” position.

3. Release the brake pedal and the hill start assist will maintain the braking force applied while stopped for approximately 2 seconds.
4. Depress the accelerator pedal and the hill start assist will gradually decrease the braking force as the vehicle starts moving.

NOTE

- The hill start assist is activated when all of the following conditions are met.
 - The Plug-in Hybrid EV System is operating. (The hill start assist will not be activated while the Plug-in Hybrid EV System is starting or immediately after the Plug-in Hybrid EV System has started.)
 - The select position is in any position other than “P” or “N”.
 - The vehicle is completely stationary, with the brake pedal depressed.
 - The parking brake is released.
- The hill start assist will not operate if the accelerator pedal is depressed before the brake pedal is released.
- The hill start assist also operates when reversing on an uphill slope.

Warning display

E00628201369

If an abnormal condition occurs in the system, the following Warning lamp/Warning display will turn on.

Warning lamp



Warning display



CAUTION

- If the warning is displayed, the hill start assist will not operate. Start off carefully.
- Park your vehicle in a safe place and stop the Plug-in Hybrid EV System. Restart the Plug-in Hybrid EV System and check whether the display/indicator goes out, in which case the hill start assist is working normally again. If they remain displayed or reappear frequently, it is not necessary to stop the vehicle immediately, but the vehicle should be inspected by a MITSUBISHI MOTORS Authorized Service Point as soon as possible.

Brake assist system

E00627001793

The brake assist system is a device assisting drivers who cannot depress the brake pedal firmly when it is necessary to do so (such as in emergency stop situations) and provides greater braking force.

If the brake pedal is depressed suddenly, the brakes will be applied with more force than usual.

CAUTION

- The brake assist system is not a device designed to exercise braking force greater than its capacity. Make sure to always keep a sufficient distance between your vehicle and a vehicle in front of you without relying too much on the brake assist system.

NOTE

- Once the brake assist system is operational, it maintains great braking force even if the brake pedal is lightly released. To stop its operation, completely remove your foot from the brake pedal.

NOTE

- When the brake assist system is in use, you may feel as if the depressed brake pedal is soft, the pedal moves in small motions in conjunction with the sound of the ABS operation, or the vehicle body and the steering wheel vibrate. This occurs when the brake assist system is operating normally and does not indicate faulty operation. Continue to firmly depress the brake pedal.
- You may hear an operation noise when the brake pedal is depressed suddenly while stationary. This does not indicate a malfunction and the brake assist system is operating normally.
- When the anti-lock brake system warning lamp or only Active Stability Control warning lamp illuminate, the brake assist system is not functioning.

Emergency stop signal system

E00626001259

This is a device that reduces the possibility of rear end collisions by the rapid and automatic blinking of the hazard warning lamps to alert vehicles approaching from behind during sudden braking. When the emergency stop signal system operates, the hazard warning indication lamp in the instrument cluster blinks rapidly at the same time.

CAUTION

- If the ABS warning or ASC warning is displayed, the emergency stop signal system may not operate. Refer to “ABS warning lamp/display” on page 7-41. Refer to “ASC warning lamp/display” on page 7-45.

NOTE

- [Activating condition for the emergency stop signal system]
It activates when all of the following conditions are met.
 - The vehicle speed is approximately 55 km/h (34 mph) or higher.
 - The brake pedal has been depressed, and the system judges that it was sudden braking from the vehicle deceleration and the operating condition of the anti-lock brake system (ABS).
- [Deactivating condition for the emergency stop signal system]
It deactivates when one of the following conditions is met.
 - The brake pedal is released.
 - The hazard warning flasher switch is pressed.
 - The system judges that it was not sudden braking from the vehicle deceleration and the operating condition of the anti-lock brake system (ABS).

7

Anti-lock brake system (ABS)

Anti-lock brake system (ABS)

E00607102489

Environmental conditions can have an effect on braking. During sudden braking when there is snow, ice, oil, water etc. on the road surface, a skid may occur. In this situation, steering control and braking effectiveness is reduced and the stopping distance is increased. The vehicle may also go into an uncontrolled spin.

The ABS helps prevent the wheels from locking during braking, thus maintaining directional stability, ensuring controllability and providing optimum braking force.

Operating hints

- Always maintain the same distance from the vehicle in front of you as you would for a vehicle not equipped with ABS. Compared with vehicles not fitted with ABS, your vehicle may require a longer stopping distance in the following cases:
 - Driving on gravel or snow-covered roads.
 - Driving with snow traction device (tyre chains) installed.
 - Driving on roads where the road surface is pitted or has other differences in surface height.

- Driving on bumpy roads or other poor driving surfaces.
- Operation of ABS is not restricted to situations where brakes are applied suddenly. This system may also operate to prevent wheel lock when you are driving over manholes, steel road-work plates, or the vehicle is driven over steps or level differences in the road, road markings, or other surfaces which are difficult for the wheels to grip.
- When the ABS is activated, you may feel the brake pedal pulsation and the vibrations of the vehicle body and steering wheel. You may also hear a characteristic noise. At this time, you may feel as if the pedal attempts to resist being depressed.

This is a normal result of the ABS operation, and does not indicate a problem.

If this situation occurs, depress the brake pedal more firmly in order to operate the ABS. Do not pump the brake. This will result in reduced braking performance.

- You will hear the operation sound of the motor coming from the Plug-in Hybrid EV System compartment immediately following start off after starting the Plug-in Hybrid EV System. If the brake pedal is depressed at that moment, you can feel the brake pedal pulsating. This pulsation is due to the self-diagnosis operation of the ABS and does not indicate a malfunction.
- The ABS will operate after the vehicle has accelerated to a speed in excess of approximately 10 km/h (6 mph). It stops operating when the vehicle decelerates to a speed below about 5 km/h (3 mph).

CAUTION

- Even the ABS cannot prevent the natural laws of physics from acting on the vehicle. It cannot for instance avoid accidents that may result from excessive speed on bends or following another vehicle too closely or aquaplaning. It should remain the driver's task to observe safety precautions to judge speeds and brake applications correctly in such conditions.
- Be sure to use tyres of the same type and size on 4 wheels. If tyre types or sizes are mixed, ABS may not function normally.

⚠ CAUTION

- Never install a limited-slip differential, which is not MITSUBISHI MOTORS GENUINE parts, as the ABS may not function normally.

We recommend you to consult a MITSUBISHI MOTORS Authorized Service Point.

ABS warning lamp/display

E00607202321

Warning lamp



Warning display



If there is a malfunction in the system, the ABS warning lamp will come on and the warning display will appear on the information screen in the multi information display. Under normal conditions, the ABS warning lamp only comes on when the operation mode is put in ON and goes off a few seconds later.

⚠ CAUTION

- Any of the following warning lamp/display behaviour indicates that the ABS is not functioning and only the standard brake system is working. (The standard brake system is functioning normally.) If this happens, take your vehicle to a MITSUBISHI MOTORS Authorized Service Point.
 - When the operation mode is put in ON, the warning lamp does not come on or it remains on and does not go off.
 - The warning lamp comes on while driving.
 - The warning display appears while driving.

If the warning lamp/display illuminate while driving

E00607302494

If only the ABS warning lamp/display illuminate

- Avoid hard braking and high-speed driving. Stop the vehicle in a safe place. Restart the Plug-in Hybrid EV System and check to see whether the lamp goes out after a few minutes driving; if it then remains off during driving, there is no problem. However, if the lamp does not go out, or if it lights up again when the vehicle is driven, we recommend you to have the vehicle checked as soon as possible.

OGGE19E1

- If you start Plug-in Hybrid EV System when the auxiliary battery voltage is insufficient, ABS warning lamp/display may illuminate, but this is not a failure of ABS. When the drive battery is charged, the auxiliary battery is also charged, and the warning lamp/display will go out. If the warning lamp/display continues illuminating even after the battery is sufficiently charged or the warning lamp/display illuminates frequently, have your vehicle inspected by a MITSUBISHI MOTORS Authorized Service Point.

If the ABS warning lamp/display and brake warning lamp (red)/display illuminate at the same time

Warning lamp



(red)

Electric power steering system (EPS)

Warning display



7

The ABS and brake force distribution function may not work, so hard braking could make the vehicle unstable.

Avoid hard braking and high-speed driving. Stop the vehicle in a safe place immediately and contact a MITSUBISHI MOTORS Authorized Service Point.

NOTE

- The ABS warning lamp and brake warning lamp illuminate at the same time and the warning displays appear alternately on the information screen in the multi information display.

After driving on icy roads

E00618801388

After driving on snowy roads, remove any snow and ice which may have become adhered to the wheel areas.

7-42 Starting and driving

When doing this, be careful not to damage the wheel speed sensors (A) and cables located at each wheel on vehicles equipped with an ABS.

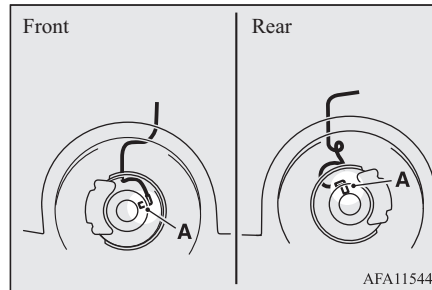

Electric power steering system (EPS)

E00629201294

The power steering system operates while the Plug-in Hybrid EV System is operating. It helps reduce the effort needed to turn the steering wheel.

The power steering system has mechanical steering capability in case the power assist is lost. If the power assist is lost for some reason, you will still be able to steer your vehicle, but you will notice it takes much more effort to steer. If this happens, have your vehicle inspected at a MITSUBISHI MOTORS Authorized Service Point.

OGGE19E1

WARNING

- Do not stop the Plug-in Hybrid EV System while the vehicle is moving. Stopping the Plug-in Hybrid EV System would make the steering wheel extremely hard to turn, possibly resulting in an accident.

NOTE

- During repeated full-lock turning of the steering wheel (for example, while you are manoeuvring the vehicle into a parking space), a protection function may be activated to prevent overheating of the power steering system. This function will make the steering wheel gradually harder to turn. In this event, limit your turning of the steering wheel for a while. When the system has cooled down, the steering action will return to normal.
- If you turn the steering wheel while the vehicle is stationary with the headlamps on, the headlamps may become dim. This behaviour is not abnormal. The headlamps will return to their original brightness after a short while.

Electric power steering system warning display



If there is a malfunction in the system, the warning display will appear on the information screen in the multi information display.

⚠ CAUTION

- If the warning display appears while the Plug-in Hybrid EV System is operating, have the vehicle inspected by a MITSUBISHI MOTORS Authorized Service Point as soon as possible. It may become harder to turn the steering wheel.

Active stability control (ASC)

E00616701468

The Active Stability Control (ASC) takes overall control of the anti-lock brake system, traction control function and stability control function to help maintain the vehicle's control and traction. Please read this section in conjunction with the page on the anti-lock brake system, traction control function and stability control function.

Anti-lock brake system (ABS) → p. 7-40

Traction control function → p. 7-44

Stability control function → p. 7-44

⚠ CAUTION

- Do not over-rely on the ASC. Even the ASC cannot prevent the natural laws of physics from acting on the vehicle. This system, like any other system, has limits and cannot help you to maintain traction and control of the vehicle in all circumstances. Reckless driving may lead to accidents. It is the driver's responsibility to drive carefully. This means taking into account the traffic, road and environmental conditions.
- Be sure to use the same specified type and size of tyre on all 4 wheels. Otherwise, the ASC may not work properly.

⚠ CAUTION

- Do not install any aftermarket limited-slip differential (LSD) on your vehicle. The ASC may stop functioning properly.

📖 NOTE

- An operation noise may be emitted from the Plug-in Hybrid EV System compartment in the following situations. The sound is associated with checking the operations of the ASC. At this time, you may feel a shock from the brake pedal if you depress it. These do not indicate a malfunction.
 - When the operation mode is put in ON.
 - When the vehicle is driven for a while after the Plug-in Hybrid EV System is turned on.
- When the ASC is activated, you may feel a vibration in the vehicle body or hear a whining sound from the Plug-in Hybrid EV System compartment. This indicates that the system is operating normally. It does not indicate a malfunction.
- When the anti-lock brake system warning lamp is illuminated, the ASC is not active.

7

Active stability control (ASC)

Traction control function

E0061900087

On slippery surfaces, the traction control function prevents the drive wheels from excessive spinning, thus helping the vehicle to start moving from a stopped condition. It also provides sufficient driving force and steering performance as the vehicle turns while pressing the acceleration pedal.

7

CAUTION

- When driving a vehicle on a snowy or icy road, be sure to install snow tyres and drive the vehicle at moderate speeds.

Stability control function

E00619101098

The stability control function is designed to help the driver maintain control of the vehicle on slippery roads or during rapid steering manoeuvres. It works by controlling the Plug-in Hybrid EV System output and the brake on each wheel.



NOTE

- The stability control function operates at speeds of about 15 km/h (9 mph) or higher.

ASC OFF switch

E00619201871

The ASC is automatically activated when the operation mode is put in ON. You can deactivate the system by pressing down the ASC OFF switch for 3 seconds or longer.

When the ASC is deactivated, the  display/indicator will turn on. To reactivate the ASC, momentarily press the ASC OFF switch; the  indicator is turned off.

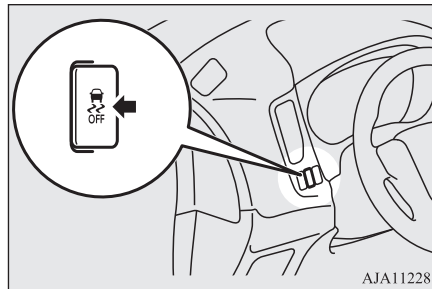

CAUTION

- For safety reasons, the ASC OFF switch should be operated when your vehicle is stopped.
- Be sure to keep the ASC on while driving in normal circumstances.

CAUTION



- In case you turn off the ASC to move out from mud or sand etc., press the ASC OFF switch to activate the ASC quickly after moving out, and do not turn off the ASC unless it is necessary.
- If you continue to race the tyre by depressing the accelerator pedal too much while ASC is turned off, parts such as the transaxle may be damaged and this could lead to an accident.

NOTE

- When moving out of mud, sand or fresh snow, pressing the accelerator pedal may not allow the Plug-in Hybrid EV System output to increase. In such situations, switching to “LOCK” with the Drive mode switch and temporarily turning off the Active Stability Control (ASC) with the ASC OFF switch will make it easier to move out your vehicle. Refer to “Operation under adverse driving conditions: If your vehicle becomes stuck in sand, mud or snow” on page 9-21.
- By pressing the “ASC OFF” switch, both the stability control function and the traction control function are turned OFF.
- If you continue to press the ASC OFF switch after the ASC is turned off, the “mistaken operation protection function” will activate and the ASC will turn back on.

ASC operation indicator or ASC OFF indicator



E00619301771

-  - ASC operation indicator
The indicator will blink when the ASC is operating.
-  - ASC OFF indicator
This indicator will turn on when the ASC is turned off with the ASC OFF switch.

CAUTION

- When  indicator blinks, ASC is operating, which means that the road is slippery or that your vehicle's wheels are beginning to slip. If this happens, drive slower with less accelerator input.

CAUTION

- If the temperature in the braking system continues to increase due to continuous brake control on a slippery road surface, the  indicator will blink. To prevent the brake system from overheating, the brake control of the traction control function will be temporarily suspended.
The Plug-in Hybrid EV System control of the traction control function and normal brake operation will not be affected. Park your vehicle in a safe place. When the temperature in the braking system has come down, the  indicator will be turned off and the traction control function will start operating again.

NOTE

- The  indicator may turn on when you start the Plug-in Hybrid EV System. This means that the battery voltage momentarily dropped when the Plug-in Hybrid EV System was started. It does not indicate a malfunction, provided that the indicator goes out immediately.



ASC warning lamp/display

E00619401655

If an abnormal condition occurs in the system, the following warning lamp/warning display will turn on.

Warning lamp

OGGE19E1

-  - ASC operation indicator
-  - ASC OFF indicator

Warning display



7

CAUTION

- The system may be malfunctioning. Park your vehicle in a safe place and stop the Plug-in Hybrid EV System. Restart the Plug-in Hybrid EV System and check whether the display/indicator goes out. If they go out, there is no abnormal condition. If they do not go out or appear frequently, it is not necessary to stop the vehicle immediately, but we recommend you to have your vehicle inspected.

Cruise control*

E00609102584

Cruise control is an automatic speed control system that keeps a set speed. It can be activated at approximately 40 km/h (25 mph) or more.

Starting and driving 7-45

Cruise control*

CAUTION

- When you do not wish to drive at a set speed, turn off the cruise control for safety.
- Do not use cruise control when driving conditions will not allow you to stay at the same speed, such as in heavy traffic or on roads that are winding, icy, snow-covered, wet, slippery, on a steep downhill slope.

NOTE

7

- Cruise control may not be able to keep your speed on uphill or downhill.
- Your speed may decrease on a steep uphill. You may use the accelerator pedal if you want to stay at your set speed.
- Your speed may increase to more than the set speed on a steep downhill. You must use the brake to control your speed. As a result, the set speed driving is deactivated.
- The regenerative level B0 or B1 cannot be selected under the cruise control. The buzzer sounds if you try to select these levels.

Cruise control switches

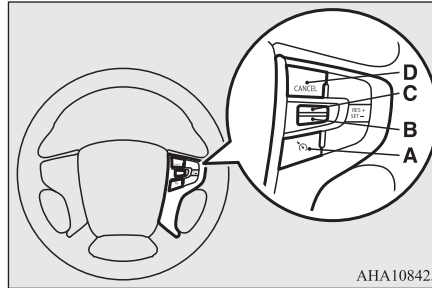

A- CRUISE CONTROL ON/OFF switch

Used to turn on and off the cruise control.

B- "SET -" switch

Used to reduce the set speed and to set the desired speed.

C- "RES +" switch

Used to increase the set speed and to return to the original set speed.

D- "CANCEL" switch

Used to deactivate the set speed driving.

NOTE

- When operating the cruise control switches, press the cruise control switches correctly. The set speed driving may be deactivated automatically if two or more switches of the cruise control are pressed at the same time.

To activate

E00609302690

1. With the operation mode in ON, press the CRUISE CONTROL ON/OFF switch (A) to turn on the cruise control. The indicator display in the meter cluster will come on.

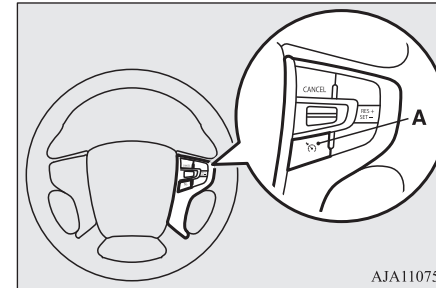

- Accelerate or decelerate to your desired speed, then push down and release the "SET -" switch (B). The vehicle will then maintain the desired speed. The "SET" indicator appears on the information screen in the meter cluster.

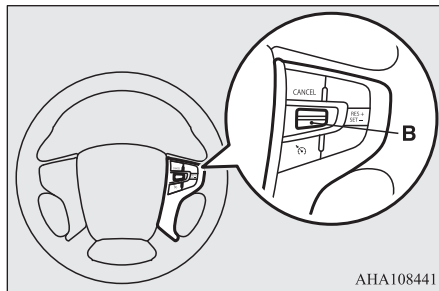

NOTE

- When you release the "SET -" switch (B), the vehicle speed will be set.

To increase the set speed

E00609402008

There are 2 ways to increase the set speed.

"RES +" switch

Push up and hold the "RES +" switch (C) while driving at the set speed, and your speed will then gradually increase.

When you reach your desired speed, release the switch. Your new cruising speed is now set.

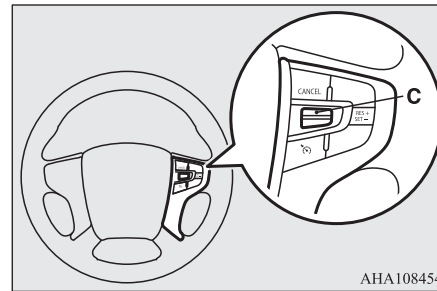

To increase your speed in small amounts, push up the "RES +" switch (C) for less than approximately 1 second and release it. Each time you press the "RES +" switch (C), your vehicle will go approximately 1.6 km/h (1 mph) faster.

Accelerator pedal

While driving at the set speed, use the accelerator pedal to reach your desired speed and then push down the "SET -" switch (B) and release the switch momentarily to set a new desired cruising speed.

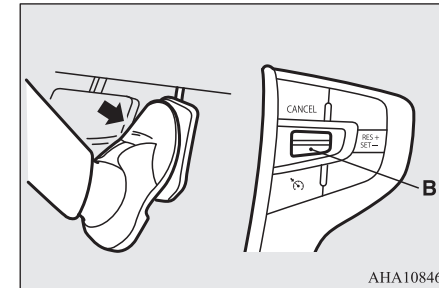

7

To decrease the set speed

E00609501930

There are 2 ways to decrease the set speed.

"SET -" switch

Push down and hold the "SET -" switch (B) while driving at the set speed, and your speed will slow down gradually.

Cruise control*

When you reach your desired speed, release the switch. Your new cruising speed is now set.

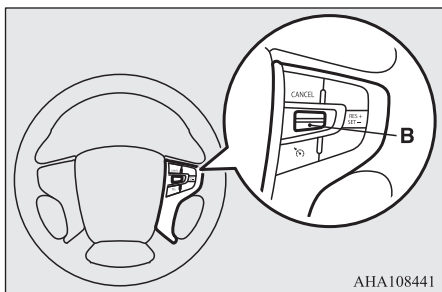

To slow down your speed in small amounts, push down the "SET -" switch (B) for less than approximately 1 second and release it. Each time you push down the "SET -" switch (B), your vehicle will slow down by approximately 1.6 km/h (1 mph).

Brake pedal

While driving at the set speed, use the brake pedal, which disengages the cruise control, then push down the "SET -" switch (B) and release the switch momentarily to set a new desired cruising speed.

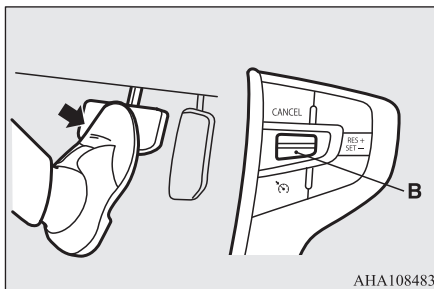

To temporarily increase or decrease the speed

E00609601481

To temporarily increase the speed

Depress the accelerator pedal as you would normally. When you release the pedal, you will return to your set speed.

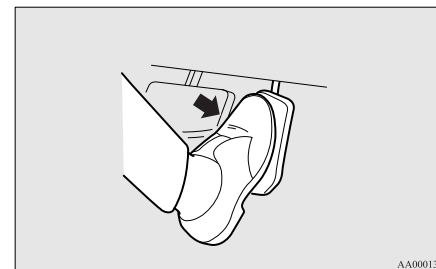

NOTE

- In some driving conditions, the set speed driving may be deactivated. If this happens, refer to "To activate" on page 7-46 and repeat the speed setting procedure.

To temporarily decrease the speed

Depress the brake pedal to decrease the speed. To return to the previously set speed, push up the "RES +" switch (C).

Refer to “To resume the set speed” on page 7-50.

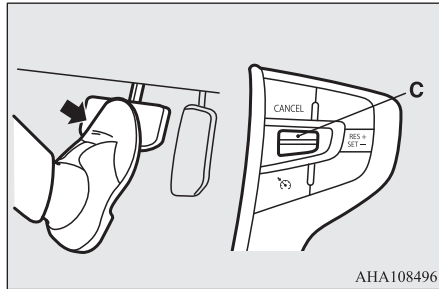

To deactivate

The set speed driving can be deactivated as follows:

- Press the CRUISE CONTROL ON/OFF switch (A) (Cruise control will be turned off.)
- Press the “CANCEL” switch (D).

- Depress the brake pedal.

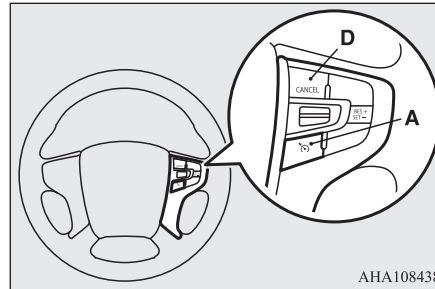

The set speed driving is deactivated automatically in any of the following ways.

- When your speed slows to approximately 15 km/h (9 mph) or more below the set speed because of a hill, etc.
- When your speed slows to approximately 40 km/h (25 mph) or less.
- When the Active Stability Control (ASC) starts operating. Refer to “Active stability control (ASC)” on page 7-43.

WARNING

- Although the set speed driving will be deactivated when shifting to the “N” (NEUTRAL) position, never move the selector lever to the “N” (NEUTRAL) position while driving. You would have no regenerative brake and could cause a serious accident.

CAUTION

- When the set speed driving is deactivated automatically in any situation other than those listed above, there may be a system malfunction. Press the CRUISE CONTROL ON/OFF switch to turn off the cruise control and have your vehicle inspected by a MITSUBISHI MOTORS Authorized Service Point.

NOTE

- You cannot operate the regenerative brake while the adaptive cruise control system (ACC) is operating.
- If you perform the following operation, the buzzer may sound and the select position may automatically shift to “N” position.
 - The electrical parking switch is pressed during driving.
 - The selector lever is shifted to “R” during driving forward.
 - The selector lever is shifted to “D” during driving backward.

Speed Limiter*

NOTE

- The selector lever is shifted to “B” when the select position is in “R”.

To resume the set speed

E00609802161

If the set driving speed is deactivated by the condition described in “To deactivate” on page 7-49, you can resume the previously set speed by pushing up the "RES +" switch (C) while driving at a speed of approximately 40 km/h (25 mph) or higher. The “SET” indicator appears on the information screen in the meter cluster.

7

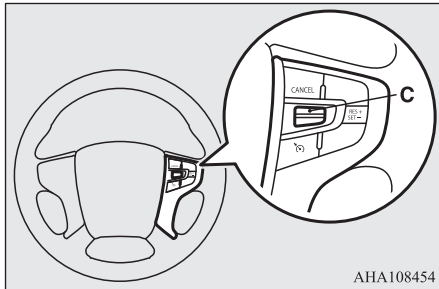

Under either of the following conditions, however, using the switch does not allow you to resume the previously set speed. In these situations, repeat the speed setting procedure:

- The CRUISE CONTROL ON/OFF switch is pressed.
- The operation mode is put in OFF.
- The indicator display goes off.

Speed Limiter*

E00633201093

The Speed Limiter is a driver assist function to prevent from exceeding the speed set by driver while Plug-in Hybrid EV System power control.

CAUTION

- Because the system does not use service brake (hydraulic brake), the vehicle speed may exceed the set speed on the downhill. If a driver wants to keep the vehicle speed in such a situation, he/she must put on a service brake.

If the vehicle speed exceeds the set speed (about 3 km/h (2 mph)), the indicator will blink in the combination meter.

If the vehicle speed exceeds the set speed about +3 km/h (2 mph) more than about 5 seconds after indicated alert message, beep alert is sounded for about 10 seconds at the most.

While running without alert message, if you decrease the set speed and vehicle speed is more than set speed about +3 km/h (2 mph), alert message is displayed but beep alert is delayed.

In this case, when vehicle speed keeps exceeding set speed about +3 km/h (2 mph) for about 30 seconds after the alert message is appeared, beep alert is sounded for about 10 seconds at the most.

If the vehicle speeds decreases less than set speeds after the alert message is appeared, the message is disappeared. When beep alert is sounding, the beep alert also goes off.

NOTE

- However, this gives priority to audio and visual signal of safety reasons or driver's demand.

Speed Limiter control switches

E00633301052

There are 4 switches which relate to the Speed Limiter on the steering wheel.

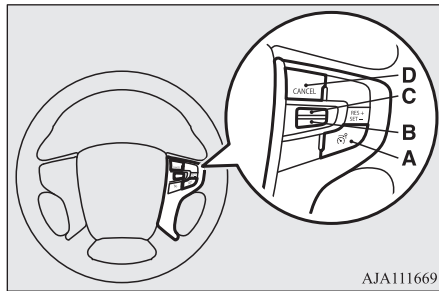

AJA111669

A- SPEED LIMITER ON/OFF switch

To turn on/off the Speed Limiter.

B- SET - switch

To set the current vehicle speed to a set speed decrease the set speed.

C- RES + switch

To resume the Speed Limiter with set speed memorized or increase the set speed.

D- CANCEL switch

To cancel the Speed Limiter.

NOTE

- Press the switch one by one.

NOTE

- The Speed Limiter may be cancelled automatically, if two or more switches are pressed at the same time.

Speed Limiter information on the multi information display area

E00633401037

The Speed Limiter information is displayed on the multi information display area in the combination meter.

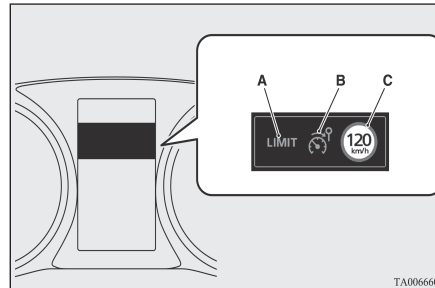

TA0066603

A- Control state

There are 3 control states as below.

LIMIT OFF

When the Speed Limiter is in STANDBY, the vehicle speed can exceed the set speed

LIMIT

When the Speed Limiter is in operation. The vehicle is controlled in order not to exceed the set speed.

OVER LIMIT

When the vehicle speed is exceeding the set speed by more than about 3 km/h (2 mph)

B- SPEED LIMITER ON indication

When the Speed Limiter is started up, the Speed Limiter's symbol appears.

C- Set speed

Set speed appears if it is stored.

7

To start up

E00633501025

First of all, press the ON/OFF switch in order to power up the Speed Limiter when the operation mode in ON.

The Speed Limiter indication will be appeared in the combination meter.



Speed Limiter*

To activate

E00633601055

Accelerate or decelerate to your desired speed, and push down the SET - switch (B). the Speed Limiter memorizes the current vehicle speed when you release the SET - switch (B). Now, the Speed Limiter starts controlling in order not to exceed the set speed.

7

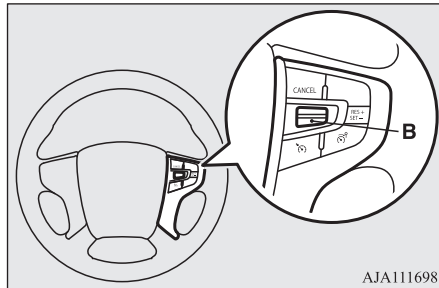

If the current vehicle speed is lower than about 30 km/h (19 mph) (settable minimum speed), the set speed is set at about 30 km/h (19 mph).

The set speed is displayed in the combination meter.

And, control state "LIMIT" is displayed in the combination meter.



To increase the set speed

E00633700017

By using the RES + switch

E00633801044

Push up the RES + switch continuously.

Then the set speed displayed in the combination meter is gradually increased. If the set speed reaches your desired speed, release the RES + switch (C).

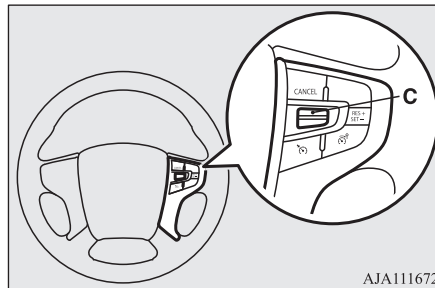

The set speed is increased each about 5 km/h (3 mph) per about 0.5 second.

If a driver wants to increase the set speed a little, push up RES + switch for less than about 0.5 second and release it.

The set speed is increased 1 km/h (1 mph) each taps.

By using the CANCEL switch, the accelerator pedal and the SET - switch

E00633901058

Press the CANCEL switch (D) to deactivate the Speed Limiter.

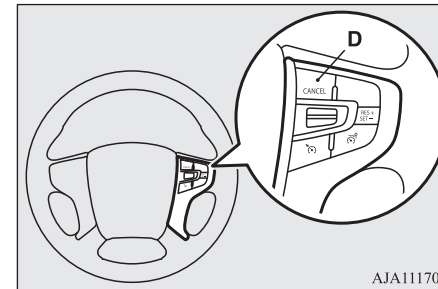

Control state "LIMIT" is disappeared and change control state "LIMIT OFF" in the combination meter.



Accelerate to driver's desired vehicle speed and push down SET - switch (B) and release.

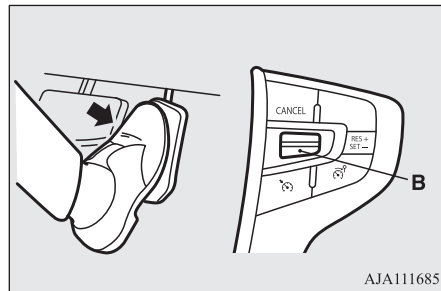

If the set speed reaches to your desired speed, release the SET - switch (B).

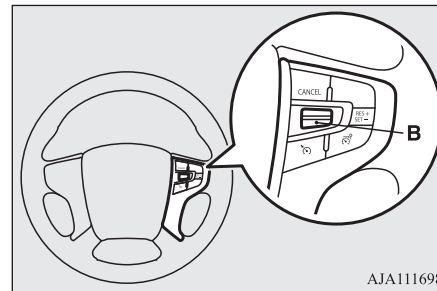

By using the CANCEL switch, the service brake and the SET - switch

E00634201058

Press the CANCEL switch (D) to deactivate the Speed Limiter.

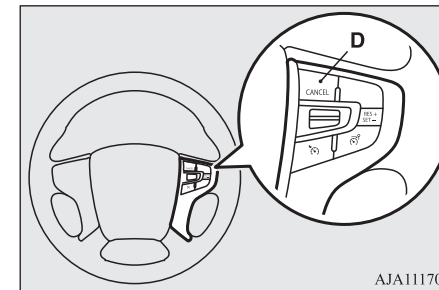

7

Control state "LIMIT" is displayed again and the set speed is updated.

To decrease the set speed

E00634000017

By using the SET - switch

E00634101044

Push down the SET - switch (B).

The set speed decrease about 5 km/h (3 mph) per about 0.5 second.

If a driver wants to decrease the set speed a little, press SET - switch (B) for less than about 0.5 second and release it.

The set speed is decreased 1 km/h (1 mph) each taps.

Control state "LIMIT" is disappeared and change control state "LIMIT OFF" in the combination meter.



Then the set speed displayed in the combination meter is gradually decreased.

Speed Limiter*

Decelerate to driver's desired speed and push down SET-switch - (B) and release.

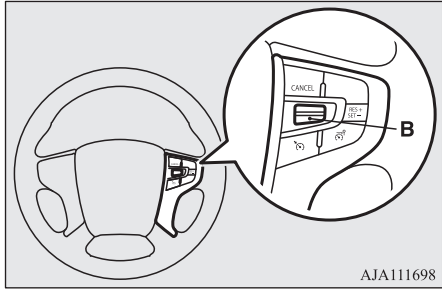

7

The Speed Limiter indication is displayed again and the set speed is updated.

To increase the vehicle speed temporarily

E00634301020

A driver can temporarily accelerate for emergency use.

The Speed Limiter is temporarily deactivated, and the vehicle speed can be increased.

The Speed Limiter will resume when the vehicle speed goes down to enough less than the set speed.

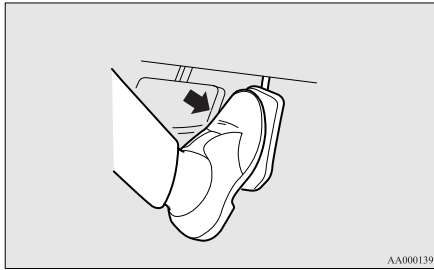

Put on an accelerator pedal to the pedal stroke end. (over a detent that makes pedal reaction force bigger before pedal stroke end)

CAUTION

- There is a possibility for the Speed Limiter to allow abrupt acceleration corresponding to accelerator pedal position. So be careful of the abrupt acceleration.

If vehicle speed exceeds set speed about +3 km/h (2 mph), alert messages are appeared in the combination meter.



CAUTION

- Be careful about over speed.

NOTE

- A driver can change the set speed during this emergency use.

To deactivate

E00634401122

Use whichever following ways to deactivate.

- Press CANCEL switch
- Press the Speed Limiter ON/OFF switch
- If CRUISE CONTROL ON/OFF switch or ACC ON/OFF switch is pressed, the Speed Limiter will be cancelled.

CAUTION

- There is a possibility for the Speed Limiter to allow abrupt acceleration corresponding to accelerator pedal position when the Speed Limiter is deactivated. Be careful.

NOTE

- If the Speed Limiter is cancelled by other states, it may be a system malfunction. Stop using the Speed Limiter and turn off the Speed Limiter. Have your vehicle inspected by a MITSUBISHI MOTORS Service Point.

To resume

E00634501048

The Speed Limiter memorizes the set speed when system has been deactivated, the Speed Limiter can resume by push up the RES + switch (C).

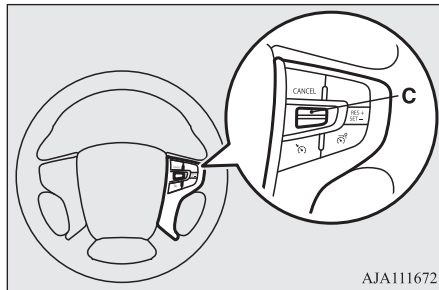

However, the Speed Limiter immediately starts controlling and the vehicle decreases as if an accelerator pedal is closed fully, when the vehicle speed is higher than the set speed.

CAUTION

- There is a possibility to occur jerk, depending on a running resistance. Be careful.

Adaptive Cruise Control System (ACC)*

E00634601401

The ACC maintains a set speed with no need for you to use the accelerator pedal. Using a sensor (A), the system also measures the relative speed and distance between your vehicle and a vehicle in front, and maintains a set following distance between your vehicle and the vehicle in front by automatically decelerating your vehicle if it becomes too close to the vehicle in front.

The ACC is the driver assist system to make comfortable on a freeway. Stop lamps are illuminated during automatic braking.

Adaptive Cruise Control System (ACC)*

If you desire, a cruise control without intervention of the following distance control is also selectable.

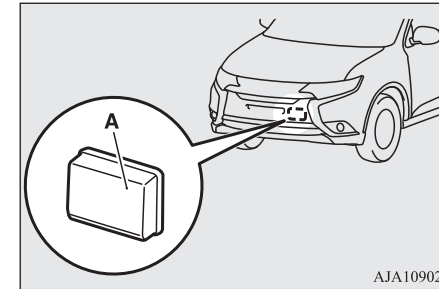

WARNING

- A driver is responsible for driving safely. Even if the ACC is in use, always grasp the surrounding circumstances and provide for safe driving.
- Never rely solely on the ACC. The ACC is the system to reduce load on the driver. The ACC is not a collision avoidance system or an automatic driving system. The system is not intended to compensate for driver's loss of attention to the front during driving due to distraction or carelessness or supplement a drop in visibility due to the rain and fog. It is never a substitute for your safe and careful driving. Always be ready to apply the brakes manually.

7

Adaptive Cruise Control System (ACC)*

⚠ WARNING

- This system may not correctly detect the actual situation depending on the type of vehicle in front and its conditions, the weather conditions, and the road conditions.

Additionally, the system may be unable to decelerate sufficiently if the vehicle in front applies the brakes suddenly or another vehicle cuts into your path, so your vehicle approaches the front vehicle.

Improper usage of this system or loss of attention to the front by the over-rely on the ACC, may result in a serious accident.

7

⚠ CAUTION

- In the following situations, the system may become transiently unable to detect a vehicle in front or triggers its control and alarm functions by detecting something other than a vehicle in front.

⚠ CAUTION

- When driving in curved sections of road including their entrance/outlet or running beside a closed lane in a traffic work or similar zone.

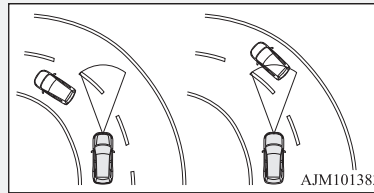

- When your vehicle position in a lane is unstable, is frequently steered to right and left, or running unstably due to a traffic accident, trouble with some vehicles, etc.
- When driving on the road that the vehicle in front runs in offset position from your vehicle.

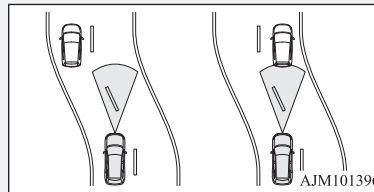

- Never use the ACC in any of the following situations. Failure to follow this instruction could lead to an accident.
 - On roads with heavy traffic or roads including many windings or steep curves.

⚠ CAUTION

- On roads with slippery surfaces, such as frozen, snow-covered, and dirt roads.
- Under adverse weather conditions (rain, snow, sand storms, etc.).
- On steep downslopes.
- On roads including steep up and down slopes or many changes in inclination.
- In traffic requiring frequent acceleration and deceleration.
- When the proximity alarm sounds frequently.
- When your vehicle is towed or your vehicle tows another vehicle.
- When your vehicle is on a chassis dynamometer or free rollers.
- When the air pressure in the tyres is not correct.
- When snow traction device (tyre chains) are attached.
- Be sure to take the following precautions to keep the system in good operating conditions. Improper handling of the system components may result in degraded sensor performance.
 - Avoid application of strong shock loads to the sensor and never tamper with or remove the sensor mounting screws.
 - The cover in front of the sensor and the sensor should be kept clean.

⚠ CAUTION

- Do not cover the sensor mounted area (shaded area as shown in the illustration) with a sticker, licence plate or anything such as a grill guard, etc.

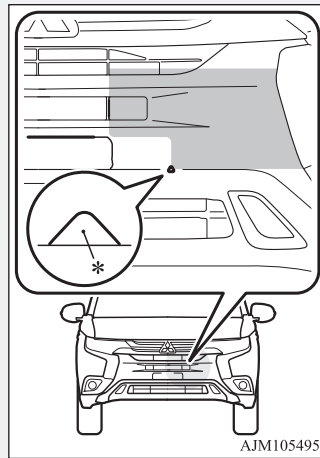

- The sensor front cover should not be modified or painted.
- Avoid using different size tyres from those specified and maintain even tyre wear.
- Do not modify the suspension of your vehicle.

⚠ CAUTION

- When the cover in front of the sensor or the sensor is deformed by an accident, please do not use the ACC and contact a MITSUBISHI MOTORS Authorized Service Point.

📖 NOTE

- You cannot operate the regenerative brake controls while the ACC is operating. If doing so, the buzzer sounds.
- If you turn on the ACC when the select position is in "B" (including B0 to B5) position, the select position is changed to "D" position.

When ACC detects no vehicle in front within the set distance

Your vehicle runs at a speed to which you set. It is possible to set the speed between approximately 40 km/h (25 mph) and 180 km/h (112 mph).

📖 NOTE

- If the vehicle speed exceed the set speed on down slope, the system automatically applies the brake to maintain the vehicle speed.

Adaptive Cruise Control System (ACC)*

📖 NOTE

- When depressing the brake pedal while automatic brake is applied, the brake pedal is felt solidly, but it is not abnormal. You can more depress the pedal and it provides greater braking force.
- Sound is heard while automatic brake, but it is operated a brake control and not abnormal.

When ACC detects a vehicle in front within the set distance

7

The ACC makes control to maintain a following distance (time gap) matched with the vehicle speed between your vehicle and a vehicle in front while also activating brakes as necessary.



If the vehicle in front stops, the ACC reacts to it by stopping your vehicle. Depress the brake pedal as soon as your vehicle comes to a stop.

Adaptive Cruise Control System (ACC)*



7

CAUTION

- Never leave the vehicle when it is stopped by automatic braking.

NOTE

- If you do not depress the brake pedal within 2 seconds after an automatic stop, you are alerted to automatic cancellation of the ACC by a buzzer and display message and the ACC shift into the 'standby state'. The vehicle will then start creeping as the brakes are released.

When the ACC no longer detects any vehicle in front, a buzzer sounds and the symbol of vehicle running ahead disappears from the screen. The vehicle is slowly accelerated to resume the set speed and continues running at that speed.

WARNING

- Your vehicle may accelerate up to the set speed in the following situations. Apply the brake, if necessary, to slow down.
 - When your vehicle no longer follows the vehicle in front, e.g. at a freeway exit or when your vehicle or the vehicle in front changes its lane.

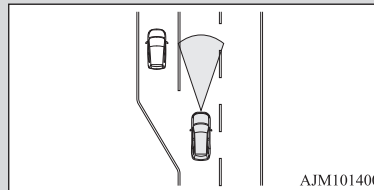

WARNING

- When driving on a curve.



- If the vehicle in front turns off or changes lane and another stationary vehicle is located in front of that vehicle, the ACC will not make deceleration control to the stationary vehicle.

Proximity alarm

E00634701079

While the ACC is active, if your vehicle approaches too closely to a vehicle in front because the ACC cannot allow for an adequate deceleration in such cases as rapid deceleration of the vehicle in front or apparition of a vehicle cutting in front of your vehicle, the ACC gives a warning by sounding a buzzer and displaying a message.

If this happens, increase the following distance by depressing the brake pedal or making other decelerating control.

Adaptive Cruise Control System (ACC)*

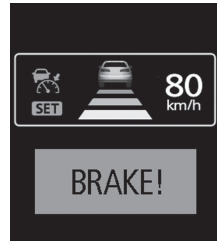

CAUTION

- When the ACC is not in use, turn off the system to prevent it from operating by mistake and an unexpected accident.
- Never operate the ACC from outside the vehicle.
- Neither control nor a warning are performed in the following situation.
 - Something other than a vehicle approaches, such as a pedestrian.
 - When there is an abnormality in the system (When the ACC detects an abnormality, “ACC SERVICE REQUIRED” is indicated.)
- The ACC makes neither acceleration nor deceleration control and only issues warning in the following situation.
 - The vehicle in front is parked or moving at an extremely slow speed.
- The ACC may not be able to maintain the set speed or the distance to a vehicle in front and may not alert the driver, if the system

CAUTION

cannot detect the vehicle in front properly, in the following situations.

- When a vehicle cuts in front of your vehicle very closely.
- When a vehicle in front is offset to the left or right.
- When a vehicle in front is towing a trailer.
- The vehicle in front is moving at a speed much lower than your vehicle's.
- A motorcycle or a bicycle.
- A freight trailer that is not carrying a container.
- The vehicle has a protruding load from the carrier.
- When the vehicle has a low weight.
- When the vehicle has an extremely high ground clearance.
- When there is repeated steep uphill and downhill driving.
- When driving on an irregular or uneven road surface.
- When being driven in a tunnel.
- When you are carrying extremely heavy loads in the rear seats or luggage area.
- When the Plug-in Hybrid EV System is starting.
- When driving in curved sections of road including their entrance/outlet or running beside a closed lane in a traffic work or similar zone.
- When the cover part in front of the sensor and the sensor become dirty or have snow and ice adhering to it*.

CAUTION

- When water, snow or sand on the road are extorted by the vehicle in front or an oncoming vehicle*.

*: After the ACC control has been cancelled automatically due to detection of a state of decline in performance, the ACC will not operate in the temporary condition and will inform the driver by buzzer and indication. When the ACC is in the state in which it can operate, indication is cancelled. Should indications not be cancelled, then there is a possible abnormality in the system. Please contact a MITSUBISHI MOTORS Authorized Service Point.

7

Cruise control switch

E00634801054

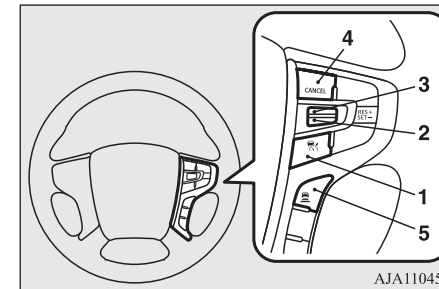

AJA110457

1- “ACC ON/OFF” switch

Used to turn on and off ACC or the cruise control function.

Starting and driving 7-59

OGGE19E1

Adaptive Cruise Control System (ACC)*

2- “SET -” switch

Used to set a desired speed and to reduce the set speed.

3- “RES +” switch

Used to make ACC operate at the originally set speed and also to increase the set speed.

4- “CANCEL” switch

Used to cancel the control function of ACC or the cruise control.

5- ACC distance switch

Used to change the setting of the following distance between your vehicle and a vehicle in front.

7

NOTE

- Operate the individual switches correctly and one after another.
The ACC may be turned off or its control function may be cancelled if two or more switches are pressed concurrently.

Driving aid display

E00634901042

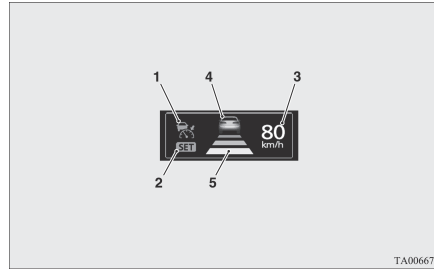

TA0066762

1- ACC indicator:

Indicate that the ACC is ON.

2- Control state indicator:



Indicate that the ACC is active.

3- Set speed:

Indicate the target speed.







4- Vehicles in front symbol:

Comes on when the radar detects a vehicle ahead. Two types of indication; “Stand by” and “Active”

Display	State	
	Stand by	Active
Vehicle in front detected		

5- Following distance setting symbol:

Indicate the set following distance. Two types of indication; “Stand by” and “Active”

Following distance setting symbol	State	
	Stand by	Active
Long		
Middle		
Short		

How to use ACC

E00635001486

To start up (place in 'standby state') the system

With the operation mode set to "ON", press the "ACC ON/OFF" switch shortly to activate the ACC.

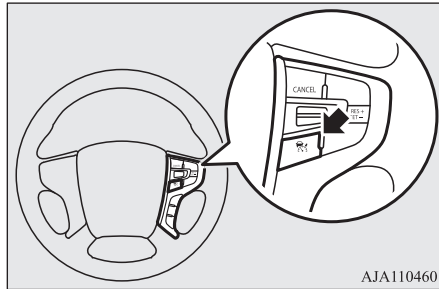

The display on the information screen of the multi-information display will switch to show information on the ACC.

When the ACC is activated, it is placed in the 'standby state' at which any control function is not started.



NOTE

- Even if the ACC is in the activated state when the operation mode is set to "OFF", the system does not automatically become activated when the operation mode is set to "ON" next time.

To activate ACC control

With the ACC turned on (in the 'standby state'), push down the "SET -" switch while driving.

Adaptive Cruise Control System (ACC)*

When your desired speed is reached, release the "SET -" switch; then this speed is set and the ACC initiates the speed control to the set speed.

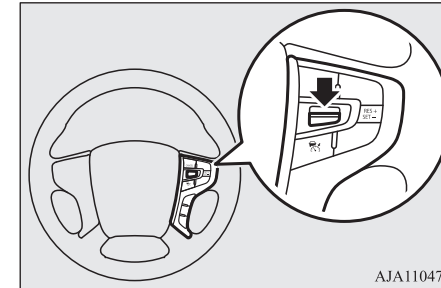

7

The set speed is indicated on the information screen of the multi-information display.

The ACC can be selected between approximately 40 km/h (25 mph) to 180 km/h (112 mph).

You can set and initiate the speed control when driving at approximately 10 km/h (6 mph) to 40 km/h (25 mph) while a vehicle in front is being detected. In this case, the target speed is set to 40 km/h (25 mph).

Setting to any speed outside this range does not cause the ACC to start the control.

Adaptive Cruise Control System (ACC)*

When the ACC is initialized, a buzzer sound is heard and the “SET” indicator lights up on the screen. At the same time, the display showing the following distance setting and the running-ahead vehicle symbol (only when the ACC is detecting a vehicle in front) is switched to the in-control mode display.

7

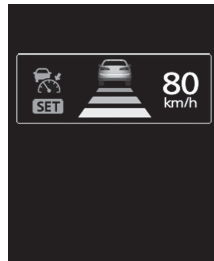

NOTE

- The ACC cannot start the control when any of the following conditions is present. You are alerted to this state by a sounding buzzer.
 - When the vehicle speed is lower than approximately 10 km/h (6 mph) or 180 km/h (112 mph) or higher.
 - When the vehicle is running at a speed between approximately 10 km/h (6 mph) and 40 km/h (25 mph) and the ACC does not detect a vehicle in front.
 - When ASC is in the OFF state.
 - When ABS, ASC or TCL is working.

NOTE

- When the select position is in the “P” (PARK), the “R” (REVERSE) or the “N” (NEUTRAL) position.
- While the brake pedal is being depressed.
- When the parking brake is applied.
- When the system determines that its performance has been degraded due to contaminants adhered to the sensor.
- When there is any abnormality in the system.

To increase the set speed

There are two ways to increase the set speed.

By using the “RES +” switch:

The set speed increases by 1 km/h (1 mph) every time you push up the “RES +” switch while the ACC control is working. If you hold the switch pushed up, the set speed increases in 5 km/h (3 mph) increments.

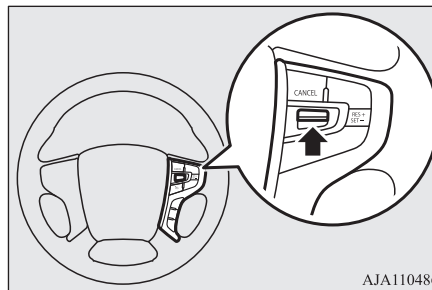

AJA110486

CAUTION

- The setting speed should be set up the suitable speed according to a situation.

NOTE

- There is some time lag between the setting to a new speed and actually accelerating to that speed.
- Speed setting operation is possible even in presence of a vehicle in front. In this case, however, the set speed alone increases without actual acceleration taking place.
- When the switch is held pushed, a buzzer sounds every time the set speed changes.

By using the accelerator pedal:

When the accelerator pedal is depressed while driving with the ACC control working, you can accelerate the vehicle temporarily beyond the presently set speed.

Adaptive Cruise Control System (ACC)*

At the point where the vehicle speed is raised to your desired speed, push down and release the “SET -” switch; the new speed is then set in the system.

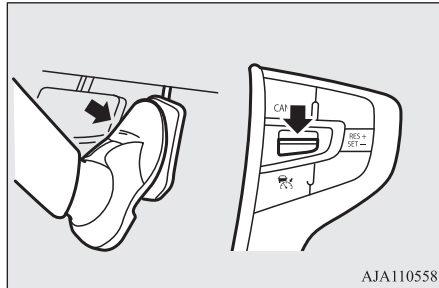

CAUTION

- The ACC braking control and proximity alarm functions will not work while the accelerator pedal is depressed.

NOTE

- The set speed indication on the display turns to “---” when the accelerator pedal is depressed. This indication remains as long as the pedal is in a depressed position.
- The ACC control at the original set speed resumes as soon as you release the accelerator pedal. Under certain conditions, however, the braking control and alarming functions of ACC may not work for a short while after releasing the accelerator pedal.

NOTE

- Set speed adjustment is impossible while the accelerator pedal is in a depressed position.

To decrease the set speed

There are two ways to decrease the set speed.

By using the “SET -” switch:

The set speed decreases by 1 km/h (1 mph) every time you push down the “SET -” switch while the ACC control is working. If you hold the switch pushed down, the set speed decreases in increments of 5 km/h (3 mph).

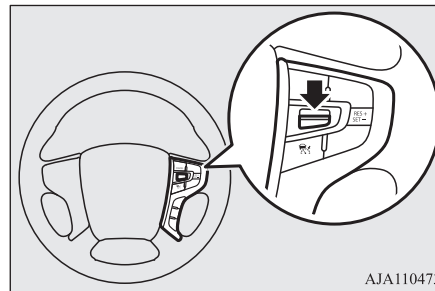

CAUTION

- The setting speed should be set up the suitable speed according to a situation.

NOTE

- There is some time lag between setting to a new speed and actually decelerating to that speed.
- If there is a vehicle in front and your vehicle is following that vehicle at a speed lower than the set speed, the set speed alone decreases with no actual deceleration taking place.
- When the switch is held pushed, a buzzer sounds every time the set speed changes.

By using the brake pedal:

If you depress the brake pedal while the ACC control is working, the control is cancelled, allowing you to decelerate the vehicle.

At the point where the vehicle slows down to your desired speed, push down the “SET -” switch; the new speed is then set in the system.

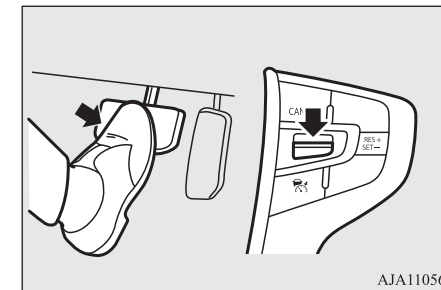

7

Adaptive Cruise Control System (ACC)*

NOTE

- The ACC control is cancelled if you depress the brake pedal and the ACC control does not resume even when you release the pedal.

To temporarily accelerate the vehicle

Simply depress the accelerator pedal to temporarily accelerate the vehicle. Releasing the pedal automatically slows down the vehicle to the set speed and ACC restarts its control.

7

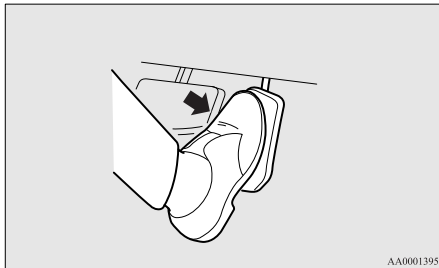

CAUTION

- The ACC braking control and proximity alarm functions will not work while the accelerator pedal is depressed.
- The setting speed should be set up the suitable speed according to a situation.

NOTE

- The set speed indication on the display turns to “---” when the accelerator pedal is depressed. This indication remains as long as the pedal is in a depressed position.
- In certain conditions, the braking control and alarming functions of ACC may not work for a short while after releasing the accelerator pedal.
- Set speed adjustment is impossible while the accelerator pedal is in a depressed position.

To terminate ACC control

To cancel of ACC control

You can cancel the ACC control by using either of the methods below. When the control is cancelled, the system is placed in the ‘standby state’. You can make the system restart the control by using the “SET -” or “RES +” switch if the conditions for activating the control are met.

- Press the “CANCEL” switch.

- Depress the brake pedal.

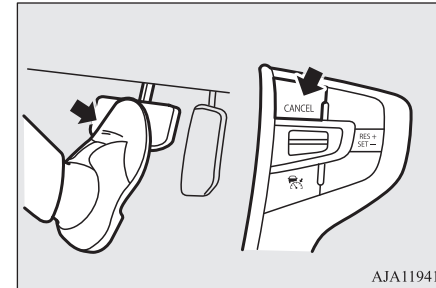

NOTE

- You can also cancel the ACC control by pressing the “ACC ON/OFF” switch. If this switch is pressed, ACC is turned off.

When the system shifts into the ‘standby state’ as a result of cancellation of the ACC control, the “SET” indicator goes out. At the same time, the display of the following distance setting and running-ahead vehicle symbol (only when ACC is detecting a vehicle) is placed in the standby state of display.



The ACC control is automatically cancelled and the ACC is placed in the 'standby' state in any of the situations listed below; you are alerted to this condition by the sound of a buzzer and a message on the display. You can make the system restart the control by using the "SET -" or "RES +" switch if the conditions for resuming the control are reestablished.



- When your vehicle stops as the vehicle in front stops.
- When ASC is turned off.
- When ABS, ASC or TCL is in operation.

- When the select position is in the "P" (PARK), the "R" (REVERSE) or the "N" (NEUTRAL) position.
- When the parking brake is applied.

WARNING

- Although the set speed driving will be deactivated when shifting to the "N" (NEUTRAL) position, never move the selector lever to the "N" (NEUTRAL) position while using regenerative braking as it could cause a serious accident.

When the ACC system determines that its performance has been degraded, a buzzer will sound and a message will be displayed in the multi information display.

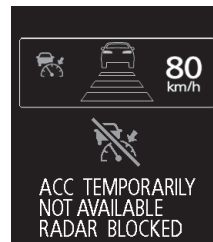

This can occur when:

- Foreign objects, such as dirt, snow or ice, adhere to the surface of the sensor.
- There are adverse weather conditions, such as rain, snow or sand storms, etc.

Adaptive Cruise Control System (ACC)*

- A vehicle in front or an oncoming vehicle is splashing water, snow or dirt.
- Driving on a nonbusy road with a few vehicles and obstacles in front.
- The brake system is overheating due to continuous brake control on long downhill road.

If the display keeps showing the message, there is a possibility that the ACC has a malfunction. Contact a MITSUBISHI MOTORS Authorized Service Point.

7

When the ACC system detects an abnormality in the system, the ACC system will be turned off, a buzzer will sound and a message will be displayed in the multi information display.

If the message remains after the operation mode has been turned to the "OFF" position and then turned back to the "ON" position, contact a MITSUBISHI MOTORS Authorized Service Point.



Starting and driving

7-65

Adaptive Cruise Control System (ACC)*

To turn off ACC

Press the “ACC ON/OFF” switch when ACC is in the ‘ON state’ to turn off ACC.

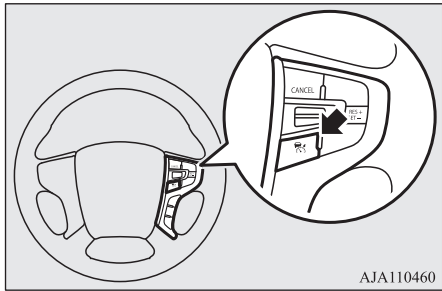

7

NOTE

- Pressing the switch turns off the ACC even if it is engaged.
- The set speed is cancelled when the ACC is turned off or the operation mode is set to “OFF”.
- If the ACC is in the ‘ON state’ when the operation mode is set to “OFF”, the system is set to the ‘OFF state’ when the operation mode is set to “ON” next time.

To resume the control

After cancelling the ACC control (i.e. placing the system in the ‘standby state’) by pressing the “CANCEL” switch or depressing the brake pedal, you can resume the ACC control at the originally set speed if you push up the “RES -” switch.

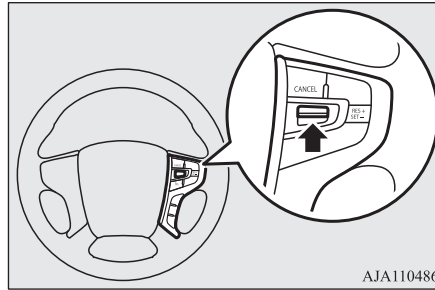

NOTE

- The conditions to be met before the ACC control can be resumed are the same as those for starting the ACC control.

To change the following distance setting

Every time you press the following distance setting switch, the setting changes sequentially through three options “Long”, “Middle” and “Short”, cycling back to “Long” after “Short”. The distance setting is reset when the operation mode is set to “OFF” or when the ACC is set to “OFF,” and is automatically set to “long” when you set the ACC to “ON” next time.

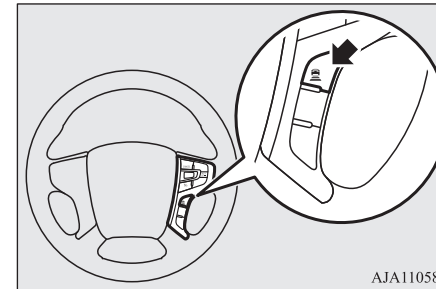

NOTE

- The following distance varies as a function of the speed; the faster the set speed, the longer the following distance.

Forward Collision Mitigation System (FCM)*

Following distance setting: "Long"



Following distance setting: "Middle"



Following distance setting: "Short"



To activate cruise control (automatic speed control)

If you hold the "ACC ON/OFF" switch pressed with the operation mode set to "ON" and the ACC in the 'OFF state', the cruise control is activated. The information screen of the multi-information display then changes to the cruise control screen and a buzzer sounds at the same time.

Cruise control is turned off if you set the operation mode to "OFF".

→ "Cruise control (automatic speed control system)" on page 7-45



CAUTION

- Cruise control (automatic vehicle speed control system) does not alert by proximity alarm and control distance between vehicles to the vehicle in front.

Forward Collision Mitigation System (FCM)*

E00635101243

The Forward Collision Mitigation System (FCM) uses a sensor (A) to determine the distance and relative speed to a vehicle and a pedestrian in front.

When your vehicle is approaching a vehicle or a pedestrian straight-ahead in your path and the FCM judges that there is the risk of a collision, the system gives audible and visual warnings (forward collision warning function), increases the brake fluid pressure (FCM brake prefill function), and also provides braking force assistance when you depress the brake pedal (FCM brake assist function) to avoid frontal collision.

When the risk of collision increases more, the system causes the brakes to work moderately to encourage you to apply brakes. If the system judges that a potential collision is imminent, it initiates emergency braking to mitigate collision-caused damages or to avoid possible collision (FCM braking function).

Stop lamps are illuminated during automatic braking.

If you turn the FCM ON/OFF, the Ultrasonic misacceleration Mitigation System (UMS) also turns ON/OFF at the same time. (Vehicles equipped with the UMS)

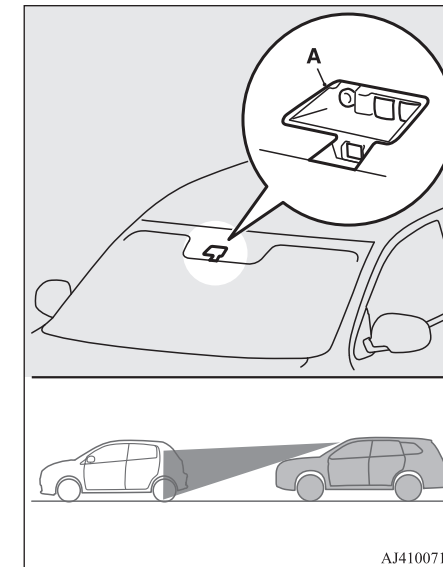

AJ4100714

7

Forward Collision Mitigation System (FCM)*

WARNING

- A driver is responsible for driving safely. The FCM is the system to mitigate collision-caused damages or to avoid collisions as much as possible. The system is not intended to compensate for driver's loss of attention to the front during driving due to distraction or carelessness or supplement a drop in visibility due to the rain and fog. It is never a substitute for your safe and careful driving. Always be ready to apply the brakes manually.
- The FCM works to avoid frontal collisions as much as possible. However, the effect of its operation varies depending on situations and conditions, such as driving conditions, road conditions, and steering, acceleration and braking operations, so that the performance the function can deliver is not always the same. If your vehicle is in danger of collision, take all necessary collision-evading actions, such as depressing the brake pedal strongly regardless of whether the system is activated or not.
- Never attempt to test the operation of the FCM. Doing so could cause an accident, resulting in serious injury or death.

7

Forward collision warning function

E00635401129

If the system judges that there is a risk of your vehicle colliding with a vehicle or a pedestrian in front, this function warns you of the potential hazard with visual and audible alarms.

When this function is triggered, a buzzer sounds and, at the same time, a "BRAKE!" message appears on the information screen of the multi-information display.



The forward collision warning function operates at the following vehicle speed:

- Against a vehicle: Approximately 15 km/h (9 mph) to 140 km/h (87 mph).
- Against a pedestrian: Approximately 7 km/h (5 mph) to 65 km/h (40 mph).

CAUTION

- Under certain conditions, the audible alarm may not work at all or may be scarcely audible. Do not overly rely on the system; if your vehicle is in danger of collision, take all necessary collision-evading actions, such as depressing the brake pedal strongly regardless of whether the system is activated or not.

FCM brake prefill function

E00635201055

If the system judges that there is a risk of your vehicle colliding with a vehicle or a pedestrian in front, this function prefills the brake line with additional brake fluid to make the brakes more responsive to your brake pedal operation.

The FCM brake prefill function operates at the following vehicle speed:

- Against a vehicle: Approximately 5 km/h (3 mph) to 80 km/h (50 mph).
- Against a pedestrian: Approximately 5 km/h (3 mph) to 65 km/h (40 mph).

FCM brake assist function

E00635301072

If the system judges that there is a risk of your vehicle colliding with a vehicle or a pedestrian in front, this function deploys the brake assist sooner than the brake assist operation.

The FCM brake assist function operates at the following vehicle speed:

- Against a vehicle: Approximately 15 km/h (9 mph) to 80 km/h (50 mph).
- Against a pedestrian: Approximately 15 km/h (9 mph) to 65 km/h (40 mph).

CAUTION

- The brake assist function may not be triggered when the brake pedal is operated in certain ways.
Do not overly rely on the system; if your vehicle is in danger of collision, take all necessary collision-evading actions, such as depressing the brake pedal strongly regardless of whether the system is activated or not.

FCM braking function

E00635501380

If the system judges that there is a high risk of your vehicle colliding with a vehicle or a pedestrian in front, the system applies the brakes moderately to encourage you to apply the brakes.

If the system judges that a collision is unavoidable, it initiates emergency braking control to mitigate collision-caused damages or, if the situation permits, to avoid a collision.

When the emergency braking control is triggered, you are warned of the hazard with visual and audible alarms like with the forward collision warning function.

Once the emergency braking has worked, you are alerted to this by a message on the information screen of the multi-information display.

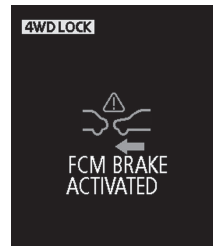

The FCM braking function operates at the following vehicle speed:

- Against a vehicle: Approximately 5 km/h (3 mph) to 80 km/h (50 mph).
- Against a pedestrian: Approximately 5 km/h (3 mph) to 65 km/h (40 mph).

CAUTION

- Do not use the FCM as a normal braking.
- After your vehicle has stopped following the activation of the FCM, automatic braking is released. As the vehicle will then start creeping, be sure to depress the brake pedal to hold the vehicle stationary.

CAUTION

- When applying the brake during the automatic braking condition the pedal will feel firm.
This is not abnormal.
You can apply more pressure to the pedal to assist in braking.
- In the following situations, the system provides neither control nor alarming.
 - When a vehicle or a pedestrian suddenly cuts in front of your vehicle.
 - When the distance from a vehicle or a pedestrian in front is extremely short.
 - To an oncoming vehicle.
 - When the select position is in the “P” (PARK) or the “R” (REVERSE) position.
 - When the FCM has detected a problem in the system.
- If the ASC is deactivated, the FCM braking function will not operate. Refer to “Active Stability Control (ASC)” on page 7-43.
- The FCM may or may not detect a motorcycle, bicycle or wall depending on the situation. The FCM is not designed to detect these objects.
- The forward collision warning function and/or the FCM braking function may not activate in the following situations.
 - When a vehicle suddenly appear just in front of your vehicle.
 - When a vehicle cuts in front of your vehicle very closely.
 - When the vehicle in front is offset to the left or right.

Forward Collision Mitigation System (FCM)*

CAUTION

- When the vehicle in front is towing a trailer.
- A freight trailer that is not carrying a container.
- The vehicle has a protruding load from the carrier.
- The vehicle has a low vehicle height.
- The vehicle has an extremely high ground clearance.
- When a vehicle in front is extremely dirty.
- When a vehicle in front is covered with snow.
- When a vehicle in front has a large glass surface.
- When a vehicle in front does not have reflectors (lamp reflector) or the position of the reflector is low.
- When a vehicle in front is a car carrier or a similar shaped vehicle.
- When there is a different object near the vehicle.
- When driving on a road with many and successive curves, including when passing their entrances and outlets.
- When accelerating and decelerating quickly.
- When the system recognizes driver's steering, accelerating, braking or gear shifting actions as evasive actions to avoid collision.
- When you are driving on a road with steep and alternating up and down slopes.
- When driving on a slippery road covered by rain water, snow, ice etc.

CAUTION

- When a road surface is surging, and there is unevenness.
- When driving in dark areas, such as in a tunnel or at night.
- When your vehicle changed lanes, and your vehicle approached immediately behind the vehicle in front.
- During a certain time after your vehicle turns left or right.
- When you are carrying extremely heavy loads in the rear seats or luggage area.
- After the Plug-in Hybrid EV System has been running for an extended period of time.
- When using a windscreen washer.
- If windscreen wipers are not MITSUBISHI MOTORS GENUINE parts or equivalent.
- When the sensor becomes extremely hot or cold.
- If the auxiliary battery becomes weak or runs down.
- When the sensor is affected by strong light, such as direct sunlight or the headlights of an oncoming vehicle.
- Under adverse weather conditions (rain, snow, sand storms, etc.)
- When the windscreen of the sensor portion is covered with dirt, water droplets, snow and ice, etc.
- When water, snow or sand on the road are extorted by the vehicle in front or an oncoming vehicle.

CAUTION

- The FCM may not detect a pedestrian in certain situations. Some of these include:
 - If the pedestrian is shorter than approximately 1 m or taller than approximately 2 m.
 - If the pedestrian is wearing loose-fitting clothes.
 - If part of a pedestrian's body is hidden, such as when holding an umbrella, large bag, etc.
 - If a pedestrian bends forward, sits or lies on the road.
 - When a pedestrian is pushing/pulling something, such as a stroller, bicycle or wheelchair.
 - When pedestrians gather in a group.
 - When a pedestrian's clothing appears to be nearly the same colour or brightness as its surroundings.
 - When a pedestrian is very close to an object, such as a vehicle.
 - When a pedestrian is in a dark area, such as at night or in a tunnel.
 - When the pedestrian is walking fast or running.
 - When a pedestrian suddenly rushes in front of the vehicle.
 - When the position of a pedestrian is close to the edge of the vehicle.

⚠ CAUTION

- Factors such as the positional relationship between your vehicle and a vehicle in front, driver's own technique of steering the vehicle and irregularly moving traffic due to accidents or vehicle trouble may deter the FCM control and alarm from functioning.
- When the system recognizes driver's steering or accelerating actions as evasive actions to avoid collision, the FCM control and alarm functions may be cancelled.
- The FCM control and alarm functions may be triggered in the following situations.
 - When there is a structure (B) beside the entrance of a curve and intersection.

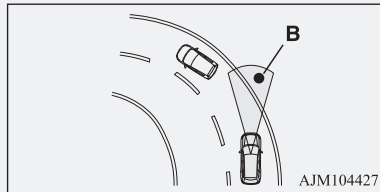

- When running on a narrow iron bridge.
- When passing through a gate with small head or side clearances.
- When there are metallic objects, steps or projections on the road surface.
- When quickly approaching a vehicle in front to overtake it.
- When passing an electronic toll collection gate.
- When running under an overpass, a pedestrian overpass or a small tunnel.
- When running in Multi-storey car park.

⚠ CAUTION

- When the road gradiently and suddenly changes while running.
- When stopping very close to a wall or a vehicle in front.
- When passing close to a vehicle, pedestrian or object.

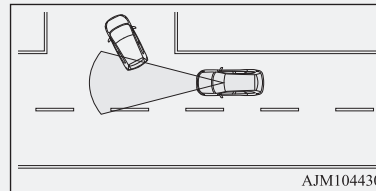

- When driving on the road that the vehicle in front runs in offset position from your vehicle.

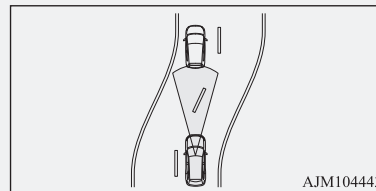

- When passing through an area where objects may contact the vehicle, such as thick grass, tree branches, or a banner.
- When there are patterns on the road that may be mistaken for a vehicle or a pedestrian.
- When a vehicle cuts into your path in the detecting range of the sensor.

⚠ CAUTION

- When an oncoming vehicle is positioned straight ahead of your vehicle on a curved road.
- When passing through a plastic curtain etc.
- When the FCM detects a long object carried on your vehicle, such as skies or a roof carrier.
- When driving through fog, steam, smoke or dust.
- When the windscreen of the sensor portion is covered with dirt, water droplets, snow and ice, etc.
- Turn off the system beforehand when the vehicle is placed in any of the following situations as the system can operate unexpectedly.
 - When using an automatic car wash.
 - When your vehicle's wheels are driven by the Plug-in Hybrid EV System on a lift.
 - When your vehicle is towed or your vehicle tows another vehicle.
 - When your vehicle is carried on a truck.
 - When enjoying sports driving on a circuit.
 - When your vehicle is on a chassis dynamometer or free rollers.
 - When the tyre pressure is not correct.
 - When snow traction device (tyre chains) are attached.
 - If the windscreen on or surrounding the sensor is cracked or scratched.

Forward Collision Mitigation System (FCM)*

NOTE

- A sound will be heard during the activation of automatic braking, this is a function of the brake control and is not abnormal.

FCM and UMS ON/OFF switch

E00635601323

This switch is used to turn on and off the FCM and UMS and also to select your desired collision alarm timing.

7

When the switch is held pressed, the ON/OFF state of the FCM and UMS changes from ON to OFF and vice versa. If you give the switch a short press with the FCM in the ON state, you can change the collision alarm timing.

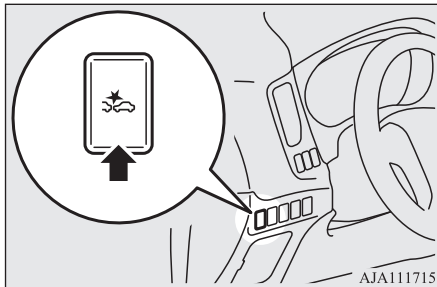

NOTE

- When the FCM and UMS ON/OFF switch is held pressed to change the ON/OFF state of the FCM, the ON/OFF state of the UMS is also changed at the same time.

To turn on/off the system

You can switch the system from OFF to ON or ON to OFF if you hold the FCM and UMS ON/OFF switch pressed when the operation mode is set to “ON”.

Once the system is turned on, the information screen of the multi-information display shows the collision alarm timing currently selected, and the  indicator on the screen goes out.



When you turn off the system, the following message appears on the screen and the  indicator comes on.



Cycling the operation mode to ON will set the FCM back ON.

NOTE

- The  indicator is combined with the “UMS OFF” indicator.

To change alarm timing

Give a short press to the FCM and UMS ON/OFF switch to change the timing at which the frontal collision alarm is triggered. Every time you press the switch, the alarm timing changes between three levels: “FAR” (earlier alarming), “MIDDLE” (normally alarming) or “NEAR” (later alarming).

As you make selection, the selected alarm timing is displayed on the information screen of the multi-information display. Even after turning off the FCM or setting the operation mode to “OFF”, the system retains your last selected alarm timing in memory.

When “FAR” is selected

Forward Collision Mitigation System (FCM)*



When "MIDDLE" is selected

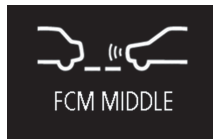

When "NEAR" is selected



CAUTION

- For the FCM brake prefill, the FCM brake assist and the FCM braking functions, the function triggering timing cannot be changed.

When a problem is detected

E00652100023

When the FCM system determines that its performance has been degraded, the FCM will become inoperative.

This can occur when:

- Foreign objects, such as dirt, snow or ice, adhere to the windscreen of the sensor portion.
- There are adverse weather conditions, such as rain, snow, sand storms, etc.
- A vehicle in front or an oncoming vehicle is splashing water, snow or dirt.

The "DRIVER ASSISTANCE CAMERA BLOCKED" message will appear and the  indicator will appear on the information screen of the multi-information display.

When the sensor performance returns, the FCM functions will resume operation.

If the display keeps showing the message, there is a possibility that the sensor has a malfunction. Contact a MITSUBISHI MOTORS Authorized Service Point for inspection of the sensor.

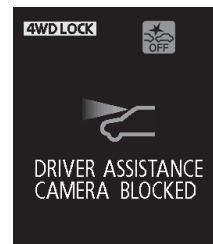

NOTE

- The "DRIVER ASSISTANCE CAMERA BLOCKED" message may temporarily appear on the information screen when the sensor cannot detect a vehicle, a pedestrian or an object within range. This is not a malfunction. When a vehicle or an object comes within range, the FCM function will resume and the message will go off.
- The "DRIVER ASSISTANCE CAMERA BLOCKED" message may appear on the information screen when driving on a non-busy road with a few vehicles and obstacles in front.

7

If the system becomes temporarily unavailable for some reason, the following message may appear.

The  indicator will appear on the information screen of the multi-information display and the FCM will automatically be turned off. If the display keeps showing the message, there is a possibility that the FCM has a malfunction. Contact a MITSUBISHI MOTORS Authorized Service Point for inspection of the system.

Forward Collision Mitigation System (FCM)*





7

If the system becomes temporarily unavailable due to a high or low temperature of the sensor, the following warning message will appear.

The  indicator will appear on the information screen of the multi-information display and the FCM will automatically be turned off. After the temperature of the sensor has been in range, the system will automatically return to operation.

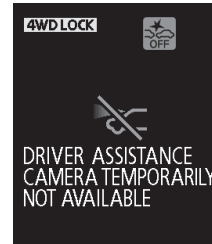
If the display keeps showing the message, there is a possibility that the FCM has a malfunction. Contact a MITSUBISHI MOTORS Authorized Service Point for inspection of the system.



If the FCM detects a malfunction in the system, either one of the following messages will appear, the  indicator will appear on the information screen of the multi-information display and the FCM will automatically be turned off.

If the message remains even after the operation mode is put in OFF and then turned back to ON, please contact a MITSUBISHI MOTORS Authorized Service Point.

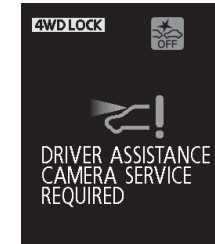

NOTE

- If the sensor or its surrounding area reaches an extremely high temperature when parking the vehicle under a blazing sun, the “FCM SERVICE REQUIRED” message may appear. After the temperature of the sensor or its surrounding area has been in range, if the message remains even after restarting the engine, please contact a MITSUBISHI MOTORS Authorized Service Point.

Handling of the sensor

E00652200125

The sensor (A) is located inside the windscreen as shown in the illustration.

The sensor is shared in the following systems:

- FCM
- Lane Departure Warning (LDW)

● Automatic High-Beam (AHB)

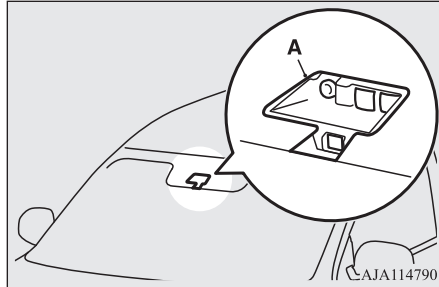

CAUTION

- To maintain proper performance of the FCM, LDW and AHB;
 - Always keep clean the windshield. If the inside of the windshield where the sensor is installed becomes dirty or fogged, contact a MITSUBISHI MOTORS Authorized Service Point.
 - Do not apply an impact or load on the sensor or its surrounding area.

CAUTION

- Do not put anything including a sticker or film to the outer side of the windshield in front of or surrounding area of the sensor. Also, do not put anything including a sticker or film on the both inner and outer side of the windshield under the sensor.

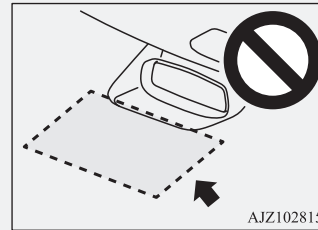

- Do not attempt to detach or disassemble the sensor.
- If the windshield is misted, remove the mist from the windshield by using the demister switch.
- Maintain the wiper blades in good condition. Refer to “Wiper blades” on page 10-06. When replacing the wiper blades, use only MITSUBISHI MOTORS GENUINE parts or equivalent.
- Do not dirty or damage the sensor.
- Do not spray glass cleaner on the sensor. Also, do not spill liquid, such as a beverage, on the sensor.
- Do not install an electronic device, such as an antenna, or a device that emits strong electric waves near the sensor.

CAUTION

- Always use tyres of the same size, same type and same brand and that have no significant wear differences.
- Do not modify the vehicle’s suspensions.
- If the windshield on the sensor or in the surrounding area of the sensor is cracked or scratched, the sensor may not detect an object properly. This could cause a serious accident. Turn off the FCM and have your vehicle inspected as soon as possible at a MITSUBISHI MOTORS Authorized Service Point. If you need to replace the windshield, contact a MITSUBISHI MOTORS Authorized Service Point.
- The sensor emits infrared rays when the operation mode is in ON. Do not look into the sensor by using optical goods such as a magnifying glass. The infrared ray might injure your eyes.

7

Laser radar specifications

Laser classification	
Max average power	45 mW
Pulse duration	33 ns
Wavelength	905 nm
Divergent angle (horizon x vertical)	28° x 12°

Forward Collision Mitigation System (FCM)*

Laser classification label

For Europe

**INVISIBLE LASER RADIATION
DO NOT VIEW DIRECTLY WITH
OPTICAL INSTRUMENTS (MAGNIFIERS)
CLASS 1M LASER PRODUCT**

For Kazakhstan and Belarus

7

ЛАЗЕРНА Я АППАРАТУРА КЛАССА1
ЛАЗЕРНОЕ ИЗЛУЧЕНИЕ
НЕ СМОТРИТЕВ ПУЧОКИ НЕ ПРОВОДИТЕ
НЕПОСРЕДСТВЕННЫХ
НАБЛЮДЕНИЙ С ПОМОЩЬЮ ОПТИЧЕСКИХ
ПРИБОРОВ

For Israel

מוצר לייזר מדרגת הסיכון 1 CLASS 1

Laser warning label

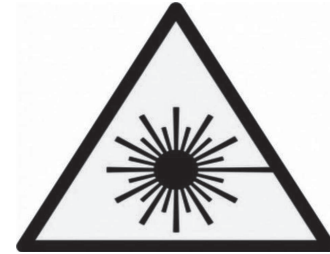

Sınıf II ve üzeri lazerler için uyarı etiketi

Laser explanatory label

Max average power: 45 mW
Pulse duration: 33 ns
Wavelength: 905 nm
IEC 60825-1:2007
Complies with FDA performance standards for laser products
except for deviations pursuant to Laser Notice No. 50, dated
July 26th, 2001

מוצר לייזר Class 1

מוצר הלייזר FRO1000 PF כולל התקן לייזר המשמש לתקשורת. התקנים אלה משמשים לזיהוי עצמאי נגד מכוני לייזר Class 1 בעומס כוונת המנוע. בעשירה הלייזר, הכוונת של התקן לייזר אלה אינם חוות סכנת לייזר והשימוש הנכון אינו על לרובם כוונת. להפעלה נבחרה רכיפה נגיבת חירום, יש להתקן תמיד את כוונת הלייזר והשימוש או כל סוגים אחרים שהמנוע כוללת. כאשר השלל מספק למנוע התקן לייזר יאלו כוונת בעד, על-ידי הכוונת המנוע אשר לכונן כל השמות, התקנים או התקנים אחרים.  הכוונת שימוש בכונתם או המנוע או רכיבם אחרים, שיהיה ללא התחייבות בעת, עלולים לגרום לנזק לרכיבם ולקרינה מסכנת. התקן לייזר Class 1 אלה: המנוע ל- FDA/CDRH 21 CFR, חתום 2001. המנוע ל- EN60825-1:1994+A1+A2



Ultrasonic misacceleration Mitigation System (UMS)*

E00643400280

The Ultrasonic misacceleration Mitigation System (UMS) operates to prevent sudden starts and mitigate collision-caused damages by suppressing the motor output for up to approximately 5 seconds when the system judges that the system is detected the vehicle or obstacles within approximately 4 m in front and behind your vehicle and judges that accelerator pedal was depressed promptly and too strongly such as misoperation of it. This system operates when the vehicle is at stop or is moving forward or backward at less than approximately 10 km/h. When the UMS operates, the warning display appears on the information screen of the multi information display, and the buzzer sounds intermittently.

The UMS ON/OFF is switched in conjunction with the ON/OFF state of the Forward Collision Mitigation (FCM). (Vehicles equipped with FCM)

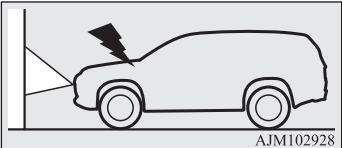
7

Situation	Operation display	Buzzer
<p>When an obstacle is detected in front of your vehicle with the select position in the “D”, if the accelerator pedal is depressed promptly and too strongly, the motor output is suppressed for up to approximately 5 seconds.</p>  <p>AJM102928</p>		<p>Intermittent beeping sound</p>

Ultrasonic misacceleration Mitigation System (UMS)*

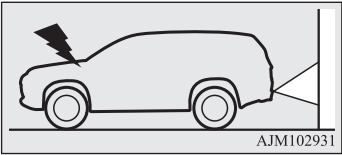
Situation	Operation display	Buzzer
<p>When an obstacle is detected behind your vehicle with the selector lever in the “R” position, if the accelerator pedal is depressed promptly and too strongly, the motor output is suppressed for up to approximately 5 seconds.</p>  <p>AJM102931</p>		

7

⚠ WARNING

- Do not overly rely on the UMS. It is never a substitute for your safe and careful driving. Always be careful to operate the accelerator pedal perceiving the environmental conditions. Misoperation can lead to a serious accident.
- As the UMS is not a function to keep the stop condition of the vehicle, depress the brake pedal according to the environmental condition.
- Depending on the situation, the system does not operate even if the vehicle or the obstacle in front and behind your vehicle and this may cause the vehicle to start suddenly and lead to a serious accident.
- If the vehicle is trapped in the railway crossing because the system is activated as the crossing barrier is misrecognised as an obstacle, escape from the railway crossing without any panic by one of the following methods.
 - Release the foot from the accelerator pedal and lightly depress the pedal again.
 - Turn the system OFF. (Continuously press the FCM and UMS ON/OFF switch for more than 3 seconds.)
 - Continuously depress the accelerator pedal for more than 5 seconds.
 - Repeat to press the accelerator pedal quickly to its full stroke more than three times.
- Do not perform inspection of the system operation on your own. Depending on the situation, this may cause the system to not operate properly and lead to a serious accident.

⚠ CAUTION

- The UMS does not operate in the following conditions:
 - The operation mode is other than ON.
 - The UMS is set to OFF by operating the FCM and UMS ON/OFF switch.
 - The select position is in the “P” or “N” position.
 - The Active stability control (ASC) is set to OFF by operating the “ASC OFF switch” on page 7-44.
- It sometimes happens that a motorcycle, bicycle or pedestrian are detected as obstacles, but these are not the object of the UMS operation.
- The UMS may not operate in the following conditions.
 - The sensors or surroundings have been wiped by hand.
 - The stickers or accessories have been attached to the sensors or surroundings.
 - When driving in the place which the outside temperature changes suddenly (tunnel or garage etc.).
 - Under adverse weather conditions (rain, strong winds, snow, sand storms, etc.).
 - When approaching an obstacle too closely.
 - When a vehicle cuts in front or behind your vehicle very closely.
 - When your vehicle changed the course and approached immediately behind an obstacle.
 - When only a part of the obstacle is within the detection areas of the sensor.
 - When the rain, snow, water or dirt adheres to the sensor.
 - When the sensor is extremely hot or cold (while the vehicle is parked for a long period of time under a blazing sun or in cold weather).
 - Immediately after Plug-in Hybrid EV System starting.
 - When driving on a road with many and successive curves, including when passing their entrances and outlets.
 - When you are driving on a road with steep and alternating up and down slopes.
 - When a road surface is surging, and there is unevenness.
 - When the system judges driver’s steering or gear shifting actions as evasive actions to avoid collision.
 - For a short period after the system judges the repeated depression of the accelerator pedal at a few seconds interval as a release operation.
 - When the vehicle body is extremely inclined by carrying heavy loads or improper adjustment of the tyre pressure.
 - When the driving is unstable due to an accident or trouble.
 - The system receives ultrasonic noise from other sources (the horns of other vehicles, motorcycle engines, brakes, radios, pouring rain, splashing water, snow traction device (tyre chains), etc.).
 - Obstacle is not vertical to the ground, the obstacle is not at right angles to vehicle traveling direction, or when there is uneven walls and wavy walls.

Ultrasonic misacceleration Mitigation System (UMS)*

CAUTION

- The UMS operation may be cancelled when the system judges the handle operation as evasive actions or when the obstacle moves out of the detectable area of the sensor.
- The UMS may be triggered in the following situations.
 - When water, snow or sand on the road are extorted by the vehicle in front or an oncoming vehicle.
 - When there are objects, steps or projections on the road surface.
 - When the parking gate or railway barrier is raised imperfectly.
 - When running the road, the gradient changes suddenly.
 - When passing through the mass of the steam, fog or smoke.
 - When driving in close to the vehicle ahead, and when stopping in close to the forward/ backward vehicle or a wall.
 - When there is an obstacle in a curb or an intersection.
 - When your vehicle joins the main line from parallel parking.
 - When there is a ultrasonic near your vehicle by horn of other vehicle, engine sound of a motorcycle, air brake noise of a large vehicle, a vehicle detector and sonar of a vehicle etc.
 - When an electrical equipment on the market (radio antenna etc.) is installed near the sensor.
 - When driving on a gravel road.
 - When the surrounding area is overgrown with weeds.
- Turn off the system by pressing the FCM and UMS ON/OFF switch beforehand when the vehicle is placed in any of the following situations as the system can operate unexpectedly.
 - When getting out from a road groove or a mud.
 - When using an automatic car wash.
 - When an elevator for vehicle or a mechanical parking is used.
 - When your vehicle's wheels are driven by the motor on a lift.
 - When your vehicle is towed or your vehicle tows another vehicle.
 - When your vehicle is carried on a truck.
 - When driving on a circuit.
 - When your vehicle is on a chassis dynamometer or free rollers.
 - When the tyre pressure is not correct.
 - When snow traction device (tyre chains) are attached.

7

⚠ CAUTION

- Improperly handling the system components may result in such problems as degraded sensor performance and ultimately in an accident. Be sure to take the following precautions to keep the system in good operating conditions.
 - Avoid application of strong shock loads to the sensor.
 - The sensor should be kept clean.
 - Do not cover the sensor with a sticker or anything.
 - Do not modify the suspension of your vehicle.
- If the bumper has been exposed to an impact, the sensors may fail and prevent the system from functioning properly. Have the vehicle inspected at a MITSUBISHI MOTORS Authorized Service Point.

Obstacle detection areas

E00643500047

The detection areas of the sensors are limited. Moreover, the sensors are unable to detect low or thin objects or objects near the rear bumper. Make sure to check the surroundings as you operate the vehicle in a safe manner.

Sensor locations

E00643600165

There are the sensors (A) on each of four places of the front bumper and the rear bumper.

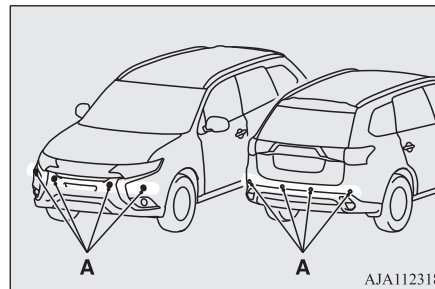

⚠ CAUTION

- The UMS may not operate because the sensor cannot detect the vehicle in front or obstacle as follows.

OGGE19E1

⚠ CAUTION

- Vehicle towing a trailer etc.
- A freight trailer that is not carrying a container.
- Vehicle that has a protruding load from the carrier.
- An obstacle with a low height.
- Vehicle that has an extremely high ground clearance.
- Vehicle that is extremely stained.
- Vehicle or obstacle that is covered with snow.
- The vehicle is the specific shape such as the carrier car.
- Obstacles that have the shape of the pole such as the road marker or the streetlight.
- Obstacles that exist in the high position from the ground.
- Obstacles that are soft and absorb ultrasonic easily, such as spongy material or snow.

Blind Spot Warning (BSW) (with Lane Change Assist)*

CAUTION

- Obstacles that are shaped with a sharp angle.
- A fence with large mesh.
- Moving object.
- When there is a loud noise or an ultrasonic near your vehicle by horn of other vehicle, engine sound of a motorcycle, air brake noise of a large vehicle, a vehicle detector and sonar of a vehicle etc.
- When an electrical equipment on the market (radio antenna etc.) is installed near the sensor.
- When there is a obstacle that is not recognized between your vehicle and the obstacle that can be recognized.

7

NOTE

- The sensors do not detect objects located in the area directly below or near the bumper. If the height of an object is lower than the mounted position of the sensors, the sensors may not continue detecting it even if they detected it initially.

To turn on/off the UMS

E00643800095

The UMS is automatically turned ON by setting the operation mode to ON. In addition, the UMS ON/OFF is switched in conjunction with the ON/OFF state of the FCM. Refer to “FCM and UMS ON/OFF switch” on page 7-72.

7-82 Starting and driving

Warning display

E00643900025

When the sensor is temporarily not available

E00647600033

Example: When the front and/or rear sensors are temporarily not available



When the warning display appears, the sensors are temporarily not available for some reason such as the environmental condition or increase of the sensor temperature. When the warning display appears continuously, contact a MITSUBISHI MOTORS Authorized Service Point.

When there is a malfunction in the sensor or the system

E00644000108

Example: When there is a malfunction in both sensors.



OGGE19E1

When the warning display appears, the UMS does not operate normally because there are some malfunctions in the system. Have the vehicle inspected at a MITSUBISHI MOTORS Authorized Service Point as soon as possible.

Blind Spot Warning (BSW) (with Lane Change Assist)*

E00644300156

The Blind Spot Warning (BSW) is a driving aid system that alerts the driver when another vehicle, which may not be visible through the outside rear-view mirror, is travelling in the next lane behind your vehicle.

When a vehicle in the next lane is travelling at the same speed or faster in the detection areas, the Blind Spot Warning lamp in the corresponding outside rear-view mirror will illuminate. If the turn-signal lever is operated to the side where the Blind Spot Warning lamp is illuminated, the Blind Spot Warning lamp will blink and the system will beep three times to alert the driver.

Blind Spot Warning (BSW) (with Lane Change Assist)*

Depending on the relative speed between your vehicle and a vehicle in the next lane, the Blind Spot Warning system will detect up to approximately 70 m from your vehicle. (Lane Change Assist)

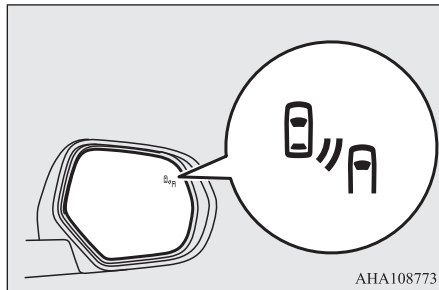

Detection areas

E00644400388

The BSW uses two sensors (A) located inside the rear bumper.

The detection areas are shown as illustrated.

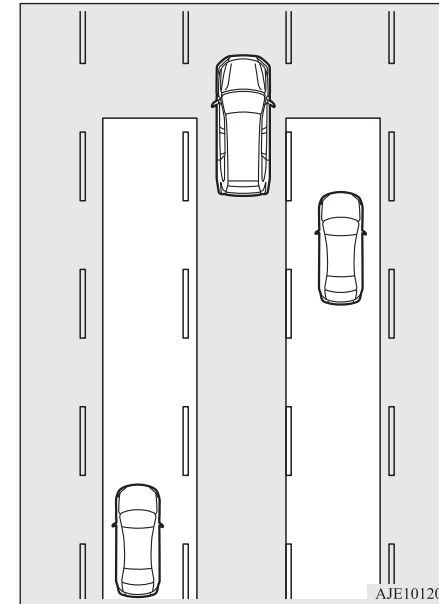
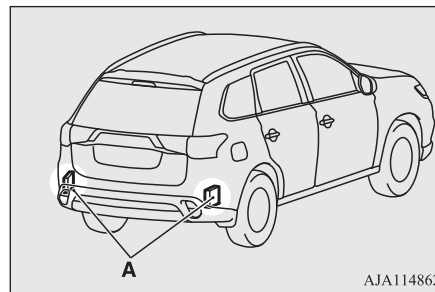

⚠ WARNING

- Before using the BSW, read this entire section to fully understand the limitations of this system. Failure to follow instructions could result in an accident.
- Never rely solely on the BSW system when changing lanes. The BSW is an aid only. It is not a substitute for your safe and careful driving. Always check visually behind and all around your vehicle for other vehicles. The performance of the BSW may vary depending on driving, traffic and/or road conditions.

⚠ WARNING

- In certain situations, the BSW may not detect a vehicle in the detection areas or the detection may be delayed. Some of these include:
 - When a small motorcycle or a bicycle is behind your vehicle.

7

Blind Spot Warning (BSW) (with Lane Change Assist)*

⚠ WARNING

- When a vehicle is travelling alongside of your vehicle at nearly the same speed for prolonged periods of time.
- When the heights of the next lane and your lane are different.
- Immediately after the BSW has been turned on.
- Immediately after the power switch is turned on.
- Under adverse weather conditions, such as rain, snow, strong winds or sand storms.
- When your vehicle comes too close to another vehicle.
- While multiple vehicles are overtaking your vehicle.
- When driving near a pot hole and tramline.
- When a surrounding vehicle or an on-coming vehicle is splashing water, snow or dirt.
- When driving on a curve including the beginning and the end of the curve.
- When driving on a road with alternating up and down steep slopes.
- When driving on a bumpy or rough road.
- When the rear of your vehicle is weighed down or your vehicle is leaning to the right or left due to the weight of passengers and luggage or the improper adjustment of tyre pressure.
- When the bumper surface around the sensor is covered with dirt, snow and ice, etc.

⚠ WARNING

- When the sensor is extremely hot or cold (while the vehicle is parked for a long period of time under a blazing sun or in cold weather).
- When a bicycle carrier or accessory is installed to the rear of the vehicle.

⚠ CAUTION

- To maintain proper performance of the BSW, follow the instructions below.
 - Always keep the bumper surface around the sensor clean.
 - Avoid impacting the sensor or its surrounding area.
 - Do not put a sticker on the sensor or its surrounding bumper surface.
 - Do not paint the sensor or its surrounding bumper surface.
 - Do not modify the sensor or its surrounding area.
- If the bumper has experienced an impact, the sensor may have been damaged and the BSW may not function properly. Have the vehicle inspected at a MITSUBISHI MOTORS Authorized Service Point.

To operate

E00652300298

When the BSW switch is pressed while the operation mode is ON, the BSW indication lamp in the instrument cluster comes on and the BSW goes into the stand by state. When the BSW switch is pressed again, the BSW indication lamp in the instrument cluster goes off and the BSW turns off.

Indication lamp

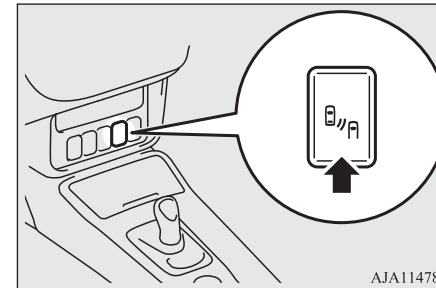

If you turn the BSW ON/OFF, the Rear Cross Traffic Alert (RCTA) also turns ON/OFF at the same time.

Blind Spot Warning (BSW) (with Lane Change Assist)*

NOTE

- When the operation mode is set to OFF, the selected condition just before setting to OFF is retained.
- The BSW operates when all of the following conditions are met.
 - The operation mode is put in ON.
 - The select position is in a position other than “P” (PARK) and “R” (REVERSE).
 - The speed of your vehicle is approximately 10 km/h (6 mph) or higher.

When the sensor detects an approaching vehicle

When the BSW indication lamp in the instrument cluster is on, if a vehicle is approaching your vehicle in the detection area, the Blind Spot Warning lamp in the outside rear-view mirror illuminates.

If the turn-signal lever is operated to the side where the Blind Spot Warning lamp is illuminated, the Blind Spot Warning lamp will blink and the system will beep three times to alert the driver.

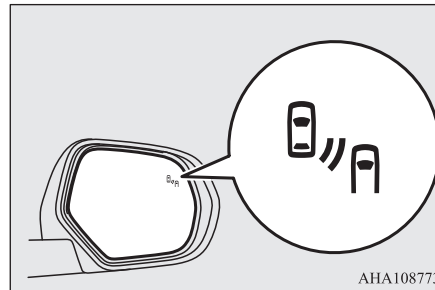

NOTE

- The Blind Spot Warning lamp in the outside rear-view mirror may come on or blink in the following conditions.
 - When driving very near the guardrail or a concrete wall.
 - When driving on the entrance and outlet of a tunnel or very near to the wall or near the evacuation area inside a tunnel.
 - When turning at an intersection in a town area.
 - Under adverse weather conditions (rain, snow, sand storms etc.).

NOTE

- When you drive your vehicle with blowing up the water, snow or sand etc. on the road.
- When driving near a pothole and tramline.
- Set the BSW to OFF when towing.
- The Blind Spot Warning lamp in the outside rear-view mirror may not be visible due to strong direct sunlight or the glare from the headlamps of vehicles behind you during night driving.

System problem warning

E00692500029

If a problem occurs with the system, a visual warning specific to the type of the problem is given together with an audible alarm. The warnings are combined with the Rear Cross Traffic Alert (RCTA) system.

When there is a malfunction in the system or the sensor

E00692600020



7

Rear Cross Traffic Alert (RCTA)*

When the warning display appears, the BSW does not operate normally because there are some malfunctions in the system or the sensor. Have the vehicle inspected at a MITSUBISHI MOTORS Authorized Service Point as soon as possible.

NOTE

- When the warning display appears, the BSW will be deactivated.

7

When the sensor is temporarily not available

E00692700021



When the warning display appears, the sensor is temporarily not available for some reason such as the environmental condition or increase of the sensor temperature. When the warning display does not disappear after waiting for a while, contact a MITSUBISHI MOTORS Authorized Service Point.

When there are foreign objects on the sensor

E00692800165



When the warning display appears, the sensor cannot detect a vehicle travelling side by side or an approaching vehicle, because foreign objects, such as dirt, snow or ice, adhere to the bumper surface around the sensor. Remove dirt, freezing or foreign material on the bumper surface around the sensor. When the warning display does not disappear after having cleaned the sensor, contact a MITSUBISHI MOTORS Authorized Service Point.

Rear Cross Traffic Alert (RCTA)*

E00652400257

The Rear Cross Traffic Alert (RCTA) is an aid system for backing up. When the RCTA system detects vehicles approaching from sides while your vehicle is reversing, the Blind Spot Warning lamps in the outside rear-view mirrors on both sides will blink and a buzzer will sound to alert the driver. A warning message will also appear on the information screen of the multi-information display.

Rear Cross Traffic Alert (RCTA)*

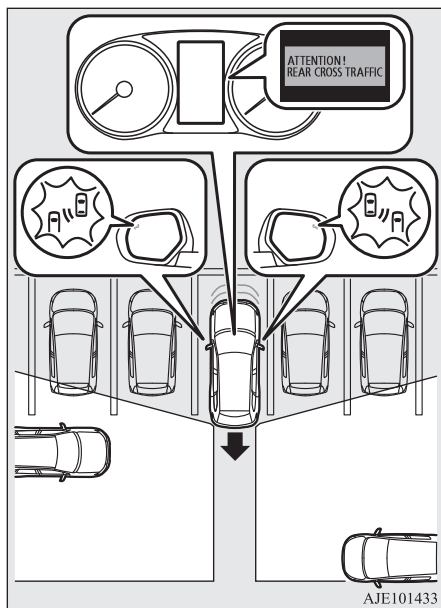

WARNING

- Before using the RCTA, read this entire section to fully understand the limitations of this system. Failure to follow instructions could result in an accident.

WARNING

- Never rely solely on the RCTA when backing up. The RCTA is an aid system. It is not a substitute for your safe and careful driving. Always check visually behind and all around your vehicle for other vehicles, persons, animals or obstructions. The performance of the RCTA may vary depending on driving, traffic and/or surrounding conditions.

NOTE

- The Blind Spot Warning lamps in the outside rear-view mirrors on both sides will blink, even when only one vehicle is approaching from one side.

Detection areas

The detection area is shown as illustrated.

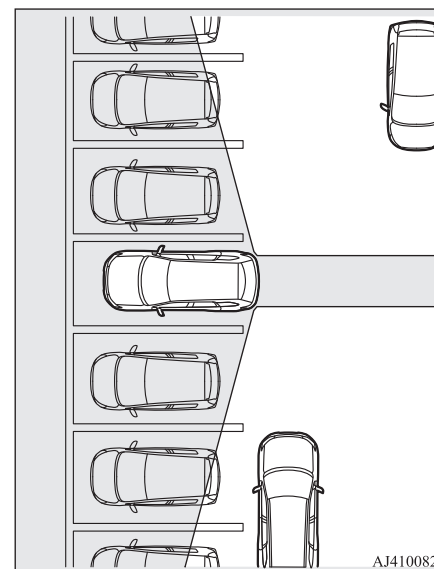

7

CAUTION

- In certain situations, the RCTA may not detect a vehicle in the detection areas. Some of these situations include:

Lane Departure Warning (LDW)*

CAUTION

- When the reversing speed of your vehicle is approximately 18 km/h (11 mph) or higher.
- When the speed of an approaching vehicle is approximately 7 km/h (5 mph) or less.
- If the sensor detection area is blocked by a nearby object, such as a wall or parked vehicle.
- When a vehicle is approaching from straight behind your vehicle.
- When your vehicle is exiting from an angled parking spot.

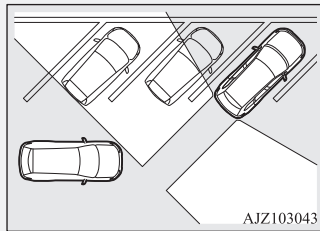

- Immediately after the RCTA has been turned on.
- Immediately after the operation mode of the power switch has been put in ON.
- When the bumper surface around the sensor is covered with dirt, snow and ice, etc.
- When the sensor becomes extremely hot or cold, such as after the vehicle has been parked for a prolonged time under the blazing sun or in cold weather.

CAUTION

- If the bumper has experienced an impact, the sensor may have been damaged and the RCTA may not function properly. Have the vehicle inspected at a MITSUBISHI MOTORS Authorized Service Point.

To operate

1. Press the BSW switch while the operation mode is put in ON.
(Refer to “Blind Spot Warning (BSW): To operate” on page 7-84.)
2. When the select position is put in the “R” (REVERSE) position, the RCTA will operate.

NOTE

- Set the RCTA to OFF when towing.
- The Blind Spot Warning lamp in the outside rear-view mirror may not be visible due to strong direct sunlight or the glare from the headlamps of vehicles behind you during night driving.

When a problem is detected in the system

If the system detects a problem, a warning is displayed on the information screen in the multi-information display.

Refer to “Blind Spot Warning (BSW): System problem warning” on page 7-85.

Lane Departure Warning (LDW)*

E00635701281

By recognizing through a sensor (A) the lane in which your vehicle is running, the LDW gives you a warning when your vehicle is likely to drift from its lane with an audible alarm and a visual alarm displayed on the information screen of the multi-information display.

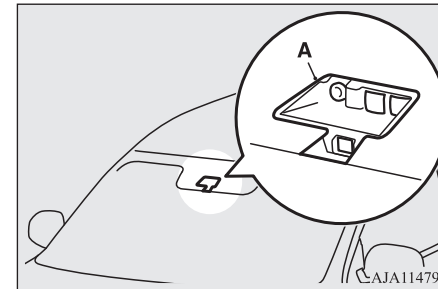

Lane Departure Warning (LDW)*

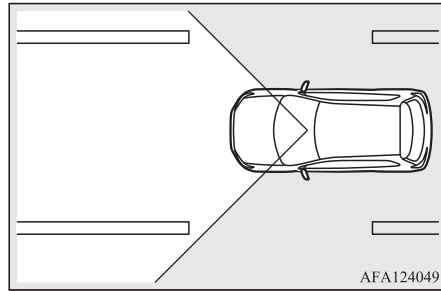

How to operate the LDW

E00635801325

The indication on the information screen of the multi-information display changes as follows depending on the state of the system.

To turn on/off the LDW

NOTE

- The LDW is turned on when the vehicle is shipped from the factory.
- The currently selected LDW setting (on or off) is stored even when the operation mode of the power switch is put in OFF.

To turn on the LDW, press the LDW switch. The “LDW” indicator will appear on the information screen of the multi information display and the system is placed in the ‘ON state’.

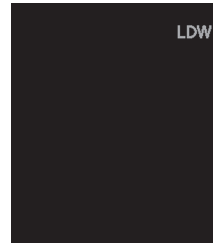

To turn off the LDW, press the LDW switch. The “LDW” indicator on the information screen of the multi information display will then go out and the system is placed in the ‘OFF state’.

To return the LDW to the ‘ON state’, press the LDW switch again.

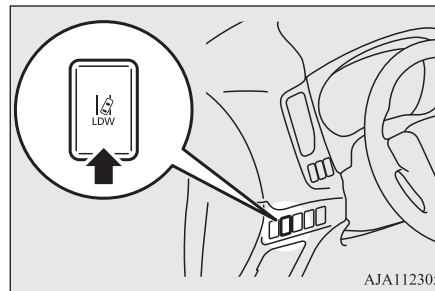

Standby state

In the standby mode, the system is capable of recognizing the lane in which your vehicle is positioned and issuing audible warning when your vehicle goes out of the lane.

The system automatically shifts from the ‘ON state’ to the ‘standby state’ if all of the following conditions are simultaneously met. The “LDW” indicator in the information display changes to  indicator (green).

- The vehicle speed is approximately 65 km/h (40 mph) or higher.
- The turn-signal lever is not operated.
- The hazard lamp is not activated.
- Environmental conditions are adequate for the system to recognize the lane markings on both sides.
- The system has been placed in the ‘ON state’.



7

Lane Departure Warning (LDW)*

NOTE

- The system stays in the “ON” state for approximately 7 seconds after the hazard lamp has stopped flashing or the turn-signal lever has returned to the home position.

Lane departure warning

A buzzer sounds intermittently and indication of “LANE DEPARTURE” appears in the information display,  indicator flashing in amber when your vehicle is about to leave or has left the lane in the standby mode.

7



NOTE

- If the warning continues for approximately 3 seconds or more, the system switches to the standby mode before the warning stops.

NOTE

- If the lane markers are only on one side of the road, the LDW will operate only for the appropriate side where the lane marker is drawn.

System problem warning

If a problem occurs with the system, a visual warning specific to the type of the problem is given together with an audible alarm.

Too hot or cold sensor

The alarm shown below is displayed if the system becomes temporarily unavailable due to a too high or low temperature of the sensor.

If the temperature of the sensor reaches the predetermined value, the system automatically recovers the normal state.

If the alarm continues showing, there is a possibility that the LDW has a malfunction. Contact a MITSUBISHI MOTORS Authorized Service Point for inspection of the system.

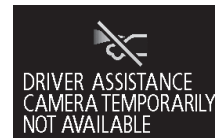

Windscreen is dirty

The alarm shown below is displayed if the system becomes temporarily unavailable due to dirt on the windscreen at the sensor portion.

After having cleaned the windscreen, the system will automatically return to operation.

If the alarm continues showing, there is a possibility that the sensor has a malfunction. Contact a MITSUBISHI MOTORS Authorized Service Point for inspection of the sensor.



LDW deactivation due to fault

The alarm shown below is displayed if the LDW goes into a non-initialized state due to a fault.

If this happens, please contact a MITSUBISHI MOTORS Authorized Service Point for inspection of the system.

Lane Departure Warning (LDW)*

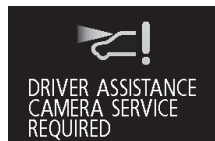

NOTE

- If the sensor or its surrounding area reaches an extremely high temperature when parking the vehicle under a blazing sun, the "LDW SERVICE REQUIRED" message may appear. If the message remains even after the temperature of the sensor or its surrounding area has been in range, please contact a MITSUBISHI MOTORS Authorized Service Point.

CAUTION

- LDW has its performance limitations. Do not over-rely on the system.

CAUTION

- LDW is not designed to lessen risks associated with not looking ahead carefully (attention drawn to something on the side, absent-mindedness, etc.) or poor visibility caused by bad weather etc. Keep steering your vehicle correctly and drive safely.
- The system may not operate correctly in the following conditions. If required, set the LDW switch to "OFF."
 - When driving on a road whose lane markings (white or yellow) are worn out or smeared with dirt to an extent not recognizable by the system.
 - When lane markings are vague, typically during a drive in the rain, snow, fog or dark area, or when running against the sun.
 - When the vehicle is moving in a place where lane markings are interrupted, such as a toll booth entrance and motorway junction.
 - When running on a road portion with incompletely removed old lane markings, shadows, lingering snow, truck-like puddles mistakable for lane markings (especially after the rain when road surface is reflecting light) or similar confusing factors.
 - When running in a lane other than the cruising lane and passing lane.
 - When running beside a closed lane section or in a provisional lane in a traffic work zone.

CAUTION

- When running in an extremely narrow lane.
- When the following distance between your vehicle and a vehicle in front becomes extremely reduced (especially when a marking is hidden by a vehicle in front this is running too close to the marking).
- When entering a junction or other point of road where lanes are laid out complicatedly.
- When passing a road section where the number of lanes increases/decreases or multiple lanes are crossing each other.
- When the lane is marked by double or otherwise special lines.
- When driving on a winding or rough road.
- When driving on a slippery road covered by rain water, snow, ice, etc.
- When passing through a place where the brightness suddenly changes, like the inlet or outlet of a tunnel.
- When turning steep curves.
- When the road surface is reflecting the light shining from the direction opposite to the running direction.
- Vehicle largely lurches when it is running over steps or other irregularities of the road surface.
- When the headlamp illumination is inadequate because of contaminated or deteriorated lenses or improperly aimed headlamps.

7

Tyre pressure monitoring system (TPMS)

CAUTION

- When the vehicle is leaning much to one side due to heavy luggage on it or improperly adjusted tyre pressures.
- When oncoming vehicles' headlamps shine the sensor.
- When the vehicle is equipped with non-standard tyres (including excessively worn tyres), is using a snow traction device (tyre chains), or has non-specified components such as a modified suspension.
- When the windscreen is covered with water droplets, snow, dust, etc.
- Follow the instructions given below to keep your LDW in good operating conditions.
 - Always keep the windscreen clean.
 - Avoid applying a strong shock or pressure to the sensor. Do not attempt to detach or disassemble it.
 - Do not put anything like a sticker on the area in front of the sensor lens of the windscreen.
 - Use only MITSUBISHI MOTORS GENUINE Parts when replacing the windscreen wipers.

7

Tyre pressure monitoring system (TPMS)

E00637100282

The tyre pressure monitoring system (TPMS) uses tyre inflation pressure sensors (A) on the wheels to monitor the tyre inflation pressures. The system only indicates when a tyre is significantly under-inflated.

The base tyre pressure can be set at desired value by the driver with the reset function execution. (The low pressure warning threshold is set based on the reset.)

The tyre inflation pressure sensor IDs for two sets of tyres can be registered by a MITSUBISHI MOTORS Authorized Service Point, and the valid ID set can be switched by the Multi-information display switch (It's beneficial in case of seasonal tyre change between summer tyre and winter tyre.)

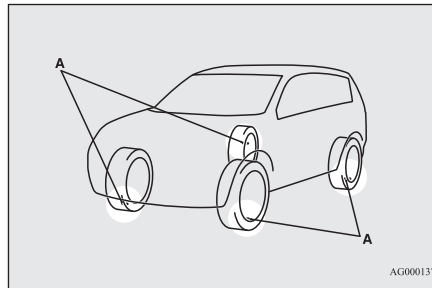

AG0001377

NOTE

- The tyre pressure monitoring system (TPMS) is not a substitute for regularly checking tyre inflation pressures. Be sure to check the tyre inflation pressures as described in "Tyres" on page 11-10.
- The tyre inflation pressure sensor (B) is installed in the illustrated location.
 - On vehicles with the type 1 sensor which has the metallic air valve (C), replace grommet and washer (D) with the new ones when the tyre is replaced.
 - On vehicles with the type 2 sensor which has the rubber air valve (E), replace the rubber air valve (E) with the new one when the tyre is replaced.

For details, please contact your MITSUBISHI MOTORS Authorized Service Point.

Tyre pressure monitoring system (TPMS)

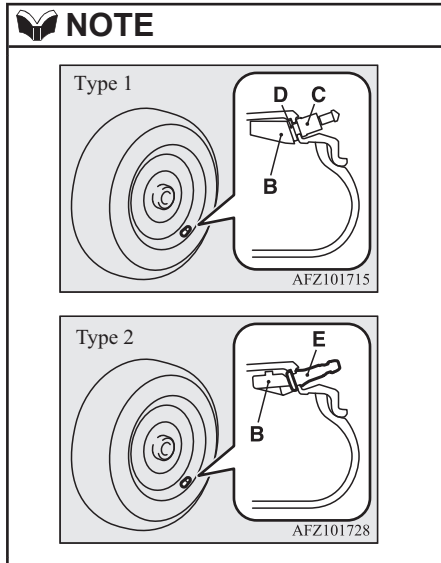

Tyre pressure monitoring system warning lamp/display

E00637200078



When the operation mode is put in ON, the tyre pressure monitoring system warning lamp normally illuminates and goes off a few seconds later.

If one or more of the vehicle tyres is significantly under-inflated, the warning lamp will remain illuminated while the operation mode is in ON.

Refer to “If the warning lamp/display illuminates while driving” on page 7-94 and take the necessary measures.

NOTE

- In addition, the warning display will be displayed on the information screen in the multi-information display.



CAUTION

- If the warning lamp does not illuminate when the operation mode is put in ON, it means that the tyre pressure monitoring system (TPMS) is not working properly. Have the system inspected by a MITSUBISHI MOTORS Authorized Service Point. In such situations, a malfunctioning of the system may be preventing the monitoring of the tyre pressure. Avoid sudden braking, sharp turning and high-speed driving.

CAUTION

- If a malfunction is detected in the tyre pressure monitoring system (TPMS), the warning lamp will blink for approximately 1 minute and then remain continuously illuminated. The warning lamp will issue further warnings each time the Plug-in Hybrid EV System is restarted as long as the malfunction exists.

Check to see whether the warning lamp goes off after few minutes driving.

If it then goes off during driving, there is no problem.

However, if the warning lamp does not go off, or if it blinks again when the Plug-in Hybrid EV System is restarted, have the vehicle inspected by a MITSUBISHI MOTORS Authorized Service Point.

In such situations, a malfunctioning of the system may be preventing the monitoring of the tyre pressure. For safety reasons, when the warning lamp appears while driving, avoid sudden braking, sharp turning and high-speed driving.

7

Tyre pressure monitoring system (TPMS)

NOTE

- In addition, the warning display will be displayed on the information screen in the multi-information display.



7

Each tyre, including the spare (if so equipped), should be checked monthly when cold and inflated to the inflation pressure recommended by the vehicle manufacturer on the tyre inflation pressure label. (If your vehicle has tyres of a different size than the size indicated on the tyre inflation pressure label, you should determine the proper tyre inflation pressure for those tyres.)

As an added safety feature, your vehicle has been equipped with the tyre pressure monitoring system (TPMS) that illuminates a low tyre pressure telltale when one or more of your tyres is significantly under-inflated.

Accordingly, when the low tyre pressure telltale illuminates, you should stop and check your tyres as soon as possible, and inflate them to the proper pressure. Driving on a significantly under-inflated tyre causes the tyre to overheat and can lead to tyre failure.

Under-inflation also reduces fuel efficiency and tyre tread life, and may affect the vehicle's handling and stopping ability.

Please note that the tyre pressure monitoring system (TPMS) is not a substitute for proper tyre maintenance, and it is the driver's responsibility to maintain correct tyre pressure, even if under-inflation has not reached the level to trigger illumination of the tyre pressure monitoring system (TPMS) low tyre pressure telltale.

Your vehicle has also been equipped with a warning lamp to indicate when the system is not operating properly.

The warning lamp is combined with the low tyre pressure telltale.

When the system detects a malfunction, the telltale will flash for approximately one minute and then remain continuously illuminated. This sequence will continue upon subsequent vehicle start-ups as long as the malfunction exists.

When the warning lamp is illuminated, the system may not be able to detect or signal low tyre pressure as intended.

The tyre pressure monitoring system (TPMS) malfunctions may occur for a variety of reasons, including the installation of replacement or alternate tyres or wheels on the vehicle that prevent the tyre pressure monitoring system (TPMS) from functioning properly. Always check the tyre pressure monitoring system (TPMS) malfunction telltale after replacing one or more tyres or wheels on your vehicle to ensure that the replacement or alternate tyres and wheels allow the tyre pressure monitoring system (TPMS) to continue to function properly.

If the warning lamp/display illuminates while driving

E00637300079

1. If the warning lamp illuminates, avoid hard braking, sharp steering manoeuvres and high speeds. You should stop and adjust the tyres to the proper inflation pressure as soon as possible. Adjust the spare tyre at the same time. Refer to "Tyres" on page 11-10.

NOTE

- In addition, the warning display will be displayed on the information screen in the multi-information display.

Tyre pressure monitoring system (TPMS)

NOTE

- When inspecting or adjusting the tyre pressure, do not apply excessive force to the valve stem to avoid breakage.
- After inspecting or adjusting the tyre pressure, always reinstall the valve cap on the valve stem.
Without the valve cap, dirt or moisture could get into the valve, resulting in damage to the tyre inflation pressure sensor.
- Do not use metal valve caps, which may cause a metal reaction, resulting in corrosion and damage of the tyre inflation pressure sensors.
- Once adjustments have been made, the warning lamp will go off after a few minutes of driving.

2. If the warning lamp remains illuminated after you have been driving for about 10 minutes after you adjust the tyre inflation pressure, one or more of the tyres may have a puncture. Inspect the tyre and if it has a puncture, have it repaired by a MITSUBISHI MOTORS Authorized Service Point as soon as possible.

WARNING

- **If the warning lamp/display illuminates while you are driving, avoid hard braking, sharp steering manoeuvres and high speeds.
Driving with an under-inflated tyre adversely affects vehicle performance and can result in an accident.**

CAUTION

- The warning lamp/display may not illuminate immediately in the event of a tyre blow-out or rapid leak.

NOTE

- To avoid the risk of damage to the tyre inflation pressure sensors, have any punctured tyre repaired by a MITSUBISHI MOTORS Authorized Service Point. If the tyre repair is not done by a MITSUBISHI MOTORS Authorized Service Point, damage to the tyre inflation pressure sensor is not covered by your warranty.
- Do not use an aerosol puncture-repair spray on any tyre.
Such a spray could damage the tyre inflation pressure sensors.
Have any puncture repaired by a MITSUBISHI MOTORS Authorized Service Point.

NOTE

- Using the tyre repair kit may damage the tyre inflation pressure sensor. The vehicle must promptly be inspected and repaired by a MITSUBISHI MOTORS Authorized Service Point after using the tyre repair kit.

The tyre pressure monitoring system (TPMS) may not work normally in the following circumstances:

- A wireless facility or device using the same frequency is near the vehicle.
- Snow or ice is stuck inside the fenders and/or on the wheels.
- The tyre inflation pressure sensor's battery is dead.
- Wheels other than MITSUBISHI MOTORS GENUINE wheels are being used.
- Wheels that are not fitted with tyre inflation pressure sensors are being used.
- Wheels whose ID codes are not memorized by the vehicle are used.
- A window tint that affects the radio wave signals is installed.

7

Tyre pressure monitoring system (TPMS)

NOTE

- Tyre inflation pressures vary with the ambient temperature. If the vehicle is subjected to large variations in ambient temperature, the tyre inflation pressures may be underinflated (causing the warning lamp/display come on) when the ambient temperature is relatively low. If the warning lamp/display comes on, adjust the tyre inflation pressure.

7

Whenever the tyres and wheels are replaced with new ones

E00637400025

If new wheels with new tyre inflation pressure sensors are installed, their ID codes must be programmed into the tyre pressure monitoring system. Have tyre and wheel replacement performed by a MITSUBISHI MOTORS Authorized Service Point to avoid the risk of damaging the tyre inflation pressure sensors. If the wheel replacement is not done by a MITSUBISHI MOTORS Authorized Service Point, it is not covered by your warranty.

CAUTION

- The use of non-genuine wheels will prevent the proper fit of the tyre inflation pressure sensors, resulting air leakage or damage of the sensors.

Reset of low tyre pressure warning threshold

E00637500169

The threshold is set based on the tyre pressure which the reset function is executed by following procedure.

1. Operate the multi-information display switch to switch the information screen to the menu screen.
Refer to “Multi information display switch” on page 6-06.
Refer to “Changing the function settings” on page 6-17.
2. Lightly press the multi-information display switch to select “ RESET” (reset of low tyre pressure warning threshold).
3. Hold down the multi-information display switch for about 3 seconds or more, the buzzer sounds.

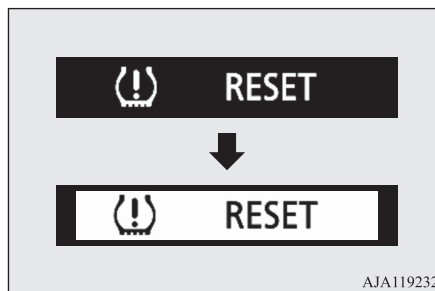

4. The warning lamp start flashing slowly.

5. Drive for a while. The reset is completed if the warning lamp goes out.

NOTE

- The reset function should be executed every time when the tyre pressure or tyre rotation is adjusted.
- The reset function should be executed when the tyre is cold. If it is executed when the tyre is warm (e.g. after driving), there may be a low tyre pressure warning earlier than usual.

Tyre ID set change

E00637600173

In case that 2 sets of tyre inflation pressure sensor ID are registered in the receiver, the valid tyre ID set can be changed by following procedure.

1. Operate the multi-information display switch to switch the information screen to the menu screen.
Refer to “Multi information display switch” on page 6-06.
Refer to “Changing the function settings” on page 6-17.
2. Lightly press the multi-information display switch to select “ 1 - 2” (tyre ID set change).

3. Hold down the multi-information display switch for about 3 seconds or more. The setting changes the selected tyre ID set.

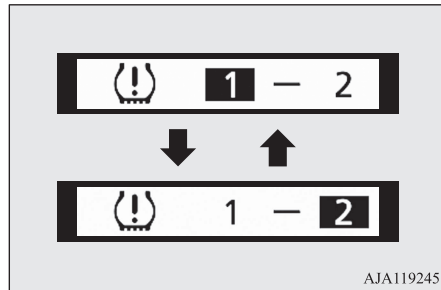

4. The valid tyre ID set is changed, and the number of the tyre pressure monitoring system (TPMS) SET indicator is changed.

NOTE

- Each time this procedure is done, the tyre ID set is changed. (1 - 2 - 1 - 2 ...)
- The tyre ID set is NOT changed, in case that only 1 set of ID is registered.

NOTE

- When changing the tyre ID set, the reset function of low tyre pressure warning threshold is automatically started. (The warning lamp starts flashing slowly.) If the tyre is warm at this time, the reset function should be executed again when the tyre is cold.

Reversing sensor system*

E00615501515

This system operates when you are backing the vehicle. It uses corner and back sensors to detect an obstacle and the information screen in the multi information display and the buzzer to inform you of the approximate distance to the obstacle.

CAUTION

- The reversing sensor system assists you in determining the approximate distance between the vehicle and an obstacle located behind the vehicle. It has limitations in terms of detectable areas and objects, and may not properly detect some objects. Therefore, do not place excessive confidence in the reversing sensor system and operate the vehicle as carefully as you would do with a vehicle not equipped with this system.

CAUTION

- Make sure to check the surroundings with your own eyes to ensure safety. Do not operate the vehicle by relying on the reversing sensor system alone.

Obstacle detection areas

E00615601718

The detection areas of the corner and back sensors are limited to those shown in the illustration. Moreover, the sensors are unable to detect low or thin objects or objects near the rear bumper. Thus, make sure to check the surroundings as you operate the vehicle in a safe manner.

7

Reversing sensor system*

Corner and back sensor locations

There are two corner sensors (A) at the corners of the rear bumper, and two back sensors (B) in the centre of the rear bumper.

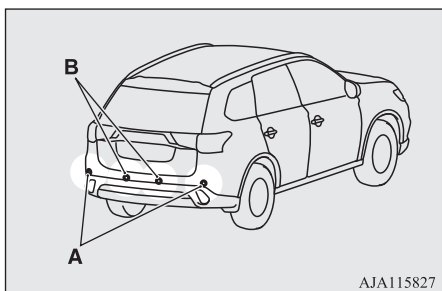

Reversing sensor system detection areas

Depending on whether the vehicle is equipped with a towing bar, you can change the reversing sensor system between the standard mode and the towing bar mode. The towing bar mode changes the system to exclude the area in which the towing bar is mounted from the detection areas.

Vehicles without a towing bar

The detection areas are within approximately 60 cm (A) from the corner sensors, 125 cm (B) from the back sensors.

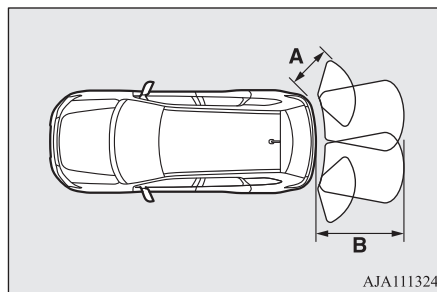

Vehicles with a towing bar

The detection areas are within approximately 60 cm (A) from the corner sensors, 125 cm (B) from the back sensors. The non-detection areas (C) are within approximately 20 cm (D) from the bumper.

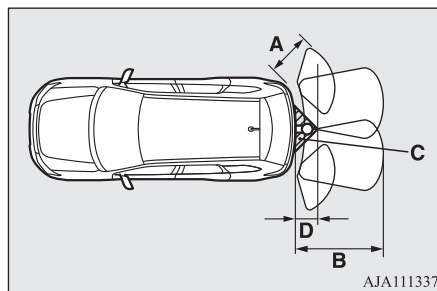

NOTE

- The sensors do not detect objects located in the area directly below or near the bumper. If the height of an object is lower than the mounted position of the corner or back sensors, the sensors may not continue detecting it even if they detected it initially.

For information on how to change the detection areas, please refer to “Changing the detection areas” on page 7-100.

CAUTION

- The reversing sensor system may not operate properly under the following conditions:
 - The sensors or surroundings have been wiped by hand.
 - The stickers or accessories have been attached to the sensors or surroundings.
 - The sensors or surroundings are covered with ice, snow, or mud.
 - When the temperature difference is too large.
 - The sensors are frozen.
 - The system receives ultrasonic noise from other sources (the horns of other vehicles, motorcycle engines, brakes, radios, pouring rain, splashing water, snow traction device (tyre chains), etc.).
 - The sensors are extremely hot or cold (while the vehicle is parked for a long period of time under a blazing sun or in cold weather).

CAUTION

- The vehicle tilts significantly.
- The vehicle is driven on a rough road (with a bumpy, gravel, hilly, or grassy surface).
- The vehicle is too close to an obstacle.
- Immediately after Plug-in Hybrid EV System starting.
- The reversing sensor system may not properly detect the following objects:
 - Objects that are thin, such as wire nets or ropes.
 - Objects that absorb sound waves, such as snow.
 - Objects that are shaped with a sharp angle.
 - Objects with a smooth surface, such as glass.
 - Objects that are low, such as kerbstones.
- If the bumper has been exposed to an impact, the sensors may fail and prevent the system from functioning properly. Have the vehicle inspected at a MITSUBISHI MOTORS Authorized Service Point.

NOTE

- The buzzer may sound lower than the normal warning sound when the reversing sensor system is receiving ultrasonic noise from other sources, but this is not a malfunction. The buzzer will stop sounding and the system will return to normal operation after the noise is no longer received.

To operate

E00615702136

To operate the system, move the selector lever to the “R” position while the operation mode is put in ON. When the reversing sensor system is operated, the reversing sensor system operation indication lamp (A) will turn on. To stop the operation, push the “SONAR” switch; the reversing sensor system operation indication lamp (A) goes out.

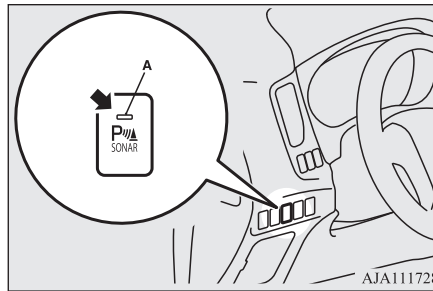

AJA111728

NOTE

- Only when the select position is the “R” position, the reversing sensor system can be operated or be stopped by using the “SONAR” switch.

Warning for obstacles

If there is an obstacle behind the vehicle, a warning will be issued with the information screen in the multi information display and a warning buzzer.

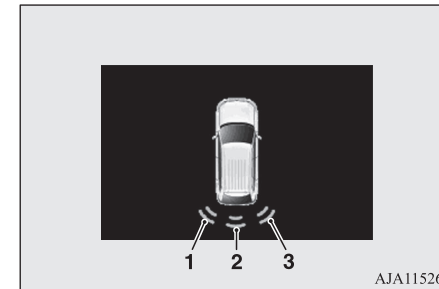

AJA115263

- 1- Corner sensor (left)
- 2- Back sensor
- 3- Corner sensor (right)

Corner sensor

Vehicle to obstacle distance	Warning display/ sound cycle
Approx. 60 to 40 cm	Intermittent
Approx. 40 to 30 cm	Fast intermittent
Within approx. 30 cm	Continuous

7

Reversing sensor system*

Back sensor (vehicles without a towing bar)

Vehicle to obstacle distance	Warning display/sound cycle
Approx. 125 to 80 cm	Intermittent
Approx. 80 to 40 cm	Fast intermittent
Within approx. 40 cm	Continuous

7

Back sensor (vehicles with a towing bar)

Vehicle to obstacle distance	Warning display/sound cycle
Approx. 125 to 100 cm	Intermittent
Approx. 100 to 60 cm	Fast intermittent
Within approx. 60 cm	Continuous

CAUTION

- The distances given are to be used for reference only, as errors may be caused by various factors, such as temperature, humidity, or the shape of the obstacles.

NOTE

- When the sensors are detecting different obstacles at the same time, the information screen in the multi information display indicates the directions of the obstacles each sensor is detecting. However, closer obstacles are given priority over other detected obstacles and the warning buzzer sounds to inform you of closer obstacles.

Changing the detection areas

E00615801257

The detection areas can be changed as follows:

Vehicles with a towing bar

While the operation of the system is stopped at the “SONAR” switch, push the “SONAR” switch approximately 3 seconds or more, and release it. The buzzer sounds twice to indicate that the detection area has been changed.

Vehicles without a towing bar

While the operation of the system is stopped at the “SONAR” switch, push the “SONAR” switch approximately 3 seconds or more, and release it. The buzzer sounds once to indicate that the detection area has been changed.

NOTE

- The detection area will not change if you keep the “SONAR” switch pushed for 10 seconds or more.
- After pushing the “SONAR” switch, reversing sensor system operation differs according to the detection area setting.
 - Setting when towing bar is not equipped
When the selector lever is moved to the “R” position, the reversing sensor system will operate even if the corner sensor operation was stopped by pushing the “SONAR” switch.
 - Setting when towing bar is equipped
When the reversing sensor system operation was stopped by pushing the “SONAR” switch, the reversing sensor system will not operate until the Plug-in Hybrid EV System has been stopped even if the selector lever is moved to the “R” position.
To resume the reversing sensor system operation, push the “SONAR” switch or stop and restart the Plug-in Hybrid EV System, and then move the selector lever to the “R” position.

Reversing sensor system warning display

E00615901519

In case there is a malfunction in the reversing sensor system, the display for the malfunctioning sensor will blink and the warning buzzer will sound for approximately 5 seconds.

Example: Corner sensor (left) malfunctioning



AJA115276

Even after the buzzer and display has stopped warning, the indication lamp (A) on “SONAR” switch will continue blinking until the system reverts to the normal state. Have the vehicle inspected at a MITSUBISHI MOTORS Authorized Service Point.

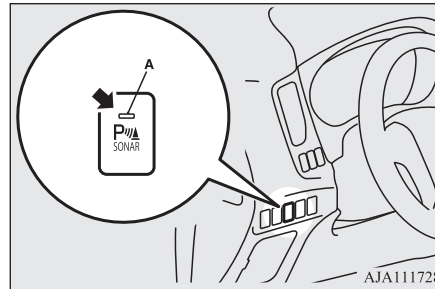

AJA111728

Parking sensors (Front/Rear)*

E00647700092

When parking in a garage or during parallel parking, these sensors alert the driver to any objects near the vehicle and their distance, through a buzzer and the sensor display on the information screen in the multi-information display.

Parking sensors (Front/Rear)*

CAUTION

- The parking sensors assist you in determining the approximate distance between the vehicle and any objects. It has limitations in terms of detectable areas and objects, and may not properly detect some objects. Therefore, do not place excessive confidence in the parking sensors, and operate the vehicle as carefully as you would do with vehicle not equipped with this system.
- Make sure to check the surroundings with your own eyes to ensure safety. Do not operate the vehicle by relying on the parking sensors alone.

7

Obstacle detection areas

E00647800136

The detection areas of the corner and back sensors are limited to those shown in the illustration. Moreover, the sensors are unable to detect low or thin objects or objects near the front or rear bumper. Thus, make sure to check the surroundings as you operate the vehicle in a safe manner.

Parking sensors (Front/Rear)*

Corner and back sensor locations

There are 8 sensors (A) in the front and rear bumper.

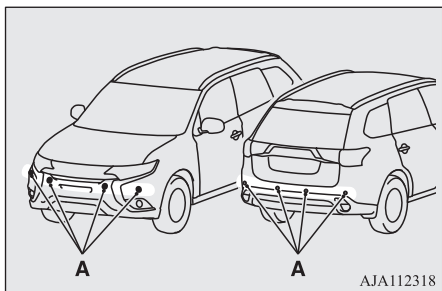

Detection areas

Depending on whether the vehicle is equipped with a towing bar, you can change the parking sensors between the standard mode and the towing bar mode. The towing bar mode changes the system to exclude the area in which the towing bar is mounted from the detection areas.

Vehicles without a towing bar

The detection areas are within approximately 60 cm (A) from the front and corner sensors and 125 cm (B) from the back sensors.

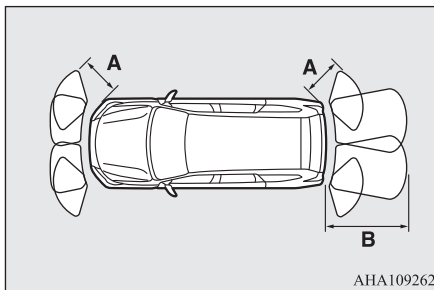

Vehicles with a towing bar

The detection areas are within approximately 60 cm (A) from the front and corner sensors and 125 cm (B) from the back sensors. The non-detection areas (C) are within approximately 20 cm (D) from the bumper.

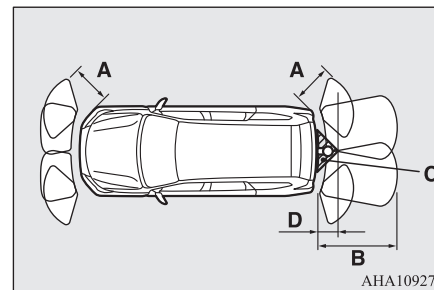

NOTE

- The sensors do not detect objects located in the area directly below or near the bumper. If the height of an object is lower than the mounted position of the sensors, the sensors may not continue detecting it even if they detected it initially.

For information on how to change the detection areas, please refer to “Changing the detection areas” on page 7-100.

Parking sensors (Front/Rear)*

CAUTION

- The parking sensors may not operate properly under the following conditions:
 - The sensors or surroundings have been wiped by hand.
 - The stickers or accessories have been attached to the sensors or surroundings.
 - The sensors or surroundings are covered with ice, snow, or mud.
 - When the temperature difference is too large.
 - The sensors are frozen.
 - The system receives ultrasonic noise from other sources (the horns of other vehicles, motorcycle engines, brakes, radios, pouring rain, splashing water, snow traction device (tyre chains), etc.).
 - The sensors are extremely hot or cold (while the vehicle is parked for a long period of time under a blazing sun or in cold weather).
 - The vehicle tilts significantly.
 - The vehicle is driven on a rough road (with a bumpy, gravel, hilly, or grassy surface).
 - The vehicle is too close to an obstacle.
 - Immediately after Plug-in Hybrid EV System starting.
- The parking sensors may not properly detect the following objects:
 - Objects that are thin, such as wire nets or ropes.
 - Objects that absorb sound waves, such as snow.
 - Objects that are shaped with a sharp angle.

CAUTION

- Objects with a smooth surface, such as glass.
- Objects that are low, such as kerbstones.
- If the bumper has been exposed to an impact, the sensors may fail and prevent the system from functioning properly. Have the vehicle inspected at a MITSUBISHI MOTORS Authorized Service Point.

NOTE

- When the sensor is received ultrasonic noise from outside, the sensor of the corresponding portion will blink at a constant frequency. When they are not received the noise and return to normal operation.

To operate

E00648100149

To operate the system, the operation mode is put in ON. When the parking sensors are operated, the indication lamp (A) will turn on. To stop the operation, press the “SONAR” switch and the indication lamp (A) goes off.

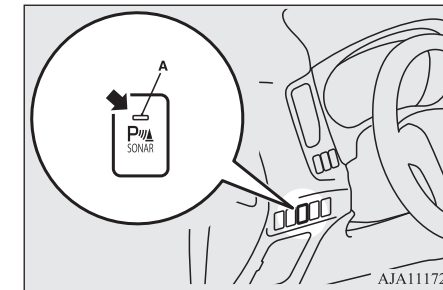

7

Parking sensors (Front/Rear)*

Warning for obstacles

If there is an obstacle in the vicinity of the vehicle, a warning will be issued with the information screen in the multi information display and a warning buzzer.

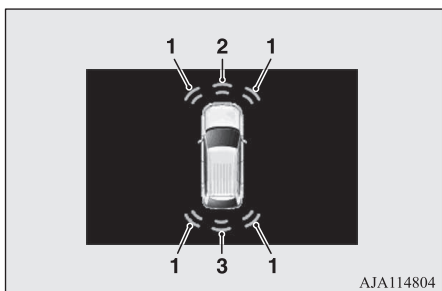

7

- 1- Corner sensor
- 2- Front sensor
- 3- Back sensor

Front and corner sensor

Vehicle to obstacle distance	Warning display/sound cycle
Approx. 60 to 40 cm	Intermittent
Approx. 40 to 30 cm	Fast intermittent
Within approx. 30 cm	Continuous

Back sensor (vehicles without a towing bar)

Vehicle to obstacle distance	Warning display/sound cycle
Approx. 125 to 80 cm	Intermittent
Approx. 80 to 40 cm	Fast intermittent
Within approx. 40 cm	Continuous

Back sensor (vehicles with a towing bar)

Vehicle to obstacle distance	Warning display/sound cycle
Approx. 125 to 100 cm	Intermittent
Approx. 100 to 60 cm	Fast intermittent
Within approx. 60 cm	Continuous

CAUTION

- The distances given are to be used for reference only, as errors may be caused by various factors, such as temperature, humidity, or the shape of the obstacles.

NOTE

- When the sensors are detecting different obstacles at the same time, the information screen in the multi information display indicates the directions of the obstacles each sensor is detecting. However, closer obstacles are given priority over other detected obstacles and the warning buzzer sounds to inform you of closer obstacles.

Changing the detection areas

E0064820094

The detection areas can be changed as follows:

Vehicles with a towing bar

While the operation of the system is stopped at the "SONAR" switch, press the "SONAR" switch approximately 3 seconds or more, and release it. The buzzer sounds twice to indicate that the detection area has been changed.

Vehicles without a towing bar

While the operation of the system is stopped at the "SONAR" switch, press the "SONAR" switch approximately 3 seconds or more, and release it. The buzzer sounds once to indicate that the detection area has been changed.

NOTE

- The mode of the detection area can be switched only when the select position is in the “R” (REVERSE) position.
- The detection area will not change if you keep the “SONAR” switch pressed for 10 seconds or more.
- After pressing the “SONAR” switch, the parking sensors operation differs according to the detection area setting.
 - Setting when towing bar is not equipped
When the selector lever is moved to the “R” (REVERSE) position, the parking sensors will operate even if the parking sensors operation was stopped by pressing the “SONAR” switch.
 - Setting when towing bar is equipped
When the parking sensors operation was stopped by pressing the “SONAR” switch, the parking sensors will not operate until the Plug-in Hybrid EV System has been stopped even if the select position is put to the “R” (REVERSE) position.
To resume the parking sensors operation, press the “SONAR” switch or stop and restart the Plug-in Hybrid EV System, and then put the select position to the “R” (REVERSE) position.

Warning display

E00648300125

In case there is a malfunction in the parking sensors, the display for the malfunctioning sensor will blink and the warning buzzer will sound for approximately 5 seconds.

Example: Corner sensor (left) malfunctioning



AJA115276

Rear-view camera*

Even after the buzzer and display has stopped warning, the indication lamp (A) on “SONAR” switch will continue blinking until the system reverts to the normal state. Have the vehicle inspected at a MITSUBISHI MOTORS Authorized Service Point.

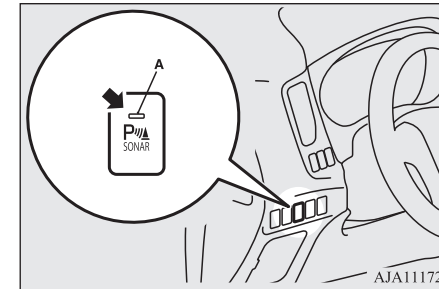

AJA11728

Rear-view camera*

E00618402684

The rear-view camera is a system that shows the view behind the vehicle on a screen of the DISPLAY AUDIO, the Smartphone Link Display Audio or the MITSUBISHI Multi-Communication System (MMCS).

7

Rear-view camera*

⚠ CAUTION

- The rear-view camera is an assistance system that enables the driver to check for obstacles behind the vehicle. Its range of view is limited, so you should not overly depend on it. Please drive just as carefully as you would if the vehicle did not have the rear-view camera.
- Be sure to visually confirm safety around the vehicle with your own eyes. Do not depend entirely on the rear-view camera.

7

Range of view of rear-view camera

The range of view of the rear-view camera is limited to the area shown in the illustrations. It cannot show both sides and the lower part of the rear bumper, etc.

When reversing, be sure to visually confirm safety around the vehicle.

Location of rear-view camera

The rear-view camera (A) is integrated into the part near the tailgate handle.

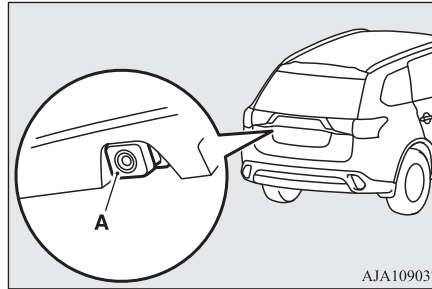

AJA109037

Range of view of rear-view camera

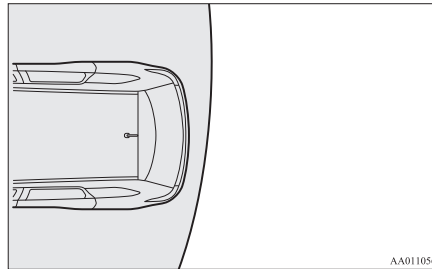

AA0110565

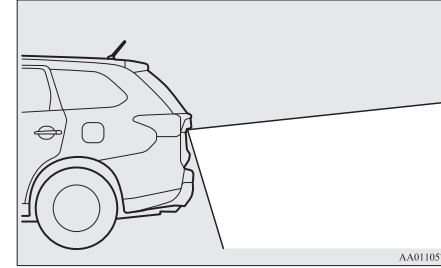

AA0110578

How to use the rear-view camera

When you put the select position to the “R” position with the operation mode in ON, the view behind the vehicle will automatically appear on the screen of the DISPLAY AUDIO, the Smartphone Link Display Audio or the MITSUBISHI Multi-Communication System (MMCS). When you put the select position to any other position, the screen will return to its original indication.

⚠ CAUTION

- The rear-view camera has a special lens that can make objects shown on the screen appear to be closer or further away than they actually are.

NOTE

- Because the rear-view camera has a special lens, the lines on the ground between parking spaces may not look parallel on the screen.
- In the following situations, the screen indication may be difficult to see. There is no abnormality.
 - Low light (nighttime).
 - When the light of the sun or the light from a vehicle's headlamps shines directly into the lens.
- If the camera is hot and is then cooled by rain or a car wash, the lens can mist up. This phenomenon does not indicate a malfunction.
- It is not possible to fully see obstacles when the lens is dirty. If the lens becomes contaminated by water droplets, snow, mud or oil, wipe off the contamination, taking care not to scratch the lens.
- Please observe the following cautions. Ignoring them could lead to a camera malfunction.
 - Do not subject the camera to physical shock.
 - Do not apply wax to the camera.
 - Do not splash the camera with boiling water.
 - Do not disassemble the camera.

Reference lines on the screen

E00649100061

Reference lines and upper surface of the rear bumper (A) are displayed on the screen.

- Red line (B) indicates approximately 50 cm behind the rear bumper.
- Two Green lines (C) indicate approximately 20 cm outside of the vehicle body.
- Short transverse lines (1 to 3) indicate distance from the rear bumper.

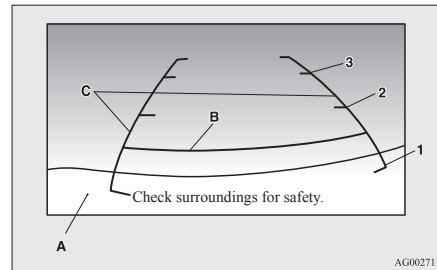

1. Approximately at the rear edge of the rear bumper (if so equipped)
2. Approximately 100 cm
3. Approximately 200 cm

Errors between the display and the actual road surface

The reference lines for distance and vehicle width are based on a level, flat road surface. In the following cases, errors are produced between the display reference lines and the distance on the actual road surface.

When the rear of the vehicle is weighed down with the weight of passengers and luggage in the vehicle

The reference lines are displayed closer than the actual distance. Therefore when there is an obstacle on the upward slope, it appears farther than its actual position.

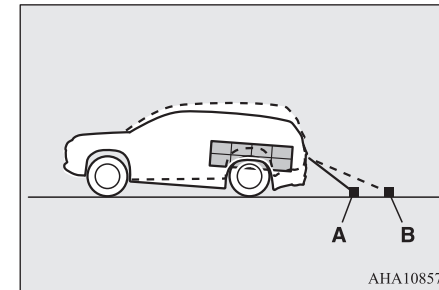

- A: Actual objects
- B: Objects shown on the screen

When there is an upward slope behind the vehicle

The reference lines are displayed closer than the actual distance.

Rear-view camera*

Therefore when there is an obstacle on the upward slope, it appears farther than its actual position.

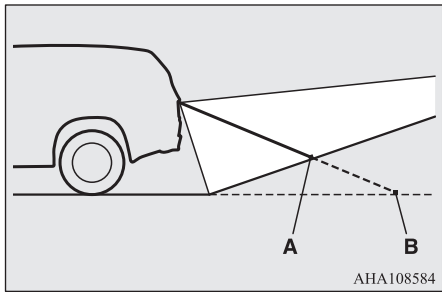

- A: Actual objects
- B: Objects shown on the screen

When there is a downward slope behind the vehicle

The reference lines are displayed farther than the actual distance.

Therefore when there is an obstacle on the downward slope, it appears closer than its actual position.

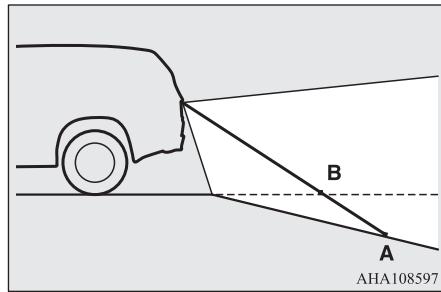

- A: Actual objects
- B: Objects shown on the screen

When solid objects are located close to the vehicle

When solid objects are located close to the vehicle, the displayed distance on the screen may differ from the actual distance. Because the reference lines do not contact the body of the truck, it looks as if it would not hit the vehicle in following illustration.

However, the vehicle may hit the truck because the body of the truck strays onto the course in reality.

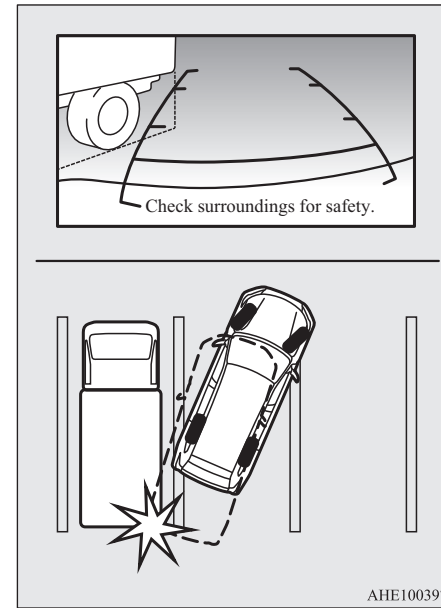

7

When approaching to solid objects

The reference lines for distance and vehicle width are intended to indicate the distance to a flat object such as a level, flat road surface. This may make the distance to a projecting object shown on the screen differ from the actual distance to the projecting object. Do not use them as a guide for distances to solid objects.

Example: On the screen the point B appears the nearest, then the point C and A in order of distance. The points A and B actually are the same distances from the vehicle, and the point C is farther off than the points A and B.

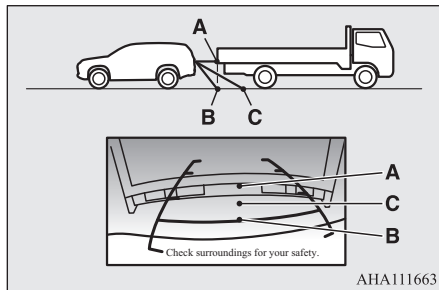

Multi Around Monitor*

E00645000310

The Multi Around Monitor is a system that shows the view combined with four cameras, i.e., “Front-view camera”, “Side-view cameras (right and left)” and “Rear-view camera” on a screen of the DISPLAY AUDIO, the Smartphone Link Display Audio or the MITSUBISHI Multi-Communication System (MMCS). It assists drivers to park their vehicles in parking spaces and to parallel park their vehicles.

CAUTION

- The Multi Around Monitor is an assistance system that enables the driver to check the safety around the vehicle. The range where the image can be displayed is limited. Do not place too much confidence in the Multi Around Monitor and try to drive carefully in the same way as for the vehicle not equipped with the Multi Around Monitor. Its range of view is limited, so you should not overly depend on it. Please drive just as carefully as you would if the vehicle did not have the Multi Around Monitor.
- Be sure to visually confirm safety around the vehicle with your own eyes. Especially, the four corners of the vehicle become blind spots where an object is not displayed on the Multi Around Monitor. Do not depend entirely on the Multi Around Monitor.

CAUTION

- Do not use the Multi Around Monitor with the door mirrors folded in and/or with the doors and/or the tailgate open. It will prevent the Multi Around Monitor from displaying the appropriate range.

Location of each cameras

The cameras are integrated into the location as shown below.

7

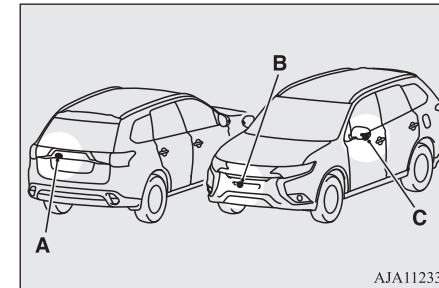

- A: Rear-view camera
- B: Front-view camera
- C: Side-view camera

Multi Around Monitor*

⚠ WARNING

- Do not install anything which will disturb the operation of the cameras around the location of them.

Range of view of the Multi Around Monitor

E00645100252

The range of view of the Multi Around Monitor cameras is limited to the area shown in the illustrations. It cannot show around the both sides and the lower part of the front and rear bumpers, etc. While driving, be sure to visually confirm safety around the vehicle.

Range of view of the Multi Around Monitor cameras

7

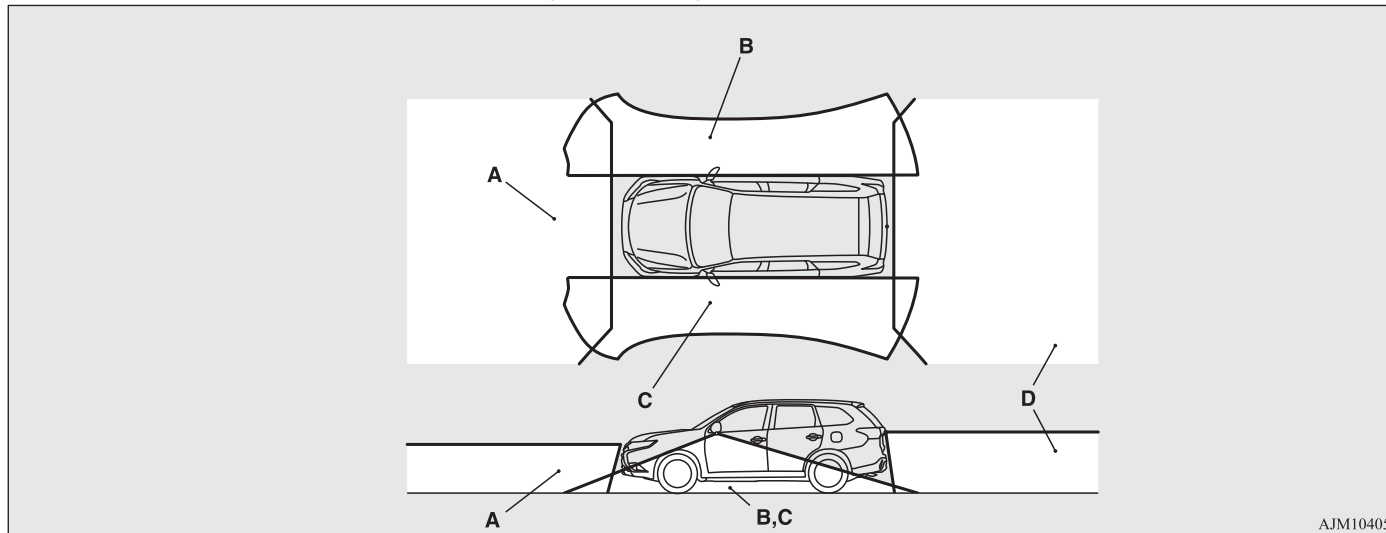

AJM104052

- A: Front-view camera
- B: Side-view camera (Right)
- C: Side-view camera (Left)

- D: Rear-view camera

Types of views of the Multi Around Monitor

Two different types of views are displayed on the left side and the right side respectively.

Bird's eye-view/Rear-view mode

Views of the surroundings of the vehicle and behind the vehicle are displayed.

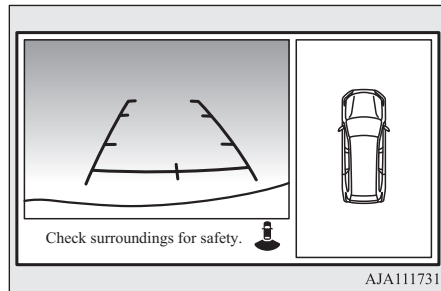

Side-view/Rear-view mode

Views of the passenger's side of the vehicle and behind the vehicle are displayed.

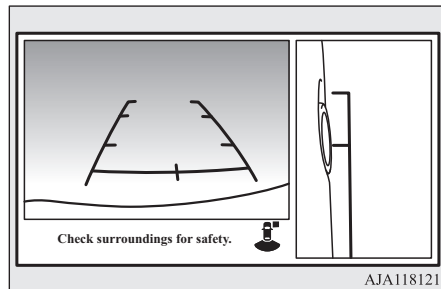

Bird's eye-view/Front-view mode

Views of the surroundings of the vehicle and the front of the vehicle are displayed.

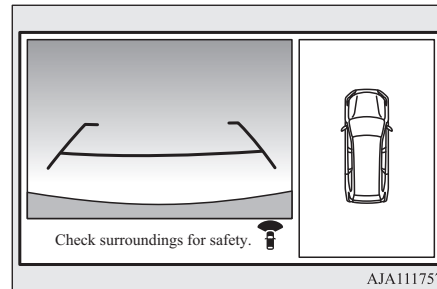

Side-view/Front-view mode

Views of the passenger's side of the vehicle and the front of the vehicle are displayed.

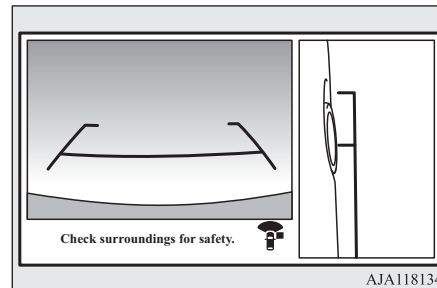

CAUTION

- The cameras have special lenses that can make objects shown on the screen appear to be closer or further away than they actually are.

NOTE

- Because the cameras have a special lens, the lines on the ground between parking spaces may not look parallel on the screen.
- In the following situations, the screen indication may be difficult to see. There is no abnormality.
 - Low light (nighttime).
 - When the light of the sun or the light from a vehicle's headlamps shines directly into the lens.
 - If a fluorescent light shines directly into the lens, the screen indication may be flicker.
 - There is no abnormality.
- If the camera is hot and is then cooled by rain or a car wash, the lens can mist up. This phenomenon does not indicate a malfunction.
- If the atmospheric temperature is extremely hot or extremely cold, the camera images may not be clear.
 - There is no abnormality.
- If a radio set is installed near the camera, the camera images may cause electrical system interference and the system may stop functioning properly.

Multi Around Monitor*

NOTE

- It is not possible to fully see obstacles when the lens is dirty. If the lens becomes contaminated by water droplets, snow, mud or oil, wipe off the contamination, taking care not to scratch the lens.
- Please observe the following cautions. Ignoring them could lead to a camera malfunction.
 - Do not subject the camera to physical shock such as striking it strongly or throwing a thing.
 - Do not adhere organic substances, waxes, oil remover, and glass cleaner to the camera.
If adhered to them, immediately wipe off.
 - Do not splash the camera with boiling water.
 - Never spray or splash water on the camera or around it.
 - Do not disconnect, disassemble or modify the camera.
 - Do not scratch the camera, as this may cause damage to the camera images.

7

How to use the Multi Around Monitor

E0065000031

The Multi Around Monitor can only be used when the operation mode is ON.

Operation with the selector lever

E00652700175

When you put the select position to the “R” (REVERSE) position, the bird’s eye-view/rear-view is displayed on the screen of the DISPLAY AUDIO, the Smartphone Link Display Audio or the MITSUBISHI Multi-communication System (MMCS). When you put the select position to any other position, the display disappears.

NOTE

- The passenger’s side screen can be switched to the side-view by pressing the switch.

Operation with the switch

E00652800105

When the switch (A) is pressed, the bird’s eye view/front-view is displayed.

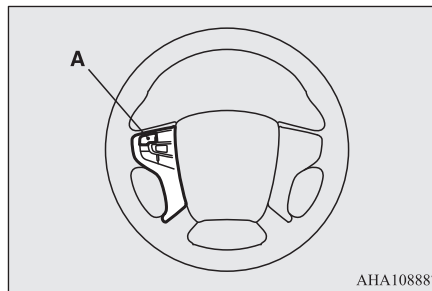

AHA108887

NOTE

- If there is no operation for 3 minutes after the Multi Around Monitor is displayed by pressing the switch with the select position in a position other than “R”, the display disappears.

Switching of the screen (Select position is “R”)

E00652900278

If the switch is pressed, the mode of Multi Around Monitor is switched as follows.

Bird’s eye-view/Rear-view mode → Side-view/ Rear-view mode

Switching of the screen (Select position is other than “R”)

E00652900281

If the switch is pressed, the mode of Multi Around Monitor is switched as follows.

Bird’s eye-view/ Front-view mode → Side-view/Front-view mode → OFF

NOTE

- When you put the select position to the “R” (REVERSE) position with the front-view displayed on the driver’s side screen, the driver’s side screen switches to the rear-view mode. When you put the select position to any other position, the driver’s side screen switches to the front-view mode.
- When the switch is pressed at the vehicle speed of approximately 10 km/h (6 mph) or higher, only the side-view can be displayed on the passenger’s side screen.
- The front-view will not be displayed when the vehicle speed exceeds approximately 10 km/h (6 mph).
- The display of the view may be delayed during switching of the screen.

How to read the screen

E00645400079

In any mode other than the Bird’s eye-view mode, the lines in the screen give the following information. Use them only as a guide.

CAUTION

- When you accidentally hit the camera and its circumference against something, the view and the lines in the screen may not be displayed correctly. Be sure to have it inspected by a MITSUBISHI MOTORS Authorized Service Point.

Front-view mode

Reference lines for the distance and the vehicle width and upper surface of the front bumper (A) are displayed on the screen.

- The Red line (B) indicates approximately 50 cm from the front edge of the front bumper.
- The Two Green lines (C) indicate the approximate vehicle width.
- The Orange line (D) indicates an expected course when the vehicle moves forward with the steering wheel turned. It disappears when the steering wheel is in the neutral position.
- The approximate distance from the vehicle body is as follows:

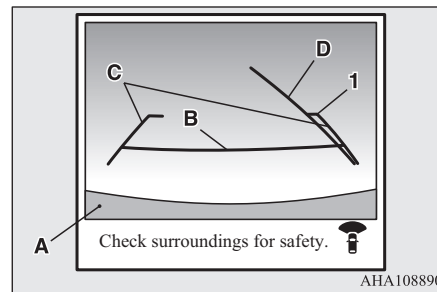

1- Approximately 100 cm from the front edge of the front bumper

NOTE

- When the expected course lines are displayed in the front-view, the expected course lines are also displayed in the bird’s eyeview (Front: solid line, Rear: broken line).

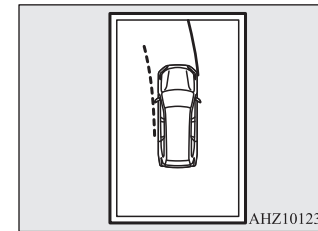
**Rear-view mode**

E00645600084

Reference lines for the distance and the vehicle width and upper surface of the rear bumper (A) are displayed on the screen.

- The Red line (B) indicates approximately 50 cm behind the rear edge of the rear bumper.
- The Two Green lines (C) indicate the approximate vehicle width.
- The Orange line (D) indicates an expected course when the vehicle is reserved with the steering wheel turned. It disappears when the steering wheel is in the neutral position.
- The approximate distance from the vehicle body is as follows:

Starting and driving 7-113

Multi Around Monitor*

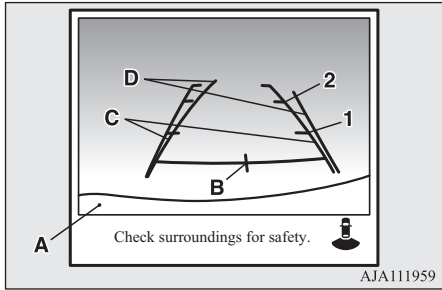

7

- 1- Approximately 100 cm from the rear edge of the rear bumper
- 2- Approximately 200 cm from the rear edge of the rear bumper

CAUTION

Due to the number of people in the vehicle, the fuel quantity, the weight and positioning of luggage, and/or the condition of the road surface, the lines in the view from the rear-view camera may not be accurately positioned relative to the actual road. Use the reference lines only as a guideline, and always do a safety check of your behind and surroundings directly while driving.

NOTE

- When the expected course lines are displayed in the rear-view, the expected course lines are also displayed in the bird's eye-view (Front: broken line, Rear: solid line).

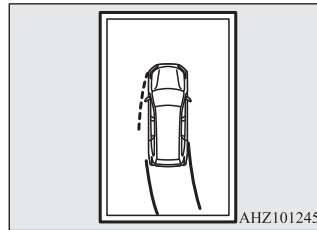

Errors between the display and the actual road surface

E00645900045

The reference lines for distance and vehicle width are based on a level, flat road surface. In the following cases, errors are produced between the display reference lines and the distance on the actual road surface.

When the rear of the vehicle is weighed down with the weight of passengers and luggage in the vehicle

The reference lines are displayed closer than the actual distance.

Therefore when there is an obstacle on the upward slope, it appears farther than its actual position.

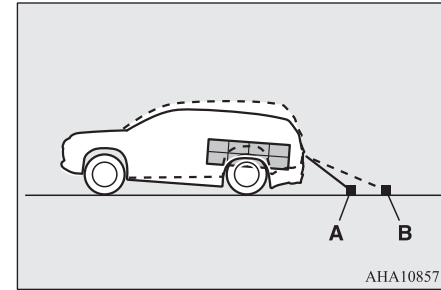

- A: Actual objects
- B: Objects shown on the screen

When there is an upward slope behind the vehicle

The reference lines are displayed closer than the actual distance.

Multi Around Monitor*

Therefore when there is an obstacle on the upward slope, it appears farther than its actual position.

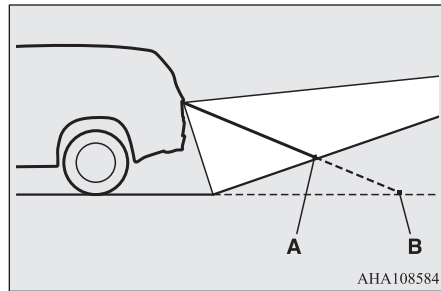

- A: Actual objects
- B: Objects shown on the screen

When there is a downward slope behind the vehicle

The reference lines are displayed farther than the actual distance.

Therefore when there is an obstacle on the downward slope, it appears closer than its actual position.

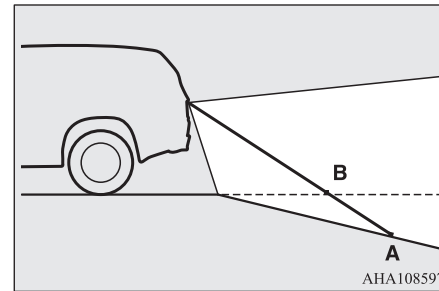

- A: Actual objects
- B: Objects shown on the screen

When solid objects are located close to the vehicle

When solid objects are located close to the vehicle, the displayed distance on the screen may differ from the actual distance. Because the reference lines do not contact the body of the truck, it looks as if it would not hit the vehicle in following illustration.

However, the vehicle may hit the truck because the body of the truck strays onto the course in reality.

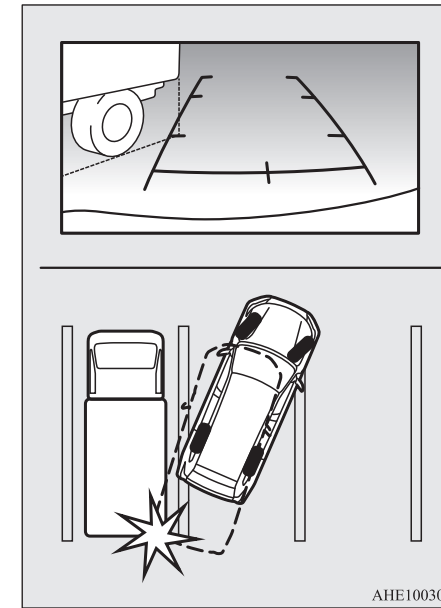

7

Multi Around Monitor*

When approaching to solid objects

The reference lines for distance and vehicle width are intended to indicate the distance to a flat object such as a level, flat road surface. This may make the distance to a projecting object shown on the screen differ from the actual distance to the projecting object. Do not use them as a guide for distances to solid objects.

Example: On the screen the point B appears the nearest, then the point C and A in order of distance. The points A and B actually are the same distances from the vehicle, and the point C is farther off than the points A and B.

7

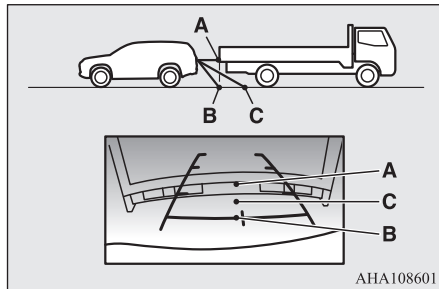

Side-view mode

E00646100060

Reference lines for the vehicle width and the front end of the vehicle are displayed on the screen.

7-116 Starting and driving

- 1- Approximate vehicle width including the door mirror.
- 2- Approximate location of the axle centre of the front wheel.
- 3- Approximate 50 cm from the front edge of the front bumper.

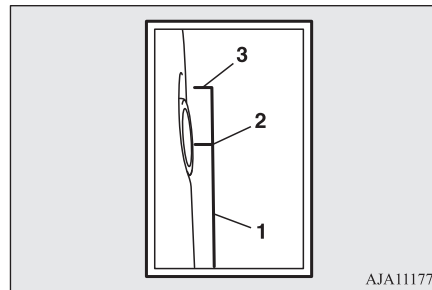

Bird's eye-view mode

E00646200058

An overhead view in which the vehicle is looked down is displayed so that you can easily identify the location of your vehicle and the course to enter the parking space.

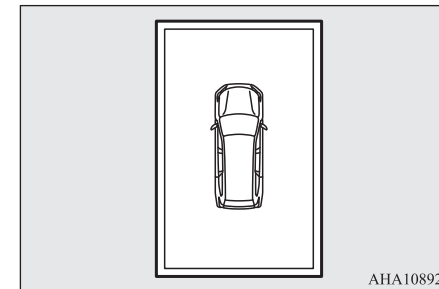

OGGE19E1

⚠ CAUTION

- The bird's eye-view is an simulated view processed by combining view captured by "Front-view camera", "Side-view cameras (right and left)" and "Rear-view camera". Because of this, in the Bird's eye-view mode, objects will appear to be farther away than they actually are. In addition, there are blind spots in the vicinity of the actual vehicle which are not displayed on the screen. You may crash your vehicle even if there seems to be a little distance between your vehicle and an object, and there may be an object in the area where there seems to be nothing. Be sure to check the safety around the vehicle with your own eyes.
- The vehicle icon displayed in the Bird's eye-view mode differs from the actual vehicle in colour and size. Because of this, an object near the vehicle may appear to be in contact with the vehicle, and the positional relationship between the vehicle and the object may differ from the actual one.
- The view composition processing regions are present in the four corners of the Bird's eye-view display, mainly at the boundary sections of views from each camera. Because of this, in the vicinity of the boundary sections, the sharpness of the views may decrease and an object may disappear and reappear on the screen.

📖 NOTE

- In the Bird's eye-view mode, since the views captured by the four cameras, "Front-view camera", "Side-view cameras (right and left)" and "Rear-view camera" are processed based on a level flat road surface, an image may be displayed as follows:
 - An object appears to have fallen down and looks longer or larger.
 - An object having a height from the road surface may seem to appear from the joint of the view composition processing regions.
- The brightness of the views from each camera may vary depending on the illuminance conditions.
- An object above the camera is not displayed.
- The object displayed in the Front-view mode or the Rear-view mode may not be displayed in the Bird's eye-view mode.
- The view in the Bird's eye-view mode may be displaced from its true position when the mounting location and angle of each camera are changed.
- The lines on the road may appear to be displaced or bent at the joint of the views.

Cargo loads

E00609902713

Cargo loads precautions**⚠ CAUTION**

- Do not load cargo or luggage higher than the top of the seatback. Be sure that your cargo or luggage cannot move once your vehicle is moving. Having the driver's vision blocked, and your cargo being thrown inside the cabin if you suddenly have to brake can cause a serious accident or injury.
- Load heavy cargo or luggage in the front of the vehicle. If the load in the back of the vehicle is too heavy, steering may become unstable.

7**Loading a roof carrier****⚠ CAUTION**

- Use a roof carrier that properly fits your vehicle. Do not load luggage directly onto the roof. For installation, refer to the instruction manual accompanying the roof carrier.

Trailer towing

NOTE

- We recommend you to use a MITSUBISHI MOTORS GENUINE roof carrier, since the brackets to be used have a special shape. For details, we recommend you to consult a MITSUBISHI MOTORS Authorized Service Point.

Roof carrier precaution

7

CAUTION

- Make sure that the weight of the luggage does not exceed the allowable roof load. If the allowable roof load is exceeded, this may cause damage to the vehicle. The roof load is the total allowable load on the roof (the weight of the roof carrier plus the weight of luggage placed on the roof carrier). For the specific value, refer to “Maximum roof load” on page 12-05.

CAUTION

- When luggage is loaded onto the vehicle, please make sure to drive slowly and avoid excessive manoeuvres such as sudden braking or quick turning. In addition, place the luggage on the carrier so that its weight is distributed evenly with the heaviest items on the bottom. Do not load items that are wider than the roof carrier. The additional weight on the roof could raise the vehicle’s centre of gravity and affect vehicle handling characteristics. As a result, driving errors or emergency manoeuvres could lead to a loss of control and result in an accident.
- Before driving and after travelling a short distance, always check the load to make sure it is securely fastened to the roof carrier. Check periodically during your travel that the load remains secure.

NOTE

- To prevent wind noise or reduction in fuel economy, remove the roof carrier when not in use.
- Remove the roof carrier before using an automatic car wash.
- Be sure that adequate clearance is maintained for raising the sunroof (if so equipped) when installing a roof carrier.

NOTE

- Be sure that adequate clearance is maintained for raising the tailgate while loading luggage on the roof carrier.

Trailer towing

E00610001993

In order to tow a trailer with your vehicle, have a trailer towing device mounted that meets all relevant regulations in your area, consult a MITSUBISHI MOTORS Authorized Service Point.

The regulations concerning the towing of a trailer may differ from country to country. You are advised to obey the regulations in each area.

CAUTION

- Danger of Accident!
A towing bar should be fitted according to MITSUBISHI MOTORS guidelines.

Maximum towable weight with brake and maximum trailer-nose weight

Never exceed the maximum towable weight with brake and the maximum trailer-nose weight as listed in the specifications.

(Refer to page “Vehicle weight” on page 12-05.)

If you tow a trailer at an altitude of more than 1,000 m above sea-level, reduce your weight by 10 % of the gross combination weight for every increase of 1,000 m above sea-level, as the engine output is lowered owing to decrease in atmospheric pressure.

Towing bar mounting specifications

See the following table for fixing points (A) for the towing bar.

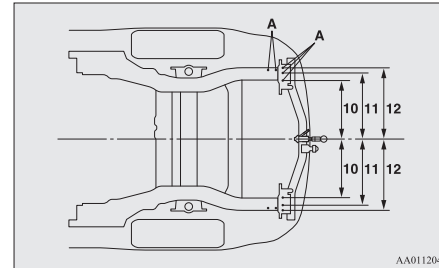
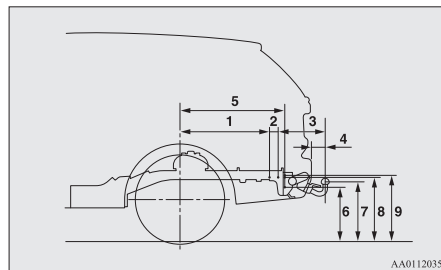

1	698 mm
2	69 mm
3	369 mm
4	101 mm
5	815 mm
6	448 mm (at kerb weight condition)
7	496 mm (at kerb weight condition) 384 - 397 mm (at laden condition)
8	534 mm (at kerb weight condition)
9	544 mm (at kerb weight condition)
10	473 mm
11	528 mm

12	583 mm
----	--------

Operating hints

- Be sure that the driving speed does not exceed 100 km/h (62 mph) for trailer operation. It is also recommended that you obey the local regulations in case driving speed with a trailer is limited to less than 100 km/h (62 mph).
- To prevent shocks from the overrun brake, depress the brake pedal lightly at first and then more strongly.

7

Overheating

This will normally occur as a result of some mechanical failure. If your vehicle should overheat, stop and check for a loose or broken water pump/alternator drive belt, a blocked radiator air intake or a low coolant level. If these items are satisfactory the overheating could be caused by a number of mechanical causes that would have to be checked at a competent service centre.

CAUTION

- If the engine overheats, reference should be made to “Engine overheating” section of “For emergencies” prior to taking any corrective action.

Trailer towing

Parking

It is not recommended to park on a steep slope while towing trailer.

If parking on a steep slope cannot be avoided, the road grade should be less than 12% and the following procedure performed.

1. Apply the parking brake firmly on the vehicle and the trailer (if fitted).
2. Put the select position in "P".
3. Place chocks or blocks at the tyres on both vehicle and trailer.
4. Turn the front wheels into the shoulder of the road to prevent the vehicle from moving.

7

Driving on long up hills while towing trailer

When the remaining quantity of the drive battery is low, or high-speed driving on long up hills at high temperature, the drive battery output is restricted and the vehicle speed may be decreased.

The vehicle speed may be recovered if the drive battery quantity is recovered.

NOTE

- In charge mode, if the remaining quantity of the drive battery can be increased in advance, it can prevent the vehicle speed from decreasing on long up hills. Refer to "Battery charge mode" on page 7-29.

For pleasant driving

Ventilators.....	8-02	Ashtray*.....	8-74
Automatic climate control air conditioner.....	8-06	Cigarette lighter*.....	8-75
Important operation tips for the air conditioner.....	8-14	Accessory socket*.....	8-75
Air purifier.....	8-15	220-240 V AC power supplies*.....	8-76
Remote Climate Control*.....	8-15	Interior lamps.....	8-79
Heating.....	8-15	Storage spaces.....	8-82
LW/MW/FM radio/CD player*.....	8-15	Cup holder.....	8-84
Handling of Discs.....	8-20	Bottle holder.....	8-84
Audio Files (MP3/WMA/AAC).....	8-21	Cargo area cover.....	8-85
Important Points on Safety for the Customer.....	8-25	Assist grips.....	8-86
Operation Keys.....	8-25	Coat hook.....	8-86
Listen to Radio.....	8-28	Luggage hooks.....	8-87
Listen to DAB*.....	8-29		
Listen to Traffic Messages.....	8-31		
Listen to CDs.....	8-31		
Listen to MP3s.....	8-32		
Listen to an iPod.....	8-33		
Listen to Audio Files on a USB Device.....	8-35		
To play iPod/USB memory device tracks via voice operation (vehicles with Bluetooth® 2.0 interface).....	8-37		
Listen to Bluetooth Audio*.....	8-40		
Display Indicator.....	8-43		
Audio Quality and Volume Balance Adjustment.....	8-44		
System Settings.....	8-45		
Troubleshooting.....	8-49		
Link System*.....	8-51		
Bluetooth® 2.0 interface*.....	8-51		
USB input terminal*.....	8-71		
Sun visors.....	8-73		

Ventilators

Ventilators

E00700102319

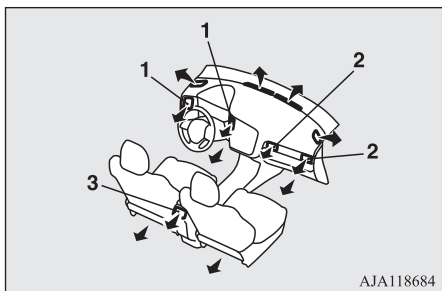

AJA118684

8

- 1- Driver's ventilators
- 2- Passenger's ventilators
- 3- Rear ventilators

NOTE

- Do not place beverages on top of the instrument panel. If they splash into the air conditioning ventilators, they could damage the system.

Air flow and direction adjustments

E00700202512

NOTE

- Be careful not to spill drinks, etc., into the ventilators. Doing so might cause the air conditioner not to function normally.

Driver's ventilators

Move the knob (A) to adjust the air flow direction.

To close the ventilator, fully move the knob (A) to the outer side.

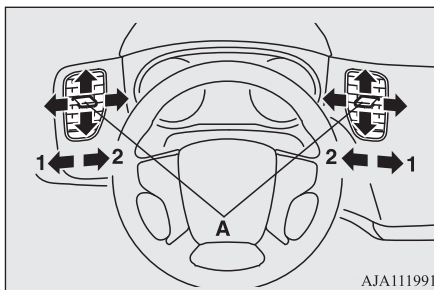

AJA111991

- 1- Close
- 2- Open

Passenger's ventilators

Move the knob (A) to adjust the air flow direction.

To close the ventilator, fully move the knob (A) to the left side.

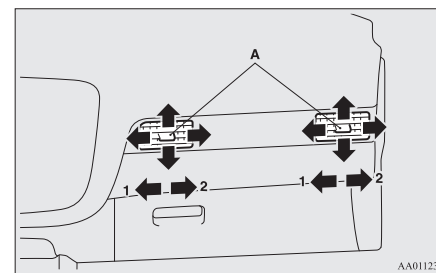

AA0112325

- 1- Close
- 2- Open

Rear ventilators

The ventilators can be opened and closed with the dial (A).

- ≡ - Open
- ☒ - Close

Adjust the direction of the air flow by moving the knob (B).

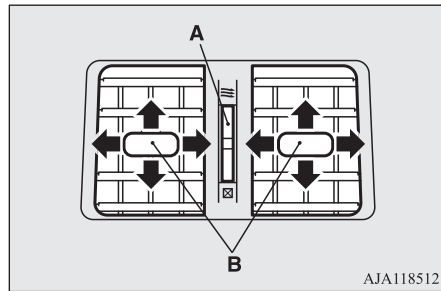

Ventilators

Changing the mode selection

E00700302917





The mode selection and air flowing from the ventilators

These symbols are used in the next several illustrations to demonstrate the quantity of air coming from the ventilators.

→: Small amount of air from the ventilators

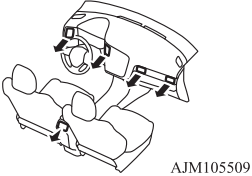
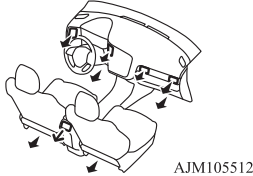
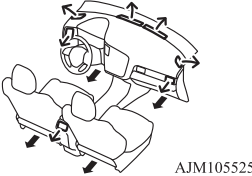

↗: Medium amount of air from the ventilators

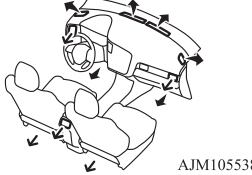
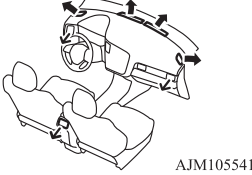
➔: Large amount of air from the ventilators

 Face position	 Foot/Face position	 Foot position
 AJM105509	 AJM105512	 AJM105525
 Foot/Demister position	 Demister position	
 AJM105538	 AJM105541	

8

 **NOTE**

- The foot/face air flow ratio can be adjusted with the mode selection in the “” position and the foot/demister air flow ratio can be adjusted with the mode selection in the “” position.
For further information, we recommend you to consult a MITSUBISHI MOTORS Authorized Service Point.
On vehicles equipped with the Smartphone Link Display Audio or the MITSUBISHI Multi-Communication System (MMCS), screen operations can be used to make the adjustment. Refer to the separate owner’s manual for details.

Automatic climate control air conditioner

Automatic climate control air conditioner

E00702402026

Cooling or heating can only be performed when ready indicator is illuminating. When the operation mode is ON, only the blower is available.

NOTE

- If the drive battery level display indicates 0, the cooling performance cannot be obtained even the air conditioner is turned on.
Refer to “Drive battery level display screen” on page 6-11.
- If the engine cannot be started due to fuel shortage, etc., the heating performance cannot be obtained even the air conditioner is turned on.
- While the drive battery is being charged, you can use the air conditioner.

8

Control panel

E00702502984

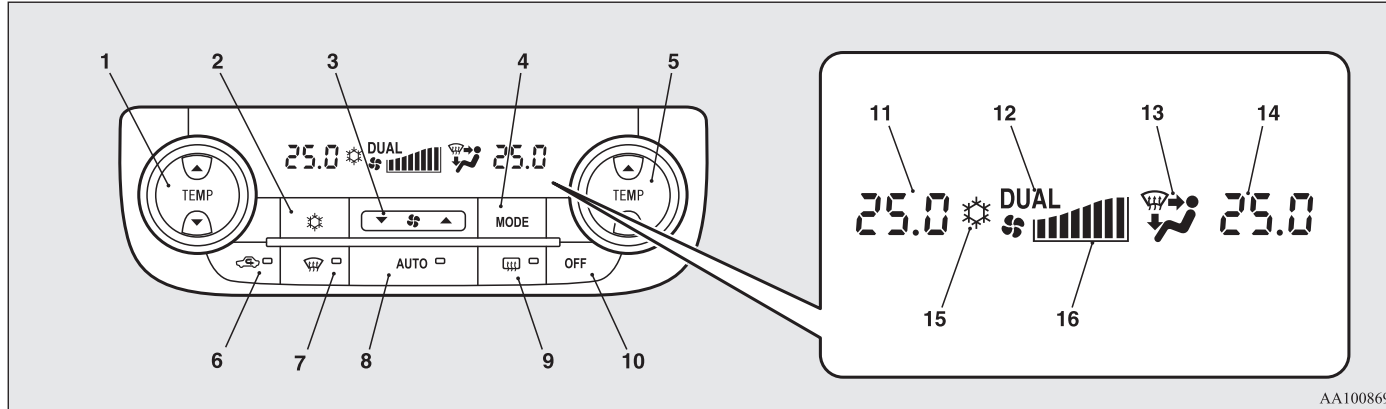

AA1008694

8-06 For pleasant driving

OGGE19E1

Automatic climate control air conditioner

- | | | |
|--|---|---|
| 1- Driver's side temperature control switch (LHD vehicles)
Passenger's side temperature control switch (RHD vehicles) | 6- Air selection switch
7- Demister switch
8- AUTO switch
9- Rear window demister switch → p. 6-74 | 13- Mode selection display |
| 2- Air conditioning switch | 10- OFF switch | 14- Passenger's side temperature display (LHD vehicles) → p. 8-09
Driver's side temperature display (RHD vehicles) → p. 8-09 |
| 3- Blower speed selection switch | 11- Driver's side temperature display (LHD vehicles) → p. 8-09
Passenger's side temperature display (RHD vehicles) → p. 8-09 | 15- Air conditioning indicator |
| 4- MODE switch | 12- DUAL indicator | 16- Blower speed display |
| 5- Passenger's side temperature control switch (LHD vehicles)
Driver's side temperature control switch (RHD vehicles) | | |

Automatic climate control air conditioner

NOTE

- There is an interior air temperature sensor (A) in the illustrated position.
Never place anything on top of the sensor, since doing so will prevent it from functioning properly.

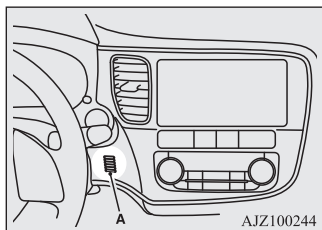

8

- While the EV priority mode is activated, except when pressing the demister switch, the engine does not start. Therefore, if your vehicle is not equipped with the electric heater, the heating performance cannot be obtained while the EV priority mode is activated. Also, if your vehicle is equipped with the electric heater, the heating performance may not be sufficiently obtained while the EV priority mode is activated. In such case, cancel the EV priority mode. Refer to “EV switch” on page 7-25.
- Since the air conditioning operation is controlled while the ECO mode is operating, you may feel that effectiveness of the air conditioner is weak. Also, on vehicles without electric heater, the heating performance cannot be obtained while the ECO mode is operating since engine starting is controlled. In such case, cancel ECO mode. Refer to “ECO mode switch” on page 6-68.
- Even if the ECO mode is operating, you can select normal operation of the air conditioner.
On vehicles equipped with the Smartphone Link Display Audio or the MITSUBISHI Multi-Communication System (MMCS), screen operations can be used to change the setting. Refer to the separate owner’s manual for details.
- In extreme cold, the air conditioning control panel screen may operate sluggishly. This does not indicate a problem.
It will disappear when the vehicle interior temperature rises to a normal temperature.

Blower speed selection switch

E00702801515

Press ▲ of the blower speed selection switch to increase the blower speed.

Press ▼ of the blower speed selection switch to decrease the blower speed.

8-08 For pleasant driving

OGGE19E1

The selected blower speed (A) will be shown in the display.

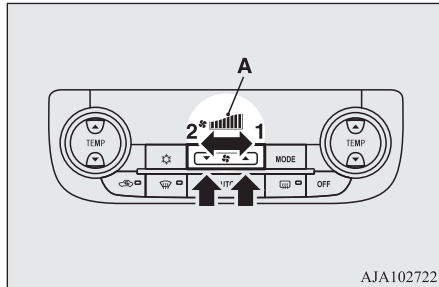

AJA102722

- 1- Increase
- 2- Decrease

Temperature control switch

E00703001963

Press ▲ or ▼ of the temperature control switch to the desired temperature.

The selected temperature (A) will be shown in the display.

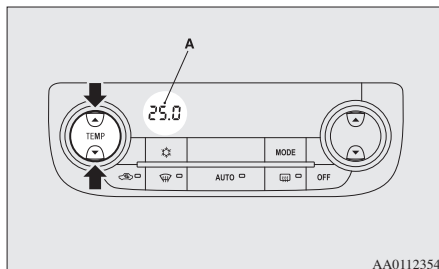

AA0112354

NOTE

- The temperature value of air conditioning is switched in conjunction with outside temperature display unit of the multi information display. Refer to “Changing the temperature unit” on page 6-20.
- While the engine coolant temperature is low, the temperature of the air from the heater will not change instantly, even if you have selected warm air with the switch. To prevent the windscreen and windows from fogging up, the ventilator mode will be changed to “” and the blower speed will be reduced while the system is operating in the AUTO mode.
- When you feel that it is hot or cold to the setting temperature, it is possible to adjust so that you can feel more comfortable. For further information, we recommend you to consult a MITSUBISHI MOTORS Authorized Service Point.
- When the temperature is set to the highest or the lowest, the air selection and the air conditioning will be automatically changed as follows. Also, if the air selection is operated manually after an automatic takeover, manual operation will be selected.
 - Quick Heating (When the temperature is set to the highest setting)
Outside air will be introduced and the air conditioner will stop.

NOTE

- Quick Cooling (When the temperature is set to the lowest setting)
Inside air will be recirculated and the air conditioner will operate.
- When the air conditioner is set to quick heating, the engine starts running (except vehicles with electric heater).

The settings described above are the factory settings.

The air selection and air conditioning switches can be customized (function setting changed), and the automatic switching of outside air and the air conditioner according to operating conditions can be changed as desired.

For further information, we recommend you to consult a MITSUBISHI MOTORS Authorized Service Point.

Refer to “Customizing the air conditioning switch” on page 8-11.

Refer to “Customizing the air selection” on page 8-10.

Automatic climate control air conditioner

Synchronized mode and dual mode

The driver's side and the passenger's side temperature can be controlled independently. At this time, the "DUAL" indicator (A) will be shown in the display.

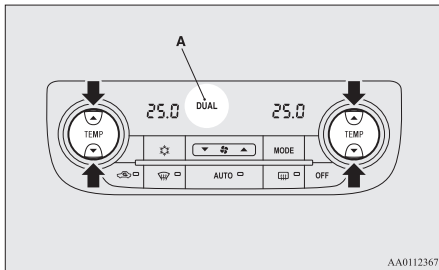

● Synchronized mode

If the driver's side temperature control switch is pressed, the passenger's side temperature will also be controlled to the same setting temperature as the driver's side.

● Dual mode

If the passenger's side temperature control switch is pressed under synchronized mode, the system will switch to dual mode. In dual mode, the driver's side and the passenger's side temperature can be set separately by using each temperature control switch.

Press the AUTO switch to return to synchronized mode.

8-10 For pleasant driving

Air selection switch

E00703401808

To change the air selection, simply press the air selection switch.

- Outside air: Indication lamp (A) is OFF
Outside air is introduced into the passenger compartment.
- Recirculated air: Indication lamp (A) is ON
Air is recirculated inside the passenger compartment.

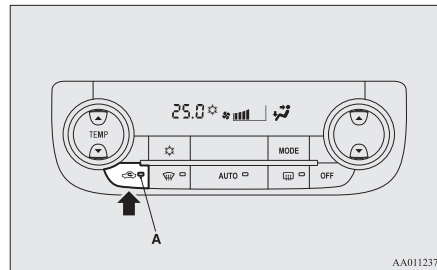

CAUTION

- Use of the recirculation position for extended time may cause the windows to fog up.

NOTE

- Normally, use the outside position to keep the windscreen and side windows clear and quickly remove fog or frost from the windscreen.
If high cooling performance is desired, or if the outside air is dusty or otherwise contaminated use the recirculation position. Switch to the outside position periodically to increase ventilation so that the windows do not become fogged up.
- When the engine coolant temperature rises to a certain level, the air selection is automatically switched to the recirculation position and the indication lamp (A) comes on. At this time, the system will not switch to the outside position even if the air selection switch is pushed.
- When the outside air temperature is high, the system will not switch to the outside position even if the air selection switch is pressed or the air conditioner is operating. This is to protect the air conditioner compressor and is not a failure.

Customizing the air selection

E00739600136

Functions can be changed as desired, as stated below.

- Enable automatic air selection control
When the AUTO switch is pressed, the air selection switch is also controlled automatically.

- Disable automatic air selection control
Even when the AUTO switch is pressed, the air selection switch is not controlled automatically.
- Setting change method
Hold down the air selection switch for approximately 10 seconds or more.
 - When the setting is changed from enable to disable
3 sounds are emitted and the indication lamp flashes 3 times.
 - When the setting is changed from disable to enable
2 sounds are emitted and the indication lamp flashes 3 times.

On vehicles equipped with the Smartphone Link Display Audio or the MITSUBISHI Multi-Communication System (MMCS), screen operations can also be used to change the setting. Refer to the separate owner's manual for details.

NOTE

- The factory setting is "Enable automatic air selection control".
- When the demister switch is pressed, in order to prevent misting of the windows the ventilator automatically switches to outside air even if "Disable automatic air selection control" is set.

AUTO switch

E00702601047

When the AUTO switch is pressed, the indication lamp (A) comes on and the mode selection, blower speed adjustment, recirculated/outside air selection, temperature adjustment, and air conditioner ON/OFF status are all controlled automatically.

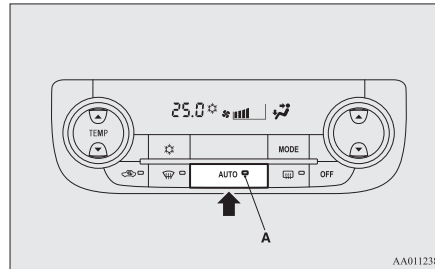

AA0112383

Automatic climate control air conditioner

Air conditioning switch

E00703502675

Push the switch to turn the air conditioner on, the "⚙️" indicator (A) will be shown in the display.

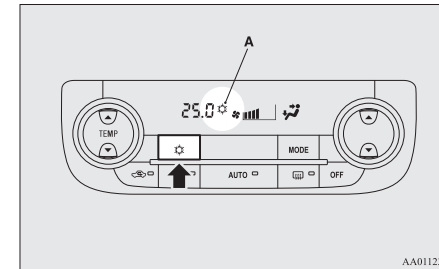

AA0112396

8

Push the switch again to switch it off.

NOTE

- If a problem is detected in the air conditioning system, the "⚙️" indicator blinks. Press the air conditioning switch once to turn it off, then once more to turn it back on. If the "⚙️" indicator does not blink for a while, there is nothing wrong. If it starts to blink again, we recommend you to have it checked.

Customizing the air conditioning switch

E00739700137

Functions can be changed as desired, as stated below.

For pleasant driving 8-11

Automatic climate control air conditioner

- Enable automatic air conditioning control



When the AUTO switch is pressed, or the temperature control switch is set to the minimum temperature, the air conditioning switch is controlled automatically.

- Disable automatic air conditioning control

The air conditioning switch is not controlled automatically as long as the air conditioning switch is not operated.

- Setting change method

Hold down the air conditioning switch for approximately 10 seconds or more.

- When the setting is changed from enable to disable
3 sounds are emitted and the “” indicator flashes 3 times.
- When the setting is changed from disable to enable
2 sounds are emitted and the “” indicator flashes 3 times.

On vehicles equipped with the Smartphone Link Display Audio or the MITSUBISHI Multi-Communication System (MMCS), screen operations can also be used to change the setting. Refer to the separate owner's manual for details.

NOTE

- The factory setting is “Enable automatic air conditioning control”.
- When the demister switch is pressed, in order to prevent misting of the windows the air conditioner operates automatically even if “Disable automatic air conditioning control” is set.



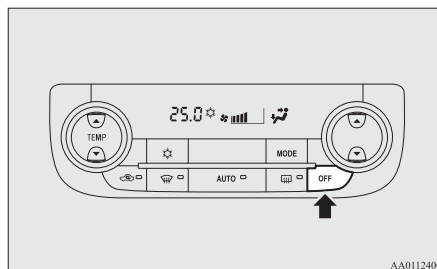

OFF switch

Push the OFF switch to turn off the air conditioning system.



MODE switch

E00703301227

Each time the MODE switch is pressed, the mode changes to the next one in the following sequence: “” → “” → “” → “”. The selected mode (A) is shown in the display. (Refer to “Changing the mode selection” on page 8-04.)

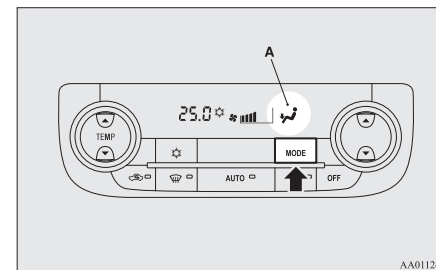

Demister switch

E00703901340

When this switch is pressed, the mode changes to the “” mode. The indication lamp (A) will come on. The selected mode (B) is shown in the display. (Refer to “Changing the mode selection” on page 8-04.)

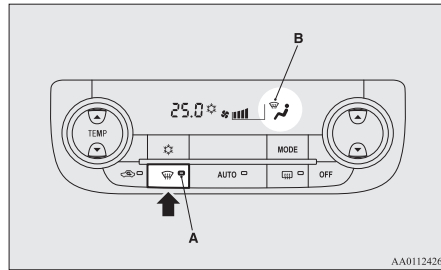

AA0112426

NOTE

- When the demister switch is pressed, the air conditioning system automatically operates and outside air (as opposed to recirculated air) is selected. This automatic switching control is carried out to prevent misting of the windows even if “Disable automatic air conditioning control” or “Disable automatic air selection control” is set. (Refer to “Customizing the air conditioning switch” on page 8-11, “Customizing the air selection” on page 8-10.)

NOTE

- To ensure a clear view, the engine may start when the demister switch is pressed even while the EV priority mode is activated. Refer to “EV switch” on page 7-25.

Operating the system in automatic mode

E00704102649

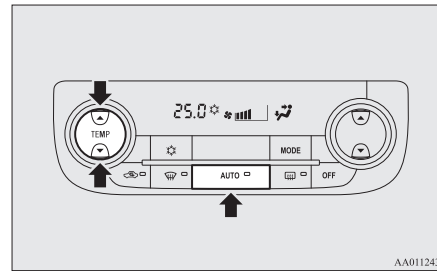

AA0112439

In normal conditions, use the system in the AUTO mode and follow these procedures:

1. Push the AUTO switch.
2. Set the temperature control switch to the desired temperature.

The mode selection, blower speed adjustment, recirculated/outside air selection, temperature adjustment, and air conditioner ON/OFF status are all controlled automatically.

NOTE

- If the blower speed selection switch, air conditioning switch, MODE switch, or air selection switch is operated while the system is operating in the AUTO mode, the activated function overrides the corresponding function of automatic control. All other functions remain under automatic control.

Operating the system in manual mode

E00704201308

8

Blower speed and ventilator mode will be controlled manually by setting the blower speed selection switch and the MODE switch to the desired positions.

To return to automatic operation, press the AUTO switch.

Demisting of the windscreen and door windows

E00704302016

CAUTION

- For safety, make sure you have a clear view through all the windows.

Important operation tips for the air conditioner

For ordinary demisting

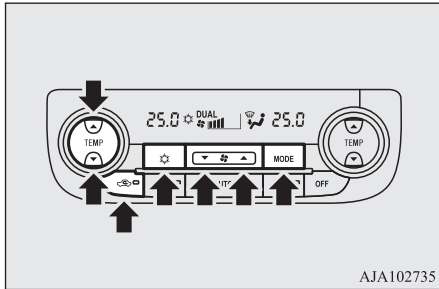

8

1. Set the air selection switch to the outside position.
2. Set the MODE switch to the “OFF” position.
3. Select your desired blower speed by pressing the blower speed selection switch.
4. Select your desired temperature by pressing the temperature control switch.
5. Push the air conditioning switch.

For quick demisting

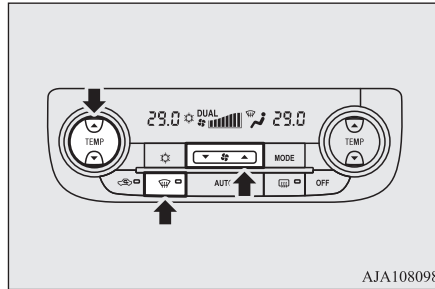

1. Push the demister switch to change to the “OFF” position.
2. Set the blower to the maximum speed.
3. Set the temperature to the highest position.

NOTE

- To demist effectively, direct the air flow from the side ventilators towards the door windows.
- Do not set the temperature to the max. cool position. Cool air will blow against the window glasses and prevent demisting.

Important operation tips for the air conditioner

E00708302388

- Park the vehicle in the shade. Parking in the hot sun will make the vehicle inside extremely hot, and it will require more time to cool the interior. If it is necessary to park in the sun, open the windows for the first few minutes of air conditioning operation to expel the hot air.
- Close the windows when the air conditioner is in use. The entry of outside air through open windows will reduce the cooling efficiency.
- Too much cooling is not good for the health. Keep the difference between the vehicle interior temperature and outside temperature at 5 to 6 °C.
- When operating the system, make sure the air intake, which is located in front of the windscreen, is free of obstructions such as leaves and snow. Leaves collected in the air-intake plenum may reduce air flow and plug the plenum water drains.
- Too much cooling/heating can affect the EV cruising range, so maintain an appropriate temperature to extend the EV cruising range.

Air conditioning system refrigerant and lubricant recommendations

If the air conditioner seems less effective than usual, the cause might be a refrigerant leak.

We recommend you to have the system inspected.

[Except for vehicles for Ukraine]

The air conditioning system in your vehicle must be charged with the refrigerant HFO-1234yf and the lubricant POE MA68EV.

[Vehicles for Ukraine]

The air conditioning system in your vehicle must be charged with the refrigerant HFC-134a and the lubricant POE MA68EV.

Use of any other refrigerant or lubricant will cause severe damage which will result in the need to replace your vehicle's entire air conditioning system. The release of refrigerant into the atmosphere is not recommended.

We recommend you to recover and recycle the refrigerant for reuse.

During a long period of disuse

The air conditioner should be operated for at least five minutes each week, even in cold weather. This is to prevent the compressor from seizing and to maintain the air conditioner in the best operating condition.

Air purifier

E00708400718

An air filter has been incorporated into this air conditioner so that dirt and dust are cleaned from the air.

Replace the air filter periodically as its ability to clean the air will be reduced as it collects pollen and dirt. For the maintenance interval, refer to the "SERVICE BOOKLET".

NOTE

- Operation in certain conditions such as driving on a dusty road and frequent use of the air conditioner can lead to reduction of service life of the filter. When you feel that the air flow is lower than normal or when the windscreen or windows start to fog up easily, replace the air filter.
We recommend you to have it checked.

Remote Climate Control*

E00735401087

You can run the air conditioner in advance of using the vehicle.

For details, refer to "MITSUBISHI Remote control: Remote Climate Control" on page 3-20.

Heating

E00733901062

When heating, the engine starts running because the heating system uses the heat of engine coolant.

On vehicles with electric heater, it can decrease the number of times engine starting because electrical power stored in the drive battery is also used when heating.

NOTE

- If you want to stop the engine running for heating, select the EV priority mode before operating the air conditioner. Refer to "EV switch" on page 7-25.

LW/MW/FM radio/CD player*

E00708503387

The audio system can only be used when the operation mode of the power switch is in ON or ACC.

 **NOTE**

- To listen to the audio system while the Plug-in Hybrid EV system is not operating, put the operation mode of the power switch in ACC.
If the operation mode of the power switch is left in ACC, the accessory power will automatically turn off after a certain period of time and you will no longer be able to use the audio system. The accessory power comes on again if the operation mode of the power switch is operated with is in the ACC. Refer to “ACC power auto-cutout function” on page 7-13.
- If a cellular phone is used inside the vehicle, it may create noise from the audio equipment. This does not mean that anything is wrong with your audio equipment. In such a case, use the cellular phone at a place as far away as possible from the audio equipment.
- If foreign objects or water get into the audio equipment, or if smoke or a strange odour comes from it, immediately turn off the audio system. We recommend you to have it checked. Never try to repair it by yourself. Avoid continuous usage without inspection by a qualified person.

8

Important Points on Usage

E00735500023

iPod/iPhone Playback Function*

- This product supports audio playback from iPod/iPhone devices, however differing versions mean that playback cannot be guaranteed.
- Please be aware that depending on the iPod/iPhone model or version, operation may differ.

How to Clean

E00735700025

- If the product becomes dirty, wipe with a soft cloth.
- If very dirty, use a soft cloth dipped in neutral detergent diluted in water, and then wrung out. Do not use benzene, thinners, or other chemical wipes. This may harm the surface.

Trademarks

E00735801238

- Product names and other proper names are the trademarks or registered trademarks of their respective owners.
- Furthermore, even if there is no specific denotation of trademarks or registered trademarks, these are to be observed in their entirety.

Made for



iPod



iPhone

“Made for iPod”, “Made for iPhone” mean that an electronic accessory has been designed to connect specifically to iPod or iPhone, respectively, and has been certified by the developer to meet Apple performance standards. iPhone, iPod, iPod classic, iPod nano, and iPod touch are trademarks of Apple Inc., registered in the U.S. and other countries.

Apple is not responsible for the operation of this device or its compliance with safety and regulatory standards.

 **NOTE**











- iPod and iTunes licensing allows individual users to privately reproduce and play back non-copyrighted material as well as material that may be legally copied and reproduced. Infringement of copyright is prohibited.

 **NOTE**

- For vehicles with a Bluetooth® 2.0 interface, the types of devices that can be connected may vary.
For details, access the MITSUBISHI MOTORS website.
Please read and agree to the “Warning about Links to the Web Sites of Other Companies”. The websites mentioned above may connect you to websites other than the MITSUBISHI MOTORS website.
<http://www.mitsubishi-motors.com/en/products/index.html>

LW/MW/FM radio/CD player*

8

iPod		iPod classic		
 iPod 5th generation (video) 60GB 80GB	 iPod 5th generation (video) 30GB	 iPod classic 160GB (2009)	 iPod classic 160GB (2007)	 iPod classic 80GB
iPod nano				
 iPod nano 6th generation 8GB 16GB	 iPod nano 5th generation (video camera) 8GB 16GB	 iPod nano 4th generation (video) 8GB 16GB		
 iPod nano 3rd generation (video) 4GB 8GB	 iPod nano 2nd generation (aluminium) 2GB 4GB 8GB	 iPod nano 1st generation (aluminium) 1GB 2GB 4GB		

AA5013326

LW/MW/FM radio/CD player*

iPod touch



iPod touch
4th generation
8GB 32GB 64GB



iPod touch
3rd generation
32GB 64GB



iPod touch
2nd generation
8GB 16GB 32GB



iPod touch
1st generation
8GB 16GB 32GB

iPhone



iPhone 4S
16GB 32GB 64GB



iPhone 4
16GB 32GB



iPhone 3GS
8GB 16GB 32GB



iPhone 3G
8GB 16GB

8

AJ5100128

Handling of Discs

Handling of Discs

E00735901040

This explains care that should be taken in the handling of discs.

Important Points on Handling

- Fingerprints or other marks on the read surface of the disc may result in its content being more difficult to read. When holding the disc, grip both edges, or one edge and the centre hole, in order that the read surface is not touched.
- Do not affix paper or stickers, or otherwise damage the disc.
- Do not forcefully insert a disc if another is already within the device. This can result in damage to discs, or malfunction.

Cleaning

- Periodically clean the read surface of the disc. When cleaning, do not wipe in a circular motion. Instead, wipe gently outwards from the centre of the disc to the outer edge.
- New discs may have burring around the outer edge or in the hole in the centre. Ensure you check for these. If there are burrs, these may lead to faulty operation, therefore ensure these are removed.

8-20 For pleasant driving

Important Points on Storage

- When not using discs, ensure these are kept in cases, and stored out of direct sunlight.
- If discs are not going to be used for a long period of time, remove these from the product.

Disc Playback Environment

In cold environments such as in mid-winter when the interior of the vehicle is cold, turning the heater on and immediately trying to use the product may cause condensation (water droplets) to form on the disc and internal optical components, and this may prevent the product from operating correctly. In these conditions, remove the disc, and wait a short time before use.

Copyright





Actions such as unauthorized reproduction, broadcast, public performance, or rental of discs that comprise other than personal use are prohibited by law.

Types of Disc That Can Be Played Back

E00736001035

The following marks are printed on the disc label, package, or jacket.

OGGE19E1

Type	Size	Maximum playback time	Comments
CD-DA 	12 cm	74 minutes	—
CD-TEXT 	12 cm	74 minutes	—
CD-R/RW  	12 cm	—	•Disc containing MP3 files

Discs That May Not Be Played Back

- Playback of discs other than those described in “Types of Disc That Can Be Played Back” is not guaranteed.
- 8 cm discs may not be used.

Audio Files (MP3/WMA/AAC)

- Do not insert irregularly-shaped discs (for example, heart-shaped), as these may result in malfunction. Additionally, discs that have transparent portions may not be played back.
 - Discs that have not been finalized cannot be played back.
 - Even if recorded using the correct format on a recorder or computer, application software settings and environments; disc peculiarities, damage, or marking; or dirt or condensation on the lens inside the product may render the disc unplayable.
 - Depending on the disc, some functions may not be used, or the disc may not play back.
 - Do not use discs with cracks or warps.
 - If the disc has stickers affixed, remains from removed stickers, or affixed adhesive, then do not use the disc.
 - Discs that have decorative labels or stickers may not be used.
- Playback of other than standard CDs is not guaranteed. Even if the audio can be played back, the audio quality cannot be guaranteed.
 - When playing back other than standard CDs, the following may occur.
 - There may be noise during playback.
 - There may be jumping in the audio.
 - The disc may not be recognized.
 - The first track may not be played back.
 - It may take longer than usual until start of playback of tracks.
 - Playback may start from within the track.
 - Some parts may not be played back.
 - Tracks may freeze during playback.
 - Tracks may be displayed erroneously.

Audio Files (MP3/WMA/AAC)

E00736100026

This product can play back MP3/WMA/AAC format audio files recorded on CD-ROM, CD-R/RW, and USB devices.

There are limitations on the files and media that can be used, therefore read the following prior to recording MP3/WMA/AAC format audio files on discs or USB devices.

Additionally, ensure you read the user manuals for your CD-R/RW drive and the writing software, and ensure these are used correctly. If the MP3/WMA/AAC format audio files includes title information or other data, then this can be displayed.

CAUTION

- CD-ROM and CD-R/RW media can only play back MP3 format audio files.
- Actions such as copying audio CDs or files and either distributing these to others for free or for charge, or uploading files via the Internet or other means to servers is an infringement of the law.
- Do not append the file extensions “.mp3”, “.wma”, or “.m4a”, to other than MP3/WMA/AAC format files. Playing back discs with these types of files recorded upon them may cause the files to be incorrectly identified for playback, which may lead to loud noise, resulting in speaker damage or accident.

NOTE

- Depending on the condition of the disc recorder or recording software used, correct playback may not be possible. In these cases, refer to the user manual for your product or software.

Nonstandard CDs

This product will play back audio CDs, however please be aware of the following points regarding CD standards.

- Ensure that you use discs with  on the label surface.

Audio Files (MP3/WMA/AAC)

NOTE

- Depending on your computer's operating system, version, software, or settings, files may not have a file extension appended. In these cases, append the file extensions ".mp3", ".wma", or ".m4a" when copying the files.
- Files larger than 2GB in size cannot be played back.

Data Formats That Can Be Played Back

Data formats that can be played on discs (CD-ROM, CDR/RW) and USB devices differ.

Data format	DISC	USB device
MP3	○	○
WMA	X	○
AAC	X	○

Folder Structure

Up to 8 folder levels can be recognized.

You can create a folder structure as in Genre - Artist - Album - Track (MP3/WMA/AAC format audio files) for management of tracks.

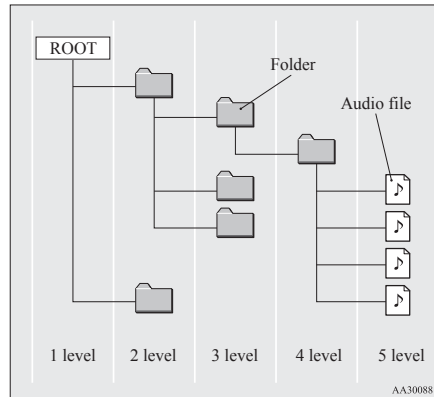

Name	Specification	Explanation	
Format specifications	ISO9660	Level 1	Maximum 8 character file name, and 3 character file extension. (single-byte alphanumeric capital letters, numerals, “_” may be used)

Name	Specification	Explanation	
Format specifications	ISO9660 extension	Joliet	Files names up to a maximum 64 characters can be used.
Multisession	Not supported (only first session supported)		
Maximum number of levels	8 levels (if the root is the 1 st level)		
Maximum folder number	700 folders (including root)		
Maximum file number*1	65,535 files (total number on media. Other than MP3, WMA, and AAC files not included)		
File name and folder name restrictions	Maximum 64 bytes (for Unicode, 32 characters), files/folders with file/folder names longer than this will not be displayed or played back.		
USB supported formats	The recommended file system is FAT32. 1 partition only		

*1: Do not include other than MP3/WMA/AAC files. However, if storing many tracks within the same folder, these may not be recognized even if less than the maximum number of tracks. In these cases, divide the tracks up into multiple folders.

NOTE

- The order in which folders and audio files are displayed on this product may be different to how they are displayed on a computer.

What Is MP3?

E00736400029
MP3 is the abbreviation of “MPEG-1 Audio Layer 3”. MPEG is an abbreviation of “Motion Picture Experts Group”, and this is a video compression standard used in video CDs, etc.

MP3 is one of the audio compression methods contained in the MPEG audio standard, and reduces the quality of sounds that are beyond the auditory resolution of the human ear and that are hidden by louder sounds, thus creating high-quality data with a lower data size.

This can compress CD audio to approximately 1/10 its original data size without perceptible loss, approximately 10 CDs can be written to a single CD-R/RW disc.

CAUTION

- MP3 files different to the standards at right may not play back correctly, or file/folder names may not be displayed correctly.

Standards for MP3 Files That Can Be Played Back

Specifications for MP3 files that can be played are as shown below.

Item	Details
Specification	MPEG-1 AUDIO LAYER3
	MPEG-2 AUDIO LAYER3
Sampling frequency [kHz]	MPEG-1: 32/44.1/48
	MPEG-2: 16/22.05/24
Bit rate [kbps]	MPEG-1: 32 to 320
	MPEG-2: 8 to 160
VBR (variable bit rate)	Support
Channel mode	Stereo/ Joint stereo/ Dual channel/ Monaural
File extension	mp3

Item	Details
Supported tag information	ID3 tag Ver. 1.0, Ver. 1.1, Ver. 2.2, Ver. 2.3, Ver. 2.4 (ISO-8859-1, UTF-16 (Unicode)), Titles, Artist name, Album name
Maximum number of characters that can be indicated on the display	64 characters

What Is WMA?

E00736601031
WMA is the abbreviation of Windows Media Audio, and this is an audio compression format from Microsoft. This is a compression format that has a higher compression ratio than MP3.

NOTE

- Microsoft, Windows Media, and Windows are registered trademarks of Microsoft Corporation (USA) and in other countries.

CAUTION

- WMA supports digital rights management (DRM). This product cannot play back WMA files protected using this system.

Audio Files (MP3/WMA/AAC)

⚠ CAUTION

- WMA files different to the standards at right may not play back correctly, or file/folder names may not be displayed correctly.
- “Pro”, “Lossless”, and “Voice” are not supported.

Standards for WMA Files That Can Be Played Back

Specifications for WMA files that can be played are as shown below.

8

Item	Details
Specification	Windows Media Audio Version 7.0/8.0/9.0
Sampling frequency [kHz]	32/44.1/48
Bit rate [kbps]	48 to 320
VBR (variable bit rate)	Support
Channel mode	Stereo/Monaural
File extension	wma
Supported tag information	WMA tags Title name, Artist name, Album name

8-24 For pleasant driving

Item	Details
Maximum number of characters that can be indicated on the display	64 characters

What is AAC?

E00736801033

AAC is the abbreviation of Advanced Audio Coding, and this is an audio compression standard used in “MPEG-2” and “MPEG-4”. This features 1.4x the compression of MP3, with comparable audio quality.

⚠ CAUTION

- AAC supports digital rights management (DRM). This product cannot play back AAC files protected using this system.
- AAC files different to the standards at right may not play back correctly, or file/folder names may not be displayed correctly.

Standards for AAC Files That Can Be Played Back

Specifications for AAC files that can be played are as shown below.

Item	Details	
Specification	Advanced Audio Coding MPEG4/AAC-LC MPEG2/AAC-LC	
Sampling frequency [kHz]	MPEG4	8/11.025/12/16/22.05/24/32/44.1/48
	MPEG2	8/11.025/12/16/22.05/24/32/44.1/48
Bit rate [kbps]	MPEG4	8 to 320
	MPEG2	8 to 320
VBR (variable bit rate)	Support	
Channel mode	Stereo/Monaural	
File extension	m4a	
Supported tag information	AAC tags or ID3 tags Title, Artist name, Album name	
Maximum number of characters that can be indicated on the display	64 characters	

OGGE19E1

Important Points on Safety for the Customer

E0073700035

This product features a number of pictorial indications as well as points concerning handling so that you can use the product correctly and in a safe manner, as well as prevent injury or damage to yourself, other users, or property.

WARNING

- The driver should not pay close attention to the display while driving. This may prevent the driver looking where they are going, and cause an accident.
- The driver should not perform complicated operations while driving. Performing complicated operations while driving may prevent the driver looking where they are going, and cause an accident. Therefore stop the vehicle in a safe location before performing such operations.
- Do not use during malfunctions, such as when no sound is audible. This may lead to accident, fire, or electric shock.
- Ensure water or other foreign objects do not enter the product. This may lead to smoking, fire, electric shock, or malfunction.

WARNING

- Do not insert foreign objects into the disc slot. This may lead to fire, electric shock, or malfunction.
- In the event of abnormalities occurring when foreign objects or water enter the product, resulting in smoke or a strange smell, immediately stop using the product, and consult a MITSUBISHI MOTORS Authorized Service Point. Continuing to use the product may result in accident, fire, or electric shock.
- Do not disassemble or modify the product. This may lead to malfunction, fire, or electric shock.
- During thunderstorms, do not touch the antenna or the front panel. This may lead to electrical shock from lightning.

CAUTION

- Do not block ventilation holes or heat sinks on the product. Blocking ventilation holes or heat sinks may prevent heat from escaping from within the product, leading to fire or malfunction.

CAUTION

- Do not turn the volume up to the extent that you cannot hear sounds from outside the vehicle while driving. Driving without being able to hear sounds from outside the vehicle may result in an accident.
- Do not insert your hand or fingers into the disc slot. This may result in injury.

Operation Keys

E00737100023

8

Turn the Power ON/ OFF

E00737201089

1. Press the PWR/VOL key.

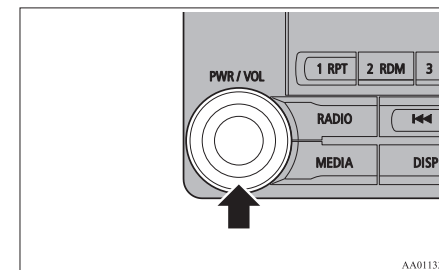

Turn the power on, and resume playback from the previous status.

Operation Keys

2. Press the PWR/VOL key.
Turn the power OFF.

NOTE

- Hold down the steering SOURCE button to also turn the audio function ON/OFF.

Adjust Volume

1. Turn the PWR/VOL key to adjust the volume.

8

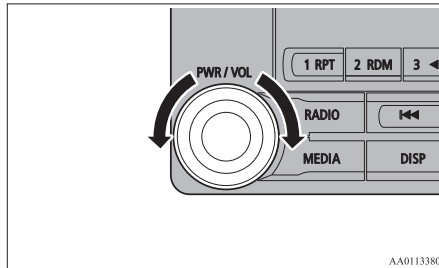

Turn the PWR/VOL key clockwise to increase, and counter-clockwise to decrease the volume.

NOTE

- The maximum value for volume is 45, and the minimum is 0.

8-26 For pleasant driving

NOTE

- The initial setting for volume is “17”.

Insert/Eject Discs

1. Insert the disc into the disc slot with the label surface up.

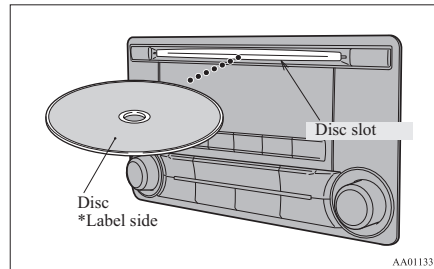

Push the disc in a certain amount, and the product will pull the disc in, and playback will start.

2. Press the ▲ key.
This will eject the disc from the product, so remove the disc.

CAUTION

- When replacing discs, first ensure that the vehicle is stopped in an area in which stopping is permitted.
- Do not insert your hand, fingers, or foreign objects into the disc slot. This may lead to injury, smoking, or fire.
- 8 cm CDs are not supported.

Explanation of Buttons

E00737501255

This explains names and functions of each part.

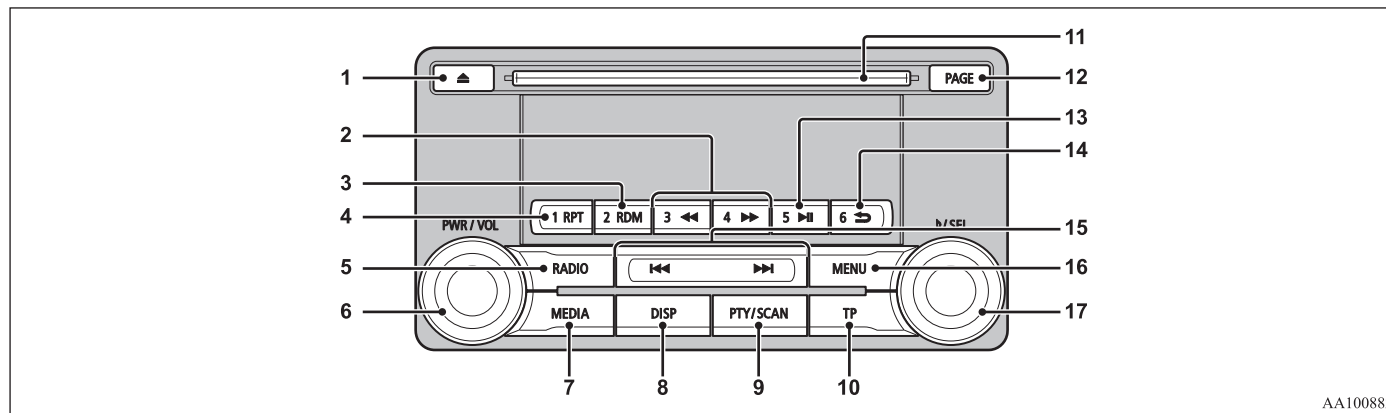

8

AA1008825

- | | | |
|---|--|--|
| <p>1- ▲ key
Use to eject a disc.</p> <p>2- 3◀◀ key/4▶▶ key
For audio, rewind/fast forward.
For radio, use as preset keys 3 and 4.</p> <p>3- 2RDM key
For audio, play random playback; for radio, use as preset key 2.</p> <p>4- 1RPT key
For audio, play repeat playback; for radio, use as preset key 1.</p> | <p>5- RADIO key
Switch the radio and the band.</p> <p>6- PWR/VOL key
Adjust the volume, and turn the power ON/OFF.</p> <p>7- MEDIA key
Switch between CD and other sources.</p> <p>8- DISP key
Switch the content of the display.</p> <p>9- PTY/SCAN key
For audio, play scan playback; for radio, search PTY.</p> | <p>10- TP key
Receive traffic messages.</p> <p>11- Disc slot</p> <p>12- PAGE key
Display indicator page advance.</p> <p>13- 5▶▶ key
Play/Pause Bluetooth Audio*, and use as preset key 5 for radio.</p> <p>14- 6↻ key
Return during audio track search, and stop Bluetooth Audio*.
For radio, use as preset key 6.</p> |
|---|--|--|

*Requires a separately-purchased Bluetooth- capable audio device in equipment by type (vehicles with a Bluetooth® 2.0 interface).

Listen to Radio

15- ◀ key/▶ key

For audio, select audio track/file; for radio, perform automatic station selection or ensemble/service station selection.

16- MENU key

Switch to Menu mode.

17- ▶/SEL key

Adjust audio quality and select items.
For radio, manually select stations.

Steering wheel audio remote control switches

E00737601517

8

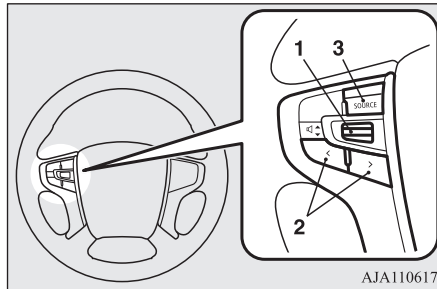

AJA110617

1- Volume up/down switch

Adjust audio functions and the mobile phone function volume.

2- < button, > button

Select CD and other audio source tracks and radio stations.

Hold down to skip up and down through tracks.

3- SOURCE button

Hold down to turn the audio function ON/OFF. Additionally, each time this is pressed, this switches the audio source. The order of switching is as shown below.

If devices are not connected, then these are to be skipped, and the next source selected.

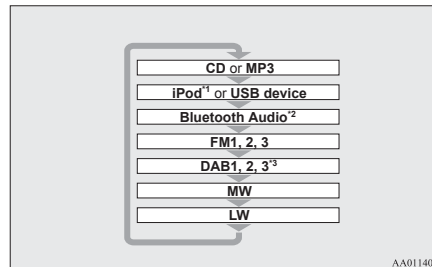

AA0114084

*1: An iPod cable (available separately) is required.

*2: Requires a separately-purchased Bluetooth-capable audio device (vehicles with a Bluetooth® 2.0 interface).

*3: Requires DAB tuner connection.

Listen to Radio

E00737700032

This explains how to listen to FM, MW, and LW radio broadcasts.

To Listen to the Radio

Press the RADIO key to switch the band.

Switch between FM1, FM2, FM3, MW, and LW bands.

The selected band is indicated on the display.

NOTE

- This switches in the order FM1, FM2, FM3, DAB1*, DAB2*, DAB3*, MW, and LW.
*:When a DAB tuner is connected.

Manual/Seek Station Selection

Turn the ▶/SEL key to the frequency to listen to.

8-28 For pleasant driving

OGGE19E1

Listen to DAB*

/SEL key (counter-clockwise)	Reduces the frequency being received.
/SEL key (clockwise)	Increases the frequency being received.
key (hold down)	Release the button to start seek station selection, and when a station is received, scanning stops.
key (hold down)	

Preset Memory

Register the broadcast station in advance, and select this at a later time.

1. Tune in to the frequency to register.
2. Hold down any of the keys from the IRPT key to the 6 key.

A “Beep” sounds, and the preset key is registered.

NOTE

- The preset memory can register a maximum of 6 stations for each band (FM1, FM2, FM3).
- If a preset key that already has a station registered is selected, then this is overwritten with the new preset.

NOTE

- Pressing the preset key will select the previously registered frequency.

Auto Memory (Auto Store)

The top 6 stations with a strong signal can be automatically registered in order with preset keys.

Hold down the RADIO key.

After completion of auto store operations, the product will receive the station registered in the preset key [1].

CAUTION

- Please be aware that the formerly-registered frequency in the memory will be overwritten.

NOTE

- Using auto store for FM1 and FM2 switches to FM3.

PTY Search

Select PTY (program content), and automatically scan for stations.

1. During FM reception, press the PTY/SCAN key.

This switches to the PTY selection mode.

2. Turn the /SEL key to select PTY. The PTY (program content) indicator will flash, and station selection will automatically start. When a station is received, the station name is displayed.

NOTE

- This receives the station detected first.
- 10 seconds after reception, PTY search mode will be cancelled.

8

Listen to DAB*

E00739100014

This explains how to listen to DAB.

To listen to DAB

1. Press the RADIO key to switch the band. Switch between DAB1, DAB2, and DAB3 bands. The selected band is indicated on the display.

Listen to DAB*

NOTE

- This switches in the order FM1, FM2, FM3, DAB1, DAB2, DAB3, MW, and LW.

Select a Service

1. Hold down the **1◀◀** key or the **▶▶1** key.
Receives the lead services of the ensembles that can be received.
2. Press the **1◀◀** key or the **▶▶1** key to select the service.

8

1◀◀ key (hold down)	Automatically receives lower lead services within ensembles that can be received.
▶▶1 key (hold down)	Automatically receives higher lead services within ensembles that can be received.
1◀◀ key	Switches to lower services.
▶▶1 key	Switches to higher services.

NOTE

- Going to the first service or last service within the ensemble switches to the next ensemble.

Register the Service

Register the service in advance, and select this at a later time.

1. Tune in to the service to register.
2. Hold down any of the keys from the 1RPT key to the 6 ➡ key.
A “Beep” sounds, and the preset key is registered.

NOTE

- If a preset key that already has a service registered is selected, then this is overwritten with the new preset.
- Pressing the preset key will select the previously registered service.

Search for a Service

Search for ensembles and services that can be received.

1. Turn the **▶/SEL** key to select the ensemble.
2. Press the **▶/SEL** key.
The service name within the selected ensemble is displayed.
3. Turn the **▶/SEL** key to select the service.
4. Press the **▶/SEL** key.
Receive the selected service.

NOTE

- If the text information for the service name cannot be obtained, then nothing is displayed.
- If there is no operation for 10 seconds, then service search mode will be cancelled.

PTY Search

Select PTY (program content), and automatically scan for services.

1. Press the PTY/SCAN key.
This switches to the PTY selection mode.
2. Turn the **▶/SEL** key to select PTY.
3. Press the **1◀◀** key or **▶▶1** key.
This starts PTY search.

1◀◀ key	Lower PTY search starts.
▶▶1 key	Higher PTY search starts.

NOTE

- When selecting PTY, press any of the keys from the 1RPT key to the 6 ➡ key to switch to the PTY registered as a preset.
- When selecting PTY, select the PTY to register, and hold down any of the keys from the 1RPT key to the 6 ➡ key to register the PTY as a preset.

NOTE

- While in PTY select status, if there is no operation for 2 seconds, then an upwards search within the selected PTY will start.

Listen to Traffic Messages

E00739200015

This explains how to listen to traffic messages.

To Listen to Traffic Messages

1. When not in MW or LW mode, press the TP key.
If traffic messages are being broadcast, these are received.

CAUTION

- When receiving a MW or LW signal, traffic messages cannot be received.

NOTE

- Receiving traffic messages will indicate "TRAF INF" on the display, and if text information can be received, the station name is displayed.

NOTE

- If traffic messages are received, then this will switch to the volume of the previously received traffic messages or emergency broadcasts. The volume when receiving traffic messages or emergency broadcasts is that at which subsequent broadcasts will be received.

Traffic Message Standby Mode

When the broadcast of traffic messages starts, this automatically switches to the station that is broadcasting traffic messages.

1. When not in MW or LW mode, press the TP key.
"TP" is indicated on the display, and the product switches to standby mode.
If traffic messages are being broadcast, these are received.
2. When not in MW or LW mode, press the TP key.
"TP" disappears from the display, and standby mode will be cancelled.

CAUTION

- When receiving a MW or LW signal, traffic message standby mode will be cancelled.

Listen to CDs

E00737800059

This explains how to listen to audio CDs (CD-DA/CD-TEXT).

Play CDs

Insert the disc.

Insert a disc to automatically start playback. → "Insert/Eject Discs" on page 8-26

If a disc is already within the product, press the MEDIA key to switch to CD as the source.

8**Select the Track**

Press the ◀◀ key or ▶▶ key to select the track.

This enables selection of the next or previous track.

Fast Forward or Rewind

Hold down the 3◀◀ key or the 4▶▶ key.

Fast forward/rewind is possible.

Switch Playback Mode

Repeat playback, random playback, and scan playback are possible.

For pleasant driving 8-31

Listen to MP3s

Repeat Playback (RPT)

Press the 1RPT key.

Repeat playback of the track currently being played.

NOTE

- Pressing again will cancel.
- Selecting a track, ejecting, fast forwarding, or rewinding will cancel.

8

Random Playback (RDM)

Press the 2RDM key.

Play the tracks on the disc in a random order.

NOTE

- Pressing again will cancel.
- Ejecting will cancel this.

Scan Playback (SCAN)

Press the PTY/SCAN key.

Play the first 10 seconds of each of the tracks on the whole disc in order.

NOTE

- Press this button again during playback if you wish to hear that track, and that track will play normally.

Listen to MP3s

E0073790034

This explains how to listen to audio files on a disc.

CAUTION

- CD-ROM and CD-R/RW media can only play back MP3 format audio files.

To Listen to MP3s

Insert the disc.

Insert a disc to automatically start playback. → “Insert/Eject Discs” on page 8-26
If a disc is already within the product, press the MEDIA key to switch to CD as the source.

NOTE

- Depending on the file structure, it may take some time to read the contents of the disc.

Select the Track (File)

Press the 1◀◀ key or ▶▶1 key to select the track.

This enables selection of the next or previous track.

Fast Forward or Rewind

Hold down the 3◀◀ key or the 4▶▶ key.

Fast forward/rewind is possible.

Switch Playback Mode

Repeat playback, random playback, and scan playback are possible.

Repeat Playback (RPT)

Press the 1RPT key.

Repeat playback of the track currently being played.

NOTE

- Pressing again will cancel.
- Selecting a file, ejecting, fast forwarding, or rewinding will cancel.

Folder Repeat Playback

Hold down the 1RPT key.

Repeat playback of the tracks within the folder currently being played.

NOTE

- Pressing again will cancel.
- Even if the file is selected, folder repeat playback will not be cancelled.

Random Playback (RDM)

Press the 2RDM key.

Play the tracks in the folder in a random order.

NOTE

- Pressing again will cancel.

Folder Random Playback

Hold down the 2RDM key.

Play all tracks in folders on the disc in a random order.

NOTE

- Pressing again will cancel.

Scan Playback (SCAN)

Press the SCAN key.

Play the first 10 seconds of each of the tracks in the folder currently being played in order.

Search Tracks

Search folders and files, and select a track.

1. Turn the **▶/SEL** key to select the folder.
2. Press the **▶/SEL** key.

Files within the selected folder are displayed.

3. Turn the **▶/SEL** key to select the file.
4. Press the **▶/SEL** key.

This plays the selected file (track).

NOTE

- While the folder is selected, press the **6 ↵** key to cancel track search mode.
- If there is no operation for 10 seconds after selecting the folder, then track search mode will be cancelled.

NOTE

- Select the folder, and hold down the **▶/SEL** key to start playback from the first track in that folder.
- While the file is selected, press the **6 ↵** key to return to the previous operation.
- While the file is selected, hold down the **6 ↵** key to cancel track search mode.
- If there is no operation for five seconds after selecting the file, that file is played back.
- Disc operations such as selecting a track will cancel track search mode.

Listen to an iPod

E00738001202

By connecting commercially-available iPod/iPhone devices to this product, you can play back tracks on these through the product.

CAUTION

- Do not leave the iPod/iPhone unattended in the vehicle.
- Never hold these devices in your hand to operate while driving, as this is dangerous.
- No indemnification for data loss resulting when the iPod/iPhone is connected to the product will be possible.
- Depending on how the devices are handled, audio files being damaged or lost, therefore it is recommended that data be backed up.

Listen to an iPod

NOTE

- Depending on the generation, model, or software version of the iPod/iPhone, playback on this product may not be possible. (→8-16) Additionally, playback as explained in this document may not be possible.
- For vehicles with a Bluetooth® 2.0 interface, the types of devices that can be connected may vary.
For details, access the MITSUBISHI MOTORS website.
Please read and agree to the “Warning about Links to the Web Sites of Other Companies”. The websites mentioned above may connect you to websites other than the MITSUBISHI MOTORS website.
<http://www.mitsubishi-motors.com/en/products/index.html>
- Usage of iPod/iPhone hardware with the latest software version is recommended.
- Regarding how to connect the iPod/iPhone, refer to “How to connect an iPod” on page 8-72.
- When connecting the iPod/iPhone, use a commercially available iPod connection cable.
- Set up the device in order that no unsafe actions, such as plugging in the connection cable are taken while driving.
- When inserting and removing the iPod/iPhone, for safety’s sake first stop the vehicle.
- Depending on the status of the iPod/iPhone, it may take some time until the device is recognized, or playback starts.

8-34 For pleasant driving

NOTE

- Depending on the iPod/iPhone, the button functions on the product may not operate while the iPod/iPhone is connected.
- iPod/iPhone specifications and settings may mean that connection is not possible, or result in differences in operation or display.
- Depending on audio data in the iPod/iPhone, track information may not be displayed correctly.
- Depending on the status of the vehicle and device, the iPod/iPhone may not play back after starting the Plug-in Hybrid EV system.
- Data containing copyright information may not play back.
- It is recommended that the iPod/iPhone equaliser settings be set to flat.
- Operate the iPod/iPhone while connected to this product.
- If the iPod/iPhone is connected via Bluetooth as a Bluetooth- capable audio device, then do not connect the iPod/iPhone using an iPod cable. Connection using both methods will result in erroneous operation.
- If an iPod/iPhone does not operate correctly, then remove the iPod/iPhone from the product, reset, then reconnect.

Play iPod

Press the MEDIA key to set the iPod as the source.

The selected source is indicated on the display.

OGGE19E1

Select the Track (File)

Press the **1◀◀** key or **▶▶1** key to select the track.

This enables selection of the next or previous track.

Fast Forward or Rewind

Hold down the **3◀◀** key or the **4▶▶** key.

Fast forward/rewind is possible.

Switch Playback Mode

Repeat playback and shuffle playback are possible.

Repeat Playback (RPT)

Press the **1RPT** key.

Repeat playback of the track currently being played.

NOTE

- Pressing again will cancel.

Shuffle Playback (RDM)

Press the **2RDM** key.

Play tracks in the category currently being played in a random order.

NOTE

- Pressing again will cancel.

Album Shuffle Playback

Hold down the 2RDM key.

Play back the album in a random order (tracks in any order on the album).

NOTE

- Pressing again will cancel.

Search Tracks

Search categories or track names, and select a track.

1. Turn the **▶/SEL** key to select the category.
2. Press the **▶/SEL** key. Categories or tracks within the selected category are displayed.
3. Turn the **▶/SEL** key to select the category or track.

4. Press the **▶/SEL** key.

Repeat steps 1 to 4, and search for tracks.

Select the track, and press the **▶/SEL** key to play.

NOTE

- While the category (1st level) is selected, press the **6 ↵** key to cancel track search mode.
- If there is no operation for 10 seconds after selecting the category, then track search mode will be cancelled.
- Select the category, and hold down the **▶/SEL** key to start playback from the first track in that category.
- While the track is selected, press the **6 ↵** key to return to the previous operation.
- While the track is selected, hold down the **6 ↵** key to cancel track search mode.
- If there is no operation for five seconds after selecting the track, that file is played back.
- iPod operations such as selecting a track will cancel track search mode.

Listen to Audio Files on a USB Device

E00736501261

By connecting commercially-available USB devices such as USB memory to this product, you can play back audio files on these through the product.

Listen to Audio Files on a USB Device

CAUTION

- Do not leave the USB device unattended in the vehicle.
- Never hold these devices in your hand to operate while driving, as this is dangerous.
- Do not use hard discs, card readers, or memory readers, as damage may occur to these or to the data contained therein. If these are erroneously connected, put the operation mode of the power switch in OFF and then remove them.
- Because of the risk of data loss, it is recommended that files be backed up.
- No guarantee is made as regards damage to the USB device, nor regarding loss or damage to data contained therein.
- Depending on how the devices are handled, audio files being damaged or lost, therefore it is recommended that data be backed up.

8

NOTE

- Digital audio players that support the mass storage class specifications can be connected.
- For details regarding the types of USB devices that can be connected and the types of files that can be played back in vehicles with a Bluetooth[®] 2.0 interface, refer to “Types of connectable devices and supported file specifications” on page 8-72.
- Regarding how to connect USB devices, refer to “How to connect a USB memory device” on page 8-72.

Listen to Audio Files on a USB Device

NOTE

- When connecting a USB device, use a connection cable. Failure to use a connection cable when connecting may place undue load on, or damage the USB connector.
- Set up the device in order that no unsafe actions, such as plugging in the connection cable are taken while driving.
- When inserting and removing the USB device, for safety's sake first stop the vehicle.
- Do not insert other than audio devices into the USB port. Damage to the device or equipment may result.
- Depending on the status of the USB device, it may take some time until the device is recognized, or playback starts.
- Depending on the USB device, the button functions on the product may not operate while the USB device is connected.
- USB device specifications and settings may mean that connection is not possible, or result in differences in operation or display.
- Depending on audio data in the USB device, track information may not be displayed correctly.
- Depending on the status of the vehicle and device, the iPod/iPhone may not play back after starting the Plug-in Hybrid EV system.
- Data containing copyright information may not play back.
- This product can play back MP3, WMA, and AAC format audio files.
- Depending on the type of USB device, usage may not be possible, or functions that can be used may be restricted.

8

NOTE

- The recommended file system for USB memory is FAT32.
- The maximum supported capacity for USB memory is 32GB.
- Operate the USB device containing recorded audio files while connected to this product.

Play Back of Audio Files on a USB Device

Press the MEDIA key to set

USB as the source. The selected source is indicated on the display.

Select the Track (File)

Press the ◀◀ key or ▶▶ key to select the track.

This enables selection of the next or previous track.

Fast Forward or Rewind

Hold down the 3◀◀ key or the 4▶▶ key.

Fast forward/rewind is possible.

Switch Playback Mode

Repeat playback, random playback, and scan playback are possible.

Repeat Playback (RPT)

Press the 1RPT key.

Repeat playback of the track currently being played.

NOTE

- Pressing again will cancel.
- Selecting a file will cancel this.

Folder Repeat Playback

Hold down the 1RPT key.

Repeat playback of the tracks within the folder currently being played.

NOTE

- Pressing again will cancel.
- Even if the file is selected, folder repeat playback will not be cancelled.

Folder Random Playback (RDM)

Press the 2RDM key.

To play iPod/USB memory device tracks via voice operation (vehicles with Bluetooth® 2.0 interface)

Play tracks in the folder currently being played in a random order.

NOTE

- Pressing again will cancel.
- Even if the file is selected, folder random playback will not be cancelled.

All Folder Random Playback

Hold down the 2RDM key.

Play the tracks in all folders in a random order.

NOTE

- Pressing again will cancel.
- Even if the file is selected, all folder random playback will not be cancelled.

Scan Playback (SCAN)

Press the PTY/SCAN key.

Play the first 10 seconds of each of the tracks on the whole USB device in order.

NOTE

- Press this button again during playback if you wish to hear that track, and that track will play normally.

Folder Scan Playback

Hold down the PTY/SCAN key.

Play the first 10 seconds of the first track in each folder on the USB device in order.

NOTE

- Press this button again during playback if you wish to hear that track, and that track will play normally.

Search Tracks

Search folders and files, and select a track.

1. Turn the ▶/SEL key to select the folder.
2. Press the ▶/SEL key.

Files within the selected folder are displayed.

3. Turn the ▶/SEL key to select the file.
4. Press the ▶/SEL key.

This plays the selected file (track).

NOTE

- While the folder is selected, press the 6 ➡ key to cancel track search mode.
- If there is no operation for 10 seconds after selecting the folder, then track search mode will be cancelled.
- Select the folder, and hold down the ▶/SEL key to start playback from the first track in that folder.
- While the file is selected, press the 6 ➡ key to return to the previous operation.
- While the file is selected, hold down the 6 ➡ key to cancel track search mode.
- If there is no operation for five seconds after selecting the file, that file is played back.
- Operations such as selecting a track will cancel track search mode.

To play iPod/USB memory device tracks via voice operation (vehicles with Bluetooth® 2.0 interface)

E00748700029

Desired tracks on the iPod/USB memory device which is connected to the USB input terminal can be selected and played via voice operation.

For information concerning the voice recognition function or speaker registration function, refer to “Bluetooth® 2.0 interface” on page 8-51.

For pleasant driving 8-37

To play iPod/USB memory device tracks via voice operation (vehicles with Bluetooth® 2.0 interface)

The following explains how to prepare for voice operation and play the tracks.

Preparation for voice operation

E00748800059

To use the voice operation, press the SPEECH button (A) first.

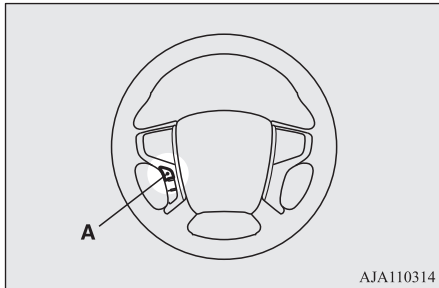

8

To search by artist name

E00748900021

1. Say "Play" on the main menu.

NOTE

- The Bluetooth® 2.0 interface starts recognizing the connected device. If the connected device cannot be recognized or a connection error occurs, the Bluetooth® 2.0 interface starts an appropriate voice guide. Follow the voice guide.

NOTE

- If you say "Artist <name>," you can skip step 3.

3. After the voice guide says "What Artist would you like to play?," say the artist name.
4. If there is only one match, the system proceeds to step 6.
5. If there are two or more matches, the voice guide will say "More than one match was found, would you like to play <artist name>?" If you say "Yes," the system proceeds to step 6. If you say "No," the next matching artist is uttered by the system.

NOTE

- If you say "No" to three or all artist names uttered by the system, the voice guide will say "Artist not found, please try again" and the system returns to step 2.
- Search time is dependant on the number of songs on your connected device. Devices containing a large number of songs may take longer to return search results.

6. After the voice guide says "Playing <artist name>," the system creates a playlist index for the artist.

NOTE

- If the confirmation function is active, the voice guide confirms if the artist name is correct. If the artist name is correct, say "Yes". If not, say "No". After the voice guide says "Artist not found, please try again," the system returns to step 2.

7. The system exits the voice recognition mode and starts playback.

To search by album title

E00749000029

1. Say "Play" on the main menu.

NOTE

- The Bluetooth® 2.0 interface starts recognizing the connected device. If the connected device cannot be recognized or a connection error occurs, the Bluetooth® 2.0 interface starts an appropriate voice guide. Follow the voice guide.

2. After the voice guide says "Would you like to play by Artist, Album, Playlist or Genre?," say "Album".

To play iPod/USB memory device tracks via voice operation (vehicles with Bluetooth® 2.0 interface)

NOTE

- If you say “Album <title>,” you can skip step 3.

3. After the voice guide says “What Album would you like to play?” say the album title.
4. If there is only one match, the system proceeds to step 6.
5. If there are two or more matches, the voice guide will say “More than one match was found, would you like to play <album title>?” If you say “Yes,” the system proceeds to step 6. If you say “No,” the next matching album is uttered by the system.

NOTE

- If you say “No” to three or all album titles uttered by the system, the voice guide will say “Album not found, please try again” and the system returns to step 2.

6. After the voice guide says “Playing <album title>,” the system creates a playlist index for the album title.

NOTE

- If the confirmation function is active, the voice guide confirms if the album title is correct. If the album title is correct, say “Yes”. If not, say “No”. After the voice guide says “Album not found, please try again,” the system returns to step 2.

7. The system exits the voice recognition mode and starts playback.

To search by playlist

E00749100020

1. Say “Play” on the main menu.

NOTE

- The Bluetooth® 2.0 interface starts recognizing the connected device. If the connected device cannot be recognized or a connection error occurs, the Bluetooth® 2.0 interface starts an appropriate voice guide. Follow the voice guide.

2. After the voice guide says “Would you like to play by Artist, Album, Playlist or Genre?” say “Playlist”.

NOTE

- If you say “Playlist <playlist>,” you can skip step 3. If the device has no playlist, the voice guide will say “There are no playlists stored on device” and the system returns to step 2.

3. After the voice guide says “What Playlist would you like to play?” say the playlist name.
4. If there is only one match, the system proceeds to step 6.
5. If there are two or more matches, the voice guide will say “More than one match was found, would you like to play <playlist>?” If you say “Yes,” the system proceeds to step 6. If you say “No,” the next matching playlist name is uttered by the system.

NOTE

- If you say “No” to three or all playlist names uttered by the system, the voice guide will say “Playlist not found, please try again” and the system returns to step 2.

6. After the voice guide says “Playing <playlist>,” the system creates an index for the playlist.

Listen to Bluetooth Audio*

NOTE

- If the confirmation function is active, the voice guide confirms if the playlist name is correct. If the playlist name is correct, say “Yes”. If not, say “No”. After the voice guide says “Playlist not found, please try again,” the system returns to step 2. Refer to “Confirmation function setting” on page 8-54.

7. The system exits the voice recognition mode and starts playback.

8

To search by genre

E00749200021

1. Say “Play” on the main menu.

NOTE

- The Bluetooth^(R) 2.0 interface starts recognizing the connected device. If the connected device cannot be recognized or a connection error occurs, the Bluetooth^(R) 2.0 interface starts an appropriate voice guide. Follow the voice guide.

2. After the voice guide says “Would you like to play by Artist, Album, Playlist or Genre?,” say “Genre”.

NOTE

- If you say “Genre <type>,” you can skip step 3.

3. After the voice guide says “What Genre would you like to play?,” say the music type.

4. If there is only one match, the system proceeds to step 6.

5. If there are two or more matches, the voice guide will say “More than one match was found, would you like to play <genre>?” If you say “Yes,” the system proceeds to step 6.

If you say “No,” the next matching genre is uttered by the system.

NOTE

- If you say “No” to three or all genres uttered by the system, the voice guide will say “Genre not found, please try again” and the system returns to step 2.

6. After the voice guide says “Playing <genre>,” the system creates an index for the genre.

NOTE

- If the confirmation function is active, the voice guide confirms if the genre is correct. If the genre is correct, say “Yes”. If not, say “No”. After the voice guide says “Genre not found, please try again,” the system returns to step 2. Refer to “Confirmation function setting” on page 8-54.

7. The system exits the voice recognition mode and starts playback.

Listen to Bluetooth Audio*

E00736701234

This product can play back tracks on commercially-available Bluetooth-capable audio devices.

CAUTION

- Never hold these devices in your hand to operate while driving, as this is dangerous.
- Do not leave the Bluetooth audio device unattended in the vehicle.
- Depending on how the devices are handled, audio files being damaged or lost, therefore it is recommended that data be backed up.

NOTE

- Depending on the type of Bluetooth-capable audio devices, usage may not be possible, or functions that can be used may be restricted.
- Confirm together with the user manuals for the commercially- available Bluetooth-capable audio devices.
- Depending on the type of Bluetooth-capable audio devices, volume levels may differ. There is the danger of loud volumes, so prior to use, it is recommended that you turn the volume down.
→ “Adjust Volume” on page 8-26
- Depending on the status of the Bluetooth audio device, it may take some time until the device is recognized, or playback starts.
- Bluetooth audio device specifications and settings may mean that connection is not possible, or result in differences in operation or display.
- Depending on audio data in the Bluetooth audio device, track information may not be displayed correctly.
- Depending on the status of the vehicle and device, the iPod/iPhone may not play back after starting the Plug-in Hybrid EV system.

Connect a Bluetooth-capable Audio Device

Regarding how to connect your Bluetooth device, refer to “Connecting the Bluetooth® 2.0 interface and Bluetooth® device” on page 8-57.

Operation methods below describe situations once connection has been completed.

NOTE

- If the iPod/iPhone is connected via Bluetooth as a Bluetooth-capable audio device, then do not connect the iPod/iPhone using an iPod connection cable. Connection using both methods will result in erroneous operation.

Play Bluetooth Audio

1. Press the MEDIA key to set Bluetooth Audio as the source.

The selected source is indicated on the display.

2. Press the 5 **▶||** key. Bluetooth Audio playback starts.

NOTE

- Hold down the 5 **▶||** key to pause.
- Press the 6 **↵** key to stop.

Select the Track (File)

Press the **◀◀** key or **▶▶** key to select the track.

This enables selection of the next or previous track.

Fast Forward or Rewind

Hold down the 3 **◀◀** key or the 4 **▶▶** key.

Fast forward/rewind is possible.

Switch Playback Mode

Repeat playback, random playback, and scan playback are possible.

Repeat Playback (RPT)

Press the 1RPT key.

Repeat playback of the track currently being played.

NOTE

- Each time the 1RPT key is pressed, this switches in the order Repeat OFF, 1 track repeat, All track repeat, and Repeat OFF.

Random Playback (RDM)

Press the 2RDM key.

Play the tracks in the Bluetooth Audio device in a random order.

Listen to Bluetooth Audio*

 **NOTE**

- Pressing again will cancel.

Scan Playback (SCAN)

Press the PTY/SCAN key.

Play the first 10 seconds of each of the tracks on the whole Bluetooth Audio device in order.

8

 **NOTE**

- Press this button again during playback if you wish to hear that track, and that track will play normally.

Display Indicator

E00738100033

This explains content of the display indicator.

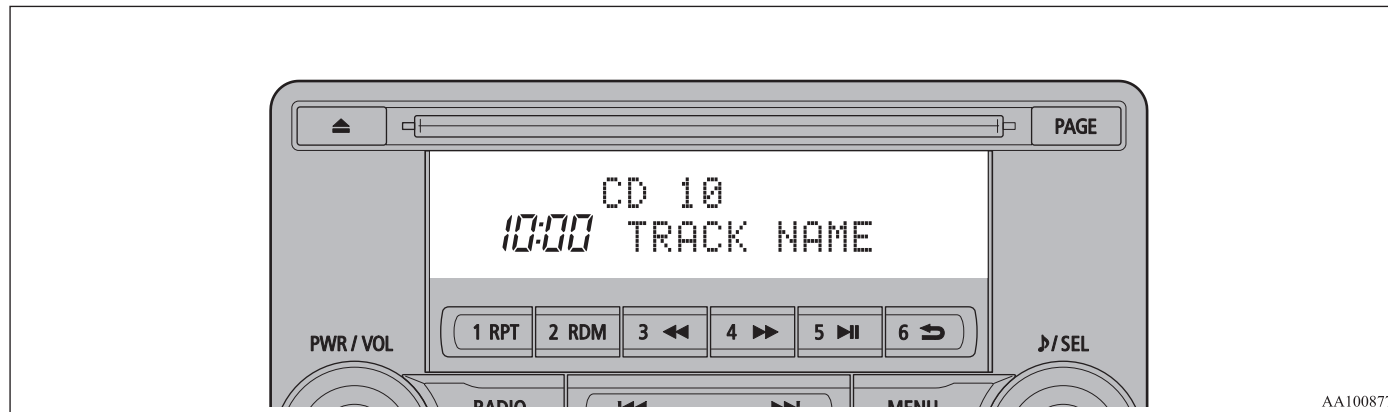

8

AA1008779

Change the Display Mode

E00738501177

You can change the content of the display indicator.

Press the DISP key to switch the display content.

Each time the DISP key is pressed, the display content changes.

CAUTION

- The operation of changing display contents may impede safe driving, therefore check safety before operation.

NOTE

- Up to 11 characters may be displayed at one time. To display 12 or more characters, press the PAGE key, and subsequent characters will be displayed.

During DAB Reception*

This switches in the order “Service name”, “Ensemble name”, and “CH no. (CH ID)”.

NOTE

- If the text information for the service name and ensemble name cannot be obtained, then nothing is displayed.

Audio Quality and Volume Balance Adjustment

During CD-DA playback

This switches in the order “Disc title”, “Track title”, and “Operating status”.

NOTE

- If there is no text information to display, then “NO TITLE” is displayed.

During MP3/WMA/AAC Playback

This switches in the order “Folder title”, “File title”, and “Operating status”.

NOTE

- If there is no text information to display, then “NO TITLE” is displayed.

Display the ID3tag

Hold down the DISP key.

This switches the ID3tag display.
[DISP] Each time the key is pressed, this switches in the order “Album name”, “Track name”, “Artist name”, “Genre name”*, and “Operating status”.

*: Displayed when playing back audio files on a USB device (vehicles with a Bluetooth® 2.0 interface).

NOTE

- During display of the ID3tag, hold down the DISP key to switch to the folder title display.
- The genre name display may not be possible.

During iPod Playback

This switches in the order “Albums”, “Track name”, “Artist name”, “Genre name”*, and “Operating status”.

NOTE

- If there is no text information to display, then “NO TITLE” is displayed.
- Displayed genre name in equipment by type (vehicles with a Bluetooth® 2.0 interface).
- The genre name display may not be possible.

During Bluetooth® 2.0 Audio Playback*

Operating details are the same as in “During iPod Playback” on page 8-44.

Audio Quality and Volume Balance Adjustment

Change audio quality settings.

Adjust Audio Quality and Volume Balance

1. Press the **▶**/SEL key to select settings items.
Each time the **▶**/SEL key is pressed, this switches in the order BASS, TREBLE, FADER, BALANCE, SCV (speed compensated volume), and Cancel.
2. Turn the **▶**/SEL key to adjust.

Adjustment items	Turn counter-clockwise	Turn clockwise
BASS	-6 to 0 (low low-pass volume)	0 to +6 (high low-pass volume)
TREBLE	-6 to 0 (Low high-pass volume)	0 to +6 (High high-pass volume)
FADER	CENTER to REAR 11 (emphasise REAR)	FRONT 11 to CENTER (emphasise FRONT)
BALANCE	LEFT 11 to CENTER (emphasise LEFT)	CENTER to RIGHT 11 (emphasise RIGHT)

Adjustment items	Turn counter-clockwise	Turn clockwise
SCV	OFF, LOW (SCV effect is OFF/low)	MID, HIGH (SCV effect is middle/high)

System Settings

E00738301188

Change system settings such as product time.

1. Press the MENU key.
2. Press the **▶**/SEL key to select settings items.

Each time the **▶**/SEL key is pressed, this switches in the order DAB setting*¹, Gracenote DB*², AF, REG, TP-S, PI-S, PTY language settings, PHONE settings, CT, Adjust time, and Cancel.

3. Turn the **▶**/SEL key to set.
4. Press the **▶**/SEL key to determine. This completes settings, and displays the next settings item.

*1: Displayed when a DAB tuner is connected.

*2: Displayed when playing back audio files (vehicles with a Bluetooth® 2.0 interface).

DAB Setting*

Change DAB settings

("Set value" bold typeface indicates factory default settings.)

Settings name	Settings value	Settings content
DAB-DAB Link settings	OFF	If low reception sensitivity, switch to another service.
	ON	
DAB Band settings	BAND III	Set used broadcast band to 174 to 239 MHz.
	L-BAND	Set used broadcast band to 1452 to 1490 MHz.
	BOTH	Set used broadcast band to Band III and L-Band.

RDS Setting

Change RDS settings

("Set value" bold typeface indicates factory default settings.)

Settings name	Settings value	Settings content
AF	AF ON	Automatically track the same station as the program being received.
	AF OFF	Do not automatically track the same station as the program being received.
REG	REG ON	Do not automatically track the local station for the program being received.

System Settings

Settings name	Settings value	Settings content
	REG OFF	Automatically track the local station for the program being received.
TP-S	TP-S ON	Automatically search for traffic messages (TP stations).
	TP-S OFF	Do not automatically search for traffic messages (TP stations).
PI-S	PI-S ON	Search for the same station or local station for that registered in the preset channel.

8

Settings name	Settings value	Settings content
	PI-S OFF	Do not search for the same station or local station for that registered in the preset channel.
PTY	ENGLISH	Set the display language for the program content search (PTY search) to English.
	FRANÇAIS	Set the display language for the program content search (PTY search) to French.
	DEUTSCH	Set the display language for the program content search (PTY search) to German.

Settings name	Settings value	Settings content
	SVENSK	Set the display language for the program content search (PTY search) to Swedish.
	ESPAÑOL	Set the display language for the program content search (PTY search) to Spanish.
	ITALIANO	Set the display language for the program content search (PTY search) to Italian.
CT	CT ON	Update the time if time data is received.

Settings name	Settings value	Settings content
	CT OFF	Do not update the time even if time data is received.

*: It is necessary to press the [TP] key and turn traffic message standby mode "ON".

Time Setting

Turning the RDS setting CT setting "CT OFF" enables manual setting of the time.

1. Select "YES" at the "Adjust time" screen, and press the **▶**/SEL key.

The hour can be adjusted. Press the **▶**/SEL key again to adjust the minutes.

2. Turn the **▶**/SEL key to adjust the time.
3. Press the **▶**/SEL key.

This completes the adjustment.

 NOTE
● In order to finish adjusting the time, hold down the ▶ /SEL key until the seconds are reset to "00".

PHONE Settings

Change the mobile phone voice cut-in settings and the Bluetooth® 2.0 interface language.

Depending on the vehicle, PHONE settings may not be possible.

 NOTE
● Cancel functions such as the mobile phone "dial lock", and connect while on the standby screen.
● While connected, mobile phone (receiving calls, etc.) operations may not function correctly.
● Depending on the distance between the product and the mobile phone, the conditions within the vehicle, and types of screening, connection may not be possible. In these cases, situate the mobile phone as close as possible to the product.
● Even though a Bluetooth-capable mobile phone, characteristics and specifications may mean that correct operation may not be possible.
● For safety's sake, do not operate the mobile phone while driving. When operating the mobile phone, first stop the vehicle in a safe location.
● Even though a Bluetooth-capable mobile phone, phone specifications and settings may result in differences in display, or prevent correct operation.

 NOTE
● Some models may not be confirmed as connected, or may not connect.

Supported profiles

Hands-free	HFP(v1.5)
Phone book transfer	OPP(v1.1), PBAP(v1.0)

Vehicles without a Bluetooth® 2.0 Interface

A hands-free kit (available separately) is required.

("Set value" bold typeface indicates factory default settings.)

Settings value	Settings content
PHONE OFF	Do not use mobile phone voice cut-in.
PHONE MUTE	During mobile phone voice cut-in, mute the audio.
PHONE ATT	During mobile phone voice cut-in, output audio from all speakers.

System Settings

Settings value	Settings content
PHONE IN-L	During mobile phone voice cut-in, output sound from the left front speaker.
PHONE IN-R	During mobile phone voice cut-in, output sound from the right front speaker.
PHONE IN-LR	During mobile phone voice cut-in, output sound from the left and right front speakers.

8

Vehicles with a Bluetooth® 2.0 Interface

("Set value" bold typeface indicates factory default settings.)

Settings name	Settings value	Settings content
PHONE IN settings	PHONE IN-R	During mobile phone voice cut-in, output sound from the right front speaker.

Settings name	Settings value	Settings content
	PHONE IN-L	During mobile phone voice cut-in, output sound from the left front speaker.
HFM voice language settings	ENGLISH	Change the hands free module voice language.
	FRENCH	
	GERMAN	
	SPANISH	
	ITALIAN	
	DUTCH	
	PORTUGUESE	
	RUSSIAN	

Gracenote DB (Vehicles with a Bluetooth® 2.0 interface)

The version number can be confirmed.

1. Select "Gracenote DB" and press the **▶/SEL** key.
2. Turn the **▶/SEL** key and select "DB Version".
3. Press the **▶/SEL** key.
The DB Version is displayed.

NOTE

- Depending on the vehicle model, this may not display.

Troubleshooting

E00738401075

Please check these items if a message appears on the display, or if you think something is not working properly.

If This Message Appears...

A message is displayed on this product according to the situation.

Mode	Message	Cause	Response
CD	CHECK DISC	The disc is inserted upside down.	Insert with the label side up.
		The disc has condensation on it.	Wait a while before inserting again.
	DISC ERROR	The disc is damaged.	Clean the read surface of the disc.
		The disc is dirty.	
	INTERNAL E	The drive has malfunctioned for some reason.	Check that there is no problem with the disc, and insert the disc again. If the problem persists, consult a MITSUBISHI MOTORS Authorized Service Point.
HEAT ERROR	The temperature inside the product is high.	Remove the disc, and wait for the internal temperature to return to normal.	
USB	FILE ERROR	Files that cannot be played are selected.	Select files that can be played. → “Audio Files (MP3/WMA/AAC)” on page 8-21
	USB BUS PWR	There is high or low electrical current or voltage.	Turn the power OFF and wait a short while. If the problem persists, consult a MITSUBISHI MOTORS Authorized Service Point.
	LSI ERROR	There is an internal malfunction for some reason.	
	UNSUPPORTED FORMAT	Unsupported audio files have been played.	Confirm audio files that can be played. → “Audio Files (MP3/WMA/AAC)” on page 8-21
	UNSUPPORTED DEVICE	An unsupported USB device has been connected.	Please connect a USB memory device.
iPod	NO SONG	An iPod/iPhone not containing any tracks has been connected.	Connect an iPod/iPhone containing tracks.

Troubleshooting

Mode	Message	Cause	Response
iPod	VER ERROR	This iPod/iPhone software version is not supported.	Please change to a supported software version.
Other	ERROR DC	An abnormal direct voltage has been sent to the speakers.	Turn the power OFF and wait a short while. If the problem persists, consult a MITSUBISHI MOTORS Authorized Service Point.

If You Think Something Is Not Working Properly...

Here is a list of symptoms, causes and responses if you think something is not working properly.

Symptoms	Cause	Response
There is no sound or quiet sound.	The volume is turned to its minimum.	Adjust the volume. → “Adjust Volume” on page 8-26
	The balance or fader is turned to one side.	Adjust the balance or fader. → “Adjust Audio Quality and Volume Balance” on page 8-44
The disc cannot be inserted.	A disc is already in the product.	Eject the disc. → “Insert/Eject Discs” on page 8-26
	There is no disc in the product, but the product says it is loading.	Press the eject button once. → “Insert/Eject Discs” on page 8-26
The disc cannot be played.	The disc is inserted upside down.	Insert with the label side up.
	The disc has condensation on it.	Wait a while before inserting.
	The disc is dirty.	Clean the read surface of the disc.
The sound skips in the same place.	The disc is damaged or dirty.	Check the disc.
There is no sound, even if the disc is inserted.	Damage to or dirt on the disc means that its data cannot be read.	Check the disc. Additionally, if using CD-R/RW discs, their characteristics may render them unable to be played.

Link System*

E00764501569

The Link System takes overall control of the devices connected via the USB input terminal or the Bluetooth® 2.0 interface allowing the connected devices to be operated by using the switches in the vehicle or voice commands. See the following section for details on how to operate.

Refer to “Bluetooth® 2.0 interface” on page 8-51.

Refer to “USB input terminal” on page 8-71.

Refer to “Listen to an iPod” on page 8-33.

Refer to “Listen to Audio Files on a USB Device” on page 8-35.

Refer to “To play iPod/USB memory device tracks via voice operation” on page 8-37.

Refer to “Listen to Bluetooth Audio” on page 8-40.

Bluetooth® is a registered trademark of BLUETOOTH SIG, INC.

Link System End User Licence Agreement

E00764601111

You have acquired a device that includes software licensed by MITSUBISHI MOTORS CORPORATION from Visteon Corporation, and their subsequent 3rd party suppliers. For a complete list of these 3rd party products and their end user licence agreements, please go to the following website. <http://www.jciblueconnect.com/faq/fulldisclosure.pdf>

Bluetooth® 2.0 interface*

E00726002547

The Bluetooth® 2.0 interface allows for making/receiving hands-free calls in the vehicle using a Bluetooth® compatible cellular phone based on the wireless communication technology commonly known as Bluetooth®. It also allows the user to play music, saved in a Bluetooth® music player, from the vehicle’s speakers.

The system is equipped with a voice recognition function, which allows you to make hands-free calls by simple switch operations and voice command operations using a defined voice tree.

The Bluetooth® 2.0 interface can be used when the operation mode is in ON or ACC.

OGGE19E1

Before you can use the Bluetooth® 2.0 interface, you must pair the Bluetooth® device and Bluetooth® 2.0 interface. Refer to “Connecting the Bluetooth® 2.0 interface and Bluetooth® device” on page 8-57.

Bluetooth® is a registered trademark of BLUETOOTH SIG, INC.

⚠ WARNING

- Although the Bluetooth® 2.0 interface allows you to make hands-free calls, if you choose to use the cellular phone while driving, you must not allow yourself to be distracted from the safe operation of your vehicle. Anything, including cellular phone usage, that distracts you from the safe operation of your vehicle increases your risk of an accident.
- Refer to and comply with all state and local laws in your area regarding cellular phone usage while driving.

8

Bluetooth® 2.0 interface*

NOTE

- If the operation mode is left in ACC, the accessory power will automatically turn off after a certain period of time and you will no longer be able to use the Bluetooth® 2.0 interface. The accessory power comes on again if the power switch is operated. Refer to “ACC power auto-cutout function” on page 7-13.
- The Bluetooth® 2.0 interface cannot be used if the Bluetooth® device has a flat battery or the device power is turned off.
- Hands-free calls will not be possible if your phone does not have service available.
- If you place the Bluetooth® device in the luggage compartment, you may not be able to use the Bluetooth® 2.0 interface.
- Some Bluetooth® devices are not compatible with the Bluetooth® 2.0 interface.
- You can confirm the Link System software version by pressing the HANG-UP button 3 times (press and hold 2 times and then press briefly) within 10 seconds.
- For details on the Bluetooth® 2.0 interface, you can see them by accessing the MITSUBISHI MOTORS website. Please read and agree on the “Warning about Links to the Web Sites of Other Companies” because it connects to other than MITSUBISHI MOTORS website.
<http://www.mitsubishi-motors.com/en/products/index.html>

8

NOTE

- Software updates by cellular phone/digital audio device manufacturers may change/alter device connectivity.

Steering control switch and microphone
→ p. 8-52

Voice recognition function → p. 8-53

Useful voice commands → p. 8-54

Speaker enrollment function → p. 8-56

Connecting the Bluetooth® 2.0 interface and Bluetooth® device → p. 8-57

Operating a music player connected via Bluetooth® → p. 8-62

How to make or receive hands-free calls
→ p. 8-62

Phone book function → p. 8-65

Steering control switch and microphone

E00727201451

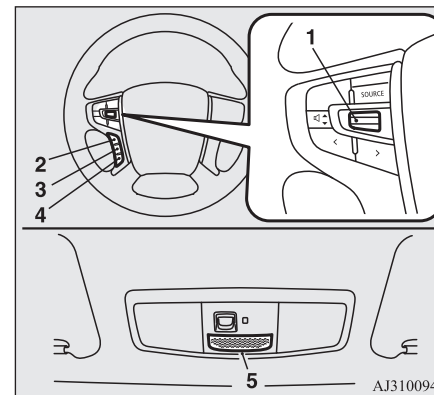

- 1- Volume up/down switch
- 2- SPEECH button
- 3- PICK-UP button
- 4- HANG-UP button
- 5- Microphone

Volume up switch

Push up this switch to increase the volume.

Volume down switch

Push down this switch to decrease the volume.

SPEECH button

- Press this button to change to voice recognition mode.
While the system is in voice recognition mode, “Listening” will appear on the audio display.
- If you press the button briefly while in voice recognition mode, it will interrupt prompting and allow voice command input.
Pressing the button longer will deactivate the voice recognition mode.
- Pressing this button briefly during a call will enable voice recognition and allow voice command input.

PICK-UP button

- Press this button when an incoming call is received to answer the telephone.
- When another call is received during a call, press this button to put the first caller on hold and talk to the new caller.
 - In such circumstances, you can press the button briefly to switch between callers. You will switch to the first caller and the other caller will be put on hold.
 - To establish a three-way call in such situations, press the SPEECH button to enter voice recognition mode and then say “Join calls”.

HANG-UP button

- Press this button when an incoming call is received to refuse the call.
- Press this button during a call to end the current call.
When another call is on hold, you will switch to that call.
- If this button is pressed in the voice recognition mode, the voice recognition mode will be deactivated.

NOTE

- When you press the SPEECH button to enter voice recognition mode with a cellular phone paired to the system, current information on the cellular phone, such as “remaining battery life,” “signal strength” or “roaming,” will be displayed on the audio display.*
*: Some cellular phones will not send this information to the Bluetooth® 2.0 interface.
- Call waiting and three-way calls can be used by the Bluetooth® 2.0 interface, only if it is possible to use those services with your cellular phone.

Microphone

Your voice will be recognized by a microphone in the overhead console, allowing you to make hands-free calls with voice commands.

NOTE

- If a cellular phone is brought close to the microphone, it may create noise in the voice on the phone. In such a case, take the cellular phone at a place as far as possible from the microphone.

Voice recognition function

E00727300514

The Bluetooth® 2.0 interface is equipped with a voice recognition function. Simply say voice commands and you can perform various operations and make or receive hands-free calls.

With the Bluetooth® 2.0 interface, voice recognition is possible for English, French, Spanish, Italian, German, Dutch, Portuguese and Russian. The factory setting is “English” or “Russian.”

NOTE

- If the voice command that you say differs from the predefined command or cannot be recognised due to ambient noise or some other reason, the Bluetooth® 2.0 interface will ask you for the voice command again up to 3 times.

Bluetooth® 2.0 interface*

NOTE

- For best performance and further reduction of ambient noise, close the vehicle windows, lower the blower speed and refrain from conversation with your passengers while engaging the voice recognition function.
- Some voice commands have alternative commands.
- Depending on the selected language, some functions may not be available.

Selecting the Language

8

1. Press the SPEECH button.
2. Say “Setup”.
3. Say “Language.”
4. The voice guide will say “Select a language: English, French, Spanish, Italian, German, Dutch, Portuguese or Russian”
Say the desired language. (Example: Say “English.”)
5. The voice guide will say “English (French, Spanish, Italian, German, Dutch, Portuguese or Russian) selected. Is this correct?” Say “Yes.”
Answer “No” to return to Step 4.

NOTE

- The voice guide will repeat the same message twice. The first message is in the current language, and the second message is in the selected language.

NOTE

- If many entries are registered in the vehicle phone book, changing the language will take longer.
- Changing the language deletes the mobile phone book imported to the Bluetooth® 2.0 interface. If you wish to use it, you will have to import it again.

6. When the voice guide says “English (French, Spanish, Italian, German, Dutch, Portuguese or Russian) selected,” the language change process will be completed and the system will return to the main menu.

Useful voice commands

E0076000019

Help function

E00760100010

The Bluetooth® 2.0 interface is equipped with a help function.

If you say “Help” when the system is waiting for a voice command input, the system will tell you a list of the commands that can be used under the circumstances.

Cancelling

E00760201021

There are two cancel functions.
If you are at the main menu, say “Cancel” to exit from the Bluetooth® 2.0 interface.

If you are anywhere else within the system, say “Cancel” to return to the main menu.

NOTE

- You can return to the previous menu by saying “Go Back.” (if so equipped)

Confirmation function setting

E00760400013

The Bluetooth® 2.0 interface is equipped with a confirmation function.

With the confirmation function activated, you are given more opportunities than normal to confirm a command when making various settings to the Bluetooth® 2.0 interface. This allows you to decrease the possibility that a setting is accidentally changed.

The confirmation function can be turned on or off by following the steps below.

1. Press the SPEECH button.
2. Say “Setup”.
3. Say “Confirmation prompts”.
4. The voice guide will say “Confirmation prompts are <on/off>. Would you like to turn confirmation prompts <off/on>”.
Answer “Yes” to change the setting or answer “No” to keep the current setting.
5. The voice guide will say “Confirmation prompts are <off/on>” and then the system will return to the main menu.

Security function

E00760501242

It is possible to use a password as a security function by setting a password of your choice for the Bluetooth® 2.0 interface.

When the security function is turned on, it is necessary to make a voice input of a 4-digit password in order to use all functions of the Bluetooth® 2.0 interface, except for reception.

Setting the password

Use the following procedure to turn on the security function by setting a password.

1. Press the SPEECH button.
2. Say "Setup".
3. Say "Password."
4. The voice guide will say "Password is disabled. Would you like to enable it?" Answer "Yes."
Answer "No" to cancel the setting of the password and return to the main menu.
5. The voice guide will say "Please say a 4-digit password. Remember this password. It will be required to use this system".
Say a 4-digit number which you want to set as a password.
6. For confirmation purposes, the voice guide will say "Password <4-digit password>. Is this correct?" Answer "Yes."
Answer "No" to return to the password input in Step 5.

7. When the registration of the password is completed, the voice guide will say "Password is enabled" and the system will return to the main menu.

NOTE

- After activating Plug-in Hybrid EV system again and pressing SPEECH button, you are asked to tell your password.
- The set password is actually recorded in the Link system after a while after the ready indicator goes out.
If you set the operation mode to ACC or ON or activate Plug-in Hybrid EV system soon after the ready indicator goes out, the set password may not be recorded in the Link system in some cases. In such a case, set your password again.

Entering the password

If a password has been set and the security function is enabled, the voice guide will say "Hands-free system is locked. State the password to continue" when the SPEECH button is pressed to enter voice recognition mode. Say the 4-digit password number to enter the password.

If the entered password is wrong, the voice guide will say "<4- digit password>, Incorrect password. Please try again". Enter the correct password.

NOTE

- You can re-enter the password as many times as you want.
- If you have forgotten your password, say "Cancel" to quit the voice input mode and then check with a MITSUBISHI MOTORS Authorized Service Point.

Disabling the password

Use the following procedure to turn off the security function by disabling the password.

NOTE

- System must be unlocked to disable the password.

1. Press the SPEECH button.
2. Say "Setup".
3. Say "Password."
4. The voice guide will say "Password is enabled. Would you like to disable it?" Answer "Yes."
Answer "No" to cancel the disabling of the password and return to the main menu.
5. When the disabling of the password is completed, the voice guide will say "Password is disabled" and the system will return to the main menu.

Bluetooth® 2.0 interface*

Speaker enrollment function

E00727400209

The Bluetooth® 2.0 interface can use the speaker enrollment function to create a voice model for one person per language.

This makes it easier for the Bluetooth® 2.0 interface to recognise voice commands said by you.

You can turn a voice model registered with the speaker enrollment function on and off whenever you want.

8

Speaker enrollment

E00727501294

It takes about 2 to 3 minutes to complete the speaker enrollment process.

To ensure the best results, run through the process while in the driver's seat, in an environment that is as quiet as possible (when there is no rain or strong winds and the vehicle windows are closed). Please turn off your phone while in speaker enrollment to prevent interruption of the process.

Use the following procedure for speaker enrollment.

1. Stop your vehicle in a safe area, firmly apply the parking brake and push the electrical parking switch.

NOTE

- Speaker enrollment is not possible unless the vehicle is parked. Make sure you park the vehicle in a safe area before attempting speaker enrollment.

2. Press the SPEECH button.
3. Say "Voice training".
4. The voice guide will say "This operation must be performed in a quiet environment while the vehicle is stopped. See the owner's manual for the list of required training phrases. Press and release the SPEECH button when you are ready to begin. Press the HANG-UP button to cancel at any time". Press the SPEECH button to start the speaker enrollment process.

NOTE

- If you do not start the speaker enrollment process within 3 minutes of pressing the SPEECH button, the speaker enrollment function will time out. The voice guide will say "Speaker Enrollment has timed out". The system will then beep and the voice recognition mode will be deactivated.

5. The voice guide will prompt for phrase 1. Repeat the corresponding phrase lis-

ted in table "Enrollment commands" on page 8-71.

The system will register your voice and then move on to the registration of the next command. Continue the process until all phrases have been registered.

NOTE

- To repeat the most recent voice training command, press and release the SPEECH button.
- If you press the HANG-UP button anytime during the process, the system will beep and stop the speaker enrollment process.

6. When all enrollment commands have been read out, the voice guide will say "Speaker enrollment is complete". The system will then end the speaker enrollment process and return to the main menu.

NOTE

- Completing the speaker enrollment process will turn on the voice model automatically.
- The commands "Help" and "Cancel" will not work in this mode.

Enabling and disabling the voice model and retraining

E00727600096

You can turn a voice model registered with the speaker enrollment function on and off whenever you want.

You can also retrain the system.

Use the following procedure to perform these actions.

1. Press the SPEECH button.
2. Say “Voice training”.
3. If you have completed a speaker enrollment process once already, the voice guide will say either “Enrollment is enabled. Would you like to disable or retrain?” or “Enrollment is disabled. Would you like to enable or retrain?”
4. When enrollment is “enabled”, the voice model is on; when enrollment is “disabled”, the voice model is off. Say the command that fits your needs.

Say “Retrain” to start the speaker enrollment process and recreate a new voice model. (Refer to “Speaker enrollment” on page 8-56.)

Connecting the Bluetooth® 2.0 interface and Bluetooth® device

E00760601663

Before you can make or receive hands-free calls or play music using the Bluetooth® 2.0 interface function, you must pair the Bluetooth® device and Bluetooth® 2.0 interface.

NOTE

- Pairing is required only when the device is used for the first time. Once the device has been paired with the Bluetooth® 2.0 interface, all you need is to bring the device into the vehicle next time and the device will connect to the Bluetooth® 2.0 interface automatically (if supported by the device). The device must have Bluetooth® turned ON to connect.

Up to 7 Bluetooth® devices can be paired with the Bluetooth® 2.0 interface.

If multiple paired Bluetooth® devices are available in the vehicle, the cellular phone or music player most recently connected is automatically connected to the Bluetooth® 2.0 interface.

You can also change a Bluetooth® device to be connected.

To pair

To pair a Bluetooth® device with the Bluetooth® 2.0 interface, use either one of the following 2 methods (Type 1 or Type 2).

Pairing procedure - Type 1*

1. Stop your vehicle in a safe area, firmly apply the parking brake and push the electrical parking switch.

NOTE

- You cannot pair any Bluetooth® device with the Bluetooth® 2.0 interface unless the vehicle is parked. Before pairing a Bluetooth® device with the Bluetooth® 2.0 interface, confirm that the vehicle is parked in a safe location.

2. Press the SPEECH button.
3. Say “Setup”.
4. Say “Pairing Options.”
5. The voice guide will say “Select one of the following: pair, edit, delete, or list.” Say “Pair.”

Bluetooth® 2.0 interface*

NOTE

- If 7 devices have already been paired, the voice guide will say “Maximum devices paired” and then the system will end the pairing process. To register a new device, delete one device and then repeat the pairing process.
(Refer to “Selecting a device: Deleting a device” on page 8-60.)

6. The voice guide will say “Please say a 4-digit pairing code.” Say a 4-digit number.

8

When the confirmation function is on, the system will confirm whether the number said is acceptable. Answer “Yes.”

Answer “No” to return to pairing code selection.

NOTE

- Some Bluetooth® devices require a specific pairing code. Please refer to the device manual for pairing code requirements.

NOTE

- The pairing code entered here is only used for the Bluetooth® connection certification. It is any 4-digit number the user would like to select.
Remember the pairing code as it needs to be keyed into the Bluetooth® device later in the pairing process.
Depending on the connection settings of the Bluetooth® device, this code may have to be entered each time you connect the Bluetooth® device to the Bluetooth® 2.0 interface. For the default connection settings, refer to the instructions for the device.

7. The voice guide will say “Start pairing procedure on the device. See the device manual for instructions.” Enter in the Bluetooth® device the 4-digit number you have registered in Step 6.

NOTE

- According to the corresponding device to Bluetooth®, it might take a few minute to pair the Bluetooth® device with the Bluetooth® 2.0 interface.
- If the Bluetooth® 2.0 interface cannot recognize the Bluetooth® device, the voice guide will say “Pairing has timed out” and the pairing process will be cancelled.
Confirm that the device you are pairing supports Bluetooth®, and try pairing it again.

NOTE

- If you enter the wrong number, the voice guide will say “Pairing failed” and the pairing process will be cancelled.
Confirm the number is right, and try pairing it again.

8. The voice guide will say “Please say the name of the device after the beep.” You can assign a desired name for the Bluetooth® device and register it as a device tag. Say the name you want to register after the beep.

NOTE

- When the confirmation function is on, after repeating the device tag you have said, the voice guide will ask “Is this correct?” Answer “Yes.”
To change the device tag, answer “No” and then say the device tag again.

9. The voice guide will say “Pairing complete,” and the pairing process will end.

Pairing procedure - Type 2*

1. Stop your vehicle in a safe area, firmly apply the parking brake and push the electrical parking switch.

NOTE

- You cannot pair any Bluetooth® device with the Bluetooth® 2.0 interface unless the vehicle is parked. Before pairing a Bluetooth® device with the Bluetooth® 2.0 interface, confirm that the vehicle is parked in a safe location.

2. Press the SPEECH button.
3. Say “Pair Device.”

NOTE

- The following procedure (① to ③) can also be used instead of saying “Pair Device.” Replace this step 3 with the following procedure if you prefer.
 - ① Say “Setup.”
 - ② Say “Pairing Options.”
 - ③ The voice guide will say “Select one of the following: pair, edit, delete, list or set code.” Say “Pair.”
- If 7 devices have already been paired, the voice guide will say “Maximum devices paired” and then the system will end the pairing process. To register a new device, delete one device and then repeat the pairing process. (Refer to “Selecting a device: Deleting a device” on page 8-60.)

4. The voice guide will say “Start pairing procedure on the device. See the device

manual for instructions.” and then will say “The pairing code is <pairing code>.”

NOTE

- Some Bluetooth® devices require a specific pairing code. Please refer to the device manual for pairing code requirements and read the next section “If your device requires a specific pairing code” on page 8-60 to set the pairing code.
- The pairing code entered here is only used for the Bluetooth® connection certification. Depending on the connection settings of the Bluetooth® device, this code may have to be entered each time you connect the Bluetooth® device to the Bluetooth® 2.0 interface. For the default connection settings, refer to the instructions for the device.

5. Enter in the Bluetooth® device the 4-digit number that has been read out in Step 4.

NOTE

- According to the corresponding device to Bluetooth®, it might take a few minute to pair the Bluetooth® device with the Bluetooth® 2.0 interface.

NOTE

- If the Bluetooth® 2.0 interface cannot recognize the Bluetooth® device, the voice guide will say “Pairing has timed out” and the pairing process will be cancelled. Confirm that the device you are pairing supports Bluetooth®, and try pairing it again.
- If you enter the wrong number, the voice guide will say “Pairing failed” and the pairing process will be cancelled. Confirm the number is right, and try pairing it again. If your device requires a specific pairing code, you need to set the pairing code. Refer to the device manual for pairing code requirements and read the next section “If your device requires a specific pairing code” on page 8-60.

6. The voice guide will say “Please say the name of the device after the beep.” You can assign a desired name for the Bluetooth® device and register it as a device tag. Say the name you want to register after the beep.

NOTE

- When the confirmation function is on, after repeating the device tag you have said, the voice guide will ask “Is this correct?” Answer “Yes.” To change the device tag, answer “No” and then say the device tag again.

Bluetooth® 2.0 interface*

- The voice guide will say “Pairing Complete. Would you like to import the contacts from your mobile device now?” Answer “Yes,” and the voice guide will say “Please wait while the contacts are imported. This may take several minutes.” Answer “No” to end the pairing process.

If your device requires a specific pairing code

8

If your device requires a specific pairing code, you need to set the pairing code. Follow the procedures below.

- Press the SPEECH button.
- Say “Setup.”
- Say “Pairing Options.”
- Say “Set Code.”
- The voice guide will say “Do you want the pairing code to be random or fixed?” Say “Fixed.”
- The voice guide will say “Please say a 4-digit pairing code.” Say a 4-digit number.
- The voice guide will say “Pairing code set to <pairing code>.”

When the confirmation function is on, the system will confirm whether the number said is acceptable. Answer “Yes.”

Answer “No” to return to Step 6.

- The voice guide will say “Do you want to pair a device now?” Answer “Yes,” the system will proceed to Step 3 in the pairing process. Refer to the “Pairing procedure- Type 2.”

Selecting a device

E00760700104

If multiple paired Bluetooth® devices are available in the vehicle, the cellular phone or music player most recently connected is automatically connected to the Bluetooth® 2.0 interface.

You can connect to the other paired cellular phone or music player by following setting change procedures.

To select a cellular phone

- Press the SPEECH button.
- Say “Setup”.
- Say “Select phone.”
- After the voice guide says “Please say,” the numbers of the cellular phones and device tags of corresponding cellular phones will be read out in order, starting with the cellular phone that has been most recently connected. Say the number of the cellular phone that you want to connect to. When the confirmation function is on, the system will ask you again whether the phone that you want to connect to is

correct. Answer “Yes” to continue and connect to the cellular phone.

Answer “No,” and the voice guide will say “Please say.” Say the number of the phone that you want to connect to.

NOTE

- You can connect to a phone at any time by pressing the SPEECH button and saying the number, even before all of the paired numbers and device tags of corresponding cellular phones are read out by the system.

- The selected phone will be connected to the Bluetooth® 2.0 interface. The voice guide will say “<device tag> selected” and then the system will return to the main menu.

To select a music player

- Press the SPEECH button.
- Say “Setup”.
- Say “Select music player.”
- After the voice guide says “Please say,” the numbers of the music players and device tags of corresponding music players will be read out in order, starting with the music player that has been most recently connected. Say the number of the music player that you want to connect to.

When the confirmation function is on, the system will ask you again whether the music player that you want to connect to is correct. Answer “Yes” to continue and connect to the music player. Answer “No,” and the voice guide will say “Please say.” Say the number of the music player that you want to connect to.

NOTE

- You can connect to a music player at any time by pressing the SPEECH button and saying the number, even before all of the paired numbers and device tags of corresponding music players are read out by the system.

- The selected music player will be connected to the Bluetooth® 2.0 interface. The voice guide will say “<device tag> selected” and then the system will return to the main menu.

Deleting a device

Use the following procedure to delete a paired Bluetooth® device from the Bluetooth® 2.0 interface.

- Press the SPEECH button.
- Say “Setup”.
- Say “Pairing options.”

- The voice guide will say “Select one of the following: pair, edit, delete, or list.” Say “Delete.”
- After the voice guide says “Please say,” the numbers of the devices and device tags of corresponding devices will be read out in order, starting with the device that has been most recently connected. After it completes reading all pairs, the voice guide will say “or all.” Say the number of the device that you want to delete from the system. If you want to delete all paired phones from the system, say “All.”
- For confirmation purposes, the voice guide will say “Deleting <device tag> <number>. Is this correct?” or “Deleting all devices. Is this correct?” Answer “Yes” to delete the phone(s). Answer “No” to return to Step 4.
- The voice guide will say “Deleted,” and then the system will end the device deletion process.

NOTE

- If the device deletion process fails for some reason, the voice guide will say “Delete failed” and then the system will cancel deleting the device.

To check a paired Bluetooth® device

E00760800017

You can check a paired Bluetooth® device by following the steps below.

- Press the SPEECH button.
- Say “Setup”.
- Say “Pairing options.”
- The voice guide will say “Select one of the following: pair, edit, delete, or list.” Say “List.”
- The voice guide will read out device tags of corresponding devices in order, starting with the Bluetooth® device that has been connected most recently.
- After the device tags of all paired Bluetooth® devices have been read, the system will say “End of list, would you like to start from the beginning?” To hear the list again from the beginning, answer “Yes.” When you are done, answer “No” to return to the main menu.

Bluetooth® 2.0 interface*

NOTE

- If you press and release the SPEECH button and say “Continue” or “Previous” while the list is being read, the system will advance or rewind the list.
Say “Continue” to proceed to the device with the next highest number or “Previous” to return to the phone with the previous number.
- You can change the device tag by pressing and releasing the SPEECH button and then saying “Edit” while the list is being read.
- You can change the phone to be connected by pressing and releasing the SPEECH button and then saying “Select phone” while the list is being read.
- You can change the music player to be connected by pressing and releasing the SPEECH button and then saying “Select music player” while the list is being read.

Changing a device tag

E00760900018

You can change the device tag of a paired cellular phone or music player.

Follow the steps below to change a device tag.

1. Press the SPEECH button.
2. Say “Setup”.
3. Say “Pairing options.”
4. The voice guide will say “Select one of the following: pair, edit, delete, or list.” Say “Edit.”

5. The voice guide will say “Please say,” and read out the numbers of the Bluetooth® devices and device tags of corresponding devices in order, starting with the Bluetooth® that has been most recently connected.

After all paired device tags have been read, the voice guide will say “Which device, please?” Say the number of the device tag you want to change.

NOTE

- You can press and release the SPEECH button while the list is being read, and immediately say the number of the device tag you want to change.

6. The voice guide will say “New name, please.” Say the name you want to register as a new device tag.

When the confirmation function is on, the voice guide will say “<New device tag>. Is this correct?” Answer “Yes.”

Answer “No,” to say the new device tag you want to register again.

7. The device tag is changed.

When the change is complete, the voice guide will say “New name saved” and then the system will return to the main menu.

Operating a music player connected via Bluetooth®

E00761001462

For the operation of a music player connected via Bluetooth®, refer to “Listen to Bluetooth Audio” on page 8-40. On vehicles equipped with MITSUBISHI Multi-Communication System (MMCS), the Smartphone Link Display Audio or the DISPLAY AUDIO, refer to the separate owner’s manual.

How to make or receive hands-free calls

E00761100059

You can make or receive hands-free calls using a Bluetooth® compatible cellular phone connected to the Bluetooth® 2.0 interface.

You can also use the phone books in the Bluetooth® 2.0 interface to make calls without dialling telephone numbers.

“To make a call” on page 8-63

“SEND function” on page 8-64

“Receiving calls” on page 8-64

“MUTE function” on page 8-64

“Switching between hands-free mode and private mode” on page 8-65

NOTE

- The hands-free calls might not be operated correctly when it makes calling or receiving by operating the cellular phone directly.

To make a call

E00761200148

You can make a call in the following 3 ways using the Bluetooth® 2.0 interface:

Making a call by saying a telephone number, making a call using the Bluetooth® 2.0 interface's phone book, and making a call by redialing.

Making a call by using the telephone number

You can make a call by saying the telephone number.

1. Press the SPEECH button.
2. Say "Dial."
3. After the voice guide says "Number please," say the telephone number.
4. The voice guide will say "Dialing <number recognised>."

The Bluetooth® 2.0 interface will then make the call.

When the confirmation function is on, the system will confirm again the telephone number. To continue with that number, answer "Yes."

To change the telephone number, answer "No." The system will say "Number

please" then say the telephone number again.

NOTE

- In the case of English, the system will recognise both "zero" and "oh" (Letter "o") for the number "0."
- The Bluetooth® 2.0 interface supports numbers (0 to 9) and characters (+, # and*).
- The maximum supported telephone number length is as follows:
 - International telephone number: + and telephone numbers (to 18 digits).
 - Except for international telephone number: telephone numbers (to 19 digits).

Making a call using a phone book

You can make calls using the vehicle phone book or mobile phone book of the Bluetooth® 2.0 interface.

For details on the phone books, refer to "Phone book function" on page 8-65.

1. Press the SPEECH button.
2. Say "Call."

NOTE

- If you say "Call" when the vehicle phone book and the mobile phone book are empty, the voice guide will say "The vehicle phone book is empty. Would you like to add a new entry now?"
Answer "Yes," and the voice guide will say "Entering the phone book - new entry menu." You can now create data in the vehicle phone book.
Answer "No," to return to the main menu.

3. After the voice guide says "Name please," say the name you want to call, from those registered in the phone book.

4. If there is only one match, the system proceeds to Step 5.

If there are two or more matches, the voice guide will say "More than one match was found, would you like to call <returned name>." If that person is the one you want to call, answer "Yes."

Answer "No," and the name of the next matching person will be uttered by the voice guide.

NOTE

- If you say "No" to all names read by the system, the voice guide will say "Name not found, returning to main menu" and the system will return to the main menu.

Bluetooth® 2.0 interface*

5. If only one telephone number is registered under the name you just said, the voice guide proceeds to Step 6.

If two or more telephone numbers are registered that match the name you just said, the voice guide will say “Would you like to call <name> at [home], [work], [mobile], or [other]?” Select the location to call.

NOTE

8

- If the name you selected has matching data in the vehicle phone book but no telephone number is registered under the selected location, the voice guide will say “{home/work/mobile/other} not found for <name>. Would you like to add location or try again?” Say “Try again,” and the system will return to Step 3. Say “Add location” and you can register an additional telephone number under the selected location.
- If the name you selected has matching data in the mobile phone book but no telephone number is registered under the selected location, the voice guide will say “{home/work/mobile/other} not found for <name>. Would you like to try again?” Answer “Yes,” and the system will return to Step 3. Answer “No,” and the call will be cancelled. Start over again from Step 1.

6. The voice guide will say “Calling <name> <location>” and then the system will dial the telephone number.

NOTE

- When the confirmation function is on, the system will ask if the name and location of the receiver are correct. If the name is correct, answer “Yes.” To change the name or location to call, answer “No.” The system will return to Step 3.

Redialing

You can redial the last number called, based on the history of dialed calls in the paired cellular phone.

Use the following procedure to redial.

1. Press the SPEECH button.
2. Say “Redial.”

SEND function

E00761300035

During a call, press the SPEECH button to enter voice recognition mode, then say “<numbers> SEND” to generate DTMF tones.

For example, if during a call you need to simulate the press of a phone button as a response to an automated system, press the SPEECH button and speak “1 2 3 4 pound SEND” and the 1234# will be sent on your cellular phone.

Receiving calls

E00761601064

If an incoming phone call is received while the operation mode is in ON or ACC, the audio system will be automatically turned on and switched to the incoming call, even when the audio system was originally off.

The voice guide announcement for the incoming call will be output from the front passenger’s seat speaker.

If the CD player or radio was playing when the incoming call was received, the audio system will mute the sound from the CD player or radio and output only the incoming call.

To receive the call, press the PICK-UP button on the steering wheel control switch.

When the call is over, the audio system will return to its previous state.

MUTE function

E00760300041

At any time during a call, you can mute the vehicle microphone.

Pressing the SPEECH button and then saying “Mute” during a call will turn ON the MUTE function and mute the microphone.

Saying “Mute off” in the same way will turn off the MUTE function and cancel the mute on the microphone.

Switching between hands-free mode and private mode

E00761400036

The Bluetooth® 2.0 interface can switch between Hands-free mode (Hands-free calls) and private mode (calls using cellular phone). If you press the SPEECH button and say “Transfer call” during a Hands-free call, you can stop the Hands-free mode and talk in private mode.

To return to Hands-free mode, press the SPEECH button again and say “Transfer call”.

Phone book function

E00763700017

The Bluetooth® 2.0 interface has 2 types of unique phone books that are different from the phone book stored in the cellular phone. They are the vehicle phone book and the mobile phone book.

These phone books are used to register telephone numbers and to make calls to desired numbers via the voice recognition function.

NOTE

- Disconnecting the battery cable will not delete information registered in the phone book.

Vehicle phone book

E00763801262

This phone book is used when making calls with the voice recognition function.

Up to 32 names can be registered in the vehicle phone book per language.

Also, each entry has 4 locations associated with: home, work, mobile and other. You can register one telephone number for each location.

You can register a desired name as a name for any phone book entry registered in the vehicle phone book.

Names and telephone numbers can be changed later on.

The vehicle phone book can be used with all paired cellular phones.

To register a telephone number in the vehicle phone book

You can register a telephone number in the vehicle phone book in the following 2 ways: Reading out a telephone number, and selecting and transferring 1 phone book entry from the phone book of the cellular phone.

To register by reading out a telephone number

1. Press the SPEECH button.
2. Say “Phone book.”

3. The voice guide will say “Select one of the following: new entry, edit number, edit name, list names, delete, erase all, or import contact.” Say “New entry.”
4. The voice guide will say “Name please.” Say your preferred name to register it.

NOTE

- If the maximum number of entries are already registered, the voice guide will say “The phone book is full. Would you like to delete a name?” Say “Yes” if you want to delete a registered name. Say “No,” to return to the main menu.

5. When the name has been registered, the voice guide will say “home, work, mobile, or other?” Say the location for which you want to register a telephone number.

NOTE

- When the confirmation function is on, the voice guide will say “<Location>. Is this correct?” Answer “Yes.” If a telephone number has been registered for the selected location, the voice guide will say “The current number is <telephone number>, number please.” If you do not want to change the telephone number, say “cancel” or the original number to keep it registered.

Bluetooth® 2.0 interface*

- The voice guide will say “Number please.” Say the telephone number to register it.

NOTE

- In the case of English, the system will recognise both “zero” and “oh” (Letter “o”) for the number “0.”

- The voice guide will repeat the telephone number you have just read, and then register the number.

8

When the telephone number has been registered, the voice guide will say “Number saved. Would you like to add another number for this entry?”

To add another telephone number for a new location for the current entry, answer “Yes.” The system will return to location selection in Step 5.

Answer “No” to end the registration process and return to the main menu.

NOTE

- When the confirmation function is on, after repeating the telephone number you have read, the voice guide will ask “Is this correct?” Answer “Yes.”
Answer “No” to return to telephone number registration in step 6.

To select and transfer one phone book entry from the phone book of the cellular phone

You can select 1 phone book entry from the phone book of the cellular phone and register it in the vehicle phone book.

NOTE

- Transfer is not permitted unless the vehicle is parked. Before transferring, make sure that the vehicle is parked in a safe location.
- All or part of data may not be transferred, even when the cellular phone supports Bluetooth®, depending on the compatibility of the device.
- The maximum supported telephone number length is 19 digits. Any telephone number of 20 digits or more will be truncated to the first 19 digits.
- If telephone numbers contain characters other than 0 to 9, *, # or +, these characters are deleted before the transfer.
- For the connection settings on the cellular phone side, refer to the instructions for the cellular phone.

- Press the SPEECH button.
- Say “Phone book.”
- The voice guide will say “Select one of the following: new entry, edit number, edit name, list names, delete, erase all, or import contact.” Say “Import contact.”

- The voice guide will say “Would you like to import a single entry or all contacts?” Say “Single entry.”

The Bluetooth® 2.0 interface will become ready to receive transferred phone book data.

NOTE

- If the maximum number of entries are already registered, the voice guide will say “The phone book is full. Would you like to delete a name?” Say “Yes” if you want to delete a registered name.
Say “No,” to return to the main menu.

- After the voice guide says “Ready to receive a contact from the phone. Only a home, a work, and a mobile number can be imported,” the Bluetooth® 2.0 interface will receive the phone book data from the Bluetooth® compatible cellular phone.
- Operate the Bluetooth® compatible cellular phone to set it up so that the phone book entry you want to register in the vehicle phone book can be transferred to the Bluetooth® 2.0 interface.

 **NOTE**

- If the Bluetooth® 2.0 interface cannot recognise the Bluetooth® compatible cellular phone or the connection takes too much time, the voice guide will say “Import contact has timed out” and then the system will cancel the registration. In such case, start over again from Step 1.
- Pressing the HANG-UP button or pressing and holding the SPEECH button will cancel the registration.

7. When the reception is complete, the voice guide will say “<Number of telephone numbers that had been registered in the import source> numbers have been imported. What name would you like to use for these numbers?”
Say the name you want to register for this phone book entry.

 **NOTE**

- If the entered name is already used for other phone book entry or similar to a name used for other phone book entry, that name cannot be registered.

8. The voice guide will say “Adding <name>.”

When the confirmation function is on, the system will ask if the name is correct. Answer “Yes.”

Answer “No,” and the voice guide will say “Name please.” Register a different name.

9. The voice guide will say “Numbers saved.”
10. The voice guide will say “Would you like to import another contact?”

Answer “Yes” if you want to continue with the registration. You can continue to register a new phone book entry from Step 5.

Answer “No,” to return to the main menu.

To change the content registered in the vehicle phone book

E00739800024

You can change or delete a name or telephone number registered in the vehicle phone book.

You can also listen to the list of names registered in the vehicle phone book.

 **NOTE**

- The system must have at least one entry.

Editing a telephone number

1. Press the SPEECH button.
2. Say “Phone book.”
3. The voice guide will say “Select one of the following: new entry, edit number, edit name, list names, delete, erase all, or import contact.” Say “Edit number.”
4. The voice guide will say “Please say the name of the entry you would like to edit, or say list names.” Say the name of the phone book entry you want to edit.

 **NOTE**

- Say “List names,” and the names registered in the phone book will be read out in order. Refer to “Listening to the list of registered names” on page 8-68.

5. The voice guide will say “Home, work, mobile or other?” Select and say the location where the telephone number you want to change or add is registered.

When the confirmation function is on, the system will check the target name and location again. Answer “Yes” if you want to continue with the editing.

Answer “No” to return to Step 3.

6. The voice guide will say “Number please.” Say the telephone number you want to register.

Bluetooth® 2.0 interface*

NOTE

- If the telephone number is already registered in the selected location, the voice guide will say “The current number is <current number>. New number, please.” Say a new telephone number to change the current number.

7. The voice guide will repeat the telephone number.
When the confirmation function is on, the system will ask if the number is correct. Answer “Yes.”
Answer “No” to return to Step 3.
8. Once the telephone number is registered, the voice guide will say “Number saved” and then the system will return to the main menu.

NOTE

- If the location where a telephone number was already registered has been overwritten with a new number, the voice guide will say “Number changed” and then the system will return to the main menu.

Editing a name

1. Press the SPEECH button.
2. Say “Phone book.”
3. The voice guide will say “Select one of the following: new entry, edit number, edit name, list names, delete, erase all, or import contact.” Say “Edit name.”

4. The voice guide will say “Please say the name of the entry you would like to edit, or say list names.” Say the name you want to edit.

NOTE

- Say “List names,” and the names registered in the phone book will be read out in order. Refer to “Listening to the list of registered names” on page 8-68.

5. The voice guide will say “Changing <name>.”
When the confirmation function is on, the system will ask if the name is correct. Answer “Yes” if you want to continue with the editing based on this information.
Answer “No” to return to Step 4.
6. The voice guide will say “Name please.”
Say the new name you want to register.
7. The registered name will be changed.
When the change is complete, the system will return to the main menu.

■ Listening to the list of registered names

E00739900025

1. Press the SPEECH button.
2. Say “Phone book.”

3. The voice guide will say “Select one of the following: new entry, edit number, edit name, list names, delete, erase all, or import contact.” Say “List names.”
4. Bluetooth® 2.0 interface will read out the entries in the phone book in order.
5. When the voice guide is done reading the list, it will say “End of list, would you like to start from the beginning?”
When you want to check the list again from the beginning, answer “Yes.”
When you are done, answer “No” to return to the previous or main menu.

NOTE

- You can call, edit or delete a name that is being read out.
Press the SPEECH button and say “Call” to call the name, “Edit name” to edit it, or “Delete” to delete it.
The system will beep and then execute your command.
- If you press the SPEECH button and say “Continue” or “Previous” while the list is being read, the system will advance or rewind the list. Say “Continue” to proceed to the next entry or “Previous” to return to the previous entry.

■ Deleting a telephone number

E00740000026

1. Press the SPEECH button.
2. Say “Phone book.”

3. The voice guide will say “Select one of the following: new entry, edit number, edit name, list names, delete, erase all, or import contact.” Say “Delete.”
4. The voice guide will say “Please say the name of the entry you would like to delete, or say list names.” Say the name of the phone book entry in which the telephone number you want to delete is registered.

NOTE

- Say “List names,” and the names registered in the phone book will be read out in order. Refer to “Listening to the list of registered names” on page 8-68.

5. If only one telephone number is registered in the selected phone book entry, the voice guide will say “Deleting <name> <location>.”
If multiple telephone numbers are registered in the selected phone book entry, the voice guide will say “Would you like to delete [home], [work], [mobile], [other], or all?”
Select the location to delete, and the voice guide will say “Deleting <name> <location>.”

NOTE

- To delete the telephone numbers from all locations, say “All.”

6. The system will ask if you really want to delete the selected telephone number(s) to go ahead with the deletion, answer “Yes.”
Answer “No,” the system will cancel deleting the telephone number(s) and then return to Step 4.
7. When the deletion of the telephone number is completed, the voice guide will say “<name> <location> deleted” and then the system will return to the main menu.
If all locations are deleted, the system will say “<name> and all locations deleted” and the name will be removed from the phone book. If numbers still remain under the entry, the name will retain the other associated numbers.

Erasing the phone book

E00740100027

You can delete all registered information from the vehicle phone book.

1. Press the SPEECH button.
2. Say “Phone book.”

3. The voice guide will say “Select one of the following: new entry, edit number, edit name, list names, delete, erase all, or import contact.” Say “Erase all.”
4. For confirmation purposes, the voice guide will ask “Are you sure you want to erase everything from your hands-free system phone book?” Answer “Yes.”
Answer “No” to cancel the deletion of all registered information in the phone book and return to the main menu.
5. The voice guide will say “You are about to delete everything from your hands-free system phone book. Do you want to continue?” Answer “Yes” to continue.
Answer “No” to cancel the deletion of all registered information in the phone book and return to the main menu.
6. The voice guide will say “Please wait, erasing the handsfree system phone book” and then the system will delete all data in the phone book.
When the deletion is complete, the voice guide will say “Hands-free system phone book erased” and then the system will return to the main menu.

Mobile phone book

E00763900080

All entries in the phone book stored in the cellular phone can be transferred in a batch and registered in the mobile phone book.

Bluetooth® 2.0 interface*

Up to 7 mobile phone books, each containing up to 1,000 names, can be registered.

The Bluetooth® 2.0 interface automatically converts from text to voice the names registered in the transferred phone book entries, and creates names.

NOTE

- Only the mobile phone book transferred from the connected cellular phone can be used with that cellular phone.
- You cannot change the names and telephone numbers in the phone book entries registered in the mobile phone book. You cannot select and delete specific phone book entries, either. To change or delete any of the above, change the applicable information in the source phone book of the cellular phone and then transfer the phone book again.

To import a devices phone book

Follow the steps below to transfer to the mobile phone book the phone book stored in the cellular phone.

NOTE

- Transfer should be completed while the vehicle is parked. Before transferring, make sure that the vehicle is parked in a safe location.

NOTE

- The already stored phone book in the mobile phone book is overwritten by the stored phone book in the cellular phone.
- All or part of data may not be transferred, even when the cellular phone supports Bluetooth®, depending on the compatibility of the device.
- Only a home, a work, and a mobile number can be imported.
- The maximum supported telephone number length is 19 digits. Any telephone number of 20 digits or more will be truncated to the first 19 digits.
- If telephone numbers contain characters other than 0 to 9, *, # or +, these characters are deleted before the transfer.
- For the connection settings on the cellular phone side, refer to the instructions for the cellular phone.

1. Press the SPEECH button.
2. Say “Phone book.”
3. The voice guide will say “Select one of the following: new entry, edit number, edit name, list names, delete, erase all, or import contact.” Say “Import contact.”
4. The voice guide will say “Would you like to import a single entry or all contacts?” Say “All contacts.”
5. The voice guide will say “Importing the contact list from the mobile phone book. This may take several minutes to complete. Would you like to continue?” An-

swer “Yes,” transferring to the mobile phone book the phone book stored in the cellular phone will start.

Answer “No,” to return to the main menu.

NOTE

- The transfer may take some time to complete depending on the number of contacts.
- If the Bluetooth® 2.0 interface could not be connected to the Bluetooth® compatible cellular phone, the voice guide will say “Unable to transfer contact list from phone” and then the system will return to the main menu.
- If you press the HANG-UP button or press and hold the SPEECH button during the data transfer, the transfer will be cancelled and the system will return to the main menu.
- If an error occurs during the data transfer, all transfer will be cancelled and the voice guide will say “Unable to complete the phone book import” and then the system will return to the main menu.
- If there are no contacts in the phone book, the voice guide will say “There are no contacts on the connected phone.”

6. When the transfer is complete, the voice guide will say “Import complete” and then the system will return to the main menu.

Enrollment commands

E00732401480

Phrase	English	French	Spanish	Italian	German	Dutch	Portuguese	Russian
1	0123456789	0123456789	0123456789	0123456789	0123456789	0123456789	0123456789	0123456789
2	888 555 1212	888 555 1212	888 555 1212	888 555 1212	888 555 1212	888 555 1212	888 555 1212	888 555 1212
3	Call	Appeler	Llamar	Chiama	Anrufen	Bellen	Ligar	Вызов
4	Dial	Composer	Marcar	Componi	Wählen	Nummer keuze	Marcar	Набор
5	Setup	Configurer	Configuración	Configura	Einrichtung	Setup	Configurar	Настройка
6	Cancel	Annuler	Cancelar	Annulla	Abbrechen	Annuleren	Cancelar	Отмена
7	Continue	Continuer	Continuar	Continua	Weiter	Doorgaan	Continuar	Продолжить
8	Help	Aide	Ayuda	Aiuto	Hilfe	Help	Ajuda	Справка

USB input terminal*

E00761901878

You can connect your USB memory device or iPod* to play music files stored in the USB memory device or iPod.

*: “iPod” is a registered trademark of Apple Inc. in the United States and other countries. This section explains how to connect and remove a USB memory device or iPod. See the following section for details on how to play music files.

Refer to “Listen to an iPod” on page 8-33.

Refer to “Listen to Audio Files on a USB Device” on page 8-35.

Refer to “To play iPod/USB memory device tracks via voice operation” on page 8-37.

USB input terminal locations

E00778600056

The USB input terminal (A) is located in the illustrated positions.

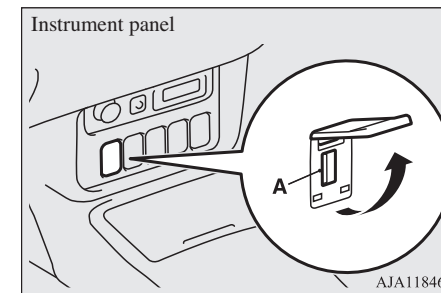

AJA118466

For pleasant driving 8-71

USB input terminal*

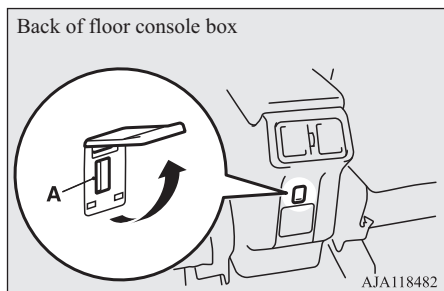

8

How to connect a USB memory device

E00762001906

1. Park your vehicle in a safe place and put the operation mode in OFF.
2. Open the USB input terminal cover.
3. Connect a commercially available USB connector cable (A) to the USB memory device (B).

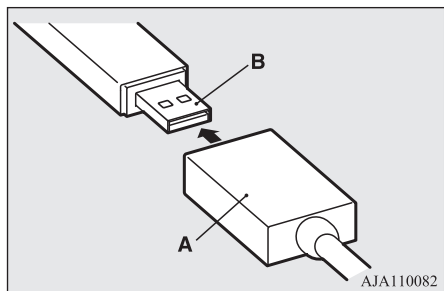

8-72 For pleasant driving

4. Connect the USB connector cable to the USB input terminal.

NOTE

- Do not connect the USB memory device to the USB input terminal directly. The USB memory device may be damaged.

5. To remove the USB connector cable, put the operation mode in OFF first and perform the installation steps in reverse.

How to connect an iPod

E00762101923

1. Park your vehicle in a safe place and put the operation mode in OFF.
2. Open the USB input terminal cover.
3. Connect the connector cable to the iPod.

NOTE

- Use a genuine connector cable from Apple Inc.

4. Connect the connector cable to the USB input terminal.
5. To remove the connector cable, put the operation mode in OFF first and perform the installation steps in reverse.

OGGE19E1

Types of connectable devices and supported file specifications

E00762201399

Except for vehicles equipped with the Bluetooth® 2.0 interface

For details about the types of connectable devices and supported file specifications, refer to the following pages and manuals.

[For vehicles equipped with the LW/MW/FM radio/CD player]

Refer to “Listen to an iPod” on page 8-33, “Listen to Audio Files on a USB Device” on page 8-35 and “Audio Files (MP3/WMA/AAC)” on page 8-21.

[For vehicles equipped with the MITSUBISHI Multi-Communication System (MMCS), the Smartphone Link Display Audio or the DISPLAY AUDIO]

Refer to the separate owner’s manual.

For vehicles equipped with the Bluetooth® 2.0 interface

For details about the types of connectable devices and supported file specifications, refer to the following section.

Device types

E00762301723

Devices of the following types can be connected.

Sun visors

Model name	Condition
USB memory device	Storage capacity of 256 Mbytes or more (File System is FAT16/32)
Models other than USB memory devices and iPods	Digital audio player supporting mass storage class

For connectable device type for “iPod*,” “iPod classic*,” “iPod nano*,” “iPod touch*” and “iPhone*,” access the MITSUBISHI MOTORS website.

Please read and agree to the “Warning about Links to the Web Sites of Other Companies”. The websites mentioned above may connect you to websites other than the MITSUBISHI MOTORS website.

<http://www.mitsubishi-motors.com/en/products/index.html>

 NOTE
<ul style="list-style-type: none"> Depending on the type of the USB memory device or other device connected, the connected device may not function properly or the available functions may be limited.

*“iPod”, “iPod classic”, “iPod nano”, “iPod touch” and “iPhone” are registered trademarks of Apple Inc. in the United States and other countries.

NOTE

- It is recommended to use an iPod with firmware updated to the latest version.
- You can charge your iPod by connecting it to the USB input terminal when the operation mode is in ON or ACC.
- Do not keep your USB memory device or iPod in your vehicle.
- It is recommended that you back up files in case of data damage.
- Do not connect to the USB input terminal any device (hard disk, card reader, memory reader, etc.) other than the connectable devices specified in the previous section. The device and/or data may be damaged. If any of these devices was connected by mistake, remove it after putting the operation mode in OFF.

File specifications

E00762401056

You can play music files of the following specifications that are saved in a USB memory device or other device supporting mass storage class. When you connect your iPod, playable file specifications depend on the connected iPod.

Item	Condition
File format	MP3, WMA, AAC, WAV

Item	Condition
Maximum number of levels (including the root)	Level 8
Number of folders	700
Number of files	65,535

Sun visors

E00711202277

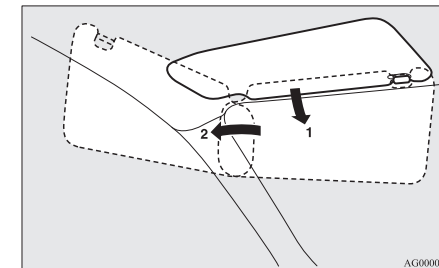

8

- To eliminate front glare
- To eliminate side glare

Vanity mirror

A vanity mirror is fitted to the back of the sun visor.

Ashtray*

Operating the lid of the vanity mirror will automatically turn on the mirror lamp (A).

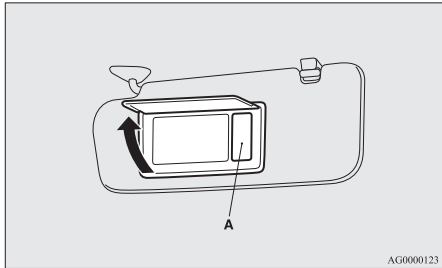

8

CAUTION

- If the lid of vanity mirror with lamp is kept open for prolonged periods of time, the auxiliary battery will be discharged.

Card holder

Cards can be slipped into the holder (B) on the back of the sun visor.

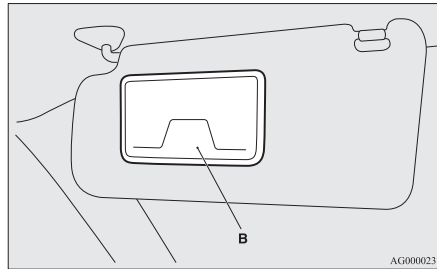

Ashtray*

E00711401100

CAUTION

- Put out matches and cigarettes before they are placed in the ashtray.
- Don't put papers and other things that burn into your ashtrays. If you do, cigarettes or other smoking materials could set them on fire, causing damage.
- Always close the ashtray. If left open, other cigarette butts in the ashtray may be rekindled.

To use the ashtray, open the lid.

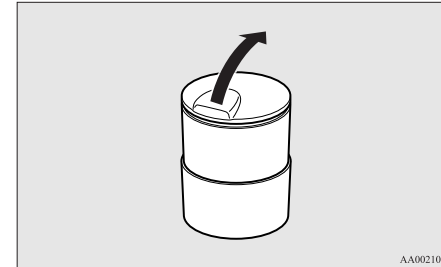

Mounting position for moveable ashtray

The moveable ashtray can be fitted at the indicated position.



Cigarette lighter*

E00711502759

The cigarette lighter can be used while the operation mode is in ON or ACC.

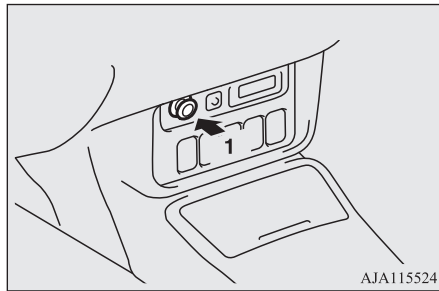

AJA115524

1- Push all the way in.

The cigarette lighter will automatically return to its original position with a “click” when ready. Pull it out for use.

After use, insert the cigarette lighter to its original position in the socket.

NOTE

- Do not leave the cigarette lighter removed from its socket, because the socket might become clogged by foreign material and be short-circuited.

CAUTION

- Do not touch the heating element or the cigarette lighter housing, hold the knob only to prevent burns.
- Do not allow children to operate or play with the cigarette lighter as burns may occur.
- Something is wrong with the cigarette lighter if it does not pop back out within approximately 30 seconds of being pushed in. Pull it out and have the problem corrected at MITSUBISHI MOTORS Authorized Service Point.
- Do not use any electric appliance that is not approved by MITSUBISHI MOTORS. Doing so could damage the socket. If you used the cigarette lighter after damaging the socket, the cigarette lighter might pop out or fail to come out after being pushed in.
- When the cigarette lighter socket is used as a power source for an electric appliance, be sure that the electric appliance operates at 12 V and has an electric capacity of 120 W or less. In addition, long use of the electric appliance when the ready indicator is not illuminated may run down the auxiliary battery.

Accessory socket*

E00711603207

CAUTION

- Be sure to use a “plug-in” type accessory operating at 12 V and at 120 W or less. When using the two sockets at the same time, make sure that the electrical accessories are 12 V accessories and that the total power consumption does not exceed 120 W.
- Long use of the electric appliance when the ready indicator is not illuminated may run down the auxiliary battery.
- When the accessory socket is not in use, be sure to close the lid or install the cap, because the socket might become clogged by foreign material and be short-circuited.

To use a plug-in type accessory, open the lid or remove the cap, and insert the plug in the accessory socket.

220-240 V AC power supplies*

The accessory socket can be used while the operation mode is in ON or ACC.

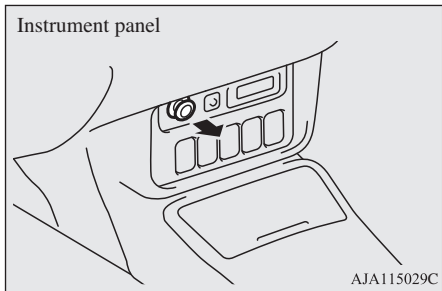

8

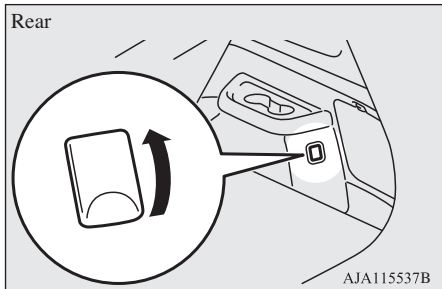

220-240 V AC power supplies*

E00749300093

220-240 V AC power supply can be used as a power source of household appliances when the ready indicator illuminates.

8-76 For pleasant driving

CAUTION

- Be sure to use a “plug-in” type accessory operating at 230 V and at 1500 W or less. When using more than one socket at the same time, make sure that the total power consumption of the electrical appliances does not exceed 1500 W at 230 V.

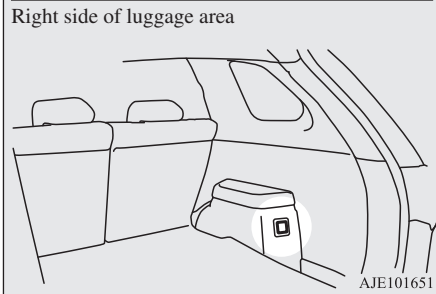
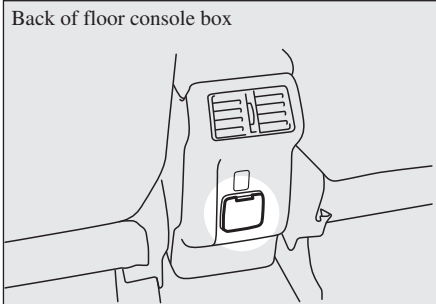

To use

1. Press the 220-240 V AC power supply switch. The indication lamp (A) will come on and the power supply system is ready for use. To cancel power supply, press the switch again and the indication lamp will go off.

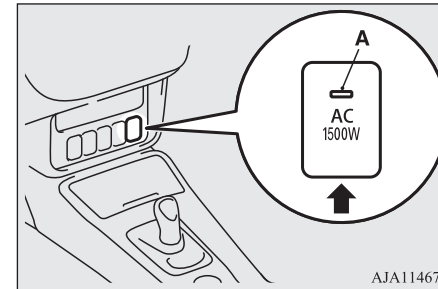

2. Open the lid (B).

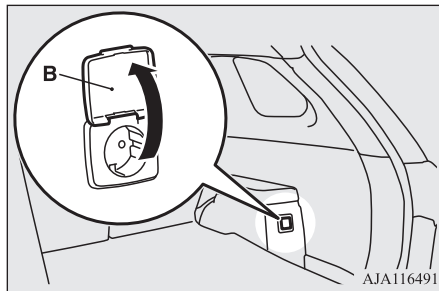
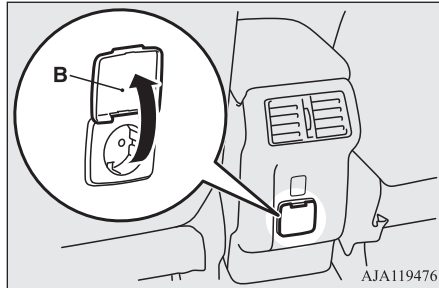

3. Insert the plug in the power outlet firmly. Make sure that the plug is connected correctly.
4. Disconnect the plug and close the lid after using the electrical appliance.

⚠ WARNING

- Never use the 220-240 V AC power supply to charge an electric vehicle or a plug-in hybrid vehicle. Also, never connect the 220-240 V AC power supply to a household powerline or a distribution panel. This may lead to an electric shock or a malfunction.
- Do not connect or disconnect the plug with a wet hand. Doing so can cause an electric shock.
- Never pull the cable to remove the plug. Pull straight while holding the plug of an electrical appliance.
- Do not disassemble or modify the 220-240 V AC power supply.
- When using electrical appliance while driving, make sure that it is firmly secured. Flying objects entering the passenger compartment during sudden braking or sharp turning could result in a serious accident and/or injury. Refer to “Luggage hooks” on page 8-87.
- Do not use an electrical appliance which emits steam while the windows are closed. Lack of visibility due to steam could lead to an accident.
- While using the 220-240 V AC power supply, even if the engine is not running, the engine may automatically start later depending on the condition of the Plug-in Hybrid EV system and/or the drive battery.

⚠ WARNING

- Before using the 220-240 V AC power supply while the vehicle is stationary, to prevent the vehicle from moving abruptly, apply the parking brake firmly and press the electrical parking switch and make sure that the select position indicator on the multi-information displays “P” (PARK). Also, to avoid activating the selector lever, do not place a power cord on or near the lever.
- Never use the 220-240 V AC power supply in a closed or poorly ventilated area, such as in a garage or an area surrounded by snow banks. Carbon monoxide gas, which is odorless and extremely poisonous, could build up and cause serious injury or death.
- When using the 220-240 V AC power supply while it is raining or snowing, do not leave the door or tailgate open. Wetting the 220-240 V AC power supply may cause overheating resulting in a fire and/or electrical shock.
- Never use a multi-plug adapter or conversion adapter. Using them may cause overheating resulting in fire.
- If you use an electrical appliance that emits light, your visibility at night may be affected which could impede safe driving.
- Do not spill a beverage on the 220-240 V AC power supply. This may cause overheating resulting in a fire and/or electrical shock.

220-240 V AC power supplies*

WARNING

- Do not let children touch the 220-240 V AC power supply.
- The cooling fan in the engine compartment may automatically operate when using the 220-240 V AC power supply. Keep your hands and clothes away from the cooling fan.
- Never use the 220-240 V AC power supply when lightning or thunder is observed or expected.
- Never use the 220-240 V AC power supply for electromedical apparatus.

8

CAUTION

- When the 220-240 V AC power supply is not in use, be sure to cancel power supply by pressing the 220-240 V AC power supply switch, disconnect the plug and close the lid. This will prevent the 220-240 V AC power supply from becoming clogged and short-circuiting.
- Do not stand behind the exhaust pipe as the engine may automatically start depending on the condition. Heat from the exhaust could lead to burns.
- Make sure that the plug is inserted all the way into the 220-240 V AC power supply before using an electrical appliance.
- Do not use an electrical appliance in the vehicle which emits heat such as a heater. Heat damage to interior parts could result.

CAUTION

- Do not connect a malfunctioning electrical appliance to the 220-240 V AC power supply. Doing so could damage the 220-240 V AC power supply.

NOTE

- The accessory socket and 220-240 V AC power supplies can be used simultaneously. Refer to “Accessory socket*” on page 8-75.
- If the plug of the electrical appliance was loose or wobbled when inserted in the outlet, have the 220-240 V AC power supply replaced at a MITSUBISHI MOTORS Authorized Service Point.
- Never leave the vehicle, perform refueling or washing the vehicle while using the 220-240 V AC power supply.
- You may hear operating sounds such as sounds from the cooling fan near the luggage area when using the 220-240 V AC power supply. This is normal.
- Never use electrical appliance that is vulnerable to vibration or heat in the cabin. When exposed to strong direct sunlight, the cabin will become extremely hot. It could cause product failure.
- Do not use the 220-240 V AC power supply with the vehicle covered by a car cover.
- When closing the window, door or tailgate, be careful not to trap the power supply cord.
- 220-240 V AC power supply cannot be used in the following cases.

NOTE

- When the Plug-in Hybrid EV System warning lamp is illuminated.
- When the drive battery level display indicates 0.
- When the “PROPULSION POWER IS REDUCED” warning display appears.
- Electrical appliance may not operate normally or electricity supply stops under the following conditions. You may hear an operation noise. This is normal.
 - When the power consumption of the electrical appliance exceeds 1500 W.
 - When the vehicle interior temperature is too hot or too cold.
- When the 220-240 V AC power supply cannot be used or is not returned to operation automatically after stopping electricity supply, follow the procedures below.
 - 1 Disconnect the plug of electrical appliance.
 - 2 Confirm the remaining quantity of the drive battery. When it is low, charge the drive battery by using the battery SAVE/CHARGE mode switch, etc.
“Battery SAVE/CHARGE mode switch” on page 7-28
Normal charging (charging method with rated AC 220-240V outlet) → p. 3-10
Quick charging (charging method with quick charger) → p. 3-17

NOTE

3 Confirm that the ready indicator illuminates. If not, start the Plug-in Hybrid EV System.

4 When the vehicle interior temperature is too hot or too cold, adjust it appropriately by using the air conditioner.

5 Press the 220-240 V AC power supply switch to turn it on.

6 Confirm that the indication lamp on the 220-240 V AC power supply switch comes on and insert the plug in the power outlet.

- The following electrical appliance may not operate normally even if the power consumption is less than 1500 W. Also be aware that the electric power that can be used will vary depending on the drive battery condition.
 - Electrical appliance to which large amounts of current flow momentarily
 - Electrical appliance that gauges precise data
 - Electrical appliance that does not operate normally when it is not placed horizontally
 - Electrical appliance that needs extremely stable operation
 - Electrical appliance with a timer function, that needs the consecutive output

NOTE

- The AC power output may shut off and the electrical appliance may be turned off accordingly depending on the drive battery condition even if the battery level display does not indicate 0.
- The use of electrical appliance could cause radio or television noise.
- The voltage of the 220-240 V AC power supply cannot be correctly gauged with a commercially available tester. Consult a MITSUBISHI MOTORS Authorized Service Point when you need measurement of the voltage.
- Also refer to the instruction manual and label accompanying the electrical appliance.
- When the remaining power in the drive battery is low, the engine starts and charges the drive battery automatically. Be careful not to run out of fuel since it will be consumed when the engine starts.

Interior lamps

E00712002810

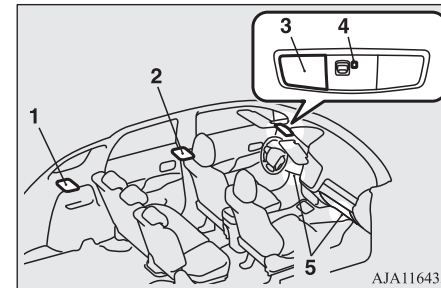

8

- 1- Luggage room lamp
- 2- Room lamp (rear)
- 3- Map & room lamps (front)
- 4- Downlight → p. 8-81
- 5- Front foot lamps

NOTE

- If you leave the lamps on when the ready indicator is not illuminated, you will run down the auxiliary battery. Before you leave the vehicle, make sure that the lamps are turned off.

Interior lamps

Room lamps

E00712102589

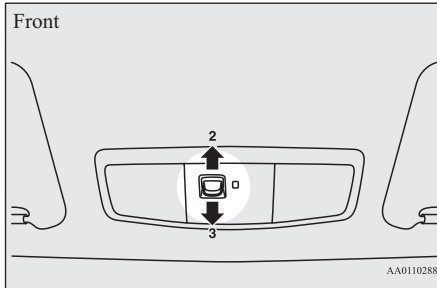

8

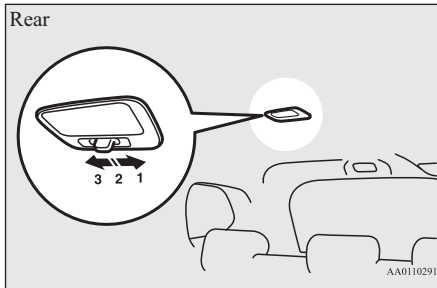

Position of lamp switch	On/off control
1-ON (☞)	The lamp illuminates regardless of whether a door or the tailgate is open or closed.

8-80 For pleasant driving

Position of lamp switch	On/off control
2-DOOR (◦)	<p>The lamp illuminates when a door or the tailgate is opened. It goes off approximately 15 seconds after all doors and the tailgate are closed. However, the lamp goes off immediately with all doors and the tailgate closed in the following cases:</p> <ul style="list-style-type: none"> ● When the operation mode is put in ON. ● When the central door lock function is used to lock the vehicle. ● When the keyless operation key is used to lock the vehicle. ● When the keyless operation function is used to lock the vehicle.
3-OFF (○)	The lamp goes off regardless of whether a door or the tailgate is open or closed.

OGGE19E1

NOTE

- When the operation mode is put in OFF while the doors and tailgate are closed, the lamp illuminates and after approximately 15 seconds it goes off.
- The time until the lamp goes off can be adjusted. For details, please consult a MITSUBISHI MOTORS Authorized Service Point. On vehicles equipped with the Smartphone Link Display Audio or the MITSUBISHI Multi-Communication System (MMCS), screen operations can be used to make the adjustment. Refer to the separate owner's manual for details.

Map lamps

E00712400168

Push the lens (A) to turn on the lamp. Push it again to turn it off.

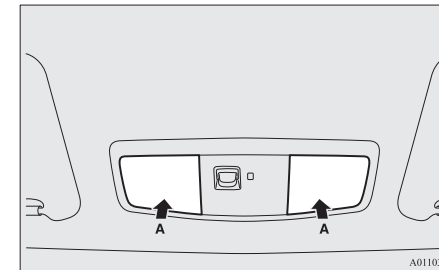

Luggage room lamp

E00712700709

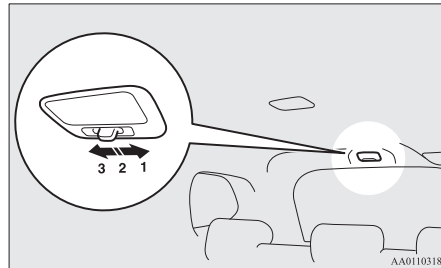

- 1- (☐)
The lamp illuminates regardless of whether the tailgate is open or closed.
- 2- (●)
The lamp illuminates when the tailgate is opened, and goes off when the tailgate is closed.
- 3- (○)
The lamp goes off regardless of whether the tailgate is open or closed.

Downlight

E00778700060

The downlight illuminates when the lamp switch is in the ☐ or ○ position. When the lamp switch is in the “AUTO” position (vehicles equipped with the automatic lamp control), the downlight illuminates when the position lamps and other lamps illuminate.

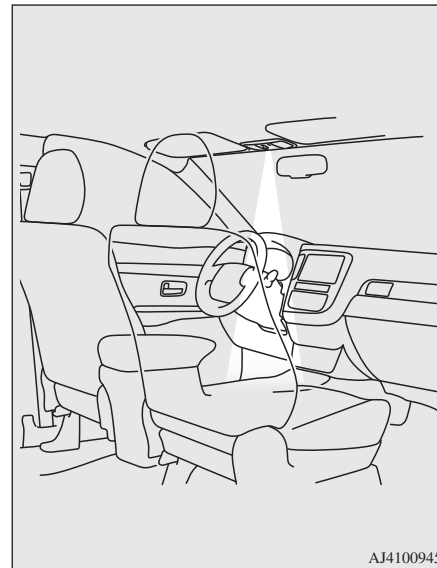

AJ4100945

Front foot lamps

E00776100073

The front foot lamps (A) come on when the front door is opened and go off when the door is closed.

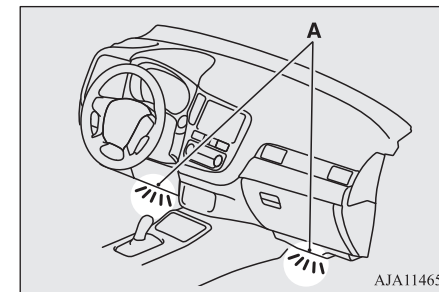

AJA114657

8

Interior lamp* auto-cutout function

E00712902587

*: Map & room lamps (front), room lamp (rear) and luggage room lamp

If any of the interior lamps are left switched on with the operation mode in OFF, it goes off automatically after approximately 30 minutes.

The lamps will illuminate again after they automatically go off if the power switch is operated, if one of the doors or the tailgate is opened or closed, or if the keyless entry system or keyless operation system is operated.

Storage spaces

NOTE

- The interior lamp auto-cut function can be deactivated. The time until the lamps automatically go off can be adjusted. For details and support, consult your nearest MITSUBISHI MOTORS Authorized Service Point.
On vehicles equipped with the Smartphone Link Display Audio or the MITSUBISHI Multi-Communication System (MMCS), screen operations can be used to make the adjustment. Refer to the separate owner's manual for details.

8

Storage spaces

E00713103394

CAUTION

- Never leave lighters, canned carbonated drinks, and spectacles in the cabin when parking the vehicle in hot sunshine. The cabin will become extremely hot, so lighters and other flammable items may catch fire and unopened drink cans may rupture. Also, spectacles with plastic lenses or materials could deform or crack.
- Keep the lids of storage spaces closed while driving the vehicle. A lid or the contents of a storage space could otherwise cause injuries.

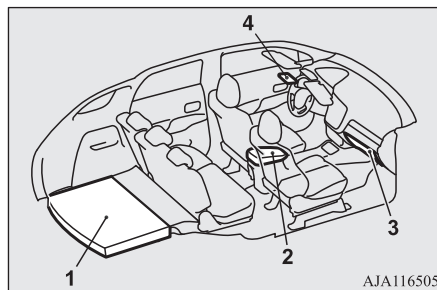

AJA116505

- 1- Luggage floor box
- 2- Floor console box
- 3- Glove box
- 4- Sunglasses holder*

Glove box

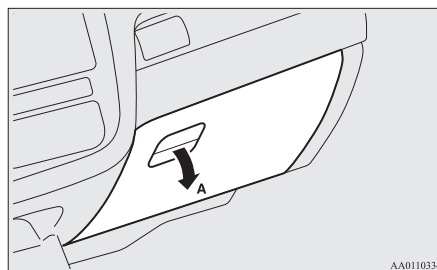

E00726201340

To open, pull the lever (A).



AA0110334

NOTE

- When the lamps are illuminated with the lamp switch in the “”, “”, or “AUTO” position, the glove box lamp illuminates.

Card holder

There is a card holder inside the glove box.

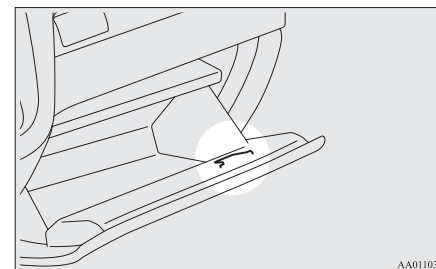

AA0110347

Floor console box

E00723302480

To open the console box, lift the release lever (A) and raise the lid.

The floor console box can also be used as an armrest.

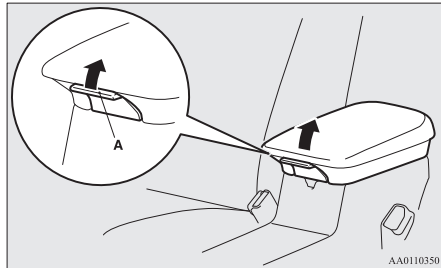

Luggage floor box

E00718701968

The box for storing articles is located inside the luggage compartment. To use the box, raise the luggage floor board (A).

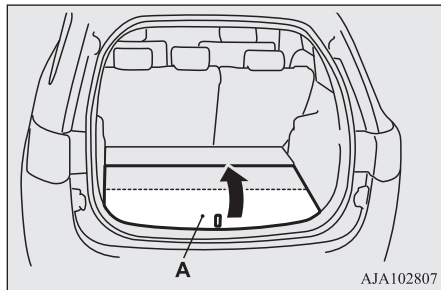

To use the luggage floor box in the rear seat side, insert your hand in the gap (B) and raise the board (A) to the seat side.

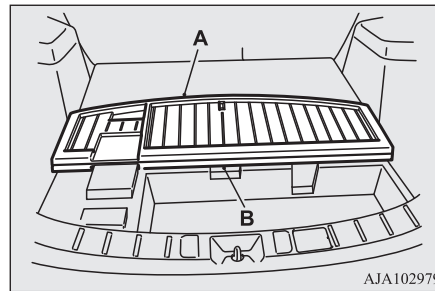

WARNING

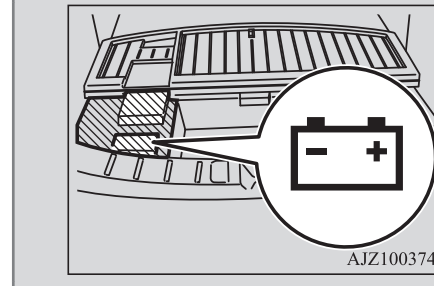

AJZ100374

Sunglasses holder*

E00718601417

To open, push the lid.

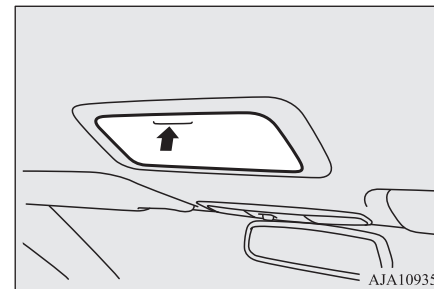

AJA109356

WARNING

- Do not place any object around the “” mark, since it marks the auxiliary battery under the luggage floor box. If the battery cover is broken, battery fluid may leak. If it adheres to your skin or gets in your eyes, serious injury may result.

Cup holder

⚠ CAUTION

- The holder should not be used to store anything heavier than sunglasses. These objects could drop out.

📖 NOTE

- The holder may not be able to accommodate every possible size and shape of sunglasses; it is advisable to check compatibility before use.

8

Cup holder

E00714502343

⚠ WARNING

- Do not spray water or spill beverages inside the vehicle. If the switches, wires or electrical components become wet, they could malfunction or cause a vehicle fire. If you accidentally spill a beverage, wipe up as much liquid as possible and immediately consult a MITSUBISHI MOTORS Authorized Service Point.

⚠ CAUTION

- Do not drink beverages while driving. This is distracting and could cause an accident.

For the front seat

The cup holder is located in front of the floor console.

To use the cup holder, push the lid.

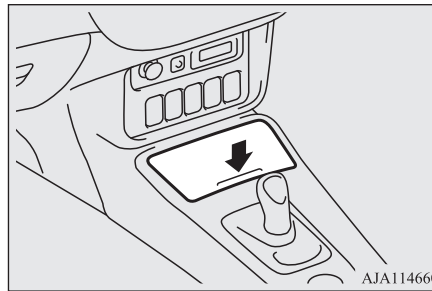

For the rear seat

E00716901562

In order to use the cup holder, allow the armrest to drop down.

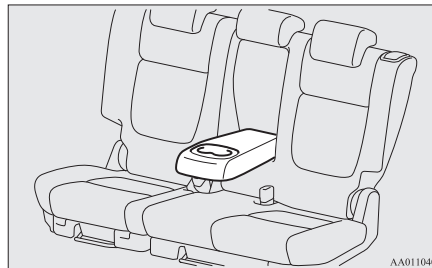

Bottle holder

E00718201543

⚠ WARNING

- Do not spray water or spill beverages inside the vehicle. If the switches, wires or electrical components become wet, they could malfunction or cause a vehicle fire. If you accidentally spill a beverage, wipe up as much liquid as possible and immediately consult a MITSUBISHI MOTORS Authorized Service Point.

⚠ CAUTION

- Do not drink beverages while driving. This is distracting and could cause an accident.
- Drinks could be spilled by the vibration and jolts while driving. If the spilt drink is very hot, you could be burnt.

There are bottle holders located on both sides of front and rear doors.

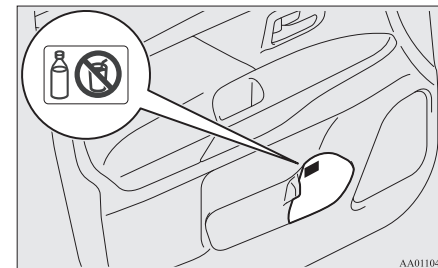

Cargo area cover

NOTE

- Do not store cups or drink cans in the bottle holder.
- Tightly close the cap on drink bottles before storing them.
- Some bottles may be too big or the wrong shape to fit in the holder.

Cargo area cover

E00733601160

To use

1. Draw out the cover retracted by spring and insert it in the mounting grooves (A).

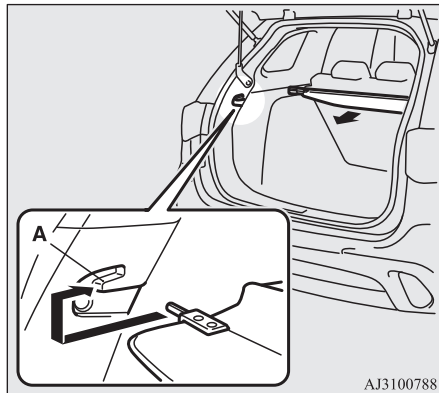

2. Remove the cover from the mounting grooves, and the cover will roll back into the retracted position.

NOTE

- Do not put luggage on the cover.

To change position

There are two installation holes (B) for the cover.

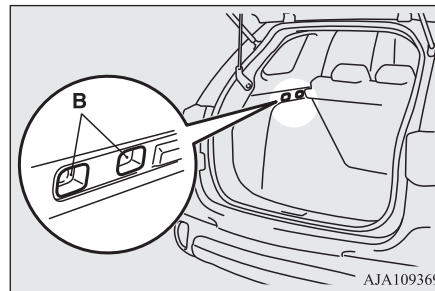

1. Move one of the sliders (C) towards the inside of the vehicle, and fit the tab (D) into the installation hole that is to be used. Move the opposite slider in the same fashion.

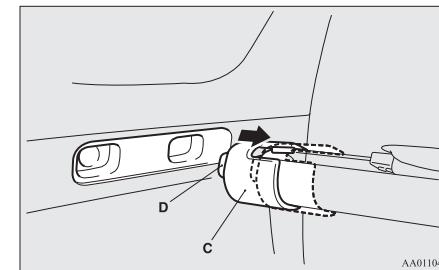

8

2. After changing the position, gently shake the entire cover to make sure it is securely retained.

NOTE

- If the rear seatback touches the cover, move the cover rearward. The cover could break if it supports the seatback of the rear seat.

To remove

1. Roll the cover into the retracted position.

Assist grips

2. Move one of the sliders (C) towards the inside of the vehicle and lift it to remove the cover.

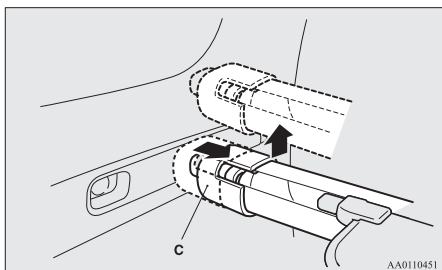

8

To refit

Refit the cover by performing the removal steps in reverse.

Gently shake the entire cover after fitting it to make sure it is securely retained.

Assist grips

E00732800298

The assist grips (located above the doors on the headliner) are not designed to support body weight. They are intended for use only while seated in the vehicle.

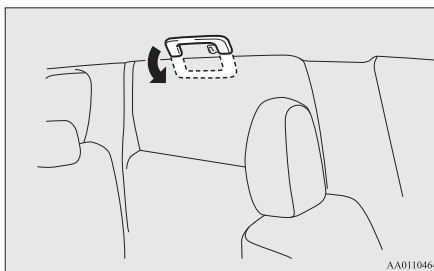

CAUTION

- Do not use the assist grips when getting into or out of the vehicle. The assist grips could detach causing you to fall.

Coat hook

E00725601640

There is a coat hook on the rear seat assist grip of the driver's side.

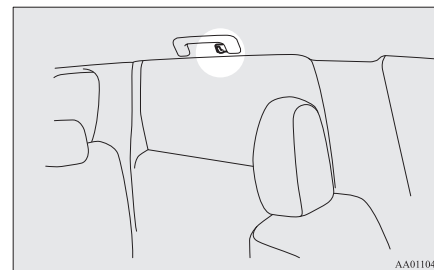

WARNING

- Do not put a hanger or any heavy or pointed object on the coat hook. If the curtain airbag was activated, any such item could be propelled away with great force and could prevent the curtain airbag from inflating correctly. Hang clothes directly on the coat hook (without using a hanger). Make sure there are no heavy or sharp objects in the pockets of clothes that you hang on the coat hook.

Luggage hooks

E00715700579

There are 4 hooks located on the side walls of the luggage compartment. Use the hooks for securing the luggage.

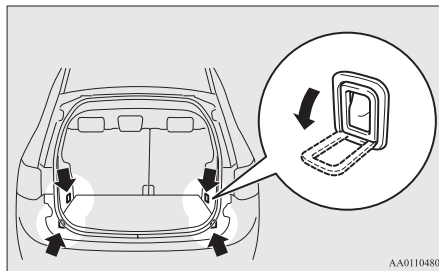

CAUTION

- Do not pile up the luggage beyond the seat-back height. Also, firmly secure the luggage. Otherwise, serious accidents could result due to hindered rearward view or flying objects during sudden braking.

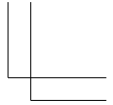
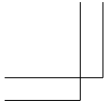

Handwriting practice lines consisting of 12 horizontal dashed lines.

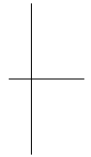
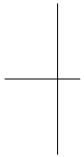

OGGE19E1

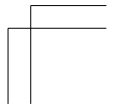
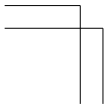

For emergencies

If the vehicle breaks down.....	9-02
If the operation mode cannot be changed to OFF.....	9-02
Emergency starting.....	9-02
Engine overheating.....	9-04
Tools and jack.....	9-06
Tyre repair kit.....	9-07
How to change a tyre.....	9-13
Towing.....	9-17
Operation under adverse driving conditions.....	9-21

If the vehicle breaks down

If the vehicle breaks down

E00800102408

If the vehicle breaks down on the road, move it to the shoulder and use the hazard warning flashers and/or the warning triangle etc. Refer to “Hazard warning flasher switch” on page 6-67.

If you need to push your vehicle, put the operation mode of the power switch in ON and put the select position in “N” (NEUTRAL) position.

WARNING

- If you are unable to safely assess the vehicle due to vehicle damage, do not touch the vehicle. Leave the vehicle and contact emergency services. Advise emergency responders that this is a Plug-in Hybrid Electric vehicle.

If the ready indicator goes out while driving

Vehicle operation and control are affected if the ready indicator goes out while driving. Before moving the vehicle to a safe area, be aware of the following:

- The brake booster may become inoperative and the pedal effort will increase. Press down the brake pedal harder than usual.

9-02 For emergencies

- The power steering system may not operate, the steering wheel feels heavy when turning it.

If the operation mode cannot be changed to OFF

E00804900295

If the operation mode cannot be changed to OFF, perform the following procedure.

1. Press the electrical parking switch and lock the wheels, then change the operation mode to OFF.
2. One of the other causes could be low auxiliary battery voltage. If this occurs, the keyless entry system and keyless operation function will also not operate. Contact a MITSUBISHI MOTORS Authorized Service Point.

Emergency starting

E00800504204

If the Plug-in Hybrid EV system cannot be started because the auxiliary battery is weak or dead, the battery from another vehicle can be used with jumper cables to start the Plug-in Hybrid EV system.

WARNING

- To start the Plug-in Hybrid EV system using jumper cables from another vehicle and perform the correct procedures according to the instruction below. Incorrect procedures could result in a fire, explosion, electric shock or damage to the vehicles.
- Keep sparks, cigarettes and flames away from the battery because the battery may produce an explosion.

CAUTION

- The Plug-in Hybrid EV system cannot be started by pulling or pushing the vehicle.
- Check the other vehicle. It must have a 12-volt battery. If the other system isn't 12-volt, shorting can damage both vehicles.
- Use the proper cables suitable for the battery size to prevent overheating of the cables.
- Check the jumper cables for damage and corrosion before use.
- Always wear protective eye goggles when working near the battery.
- Keep the battery out of the reach of children.
- Do not attempt jump starting the auxiliary battery while the drive battery is being charged. Doing so could damage the charging equipment or the vehicle.

OGGE19E1

NOTE

- If the auxiliary battery is disconnected, the operation mode of the power switch is memorized. When a booster battery is connected by jumper cables, the operation mode returns to the state it had before the auxiliary battery ran down.
Pay due attention if you do not know the operation mode before the auxiliary battery was fully discharged.
- If the auxiliary battery is fully discharged with the select position in the “P” (PARK) position, the select position cannot be changed to other position from the “P” (PARK) position in some cases. In such a case, the front wheels have been locked. Therefore, the vehicle cannot be moved.

1. Get the vehicles close enough so the jumper cables can reach, but be sure the vehicles aren't touching each other.
2. Turn off all lamps, heater and other electrical loads.
3. Set the parking brake firmly on each vehicle. Set the gear of the other vehicle in “P” (PARK) position (with A/T) or in “N” (Neutral) position (with M/T) and stop the engine.

WARNING

- **When connecting the jumper cable, stop the engine in the other vehicle. Otherwise, the cables or your clothes may be caught by the fan or drive belt and personal injury could result.**
- **The cooling fan turns on and off depending on the coolant temperature. Do not bring your hands close to the fan while the engine is running or the Plug-in Hybrid EV System is operating.**

4. Open the bonnet, remove the fuse cover of the main fuse block.
Refer to “Bonnet” on page 11-04 and “Fuses: Engine compartment” on page 11-18.
5. Open the cover of the jumper cable terminal in the main fuse block.

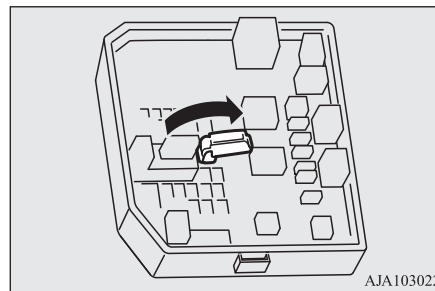

NOTE

- You cannot rescue another vehicle's discharged battery by connecting jumper cables while using this jumper cable terminal.

6. Connect one end of one jumper cable ① to the jumper cable terminal (A) of your vehicle, and the other end ② to the positive (+) terminal of the booster battery (B).
Connect one end of the other jumper cable ③ to the negative (-) terminal of the booster battery, and the other end ④ to

Engine overheating

the designated ground location of your vehicle.

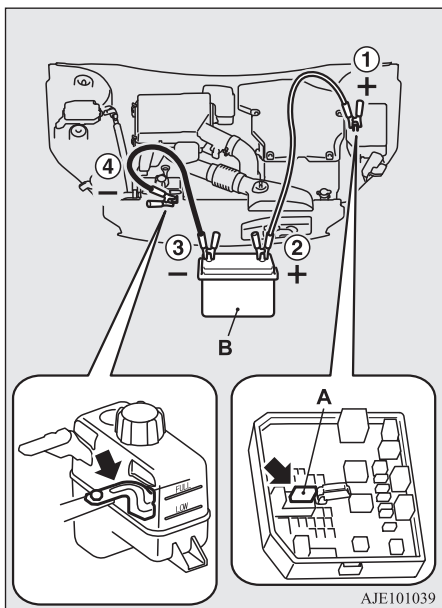

9

WARNING

- When connecting the jumper cables, do not connect the positive (+) cable to the negative (-) terminal. Otherwise sparks might cause explosion of the battery.

CAUTION

- Take care not to get the jumper cable caught in the cooling fan or other rotating part in the engine compartment.

NOTE

- If the jumper cable is connected to any position other than the appointed one, it may cause damage to the vehicle.

7. Start the engine in the vehicle which has the booster battery, let the engine idle a few minutes, then start the Plug-in Hybrid EV system in your vehicle.
8. Check if the ready indicator illuminates. If the ready indicator does not illuminate, contact a MITSUBISHI MOTORS Authorized Service Point.
9. When the ready indicator illuminates, disconnect the jumper cables in the reverse order of connection.
10. Check if the select position can be shifted to all positions other than the "P" (PARK) position.
11. Have the auxiliary battery inspected by your nearest MITSUBISHI MOTORS Authorized Service Point.

CAUTION

- Your vehicle is equipped with an exclusive auxiliary battery. Even if the battery type is the same, the battery may not be correctly installed in your vehicle. When replacing the auxiliary battery, request a MITSUBISHI MOTORS Authorized Service Point to do so.

Engine overheating

E00800604221

When the engine is overheating, the warning display will appear on the information screen in the multi information display.

Warning display



If this occurs, take the following corrective measures:

1. Stop the vehicle in a safe place.
2. Check whether steam is coming from the engine compartment.

[If steam does not come from the engine compartment]

Engine overheating

With the Plug-in Hybrid EV system still starting, raise the bonnet to ventilate the engine compartment.

[If steam is coming from the engine compartment]
Stop the Plug-in Hybrid EV system, and when the steam stops, raise the bonnet to ventilate the engine compartment. Restart the Plug-in Hybrid EV system.

WARNING

- Do not open the bonnet while steam is coming from the engine compartment. It could cause steam or hot water to spurt out, causing burns. Hot water could spurt out even when there is no steam coming out, and some parts will be very hot. Be very careful when opening the bonnet.
- Be careful of hot steam, which could be blowing off the reserve tank cap.
- Do not attempt to remove the radiator cap while the engine is hot.

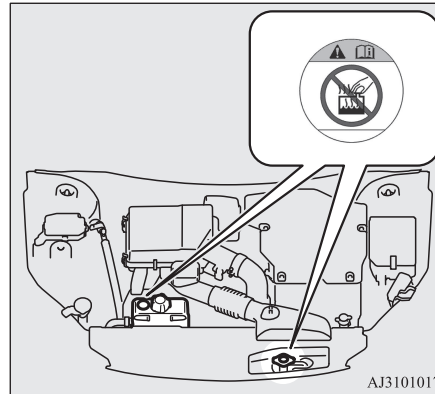

3. Confirm that the cooling fans (A) are turning.

[If the cooling fans are turning]
After the high coolant temperature warning has gone off, stop the Plug-in Hybrid EV system.

[If the cooling fans are not turning]
Stop the Plug-in Hybrid EV system immediately and contact a MITSUBISHI

MOTORS Authorized Service Point for assistance.

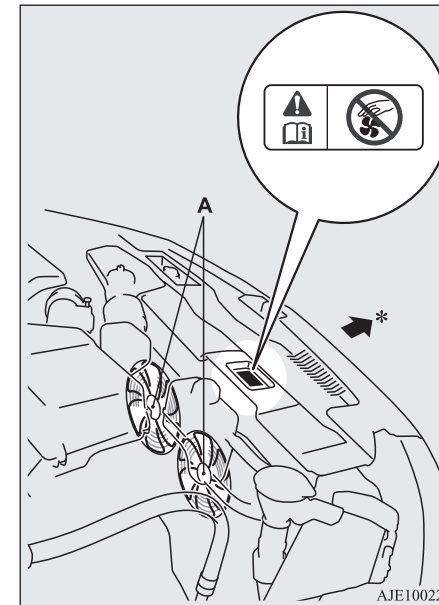

*: Front of the vehicle

WARNING

- Be careful not to get your hands or clothes caught in the cooling fan.

Tools and jack

4. Check the coolant level in the reserve tank (B and C).

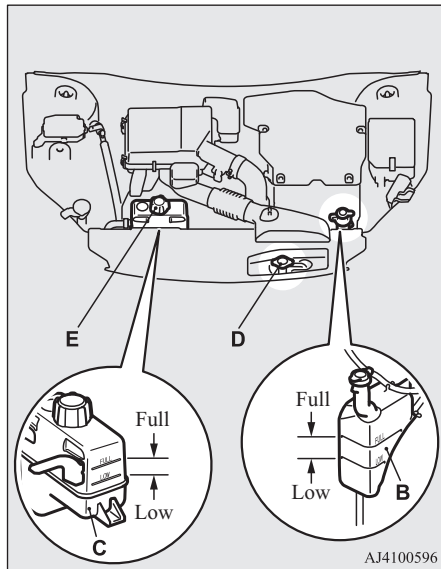

B: Reserve tank for engine cooling
C: Reserve tank for EV cooling system

5. Add coolant to the radiator and/or reserve tank if necessary. (Refer to the “Maintenance” section.)

⚠ WARNING

- Make sure that the engine and the Plug-in Hybrid EV system have cooled down before removing the radiator cap (D) and the reserve tank cap (E), because hot steam or boiling water will otherwise gush from the filler port and may scald you.

⚠ CAUTION

- Do not add coolant while the engine is hot. Suddenly adding cold coolant could damage the engine. Wait for the engine to cool down, then add coolant a little at a time.

6. Examine the radiator hoses for coolant leakage and the drive belt for looseness or damage.
If there is anything wrong with the cooling system or drive belt, we recommend you to have it checked and repaired.

Tools and jack

E00800902507

Storage

The tools are stowed on the right side of the luggage area.
The jack is stowed in the luggage floor box.

The storage location of the tools and jack should be remembered in case of an emergency.

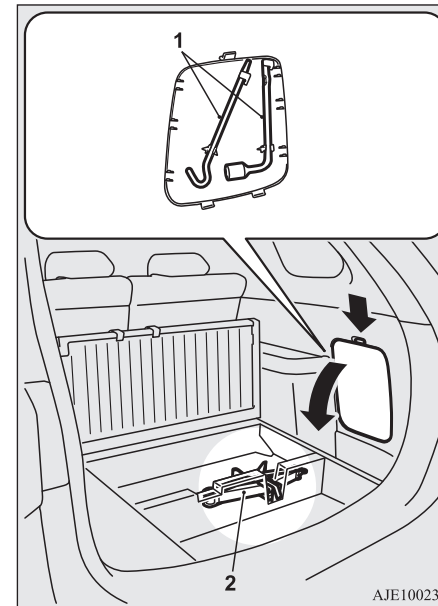

- 1- Tools
2- Jack

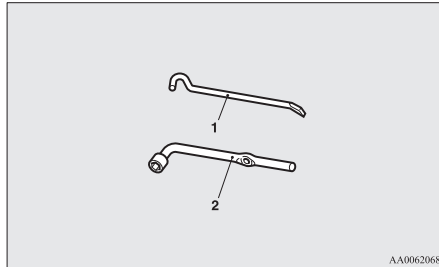
Tools

- 1- Jack bar
2- Wheel nut wrench

Jack

The jack is used only for the purpose of changing a tyre when a tyre is punctured.

NOTE

- The jack is maintenance-free.
- The jack is in conformity with EC law as approximated by the Machinery Directive 2006/42/EC.
- The EC declaration of conformity is attached to the section "Declaration of Conformity" in the end of this owner's manual.

NOTE

- The business name, full address of the manufacturer and of his authorized representative and the designation of the jack are described in the EC declaration of conformity.

To remove

1. Raise the luggage floor board.
Refer to "Luggage floor box" on page 8-83.
2. Remove the band (A) and take out the jack.

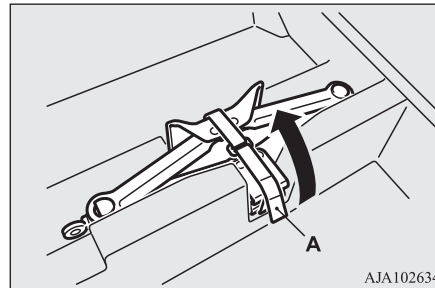
**To store**

Perform the removal steps in reverse.

Tyre repair kit

E00804501142

This kit enables emergency repair of a small puncture in the tread area of a tyre that has run over a nail, screw, or similar object.

Storage

The tyre repair kit is stored beneath the luggage floor board of the luggage compartment.

Tyre repair kit

The storage location of the tyre repair kit should be remembered in case of an emergency.

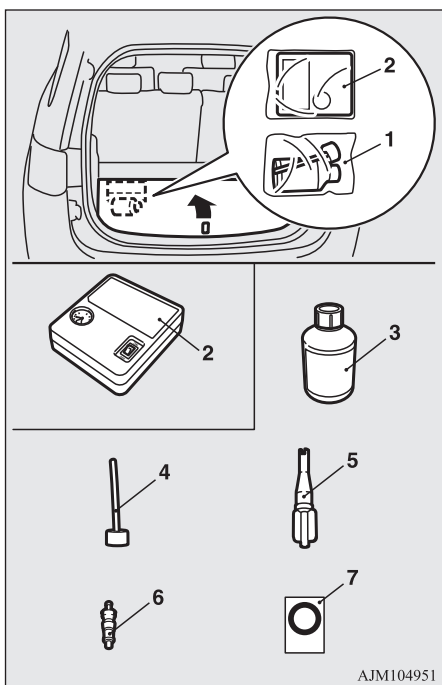

- 1- Tyre repair set
- 2- Tyre compressor
- 3- Tyre sealant bottle
- 4- Filler hose

9-08 For emergencies

- 5- Valve remover
- 6- Valve insert (spare)
- 7- Speed restriction sticker

How to use the tyre repair kit

E00804601130

WARNING

- Using the tyre repair kit may damage the wheel and/or the tyre inflation pressure sensor for the tyre. The vehicle must promptly be inspected and repaired by a MITSUBISHI MOTORS Authorized Service Point after using the tyre repair kit.

CAUTION

- The tyre sealant can cause health damage if swallowed. If you accidentally swallow it, drink as much water as possible and immediately consult a doctor.
- If the tyre sealant gets in your eyes or on your skin, rinse with lots of water. If you still sense an abnormality, consult a doctor.
- Consult a doctor immediately if any allergic reactions occur.
- Do not allow children to touch the tyre sealant.
- Do not breathe in the vapours of tyre sealant.
- Be sure to use a MITSUBISHI MOTORS GENUINE tyre sealant.

NOTE

- The tyre sealant cannot be used in any of the situations listed below. If any of these situations occurs, please contact a MITSUBISHI MOTORS Authorized Service Point or another specialist.
 - The tyre sealant's expiry date has passed. (The expiry date is shown on the bottle label.)



- More than one tyre is punctured.
- The puncture hole has a length or width of 4 mm or more.
- The tyre is punctured in the side wall (A), not in the tread (B).

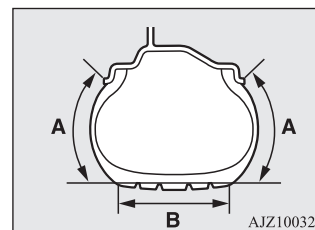

OGGE19E1

NOTE

- The vehicle has been driven with the tyre almost completely flat.
- The tyre has completely slipped over the wheel rim and has come off the wheel.
- The wheel is damaged.
- Use the tyre sealant only at ambient temperatures of -30 °C to + 60 °C.
- Effect an emergency repair without pulling out the object (nail, screw, etc.) that is stuck in the tyre.
- Do not use the tyre sealant if the tyre has been damaged by being driven when insufficiently inflated (e.g. bumps, cuts, cracks etc. on the tyre).
- Wipe tyre sealant off the paintwork immediately with a damp cloth.
- Immediately wash clothes contaminated with tyre sealant.
- Check the tyre sealant's expiry date regularly, and be sure to purchase a new one from a MITSUBISHI MOTORS Authorized Service Point before the expiry date.

Before repairing a tyre, first stop your vehicle in a safe, flat location.

1. Park the vehicle on level and stable ground.
2. Set the parking brake firmly.
3. Put the select position in "P" (PARK) position and stop the Plug-in Hybrid EV system.

4. Turn on the hazard warning flashers and set up a warning triangle, flashing signal lamp, etc., at an adequate distance from the vehicle, and have all your passengers leave the vehicle.
5. Take out the tyre repair kit.
6. Take the valve cap (C) off the tyre valve (D), then press the valve remover (E) onto the valve as illustrated. Allow all of the air in the tyre to escape.

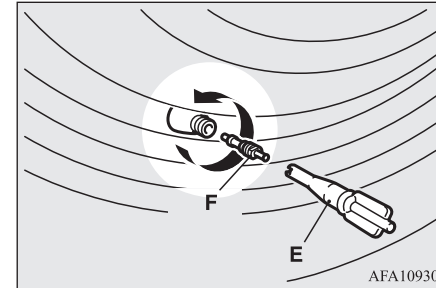
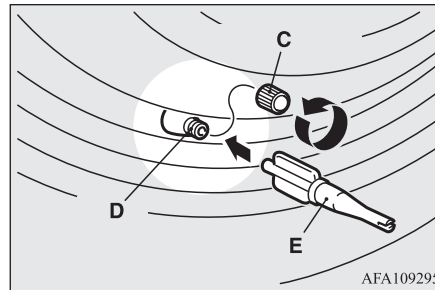
**CAUTION**

- If there is any air left in the tyre when you remove the valve insert, the valve insert may fly out and injure you. Make sure the tyre contains no air before removing the valve insert.

8. Shake the tyre sealant bottle well.

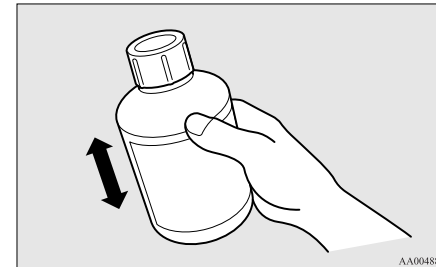

Tyre repair kit

NOTE

- In cold conditions (when the ambient temperature is 0 °C or lower), thickening of the tyre sealant can make the tyre sealant hard to squeeze out of the bottle. Warm the bottle inside the vehicle.

9. Take the cap (G) off the tyre sealant bottle (H). Do not remove the seal (I). Screw the filler hose (J) onto the bottle (H). As you screw the filler hose onto the bottle, the seal will break, allowing the sealant to be used.

9

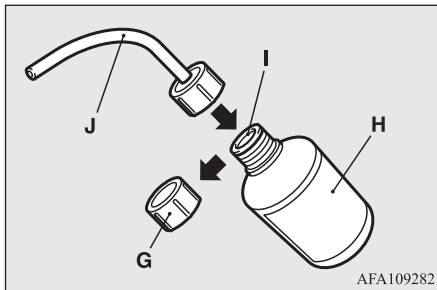

CAUTION

- If you shake the bottle after screwing on the hose, sealant may spray out of the hose.

10. Press the hose onto the valve (D). Holding the sealant bottle upside-down,

9-10 For emergencies

squeeze it again and again to inject all of the sealant into the tyre.

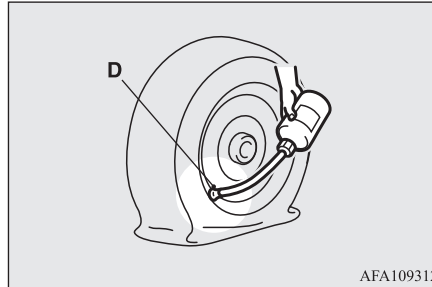

NOTE

- When injecting the sealant, position the valve away from the bottom, i.e., away from the point where the tyre touches the ground. If the valve is near the point where the tyre touches the ground, the sealant may not go into the tyre easily.

11. After injecting the sealant, pull the hose off the valve, remove any residual sealant from the valve, rim and/or tyre. Fit the valve insert (F) into the valve (D), and screw the valve insert securely into place using the valve remover (E).

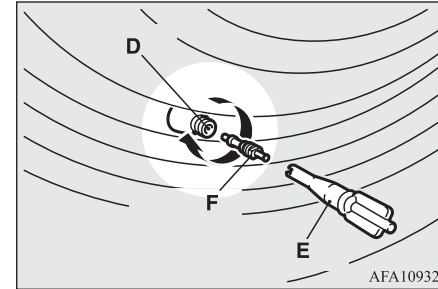

NOTE

- When removing and screwing in the valve insert using the valve remover, turn the valve remover by hand. Using a tool to turn the valve remover could damage it.

12. After injecting the sealant, securely fit the valve remover (E) into the end of the filler hose (J) to prevent sealant from leaking from the empty bottle.

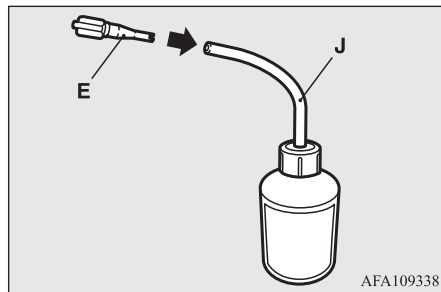

13. Pull out the compressor hose (K) from the side of the tyre compressor, and then securely attach the hose to the tyre valve (D).

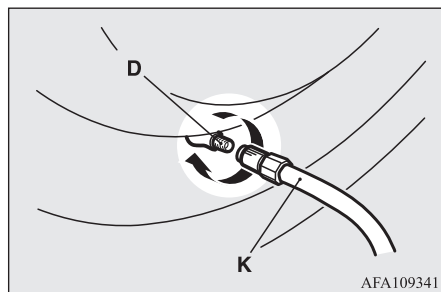

14. Place the compressor (L) with its air pressure gauge (M) on top.

Pull out the compressor's power cord (N), insert the plug on the cord into the accessory socket (O), and then put the operation mode of the power switch in ACC. (Refer to "Accessory socket*" on page 8-75.)

Turn ON the compressor switch (P) and inflate the tyre to the specified pressure. (Refer to "Tyre inflation pressures" on page 11-10.)

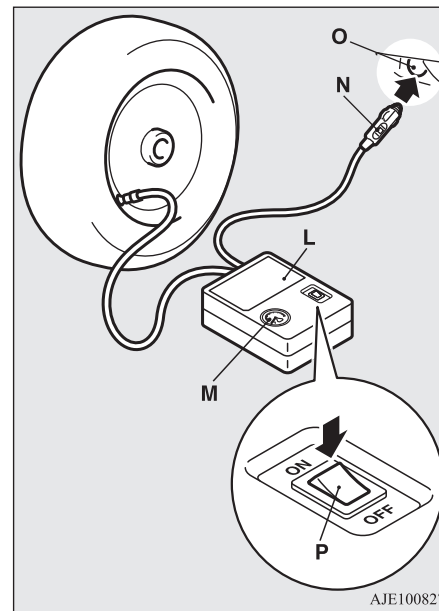

CAUTION

- The supplied compressor is designed only for inflation of your vehicle tyres.
- The compressor is designed to run on a vehicle's 12 V power supply. Do not connect it to any other power source.
- The compressor is not waterproof. If you use it in rain, make sure water does not get on it.
- Any sand or dust sucked into the compressor could make the compressor break down. Do not place the compressor directly on any sandy or dusty surface when using it.
- Do not disassemble or modify the compressor. Also, do not subject the air pressure gauge to shock. It could malfunction.

15. Check and adjust the tyre pressure with reference to the air pressure gauge on the compressor. If you overinflate the tyre, release air by loosening the hose's end fitting.

If there is a gap between the tyre and wheel because the tyre has moved inward from the wheel rim, press the periphery of the tyre towards the wheel to close the gap before running the compressor. (With no gaps, the tyre pressure will rise.)

CAUTION

- Be careful not to get your fingers trapped between the tyre and wheel as the tyre inflates.

Tyre repair kit

CAUTION

- The surface of the compressor will get hot while the compressor is running. Do not keep the compressor running continuously for more than 10 minutes. After using the compressor, wait for the compressor to cool before using it again.
- If the compressor becomes sluggish or hot while operating, it is overheating. Immediately place the switch in the OFF position and let the compressor cool down for at least 30 minutes.

NOTE

- If the tyre pressure does not rise to the specified level within 10 minutes, the tyre may be so severely damaged that the tyre sealant cannot be used to effect an emergency repair. Please contact a MITSUBISHI MOTORS Authorized Service Point or another specialist in this event.

16. Turn OFF the compressor switch, then pull the power cord plug out of the socket.

NOTE

- Simply putting sealant and air into the tyre using the tyre repair kit does not seal the puncture hole. Air will leak through the puncture hole until the emergency repair procedure is completed (through step 19 or step 20 of these instructions).

17. Affix the speed restriction sticker (Q) to the three-diamond mark on the steering wheel.

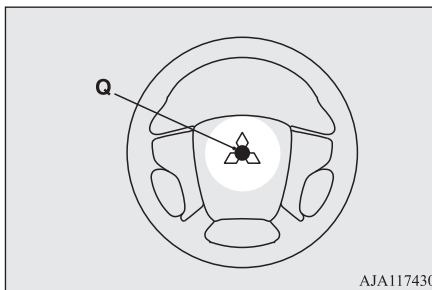

CAUTION

- Do not affix the sticker anywhere except the specified position on the pad of the steering wheel. Affixing the sticker in an incorrect position could prevent the SRS airbag from working normally.

18. When you have inflated the tyre to the specified pressure, stow the compressor,

bottle, and other items in the vehicle and promptly start driving the vehicle so that the tyre sealant can spread evenly in the tyre. Drive with great care. Do not exceed a speed of 80 km/h (50 mph). Observe local speed limits.

CAUTION

- If you sense any abnormality while driving, stop the vehicle and contact a MITSUBISHI MOTORS Authorized Service Point or another specialist. Otherwise the tyre pressure may drop before the emergency repair procedure is completed, rendering the vehicle unsafe.

NOTE

- Driving faster than 80 km/h (50 mph) can make the vehicle vibrate.

19. After driving for 10 minutes or 5 km, check the tyre pressure using the air pressure gauge on the compressor. If the tyre pressure has apparently not dropped, the emergency repair procedure is complete. Continue the process from step 21.

If the tyre pressure is not sufficient, inflate the tyre to the specified pressure again and drive the vehicle carefully without exceeding a speed of 80 km/h.

⚠ CAUTION

- If the tyre pressure is lower than the minimum permitted pressure (1.3 bar {130 kPa}), the tyre cannot successfully be repaired with the tyre sealant. Do not drive the vehicle any further. Contact a MITSUBISHI MOTORS Authorized Service Point or another specialist.

20. After driving for 10 minutes or 5 km, check the tyre pressure using the air pressure gauge on the compressor. If the tyre pressure has apparently not dropped, the emergency repair procedure is complete. You must still not exceed a speed of 80 km/h. Observe local speed limits.

📖 NOTE

- If the tyre pressure has dropped below the specified level when you check it at the end of the repair procedure, do not drive the vehicle any further. Contact a MITSUBISHI MOTORS Authorized Service Point or another specialist.

📖 NOTE

- In cold conditions (when the ambient temperature is 0 °C or lower), the time and driving distance necessary until completion of the repair can be longer than in warmer conditions, meaning that the tyre pressure can drop below the specified level even when you have inflated the tyre a second time and subsequently driven the vehicle. If this happens, inflate the tyre to the specified pressure once more, drive for about 10 minutes or 5 km, then check the tyre pressure again. If the tyre pressure has again dropped below the specified level, stop driving the vehicle and contact a MITSUBISHI MOTORS Authorized Service Point or another specialist.

21. Immediately drive with great care to a MITSUBISHI MOTORS Authorized Service Point and have tyre repair/replacement performed.

⚠ CAUTION

- Be sure to check the tyre pressure for confirmation that the emergency repair procedure is complete.

📖 NOTE

- Please give the empty sealant bottle to your MITSUBISHI MOTORS Authorized Service Point when you purchase new sealant or dispose of the sealant bottle according to national regulations for the disposal of chemical waste.
- A tyre in which puncture sealant has been used should ideally be replaced with a new one. If you wish to have such a tyre properly repaired for reuse, please contact a MITSUBISHI MOTORS Authorized Service Point or another specialist. Note that a proper repair is impossible following an emergency repair if the puncture hole cannot be located.
- The manufacturer is unable to guarantee that all tyre punctures can be repaired with the tyre repair kit, in particular cuts or perforations with a diameter of more than 4 mm or away from the tyre's tread. The manufacturer is not liable for damage sustained through improper use of the tyre repair kit.
- The manufacturer is not liable for damage sustained through re-use of any tyre in which tyre sealant has been used.

How to change a tyre

E00801203924

Before changing a tyre, first stop your vehicle in a safe, flat location.

1. Park the vehicle on level and stable ground, free of loose pebbles, etc.
2. Set the parking brake firmly.

For emergencies 9-13

How to change a tyre

- Put the select position in “P” (PARK) position and stop the Plug-in Hybrid EV system.
- Have all your passengers get out of the vehicle.
- To prevent the vehicle from rolling when jacking up the vehicle, place chocks or blocks (A) at the tyre that is diagonally opposite from the tyre (B) you are changing.

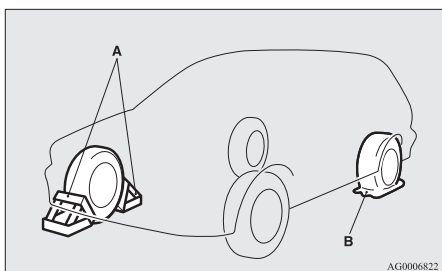

⚠ WARNING

- Be sure to apply chocks or blocks to the correct tyre when jacking up the vehicle. If the vehicle moves while jacked up, the jack could slip out of position, leading to an accident.

📖 NOTE

- The chocks shown in the illustration do not come with your vehicle. It is recommended that you keep one in the vehicle for use if needed.
- If chocks are not available, use stones or any other objects that are large enough to hold the wheel in position.

- Get the jack, jack bar and wheel nut wrench ready. Refer to “Tools and jack” on page 9-06.

To change a tyre

E00803202745

- Loosen the wheel nuts a quarter turn with the wheel nut wrench. Do not remove the wheel nuts yet.

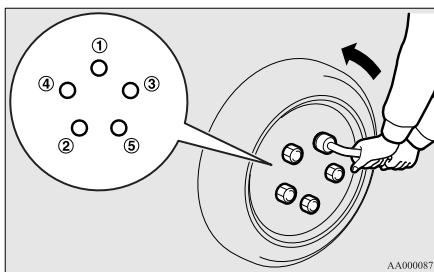

- Place the jack under one of the jacking points (A) shown in the illustration. Use

the jacking point closest to the tyre you wish to change.

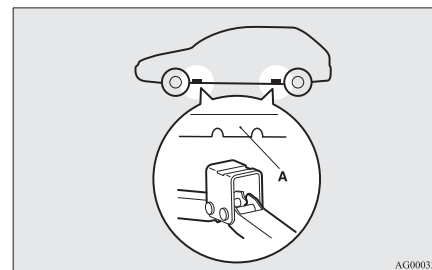

⚠ WARNING

- Set the jack only at the positions shown here. If the jack is set at a wrong position, it could dent your vehicle or the jack might fall over and cause personal injury.
- Do not use the jack on a tilted or soft surface. Otherwise, the jack might slip and cause personal injury. Always use the jack on a flat, hard surface. Before setting the jack, make sure there are no sand or pebbles under the jack base.

How to change a tyre

3. Rotate the jack by hand until the flange portion (B) fits in the groove (C) at the top of the jack.

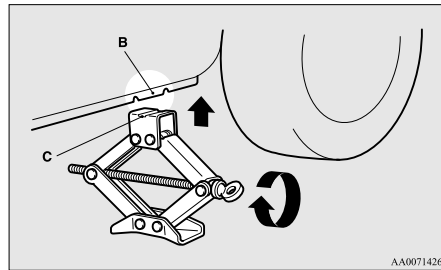

- Slowly rotate the wheel nut wrench until the tyre is raised slightly off the ground surface.

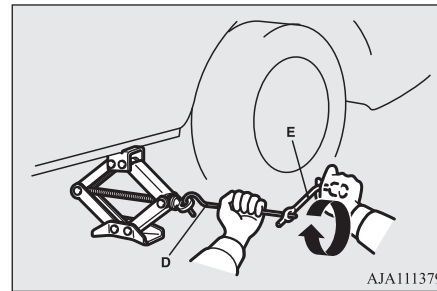

⚠ WARNING

- Do not turn the raised wheel. The tyres still on the ground could turn and make your vehicle fall off the jack.

5. Remove the wheel nuts with the wheel nut wrench, then take the wheel off.

⚠ CAUTION

- Handle the wheel carefully when changing the tyre, to avoid scratching the wheel surface.

4. Check that the flange portion at the jacking point fits in the groove at the top of the jack.

Insert the jack bar (D) into the wheel nut wrench (E). Then put the end of the jack bar into the shaft's jack end, as shown in the illustration.

⚠ WARNING

- Stop jacking up the vehicle as soon as the tyre is raised off the ground. It is dangerous to raise the vehicle any higher.
- Do not get under your vehicle while using the jack.
- Do not bump the raised vehicle or leave it sitting on the jack for a long time. Both are very dangerous.
- Do not use a jack except the one that came with your vehicle.
- The jack should not be used for any purpose other than to change a tyre.
- No one should be in your vehicle when using the jack.
- Do not start the Plug-in Hybrid EV system while your vehicle is on the jack.

6. Clean out any mud, etc. on the hub surface (F), hub bolts (G) or in the installation holes (H) in the wheel, and then mount the tyre.

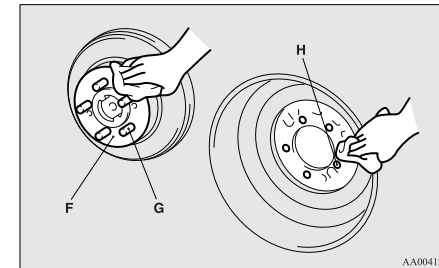

9

How to change a tyre

⚠ WARNING

- Mount the wheel with the valve stem (I) facing outboard. If you cannot see the valve stem (I), you have installed the wheel backwards. Operating the vehicle with the wheel installed backwards can cause vehicle damage and result in an accident.

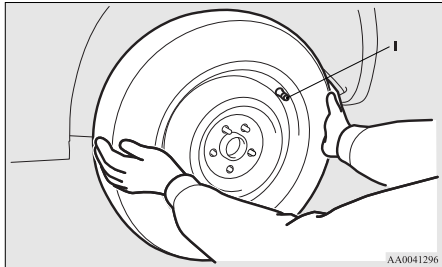

9

7. Turn the wheel nuts clockwise by hand to initially tighten them. Temporarily tighten the wheel nuts by hand until the flange parts of the wheel

nuts make light contact with the wheel and the wheel is not loose.

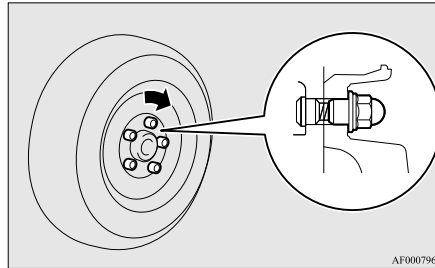

⚠ CAUTION

- Never apply oil to either the wheel bolts or the nuts, or they will tighten too much.

8. Lower the vehicle slowly by rotating the wheel nut wrench anticlockwise until the tyre touches the ground.

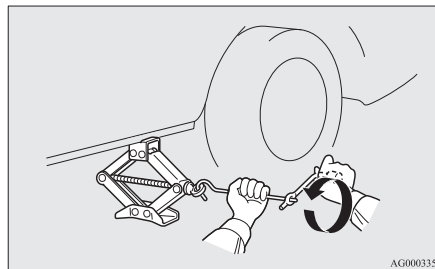

9. Tighten the nuts in the order shown in the illustration until each nut has been tightened to the torque listed here.

Tightening torque: 88 to 108 N•m

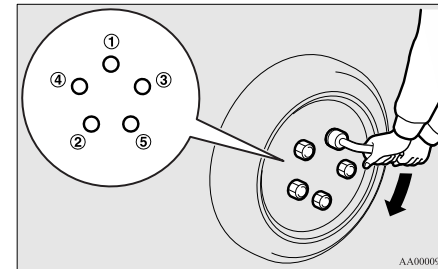

⚠ CAUTION

- Never use your foot or a pipe extension for extra force in the wheel nut wrench. If you do so, you will tighten the nut too much.

10. Lower and remove the jack, then store the jack, flat tyre, and chocks. Have your damaged tyre repaired as soon as possible.
11. Check your tyre inflation pressure at the next gasstation. The correct tyre pres-

ures are shown on the driver's door label. See the illustration.

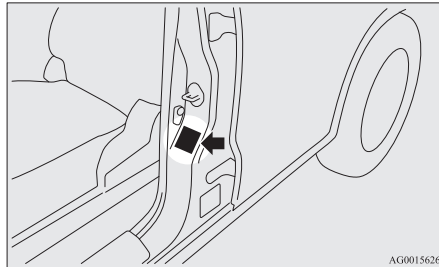

12. After filling your tyres to the correct pressure, reset the tyre pressure monitoring system (TPMS). Refer to "Tyre pressure monitoring system (TPMS): Reset of low tyre pressure warning threshold" on page 7-96.

CAUTION

- After changing the tyre and driving the vehicle about 1,000 km (620 miles), retighten the wheel nuts to make sure that they have not come loose.
- If the steering wheel vibrates when driving after changing the tyre, we recommend you to have the tyres checked for balance.
- Do not mix one type of tyre with another or use a different size from the one listed. This would cause early wear and poor handling.

To store the tools and jack

E0080380037

Reverse the removing procedure when storing the jack, jack bar and wheel nut wrench. Refer to "Tools and jack" on page 9-06.

Towing

E00801504953

If your vehicle needs to be towed

If you need to tow your vehicle, we recommend that you contact a MITSUBISHI MOTORS Authorized Service Point or a commercial tow truck service.

Transport the vehicle on a flatbed truck or tow the vehicle with all wheels off the ground.

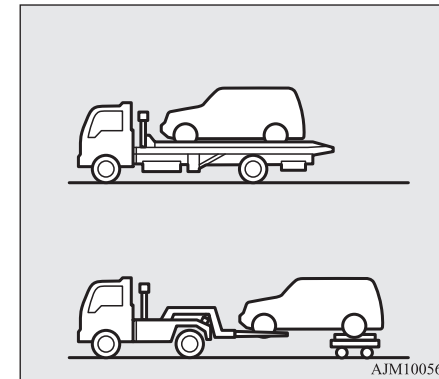

In the following cases, contact a MITSUBISHI MOTORS Authorized Service Point and transport the vehicle with all wheels on a carriage.

- The ready indicator illuminates but the vehicle does not move, or an abnormal noise is produced.
- A warning lamp in the meter illuminates.
- Inspection of the vehicle's underside reveals that oil or some other fluid is leaking.
- Your vehicle body is severely damaged or deformed in the event of an accident.

Towing

If a wheel gets stuck in a ditch, do not try to tow the vehicle.

Please contact your MITSUBISHI MOTORS Authorized Service Point or a commercial tow truck service for assistance.

Your vehicle may be temporarily towed by another vehicle with a rope in emergency situations such as running out of fuel.

If your vehicle is to be towed by another vehicle, carefully tow your vehicle for the shortest distance possible and in accordance with the instructions given in “Emergency towing” in this part.

The regulations concerning towing may differ from country to country. It is recommended that you obey the regulations of the area where you are driving your vehicle.

9

CAUTION

- If the drivetrain or suspension has a problem, do not tow the vehicle with only the rear wheels or front wheels placed on a dolly.

Towing the vehicle by a tow truck

WARNING

- Never get under your vehicle after it has been lifted by a tow truck.

WARNING

- Never ride in a vehicle that is being towed.
- Never tow the vehicle with front wheels and/or rear wheels on the ground. This may cause damage to the electric motors and transaxle.

WARNING

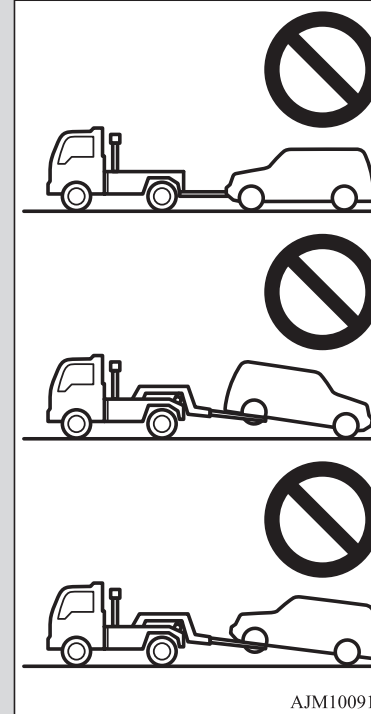

CAUTION

- Never tow the vehicle using a sling type truck.

⚠ CAUTION

Doing so will damage the bumper and/or body.

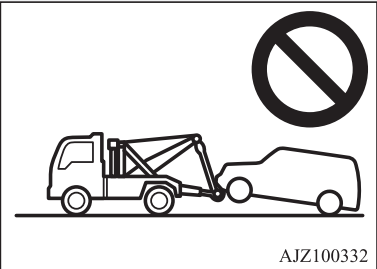

AJZ100332

Emergency towing

If your vehicle is temporarily towed by another vehicle with a rope in emergency situations such as running out of fuel, the towing distance should be as short as possible and tow carefully in accordance with the following procedure.

If your vehicle is to be towed by another vehicle

⚠ WARNING

- Never tow your vehicle in this method except in emergency situations such as running out of fuel. If the vehicle is towed in this method, a problem can occur in the vehicle damaging the motor, transaxle, etc. indicated by illuminating warning lamps.

1. The front towing hooks are located as shown in illustration. Secure the tow rope to the front towing hook.

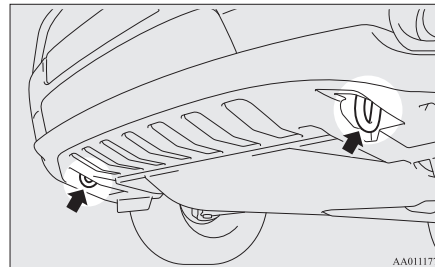

📖 NOTE

- Using any part other than the designated towing hook could result in damage to vehicle body.

📖 NOTE

- Using a wire rope or metal chain can result in damage to the vehicle body. It is best to use a non-metallic rope. If you use a wire rope or metal chain, wrap it with cloth at any point where it touches the vehicle body.
- Take care that the tow rope is kept as horizontal as possible. An angled tow rope can damage the vehicle body.
- Secure the tow rope to the same side towing hook, to keep the tow rope as straight as possible.

2. Start the Plug-in Hybrid EV system.
If the Plug-in Hybrid EV System cannot be started, put the operation mode of the power switch in “ON”.

⚠ WARNING

- If the vehicle is towed with the operation mode in “ON” without starting the Plugin Hybrid EV System, the auxiliary battery may be fully discharged during towing. In this case, the brake performance becomes very poor and the steering wheel becomes very heavy.

Towing

⚠ CAUTION

- For vehicle equipped with the Adaptive Cruise Control system (ACC) and Forward Collision Mitigation system (FCM), stop these systems to prevent an unexpected accident or unexpected operation during towing. Refer to “Adaptive Cruise Control system (ACC)” on page 7-55 and “Forward Collision Mitigation system (FCM)” on page 7-67.

3. Put the select position in “N” (NEUTRAL) position.
4. Turn on the hazard warning lamps if required by law. (Follow the local driving laws and regulations.)
5. During towing make sure that close contact is maintained between the drivers of both vehicles, and that the vehicles travel at low speed.

⚠ WARNING

- **Avoid sudden braking, acceleration and steering wheel movements; such driving operation could cause damage to the towing hook or tow rope.**
People in the vicinity could be injured as a result.
- **When going down a long slope, the brakes may overheat, reducing effectiveness.**
Have your vehicle transported by a tow truck.

⚠ CAUTION

- The person in the vehicle being towed must pay attention to the brake lamps of the towing vehicle and make sure the rope never becomes slack.
- When the vehicle is to be towed by another vehicle with all the wheels on the ground, make sure that the towing speed and distance given below are never exceeded, avoiding damage to the transaxle.

Towing speed: 30 km/h (19 mph)
Towing distance: 30 km

For the towing speed and the towing distance, follow the local driving laws and regulations.

If your vehicle tows another vehicle

Only use the rear towing hook as shown in the illustration.

Secure the tow rope to the rear towing hook. Otherwise, the instructions are the same as for “When being towed by another vehicle”.

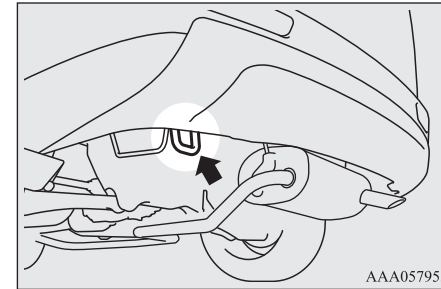

📖 NOTE

- Using any part other than the designated towing hook could result in damage to vehicle body.
- Do not tow a vehicle heavier than your own vehicle.

Operation under adverse driving conditions

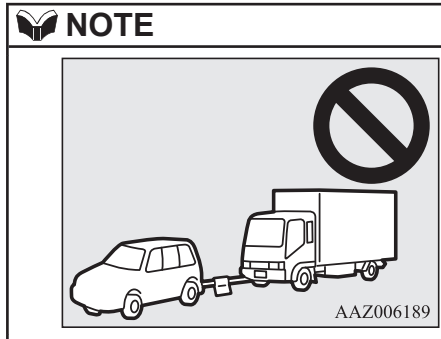

Operation under adverse driving conditions

E00801703828

If your vehicle becomes stuck in sand, mud or snow

If your vehicle becomes stuck in snow, sand, or mud, it can often be moved by a rocking motion. Rock your vehicle back and forth to free it.

Do not spin the wheels. Constant efforts to free a stuck vehicle can cause transaxle failure.

If your vehicle is still stuck after several rocking attempts, call for a commercial tow truck service.

WARNING

- When trying to rock your vehicle out of a stuck position, make sure that there are no people nearby. The rocking motion can make your vehicle suddenly lurch forward or backward, and injure any bystanders.

On a flooded road

- Do not drive on a flooded road. If you drive on a flooded road, not only does the Plug-in Hybrid EV System stop but there may be a failure like electric leakage or short circuit.

If you inevitably had to run on a flooded road and the vehicle was exposed to water, be sure to have your vehicle inspected by a MITSUBISHI MOTORS Authorized Service Point.

- If there is water on the brakes after driving through puddles or washing the vehicle, resulting in temporarily ineffective brakes. In such cases, lightly depress the brake pedal to see if the brakes operate properly. If they do not, lightly depress the pedal several times while driving in order to dry the brake pads.
- When driving in rain or on a road with many puddles a layer of water may form between the tyres and the road surface.

This reduces a tyre's frictional resistance on the road, resulting in loss of steering stability and braking capability.

To cope with this, observe the following items:

- A- Drive your vehicle at slow speed.
- B- Do not drive on worn tyres.
- C- Always maintain the specified tyre inflation pressures.

On a snow-covered or frozen road

- When driving on a snow-covered or frozen road, it is recommended that you use snow tyres or snow traction device (tyre chains). Refer to the "Snow tyres" and "Snow traction device (tyre chains)" sections.
- Avoid high-speed operation, sudden acceleration, abrupt brake application and sharp cornering.

9

Operation under adverse driving conditions

- Depressing the brake pedal during travel on snowy or icy roads may cause tyre slippage and skidding. When traction between the tyres and the road is reduced the wheels may skid and the vehicle cannot readily be brought to a stop by conventional braking techniques. Braking will differ, depending upon whether you have anti-lock brake system (ABS). As your vehicle is equipped with ABS, brake by pressing the brake pedal hard, and keeping it pressed.
- Allow extra distance between your vehicle and the vehicle in front of you, and avoid sudden braking.
- Accumulation of ice on the braking system can cause the wheels to lock. Pull away from a standstill slowly after confirming safety around the vehicle.

CAUTION

- Do not press the accelerator pedal rapidly. If the wheels break free of the ice, the vehicle could suddenly start moving and possibly cause an accident.

On a bumpy or rutted road

Drive as slow as possible when driving on bumpy or rutted roads.

CAUTION

- The impact on tyres and/or wheels when driving on a bumpy or rutted road can damage the tyre and/or wheel.

This vehicle is intended for driving mainly on roads with firm surface.

4WD system makes it possible to drive on roads without special coverage, on flat and firm surfaces. Please, remember that off-road ability of your vehicle is limited. Your vehicle is not intended for driving in heavy off-road terrain, overcoming the rugged terrain, deep ruts, etc.

The manufacturer of the vehicle is proceeding from the following assumption: if the driver makes the decision to keep driving under conditions mentioned above, he takes all actions at own risk, aware of the possible consequences.

Vehicle care

Vehicle care precautions.....10-02
Cleaning the interior of your vehicle..... 10-02
Cleaning the exterior of your vehicle.....10-03

Vehicle care precautions

Vehicle care precautions

E00900100548

In order to maintain the value of your vehicle, it is necessary to perform regular maintenance using the proper procedures.

Always maintain your vehicle in compliance with environmental pollution control regulations.

Carefully select the materials used for washing, etc., to be sure that they do not contain corrosives.

If in doubt, we recommend you to consult a specialist for selection of these materials.

10

CAUTION

- Cleaning products can be dangerous. Always follow the instructions of the cleaning product supplier.
- To avoid damage, never use the following to clean your vehicle,
 - Petrol
 - Paint Thinner
 - Benzine
 - Kerosene
 - Turpentine
 - Naphtha
 - Lacquer Thinner
 - Carbon Tetrachloride
 - Nail Polish Remover
 - Acetone

Cleaning the interior of your vehicle

E00900201823

After cleaning the interior of your vehicle with water, cleaner or similar, wipe and dry in a shady, well-ventilated area.

NOTE

- To clean the inside of the tailgate window, always use a soft cloth and wipe the window glass along the demister heater element so as not to cause damage.

CAUTION

- Do not use organic substances (solvents, benzine, kerosene, alcohol, petrol, etc.) or alkaline or acidic solutions. These chemicals can cause discolouring, staining or cracking of the surface. If you use cleaners or polishing agents, make sure their ingredients do not include the substances mentioned above.
- When cleaning the meter cluster panel, use a thick cloth and be careful not to injure your hands.

Plastic, vinyl leather, fabric and flocked parts

E00900301462

1. Lightly wipe these off with a soft cloth soaked in a mild soap and water solution.
2. Dip cloth in fresh water and wring it out well. Using this cloth, wipe off the detergent thoroughly.

NOTE

- Do not use cleaners, conditioners, and protectants containing silicons or wax. Such products can cause discolouring and when applied to the instrument panels or other parts, may cause reflections on the windscreen and obscure vision. Also, if such products get on the switches of the electrical accessories, it may lead to failure of these accessories.
- Do not use synthetic fiber or dry cloth. They can cause discolouring or damage the surface.
- Do not place a deodorizer on the instrument panel or near lamps and instruments. The ingredients for deodorizer can cause discolouring or cracking.

Upholstery

E00900500207

1. To maintain the value of your new vehicle, handle the upholstery carefully and keep the interior clean.
Use a vacuum cleaner and brush to clean the seats. If stained, vinyl and synthetic leather should be cleaned with an appropriate cleaner. Cloth fabrics can be cleaned with either upholstery cleaner or a mild soap and water solution.
2. Clean the carpeting with a vacuum cleaner and remove any stains with carpet cleaner. Oil and grease can be removed by lightly dabbing with a clean colourfast cloth and stain remover.

Genuine leather*

E00900600950

1. To clean, lightly wipe the leather with a soft cloth soaked in a mild soap and water solution.
2. Dip cloth in fresh water and wring it out well. Using this cloth, wipe off the detergent thoroughly.
3. Apply leather protecting agent to the genuine leather surface.

NOTE

- If genuine leather is wet with water or is washed in water, wipe off water as quickly as possible with a dry, soft cloth. If left damp, mildew may grow.
- Organic solvents such as benzine, kerosene, alcohol and petrol, acid or alkaline solvents may discolour the genuine leather surface. Be sure to use neutral detergents.
- Remove dirty patches or oil substances quickly as they can stain genuine leather.
- The genuine leather surface may harden and shrink if it is exposed to direct sun for long hours. When your vehicle is parked, place it in the shade as much as possible.
- When the temperature of the vehicle interior rises in summer, vinyl products left on the genuine leather seat may deteriorate and stick to the seat.

Cleaning the exterior of your vehicle

E00900700108

If the following is left on your vehicle, it may cause corrosion, discolouration and stains, wash the vehicle as soon as possible.

- Seawater, road deicing products.
- Soot and dust, iron powder from factories, chemical substance (acids, alkalis, coaltar, etc.).
- Droppings from birds, carcasses of insects, tree sap, etc.

Washing

E00900904267

Chemicals contained in the dirt and dust picked up from the road surface can damage the paint coat and body of your vehicle if left in prolonged contact.

Frequent washing and waxing is the best way to protect your vehicle from this damage. This will also be effective in protecting it from environmental elements such as rain, snow, salt air, etc.

Do not wash the vehicle in direct sunlight. Park the vehicle in the shade and spray it with water to remove dust. Next, using an ample amount of clean water and a car washing brush or sponge, wash the vehicle from top to bottom.

Use a mild car washing soap if necessary. Rinse thoroughly and wipe dry with a soft cloth. After washing the vehicle, carefully clean the joints and flanges of the doors, bonnet and other sections where dirt is likely to remain.

10

WARNING

- Do not wash the vehicle while charging the traction battery. Doing so could cause fire or an electric shock.

Cleaning the exterior of your vehicle

WARNING

- Before washing the vehicle, make sure that the charging lid and the inner lid are completely closed. If the lid is open, the charging unit is exposed to water, resulting in fire or an electric shock.

CAUTION

- When washing the under side of your vehicle or wheel, be careful not to injure your hands.
- As your vehicle is equipped with the rain sensor, place the wiper switch lever in the “OFF” position to deactivate the rain sensor before washing the vehicle. Otherwise, the wipers will operate in the presence of water spray on the windscreen and may get damaged as a result.
- Refrain from excessively using a car wash as its brushes may scratch the paint surface, causing it to lose its gloss. Scratches will be especially visible on darker coloured vehicles.
- Never spray or splash water on the electrical components in the engine compartment. Doing so could have an adverse effect on the Plug-in Hybrid EV system startability. Exercise caution also when washing the underbody; be careful not to spray water into the engine compartment.
- Some types of hot water washing equipment apply high pressure and heat to the vehicle. They may cause heat distortion and damage

CAUTION

to the vehicle resin parts and may result in flooding of the vehicle interior.

Therefore:

- Maintain a distance of approx. 70 cm or more between the vehicle body and the washing nozzle.
- When washing around the door glass, hold the nozzle at a distance of more than 70 cm and at right angles to the glass surface.
- After washing the vehicle, drive the vehicle slowly while lightly depressing the brake pedal several times in order to dry out the brakes. Leaving the brakes wet could result in reduced braking performance. Also, there is a possibility that they could freeze up or become inoperative due to rust, rendering the vehicle unable to move.
- When using an automatic car wash, pay attention to the following items, referring to the operation manual or consulting a car wash operator. If the following procedure is not followed, it could result in damage to your vehicle.
 - The outside mirrors are retracted.
 - The wiper arms are secured in place with tape.
 - If your vehicle is equipped with roof rails or a roof spoiler, consult a car wash operator before using the car wash.
 - As your vehicle is equipped with the rain sensor, place the wiper switch lever in the “OFF” position to deactivate the rain sensor.

CAUTION

- Make sure that the charging lid and the fuel lid are completely closed.
- If your vehicle is equipped with the Ultrasonic misacceleration Mitigation System (UMS), turn the system off by using the “FCM and UMS ON/OFF switch” on page 7-72.

During cold weather

Salt and other chemicals spread on the roads in some areas in winter can have a harmful effect on the vehicle body. You should therefore wash the vehicle as often as possible in accordance with our care-instructions. It is recommended to have a preservative applied and the underfloor protection checked before and after the cold weather season.

After washing your vehicle, wipe off all waterdrops from the rubber parts around the doors to prevent the doors from freezing.

NOTE

- To prevent freezing of the weatherstripping on the doors, bonnet, etc., they should be treated with silicone spray.

Waxing

E00901000919

Waxing the vehicle will help prevent the adherence of dust and road chemicals to the paintwork. Apply a wax solution after washing the vehicle, or at least once every three months to assist displacing of water.

Do not wax your vehicle in direct sunlight. You should wax after the surfaces have cooled.

For information on how to use wax refer to the instruction manual of the wax.

⚠ CAUTION

- Waxes containing high abrasive compounds should not be used.
- On vehicles with a sunroof, be careful when waxing the area around the sunroof opening, not to put any wax on the weatherstrip (black rubber). If stained with wax, the weatherstrip cannot maintain a weatherproof seal with the sunroof.

Polishing

E00901100066

The vehicle should only be polished if the paintwork has become stained or lost its lustre. Do not polish parts with a mat coating and the plastic bumpers. Doing so could cause stains or damage the finish.

Cleaning plastic parts

E00901300808

Use a sponge or chamois leather.

If a car wax adheres on a grey or black rough surface of the bumper, moulding or lamps, the surface becomes white. In such a case, wipe it off using lukewarm water and soft cloth or chamois leather.

⚠ CAUTION

- Do not use a scrubbing brush or other hard tools as they may damage the plastic part surface.
- Do not bring the plastic parts into contact with petrol, light oil, brake fluids, engine oils, greases, paint thinners, and sulphuric acid (battery electrolyte) which may crack, stain or discolour the plastic parts. If they touch the plastic parts, wipe them off with soft cloth, chamois or the like and an aqueous solution of neutral detergent then immediately rinse the affected parts with water.

Chrome parts

E00901400098

In order to prevent spots and corrosion of chrome parts, wash with water, dry thoroughly, and apply a special protective coating. This should be done more frequently in winter.

Aluminium wheels

E00901501676

1. Remove dirt using a sponge while sprinkling water on the wheels.
2. Use neutral detergent on any dirt that cannot be removed easily with water. Rinse off the neutral detergent after washing the wheels.
3. Dry the wheels thoroughly using a chamois leather or a soft cloth.

⚠ CAUTION

- Do not use a brush or other hard implement on the wheels. Doing so could scratch the wheels.
- Do not use any cleaner that contains an abrasive substance or is acidic or alkaline. Doing so could cause the coating on the wheels to peel or become discoloured or stained.
- Do not directly apply hot water using a steam cleaner or by any other means.
- Contact with seawater and road deicer can cause corrosion. Rinse off such substances as soon as possible.

Window glass

E00901600117

The window glass can normally be cleaned using only a sponge and water.

Cleaning the exterior of your vehicle

Glass cleaner can be used to remove oil, grease, insect carcasses, etc. After washing the glass, wipe it dry with a clean, dry, soft cloth. Never use a cloth that is used for cleaning a painted surface to clean a window. Wax from the painted surface could get on the glass and lower glass transparency and visibility.

NOTE

- To clean the inside of the rear window, always use a soft cloth and wipe the window glass along the demister heater element so as not to cause damage.

10

Wiper blades

E00901701144

Use a soft cloth and glass cleaner to remove grease, dead insects, etc., from the wiper blades. Replace the wiper blades when they no longer wipe properly. (Refer to page 11-14.)

Cleaning the sunroof*

E00902200051

Use a soft cloth to clean the inner side of the sunroof. Hard deposits should be wiped away with a cloth dipped in warm, neutral detergent solution. Wipe away the solution with a sponge dipped in fresh water.

NOTE

- The surface treatment on the inside of the glass may be removed if hard cloth or organic solvent (benzine, kerosene, thinner, etc.) is used.

Engine compartment

E00902101565

Clean the engine compartment at the beginning and end of winter. Pay particular attention to flanges, crevices and peripheral parts where dust containing road chemicals and other corrosive materials might collect.

If salt and other chemicals are used on the roads in your area, clean the engine compartment at least every 3 months.

Never spray or splash water on the electrical components in the engine compartment, as this may cause damage.

Do not bring the nearby parts, the plastic parts and so on into contact with sulphuric acid (battery electrolyte) which may crack, stain or discolour them.

If they are in contact, wipe off with soft cloth, chamois or the like and an aqueous solution of neutral detergent then immediately rinse the affected parts with plenty of water.

Maintenance

Service precautions.....	11-02
Catalytic converter.....	11-03
Bonnet.....	11-04
Engine oil.....	11-05
Engine coolant/Plug-in hybrid EV system coolant.....	11-06
Washer fluid.....	11-08
Brake fluid.....	11-08
Auxiliary battery.....	11-09
Tyres.....	11-10
Wiper blade rubber replacement.....	11-14
General maintenance.....	11-16
Fusible links.....	11-16
Fuses.....	11-16
Replacement of lamp bulbs.....	11-24

Service precautions

Service precautions

E01000102713

Adequate care of your vehicle at regular intervals serves to preserve the value and appearance as long as possible.

Maintenance items as described in this owner's manual can be performed by the owner.

We recommend you to have the periodic inspection and maintenance performed by a MITSUBISHI MOTORS Authorized Service Point or another specialist.

In the event a malfunction or a problem is discovered, we recommend you to have it checked and repaired. This section contains information on inspection maintenance procedures that you can do yourself. Follow the instructions and cautions for each of the various procedures.

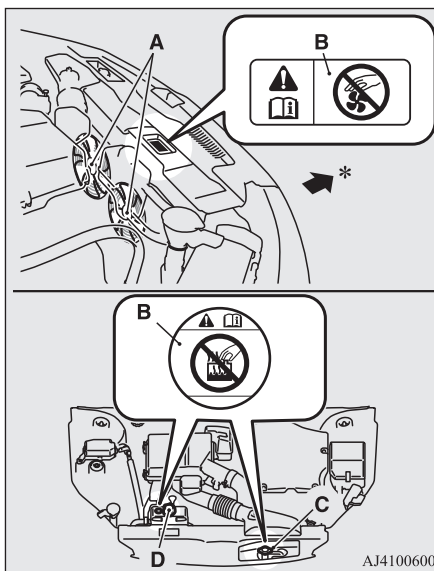

- A- Cooling fans
- B- Caution label
- C- Radiator cap

D- EV cooling reserve tank cap

*: Front of the vehicle

⚠ WARNING

- Before performing inspection or maintenance, be sure to disconnect the normal charge connector from the vehicle and confirm that the operation mode of the power switch is set to "OFF".
- Never touch the high-voltage parts in the engine compartment. Never remove or disassemble the high-voltage components, cables (orange) or connectors. Also, never disassemble normal charging cables, normal charge connector, plugs or outlet. Failure to observe this instruction could cause an electric shock which can result in a serious injury or death. These parts have labels that indicate handling precautions. Follow the instruction on these labels. Contact a MITSUBISHI MOTORS Authorized Service Point for any necessary maintenance. Refer to "High-Voltage components" on page 2-08.
- When checking or servicing the inside of the engine compartment, make sure the plug-in hybrid EV system is switched off and has had a chance to cool down.

⚠ WARNING

- If it is necessary to do work in the engine compartment with the plug-in hybrid EV system starting, be especially careful that your clothing, hair, etc., does not become caught by the cooling fans, drive belts, or other moving parts.
- After performing the maintenance, make sure that no tools or cloths are left behind in the engine compartment. If they are left behind, a fire or damage to the vehicle may occur.
- The cooling fans can turn on automatically even if the plug-in hybrid EV system is stopping. Put the operation mode of the power switch in OFF to be safe while you work in the engine compartment.
- Make sure that the engine and Plug-in Hybrid EV system has cooled down before removing the radiator cap and EV cooling system reserve tank cap, because hot steam or boiling water will otherwise gush from the filler port and may scald you.
- Do not smoke, cause sparks or allow open flames around fuel or auxiliary battery. The fumes are flammable.
- Be extremely cautious when working around the auxiliary battery. It contains poisonous and corrosive sulphuric acid.
- Do not get under your vehicle with just the body jack supporting it. Always use automotive jack stands.

⚠ WARNING

- Improper handling of components and materials used in the vehicle can endanger your personal safety. We recommend you to consult a specialist for necessary information.
- The components inside the engine room might be very hot to the touch. To avoid being burnt, make sure all components have sufficiently cooled before beginning an inspection. These components are affixed with the label indicating precautions for handling. Follow the instructions on the label.

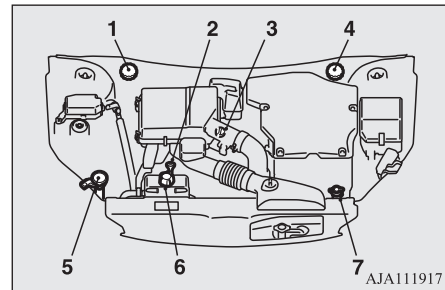

- 1- Brake fluid reservoir (RHD)
- 2- Engine oil level dipstick
- 3- Engine oil cap
- 4- Brake fluid reservoir (LHD)
- 5- Washer fluid reservoir
- 6- EV cooling system reservoir
- 7- Engine coolant reservoir

Catalytic converter

E01000202495

The exhaust gas scavenging devices used with the catalytic converter are extremely efficient for the reduction of noxious gases. The catalytic converter is installed in the exhaust system.

It is important to keep the engine properly tuned to ensure proper catalyst operation and prevent possible catalyst damage.

⚠ WARNING

- As with any vehicle, do not park or operate this vehicle in areas where combustible materials such as dry grass or leaves can come in contact with a hot exhaust since a fire could occur.
- Paint should not be applied to the catalytic converter.

📖 NOTE

- Use fuel of the type recommended in "Fuel selection" on page 2-14.

Bonnet

Bonnet

E01000304689

To open

1. Pull the release lever towards you to unlock the bonnet.

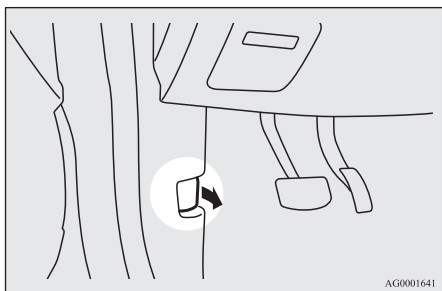

11

2. Raise the bonnet while pressing the safety lock.

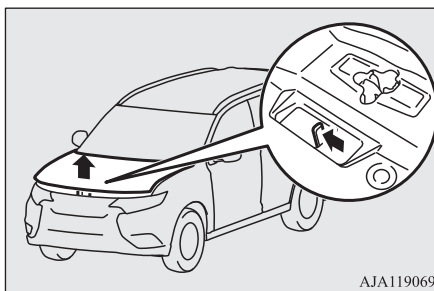

NOTE

- Only open the bonnet when the wipers are in the original position. In any other position, the wipers could damage the paint or bonnet.

3. Support the bonnet by inserting the support bar in its slot.

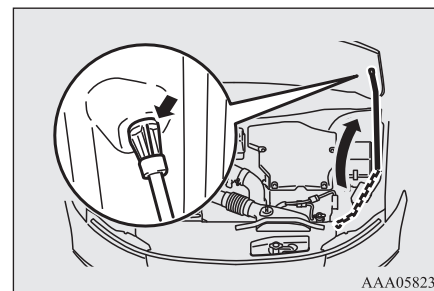

CAUTION

- Note that the support bar may disengage the bonnet if the open bonnet is lifted by a strong wind.
- After inserting the support bar into the slot, make sure the bar supports the bonnet securely from falling down on to your head or body.

To close

1. Unlatch the support bar and clip it in its holder.
2. Slowly lower the bonnet to a position about 20 cm above the closed position, then let it drop.

3. Make sure the bonnet is securely locked by softly lifting the centre of the bonnet.

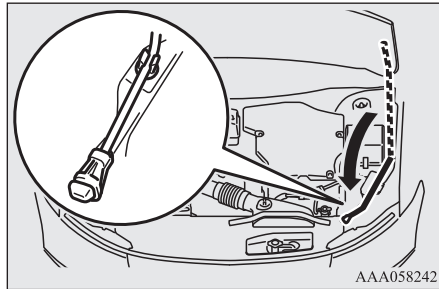

CAUTION

- Be careful that hands or fingers are not trapped when closing the bonnet.
- Before driving, make sure that the bonnet is securely locked. An incompletely locked bonnet can suddenly open while driving. This can be extremely dangerous.

NOTE

- If this does not close the bonnet, release it from a slightly higher position.
- Do not press down firmly on the bonnet as doing so could damage it.

NOTE

- For vehicles equipped with the security alarm system, if you drive with the bonnet left open, a warning display is displayed on the information screen in the multi information display.



Engine oil

E01000405094

To check and refill engine oil

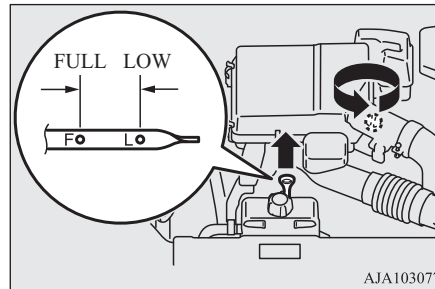

The engine oil used has a significant effect on the engine's performance, service life and startability. Be sure to use oil of the recommended quality and appropriate viscosity.

All engines consume a certain amount of oil during normal operation. Therefore, it is important to check the oil level at regular intervals or before starting a long trip.

1. Park the vehicle on a horizontal surface.
2. Switch off the engine.
3. Wait a few minutes.
4. Remove the dipstick and wipe it with a clean cloth.
5. Reinsert the dipstick as far as it goes.
6. Remove the dipstick and read the oil level, which should always be within the range indicated.
7. If the oil level is below the specified limit, remove the cap located on the cylinder head cover and add enough oil to raise the level to within the specified range. Do not overfill to avoid engine damage. Be sure to use the specified engine oil and do not mix various types of oil.
8. After adding oil, close the cap securely.
9. Confirm the oil level by repeating step 4 to 6.

Engine coolant/Plug-in hybrid EV system coolant

NOTE

- The engine oil will deteriorate rapidly if the vehicle is subjected to severe conditions, requiring earlier oil replacement. Please refer to the maintenance schedule.
- For information on how to dispose of used engine oil, refer to page 2-18.

Recommended engine oil viscosity

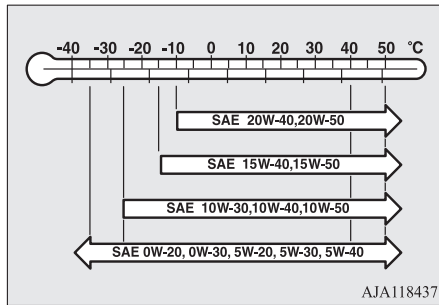

11

- Select engine oil of the proper SAE viscosity number according to the atmospheric temperature. SAE 0W-20, 0W-30, 5W-20, 5W-30, and 5W-40 engine oils can only be used if they meet ACEA A3/B3, A3/B4 or A5/B5 and API SM (or higher) specifications.
- Use engine oil conforming to the following classification:

11-06 Maintenance

- API classification: “For service SM” or higher
- ILSAC certificated oil
- ACEA classification: “For service A1/B1, A3/B3, A3/B4 or A5/B5”

NOTE

- Use of additives is not recommended since they may reduce the effectiveness of additives already included in the engine oil. It may result in failure of the mechanical assembly.

Engine coolant/Plug-in hybrid EV system coolant

E01000503466

To check the coolant level

A transparent engine coolant reserve tank (A) and EV cooling system reserve tank (B) is located in the engine compartment.

The coolant level in this tank should be kept between the “LOW” and “FULL” marks when measured while the engine and the plug-in hybrid EV system are cold.

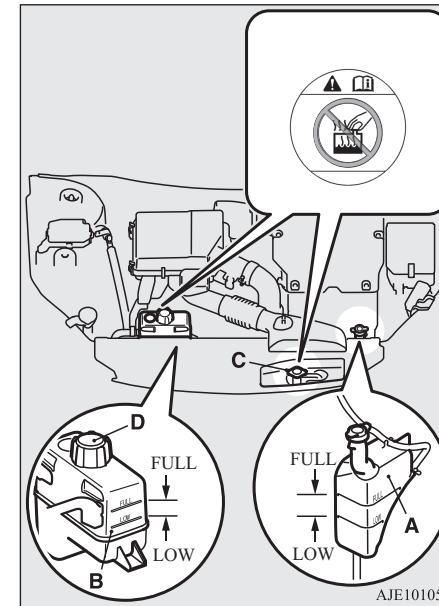

OGGE19E1

To add coolant

The cooling system is a closed system and normally the loss of coolant should be very slight. A noticeable drop in the coolant level could indicate leakage. If this occurs, we recommend you to have the system checked as soon as possible.

If the level should drop below the “LOW” level on the reserve tank, open the lid and add coolant.

Also, if the reserve tank is completely empty, remove the radiator cap (C) or the reserve tank cap (D) and add coolant until the level reaches the filler neck.

WARNING

- Do not open the radiator cap (C) and the reserve tank cap (D) while the engine and the plug-in hybrid EV system are hot. The coolant system is under pressure and any hot coolant escaping could cause severe burns.

Anti-freeze

The engine coolant and the plug-in hybrid EV system coolant contains an ethylene glycol anti-corrosion agent. Some parts of the engine and the plug-in hybrid EV system are cast aluminium alloy, and periodic changing of the engine coolant and the plug-in hybrid EV system coolant are necessary to prevent corrosion of these parts.

Use “MITSUBISHI MOTORS GENUINE SUPER LONG LIFE COOLANT PREMIUM” or equivalent*.

MITSUBISHI MOTORS GENUINE Coolant has excellent protection against corrosion and rust formation of all metals including aluminium and can avoid blockages in the radiator, heater, cylinder head, engine block, etc.

Because of the necessity of this anti-corrosion agent, the coolant must not be replaced with plain water even in summer. The required concentration of anti-freeze differs depending on the expected ambient temperature.

Above -35 °C: 50 % concentration of anti-freeze

*similar high quality ethylene glycol based non-silicate, non-amine, non-nitrate and non-borate coolant with long life hybrid organic acid technology

Below -35 °C: 60 % concentration of anti-freeze

CAUTION

- Do not use alcohol or methanol anti-freeze or any engine coolants mixed with alcohol or methanol anti-freeze. The use of an improper anti-freeze can cause corrosion of the aluminium components.
- Do not use water to adjust the concentration of coolant.
- Concentrations exceeding 60 % will result in a reduction of both the anti-freeze and cooling performance thus adversely affecting the engine.
- Do not top up with water only. Water by itself reduces the rust-protective and anti-freeze qualities of the coolant and has a lower boiling point. It can also cause damage to the cooling system if it should freeze. Do not use tapwater, as it can cause corrosion and rust formation.

During cold weather

If the temperatures in your area drop below freezing, there is the danger that the coolant in the engine, plug-in hybrid EV system or radiator could freeze and cause severe damage to the engine and/or radiator. Add a sufficient amount of anti-freeze to the coolant to prevent it from freezing.

Washer fluid

The concentration should be checked before the start of cold weather and anti-freeze added to the system if necessary.

Washer fluid

E01000702214

Open the washer fluid reservoir cap and check the level of washer fluid with the dipstick.

If the level is low, replenish the container with washer fluid.

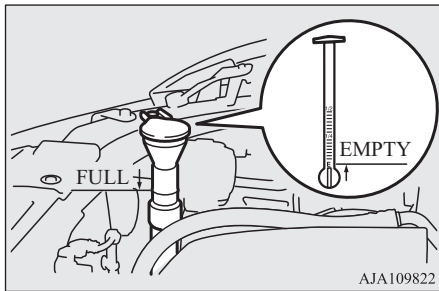

11

NOTE

- The washer fluid container serves the wind-screen, rear window and headlamps.

During cold weather

To ensure proper operation of the washers at low temperatures, use a fluid containing an anti-freezing agent.

Brake fluid

E01000801827

To check the fluid level

The fluid level must be between the "MAX" and "MIN" marks on the reservoir.

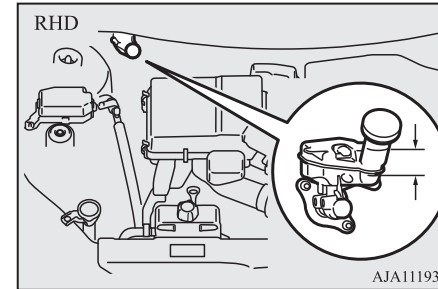
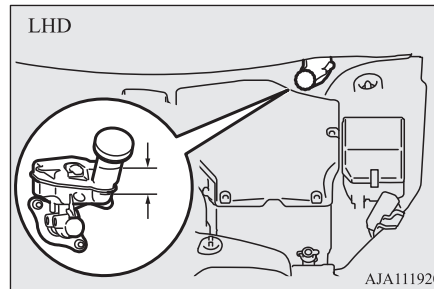

The fluid level is monitored by a float. When the fluid level falls below the "MIN" mark, the brake fluid warning lamp lights up.

The fluid level falls slightly with wear of the brake pads, but this does not indicate any abnormality.

The fluid in the master cylinder should be checked when doing other work under the bonnet. The brake system should also be checked for leakage at the same time.

If the fluid level falls markedly in a short length of time, it indicates leaks from the brake system.

If this occurs, we recommend you to have the vehicle checked.

Fluid type

Use brake fluid conforming to DOT3 or DOT4 from a sealed container. The brake fluid is hygroscopic. Too much moisture in the brake fluid will adversely affect the brake system, reducing the performance.

WARNING

- Take care in handling brake fluid as it is harmful to the eyes, may irritate your skin and will damage painted surfaces. Wipe up any spills immediately. If brake fluid gets on your hand or in your eyes, flush immediately with clean water. Follow up with a doctor as necessary.

CAUTION

- Use only the specified brake fluid. Do not mix or add different brands of brake fluid to prevent chemical reactions. Do not let any petroleum-based fluid touch, mix with, or get into the brake fluid. This will damage the seals.
- Keep the reservoir tank cap closed to prevent the brake fluid from deteriorating except maintenance.
- Clean the filler cap before removing and close the cap securely after maintenance.

Auxiliary battery

E01001203864

The condition of the auxiliary battery is very important for quick starting of the plug-in hybrid EV system and proper functioning of the vehicle's electrical system. Regular inspection is especially important in cold weather. Be sure to have a MITSUBISHI MOTORS Authorized Service Point check the auxiliary battery.

WARNING

- Be sure to have a MITSUBISHI MOTORS Authorized Service Point charge the battery. Do not charge the battery yourself. Flammable gases may leak and explode.

CAUTION

- There is a type of auxiliary battery is not properly installed in the vehicle, even if the same specification. When replacing the auxiliary battery, please contact a MITSUBISHI MOTORS Authorized Service Point.

NOTE

- When the auxiliary battery is removed, the controlling timer for forcibly starting the engine may be reset. Since a fuel injection device may cause a clogging if the state where the engine does not operate continues after reset of the timer, please select the battery charge mode in order to start the engine. However, if the drive battery level is nearly full, the engine may not start even though the battery charge mode is selected. In that case, activate the battery charge mode again after the drive battery quantity decreases. Refer to "SAVE/CHARGE mode switch" on page 7-28.
- When the auxiliary battery is removed, since the timer control of the MITSUBISHI Remote Control is reset and the drive battery temperature control cannot be used, communicate the wireless LAN device and your vehicle again.
- When the auxiliary battery is removed, the timer control of the MITSUBISHI Remote Control is reset and each function of the MITSUBISHI Remote Control cannot be used. Also the drive battery cannot be warmed up. Communicate the wireless LAN device and your vehicle again.

Tyres

Tyres

E01001300255

WARNING

- Driving with tyres that are worn, damaged or improperly inflated can lead to a loss of control or blow out of the tyres which can result in a collision with serious or fatal injury.

Tyre inflation pressures

E01001404472

Tyre size	Front	Rear
215/70R16 100H	2.4 bar (35 psi) [240 kPa], 2.6 bar (38 psi) [260 kPa]*	
225/55R18 98H	2.4 bar (35 psi) [240 kPa], 2.6 bar (38 psi) [260 kPa]*	

11

*: Above 160 km/h (99 mph)

Check the tyre inflation pressure of all the tyres while they are cold; if insufficient or excessive, adjust to the specified value. After the tyre inflation pressure has been adjusted, check the tyres for damage and air leaks. Be sure to put caps on the valves.

NOTE

- The tyres that can be installed on your vehicle are shown on the driver's door label. For details, contact a MITSUBISHI MOTORS Authorized Service Point.

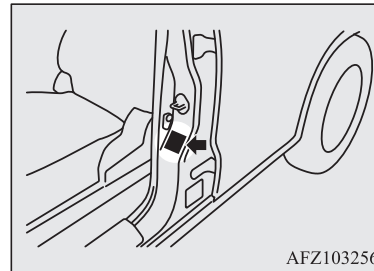

Wheel condition

E01001801970

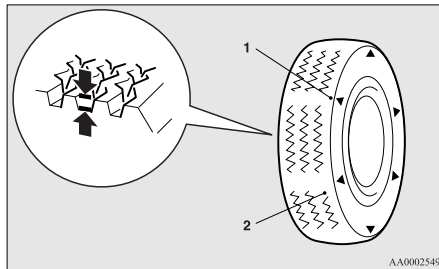

- 1- Location of the tread wear indicator
- 2- Tread wear indicator

Check the tyres for cuts, cracks and other damage. Replace the tyres if there are deep cuts or cracks. Also check each tyre for pieces of metal or pebbles.

The use of worn tyres can be very dangerous because of the greater chance of skidding or hydroplaning. The tread depth of the tyres must exceed 1.6 mm in order for the tyres to meet the minimum requirement for use.

Tread wear indicators will appear on the surface of the tyre as the tyre wears, thereby indicating that the tyre no longer meets the minimum requirement for use. When these wear indicators appear, the tyres must be replaced with new ones.

When replacement of any of the tyres is necessary, replace all of them.

OGGE19E1

CAUTION

- Always use tyres of the same size, same type, and same brand, and which have no wear differences. Using tyres of different size, type, brands or degree of wear, will increase the differential oil temperature, resulting in possible damage to the driving system. Further, the drive train will be subjected to excessive loading, possibly leading to oil leakage, component seizure, or other serious faults.

Tyres

Replacing tyres and wheels

E01007201820

CAUTION

- Avoid using different size tyres from the one listed and the combined use of different types of tyres, as this can affect driving safety. Refer to “Tyres and wheels” on page 12-09.
- Even if a wheel has the same rim size and offset as the specified type of wheel, its shape may prevent it from being fitted correctly. We recommend you to consult a specialist before using wheels that you have.
- As your vehicle is equipped with a tyre pressure monitoring system, only MITSUBISHI MOTORS GENUINE wheels should be used. Use of another type of wheel risks air leaks and sensor damage, as it will not be possible to install the tyre pressure sensor properly. Refer to “Tyre pressure monitoring system (TPMS)” on page 7-92.

11

NOTE

- A steel wheel with diameter of 16 inches cannot be used on your vehicle because it interferes with brake parts. Additionally, an aluminium wheel with diameter of 16 inches may not be used on your vehicle depending on its type, even if a MITSUBISHI MOTORS GENUINE wheel. Consult a MITSUBISHI MOTORS Authorized Service Point before using wheels that you have.

Tyre rotation

E01001902516

Tyre wear varies with vehicle conditions, road surface conditions and individual driver's driving habits. To equalize the wear and help extend tyre life, it is recommended to rotate the tyres immediately after discovery of abnormal wear, or whenever the wear difference between the front and rear tyres is recognizable.

When rotating tyres, check for uneven wear and damage. Abnormal wear is usually caused by incorrect tyre pressure, improper wheel alignment, out of balance wheel, or severe braking. We recommend you to have it checked to determine the cause of irregular tread wear.

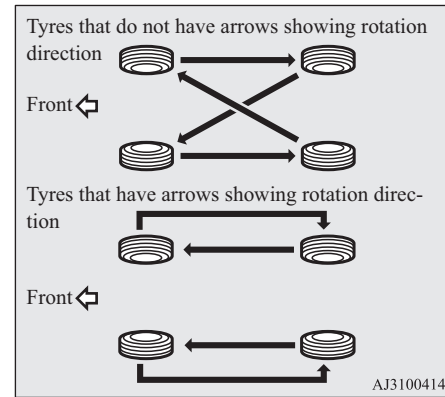

⚠ CAUTION

- If the tyres have arrows (A) indicating the correct direction of rotation, swap the front and rear tyres on the left-hand side of the vehicle and the front and rear tyres on the right-hand side of the vehicle separately. Keep each tyre on its original side of the vehicle. When fitting the tyres, make sure the arrows point in the direction in which the wheels will turn when the vehicle moves forward. Any tyre whose arrow points in the wrong direction will not perform to its full potential.

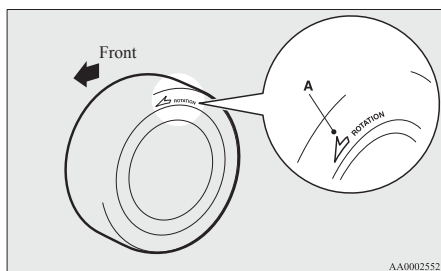

⚠ CAUTION

- Avoid the combined use of different types of tyres. Using different types of tyres can affect vehicle performance and safety.

Snow tyres

E01002001979

The use of snow tyres is recommended for driving on snow and ice. To preserve driving stability, mount snow tyres of the same size and tread pattern on all 4 wheels. A snow tyre that is worn down more than 50% is no longer appropriate to use. Snow tyres which do not meet specifications must not be used.

⚠ CAUTION

- Observe permissible maximum speed for your snow tyres and the legal speed limit.
- As your vehicle is equipped with a tyre pressure monitoring system, only MITSUBISHI Motors genuine wheels should be used. Use of another type of wheel risks air leaks and sensor damage, as it will not be possible to install the tyre pressure sensor properly. Refer to “Tyre pressure monitoring system (TPMS)” on page 7-92.

📖 NOTE

- The laws and regulations concerning snow tyres (driving speed, required use, type, etc.) vary. Find out and follow the laws and regulations in the area you intend to drive.
- If flange nuts are used on your vehicle, change to tapered nuts when steel wheels are used.

Snow traction device (tyre chains)

E01002103336

If snow traction device (tyre chains) have to be used, ensure that they are fitted only on the drive wheels (front) in accordance with the manufacturer’s instructions.

On 4WD vehicles in which the driving power is distributed preferentially to the front wheels, ensure that the snow traction device (tyre chains) are fitted on the front.

Use only snow traction device (tyre chains) which are designed for use with the tyres mounted on the vehicle: use of the incorrect size or type of snow traction device (tyre chains) could result in damage to the vehicle body.

Contact a MITSUBISHI MOTORS Authorized Service Point before putting on a snow traction device (tyre chains). The max. snow traction device (tyre chains) height is as follows.

11

Tyre size	Wheel size	Max. snow traction device (tyre chains) height [mm]
215/70R16 100H	16 x 6 1/2 J	9 mm

Wiper blade rubber replacement

Tyre size	Wheel size	Max. snow traction device (tyre chains) height [mm]
225/55R18 98H	18x7 J	9 mm

When driving with a snow traction device (tyre chains) on the tyres, do not drive faster than 50 km/h (30 mph). When you reach roads that are not covered in snow, immediately remove the snow traction device (tyre chains).

⚠ CAUTION

- Choose a clear straight stretch of road where you can pull off and still be seen while you are fitting the snow traction device (tyre chains).
- Do not fit snow traction device (tyre chains) before you need them. This will wear out your snow traction device (tyre chains) and the road surface.
- After driving around for 100-300 meters, stop and retighten the snow traction device (tyre chains).
- Drive carefully and do not exceed 50 km/h (30 mph). Remember that preventing accidents is not the purpose of snow traction device (tyre chains).
- When snow traction device (tyre chains) are installed, take care that they do not damage the disc wheel or body.

⚠ CAUTION

- An aluminium wheel can be damaged by a snow traction device (tyre chains) while driving. When fitting a snow traction device (tyre chains) on an aluminium wheel, take care that any part of the snow traction device (tyre chains) and fitting cannot be brought into contact with the wheel.
- When installing or removing a snow traction device (tyre chains), take care that hands and other parts of your body and not injured by the sharp edges of the vehicle body.

📖 NOTE

- The laws and regulations concerning the use of snow traction device (tyre chains) vary. Always follow local laws and regulations. In most countries, it is prohibited by the law to use of snow traction device (tyre chains) on roads without snow.

Wiper blade rubber replacement

E01002600532

Windscreen wiper blades

1. Lift the wiper arm off the windscreen.
2. Pull the wiper blade until its stopper (A) disengages from the hook (B). Then, pull the wiper blade further to remove it.

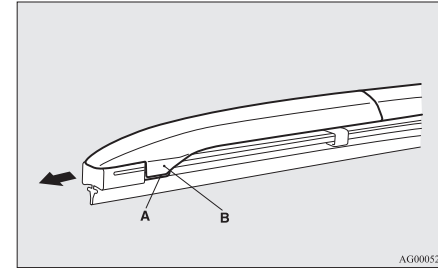

AG0005274

📖 NOTE

- Do not allow the wiper arm to fall onto the windscreen; it could damage the glass.

3. Attach the retainers (C) to a new wiper blade.

Wiper blade rubber replacement

Refer to the illustration to ensure that the retainers are correctly aligned as you attach them.

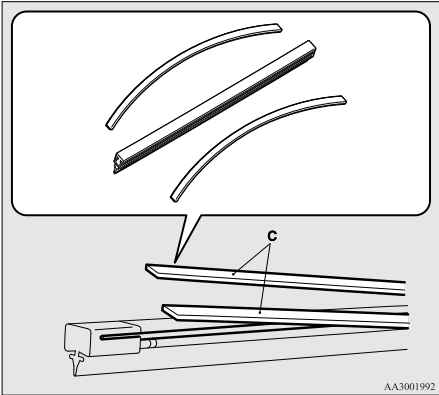

4. Insert the wiper blade into the arm, starting with the opposite end of the blade from the stopper. Make sure the hook (B) is fitted correctly in the grooves in the blade.

NOTE

- If retainers are not supplied with the new wiper blade, use the retainers from the old blade.

5. Push the wiper blade until the hook (B) engages securely with the stopper (A).

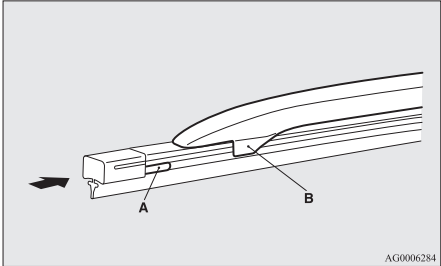

Rear window wiper blades

1. Lift the wiper arm off the window glass.
2. Pull the wiper blade downward to disengage it from the stopper (A) at the end of the wiper arm. Pull the wiper blade further to remove it.
3. Slide a new wiper blade through the hook (B) on the wiper arm.

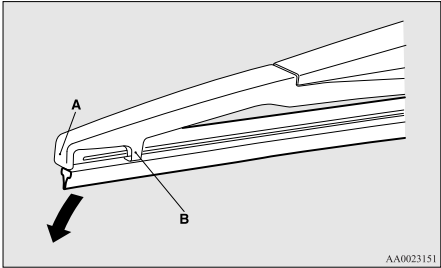

OGGE19E1

NOTE

- Do not allow the wiper arm to fall onto the window glass; it could damage the glass.

4. Firmly insert the retainer (C) into the groove (D) in the wiper blade. Refer to the illustration to ensure that the retainers are correctly aligned as you insert them into the groove.

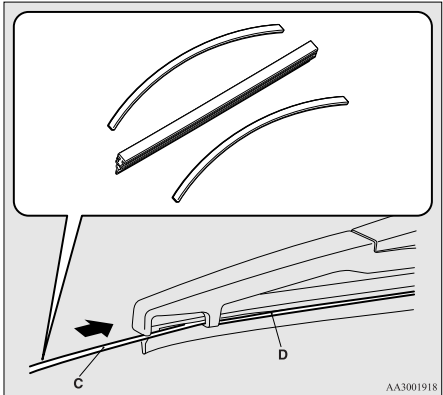

NOTE

- If a retainer is not supplied with the new wiper blade, use the retainer from the old blade.

General maintenance

General maintenance

E01002701556

Fuel, engine coolant, oil and exhaust gas leakage

Look under the body of your vehicle to check for fuel, engine coolant, oil and exhaust gas leaks.

WARNING

- If you see a suspicious fuel leak or if you smell fuel, do not operate the vehicle; call your MITSUBISHI MOTORS Authorized Service Point for assistance.

11

Exterior and interior lamp operation

Operate the combination lamp switch to check that all lamps are functioning properly. If the lamps do not illuminate, the probable cause is a blown fuse or defective lamp bulb. Check the fuses first. If there is no blown fuse, check the lamp bulbs.

For information regarding the inspection and replacement of the fuses and the bulbs, refer to “Fuses” on page 11-16 and “Replacement of lamp bulbs” on page 11-24.

If the fuses and bulbs are all OK, we recommend you to have your vehicle checked and repaired.

Meter, gauge and indicator/warning lamps operation

Start the plug-in hybrid EV system and check the operation of all instruments, gauges and indication and warning lamps.

If there is anything wrong, we recommend you to have your vehicle inspected.

Hinges and latches lubrication

Check all latches and hinges, and, if necessary, have them lubricated.

Fusible links

E01002901633

The fusible links will melt to prevent a fire if a large current attempts to flow through certain electrical systems.

In case of a melted fusible link, we recommend you to have your vehicle inspected.

For the fusible links, please refer to “Passenger compartment fuse location table” on page 11-19 and “Engine compartment fuse location table” on page 11-21.

WARNING

- Fusible links must not be replaced by any other device. Failing to fit the correct fusible link may result in fire in the vehicle, property destruction and serious or fatal injuries at any time.

Fuses

E01003003332

Fuse block location

E01011800035

To prevent damage to the electrical system due to short-circuiting or overloading, each individual circuit is provided with a fuse.

There are fuse blocks in the passenger compartment and in the engine compartment.

Passenger compartment (LHD vehicles)

The fuse blocks in the passenger compartment are located behind the fuse lid in front of the driver's seat at the position shown in the illustration.

Pull the fuse lid to remove it.

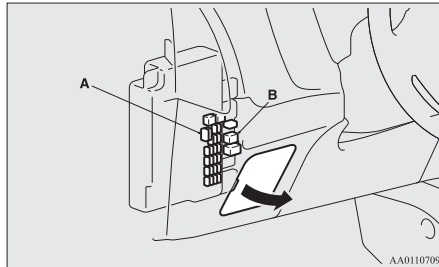

A- Main fuse block
B- Sub fuse block

Passenger compartment (RHD vehicles)

The fuse boxes in the passenger compartment are located behind the glove box at the position shown in the illustration.

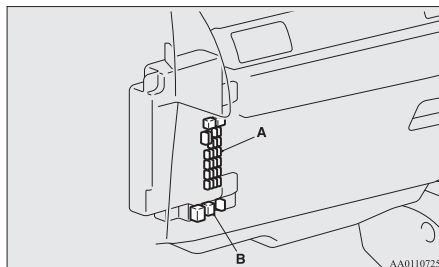

A- Main fuse block
B- Sub fuse block

Main fuse block

1. Open the glove box.
2. Uncouple the rod (A) on the right side of the glove box.

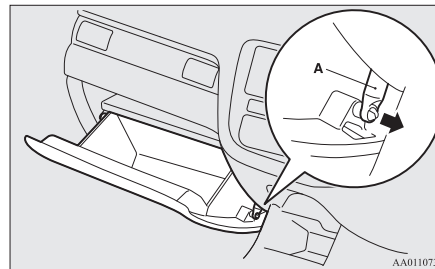

3. While pressing the side of the glove box, unhook the left and right hooks (B) and lower the glove box.

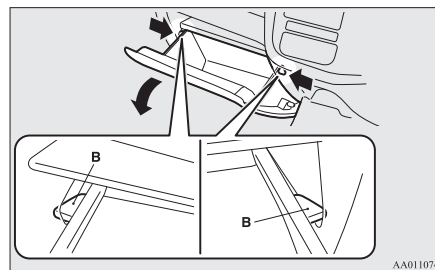

4. Remove the glove box fastener (C), and then remove the glove box.

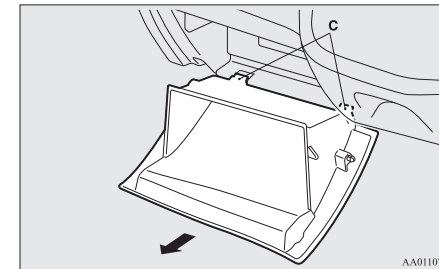

Sub fuse block

When changing the fuse of the sub fuse block, perform it with the hole of the bottom cover.

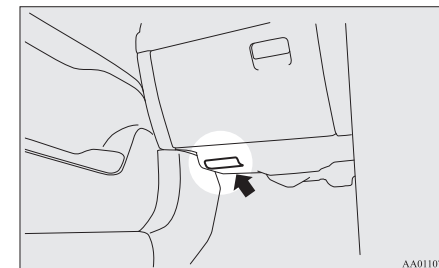

Fuses

Engine compartment

E01011900036

In the engine compartment, the fuse block is located as shown in the illustration. While pressing the tab (C), pull up the cover.

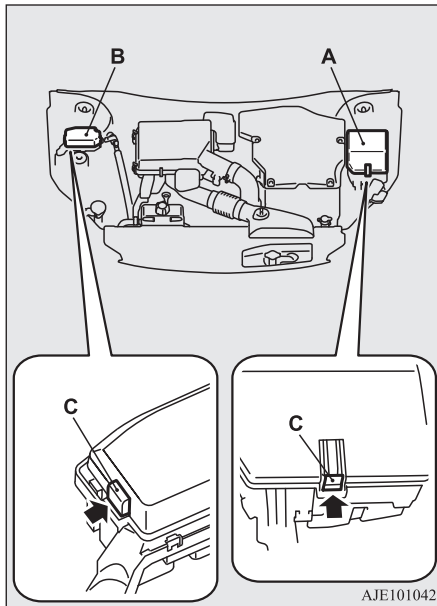

A- Main fuse block
B- Sub fuse block

Fuse load capacity

E01007701753

The fuse capacity and the names of electrical systems protected by the fuses are indicated on the inside of the fuse lid (LHD vehicles), the back side of the glove box (RHD vehicles) and inside of the fuse block cover (inside of the engine compartment).

NOTE

- Spare fuses are provided on the cover of main fuse block in the engine compartment. Always use a fuse of the same capacity for replacement.

Passenger compartment fuse location table

E01007902127

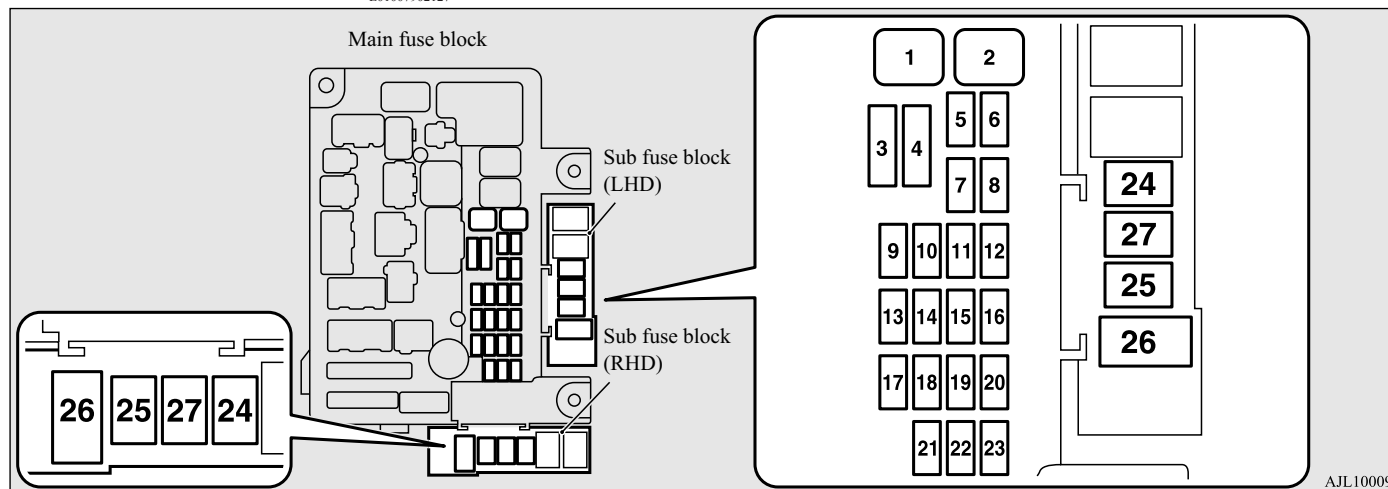

AJL100099

11

No.	Symbol	Electrical system	Capacities
1		Electric window control	30 A *1

*1: Fusible link

*2: Even if your vehicle is equipped with the rear fog lamp, the fuse of the rear fog lamp may not be installed on your vehicle.

No.	Symbol	Electrical system	Capacities
2		Rear window demister	30 A *1
3		Heater	30 A

*1: Fusible link



*2: Even if your vehicle is equipped with the rear fog lamp, the fuse of the rear fog lamp may not be installed on your vehicle.

No.	Symbol	Electrical system	Capacities
4		Windscreen wipers	30 A
5		Door locks	20 A

*1: Fusible link











*2: Even if your vehicle is equipped with the rear fog lamp, the fuse of the rear fog lamp may not be installed on your vehicle.

Fuses

No.	Symbol	Electrical system	Capacities
6		Rear fog lamp	10 A* ²
7		Accessory socket	15 A
8		Rear window wiper	15 A
9		Sunroof	20 A
10		Ignition switch	10 A
11		Option	10 A
12		Hazard warning flasher	15 A
13		4-wheel drive system	10 A
14	STOP	Stop lamps (Brake lamps)	15 A
15		Instruments	10 A
16		SRS airbag	7.5 A
17		Radio	15 A

*1: Fusible link

*2: Even if your vehicle is equipped with the rear fog lamp, the fuse of the rear fog lamp may not be installed on your vehicle.

No.	Symbol	Electrical system	Capacities
18		Control unit relay	7.5 A
19		Interior lamps (Room lamps)	15 A
20		Reversing lamps (Backup lamps)	7.5 A
21		Heated door mirror	7.5 A
22		Outside rear-view mirrors	10 A
23		Cigarette lighter/Accessory socket	15 A
24		Charge	7.5 A
		Heated steering wheel	15 A
25		Power seat (Driver seat)	30 A* ¹
26		Heated seat	30 A

*1: Fusible link

*2: Even if your vehicle is equipped with the rear fog lamp, the fuse of the rear fog lamp may not be installed on your vehicle.

No.	Symbol	Electrical system	Capacities
27		Power seat (Passenger seat)	30 A* ¹

*1: Fusible link

*2: Even if your vehicle is equipped with the rear fog lamp, the fuse of the rear fog lamp may not be installed on your vehicle.

- Some fuses may not be installed on your vehicle, depending on the vehicle model or specifications.
- The table above shows the main equipment corresponding to each fuse.

Engine compartment fuse location table

E01008002402

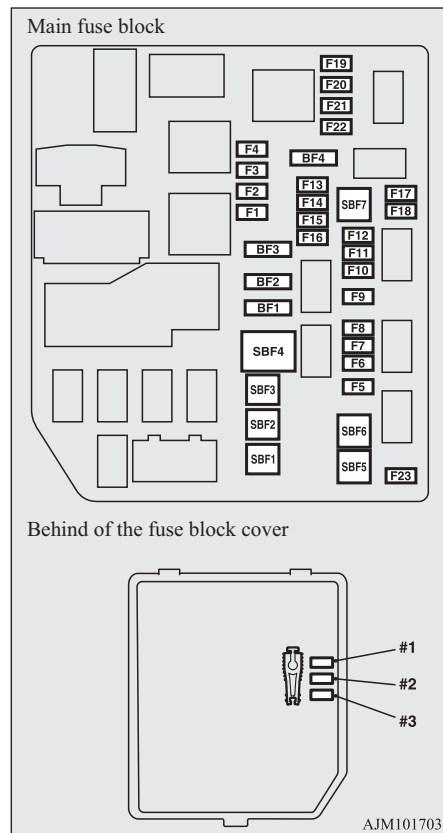

No.	Symbol	Electrical system	Capacity
SBF1		Air conditioning condenser fan motor	30 A*
SBF2	—	—	—
SBF3	—	—	—
SBF4		Radiator fan motor	40 A*
SBF5		Anti-lock brake system	40 A*
SBF6	—	—	—
SBF7		Anti-lock brake system	30 A*
BF1	PIGATE	Electric tailgate	30 A
BF2		Audio system amp	30 A
BF3	IOD	IOD	30 A
BF4	—	—	—
F1	—	—	—
F2		Wiper de-icer	15 A
F3		Electric parking brake	7.5 A
F4		Daytime running lamps	10 A

*: Fusible link

No.	Symbol	Electrical system	Capacity
F5		Front fog lamps	15 A
F6		Heated steering wheel	15 A
F7		Headlamp washer	20 A
F8		Security horn	20 A
F9		Horn	10 A
F10		ETV	15 A
F11		Charging lid lock	15 A
F12		Engine	7.5 A
F13		ENG/POWER	20 A
F14		Fuel pump	15 A
F15		Ignition coil	10 A
F16	—	—	—
F17		Headlamp high-beam (left)	10 A
F18		Headlamp high-beam (right)	10 A

*: Fusible link

Fuses

No.	Symbol	Electrical system		Capacity
F19		Headlamp low beam (left)	LED	20 A
F20		Headlamp low beam (right)	LED	20 A
F21		Headlamp low beam (left)	Halogen	10 A
F22		Headlamp low beam (right)	Halogen	10 A
F23	—	—	—	—
#1	—	Spare fuse		10 A
#2	—	Spare fuse		15 A
#3	—	Spare fuse		20 A

11

*: Fusible link

- Some fuses may not be installed on your vehicle, depending on the vehicle model or specifications.

- The table above shows the main equipment corresponding to each fuse.

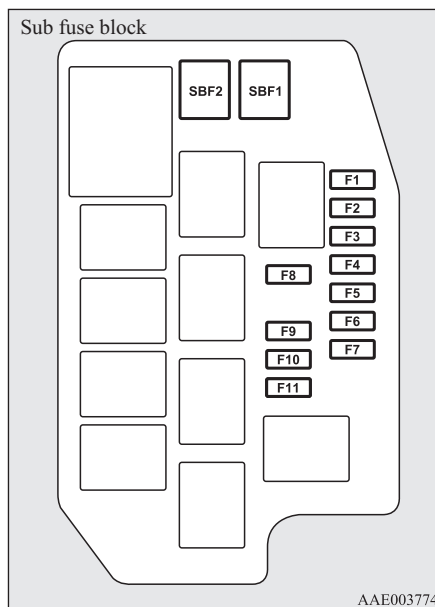



No.	Symbol	Electrical system	Capacity
SBF1		Electrical Parking Lock	30 A*

*: Fusible link

No.	Symbol	Electrical system	Capacity
SBF2		Vacuum pump (Regenerative brake)	30 A*
F1		Water pump (Electric motor)	20 A
F2		Battery management unit	7.5A
F3		Drive battery PTC heater	15A
F4		Fuel tank filler door	7.5 A
F5		Solenoid valve (Air conditioning)	7.5 A
F6		Water pump (Air conditioning)	7.5 A
F7		Electric motor unit control	10 A
F8		Heated windscreen	7.5 A
F9		Power feeder and charger connector (12V)	10 A
		Drive battery fun motor	15 A

*: Fusible link

No.	Symbol	Electrical system	Capacity
F10		Ignition control	15 A
F11		Ignition control	7.5 A

*: Fusible link

- Some fuses may not be installed on your vehicle, depending on the vehicle model or specifications.
- The table above shows the main equipment corresponding to each fuse.

The fuse block does not contain spare 7.5 A or 30 A fuses. If one of these fuses burns out, substitute with the following fuse.

7.5 A: 10 A spare fuse

30 A: 30 A audio system amp fuse

When using a substitute fuse, replace with a fuse of the correct capacity as soon as possible.

Identification of fuse

E01008101389

Capacity	Colour
7.5 A	Brown
10 A	Red
15 A	Blue

Capacity	Colour
20 A	Yellow
30 A	Green (fuse type) / Pink (fusible link type)
40 A	Green (fusible link type)

Fuse replacement

E01007801884

1. Before replacing a fuse, always turn off the electrical circuit concerned and put the operation mode of the power switch in OFF.
2. Remove the fuse puller (A) from the inside of the main fuse block cover in the engine compartment.

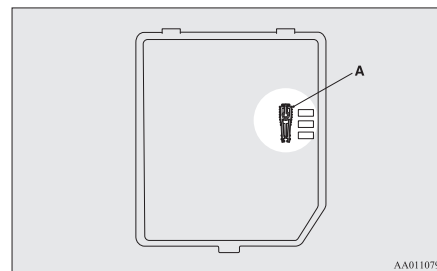

AA0110796

3. Referring to the fuse load capacity table, check the fuse pertaining to the problem.

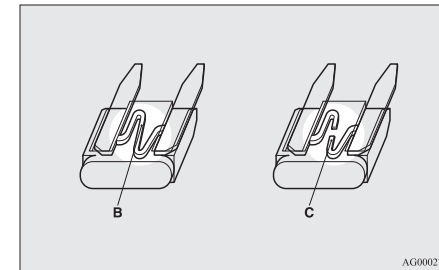

B- Fuse is OK
C- Blown fuse

NOTE

- If any system does not function but the fuse corresponding to that system is normal, there may be a fault in the system elsewhere. We recommend you to have your vehicle checked.

Replacement of lamp bulbs

4. Insert a new fuse of the same capacity by using the fuse puller into the same place in the fuse block.

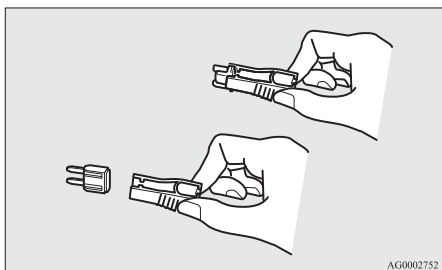

⚠ CAUTION

- If the newly inserted fuse blows again after a short time, we recommend you to have the electrical system checked to find the cause and rectify it.
- Never use a fuse with a larger capacity than specified or a substitute (such as a cable or foil). Doing so could cause the circuit wires to overheat and create a fire.

11

Replacement of lamp bulbs

E01003102004

Before replacing a bulb, ensure the lamp is off. Do not touch the glass part of the new bulb with your bare fingers; the skin oil left on the glass will evaporate when the bulb gets hot and the vapour will condense on the reflector and dim the surface.

⚠ CAUTION

- Do not install commercially available LED-type bulbs. Commercially available LED-type bulbs could adversely affect the operation of the vehicle, such as by preventing the lamps and other vehicle equipment from operating properly.
- Bulbs are extremely hot immediately after being turned off. When replacing a bulb, wait for it to cool sufficiently before touching it. You could otherwise be burnt.
- Handle halogen lamp bulbs with care. The gas inside a halogen lamp bulbs is highly pressurized, so dropping, knocking, or scratching a halogen lamp bulb can cause it to shatter.

⚠ CAUTION

- Never hold the halogen lamp bulb with a bare hand, dirty glove, etc. The oil from your hand could cause the bulb to break the next time the headlamps are operated. If the glass surface is dirty, it must be cleaned with alcohol, paint thinner, etc., and refit it after drying thoroughly.

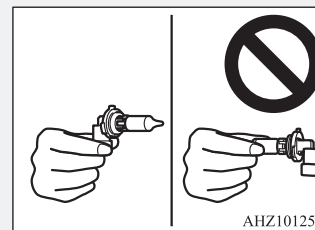

📖 NOTE

- If you are unsure of how to carry out the work as required, we recommend you to consult a specialist.
- Be careful not to scratch the vehicle body when removing a lamp or lens.

Replacement of lamp bulbs

NOTE

- When it rains or when the vehicle has been washed, the inside of the lens sometimes becomes foggy. This is the same phenomenon as when window glass mists up on a humid day, and does not indicate a functional problem. When the lamp is switched on, the heat will remove the fog. However, if water gathers inside the lamp, we recommend you to have the lamp checked.

Bulb location and capacity

E01003201747

CAUTION

- When replacing a bulb, be sure to use a new bulb of the same type, wattage and colour. If you install a different bulb, the bulb could malfunction or fail to come on and could lead to a vehicle fire.

Outside

E01003305498

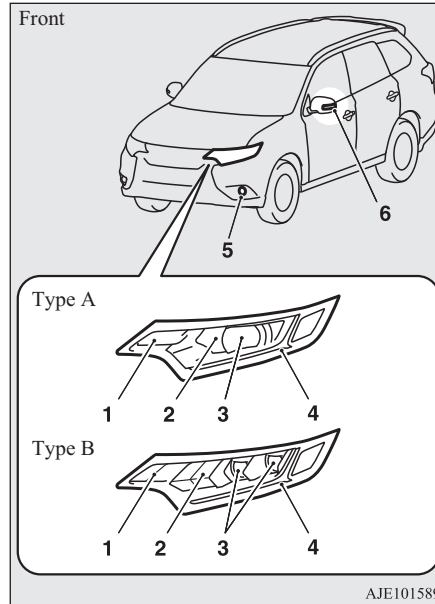

AJE101589

Type A: Halogen headlamps type

Type B: LED headlamps type

- 1- Front turn-signal lamps: 21 W (PY21W)
- 2- Headlamps, high-beam
Halogen: 60 W (HB3)
LED: -

- 3- Headlamps, low beam
Halogen: 55 W (H7)
LED: -
- 4- Position lamps: -
Daytime running lamps: -
- 5- Front fog lamps
Halogen: 19 W (H16)
LED: -
- 6- Side turn-signal lamps: -

Codes in parentheses indicate bulb types.

NOTE

- The following lamps use an LED instead of the bulb. If you need to repair or replace these lamps, contact a MITSUBISHI MOTORS Authorized Service Point.
 - Headlamps, high-beam (LED type)
 - Headlamps, low beam (LED type)
 - Position lamps
 - Daytime running lamps
 - Front fog lamps (LED type)
 - Side turn-signal lamps

Replacement of lamp bulbs

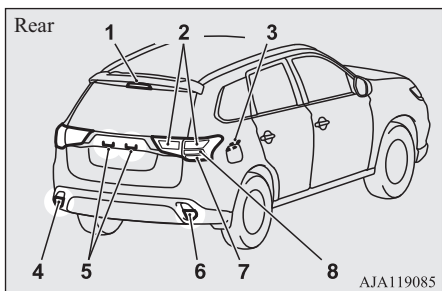

- 1- High-mounted stop lamp: –
 2- Tail lamps: –
 3- Charging port courtesy lamp: 5W (W5W)
 4- Rear fog lamp (LHD vehicles): 21 W (W21W)
 Reversing lamp (RHD vehicles): 16 W (W16W)
 5- Licence plate lamps: 5 W (W5W)
 6- Reversing lamp (LHD vehicles): 16 W (W16W)
 Rear fog lamp (RHD vehicles): 21 W (W21W)
 7- Rear turn-signal lamps: 21 W (WY21W)
 8- Stop lamps: –

Codes in parentheses indicate bulb types.

NOTE

- The following lamps use an LED instead of the bulb.
 If you need to repair or replace these lamps, contact a MITSUBISHI MOTORS Authorized Service Point.
 - High-mounted stop lamp
 - Tail lamps
 - Stop lamps

Inside

E01003403756

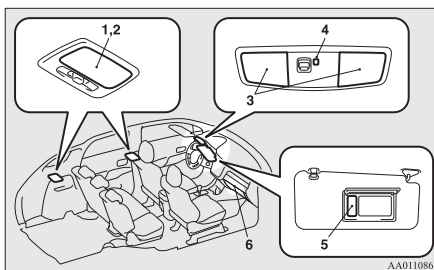

- 1- Luggage room lamp: 8 W
 2- Room lamp (rear): 8 W
 3- Map & room lamps (front): 8 W
 4- Downlight
 5- Vanity mirror lamps: 2 W
 6- Glove box lamp: 1.4 W

NOTE

- The following lamps use an LED instead of the bulb. If you need to repair or replace these lamps, contact a MITSUBISHI MOTORS Authorized Service Point.
 - Downlight
 - Front foot lamps

Headlamps (low beam, halogen bulb)

E01009301506

1. When replacing the bulb on the left side of the vehicle, remove the bolt (A) holding down the relay box and move the relay box.

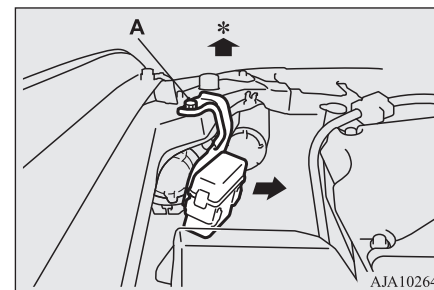

*: Front of the vehicle

Replacement of lamp bulbs

2. Turn the cap (B) anticlockwise to remove it.

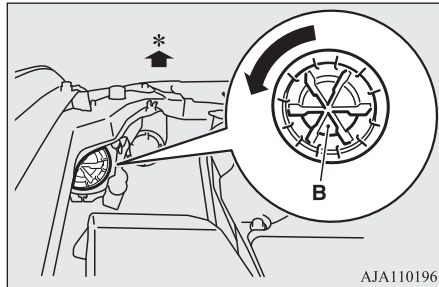

*: Front of the vehicle

3. Turn the socket (C) anticlockwise to remove it, and then pull the bulb out of the socket.

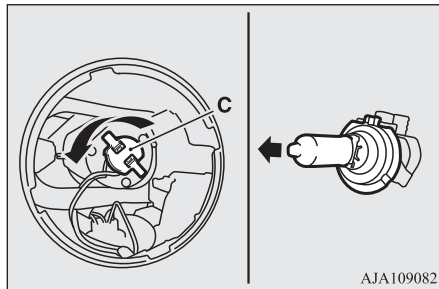

4. To install the bulb, perform the removal steps in reverse.

NOTE

- When installing the bulb, align the tab (D) with the notch (E) of the socket.

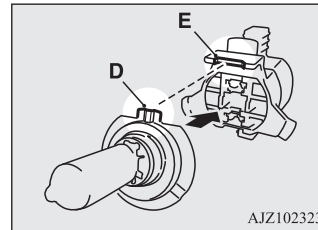

Headlamps (high-beam, halogen bulb)

E01009401376

1. When replacing the bulb on the right side of the vehicle, remove the clip (A) holding down the washer tank spout and then move it.

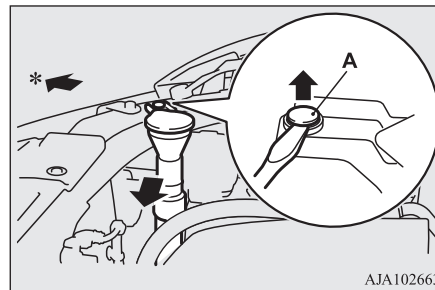

*: Front of the vehicle

2. Turn the cap (B) anticlockwise to remove it.

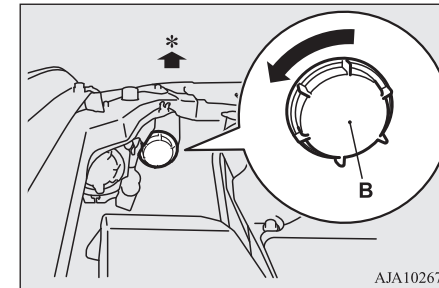

*: Front of the vehicle

Replacement of lamp bulbs

3. Turn the bulb (C) anticlockwise to remove it, and then while holding down the tab (D), pull out the bulb (E).

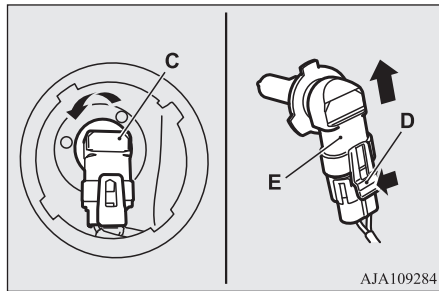

4. To install the bulb, perform the removal steps in reverse.

11

Front turn-signal lamps

E01003802320

⚠ CAUTION

- Make sure that the Plug-in Hybrid EV system have cooled down before replacing the bulb on the right side of the vehicle, otherwise you could be burnt by the radiator hose.

1. Remove the 12 clips (A, B), and then remove the cover (C).

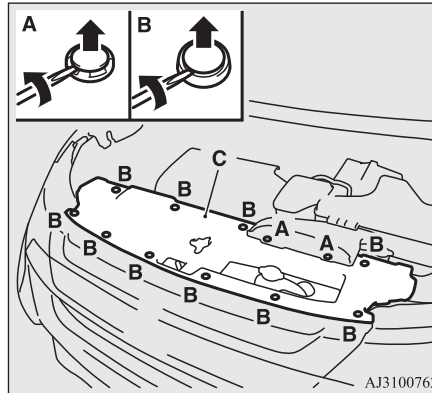

2. Turn the socket (D) anticlockwise to remove it, then remove the bulb from the socket by turning it anticlockwise while pressing in.

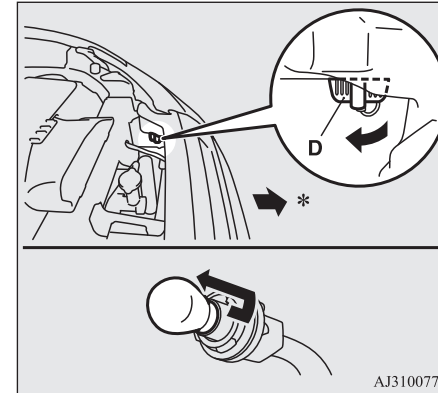

*: Front of the vehicle

3. To install the bulb, perform the removal steps in reverse.

Front fog lamps (Halogen bulb type)*

E01004003674

1. Insert a straight blade (or minus) screwdriver with a cloth over its tip at the

Replacement of lamp bulbs

points indicated by arrows and pry gently to remove the cover (A).

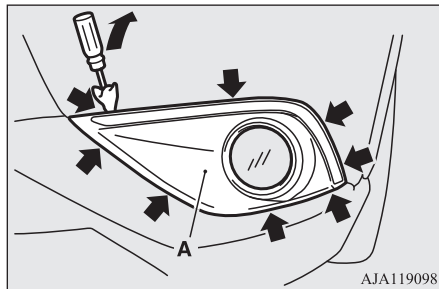

2. Remove the 3 screws (B) and remove the lamp unit.

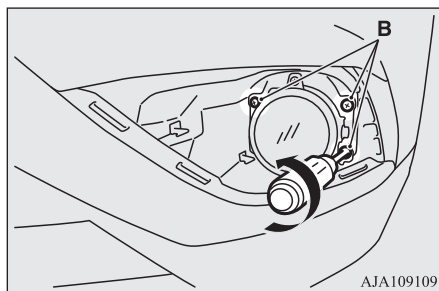

NOTE

- When unfastening the screws of the fog lamp, be careful not to mistakenly move the beam position adjustment screw (C).

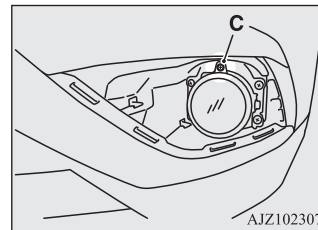

3. While holding down the tab (D), pull out the socket (E).

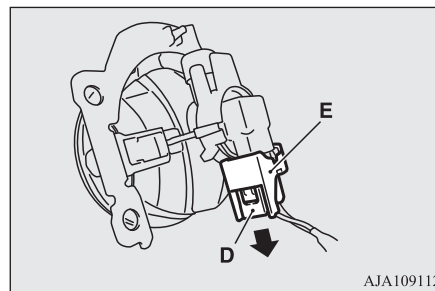

4. Turn the bulb (F) anticlockwise to remove it.

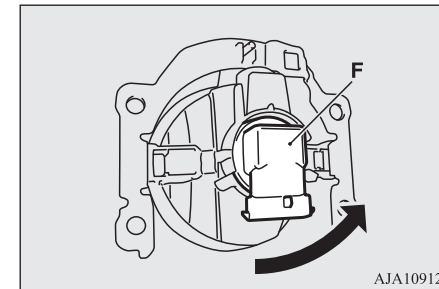

5. To install the bulb, perform the removal steps in reverse.

Replacement of lamp bulbs

Rear fog lamp (driver's side)/ Reversing lamp (Passenger's side)

E01004101655

1. Insert a straight blade (or minus) screwdriver with a cloth over its tip at the edge of the lamp unit, and then push the lamp unit upward to remove it.

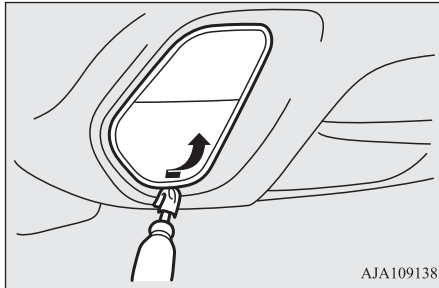

2. Turn the socket (A) anticlockwise to remove it, and then pull the bulb out of the socket.

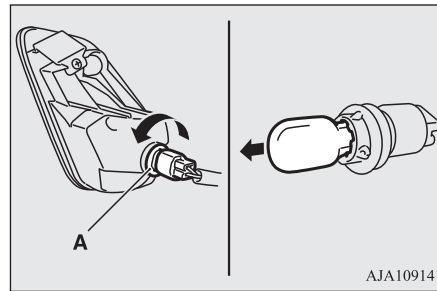

3. To install the bulb, perform the removal steps in reverse.

NOTE

- When installing the lamp unit, first insert the notch (B) into the hole on the body, and then push on the lamp unit to fit it into place.

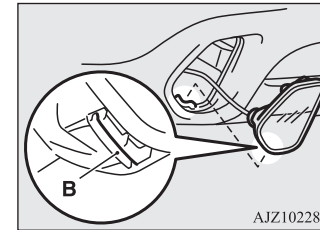

Rear combination lamps

E01004202767

1. Open the tailgate.

Replacement of lamp bulbs

2. Remove the screws (A), and then move the lamp unit towards the rear of the vehicle to unfix the notch (B) and pins (C) of the lamp unit.

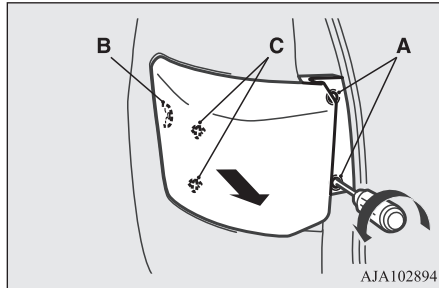

3. Turn the socket anticlockwise and remove it, and then pull the bulb out of the socket.

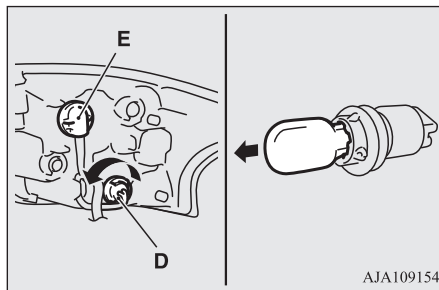

D- Rear turn-signal lamp

- E- Tail lamp and stop lamp (LED)-cannot be replaced

NOTE

- The tail lamp and stop lamp use an LED instead of the bulb. If you need to repair or replace these lamps, contact a MITSUBISHI MOTORS Authorized Service Point.

4. To install the bulb, perform the removal steps in reverse.

NOTE

- When installing the lamp unit, align the notch (F) and pin (G) on the lamp unit with the clip (H) and hole (I) in the body.

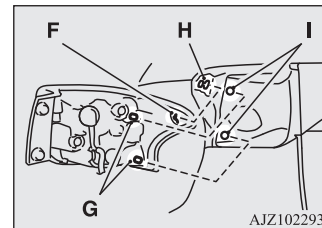

Licence plate lamps

E01004602325

1. Remove while pressing the lamp unit (A) to the left side of the vehicle.

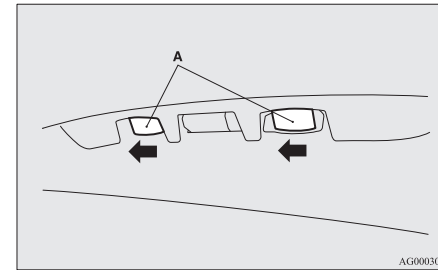

2. Insert a minus screwdriver with the end covered with a cloth or other object to press the hook (B) aside and remove the lens.

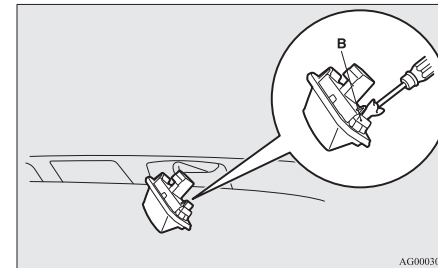

11

Replacement of lamp bulbs

3. Remove the bulb from the socket.

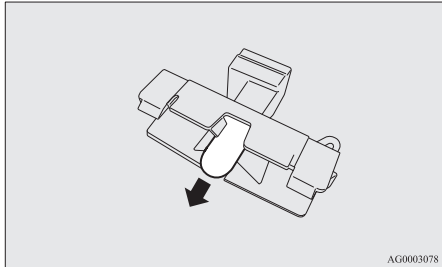

4. To install the bulb, perform the removal steps in reverse.

NOTE

- When installing the lamp unit, first insert the end of tab (C) and then align tab (D).

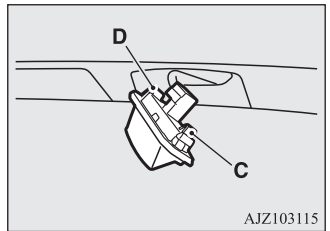

11

Specifications

Vehicle labeling.....	12-02
Vehicle dimensions.....	12-04
Vehicle performance.....	12-05
Vehicle weight.....	12-05
Engine specifications.....	12-06
Charging system specifications.....	12-07
Electric motor specifications.....	12-08
Low voltage electrical system.....	12-08
Tyres and wheels.....	12-09
Fuel consumption.....	12-09
Capacity.....	12-10

Vehicle labeling

Vehicle labeling

E01100105571

Vehicle identification number

The vehicle identification number is stamped on the bulkhead as shown in the illustration.

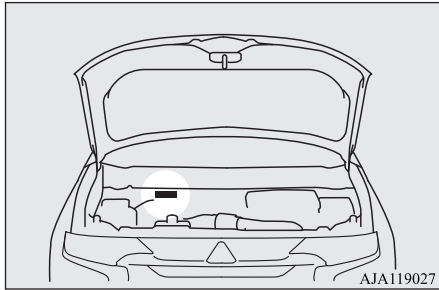

12

Vehicle information code plate

The vehicle information code plate is riveted as shown in the illustration.

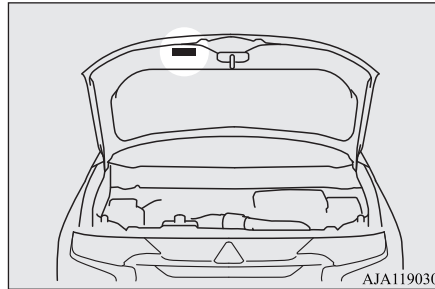

The plate shows the model code, engine model, transaxle model and body colour code, etc.

Please use this number when ordering replacement parts.

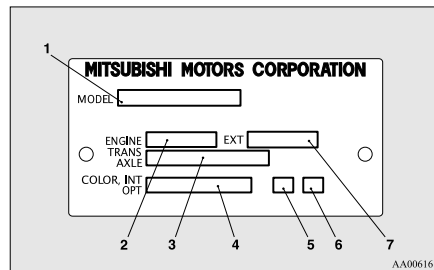

- 1- Model code
- 2- Engine model code
- 3- Transaxle model code
- 4- Body colour code
- 5- Interior code
- 6- Option code
- 7- Exterior code

Vehicle identification number plate (RHD vehicles only)

The vehicle identification number is stamped on the plate riveted to the left front corner of the instrument panel pad. It is visible from outside of the vehicle through the windscreen.

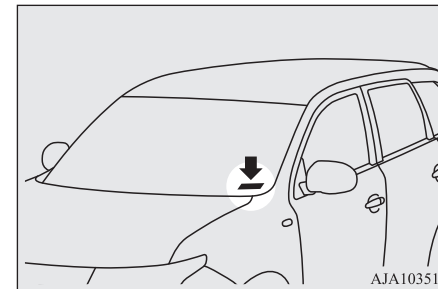

Engine model/number

The engine model and number are stamped on the engine cylinder block as shown in the illustration.

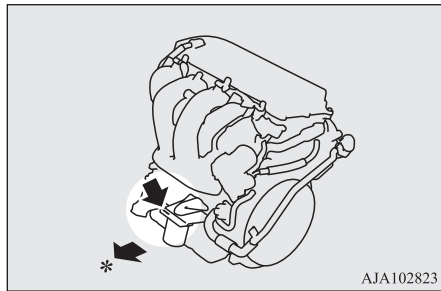

*: Front of the vehicle

Electric motor model/number

The electric motor model and number are stamped as shown in the illustration.

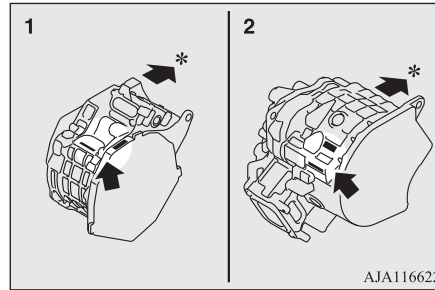

- 1- Front motor
- 2- Rear motor

*: Front of the vehicle

Vehicle dimensions

Vehicle dimensions

E01100205178

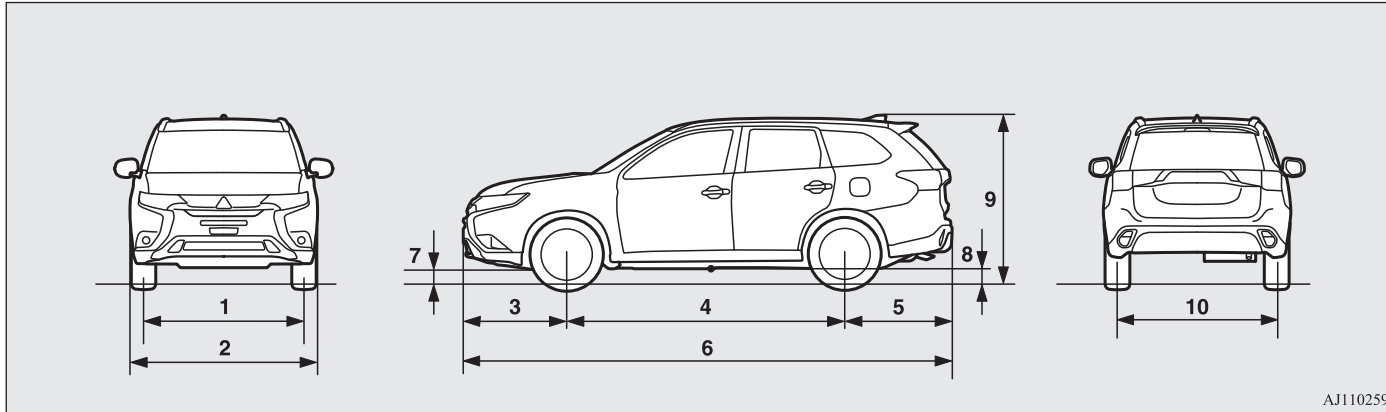

AJ1102599

12

1	Front track		1,540 mm
2	Overall width		1,800 mm
3	Front overhang		990 mm
4	Wheel base		2,670 mm
5	Rear overhang		1,035 mm
6	Overall length		4,695 mm
7	Ground clearance (unladen)	Without exhaust pipe protector	190 mm
8		With exhaust pipe protector	185 mm
9	Overall height (unladen)		1,710 mm
10	Rear track		1,540 mm

12-04 Specifications

OGGE19E1

Vehicle performance

Minimum turning radius	Body	5.76 m
	Wheel	5.3 m

Vehicle performance

E01100303553

Maximum speed	170 km/h
---------------	----------

Vehicle weight

E01100409309

Item		Except for S Edition		S Edition	
		LHD	RHD	LHD	RHD
Kerb weight	Without optional parts	1,880 kg		1,900 kg	
	With full optional parts	1,947 kg	1,945 kg	1,957 kg	1,955 kg
Maximum gross vehicle weight		2,390 kg			
Maximum axle weight	Front	1,200 kg			
	Rear	1,255 kg, 1,365 kg*			
Maximum towable weight	With brake	1,500 kg			
	Without brake	750 kg			
Maximum trailer-nose weight		75 kg			

12

*: In case of trailer towing

Engine specifications

Item	Except for S Edition		S Edition	
	LHD	RHD	LHD	RHD
Maximum roof load	80 kg			
Seating capacity	5 persons			

*: In case of trailer towing

NOTE

- Trailer specifications indicate the manufacturer's recommendation.

Engine specifications

E01100604856

Engine model	4B12
No. of cylinders	4 in line
Total displacement	2,360 cc
Bore	88.0 mm
Stroke	97.0 mm
Camshaft	Double overhead
Mixture preparation	Electronic injection
Maximum output (EEC net)	99 kW/4,500 rpm
Maximum torque (EEC net)	211 N•m/4,500 rpm

12

Charging system specifications

E01101901190

Normal charging system	Rated input voltage		AC 230V (single phase)
	Rated input frequency		50 Hz/60 Hz
	Maximum rated current		10 A ^{*1} , 8 A ^{*1}
	Maximum power consumption		3.6 kVA ^{*2}
	Applicable standards	Charging cable (with connector and control box)	EN61851-1 IEC61851-1 IEC62196-1
		On board charger	EN61851-21 IEC61851-21
	Leakage current sensitivity in cable control box		20 mA
	Charging mode		Based on IEC61851-1 Mode 2/Case B ^{*1} Mode 3/Case C ^{*2}
	IP degrees		IP44: When a charge connector is connected IP55: When charging lid is closed and vehicle is moving
Quick charging system	Applicable standards		IEC62196-1 CHAdeMO
	Maximum input current		60 A

*1: When using a genuine charging cable with control box

*2: When using a home or public charging device (EVSE: Electric Vehicles Supply Equipment)

Electric motor specifications

	IP degrees	IP44: When a charge connector is connected IP55: When the charging lid is closed and the vehicle is moving
--	------------	---

*1: When using a genuine charging cable with control box

*2: When using a home or public charging device (EVSE: Electric Vehicles Supply Equipment)

Electric motor specifications

E01100604869

Item	Front Motor	Rear Motor
Electric motor model	S61	Y61
Maximum output (ECE net)	60 kW	70 kW
Maximum torque	137 Nm	195 Nm
Maximum 30 minutes power	25 kW	

12

Low voltage electrical system

E01100804151

Voltage	12 V	
Auxiliary battery	Type (JIS)	S46B24L(S)
	Capacity (5HR)	36 Ah
Spark plug type	NGK	DIFR5E11

Tyres and wheels

E01100905104

Tyre		215/70R16 100H	225/55R18 98H
Wheel	Size	16x6 1/2J	18x7J
	Offset (Inset)	38 mm	

NOTE

- The tyres that can be installed on your vehicle are shown on the driver's door label, refer to "Tyre inflation pressures" on page 11-10. For details, contact a MITSUBISHI MOTORS Authorized Service Point.

Fuel consumption

E01102800056

Item	Combined (laden)		Electric consumption (Wh/km)	Electric range (km)
	CO ₂ (g/km)	Fuel consumption (L/100 km)		
NEDC*1	40	1.8	148	54*2
WLTC*3	46	2.0	169	45*4

*1: New European Driving Cycle

*2: All Electric Range

*3: Worldwide harmonized Light vehicles Test Cycle

*4: Equivalent All Electric Range

The values are based on UN R101. It varies depending on driving style, road and traffic conditions, ambient temperature, use of air conditioners and so forth.

Capacity

NOTE

- The results given do not express or imply any guarantee of all the values of the particular vehicle.
The vehicle itself has not been tested and there are inevitably differences between individual vehicles of the same model. In addition, this vehicle may incorporate particular modifications. Furthermore, the driver's style and road and traffic conditions, as well as the extent to which the vehicle has been driven and the standard of maintenance, will all affect its value.
- All mentioned values are referring to a new, driven in vehicle.

Capacity

E01101307558

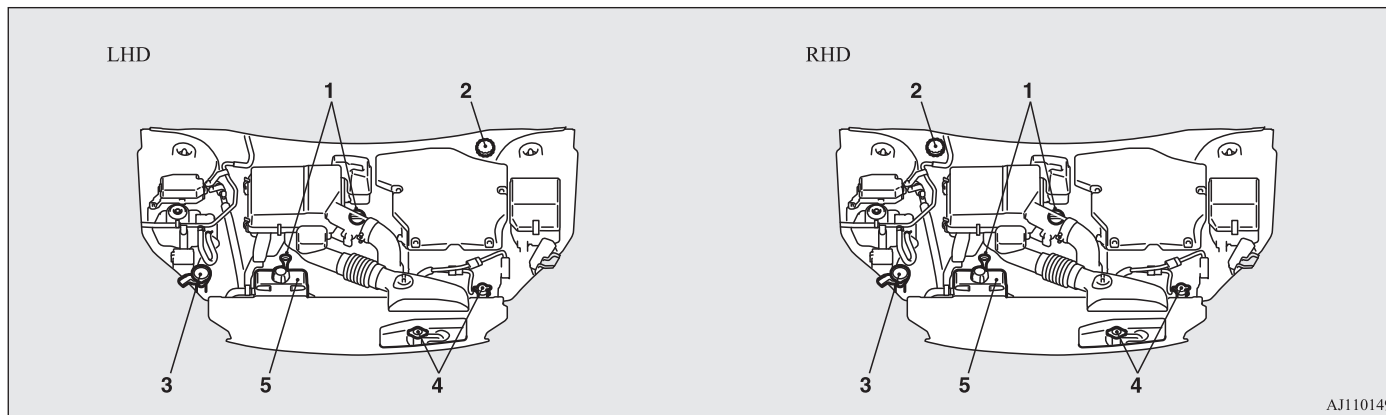

AJ1101491

12

Capacity

No.	Item		Quantity	Lubricants	
1	Engine oil		Oil pan	4.3 litres	Refer to page 11-05.
			Oil filter	0.3 litre	
2	Brake fluid		As required	Brake fluid DOT3 or DOT4	
3	Washer fluid		4.5 litres	—	
4	Engine coolant [includes 0.65 litre in the reserve tank]		Except for vehicles with electric heater	6.5 litres	MITSUBISHI MOTORS GENUINE SUPER LONG LIFE COOLANT PREMIUM or equivalent*
			Vehicles with electric heater	7.5 litres	
5	Rear Motor coolant [includes 1.07 litre in the reserve tank]		6.5 litres		
6	Front Motor fluid		2.2 litres	MITSUBISHI MOTORS GENUINE CVTF-J4	
7	Transaxle fluid		Front	3.46 litres	MITSUBISHI MOTORS GENUINE ATF SPIII
			Rear	0.85 litre	

*: Similar high quality ethylene glycol based non-silicate, non-amine, non-nitrate and non-borate coolant with long life hybrid organic acid technology

12

 **CAUTION**

- For the transaxle fluid, use only the MITSUBISHI MOTORS GENUINE ATF. Use of a different fluid could damage the transaxle.

Capacity

No.	Item	Quantity	Lubricants
8	Refrigerant (air conditioner)	520 - 560 g* ¹ , 495 - 535 g	HFC-134a* ¹ , HFO-1234yf

*¹: Vehicles for Ukraine

Cold	
Cautions and actions to deal with intense cold.....	2-10

2

220-240 V AC power supplies.....	8-76
----------------------------------	------

4

4-wheel drive operation.....	7-23
------------------------------	------

A

Accessory (Installation).....	2-17
Accessory socket.....	8-75
Acoustic Vehicle Alerting System (AVAS).....	2-06
Active stability control (ASC).....	7-43
Adaptive Cruise Control System (ACC).....	7-55
Air conditioner	
Automatic climate control air conditioner.....	8-06
Important operation tips for the air conditioner.....	8-14
Air purifier.....	8-15
Airbag.....	5-25
Caution for installing the child restraint in vehicles with front passenger's airbag.....	5-15,5-27
Anti-lock brake system (ABS).....	7-40
Ashtray.....	8-74
Assist grips.....	8-86
Audio	
CD player.....	8-15

LW/MW/FM radio.....	8-15
Troubleshooting.....	8-49
Automatic High-Beam (AHB).....	6-62
Auxiliary battery.....	11-09
Auxiliary battery charge warning lamp.....	6-57

B

Basic knowledge for charging.....	3-04
Battery	
Auxiliary battery charge warning lamp.....	6-57
Discharged battery (Emergency starting).....	9-02
Disposal information for used batteries.....	2-18
Specification.....	12-08
Blind Spot Warning (BSW).....	7-82
Bluetooth® 2.0 interface.....	8-51
Bonnet.....	11-04
Bottle holders.....	8-84
Brake assist system.....	7-39
Brake warning lamp.....	6-55
Brake	
Anti-lock brake.....	7-40
Brake auto hold.....	7-35
Braking.....	7-34
Fluid.....	11-08,12-10
Parking brake.....	7-03
Bulb capacity.....	11-25

C

Capacities.....	12-10
Card holder.....	8-74,8-82
Cargo area cover.....	8-85
Cargo loads.....	7-117

OGGE19E1

Alphabetical index

Catalytic converter.....	11-03
Cautions and actions to deal with intense cold.....	2-10
Cautions on handling of 4-wheel drive vehicles.....	7-25
Central door locks.....	4-16
Charging.....	3-02
Charging indicator.....	6-55
Charging system specifications.....	12-07
Charging troubleshooting guide.....	3-28
Check engine warning lamp.....	6-56
Child restraint.....	5-15
Caution for installing the child restraint in vehicles with front passenger's airbag.....	5-15,5-27
Child-protection rear doors.....	4-18
Cigarette lighter.....	8-75
Cleaning	
Exterior of your vehicle.....	10-03
Interior of your vehicle.....	10-02
Coat hook.....	8-86
Combination headlamps and dipper switch.....	6-59
Coolant (engine).....	11-06,12-10
Coolant (plug-in hybrid EV system).....	11-06
Cruise control.....	7-45
Cup holder.....	8-84

D

Daytime running lamps	
Bulb capacity.....	11-25
Demister (rear window).....	6-74
Digital clock	
Time Setting.....	8-47

Alphabetical index 13- 1

Alphabetical index

Dimensions.....	12-04
Dipper (High/Low beam change).....	6-61
Disposal information for used batteries.....	2-18
Doors	
Central door locks.....	4-16
Child-protection.....	4-18
Dead Lock System.....	4-17
Lock and unlock.....	4-14
Drive battery.....	2-05
Driving, alcohol and drugs.....	7-02

E

Economical driving.....	7-02
Electric motor model.....	12-02
Electric motor number.....	12-02
Electric motor specifications.....	12-08
Electric parking brake.....	7-03
Electric power steering system (EPS).....	7-42
Electric tailgate.....	4-20
Electric window control.....	4-34
Electrical Parking switch.....	7-18
Electronic immobilizer (Anti-theft starting system).....	4-03
Emergency starting.....	9-02
Emergency stop signal system.....	7-39
Engine specifications.....	12-06
Engine	
Coolant.....	11-06,12-10
Model.....	12-02
Number.....	12-02
Oil.....	11-05
Oil and oil filter.....	12-10

Overheating.....	9-04
Specifications.....	12-06
Used engine oils safety instructions and disposal information.....	2-18
EV charging cable.....	3-07
EV cruising range.....	2-05
EV switch.....	7-25
Exterior and interior lamp operation.....	11-16

F

Fluid capacities and lubricants.....	12-10
Fluid	
Brake fluid.....	11-08,12-10
Engine coolant.....	11-06,12-10
Front Motor fluid.....	12-10
Plug-in hybrid EV system coolant.....	11-06
Transaxle fluid.....	12-10
Washer fluid.....	11-08,12-10
For persons with electro-medical apparatus such as implantable cardiac pacemaker or implantable cardioverter-defibrillator.....	2-09
Forward Collision Mitigation System (FCM).....	7-67
Front fog lamps	
Bulb capacity.....	11-25
Indication lamp.....	6-55
Replacement.....	11-28
Switch.....	6-68
Front Motor fluid.....	12-10
Front room lamp.....	8-80
Bulb capacity.....	11-26
Front seats.....	5-03
Front turn-signal lamps	
Bulb capacity.....	11-25
Replacement.....	11-28

Fuel consumption.....	12-09
Fuel	
Filling the fuel tank.....	2-15
Fuel selection.....	2-14
Modification/alterations to the electrical or fuel systems.....	2-18
Tank capacity.....	2-16
Fuses.....	11-16
Fusible links.....	11-16

G

General maintenance.....	11-16
General vehicle data.....	12-04
Genuine parts.....	2-18
Glove box.....	8-82
Glove box lamp	
Bulb capacity.....	11-26

H

Hazard warning flasher switch.....	6-67
Hazard warning indication lamps.....	6-54
Head restraints.....	5-05
Headlamp levelling switch.....	6-66
Headlamp washer switch.....	6-73
Headlamps	
Bulb capacity.....	11-25
Headlamp flasher.....	6-61
Replacement.....	11-26
Switch.....	6-59
Heated mirror.....	7-10
Heated seats.....	5-04
Heated windscreen switch.....	6-75

Heating.....	8-15
High-mounted stop lamp.....	11-25
Hill start assist.....	7-37
Hinges and latches lubrication.....	11-16
Horn switch.....	6-77
How to use an electric device during charging.....	3-24

I

If the vehicle breaks down.....	9-02
In case of a collision.....	2-06
Indication lamps.....	6-54
Information screen display.....	6-58
Inside rear-view mirror.....	7-07
Inside tailgate release.....	4-27
Inspection and maintenance.....	2-08
Inspection and maintenance following rough road operation.....	7-24
Installation of accessories.....	2-17
Instruments.....	6-02
Intense cold	
Cautions and actions.....	2-10
Interior lamps.....	8-79

J

Jack.....	9-07
Storage.....	9-06
Jump starting (Emergency starting).....	9-02

K

Keyless entry system.....	4-03
---------------------------	------

Keyless operation system.....	4-06
Keys.....	4-02

L

Labeling.....	12-02
Lamp monitor buzzer.....	6-61
Lane Departure Warning (LDW).....	7-88
Leakage (Fuel, engine coolant, oil and exhaust gas).....	11-16
LED headlamp warning lamp.....	6-61
Licence plate lamps	
Bulb capacity.....	11-25
Replacement.....	11-31
Link System.....	8-51
Locking and unlocking the doors and tailgate.....	1-15
Low voltage electrical system.....	12-08
Lubricants.....	12-10
Luggage floor box.....	8-83
Luggage hooks.....	8-87
Luggage room lamp.....	8-81
Bulb capacity.....	11-26

M

Making a flat seat.....	5-08
Making a luggage area.....	5-06
Map lamps.....	8-80
Bulb capacity.....	11-26
Meter illumination control.....	6-03
Mirror	
Inside rear-view mirror.....	7-07
Outside rear-view mirror.....	7-09

OGGE19E1

Alphabetical index

MITSUBISHI Remote Control.....	3-20
Modification/alterations to the electrical or fuel systems.....	2-18
Multi Around Monitor.....	7-109
Multi information display.....	6-04

N

Normal charging (charging method with rated AC 220-240V outlet).....	3-10
--	------

O

Oil	
Engine oil.....	11-05,12-10
Operating sound under charging or remote climate control.....	2-06
Operation under adverse driving conditions.....	9-21
Outside rear-view mirrors.....	7-09
Overheating.....	9-04

P

Parking sensors.....	7-101
Parking.....	7-06
Parking brake.....	7-03
Plug-in Hybrid EV System.....	2-02
Coolant.....	11-06
Plug-in Hybrid EV System warning lamp.....	6-57
Position lamps	
Bulb capacity.....	11-25
Power switch.....	7-11
Precautions to observe when using wipers and washers.....	6-74

Alphabetical index

Pregnant women restraint.....	5-14
Puncture	
Tyre repair kit.....	9-07

Q

Quick charging (charging method with quick charger).....	3-17
---	------

R

Ready indicator.....	6-55
Rear combination lamps	
Bulb capacity.....	11-25
Replacement.....	11-30
Rear Cross Traffic Alert.....	7-86
Rear fog lamp	
Bulb capacity.....	11-25
Replacement.....	11-30
Switch.....	6-69
Rear Motor coolant.....	12-10
Rear room lamp.....	8-80
Bulb capacity.....	11-26
Rear turn-signal lamps	
Bulb capacity.....	11-25
Replacement.....	11-28
Rear window demister switch.....	6-74
Rear-view camera.....	7-105
Rear-view mirror	
Inside.....	7-07
Outside.....	7-09
Regenerative braking level selector (paddle type).....	7-19
Replacement of lamp bulbs.....	11-24

Reversing lamp	
Bulb capacity.....	11-25
Replacement.....	11-30
Reversing sensor system.....	7-97
Roof carrier precaution.....	7-118
Room lamp.....	8-79

S

S-AWC (Super-All Wheel Control).....	7-20
Safe driving techniques.....	7-02
Safety and disposal information for used engine oil.....	2-18
Seat belt	
Adjustable seat belt anchor.....	5-12
Child restraint.....	5-15
Force limiter.....	5-15
Inspection.....	5-25
Pregnant women restraint.....	5-14
Pretensioner.....	5-15
Seat belt reminder.....	5-11
Seat belts.....	5-09
Seat	
Adjustment.....	5-02
Front seats.....	5-03
Head restraints.....	5-05
Heated seats.....	5-04
Making a flat seat.....	5-08
Making a luggage area.....	5-06
Rear seat.....	5-05
Security alarm system.....	4-27
Select position indicator.....	7-17
Selector lever (Joystick type).....	7-15
Service precaution.....	11-02
Side turn-signal lamps	

Bulb capacity.....	11-25
Snow traction device (tyre chains).....	11-13
Snow tyres.....	11-13
Spark plug.....	12-08
Specifications.....	12-02
Speed Limiter.....	7-50
SPORT mode switch.....	7-31
Starting and stopping the Plug-in Hy- brid EV System.....	7-13
Steering	
Steering wheel height adjustment.....	7-07
Stop lamps	
Bulb capacity.....	11-25
Storage spaces.....	8-82
Sun visors.....	8-73
Sunglasses holder.....	8-83
Sunroof.....	4-36
Super-All Wheel Control (S-AWC).....	7-20
Supplemental restraint system.....	5-25
Caution for installing the child re- straint in vehicles with front pas- senger's airbag.....	5-15,5-27
Servicing.....	5-35
System check screen.....	6-15

T

Tail lamps	
Bulb capacity.....	11-25
Tailgate.....	4-19
Tank capacity.....	2-16
Time Setting.....	8-47
Tools.....	9-07

Storage..... 9-06
Towing.....9-17
Trailer towing..... 7-118
Transaxle fluid 12-10
Turn-signal indication lamps.....6-54
Turn/Lane-change signals..... 6-67
Tyre pressure monitoring system (TPMS)..... 7-92
Tyre repair kit.....9-07
Tyres..... 11-10
 How to change a tyre..... 9-13
 Inflation pressures..... 11-10
 Rotation..... 11-12
 Size (tyre and wheel)..... 12-09
 Snow traction device (tyre chains)..... 11-13
 Snow tyres..... 11-13
 Tread wear indicators..... 11-11
 Tyre repair kit.....9-07

U

Ultrasonic misacceleration Mitigation
System (UMS)..... 7-77
USB input terminal.....8-71
 How to connect a USB memory..... 8-72
 How to connect an iPod..... 8-72

V

Vanity mirror lamp
 Bulb capacity.....11-26
Vehicle care precautions..... 10-02
Vehicle dimensions..... 12-04
Vehicle identification number..... 12-02
Vehicle identification number plate.....12-02

Vehicle information code plate..... 12-02
Vehicle labeling..... 12-02
Vehicle performance..... 12-05
Vehicle weight..... 12-05
Ventilators.....8-02

W

Warning lamps.....6-55
Washer
 Fluid..... 11-08,12-10
 Switch..... 6-73
Washing..... 10-03
Waxing.....10-05
Weight..... 12-05
Wheel
 Specification..... 12-09
Wiper de-icer switch..... 6-74
Wiper
 Rear window..... 6-72
 Windscreen.....6-69
 Wiper blades..... 11-14

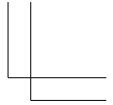
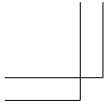

Handwriting practice area consisting of 12 horizontal dashed lines.

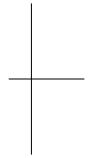
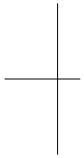

OGGE19E1

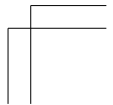
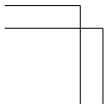

A) Generic information:

Manufacturer Postal Address

OMRON Automotive Electronics Co. Ltd.
6368 Nenjozaka, Okusa, Komaki, Aichi 485-0802 JAPAN

B) Language Text:

01_RED_BG_Bulgarian	
ОПРОСТЕНА ЕС ДЕКЛАРАЦИЯ ЗА СЪОТВЕТСТВИЕ	С настоящия документ OMRON Automotive Electronics Co. Ltd., декларира, че J166E, GHR-M001, G8D-644M-KEY-E, GGM-M002 съответстват с Директива 2014/53/ЕС. За подробности посетете следния адрес: http://www.mitsubishi-motors.com/en/red-doc/
	Честотни ленти, на които работи радиооборудването: J166E, G8D-644M-KEY-E : 433.92MHz GHR-M001, GGM-M002 : 125kHz
	Максималната радиочестотна енергия, предавана по честотната лента (честотните ленти) на която/които работи радиооборудването: J166E, G8D-644M-KEY-E : 1µW GHR-M001 : 82dBµV/m [@3m] GGM-M002 : 62dBµV/m [@10m]
	ВНИМАНИЕ Риск от експлозия, ако батерията е сменена с неправилния вид. Изхвърлете използваните батерии според инструкциите.
02_RED_ES_Spanish	
DECLARACIÓN UE DE CONFORMIDAD SIMPLIFICADA	Por la presente, OMRON Automotive Electronics Co. Ltd., declara que J166E, GHR-M001, G8D-644M-KEY-E, GGM-M002 cumple con la Directiva 2014/53/UE. Para más información, acceda a la siguiente URL: http://www.mitsubishi-motors.com/en/red-doc/
	Banda(s) de frecuencia en que opera el equipo radioeléctrico: J166E, G8D-644M-KEY-E : 433.92MHz GHR-M001, GGM-M002 : 125kHz
	Máxima potencia radioeléctrica transmitida en la(s) banda(s) de frecuencia en las que opera el equipo radioeléctrico: J166E, G8D-644M-KEY-E : 1µW GHR-M001 : 82dBµV/m [@3m]

	GGM-M002 : 62dBµV/m [@10m]
	ADVERTENCIA Existe riesgo de explosión si sustituye la batería por un modelo inadecuado. Desahágase de las baterías usadas siguiendo las instrucciones.
03_RED_CS_Czech	
ZJEDNODUŠENÉ EU PROHLÁŠENÍ O SHODĚ	Společnost OMRON Automotive Electronics Co. Ltd. tímto prohlašuje, že J166E, GHR-M001, G8D-644M-KEY-E, GGM-M002 dodržuje Nařízení 2014/53/EU. Podrobné informace naleznete na následující URL: http://www.mitsubishi-motors.com/en/red-doc/ Frekvenční pásmo (pásmo), ve kterých rádiové zařízení funguje: J166E, G8D-644M-KEY-E : 433.92MHz GHR-M001, GGM-M002 : 125kHz Maximální radiofrekvenční energie, přenášené v rámci frekvenčních pásem, ve kterých rádiové zařízení funguje: J166E, G8D-644M-KEY-E : 1µW GHR-M001 : 82dBµV/m [@3m] GGM-M002 : 62dBµV/m [@10m]
	UPOZORNĚNÍ Nebezpečí výbuchu, pokud je baterie nahrazena nesprávným typem. Použité baterie zlikvidujte v souladu s pokyny.
04_RED_DA_Danish	
FORENKLET EU-OVERENSSTTE MMEELSEERKLÆ RING	OMRON Automotive Electronics Co. Ltd. erklærer herved, at J166E, GHR-M001, G8D-644M-KEY-E, GGM-M002 er i overensstemmelse med Direktiv 2014/53/EU. For detaljer, bedes du adgang til følgende webadresse: http://www.mitsubishi-motors.com/en/red-doc/ Frekvensbåndet (er), hvor radiostyret driver: J166E, G8D-644M-KEY-E : 433.92MHz GHR-M001, GGM-M002 : 125kHz Maksimal radiofrekvens effekt transmitteret i frekvensbåndet (er), hvor radiostyret driver: J166E, G8D-644M-KEY-E : 1µW GHR-M001 : 82dBµV/m [@3m] GGM-M002 : 62dBµV/m [@10m]]
	FORSIGTIGHED Risiko for eksplosion hvis batteriet udskiftes med et af forkert type. Bortskaf brugte batterier i henhold til instruktionerne.

05_RED_DE_German	
VEREINFACHTE EU-KONFORMITÄT SERKLÄRUNG	Hiermit erklärt OMRON Automotive Electronics Co. Ltd., dass J166E, GHR-M001, G8D-644M-KEY-E, GGM-M002 in Übereinstimmung mit der Richtlinie 2014/53/EU steht. Für Einzelheiten greifen Sie auf folgende URL zu: http://www.mitsubishi-motors.com/en/red-doc/
	Frequenzband/Frequenzbänder, in dem das Funkgerät betrieben wird: J166E, G8D-644M-KEY-E : 433.92MHz GHR-M001, GGM-M002 : 125kHz
	Maximal übertragene Hochfrequenzleistung im Frequenzband/Frequenzbänder, in dem das Funkgerät betrieben wird: J166E, G8D-644M-KEY-E : 1µW GHR-M001 : 82dBµV/m [@3m] GGM-M002 : 62dBµV/m [@10m]
	VORSICHT Explosionsgefahr, wenn die Batterie durch einen falschen Typ ersetzt wird. Entsorgen Sie die gebrauchten Batterien gemäß den Anweisungen.
06_RED_ET_Estonian	
LIHTSUSTATUD ELI VASTAVUSDEKLARATSIOON	Käesolevaga teatab OMRON Automotive Electronics Co. Ltd., et J166E, GHR-M001, G8D-644M-KEY-E, GGM-M002 on kooskõlas Direktiiviga 2014/53/EL. Üksikasjade nägemiseks külastage võrguadressi: http://www.mitsubishi-motors.com/en/red-doc/
	Sagedusala(d), milles raadioseade töötab: J166E, G8D-644M-KEY-E : 433.92MHz GHR-M001, GGM-M002 : 125kHz
	Maksimaalne saatetõhusus/võimsustihedus sagedusala(de)s, milles raadioseade töötab: J166E, G8D-644M-KEY-E : 1µW GHR-M001 : 82dBµV/m [@3m] GGM-M002 : 62dBµV/m [@10m]
	HOIATUS Põhivõimsust, kui patarei asendatakse valet tüüpi patareiga. Kõrvaldage kasutatud patareid vastavalt juhendile.
07_RED_EL_Greek	
ΑΠΛΟΥΣΤΕΥΜΕΝΗ ΔΗΛΩΣΗ ΣΥΜΜΟΡΦΩΣΗΣ	Με το παρόν, η OMRON Automotive Electronics Co. Ltd., δηλώνει ότι τα J166E, GHR-M001, G8D-644M-KEY-E, GGM-M002 συμμορφώνονται με την Οδηγία 2014/53/ΕΕ. Για λεπτομέρειες, επισκεφτείτε την εξής ιστοσελίδα:

14- 4 Declaration of Conformity

OGGE19E1

EE	<p>http://www.mitsubishi-motors.com/en/red-doc/</p> <p>Ζώνες συχνοτήτων στις οποίες λειτουργεί ο ραδιοεξοπλισμός: J166E, G8D-644M-KEY-E : 433.92MHz GHR-M001, GGM-M002 : 125kHz</p> <p>Μέγιστη εκπεμπόμενη ισχύς ραδιοσυχνοτήτων στις ζώνες συχνοτήτων στις οποίες λειτουργεί ο ραδιοεξοπλισμός: J166E, G8D-644M-KEY-E : 1μW GHR-M001 : 82dBμV/m [@3m] GGM-M002 : 62dBμV/m [@10m]</p> <p>ΠΡΟΣΟΧΗ Κίνδυνος έκρηξης σε περίπτωση αντικατάστασης της μπαταρίας με άλλη ασφαλέμενου τύπου. Απορρίψτε τις άδεις μπαταρίες σύμφωνα με τις οδηγίες.</p>
08_RED_EN_English	
SIMPLIFIED EU DECLARATION OF CONFORMITY	<p>Hereby, OMRON Automotive Electronics Co. Ltd., declares that J166E, GHR-M001, G8D-644M-KEY-E, GGM-M002 are in compliance with Directive 2014/53/EU. For details, please access the following URL: http://www.mitsubishi-motors.com/en/red-doc/</p> <p>Frequency band(s) in which the radio equipment operates: J166E, G8D-644M-KEY-E : 433.92MHz GHR-M001, GGM-M002 : 125kHz</p> <p>Maximum radio-frequency power transmitted in the frequency band(s) in which the radio equipment operates: J166E, G8D-644M-KEY-E : 1μW GHR-M001 : 82dBμV/m [@3m] GGM-M002 : 62dBμV/m [@10m]</p> <p>CAUTION Risk of explosion if battery is replaced by an incorrect type. Dispose of used batteries according to the instructions.</p>
09_RED_FR_French	
DECLARATION UE DE CONFORMITE SIMPLIFIEE	<p>Par le présent document OMRON Automotive Electronics Co. Ltd., déclare que J166E, GHR-M001, G8D-644M-KEY-E, GGM-M002 sont conformes à la Directive 2014/53/UE. Pour plus d'informations visitez la page suivante: http://www.mitsubishi-motors.com/en/red-doc/</p> <p>Bandes de fréquence dans lesquelles fonctionne l'appareil à radiofréquence: J166E, G8D-644M-KEY-E : 433.92MHz</p>

	GHR-M001, GGM-M002 : 125kHz
	Puissance radiofréquence maximale transmise dans la (les) bande(s) de fréquence dans laquelle/lesquelles l'appareil à radiofréquence fonctionne: J166E, G8D-644M-KEY-E : 1µW GHR-M001 : 82dBµV/m [@3m] GGM-M002 : 62dBµV/m [@10m]
	ATTENTION Risque d'explosion si la pile est remplacée par un type incorrect de pile. Jetez les piles usagées conformément aux instructions.
10_RED_IS_Icelandic	
EINFÖLDUÐ ESB-SAMRÆMISY FIRLÝSING	Hér, OMRON Automotive Electronics Co. Ltd., segir að J166E, GHR-M001, G8D-644M-KEY-E, GGM-M002 þeir eru í samræmi við Úrskurði 2014/53/ESB. Fyrir frekari upplýsingar, vinsamlegast aðgang að eftirfarandi URL: http://www.mitsubishi-motors.com/en/red-doc/
	Tíðnisviði (s) sem þröðlausan búnað undirrita burt: J166E, G8D-644M-KEY-E : 433.92MHz GHR-M001, GGM-M002 : 125kHz
	Mámarks útláttar-tíðni máttur miðlað á tíðnisviðinu (s) sem þröðlausan búnað undirrita burt: J166E, G8D-644M-KEY-E : 1µW GHR-M001 : 82dBµV/m [@3m] GGM-M002 : 62dBµV/m [@10m]
	VARÚÐ Það er hætt á sprengingu ef rafhláðan er skipt með rangri tegund. Notuðu rafhláður eru fargað samkvæmt leiðbeiningum.
11_RED_HR_Croatian	
POJEDNOSTAVLJ ENA EU IZJAVA O SUKLADNOSTI	Ovim putem tvrtka OMRON Automotive Electronics Co. Ltd. objavljuje da je J166E, GHR-M001, G8D-644M-KEY-E, GGM-M002 sukladna s Direktivom 2014/53/EU. Za pojedinosti posjetite sljedeći URL: http://www.mitsubishi-motors.com/en/red-doc/
	Frekvencijski pojas (pojaševi) u kojima radi radio oprema: J166E, G8D-644M-KEY-E : 433.92MHz GHR-M001, GGM-M002 : 125kHz
	Maksimalna snaga radio frekvencije prenesena u frekvencijske pojaseve u kojima radi radio oprema: J166E, G8D-644M-KEY-E : 1µW GHR-M001 : 82dBµV/m [@3m]

	GGM-M002 : 62dB μ V/m [@10m]
	OPREZ Opasnost oc eksplozije baterije ako se zamijeni s neodgovarajućim tipom. Odbacite baterije u skladu s uputama.
12_RED_IT_italian	
DICHIARAZIONE DI CONFORMITÀ UE SEMPLIFICATA	Con la presente, OMRON Automotive Electronics Co. Ltd., dichiara che J166E, GHR-M001, G8D-644M-KEY-E, GGM-M002 sono conformi alla Direttiva 2014/53/UE. Per ulteriori dettagli, accedere al seguente URL: http://www.mitsubishi-motors.com/en/red-doc/ Banda/e di frequenza su cui operano le apparecchiature radio: J166E, G8D-644M-KEY-E : 433.92MHz GHR-M001, GGM-M002 : 125kHz Massima alimentazione a radiofrequenza trasmessa sulla/e banda/e di frequenza su cui operano le apparecchiature radio: J166E, G8D-644M-KEY-E : 11 μ W GHR-M001 : 82dB μ V/m [@3m] GGM-M002 : 62dB μ V/m [@10m]
	ATTENZIONE L'utilizzo di una batteria di diverso tipo può provocare esplosioni. Smaltire le batterie usate in conformità con le istruzioni.
13_RED_LV_Latvian	
VIENKĀRŠOTA ES ATBILSTĪBAS DEKLARĀCIJA	Ar šo uzņēmums OMRON Automotive Electronics Co. Ltd. apstiprina, ka J166E, GHR-M001, G8D-644M-KEY-E, GGM-M002 atbilst Direktīvas 2014/53/ES prasībām. Detalizētu informāciju, lūdzu, skatiet šajā vietnē URL: http://www.mitsubishi-motors.com/en/red-doc/ Frekvences ,oslā(-s), kurās darbojas radio aprīkojums: J166E, G8D-644M-KEY-E : 433.92MHz GHR-M001, GGM-M002 : 125kHz Radio aprīkējuma darbības frekvenču joslā(-s) radītā maksimālā radiofrekvences jauda: J166E, G8D-644M-KEY-E : 11 μ W GHR-M001 : 82dB μ V/m [@3m] GGM-M002 : 62dB μ V/m [@10m]
	BRĪDINĀJUMS Ja akumulators tiek aizvietots ar nepareiza veida akumulatoru, pastāvs sprādzienbīstamības risks.

	Izlietotos akumulatorus utilizējiet atbilstoši instrukcijām.
14_RED_LT_Lithuanian	
SUPAPRASTINTA	Šiuo dokumentu OMRON Automotive Electronics Co. Ltd. pareiškia, kad J166E,
ES ATITIKTIES	GHR-M001, G8D-644M-KEY-E, GGM-M002 atitinka Direktyvą 2014/53/ES.
DEKLARACIJA	Norėdami išsamesnės informacijos, apsilankykite šiuo URL adresu: http://www.mitsubishi-motors.com/en/red-doc/
	Dažnio juosta (-os), kurioje veikia radijo įranga: J166E, G8D-644M-KEY-E : 433.92MHz GHR-M001, GGM-M002 : 125kHz
	Didžiausia radijo dažnio galia, perduodama dažnio juosta (-os), kurioje veikia radijo įranga: J166E, G8D-644M-KEY-E : 11µW GHR-M001 : 82dBµV/m [@3m] GGM-M002 : 62dBµV/m [@10m]
	ĮSPĖJIMAS Pakeitęs bateriją netinkamo tipo baterija, kyla sprogimo pavojus. Panaudotas baterijas šalinkite pagal instrukcijas.
15_RED_HU_Hungarian	
EGYSZERŪSÍTET	Alulírott, OMRON Automotive Electronics Co. Ltd., kijelenti, hogy J166E,
T	GHR-M001, G8D-644M-KEY-E, GGM-M002 megfelel a 2014/53/EU irányelvnek. A
EU-MEGFELELŐS	részletekért nyissa meg a következő URL hivatkozást:
ÉGI	http://www.mitsubishi-motors.com/en/red-doc/
NYILATKOZAT	
	A rádióberendezés működéséhez szükséges frekvenciasáv(ok): J166E, G8D-644M-KEY-E : 433.92MHz GHR-M001, GGM-M002 : 125kHz
	A rádióberendezés működéséhez szükséges frekvenciasáv(ok) maximális rádiófrekvenciás teljesítménye: J166E, G8D-644M-KEY-E : 11µW GHR-M001 : 82dBµV/m [@3m] GGM-M002 : 62dBµV/m [@10m]
	VIGYÁZAT A nem megfelelő típusú csereelem robbanveszélyt okozhat. Az utasítások betartásával ártalmatlanítsa a használt elemeket.
16_RED_MT_Maltese	
DIKJARAZZJONI	OMRON Automotive Electronics Co. Ltd., tiddikjara li J166E, GHR-M001,

SSIMPLIFIKATA TA' KONFORMITÀ TAL-UE	G8D-644M-KEY-E, GGM-M002 huma f'konformità mad-Direttiva 2014/53/UE. Għal dettalji, jekk iogħbok accessa l-URL li ġejja: http://www.mitsubishi-motors.com/en/red-doc/ Medda(meded) ta' frekwenza li fiha jopera t-tagħmir tar-radju: J166E, G8D-644M-KEY-E : 433.92MHz GHR-M001, GGM-M002 : 125kHz Qawwa massima tal-medda ta' frekwenza tar-radju trażmessa fil-medda(meded) tal-frekwenza li fiha jopera t-tagħmir tar-radju: J166E, G8D-644M-KEY-E : 11µW GHR-M001 : 82dBµV/m [@3m] GGM-M002 : 62dBµV/m [@10m] ATTENZJONI Hemm ir-risju ta' splużjoni jekk il-batterija tkun sositwita bit-tip żbaljat. Armi l-batterji użati skont l-Istruzzjonijiet.
17_RED_NL_Dutch	
VEREENVOUDIGD E EU-CONFORMITEI TSVERKLARING	Hiermee verklaart OMRON Automotive Electronics Co. Ltd., dat J166E, GHR-M001, G8D-644M-KEY-E, GGM-M002 in overeenstemming zijn met Richtlijn 2014/53/EU. Klik voor meer informatie op de onderstaande link: http://www.mitsubishi-motors.com/en/red-doc/ Frequentieband(en) waarop de radioapparatuur werkt: J166E, G8D-644M-KEY-E : 433.92MHz GHR-M001, GGM-M002 : 125kHz Maximum radiofrequentie-vermogen doorgegeven in de frequentieband(en) waarop de radioapparatuur werkt: J166E, G8D-644M-KEY-E : 11µW GHR-M001 : 82dBµV/m [@3m] GGM-M002 : 62dBµV/m [@10m] LET OP Risico op explosie als batterij door een onjuist type wordt vervangen. Gooi gebruikte batterijen volgens de instructie weg.
18_RED_PL_Polish	
UPROSZCZONA DEKLARACJA ZGODNOŚCI UE	OMRON Automotive Electronics Co. Ltd. niniejszym oświadcza, że produkty J166E, GHR-M001, G8D-644M-KEY-E, GGM-M002 spełniają wymogi Dyrektywy 2014/53/UE. Szczegółowe informacje są dostępne pod następującym adresem URL: http://www.mitsubishi-motors.com/en/red-doc/ Pasma(-a) częstotliwości obsługiwane przez sprzęt radiowy:

	J166E, G8D-644M-KEY-E : 433.92MHz GHR-M001, GGM-M002 : 125kHz
	Maksymalna przesyłana moc o częstotliwości radiowej w paśmie (pasmach) częstotliwości obsługiwanych przez sprzęt radiowy: J166E, G8D-644M-KEY-E : 1µW GHR-M001 : 82dBµV/m [@3m] GGM-M002 : 62dBµV/m [@10m]
	UWAGA Ryzyko wybuchu w przypadku wymiany baterii na nieprawidłowy rodzaj. Zużyte baterie należy zutylizować zgodnie z instrukcjami.
19_RED_PT_Portuguese	
DECLARAÇÃO UE	Por isto, OMRON Automotive Electronics Co. Ltd., declara que J166E, GHR-M001, G8D-644M-KEY-E, GGM-M002 estão em conformidade com a Directiva
DE	2014/53/UE. Para mais detalhes, favor aceder acessar ao seguinte URL:
CONFORMIDADE	http://www.mitsubishi-motors.com/en/red-doc/
SIMPLIFICADA	Banda (s) de frequência em que o equipamento de rádio opera: J166E, G8D-644M-KEY-E : 433.92MHz GHR-M001, GGM-M002 : 125kHz
	Potência máxima de radiofrecuencia transmitida na (s) faixa (s) de frecuencia em que o equipamento de rádio opera: J166E, G8D-644M-KEY-E : 1µW GHR-M001 : 82dBµV/m [@3m] GGM-M002 : 62dBµV/m [@10m]
	CUIDADO Risco de explosão se a bateria for substituída por um tipo incorreto. Descarte as baterias usadas de acordo com as instruções.
20_RED_RO_Romanian	
DECLARAȚIA UE	Prin prezenta, OMRON Automotive Electronics Co. Ltd., declară că J166E,
DE	GHR-M001, G8D-644M-KEY-E, GGM-M002 sunt în conformitate cu Directiva
CONFORMITATE	2014/53/UE. Pentru detalii, accesați următorul URL:
SIMPLIFICATĂ	http://www.mitsubishi-motors.com/en/red-doc/
	Bandă/benzi de frecvență în care funcționează echipamentul radio: J166E, G8D-644M-KEY-E : 433.92MHz GHR-M001, GGM-M002 : 125kHz
	Puterea maximă a frecvenței radio transmisă în banda/benzile de frecvență în care funcționează echipamentul radio:

	J166E, G8D-644M-KEY-E : 1µW GHR-M001 : 82dBµV/m [@3m] GGM-M002 : 62dBµV/m [@10m]
	ATENŢIE Risc de explozie dacă bateria este înlocuită cu un tip incorect. Eliminați bateriile uzate conform instrucțiunilor.
21_RED_SK_Slovak	
ZJEDNODUŠENÉ EÚ VYHLÁSENIE O ZHODE	Spoločnosť OMRON Automotive Electronics Co. Ltd. týmto vyhlasuje, že J166E, GHR-M001, G8D-644M-KEY-E, GGM-M002 dodáva Smernicu 2014/53/EU. Podrobné informácie nájdete na nasledujúcej URL: http://www.mitsubishi-motors.com/en/red-doc/
	Frekvenčné pásma, v ktorých toto rádiové zariadenie funguje: J166E, G8D-644M-KEY-E : 433,92MHz GHR-M001, GGM-M002 : 125kHz
	Maximálna rádiová frekvencia energia prenášaná v týchto rádiových pásmach: J166E, G8D-644M-KEY-E : 1µW GHR-M001 : 82dBµV/m [@3m] GGM-M002 : 62dBµV/m [@10m]
	UPOZORNENIE Nebezpečenstvo výbuchu, ak je batéria nahradená nesprávnym typom. Použitie batérie zlikvidujte v súlade s pokynmi.
22_RED_SL_Slovenian	
POENOSTAVLJEN A IZJAVA EU O SKLADNOSTI	S tem podjetje OMRON Automotive Electronics Co. Ltd., izjavlja, da so J166E, GHR-M001, G8D-644M-KEY-E, GGM-M002 v skladu z Direktivo 2014/53/EU. Za podrobnosti odprite naslednji URL: http://www.mitsubishi-motors.com/en/red-doc/
	Frekvenčni pas(ovi) v katerih deluje radijska oprema: J166E, G8D-644M-KEY-E : 433,92MHz GHR-M001, GGM-M002 : 125kHz
	Največja radio-frekvenčna moč oddajana v frekvenčnem(ih) pasu(ovih), v katerem radijska oprema deluje: J166E, G8D-644M-KEY-E : 1µW GHR-M001 : 82dBµV/m [@3m] GGM-M002 : 62dBµV/m [@10m]
	POZOR Tveganje eksplozije v primeru, da baterijo zamenjate z napačnim tipom. Izpraznjene baterije zavrzite v skladu z navodili.

23_RED_FI_Finnish	
YKSINKERTAISTE	OMRON Automotive Electronics Co. Ltd., ilmoittaa täten, että J166E, GHR-M001, G8D-644M-KEY-E, GGM-M002 noudattaa Direktiivin 2014/53/EU vaatimuksia.
TTU	Saadaksesi isätietoja, käytä seuraavaa URL-osoitetta: http://www.mitsubishi-motors.com/en/red-doc/
EU-VAATIMUSTE	
NMUKAISUUSVA	
KUUTUS	Taajuusalue(et), joilla radiolaitte toimii: J166E, G8D-644M-KEY-E : 433.92MHz GHR-M001, GGM-M002 : 125kHz
	Suurin radioaajuudella lähetettävä teho taajuusalueilla/-alueilla, joilla radiolaitte toimii: J166E, G8D-644M-KEY-E : 11µW GHR-M001 : 82dBµV/m [@3m] GGM-M002 : 62dBµV/m [@10m]
	HUOMIO Räjähdystvaara, jos paristo vaihdetaan väärään tyyppiin. Noudata ohjeita käytettyjen paristojen hävittämisessä.
24_RED_SV_Swedish	
FÖRENKLAD	OMRON Automotive Electronics Co. Ltd. förklarar jag härmed att J166E, GHR-M001, G8D-644M-KEY-E, GGM-M002 är i enlighet med Direktiv 2014/53/EU.
EU-FÖRSÄKRAN	
OM	För detaljer vänligen använd följande webbplatsare: http://www.mitsubishi-motors.com/en/red-doc/
ÖVERENSSTÄMM	
ELSE	
	Frekvensband (er) i hvilken radio utrustning en arbetar: J166E, G8D-644M-KEY-E : 433.92MHz GHR-M001, GGM-M002 : 125kHz
	Maximala radiofrekvens makt överförs i frekvens mottagningsläger som driver radioutrustning: J166E, G8D-644M-KEY-E : 11µW GHR-M001 : 82dBµV/m [@3m] GGM-M002 : 62dBµV/m [@10m]
	FÖRSIKTIGHET Risk för explosion om batteriet ersätts av fel batterityp. Kassera använda batterier enligt instruktionerna.
25_RED_NO_Norwegian	
FORENKLET EU	Herved OMRON Automotive Electronics Co. Ltd., erklærer at J166E, GHR-M001,

KONFORMITETSE RKLÆRING	G8D-644M-KEY-E, GGM-M002 samsvar med Resolusjon 2014/53/EU. For ytterligere informasjon, vennligst sjekk følgende URL: http://www.mitsubishi-motors.com/en/red-doc/
	Frekvens bånd (s) der radioutstyret fungerer: J166E, G8D-644M-KEY-E : 433.92MHz GHR-M001, GGM-M002 : 125kHz
	Maksimal radiofrekvensen strøm ble sendt i frekvensbånd(s) som radioutstyret fungerer: J166E, G8D-644M-KEY-E : 1µW GHR-M001 : 82dBµV/m [@3m] GGM-M002 : 62dBµV/m [@10m]
	FORSIKTIG Det er fare for eksplosjon hvis batteriet er erstattet med feil type. I henhold til instruksjonene, er batteriene fjernet.
26_RED_TR_Turkish	
AB UYGUNLUK BASITLÈŞTIRILMI Ş BEYAN	OMRON Automotive Electronics Co. Ltd., şirketi J166E, GHR-M001, G8D-644M-KEY-E, GGM-M002 ürünlerinin 2014/53/EU Direktifi ile uyumlu olduğunu beyan eder. Ayrıntılar için lütfen aşağıdaki URL'ye erişin: http://www.mitsubishi-motors.com/en/red-doc/
	Radyo ekipmanının çalıştığı frekans bantları: J166E, G8D-644M-KEY-E : 433.92MHz GHR-M001, GGM-M002 : 125kHz
	Radyo ekipmanının çalıştığı frekans bantlarında ietilen maksimum radyofrekans gücü: J166E, G8D-644M-KEY-E : 1µW GHR-M001 : 82dBµV/m [@3m] GGM-M002 : 62dBµV/m [@10m]
	DİKKAT Pili, yanlış tip pille değiştirilirse, patlama riski vardır. Kullanılmış pilleri talimatlara göre imha edin.
27_RED_MK_Macedonian	
ПОДНОСТАВЕН А ДЕКЛАРАЦИЈА ЗА СОГЛАСНОСТ НА ЕУ	Со оттука, OMRON Automotive Electronics Co. Ltd. изјавува дека J166E, GHR-M001, G8D-644M-KEY-E, GGM-M002 е во согласност со Директивата 2014/53/ ЕУ. За подетални информации, отворете ја следнава УРЛ: http://www.mitsubishi-motors.com/en/red-doc/
	Радио опремата работи на следниот радиофреквенциски спектар:

	J166E, G8D-644M-KEY-E : 433.92MHz GHR-M001, GGM-M002 : 125kHz
	Радио опремата функционира на следната максимална моќност на радио фреквенци емитувана во радиофреквенцискиот спектар: J166E, G8D-644M-KEY-E : 1µW GHR-M001 : 82dBµV/m [@3m] GGM-M002 : 62dBµV/m [@10m]
	ВНИМАНИЕ Опасност од експлозија ако батеријата се замени со неправилен тип. Фрлете ги употребените батерии во согласност со упатствата.
28_RED_SQ_Albanian	
DEKLARATË THJESHTUAR SË KONFORMITETIT TË BE-SË	Këtu, OMRON Automotive Electronics Co. Ltd., deklaron se J166E, GHR-M001, G8D-644M-KEY-E, GGM-M002 janë në përputhje me Direktivën 2014/53/EU. Për hollësi, ju lutem hapni URL-në e mëposhtme: http://www.mitsubishi-motors.com/en/red-doc/
	Banda(t) e frekuencës me të cilat punojnë pajisjet radio: J166E, G8D-644M-KEY-E : 433.92MHz GHR-M001, GGM-M002 : 125kHz
	Fuqia maksimale radio-frekuencë e transmetuar në bandën(at) e frekuencave në të cilën punojnë pajisjet radio: J166E, G8D-644M-KEY-E : 1µW GHR-M001 : 82dBµV/m [@3m] GGM-M002 : 62dBµV/m [@10m]
	KUJDES Rrezik shpërthimi në qoftë se bateria është zëvendësuar nga një lloj i gabuar. Shkatërro bateritë e përdonura sipas udhëzimeve.
29_RED_XX_Montenegrin	
POJEDNOSTAVLJ ENA EU IZJAVA O USAGLAŠENOSTI	Ovim putem OMRON Automotive Electronics Co. Ltd., izjavljuje da su J166E, GHR-M001, G8D-644M-KEY-E, GGM-M002 u skladu sa Odredbom 2014/53/EU. Za više detalja, pristupite sljedećoj URL adresi: http://www.mitsubishi-motors.com/en/red-doc/
	Frekventni opseg u kojem funkcioniše radio oprema: J166E, G8D-644M-KEY-E : 433.92MHz GHR-M001, GGM-M002 : 125kHz
	Maksimalna prenesena snaga radio frekvencije u frekventnom opsegu u kojem funkcioniše radio oprema :

	<p>J166E, G8D-644M-KEY-E : 1μw GHR-M001 : 82dBμV/m [@3m] GGM-M002 : 62dBμV/m [@10m] OPREZ Postoji rizik od eksplozije ako se baterija zamijeni pogrešnom vrstom. Odložite iskorišćene baterije u skladu sa uputstvima.</p>
30_RED_KA_Georgian	
EU	<p>კომპანია OMRON Automotive Electronics Co. Ltd. აგზადებს, რომ J166E, GHR-M001, G8D-644M-KEY-E, GGM-M002 არის 2014/53/EU დირექტვის სრულ შესაბამისობაში. დაწვრილებითი ინფორმაციისთვის იხილეთ შემდეგი ბმული: http://www.mitsubishi-motors.com/en/red-doc/ სისმირეს ტალღები, რომლებზეც მუშაობს რადიო: J166E, G8D-644M-KEY-E : 433.92MHz GHR-M001, GGM-M002 : 125kHz რადიო მოწყობილობის რადიო-სიხშირის მაქსიმალური სიმძლავრე: J166E, G8D-644M-KEY-E : 1μw GHR-M001 : 82dBμV/m [@3m] GGM-M002 : 62dBμV/m [@10m] გაფრთხილება სხვა ტიპის ელემენტით შეცვლის შემთხვევაში არსებობს აფეთქების რისკი. გამოყენებული ელემენტების განკარგვის მოხდინეთ იმტრუქციის თანახმად.</p>
გამართლებული შესაბამისობის განცხადების	

A) Generic information:

Manufacturer Postal Address

ADC Automotive Distance Control Systems GmbH
Peter-Dornier-Strasse 10, 88131 Lindau, Germany

B) Language Text:

01_RED_BG_Bulgarian	
ОПРОСТЕНА ЕС ДЕКЛАРАЦИЯ ЗА СЪОТВЕТСТВИЕ	С настоящото ADC Automotive Distance Control Systems GmbH декларира, че този тип радиосъоръжение ARS 3-B е в съответствие с Директива 2014/53/ЕС. Цялостният текст на ЕС декларацията за съответствие може да се намери на следния интернет адрес: http://continental.automotive-approvals.com/ радиочестотната лента или ленти, в която или които работи радиосъоръжението: 76-77 GHz максималната радиочестотна мощност, излъчвана в радиочестотната лента или ленти, в която или които работи радиосъоръжението.: 1W (30dBm RMS EIRP)
02_RED_ES_Spanish	
DECLARACIÓN UE DE CONFORMIDAD SIMPLIFICADA	Por la presente, ADC Automotive Distance Control Systems GmbH declara que el tipo de equipo radioeléctrico ARS 3-B es conforme con la Directiva 2014/53/UE. El texto completo de la declaración UE de conformidad está disponible en la dirección Internet siguiente: http://continental.automotive-approvals.com/ Banda o bandas de frecuencia en las que opera el equipo radioeléctrico: 76-77 GHz Potencia máxima de radiofrecuencia transmitida en la banda o bandas de frecuencia en las que opera el equipo radioeléctrico: 1W (30dBm RMS EIRP)

03_RED_CS_Czech ZJEDNODUŠENÉ EU PROHLÁŠENÍ O SHODĚ	<p>Tímto ADC Automotive Distance Control Systems GmbH prohlašuje, že typ rádiového zařízení ARS 3-B je v souladu se směrnicí 2014/53/EU. Úplné znění EU prohlášení o shodě je k dispozici na této internetové adrese: http://continental.automotive-approvals.com/</p> <p>Kmitočtové pásmo (kmitočtová pásma), v němž (v nichž) rádiové zařízení pracuje: 76–77 GHz</p> <p>Maximální radiofrekvenční výkon vysílaný v kmitočtovém pásmu (v kmitočtových pásmech), v němž (v nichž) je rádiové zařízení provozováno: 1W (30dBm RMS EIRP)</p>
04_RED_DA_Danish FORENKLET EUOVERENSSTEMMELSE SERKLÆRING	<p>Hermed erklærer ADC Automotive Distance Control Systems GmbH, at radioustyretypen ARS 3-B er i overensstemmelse med direktiv 2014/53/EU.</p> <p>EUoverensstemmelseserklæringens fulde tekst kan findes på følgende internetadresse: http://continental.automotive-approvals.com/</p> <p>Frekvensbånd, som radioustyret fungerer på: 76–77 GHz</p> <p>Maksimal radiofrekvensseffekt, der udsendes i de frekvensbånd, som radioustyret fungerer på: 1W (30dBm RMS EIRP)</p>
05_RED_DE_German VEREINFACHTE EUKONFORMITÄTSERKL ÄRUNG	<p>Hiermit erklärt ADC Automotive Distance Control Systems GmbH, dass der Funkanlagentyp ARS 3-B der Richtlinie 2014/53/EU entspricht. Der vollständige Text der EU-Konformitätserklärung ist unter der folgenden Internetadresse verfügbar: http://continental.automotive-approvals.com/</p> <p>Das Frequenzband oder die Frequenzbänder, in dem bzw. denen die Funkanlage betrieben wird: 76–77 GHz</p> <p>Die in dem Frequenzband oder den Frequenzbändern, in</p>

	dem bzw. denen die Funkanlage betrieben wird, abgestrahlte maximale Sendeleistung: 1W (30dBm RMS EIRP)
06_RED_ET_Estonian LIHTSUSTATUD ELI VASTAVUSDEKLARAT SIOON	Käesolevaga deklareerib ADC Automotive Distance Control Systems GmbH, et käesolev raadioseadme tüüp ARS 3-B vastab direktiivi 2014/53/EL nõuetele. ELI vastavusdeklaratsioonil täielik tekst on kättesaadav järgmisel internetiaadressil: http://continental.automotive-approvals.com/ Sagedusriba(d), millel raadioseade töötab: 76–77 GHz Raadioseadme tööagedus(t)el edastatav maksimaalne saatevõimsus: 1W (30dBm RMS EIRP)
07_RED_EL_Greek ΑΠΛΟΥΣΤΕΥΜΕΝΗ ΔΗΛΩΣΗ ΣΥΜΜΟΡΦΩΣΗΣ ΕΕ	Με την παρούσα ο/η ADC Automotive Distance Control Systems GmbH, δηλώνει ότι ο ραδιοεξοπλισμός ARS 3-B πληροί την οδηγία 2014/53/ΕΕ. Το πλήρες κείμενο της δήλωσης συμμόρφωσης ΕΕ διατίθεται στην ακόλουθη ιστοσελίδα στο διαδίκτυο: http://continental.automotive-approvals.com/ Οι ζώνες συχνοτήτων στις οποίες λειτουργεί ο ραδιοεξοπλισμός: 76–77 GHz η μέγιστη ραδιοηλεκτρική ισχύς στις ζώνες συχνοτήτων στις οποίες λειτουργεί ο ραδιοεξοπλισμός: 1W (30dBm RMS EIRP)
08_RED_EN_English SIMPLIFIED EU DECLARATION OF CONFORMITY	Hereby, ADC Automotive Distance Control Systems GmbH declares that the radio equipment type ARS 3-B is in compliance with Directive 2014/53/EU. The full text of the EU declaration of conformity is available at the following internet address: http://continental.automotive-approvals.com/ Frequency band(s) in which the radio equipment operates:

	76-77 GHz
	Maximum radio-frequency power transmitted in the frequency band(s) in which the radio equipment operates: 1W (30dBm RMS EIRP)
09_RED_FR_French	
DECLARATION UE DE CONFORMITE SIMPLIFIEE	Le soussigné, ADC Automotive Distance Control Systems GmbH, déclare que l'équipement radioélectrique du type ARS 3-R est conforme à la directive 2014/53/UE. Le texte complet de la déclaration UE de conformité est disponible à l'adresse internet suivante: http://continental.automotive-approvals.com/
	Bandes de fréquences utilisées par l'équipement radioélectrique: 76-77 GHz
	Puissance de radiofréquence maximale transmise sur les bandes de fréquences utilisées par l'équipement radioélectrique: 1W (30dBm RMS EIRP)
10_RED_GA_empty_no_text	
Related RED Directive not released.	
11_RED_HR_Croatian	
POJEDNOSTAVLJENA EU IZJAVA O SUKLADNOSTI	ADC Automotive Distance Control Systems GmbH ovime izjavljuje da je radijska oprema tipa ARS 3-B u skladu s Direktivom 2014/53/EU. Cjeloviti tekst EU izjave o sukladnosti dostupan je na sljedećoj internetskoj adresi: http://continental.automotive-approvals.com/
	Frekvencijski pojas (frekvencijski pojas) u kojem (kojima) radijska oprema radi: 76-77 GHz
	Najveća radiofrekvencijska snaga koja se prenosi u frekvencijskom pojasu (frekvencijskim pojasima) u kojem (kojima) radijska oprema radi: 1W (30dBm RMS EIRP)
12_RED_IT_Italian	

DICHIARAZIONE DI CONFORMITÀ UE SEMPLIFICATA	Il fabbricante, ADC Automotive Distance Control Systems GmbH, dichiara che il tipo di apparecchiatura radio ARS 3-B è conforme alla direttiva 2014/53/UE. Il testo completo della dichiarazione di conformità UE è disponibile al seguente indirizzo Internet: http://continental.automotive-approvals.com/
	Bande di frequenza di funzionamento dell'apparecchiatura radio: 76-77 GHz
	Massima potenza a radiofrequenza trasmessa nelle bande di frequenza in cui opera l'apparecchiatura radio: 1W (30dBm RMS EIRP)
13_RED_LV_Latvian	
VĪENKĀRŠOTA ES ATBILSTĪBAS DEKLARĀCIJA	Ar šo ADC Automotive Distance Control Systems GmbH deklarē, ka radioiekārta ARS 3-B atbilst Direktīvai 2014/53/ES. Pilns ES atbilstības deklarācijas teksts ir pieejams šādā interneta vietnē: http://continental.automotive-approvals.com/
	Frekvenču joslu(-as), kurā(-ās) radioiekārta darbojas: 76-77 GHz
	Frekvenču joslā(-ās), kurā(-ās) darbojas radioiekārta, maksimālo pārraidītā signāla jaudu.: 1W (30dBm RMS EIRP)
14_RED_LT_Lithuanian	
SUPAPRASTINTA ES ATITIKTIES DEKLARACIJA	Aš, ADC Automotive Distance Control Systems GmbH, patvirtinu, kad radijo įrenginių tipas ARS 3-B atitinka Direktyvą 2014/53/ES. Visas ES atitikties deklaracijos tekstas prieinamas šiuo interneto adresu: http://continental.automotive-approvals.com/
	Dažnių juosta (-os), kurioje (-iose) veikia radijo įrenginiai: 76-77 GHz
	Didžiausia radijo dažnių galia, perduodama toje (tose) dažnių juostoje (-ose), kurioje (-iose) veikia radijo įrenginiai: 1W (30dBm RMS EIRP)
15_RED_HU_Hungarian	
EGYSZERŰSÍTETT	ADC Automotive Distance Control Systems GmbH igazolja,

EUMEGFELELŐSÉGI NYILATKOZAT	<p>hogya ARS 3-B típusú rádióberendezés megfelel a 2014/53/EU irányelvnek. Az EU-megfelelőségi nyilatkozat teljes szövege elérhető a következő internetes címen.: http://continental.automotive-approvals.com/</p> <p>AZ(ok) a frekvenciasáv(ok), amely(ek)en a rádióberendezés működik: 76–77 GHz</p> <p>Az abban a frekvenciasávban vagy azokban a frekvenciasávokban továbbított maximális jelerősség, amely(ek)ben a rádióberendezés üzemel: 1W (30dBm RMS EIRP)</p>
16_RED_MT_Maltese	
DIKJARAZZJONI SSIMPLIFIKATA TA' KONFORMITÀ TAL-UE	<p>B'dan, ADC Automotive Distance Control Systems GmbH, niddikjara li dan it-tip ta' tagħmir tar-radju ARS 3-B huwa konformi mad-Direttiva 2014/53/UE. It-test kollu tad-dikjarazzjoni ta' konformità tal-UE huwa disponibbli f'dan l-indirizz tal-Internet li ġej: http://continental.automotive-approvals.com/</p> <p>Il-medda/meded tal-frekwenza li jaħdem fihom it-tagħmir tar-radju: 76–77 GHz</p> <p>Il-potenza massima tal-frekwenza tar-radju trażmessa fil-medda/meded tal-frekwenza li jaħdem fihom it-tagħmir tar-radju: 1W (30dBm RMS EIRP)</p>
17_RED_NL_Dutch	
VEREENVOUDIGDE EUCONFORMITEITSVERKLARING	<p>Hierbij verklaar ik, ADC Automotive Distance Control Systems GmbH, dat het type radioapparatuur ARS 3-B conform is met Richtlijn 2014/53/EU. De volledige tekst van de EU-conformiteitsverklaring kan worden geraadpleegd op het volgende internetadres: http://continental.automotive-approvals.com/</p> <p>Frequentieband(en) waarin de radioapparatuur functioneert: 76–77 GHz</p> <p>Maximaal radiofrequent vermogen uitgezonden in de frequentieband(en) waarin de radioapparatuur functioneert:</p>

	1W (30dBm RMS EIRP)
18_RED_PL_Polish	
UPROSZCZONA DEKLARACJA ZGODNOŚCI UE	ADC Automotive Distance Control Systems GmbH niniejszym oświadcza, że typ urządzenia radiowego ARS 3-B jest zgodny z dyrektywą 2014/53/UE. Pełny tekst deklaracji zgodności UE jest dostępny pod następującym adresem internetowym: http://continental.automotive-approvals.com/ Zakres(-ów) częstotliwości, w którym (których) pracuje urządzenie radiowe: 76-77 GHz Maksymalnej mocy częstotliwości radiowej emitowanej w zakresie(-ach) częstotliwości, w którym (których) pracuje urządzenie radiowe: 1W (30dBm RMS EIRP)
19_RED_PT_Portuguese	
DECLARAÇÃO UE DE CONFORMIDADE SIMPLIFICADA	O(s) abaixo mencionado(s) ADC Automotive Distance Control Systems GmbH declara que o presente tipo de equipamento de rádio ARS 3-B está em conformidade com a Diretiva 2014/53/UE. O texto integral da declaração de conformidade está disponível no seguinte endereço de Internet: http://continental.automotive-approvals.com/ A(s) banda(s) de frequências em que o equipamento de rádio funciona: 76-77 GHz A potência máxima de radiofrequências transmitida na(s) banda(s) de frequências em que o equipamento de rádio funciona: 1W (30dBm RMS EIRP)
20_RED_RO_Romanian	
DECLARAȚIA UE DE CONFORMITATE SIMPLIFICATĂ	Prin prezenta, ADC Automotive Distance Control Systems GmbH declară că tipul de echipamente radio ARS 3-B este în conformitate cu Directiva 2014/53/UE. Textul integral al declarației UE de conformitate este disponibil la următoarea adresă internet:

	http://continental.automotive-approvals.com/
	Banda (benzile) de frecvențe în care funcționează echipamentul radio: 76–77 GHz
	Puteerea maximă de radiofrecvență transmisă în banda (benzile) de frecvențe în care funcționează echipamentul radio: 1W (30dBm RMS EIRP)
21_RED_SK_Slovak	
ZJEDNODUŠENÉ EÚ VYHLÁSENIE O ZHODE	ADC Automotive Distance Control Systems GmbH týmto vyhlasuje, že rádiové zariadenie typu ARS 3-B je v súlade so smernicou 2014/53/EÚ. Úplné EÚ vyhlásenie o zhode je k dispozícii na tejto internetovej adrese: http://continental.automotive-approvals.com/
	Frekvenčné pásmo resp. pásma, v ktorých rádiové zariadenie pracuje: 76–77 GHz
	Maximálny vysokofrekvenčný výkon prenášaný vo frekvenčnom pásme, resp. pásmach, v ktorých rádiové zariadenie pracuje: 1W (30dBm RMS EIRP)
22_RED_SL_Slovenian	
POENOSTAVLJENA IZJAVA EU O SKLADNOSTI	ADC Automotive Distance Control Systems GmbH potrjuje, da je tip radijske opreme ARS 3-B skladen z Direktivo 2014/53/EU. Celotno besedilo izjave EU o skladnosti je na voljo na naslednjem spletnem naslovu: http://continental.automotive-approvals.com/
	Frekvenčni pas ali pasovi, na katerih deluje radijska oprema: 76–77 GHz
	Največja energija za radijsko frekvenco, preneseno po frekvenčnem pasu ali pasovih, na katerih radijska oprema deluje: 1W (30dBm RMS EIRP)
23_RED_FI_Finnish	
YKSINKERTAISTETTU EUVAATIMUSTENMUKAISU	ADC Automotive Distance Control Systems GmbH vakuuttaa, että radiolaitetyyppi ARS 3-B on direktiivin

USVAKUUTUS	<p>2014/53/EU mukainen. EUvaatimustenmukaisuusvakuutuksen täysimittainen teksti on saatavilla seuraavassa internetosoitteessa: http://continental.automotive-approvals.com/</p> <p>Radiotaajuudet, jolla radiolaitte toimii: 76-77 GHz</p> <p>Suurin mahdollinen lähetysteho radiotaajuuksilla, jolla radiolaitte toimii: 1W (30dBm RMS EIRP)</p>
24_RED_SV_Swedish	
FÖRENKLAD EUFÖRSÄKRAN OM ÖVERENSSTÄMMELSE	<p>Härmed försäkrar ADC Automotive Distance Control Systems GmbH att denna typ av radioutrustning ARS 3-B överensstämmer med direktiv 2014/53/EU. Den fullständiga texten till EU-försäkran om överensstämmelse finns på följande webbadress: http://continental.automotive-approvals.com/</p> <p>Det eller de frekvensband där radioutrustningen arbetar: 76-77 GHz</p> <p>Der maximala radiofrekvensseffekt som överförs inom det eller de frekvensband där radioutrustningen arbetar: 1W (30dBm RMS EIRP)</p>

OGGE19E1

Declaration of Conformity 14- 23

C) Language Text (EFTA Countries):

01_RED_IS_Icelandic	
EINFÖLDUB ESB SAMRÆMISYFIRLÝSING	Hér með lýsir ADC Automotive Distance Control Systems GmbH því yfir, að fjarskiptabúnaðurinn að gerð ARS 3-B er í samræmi við tilskipun 2014/53/ ESB. Textinn í fullri lengd um Samræmisyfirlýsingu ESB er aðgengilegur á eftirfarandi veffangi: http://continental.automotive-approvals.com/
	Bandbreidd(ir), sem fjarskiptabúnaðurinn starfar í: 76–77 GHz
	Hámarks fjarskiptiðni serdistyrkleika í bandbreiddinni/bandbreiddunum sem fjarskiptabúnaðurinn starfar í: 1W (30dBm RMS EIRP)

D) Language Text (Custom Union Agreement between EU and Turkey):

01_RED_TR_Turkish BASITLEŞTİRİLMİŞ AB UYGUNLUK BEYANI	İşbu belge ile, ADC Automotive Distance Control Systems GmbH şirketi ARS 3-B tipi radyo ekipmanının 2014/53/AB sayılı direktife uygun olduğunu beyan eder. AB uygunluk beyanının tam metni aşağıdaki internet adresinde mevcuttur: http://continental.automotive-approvals.com/
	Radyo cihazının çalıştığı frekans bandı/bantları: 76–77 GHz
	Radyo ekipmanının çalıştığı frekans bandında/bantlarında iletilen maksimum radio frekansı gücü: 1W (30dBm RMS EIRP)

A) Generic information:

Manufacturer Postal Address

ADC Automotive Distance Control Systems GmbH
Peter-Dornier-Strasse 10, 88131 Lindau, Germany

B) Language Text:

01_RED_BG_Bulgarian	<p>С настоящото ADC Automotive Distance Control Systems GmbH декларира, че този тип радиосъоръжение SRR 3-A е в съответствие с Директива 2014/53/EU.</p> <p>Цялостният текст на ЕС декларацията за съответствие може да се намери на следния интернет адрес: http://continental.automotive-approvals.com/</p> <p>радиочестотната лента или ленти, в която или които работи радиосъоръжението: 24.05–24.25 GHz</p> <p>максималната радиочестотна мощност, използвана в радиочестотната лента или ленти, в която или които работи радиосъоръжението.: 100mW (20 dBm) Peak EIRP</p>
02_RED_ES_Spanish	<p>Por la presente, ADC Automotive Distance Control Systems GmbH declara que el tipo de equipo radioeléctrico SRR 3-A es conforme con la Directiva 2014/53/UE. El texto completo de la declaración UE de conformidad está disponible en la dirección Internet siguiente: http://continental.automotive-approvals.com/</p> <p>Banda o bandas de frecuencia en las que opera el equipo radioeléctrico: 24.05–24.25 GHz</p> <p>Potencia máxima de radiofrecuencia transmitida en la banda o bandas de frecuencia en las que opera el equipo radioeléctrico: 100mW (20 dBm) Peak EIRP</p>
03_RED_CS_Czech	<p>Tímto ADC Automotive Distance Control Systems GmbH prohlašuje, že typ rádiového zařízení SRR 3-A je v souladu se směrnici 2014/53/EU. Uplňné znění EU prohlášení o shodě je k dispozici na této internetové adrese: http://continental.automotive-approvals.com/</p> <p>Kmitočtové pásmo (kmitočtová pásma), v němž (v nichž) rádiové zařízení pracuje: 24.05–24.25 GHz</p> <p>Maximální radiofrekvenční výkon vysílání v kmitočtovém pásmu (v kmitočtových pásmech), v němž (v nichž) je rádiové zařízení provozováno: 100mW (20 dBm) Peak EIRP</p>
04_RED_DA_Danish	<p>Hermed erklærer ADC Automotive Distance Control Systems GmbH, at radioudstyretypen SRR 3-A er i overensstemmelse med direktiv 2014/53/EU.</p> <p>Euoverensstemmelseserklæringens fulde tekst kan findes på følgende internetadresse: http://continental.automotive-approvals.com/</p> <p>Frekvensbånd, som radioudstyret fungerer på: 24.05–24.25 GHz</p> <p>Maksimal radiofrekvensseffekt, der udsendes i de frekvensbånd, som radioudstyret fungerer på: 100mW (20 dBm) Peak EIRP</p>
05_RED_DE_German	<p>Hiermit erklärt ADC Automotive Distance Control Systems GmbH, dass der Funkanlagentyp SRR 3-A der Richtlinie 2014/53/EU entspricht. Der vollständige Text der EU-Konformitätserklärung ist unter der folgenden Internetadresse verfügbar: http://continental.automotive-approvals.com/</p> <p>Das Frequenzband oder die Frequenzbänder, in dem bzw. denen die Funkanlage betrieben wird: 24.05–24.25 GHz</p> <p>Die in dem Frequenzband oder den Frequenzbändern, in dem bzw. denen die</p>

	Funkilajge betrieben wird, abgestrahlte maximale Sendeleistung: 100mW (20 dBm) Peak EIRP
06_RED_ET_Estonian	
LIHTSUSTATUD ELI VASTAVUSDEKLA RATSIOON	Käesolevaga deklareerib ADC Automotive Distance Control Systems GmbH, et käesolev raadioseadme tüüp SRR 3-A vastab direktiivi 2014/53/EL nõuetele. Eli vastavusdeklaratsiooni täielik tekst on käitessaadav järgmisel internetiaadressil: http://continental.automotive-approvals.com/
	Sagedusriba(d), millel raadioseade töötab: 24.05–24.25 GHz
	Raadioseadme tööseadus(t)el edastatav maksimaalne saatevõimsus: 100mW (20 dBm) Peak EIRP
07_RED_EL_Greek	
ΑΠΛΟΥΣΤΕΥΜΕΝΗ ΔΗΛΩΣΗ ΣΥΜΜΟΡΦΩΣΗΣ ΕΕ	Με την παρούσα ο/η ADC Automotive Distance Control Systems GmbH, δηλώνει ότι ο ραδιοεξοπλισμός SRR 3-A πληροί την οδηγία 2014/53/ΕΕ. Το πλήρες κείμενο της δηλώσεως συμμόρφωσης ΕΕ διατίθεται στην ακόλουθη ιστοσελίδα στο διαδίκτυο: http://continental.automotive-approvals.com/
	Οι ζώνες συχνότητων στις οποίες λειτουργεί ο ραδιοεξοπλισμός:· 24.05–24.25 GHz
	η μέγιστη ραδιοηλεκτρική ισχύς στις ζώνες συχνότητων στις οποίες λειτουργεί ο ραδιοεξοπλισμός: 100mW (20 dBm) Peak EIRP
08_RED_EN_English	
SIMPLIFIED EU DECLARATION OF CONFORMITY	Hereby, ADC Automotive Distance Control Systems GmbH declares that the radio equipment type SRR 3-A is in compliance with Directive 2014/53/EU. The full text of the EU declaration of conformity is available at the following internet address: http://continental.automotive-approvals.com/
	Frequency band(s) in which the radio equipment operates: 24.05–24.25 GHz
	Maximum radio-frequency power transmitted in the frequency band(s) in which the radio equipment operates: 100mW (20 dBm) Peak EIRP
09_RED_FR_French	
DECLARATION UE DE CONFORMITE SIMPLIFIEE	Le soussigné, ADC Automotive Distance Control Systems GmbH, déclare que l'équipement radioélectrique du type SRR 3-A est conforme à la directive 2014/53/UE. Le texte complet de la déclaration UE de conformité est disponible à l'adresse internet suivante: http://continental.automotive-approvals.com/
	Bandes de fréquences utilisées par l'équipement radioélectrique: 24.05–24.25 GHz
	Puissance de radiofréquence maximale transmise sur les bandes de fréquences utilisées par l'équipement radioélectrique: 100mW (20 dBm) Peak EIRP
10_RED_Is_Icelandic	
	Related RED Directive not released.
11_RED_HR_Croatian	
POJEDNOSTAVLJE NA EU IZJAVA O SUKLADNOSTI	ADC Automotive Distance Control Systems GmbH ovime izjavljuje da je radijska oprema tipa SRR 3-A u skladu s Direktivom 2014/53/EU. Cjeloviti tekst EU izjave o sukladnosti dostupan je na sljedećoj internetskoj adresi: http://continental.automotive-approvals.com/
	Frekvencijski pojasi (frekvencijski pojasi) u kojim (kojima) radijska oprema radi: 24.05–24.25 GHz
	Najveća radiofrekvencijska snaga koja se prenosi u frekvencijskom pojasu (frekvencijskim pojasi) u kojem (kojima) radijska oprema radi: 100mW (20 dBm) Peak EIRP
12_RED_IT_Italian	
DICHIARAZIONE DI CONFORMITA UE SEMPLIFICATA	Il fabbricante, ADC Automotive Distance Control Systems GmbH, dichiara che il tipo di apparecchiatura radio SRR 3-A è conforme alla direttiva 2014/53/UE. Il testo completo della dichiarazione di conformità UE è disponibile al seguente indirizzo Internet: http://continental.automotive-approvals.com/
	Bande di frequenza di funzionamento dell'apparecchiatura radio: 24.05–24.25 GHz
	Massima potenza a radiofrequenza trasmessa nelle bande di frequenza in cui opera l'apparecchiatura radio:

	100mW (20 dBm) Peak EIRP
13_RED_LV_Latvian	
VIENKARSĪTA ES ATBILSTĪBAS DEKLARĀCIJA	Ar šo ADC Automotive Distance Control Systems GmbH deklarē, ka radioiekārta SRR 3-A atbilst Direktīvai 2014/53/ES. Pils ES atbilstības deklarācijas teksts ir pieejams šādā internetā vietnē: http://continental.automotive-approvals.com/
	Frekvencu joslu(-as), kurā(-ās) radioiekārta darbojas: 24.05–24.25 GHz
	Frekvencu josla(-ās), kurā(-ās) darbojas radioiekārta, maksimālo pārraidītā signāla jaudu: 100mW (20 dBm) Peak EIRP
14_RED_LT_Lithuanian	
SUPAPRĀSTĪNĀTA ES ATLIKĻĪES DEKLARĀCIJA	Aš, ADC Automotive Distance Control Systems GmbH, patvirtinu, kad radio ierīcinių tipas SRR 3-A atbilst Direktīvai 2014/53/ES. Visas ES atbilstības deklarācijas tekstas pieņemamas šio interneta adresē: http://continental.automotive-approvals.com/
	Dabūņu juosta (-os), kurioje veikia radijo ierīginiai: 24.05–24.25 GHz
	Didžiausia radijo dažnių galia, perduodama toje (tose) dažnių juostoje (-ose), kurioje (-iose) veikia radijo ierīginiai: 100mW (20 dBm) Peak EIRP
15_RED_HU_Hungarian	
EGYSZERŰSÍTETT EUMEGFELELŐSÉGI NYILATKOZAT	ADC Automotive Distance Control Systems GmbH igazolja, hogy a SRR 3-A típusú rádióberendezés megfelel a 2014/53/EU irányelvnek. Az EU-megfelelőségi nyilatkozat teljes szövege elérhető a következő internetes címen: http://continental.automotive-approvals.com/
	Az(ok) a frekvenciasáv(ok), amely(ek)en a rádióberendezés működik: 24.05–24.25 GHz
	Az abban a frekvenciasávban vagy azokban a frekvenciasávokban továbbított maximális teljesítmény, amely(ek)en a rádióberendezés üzemel: 100mW (20 dBm) Peak EIRP
16_RED_MT_Maltese	
DIKKJARAZZJONI SSIMPLIFIKATA TA' KONFORMITÀ TALUE	B'dan, ADC Automotive Distance Control Systems GmbH, nidkljara li dan it-tip ta' tagħmir tar-radju SRR 3-A huwa konformi mad-Direttiva 2014/53/UE. Il-test kollu tad-dikjarazzjoni ta' konformità tal-UE huwa disponibbli f'dan l-indirizz tal-Internet li ġej: http://continental.automotive-approvals.com/
	Il-medda/meded tal-frekwenza li jgħdem fihom it-tagħmir tar-radju: 24.05–24.25 GHz
	Il-potenza massima tal-frekwenza tar-radju trażmessa fil-medda/meded tal-frekwenza li jgħdem fihom it-tagħmir tar- radju: 100mW (20 dBm) Peak EIRP
17_RED_NL_Dutch	
VEREENVOUDIGDE EUCONFORMITEITSV ERKLARING	Hierbij verklaar ik, ADC Automotive Distance Control Systems GmbH, dat het type radioapparaat SRR 3-A conform is met Richtlijn 2014/53/EU. De volledige tekst van de EU-conformiteitsverklaring kan worden geraadpleegd op het volgende internetadres: http://continental.automotive-approvals.com/
	Frequentieband(en) waarin de radioapparaat functioneert: 24.05–24.25 GHz
	Maximaal radiofrequent vermogen uitgezonden in de frequentieband(en) waarin de radioapparaat functioneert: 100mW (20 dBm) Peak EIRP
18_RED_PL_Polish	
UPROSZCZONA DEKLARACJA ZGODNOŚCI UE	ADC Automotive Distance Control Systems GmbH niniejszym oświadczam, że typ urządzenia radiowego SRR 3-A jest zgodny z dyrektywą 2014/53/UE. Pełny tekst deklaracji zgodności UE jest dostępny pod następującym adresem internetowym: http://continental.automotive-approvals.com/
	Zakres(-ów) częstotliwości, w którym (których) pracuje urządzenie radiowe: 24.05–24.25 GHz
	Maksymalnej mocy częstotliwości radiowej emitowanej w zakresie(-ach) częstotliwości, w którym (których) pracuje urządzenie radiowe: 100mW (20 dBm) Peak EIRP
19_RED_PT_Portuguese	

DECLARAÇÃO UE DE CONFORMIDADE SIMPLIFICADA	O(a) abaixo assinado(a) ADC Automotive Distance Control Systems GmbH declara que o presente tipo de equipamento de rádio SRR 3-A está em conformidade com a Diretiva 2014/53/UE. O texto integral da declaração de conformidade está disponível no seguinte endereço de Internet: http://continental.automotive-approvals.com/
	A(s) banda(s) de frequências em que o equipamento de rádio funciona: 24.05–24.25 GHz
	A potência máxima de radiofrequências transmitida na(s) banda(s) de frequências em que o equipamento de rádio funciona: 100mW (20 dBm) Peak EIRP
20_RED_RO_Romanian	
DECLARAȚIA UE DE CONFORMITATE SIMPLIFICATĂ	Prin prezenta, ADC Automotive Distance Control Systems GmbH declară că tipul de echipamente radio SRR 3-A este în conformitate cu Directiva 2014/53/UE. Textul integral al declarației UE de conformitate este disponibil la următoarea adresă Internet: http://continental.automotive-approvals.com/
	Banda (benzile) de frecvențe în care funcționează echipamentul radio: 24.05–24.25 GHz
	Puterea maximă de radiofrecvență transmisă în banda (benzile) de frecvențe în care funcționează echipamentul radio: 100mW (20 dBm) Peak EIRP
21_RED_SK_Slovak	
ZJEDNODUŠENÉ EU VYHLÁSENIE O ZHODE	ADC Automotive Distance Control Systems GmbH týmto vyhlásuje, že rádiové zariadenie typu SRR 3-A je v súlade so smernicou 2014/53/EÚ. Uplné EU vyhlásenie o zhode je k dispozícii na tejto internetovej adrese: http://continental.automotive-approvals.com/
	Frekvenčné pásmo resp. pásma, v ktorých rádiové zariadenie pracuje: 24.05–24.25 GHz
	Maximálny vysokofrekvenčný výkon prenášaný vo frekvenčnom pásme, resp. pásmach, v ktorých rádiové zariadenie pracuje: 100mW (20 dBm) Peak EIRP
22_RED_SL_Slovenian	
POENOSTAVLJENA IZJAVA EU O SKLADNOSTI	ADC Automotive Distance Control Systems GmbH potrjuje, da je tip radijske opreme SRR 3-A skladen z Direktivo 2014/53/EU. Celotno besedilo izjave EU o skladnosti je na voljo na naslednjem spletnem naslovu: http://continental.automotive-approvals.com/
	Frekvenčni pas ali pasovi, na katerih deluje radijska oprema: 24.05–24.25 GHz
	Maximalni visokofrekvenčni výkon prenašani v frekvenčnem pasu ali pasovih, na katerih radijska oprema deluje: 100mW (20 dBm) Peak EIRP
23_RED_FL_Finnish	
YKSINKERTAISTETTU EU VAATIMUSTENMUKAISUUSVAKUUTUS	ADC Automotive Distance Control Systems GmbH vakuuttaa, että radiolaitetyyppi SRR 3-A on direktiivin 2014/53/EU mukainen. EU-vaatimustenmukaisuusvakuutukseen löysmittainen teksti on saatavilla seuraavassa Internetosoitteessa: http://continental.automotive-approvals.com/
	Radiotaajuudet, joilla radiolaitte toimii: 24.05–24.25 GHz
	Suurin mahdollinen lähetysteho radiotaajuuksilla, joilla radiolaitte toimii: 100mW (20 dBm) Peak EIRP
24_RED_SV_Swedish	
FÖRENKLAD EU-FÖRSÄKRAN OM ÖVERENSSTÄMME LSE	Härmed försäkrar ADC Automotive Distance Control Systems GmbH att denna typ av radioutrustning SRR 3-A överensstämmer med direktiv 2014/53/EU. Den fullständiga texten till EU-försäkran om överensstämmelse finns på följande webbadress: http://continental.automotive-approvals.com/
	Det eller de frekvensband där radioutrustningen arbetar: 24.05–24.25 GHz
	Den maximala radiofrekvenseffekt som överförs inom det eller de frekvensband där radioutrustningen arbetar: 100mW (20 dBm) Peak EIRP

C) Language Text (EFTA Countries):

SRR3-A : OUTLANDER / OUTLANDER PHEV / ECLIPSE CROSS

01_RED_IS_Icelandic	
EINFÖLDUÐ ESB SAMRÆMISYFIRLÝSING	Hér með lýsir ADC Automotive Distance Control Systems GmbH því yfir, að fjarskiptabúnaðurinn að gerð SRR 3-A er í samræmi við tilskipun 2014/53/ESB. Textinn í fullri lengd um Samræmisyfirlýsingu ESB er aðgengilegur á eftirfarandi veffangi: http://continental.automotive-approvals.com/
	Bandbreidd(ir), sem fjarskiptabúnaðurinn starfar í: 24.05–24.25 GHz
	Hámarks fjarskiptiðni sendistyrkleika í bandbreiddinni/bandbreiddunum sem fjarskiptabúnaðurinn starfar í: 100mW (20 dBm) Peak EIRP

D) Language Text (Custom Union Agreement between EU and Turkey):

SRR3-A : OUTLANDER / OUTLANDER PHEV / ECLIPSE CROSS

01_RED_TR_Turkish	
BASİTLEŞTİRİLMİŞ AB UYGUNLUK BEYANI	İşbu belge ile, ADC Automotive Distance Control Systems GmbH şirketi SRR 3-A tipi radyo ekipmanının 2014/53/AB sayılı direktife uygun olduğunu beyan eder. AB uygunluk beyanının tam metni aşağıdaki İnternet adresinde mevcuttur: http://continental.automotive-approvals.com/
	Radyo cihazının çalıştığı frekans bandı/bantları: 24.05–24.25 GHz
	Radyo ekipmanının çalıştığı frekans bandında/bantlarında iletilen maksimum radyo frekansı gücü: 100mW (20 dBm) Peak EIRP

OGGE19E1

Declaration of Conformity

14- 29

A) Generic information:

Manufacture Postal Address
 VISTEON CORPORATION
 One Village Center Drive, Van Buren Township, Michigan USA

B) Language Text:

01_RED_BG_Bulgarian	
ОПРОСТЕНА ЕС ДЕКЛАРАЦИЯ ЗА СЪОТВЕТСТВИЕ	С настоящото VISTEON CORPORATION декларира, че този тип радиосъоръжение MDGMU10 е в съответствие с Директива 2014/53/ЕС. Цялостният текст на ЕС Декларацията за съответствие може да се намери на следния интернет адрес: http://www.mitsubishi-motors.co.jp/en/red-doc/ радиочестотната лента или ленти, в която или които работи радиосъоръжението: 2.402-2.480 GHz максималната радиочестота на мощност, излъчвана в радиочестотната лента или ленти, в която или които работи радиосъоръжението.: 4 dbm
02_RED_ES_Spanish	
DECLARACIÓN UE DE CONFORMIDAD SIMPLIFICADA	Por la presente, VISTEON CORPORATION declara que el tipo de equipo radioeléctrico MDGMU10 es conforme con la Directiva 2014/53/UE. El texto completo de la declaración UE de conformidad está disponible en la dirección Internet siguiente: http://www.mitsubishi-motors.co.jp/en/red-doc/ Banda o bandas de frecuencia en las que opera el equipo radioeléctrico: 2.402-2.480 GHz Potencia máxima de radiofrecuencia transmitida en la banda o bandas de frecuencia en las que opera el equipo radioeléctrico:

	4 dbm
03_RED_CS_Czech	
ZJEDNODUŠENÉ EU PROHLÁŠENÍ O SHODĚ	Tímto VISTEON CORPORATION prohlašuje, že typ rádiového zařízení MDGMY10 je v souladu se směrnici 2014/53/EU. Úplné znění EU prohlášení o shodě je k dispozici na této internetové adrese: http://www.mitsubishi-motors.co.jp/en/red-doc/
	Kmitočtové pásmo (kmitočtová pásma), v němž (v nichž) rádiové zařízení pracuje: 2.402-2.480 GHz
	Maximální radiofrekvenční výkon vysílaný v kmitočtovém pásmu (v kmitočtových pásmech), v němž (v nichž) je rádiové zařízení provozováno: 4 dbm
04_RED_DA_Danish	
FORENKLET EUOVERENSSTEMM ELSEERKLÆRER NG	Hermed erklærer VISTEON CORPORATION, at radioudstyretypen MDGMY10 er i overensstemmelse med direktiv 2014/53/EU. EUoverensstemmelseserklæringens fulde tekst kan findes på følgende internetadresse: http://www.mitsubishi-motors.co.jp/en/red-doc/
	Frekvensbånd, som radioudstyret fungerer på: 2.402-2.480 GHz
	Maksimal radiofrekvensseffekt, der udsendes i de frekvensbånd, som radioudstyret fungerer på: 4 dbm
05_RED_DE_German	
VEREINFACHTE EUKONFORMITÄTserKLÄRUNG	Hiermit erklärt VISTEON CORPORATION, dass der Funkanlagentyp MDGMY10 der Richtlinie 2014/53/EU entspricht. Der vollständige Text der EU-Konformitätserklärung ist unter der folgenden Internetadresse verfügbar: http://www.mitsubishi-motors.co.jp/en/red-doc/
	Das Frequenzband oder die Frequenzbänder, in dem bzw.

	<p>denen die Funkanlage betrieben wird: 2.402-2.480 GHz</p> <p>Die in dem Frequenzband oder den Frequenzbändern, in dem bzw. denen die Funkanlage betrieben wird, abgestrahlte maximale Sendeleistung: 4 dbm</p>
06_RED_ET_Estonian	
LIHTSUSTATUD ELI VASTAVUSDEKLARATSIOON	<p>Käesolevaga deklareerib VISTEON CORPORATION, et käesolev raadioseadme tüüp MDGMY10 vastab direktiivi 2014/53/EL nõuetele. ELi vastavusdeklaratsiooni täielik tekst on kättesaadav järgmisel internetiaadressil: http://www.mitsubishi-motors.co.jp/en/red-doc/</p> <p>Sagedusriba(d), millel raadioseade töötab: 2.402-2.480 GHz</p> <p>Raadioseadme töösagedus(i)el edastatav maksimaalne saatevõimsus: 4 dbm</p>
07_RED_EL_Greek	
ΑΠΛΟΣΤΕΥΜΕΝΗ ΔΗΛΩΣΗ ΣΥΜΜΟΡΦΩΣΗΣ ΕΕ	<p>Με την παρούσα ο/η VISTEON CORPORATION, δηλώνει ότι ο ραδιοεξοπλισμός MDGMY10 πληροί την οδηγία 2014/53/ΕΕ. Το πλήρες κείμενο της δήλωσης συμμόρφωσης ΕΕ διατίθεται στην ακόλουθη ιστοσελίδα στο διαδίκτυο: http://www.mitsubishi-motors.co.jp/en/red-doc/</p> <p>Οι ζώνες συχνοτήτων στις οποίες λειτουργεί ο ραδιοεξοπλισμός:: 2.402-2.480 GHz</p> <p>η μέγιστη ραδιοηλεκτρική ισχύς στις ζώνες συχνοτήτων στις οποίες λειτουργεί ο ραδιοεξοπλισμός: 4 dbm</p>
08_RED_EN_English	

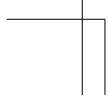
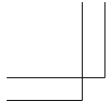

SIMPLIFIED EU DECLARATION OF CONFORMITY	<p>Hereby, VISTEON CORPORATION declares that the radio equipment type MDGM/Y10 is in compliance with Directive 2014/53/EU. The full text of the EU declaration of conformity is available at the following internet address: http://www.mitsubishi-motors.co.jp/en/red-doc/</p> <p>Frequency band(s) in which the radio equipment operates: 2.402-2.480 GHz</p> <p>Maximum radio-frequency power transmitted in the frequency band(s) in which the radio equipment operates: 4 dbm</p>
09_RED_FR_French	
DECLARATION UE DE CONFORMITE SIMPLIFIEE	<p>Le soussigné, VISTEON CORPORATION, déclare que l'équipement radioélectrique du type MDGM/Y10 est conforme à la directive 2014/53/UE. Le texte complet de la déclaration UE de conformité est disponible à l'adresse internet suivante: http://www.mitsubishi-motors.co.jp/en/red-doc/</p> <p>Bandes de fréquences utilisées par l'équipement radioélectrique: 2.402-2.480 GHz</p> <p>Puissance de radiofréquence maximale transmise sur les bandes de fréquences utilisées par l'équipement radioélectrique: 4 dbm</p>
10_RED_GA_empty_no_text	
11_RED_HR_Croatian	
POJEDNOSTAVLJENA EU IZJAVA O SUKLADNOSTI	<p>VISTEON CORPORATION ovime izjavljuje da je radijska oprema tipa MDGM/Y10 u skladu s Direktivom 2014/53/EU. Cjeloviti tekst EU izjave</p>

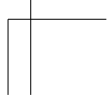
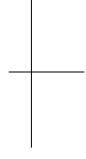
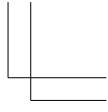

	o sukladnosti dostupan je na slijedećoj internetskoj adresi: http://www.mitsubishi-motors.co.jp/en/red-doc/
	Frekvencijski pojas (frekvencijski pojas) u kojem (kojima) radijska oprema radi: 2.402-2.480 GHz
	Najveća radiofrekvencijska snaga koja se prenosi u frekvencijskom pojasu (frekvencijskim pojasima) u kojem (kojima) radijska oprema radi: 4 dbm
12_RED_IT_Italian	
DICHIARAZIONE DI CONFORMITÀ UE SEMPLIFICATA	Il fabbricante, VISTEON CORPORATION, dichiara che il tipo di apparecchiatura radio MDGMY10 è conforme alla direttiva 2014/53/UE. Il testo completo della dichiarazione di conformità UE è disponibile al seguente indirizzo Internet: http://www.mitsubishi-motors.co.jp/en/red-doc/
	Bande di frequenza di funzionamento dell'apparecchiatura radio: 2.402-2.480 GHz
	Massima potenza a radiofrequenza trasmessa nelle bande di frequenza in cui opera l'apparecchiatura radio: 4 dbm
13_RED_LV_Latvian	
VIENKĀRŠOTA ES ATBILSTĪBAS DEKLARĀCIJA	Ar šo VISTEON CORPORATION deklarē, ka radioiekārta MDGMY10 atbilst Direktīvai 2014/53/ES. Pilns ES atbilstības deklarācijas teksts ir pieejams šādā interneta vietnē: http://www.mitsubishi-motors.co.jp/en/red-doc/
	Frekvenču joslu(-as), kurā(-ās) radioiekārta darbojas: 2.402-2.480 GHz
	Frekvenču joslā(-ās), kurā(-ās) darbojas radioiekārta, maksimālo pārraidītā signāla jaudu:

	4 dbm
14_RED_LT_Lithuanian	
SUPAPRASTINTA ES ATITIKTIES DEKLARACIJA	Aš, VISTEON CORPORATION, patvirtinu, kad radio įrenginių tipas MDGMY10 atitinka Direktyvą 2014/53/ES. Visas ES atitikties deklaracijos tekstas prieinamas šiuo interneto adresu: http://www.mitsubishi-motors.co.jp/en/red-doc/
	Dažnių juosta (-os), kurioje (-iose) veikia radio įrenginiai: 2.402-2.480 GHz
	Didžiausia radijo dažnių galia, perduodama toje (tose) dažnių juostoje (-ose), kurioje (-iose) veikia radio įrenginiai: 4 dbm
15_RED_HU_Hungarian	
EGYSZERŪSÍTETT EUMEGFELELŐSÉGI NYILATKOZAT	VISTEON CORPORATION igazolja, hogy a MDGMY10 típusú rádióberendezés megfelel a 2014/53/EU irányelvnek. Az EU megfeleléségi nyilatkozat teljes szövege elérhető a következő internetes címen: http://www.mitsubishi-motors.co.jp/en/red-doc/
	Az(ok) a frekvenciasáv(ok), amely(ek)en a rádióberendezés működik: 2.402-2.480 GHz
	Az abban a frekvenciasávban vagy azokban a frekvenciasávokban továbbiott maximális jelerősség, amely(ek)ben a rádióberendezés üzemel: 4 dbm
16_RED_MT_Maltese	
DIKJARAZZJONI SSIMPLIFIKATA TA' KONFORMITÀ TAL-UE	B'dan, VISTEON CORPORATION, niddikjara li dan it-tip ta' taghmir tar-radju MDGMY10 huwa konformi mad-Diretiva 2014/53/UE. It-test kollu tad-dikjarazzjoni ta' konformità tal-UE huwa disponibbli f'dan l-indirizz tal-Internet li ġej: http://www.mitsubishi-motors.co.jp/en/red-doc/
	Il-medda/meded tal-frekwenza li jgħdem fihom it-taghmir

	tar-radju: 2.402-2.480 GHz
	Il-potenza massima tal-frekwenza tar-radju, trażmessa fil-medda/meded tal-frekwenza li jahdem fihom it-tagħmir tar- radju: 4 dbm
17_RED_NL_Dutch	
VEREENVOUDIGDE EUCONFORMITEITSVERKLARING	Hierbij verklaar ik, VISTEON CORPORATION, dat het type radioapparaat MDGMY10 conform is met Richtlijn 2014/53/EU. De volledige tekst van de EU-conformiteitsverklaring kan worden geraadpleegd op het volgende internetadres: http://www.mitsubishi-motors.co.jp/en/red-doc/
	Frequentieband(en) waarin de radioapparaat functioneert: 2.402-2.480 GHz
	Maximaal radiofrequent vermogen uitgezonden in de frequentieband(en) waarin de radioapparaat functioneert: 4 dbm
18_RED_PL_Polish	
UPROSZCZONA DEKLARACJA ZGODNOŚCI UE	VISTEON CORPORATION niniejszym oświadcza, że typ urządzenia radiowego MDGMY10 jest zgodny z dyrektywą 2014/53/UE. Pełny tekst deklaracji zgodności UE jest dostępny pod następującym adresem internetowym: http://www.mitsubishi-motors.co.jp/en/red-doc/
	Zakres(-ów) częstotliwości, w którym (których) pracuje urządzenie radiowe: 2.402-2.480 GHz
	Maksymalnej mocy częstotliwości radiowej emitowanej w zakresie(-ach) częstotliwości, w którym (których) pracuje urządzenie radiowe: 4 dbm
19_RED_PT_Portuguese	
DECLARAÇÃO UE DE CONFORMIDADE	O(a) abaixo assinado(a) VISTEON CORPORATION declara que o presente tipo de equipamento de rádio

SIMPLIFICADA	<p>MDGMY10 está em conformidade com a Diretiva 2014/53/UE. O texto integral da declaração de conformidade está disponível no seguinte endereço de Internet: http://www.mitsubishi-motors.co.jp/en/red-doc/</p> <p>A(s) banda(s) de frequências em que o equipamento de rádio funciona: 2.402-2.480 GHz</p> <p>A potência máxima de radiofrequências transmitida na(s) banda(s) de frequências em que o equipamento de rádio funciona: 4 dbm</p>
20_RED_RO_Romanian DECLARAȚIA UE DE CONFORMITATE SIMPLIFICATĂ	<p>Prin prezenta, VISTEON CORPORATION declară că tipul de echipamente radio MDGMY10 este în conformitate cu Directiva 2014/53/UE. Textul integral al declarației UE de conformitate este disponibil la următoarea adresă internet: http://www.mitsubishi-motors.co.jp/en/red-doc/</p> <p>Banda (benzile) de frecvențe în care funcționează echipamentul radio: 2.402-2.480 GHz</p> <p>Puterea maximă de radiofrecvență transmisă în banda (benzile) de frecvențe în care funcționează echipamentul radio: 4 dbm</p>
21_RED_SK_Slovak ZJEDNODUŠENÉ EÚ VYHLÁSENIE O ZHODE	<p>VISTEON CORPORATION týmto vyhlasuje, že rádiové zariadenie typu MDGMY10 je v súlade so smernicou 2014/53/EÚ. Úplné EÚ vyhlásenie o zhode je k dispozícii na tejto internetovej adrese: http://www.mitsubishi-motors.co.jp/en/red-doc/</p> <p>Frekvenčné pásmo resp. pásma, v ktorých rádiové zariadenie pracuje: 2.402-2.480 GHz</p>

	Maximálny vysokofrekvenčný výkon prenášaný vo frekvenčnom pásme, resp. pásmach, v ktorých rádiové zariadenie pracuje: 4 dbm
22_RED_SL_Slovenian	
POENOSTAVLJENA IZJAVA EU O SKLADNOSTI	VISTEON CORPORATION potrjuje, da je tip radijske opreme MDGMY10 skladen z Direktivo 2014/53/EU. Celotno besedilo izjave EU o skladnosti je na voljo na naslednjem spletnem naslovu: http://www.mitsubishi-motors.co.jp/en/red-doc/ Frekvenčni pas ali pasovi, na katerih deluje radijska oprema: 2.402-2.480 GHz Največja energija za radijsko frekvenco, preneseno po frekvenčnem pasu ali pasovih, na katerih radijska oprema deluje: 4 dbm
23_RED_FI_Finnish	
YKSINKERTAISTETTU EUVAATIMUSTENMUKAISUUSVAKUUTUS	VISTEON CORPORATION vakuuttaa, että radiolaitetyyppi MDGMY10 on direktiivin 2014/53/EU mukainen. EUvaatimustenmukaisuusvakuutuksen täysimittainen teksti on saatavilla seuraavassa internetosoitteessa: http://www.mitsubishi-motors.co.jp/en/red-doc/ Radiotaajuudet, joilla radiolaitte toimii: 2.402-2.480 GHz Suurin mahdollinen lähetysteho radiotaajuuksilla, joilla radiolaitte toimii: 4 dbm
24_RED_SV_Swedish	
FÖRENKLAD EUFÖRSÄKRAN OM ÖVERENSSTÄMMELSE	Härmed försäkrar VISTEON CORPORATION att denna typ av radioutrustning MDGMY10 överensstämmer med direktiv 2014/53/EU. Den fullständiga texten till EU-försäkran om överensstämmelse finns på följande webbadress:

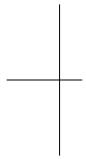
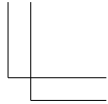
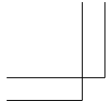

	http://www.mitsubishi-motors.co.jp/en/red-doc/
	Det eller de frekvensband där radioutrustningen arbetar: 2.402-2.480 GHz
	Den maximala radiofrekvensseffekt som överförs inom det eller de frekvensband där radioutrustningen arbetar: 4 dbm

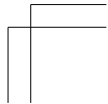
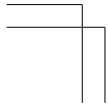
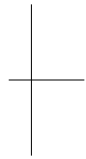

A) Generic information:**Manufacturer Postal Address**

Shanghai Kostal-Huayang Automotive Electric Co., Ltd.
No. 77 Yuan Gao Road, Fangtai, Jiading, Shanghai 201814

B) Language Text:

01_RED_BG_Bulgarian	
ОПРОСТЕНА ЕС ДЕКЛАРАЦИЯ ЗА СЪОТВЕТСТВИЕ	С настоящото [Shanghai Kostal-Huayang Automotive Electric Co., Ltd.] декларира, че този тип радиосъоръжение [EV Remote K9499-002] е в съответствие с Директива 2014/53/ЕС. Цялостният текст на ЕС декларацията за съответствие може да се намери на следния интернет адрес: http://www.mitsubishi-motors.com/en/red-doc/ радиочестотната лента или ленти, в която или които работи радиосъоръжението: 802.11b 2.4G-2.4835GHz максималната радиочестотна мощност, излъчвана в радиочестотната лента или ленти, в която или които работи радиосъоръжението.: 9dBm
02_RED_ES_Spanish	
DECLARACIÓN UE DE CONFORMIDAD SIMPLIFICADA	Por la presente, [Shanghai Kostal-Huayang Automotive Electric Co., Ltd.] declara que el tipo de equipo radioeléctrico [EV Remote K9499-002] es conforme con la Directiva 2014/53/UE. El texto completo de la declaración UE de conformidad está disponible en la dirección Internet siguiente: http://www.mitsubishi-motors.com/en/red-doc/ Banda o bandas de frecuencia en las que opera el equipo radioeléctrico: 802.11b 2.4G-2.4835GHz Potencia máxima de radiofrecuencia transmitida en la banda o bandas de frecuencia en las que opera el equipo radioeléctrico: 9dBm

03_RED_CS_Czech	
ZJEDNODUŠENÉ EU PROHLÁŠENÍ O SHODĚ	Tímto [Shanghai Kostal-Huayang Automotive Electric Co., Ltd.] prohlašuje, že typ rádiového zařízení [EV Remote K9499-002] je v souladu se směrnicí 2014/53/EU. Úplné znění EU prohlášení o shodě je k dispozici na této internetové adrese: http://www.mitsubishi-motors.com/en/red-doc/
	Kmitočtové pásmo (kmitočtová pásma), v němž (v nichž) rádiové zařízení pracuje: 802.11b 2.4G-2.4835GHz
	Maximální radiofrekvenční výkon vysílaný v kmitočtovém pásmu (v kmitočtových pásmech), v němž (v nichž) je rádiové zařízení provozováno: 9dBm
04_RED_DA_Danish	
FORENKLET EUOVERENSSTEMM ELSESERKLÆRI NG	Hermed erklærer [Shanghai Kostal-Huayang Automotive Electric Co., Ltd.], at radioudstyrstypen [EV Remote K9499-002] er i overensstemmelse med direktiv 2014/53/EU. EU-overensstemmelseserklæringens fulde tekst kan findes på følgende internetadresse: http://www.mitsubishi-motors.com/en/red-doc/
	Frekvensbånd, som radioudstyret fungerer på: 802.11b 2.4G-2.4835GHz
	Maksimal radiofrekvenseffekt, der udsendes i de frekvensbånd, som radioudstyret fungerer på: 9dBm
05_RED_DE_German	
VEREINFACHTE EUKONFORMITÄTS ERKLÄRUNG	Hiermit erkläre [Shanghai Kostal-Huayang Automotive Electric Co., Ltd.], dass der Funkanlagentyp [EV Remote K9499-002] der Richtlinie 2014/53/EU entspricht. Der vollständige Text der EU-Konformitätserklärung ist unter der folgenden Internetadresse verfügbar: http://www.mitsubishi-motors.com/en/red-doc/
	Das Frequenzband oder die Frequenzbänder, in dem bzw. denen die Funkanlage betrieben wird: 802.11b 2.4G-2.4835GHz
	Die in dem Frequenzband oder den Frequenzbändern, in dem bzw. denen die Funkanlage betrieben wird, abgestrahlte maximale Sendeleistung: 9dBm

06_RED_ET_Estonian	
LIHTSUSTATUD ELI	Käesolevaga deklareerib [Shanghai Kostal-Huayang Automotive Electric Co., Ltd.],
VASTAVUSDEKLARATSIOON	et käesolev raadioseadme tüüp [EV Remote K9499-002] vastab direktiivi 2014/53/EL nõuetele.
	ELI vastavusdeklaratsiooni täielik tekst on kätesaadav järgmisel internetiaadressil: http://www.mitsubishi-motors.com/en/red-doc/
	Sagedusribat(d), mille raadioseade töötab: 802.11b 2.4G-2.4835GHz
	Raadioseadme tööseadus(t)el edastatav maksimaalne saatetõhusus: 9dBm
07_RED_EL_Greek	
ΑΠΛΟΣΤΕΥΜΕΝΗ ΔΗΛΩΣΗ ΣΥΜΜΟΡΦΩΣΗΣ ΕΕ	Με την παρούσα ο/η [Shanghai Kostal-Huayang Automotive Electric Co., Ltd.], δηλώνει ότι ο ραδιοεξοπλισμός [EV Remote K9499-002] πληροί την οδηγία 2014/53/ΕΕ.
	Το πλήρες κείμενο της δήλωσης συμμόρφωσης ΕΕ διατίθεται στην ακόλουθη ιστοσελίδα στο διαδίκτυο: http://www.mitsubishi-motors.com/en/red-doc/
	Οι ζώνες συχνοτήτων στις οποίες λειτουργεί ο ραδιοεξοπλισμός: 802.11b 2.4G-2.4835GHz
	η μέγιστη ραδιοηλεκτρική ισχύς στις ζώνες συχνοτήτων στις οποίες λειτουργεί ο ραδιοεξοπλισμός: 9dBm
08_RED_EN_English	
SIMPLIFIED EU DECLARATION OF CONFORMITY	Hereby, [Shanghai Kostal-Huayang Automotive Electric Co., Ltd.] declares that the radio equipment type [EV Remote K9499-002] is in compliance with Directive 2014/53/EU.
	The full text of the EU declaration of conformity is available at the following internet address: http://www.mitsubishi-motors.com/en/red-doc/
	Frequency band(s) in which the radio equipment operates: 802.11b 2.4G-2.4835GHz
	Maximum radio-frequency power transmitted in the frequency band(s) in which the radio equipment operates: 9dBm

09_RED_FR_French	
DECLARATION UE	Le soussigné, [Shanghai Kostal-Huayang Automotive Electric Co., Ltd.], déclare que l'équipement radioélectrique du type [EV Remote K9499-002] est conforme à la directive 2014/53/UE.
DE CONFORMITE SIMPLIFIEE	Le texte complet de la déclaration UE de conformité est disponible à l'adresse internet suivante: http://www.mitsubishi-motors.com/en/red-doc/
	Bandes de fréquences utilisées par l'équipement radioélectrique: 802.11b 2.4G-2.4835GHz
	Puissance de radiofréquence maximale transmise sur les bandes de fréquences utilisées par l'équipement radioélectrique: 9dBm
10_RED_HR_Croatian	
POJEDNOSTAVLJE	[Shanghai Kostal-Huayang Automotive Electric Co., Ltd.] ovime izjavljuje da je radijska oprema tipa [EV Remote K9499-002] u skladu s Direktivom 2014/53/EU.
NA EU IZJAVA O SUKLADNOSTI	Cjeloviti tekst EU izjave o sukladnosti dostupan je na sljedećoj internetskoj adresi: http://www.mitsubishi-motors.com/en/red-doc/
	Frekvencijski pojas (frekvencijski pojasi) u kojem (kojima) radijska oprema radi: 802.11b 2.4G-2.4835GHz
	Najveća radiofrekvencijska snaga koja se prenosi u frekvencijskom pojasu (frekvencijskim pojasi) u kojem (kojima) radijska oprema radi: 9dBm
11_RED_IT_Italian	
DICHIARAZIONE DI CONFORMITÀ UE SEMPLIFICATA	Il fabbricante, [Shanghai Kostal-Huayang Automotive Electric Co., Ltd.], dichiara che il tipo di apparecchiatura radio [EV Remote K9499-002] è conforme alla direttiva 2014/53/UE.
	Il testo completo della dichiarazione di conformità UE è disponibile al seguente indirizzo Internet: http://www.mitsubishi-motors.com/en/red-doc/
	Bande di frequenza di funzionamento dell'apparecchiatura radio: 802.11b 2.4G-2.4835GHz
	Massima potenza a radiofrequenza trasmessa nelle bande di frequenza in cui opera l'apparecchiatura radio: 9dBm

12_RED_LV_Latvian	
VIENKĀRŠOTA ES ATBILSTĪBAS DEKLARĀCIJA	Ar šo [Shanghai Kostal-Huayang Automotive Electric Co., Ltd.] deklarē, ka radioiekārta [EV Remote K9499-002] atbilst Direktīvai 2014/53/ES. Plāns ES atbilstības deklarācijas teksts ir pieejams šādā interneta vietnē: http://www.mitsubishi-motors.com/en/red-doc/
	Frekvencu joslu(-as), kurā(-ās) radioiekārta darbojas: 802.11b 2.4G-2.4835GHz
	Frekvencu joslā(-ās), kurā(-ās) darbojas radioiekārta, maksimālo pārraidītā signāla jaudu: 9dBm
13_RED_LT_Lithuanian	
SUPAPRĀSTĪNĀTA ES ATBILSTĪBAS DEKLARĀCIJA	Aš, [Shanghai Kostal-Huayang Automotive Electric Co., Ltd.], patvirtinu, ka radioiekārta ir atbilstīga tipam [EV Remote K9499-002] atbilstīgi Direktīvai 2014/53/ES. Visas ES atbilstības deklarācijas tekstus ir pieejamas šiuo interneta adresu: http://www.mitsubishi-motors.com/en/red-doc/
	Dažņu josla (-os), kurā(-ose) veiktā radioiekārta ir atbilstīga: 802.11b 2.4G-2.4835GHz
	Didžiausia radio dažņu jauda, perduodama toje (tose) dažņu juostoje (-ose), kurā(-ose) veiktā radioiekārta ir atbilstīga: 9dBm
14_RED_HU_Hungarian	
EGYSZERŰSÍTETT EU-MEGFELELELŐSÉG NYILATKOZAT	[Shanghai Kostal-Huayang Automotive Electric Co., Ltd.] igazolja, hogy a [EV Remote K9499-002] típusú rádióberendezés megfelel a 2014/53/EU irányelvnek. Az EU-megfelelőségi nyilatkozat teljes szövege elérhető a következő internetes címen: http://www.mitsubishi-motors.com/en/red-doc/
	Az(ok) a frekvenciasáv(ok), amely(ek)en a rádióberendezés működik: 802.11b 2.4G-2.4835GHz
	Az abban a frekvenciasávban vagy azokban a frekvenciasávokban továbbított maximális teljesítmény, amely(ek)ben a rádióberendezés üzemel: 9dBm

15_RED_MT_Maltese	
DIKJARAZZJONI	B'dan, [Shanghai Kostal-Huayang Automotive Electric Co., Ltd.], niddikjara li dan
SSIMPLIFIKATA TA'	it-tip ta' tagħmir tar-radju [EV Remote K9499-002] huwa konformi mad-Direttiva
KONFORMITÀ	2014/53/UE.
TAL-UE	It-test kollu tad-dikjarazzjoni ta' konformità tal-UE huwa disponibbli f'dan l-indirizz tal-Internet li ġej: http://www.mitsubishi-motors.com/en/red-doc/
	Il-medda/meded tal-frekwenza li jaħdem fihom it-tagħmir tar-radju: 802.11b 2.4G-2.4835GHz
	Il-potenza massima tal-frekwenza tar-radju trazzmessa fil-medda/meded tal-frekwenza li jaħdem fihom it-tagħmir tar- radju: 9dBm
16_RED_NL_Dutch	
VEREENVOUDIGDE	Hierbij verklaar ik, [Shanghai Kostal-Huayang Automotive Electric Co., Ltd.], dat het
EUCONFORMITEITS	type radioapparaat [EV Remote K9499-002] conform is met Richtlijn 2014/53/EU.
VERKLARING	De volledige tekst van de EU-conformiteitsverklaring kan worden geraadpleegd op het volgende internetadres: http://www.mitsubishi-motors.com/en/red-doc/
	Frequentieband(en) waarin de radioapparatuur functioneert: 802.11b 2.4G-2.4835GHz
	Maximaal radiofrequent vermogen uitgezonden in de frequentieband(en) waarin de radioapparatuur functioneert: 9dBm
17_RED_PL_Polish	
UPROSZCZONA	[Shanghai Kostal-Huayang Automotive Electric Co., Ltd.] niniejszym oświadczam, że
DEKLARACJA	typ urządzenia radiowego [EV Remote K9499-002] jest zgodny z dyrektywą
ZGODNOŚCI UE	2014/53/UE. Pełny tekst deklaracji zgodności UE jest dostępny pod następującym adresem internetowym: http://www.mitsubishi-motors.com/en/red-doc/
	Zakresu(-ów) częstotliwości, w którym (których) pracuje urządzenie radiowe: 802.11b 2.4G-2.4835GHz
	Maksymalnej mocy częstotliwości radiowej emitowanej w zakresie(-ach) częstotliwości, w którym (których) pracuje urządzenie radiowe: 9dBm

18_RED_PT_Portuguese	
DECLARAÇÃO UE DE CONFORMIDADE SIMPLIFICADA	O(a) abaixo assinado(a) [Shanghai Kostal-Huayang Automotive Electric Co., Ltd.] declara que o presente tipo de equipamento de radio [EV Remote K9499-002] está em conformidade com a Diretiva 2014/53/UE. O texto integral da declaração de conformidade está disponível no seguinte endereço de internet: http://www.mitsubishi-motors.com/en/red-doc/ A(s) banda(s) de frequências em que o equipamento de rádio funciona: 802.11b 2.4G-2.4835GHz A potência máxima de radiofrequências transmitida na(s) banda(s) de frequências em que o equipamento de rádio funciona: 9dBm
19_RED_RO_Romanian	
DECLARAȚIA UE DE CONFORMITATE SIMPLIFICATĂ	Prin prezenta, [Shanghai Kostal-Huayang Automotive Electric Co., Ltd.] declară că tipul de echipamente radio [EV Remote K9499-002] este în conformitate cu Directiva 2014/53/UE. Textul integral al declarației UE de conformitate este disponibil la următoarea adresă internet: http://www.mitsubishi-motors.com/en/red-doc/ Banda (benzile) de frecvențe în care funcționează echipamentul radio: 802.11b 2.4G-2.4835GHz Puterea maximă de radiofrecvență transmisă în banda (benzile) de frecvențe în care funcționează echipamentul radio: 9dBm
20_RED_SK_Slovak	
ZJEDNODUŠENÉ EÚ VYHLÁSENIE O ZHODE	[Shanghai Kostal-Huayang Automotive Electric Co., Ltd.] týmto vyhlasuje, že rádiové zariadenie typu [EV Remote K9499-002] je v súlade so smernicou 2014/53/EÚ. Úplné EÚ vyhlásenie o zhode je k dispozícii na tejto internetovej adrese: http://www.mitsubishi-motors.com/en/red-doc/ Frekvencné pásmo resp. pásma, v ktorých rádiové zariadenie pracuje: 802.11b 2.4G-2.4835GHz Maximálny vysokofrekvenčný výkon prenášaný vo frekvencnom pásme, resp. pásmach, v ktorých rádiové zariadenie pracuje: 9dBm

21_RED_SL_Slovenian	
POENOSTAVLJENA	[Shanghai Kostal-Huayang Automotive Electric Co., Ltd.] potrjuje, da je tip radijske opreme [EV Remote K9499-002] skladen z Direktivo 2014/53/EU.
IZJAVA EU O SKLADNOSTI	Celotno besedilo izjave EU o skladnosti je na voljo na naslednjem spletnem naslovu: http://www.mitsubishi-motors.com/en/red-doc/
	Frekvenčni pas ali pasovi, na katerih deluje radijska oprema: 802.11b 2.4G-2.4835GHZ
	Največja energija za radijsko frekvenco, preneseno po frekvenčnem pasu ali pasovih, na katerih radijska oprema deluje: 9dBm
22_RED_FL_Finnish	
YKSINKERTAISTETT	[Shanghai Kostal-Huayang Automotive Electric Co., Ltd.] vakuuttaa, että radiolaitetyyppi [EV Remote K9499-002] on direktiivin 2014/53/EU mukainen.
U	EU-vaatimustenmukaisuusvakuutuksen täysimittainen teksti on saatavilla seuraavassa internetosoitteessa: http://www.mitsubishi-motors.com/en/red-doc/
EUVAAATIMUSTENMIUKAISUUSVAKUUTUS	
US	Radiolaitteet, joilla radiolaitte toimii: 802.11b 2.4G-2.4835GHZ
	Suurin mahdollinen lähetysteho radiolaitteilla, joilla radiolaitte toimii: 9dBm
23_RED_SV_Swedish	
FÖRENKLAD	Härmed försäkrar [Shanghai Kostal-Huayang Automotive Electric Co., Ltd.] att denna typ av radioutrustning [EV Remote K9499-002] överensstämmer med direktiv 2014/53/EU.
EUFÖRSÄKRAN	Den fullständiga texten till EU-försäkran om överensstämmelse finns på följande webbadress: http://www.mitsubishi-motors.com/en/red-doc/
OM ÖVERENSSTÄMMELSE	
SE	Det eller de frekvensband där radioutrustningen arbetar: 802.11b 2.4G-2.4835GHZ
	Den maximala radiofrekvenseffekt som överförs inom det eller de frekvensband där radioutrustningen arbetar: 9dBm

24_RED_IS_Icelandic	
EINFÖLDUÐ	Hér, [Shanghai Kostal-Huayang Automotive Electric Co., Ltd.], segir að [EV Remote K9499-002] eru í samræmi við tilskipun 2014/53/ESB.
ESB-SAMRÆMISY	Fyrir upplýsingar, vinsamlegast aðgang eftirfarandi vefsíðu: http://www.mitsubishi-motors.com/en/red-doc/
FIRLÝSING	Tíðnisviði (s): sem þráðlausan búnað undirrita burt : 802.11b 2.4G-2.4835GHz
	Mámarks útlátið-tíðni miðlað á tíðnisviðinu (s) sem þráðlausan búnað undirrita burt: 9dBm
25_RED_NO_Norwegian	
FORENKLET EU	Herved [Shanghai Kostal-Huayang Automotive Electric Co., Ltd.], erklærer at [EV K9499-002] er i samsvar med direktiv 2014/53/EU.
KONFORMITETSE	For flere detaljer, vennligst følgende URL: http://www.mitsubishi-motors.com/en/red-doc/
RKLÆRING	Frekvens bånd (s) der radioutstyret fungerer : 802.11b 2.4G-2.4835GHz
	Maksimal radiofrekvensen strøm ble sendt i frekvensbånd(s) som radioutstyret fungerer: 9dBm
26_RED_TR_Turkish	
AB UYGUNLUK	Burada, [Shanghai Kostal-Huayang Automotive Electric Co., Ltd.], [EV Remote K9499-002] in 2014/53/AB sayılı Direktife uygun olduğunu beyan eder.
BASITLEŞTİRİLMİ	Ayrıntılar için lütfen aşağıdaki URL'ye erişin: http://www.mitsubishi-motors.com/en/red-doc/
Ş BEYAN	Radyo ekipmanının çalıştığı frekans bantları : 802.11b 2.4G-2.4835GHz
	Radyo ekipmanının çalıştığı frekans bantlarında iletilen maksimum radyofrekans gücü: 9dBm

27_RED_MK_Macedonian	
ПОЕДНОСТАВЕН А ДЕКЛАРАЦИЈА ЗА СОГЛАСНОСТ НА ЕУ	Со ова, [Shanghai Kostal-Huayang Automotive Electric Co., Ltd.], изјавува дека [EV Remote K9499-002] се во согласност со Директивата 2014/53/EU. За повеќе детали, посетете ја следната веб-адреса: http://www.mitsubishi-motors.com/en/red-doc/ Радио опремата работи на следниот радиофреквенциски спектар : 802.11b 2.4G-2.4835GHz Радио опремата функционира на следната максимална моќност на радио фреквенции емитирана во радиофреквенцискиот спектар: 9dBm
28_RED_SQ_Albanian	
DEKLARATË THJESHTUAR SË KONFORMITETIT TË BE-SË	Me anë të kësaj, [Shanghai Kostal-Huayang Automotive Electric Co., Ltd.], deklaron se [EV Remote K9499-002] janë në përputhje me Direktivën 2014/53/BE. Për detaje, vizitoni URL e mëposhtme: http://www.mitsubishi-motors.com/en/red-doc/ Banda(t) e frekuencës me të cilat punojnë pajisjet radio : 802.11b 2.4G-2.4835GHz Fuqija maksimale radio-frekuencë e transmetuar në bandën(at) e frekuencave në të cilën punojnë pajisjet radio: 9dBm
29_RED_XX_Montenegrin	
POJEDNOSTAVLJ ENA EU IZJAVA O USAGLAŠENOSTI	Ovim putem [Shanghai Kostal-Huayang Automotive Electric Co., Ltd.], izjavljuje da je [EV Remote K9499-002] su u skladu sa Direktivi 2014/53/EU. Za detalje, molimo vas da pristupite slijedeći URL: http://www.mitsubishi-motors.com/en/red-doc/ Frekventni opseg u kojem funkcioniše radio oprema : 802.11b 2.4G-2.4835GHz Maksimalna prenesena snaga radio frekvencije u frekventnom opsegu u kojem funkcioniše radio oprema: 9dBm

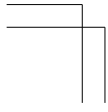
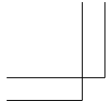

14- 50 Declaration of Conformity

30_RED_KA_Georgian	
EU	ამასთან, [Shanghai Kostal-Huayang Automotive Electric Co., Ltd.], შპს, აცხადებს, რომ [EV Remote K9499-002] შესაზამისობაში დირექტოვა 2014/53/EU.
გამარტეგებული შესაზამისობის განცხადების	დამატებითი ინფორმაციისათვის, გთხოვთ, იხილოთ შემდეგი URL: http://www.mitsubishi-motors.com/en/red-doc/
	სიხშირეს ტალღები, რომლებზეც მუშაობს რადიო : 802.11b 2.4G-2.4835GHZ
	რადიო მოწყობის რადიო-სიხშირის მაქსიმალური სიმძლავრე: 9dBm



OGGE19E1

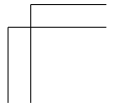
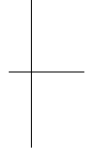
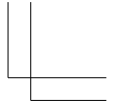

A) Generic information:

Manufacturer Postal Address

JVCケンウッド株式会社
3-12 Moriya-cho, Kanagawa-ku, Yokohama-shi, Kanagawa, 221-0022, JAPAN

EU Representative

JVCケンウッド Europe B.V.
Amstordamsingel 37, 1422 AC UITHOORN, THE NETHERLANDS

B) Language Text:

01_RED_BG_Bulgarian	С настоящото JVCケンウッド Corporation, декларира, че MXLO15ELG4 са в съответствие с Директива 2014/53/ЕС. За повече информация, моля, посетете следния URL адрес: http://www.mitsubishi-motors.com/en/red-doc/
	радиочестотната лента или ленти, в която или които работи радиосъоръжението: 2.402 GHz to 2.480 GHz
	максималната радиочестотна мощност, излъчвана в радиочестотната лента или ленти, в която или които работи радиосъоръжението.: +1dBm±1dB Power Class 2
02_RED_ES_Spanish	Por este medio, JVCケンウッド Corporation, declara que MXLO15ELG4 están en conformidad con la Directiva 2014/53/UE. Para obtener más detalles, acceda a la siguiente URL: http://www.mitsubishi-motors.com/en/red-doc/
DECLARACIÓN UE DE CONFORMIDAD SIMPLIFICADA	Banda o bandas de frecuencia en las que opera el equipo radioeléctrico: 2.402 GHz to 2.480 GHz
	Potencia máxima de radiofrecuencia transmitida en la banda o bandas de frecuencia en las que opera el equipo radioeléctrico: +1dBm±1dB Power Class 2

03_RED_CS_Czech	
JEDNODUŠENÉ EU PROHLÁŠENÍ O SHODĚ	<p>Tímto JVCENWOOD Corporation, prohlašuje, že MXLO15ELG4 jsou v souladu se směrnicí 2014/53/EU. Podrobnosti naleznete na následující internetové adrese: http://www.mitsubishi-motors.com/en/red-doc/</p> <p>Kmitočtové pásmo (kmitočtová pásma), v němž (v nichž) rádiové zařízení pracuje: 2.402 GHz to 2.480 GHz</p> <p>Maximální radiofrekvenční výkon vysílaný v kmitočtovém pásmu (v kmitočtových pásmech), v němž (v nichž) je rádiové zařízení provozováno: +1dBm±1dB Power Class 2</p>
04_RED_DA_Danish	
FORENKLET EUOVERENSSTEMM ELSEERKLÆRING	<p>Herved, JVCENWOOD Corporation, erklærer, at MXLO15ELG4 er i overensstemmelse med direktiv 2014/53/EU. For yderligere information gå ind på følgende webadresse: http://www.mitsubishi-motors.com/en/red-doc/</p> <p>Frekvensbånd, som radioudstyret fungerer på: 2.402 GHz to 2.480 GHz</p> <p>Maksimal radiofrekvensseffekt, der udsendes i de frekvensbånd, som radioudstyret fungerer på: +1dBm±1dB Power Class 2</p>
05_RED_DE_German	
VEREINFACHTE EUKONFORMITÄTSERKLÄRUNG	<p>Hiermit erklärt JVCENWOOD Corporation, dass MXLO15ELG4 in Übereinstimmung mit der Richtlinie 2014/53/EU stehen. Weitere Informationen erhalten Sie über folgende URL: http://www.mitsubishi-motors.com/en/red-doc/</p> <p>Das Frequenzband oder die Frequenzbänder, in dem bzw. denen die Funkanlage betrieben wird: 2.402 GHz to 2.480 GHz</p> <p>Die in dem Frequenzband oder den Frequenzbändern, in dem bzw. denen die Funkanlage betrieben wird, abgestrahlte maximale Sendeleistung: +1dBm±1dB Power Class 2</p>
06_RED_ET_Estonian	

LIHTUSTATUD ELI VASTAVUSDEKLARATSIOON	Käesolevaga JVCENWOOD Corporation, teatab, et MXLO15ELG4 on kooskõlas direktiivi 2014/53/EL. Üksikasjalikuma teabe saamiseks tutvuda järgmistel URL: http://www.mitsubishi-motors.com/en/red-doc/
	Sagedusriba(d), millel raadioseade töötab: 2.402 GHz to 2.480 GHz
	Raadioseadme töösagedus(t)el edastatav maksimaalne saatevõimsus: +1dBm±1dB Power Class 2
07_RED_EL_Greek	
ΑΠΛΟΥΣΤΕΥΜΕΝΗ ΔΗΛΩΣΗ ΣΥΜΜΟΡΦΟΣΗΣ ΕΕ	Δια του παρόντος, JVCENWOOD Corporation, δηλώνει ότι MXLO15ELG4 είναι σε συμμόρφωση με την οδηγία 2014/53/ΕΕ. Για λεπτομέρειες, επισκεφθείτε την παρακάτω διεύθυνση URL: http://www.mitsubishi-motors.com/en/red-doc/
	Οι ζώνες συχνοτήτων στις οποίες λειτουργεί ο ραδιοεξοπλισμός: 2.402 GHz to 2.480 GHz
	Η μέγιστη ραδιοηλεκτρική ισχύς στις ζώνες συχνοτήτων στις οποίες λειτουργεί ο ραδιοεξοπλισμός: +1dBm±1dB Power Class 2
08_RED_EN_English	
SIMPLIFIED EU DECLARATION OF CONFORMITY	Hereby, JVCENWOOD Corporation, declares that MXLO15ELG4 are in compliance with Directive 2014/53/EU. For details, please access the following URL: http://www.mitsubishi-motors.com/en/red-doc/
	Frequency band(s) in which the radio equipment operates: 2.402 GHz to 2.480 GHz
	Maximum radio-frequency power transmitted in the frequency band(s) in which the radio equipment operates: +1dBm±1dB Power Class 2
09_RED_FR_French	
DECLARATION UE DE CONFORMITE SIMPLIFIEE	Par la présente, JVCENWOOD Corporation, déclare que MXLO15ELG4 sont conformes à la directive 2014/53/UE. Pour plus de détails, veuillez accéder à l'URL suivante: http://www.mitsubishi-motors.com/en/red-doc/
	Bandes de fréquences utilisées par l'équipement

	radioélectrique: 2.402 GHz to 2.480 GHz Puissance de radiofréquence maximale transmise sur les bandes de fréquences utilisées par l'équipement radioélectrique: +1dBm±1dB Power Class 2
10_RED_IS_Icelandic	
EIFÖLDIÐ ESB-SAMRÆMISYFIRLÝSING	Hér, JVCKENWOOD Corporation, segir að MXI O15FI G4 emu i samræmi við tilskipun 2014/53/ESB. Fyrir upplýsingar, vinsamlegast aðgang eftirfarandi vefsíðu: http://www.mitsubishi-motors.com/en/red-doc/
	Tíðnisviði (s) sem þröðlausan búnað undirrita burt : 2.402 GHz to 2.480 GHz
	Mámarks útvarp-tíðni máttur miðlað á tíðnisviðinu (s) sem þröðlausan búnað undirrita burt: +1dBm±1dB Power Class 2
11_RED_HR_Croatian	
POJEDNOSTAVLJENA EU IZJAVA O SUKLADNOSTI	Ovime JVCKENWOOD Corporation, izjavljije da je MXLO15ELG4 su u skladu s Direktivom 2014/53/EU. Za detalje, molimo pogledajte sljedeći URL: http://www.mitsubishi-motors.com/en/red-doc/
	Frekvencijski pojas (frekvencijski pojasi) u kojem (kojima) radijska oprema radi: 2.402 GHz to 2.480 GHz
	Najveća radiofrekvencijska snaga koja se prenosi u frekvencijskom pojasu (frekvencijskim pojasi) u kojem (kojima) radijska oprema radi: +1dBm±1dB Power Class 2
12_RED_IT_Italian	
DICHIARAZIONE DI CONFORMITÀ UE SEMPLIFICATA	Con la presente, JVCKENWOOD Corporation, dichiara che MXLO15ELG4 sono in conformità con la direttiva 2014/53/UE. Per ulteriori informazioni, si prega di consultare il seguente URL: http://www.mitsubishi-motors.com/en/red-doc/
	Bande di frequenza di funzionamento dell'apparecchiatura radio: 2.402 GHz to 2.480 GHz
	Massima potenza a radiofrequenza trasmessa nelle bande di

	<p>frekvenca in cui opera l'apparecchiatura radio: +1dBm±1dB Power Class 2</p>
13_RED_LV_Latvian	
VIENKĀRŠOTA ES ATBILSTĪBAS DEKLARĀCIJA	<p>Ar šo JVCKENWOOD Corporation, pazīmo, ka MXLO15ELG4 ir saskaņā ar Direktīvu 2014/53/ES. Lai iegūtu plašāku informāciju, lūdzu, apmeklējiet šādu URL: http://www.mitsubishi-motors.com/en/red-doc/</p> <p>Frekvenču joslā(-ās), kurā(-ās) radnieciskārtas darbojas: 2.402 GHz to 2.480 GHz</p> <p>Frekvenču joslā(-ās), kurā(-ās) darbojas radioiekārtas, maksimālo pārraidītā signāla jaudu.: +1dBm±1dB Power Class 2</p>
14_RED_LT_Lithuanian	
SUPAPRASTINTA ES ATITIKTIES DEKLARACIJA	<p>Šiuo JVCKENWOOD Corporation, pareiškiu, kad MXLO15ELG4 yra laikomasi Direktivos 2014/53/ES. Del išsamesnės informacijos, prašome prisijungti prie šių URL: http://www.mitsubishi-motors.com/en/red-doc/</p> <p>Dažnių juosta (-os), kurioje (-iose) veikia radijo įrenginiai: 2.402 GHz to 2.480 GHz</p> <p>Didžiausia radijo dažnių galia, perduodama toje (tose) dažnių juostoje (-ose), kurioje (-iose) veikia radijo įrenginiai: +1dBm±1dB Power Class 2</p>
15_RED_HU_Hungarian	
EGYSZERŰSÍTETT EUMEGFELELŐSÉGI NYILATKOZAT	<p>Ezáltal JVCKENWOOD Corporation, kijelenti, hogy MXLO15ELG4 irányelvnek megfelelő 2014/53/EU A részleteket lásd az alábbi URL:http://www.mitsubishi-motors.com/en/red-doc/</p> <p>Az(ok) a frekvenciasáv(ok), amely(ek)en a rádióberendezés működik: 2.402 GHz to 2.480 GHz</p> <p>Az abban a frekvenciasávban vagy azokban a frekvenciasávokban továbbított frekvenciasávokban maximális jelerősség, amely(ek)ben a rádióberendezés üzemel: +1dBm±1dB Power Class 2</p>
16_RED_MT_Maltese	

DIKJARAZZJONI SSIMPLIFIKATA TA' KONFORMITÀ TAL-UE	<p>Hawnhekk, JVCKENWOOD Corporation, jiddikjara li MXL015ELG4 huma konformi mad-Direttiva 2014/53/UE. Ghad-dettalji, jekk jogħġbok access għall-URL li ġej: http://www.mitsubishi-motors.com/en/red-doc/</p> <p>Li-medda/meded tal-frekwenza li jahdem fihom it-tagħmir tar-radju: 2.402 GHz to 2.480 GHz</p> <p>Li-potenza massima tal-frekwenza tar-radju trazzmessa fil-medda/meded tal-frekwenza li jahdem fihom it-tagħmir tar-radju: +1dBm±1dB Power Class 2</p>
17_RED_NL_Dutch	
VEREENVOUDIGDE EUCONFORMITEITSVERKLARING	<p>Hierbij JVCKENWOOD Corporation, verklaart dat MXL015ELG4 zijn in overeenstemming met Richtlijn 2014/53/EU. Voor meer informatie, neem dan de volgende URL: http://www.mitsubishi-motors.com/en/red-doc/</p> <p>Frequentieband(en) waarin de radioapparatuur functioneert: 2.402 GHz to 2.480 GHz</p> <p>Maximaal radiofrequent vermogen uitgezonden in de frequentieband(en) waarin de radioapparatuur functioneert: +1dBm±1dB Power Class 2</p>
18_RED_PL_Polish	
UPROSZCZONA DEKLARACJA ZGODNOŚCI UE	<p>Niniejszym JVCKENWOOD Corporation, deklaruje, że MXL015ELG4 są zgodne z dyrektywą 2014/53/UE. Szczegółowe informacje można znaleźć pod następującym adresem URL: http://www.mitsubishi-motors.com/en/red-doc/</p> <p>Zakres(-ów) częstotliwości, w którym (których) pracuje urządzenie radiowe: 2.402 GHz to 2.480 GHz</p> <p>Maksymalnej mocy częstotliwości radiowej emitowanej w zakresie(-ach) częstotliwość, w którym (których) pracuje urządzenie radiowe: +1dBm±1dB Power Class 2</p>
19_RED_PT_Portuguese	
DECLARAÇÃO UE DE CONFORMIDADE SIMPLIFICADA	<p>Por este meio, a JVCKENWOOD Corporation, declara que MXL015ELG4 estão em conformidade com a Directiva 2014/53/UE. Para obter detalhes, acesse o seguinte URL:</p>

	http://www.mitsubishi-motors.com/en/red-doc/
A(s) banda(s) de frecuenas em que o equipamento de rdio funciona:	2.402 GHz to 2.480 GHz
A potncia mxima de radiofrecuenas transmitida na(s) banda(s) de frecuenas em que o equipamento de rdio funciona:	+1dBm1dB Power Class 2
20_RED_RO_Romanian	
DECLARATIA UE DE CONFORMITATE SIMPLIFICAT	Prin prezenta, JVCENWOOD Corporation, declar c MXLO15ELG4 sunt conforme cu Directiva 2014/53/UE. Pentru mai multe detalii, v rugm s accesa urmtoarea adres URL: http://www.mitsubishi-motors.com/en/red-doc/
Banda (benzile) de frecvene n care funcioneaz echipamentul radio:	2.402 GHz to 2.480 GHz
Puterea maxim de radiofrecven transmis n banda (benzile) de frecvene n care funcioneaz echipamentul radio:	+1dBm1dB Power Class 2
21_RED_SK_Slovak	
ZJEDNODUŠEN EU VYHLSENIE O ZHODE	Tmto JVCENWOOD Corporation, vyhlasuje, e MXLO15ELG4 s v slade so smernicou 2014/53/EU. Podrobnosti njdete na nasledujcej internetovej adrese: http://www.mitsubishi-motors.com/en/red-doc/
Frekvenn psma resp. psma, v ktorch rdiovej zariadenie pracuje:	2.402 GHz to 2.480 GHz
Maximlny vysokofrekvenn výkon prensan vo frekvennom psmach, resp. psmach, v ktorch rdiovej zariadenie pracuje:	+1dBm1dB Power Class 2
22_RED_SL_Slovenian	
POENOSTAVLJENA IZJAVA EU O SKLADNOSTI	S tem, JVCENWOOD Corporation, izjavlja, da so MXLO15ELG4 v skladi z Direktivo 2014/53/EU. Za ve informacij, prosimo, pojdite na naslednji naslov: http://www.mitsubishi-motors.com/en/red-doc/
Frekvenni pas ali pasovi, na katerih deluje radijska oprema:	

	2.402 GHz to 2.480 GHz
	Največja energija za radijsko frekvenco, preneseno po frekvenčnem pasu ali pasovih, na katerih radijska oprema deluje: +1dBm±1dB Power Class 2
23_RED_FL_Finnish	
YKSINKERTAISTETTU EUVAATIMUSTENMUKAISUUSVAKUUTUS	Täten JVCKENWOOD Corporation, ilmoittaa, että MXLO15ELG4 noudattaa direktiivin 2014/53/EU liisälietoja seuraavassa URL-osoitteessa: http://www.mitsubishi-motors.com/en/red-doc/
	Radiotaaajuudet, jolla radiolaitte toimii: 2.402 GHz to 2.480 GHz
	Suurin mahdollinen lähetysteho radiotaaajuuksilla, jolla radiolaitte toimii: +1dBm±1dB Power Class 2
24_RED_SV_Swedish	
FÖRENKLAD EUFÖRSÄKRAN OM ÖVERENSSTÄMMELSE	Härmed JVCKENWOOD Corporation, förklarar att MXLO15ELG4 överensstämmer med direktiv 2014/53/EU. För mer information, gå in på följande webbadress: http://www.mitsubishi-motors.com/en/red-doc/ Det eller de frekvensband där radioutrustningen arbetar: 2.402 GHz to 2.480 GHz Den maximala radiofrekvensseffekt som överförs inom det eller de frekvensband där radioutrustningen arbetar: +1dBm±1dB Power Class 2
25_RED_NO_Norwegian	
FORENKLET EU KONFORMITETSERKLÆRING	Herved JVCKENWOOD Corporation, erklærer at MXLO15ELG4 er i samsvar med direktiv 2014/53/EU. For flere detaljer, vennligst følgende URL: http://www.mitsubishi-motors.com/en/red-doc/ Frekvens bånd (s) der radioustyret fungerer: 2.402 GHz to 2.480 GHz Maksimal radiofrekvensen strøm ble sendt i frekvensbånd(s) som radioustyret fungerer: +1dBm±1dB Power Class 2
26_RED_TR_Turkish	
AB UYGUNLUK BASITLESİTİRLİMİŞ	Burada, JVCKENWOOD Corporation, MXLO15ELG4 in 2014/53/AB

BEYAN	sayılı Direktife uygun olduğunu beyan eder. Ayrıntılar için lütfen aşağıdaki URL'ye erişin: http://www.mitsubishi-motors.com/en/red-doc/
	Radio ekipmanının çalıştığı frekans bantları: 2.402 GHz to 2.480 GHz
	Radio ekipmanının çalıştığı frekans bantlarında iletilen maksimum radyofrekans gücü: $+1\text{dBm} \pm 1\text{dB}$ Power Class 2
27_RED_MK_Macedonian	
ПОЕДНОСТАВЕНА ДЕКЛАРАЦИЈА ЗА СОГЛАСНОСТ НА ЕУ	Со ова, JVCENWOOD Corporation, изјавува дека MXLO15ELG4 се во согласност со Директивата 2014/53/EU. За повеќе детали, посетете ја следната веб-адреса: http://www.mitsubishi-motors.com/en/red-doc/
	Radio опремата работи на следниот радиофреквенциски спектар: 2.402 GHz to 2.480 GHz
	Radio опремата функционира на следната максимална моќност на радио фреквенции емитувана во радиофреквенцискиот спектар: $+1\text{dBm} \pm 1\text{dB}$ Power Class 2
28_RED_SQ_Albanian	
DEKLARATË THJESHTUAR SË KONFORMITETIT TË BE-SË	Me anë të kësaj, JVCENWOOD Corporation, deklaron se MXLO15ELG4 janë në përputhje me Direktivën 2014/53/BE. Për detaje, vizitoni URL e mëposhtme: http://www.mitsubishi-motors.com/en/red-doc/
	Banda(t) e frekuencës me të cilat punojnë pajisjet radio: 2.402 GHz to 2.480 GHz
	Fuqia maksimale radio-frekuencë e transmetuar në bandën(at) e frekuencave në të cilën punojnë pajisjet radio: $+1\text{dBm} \pm 1\text{dB}$ Power Class 2
29_RED_XX_Montenegritin	
POJEDNOSTAVLJENA EU IZJAVA O USAGLAŠENOSTI	Ovim putem, JVCENWOOD Corporation, izjavljuje da je MXLO15ELG4 su u skladu sa Direktivi 2014/53/EU. Za detalje, molimo vas da pristupite slijedeći URL: http://www.mitsubishi-motors.com/en/red-doc/
	Frekventni opseg u kojem funkcioniše radio oprema: 2.402 GHz to 2.480 GHz
	Maksimalna prenesena snaga radio frekvencije u frekventnom opsegu u kojem funkcioniše radio oprema: $+1\text{dBm} \pm 1\text{dB}$ Power Class 2

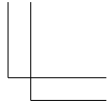
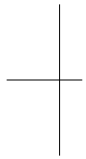
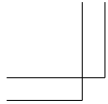

14- 60 Declaration of Conformity

30_RED_KA_Georgian	
EU გამართებული შესაბამისობის განცხადების	<p>ამასთან, JVCKENWOOD Corporation, შპს, აცხადებს, რომ MXLO15ELG4 შესაბამისობაშია დირექტივა 2014/53/EU. დამატებითი ინფორმაციისთვის, გთხოვთ, იხილოთ შემდეგი URL: http://www.mitsubishi-motors.com/entred.doc/</p> <p>სიხშირის ტალღები, რომლებზეც მუშაობს რადიო: 2,402 GHz to 2.480 GHz</p> <p>რადიო მოწყობილობის რადიო-სიხშირის მქსელურ სიმძლავრე: +1dBm ± 1dB Power Class 2</p>

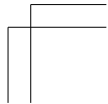
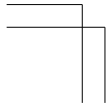

OGGE19E1

A) Generic information:**Manufacturer Postal Address**

Continental Automotive GmbH Seimensstrasse 12
D-93055 Regensburg Germany

B) Language Text:

01_RED_BG_Bulgarian	С настоящото Continental Automotive GmbH декларира, че този тип радиосъоръжение S180052094/TIS-03 е в съответствие с Директива 2014/53/ЕС. Цялостният текст на ЕС декларацията за съответствие може да се намери на следния интернет адрес: http://www.mitsubishi-motors.com/en/red-doc/
ОПРОСТЕНА ЕС ДЕКЛАРАЦИЯ ЗА СЪОТВЕТСТВИЕ	радиочестотната лента или ленти, в която или които работи радиосъоръжението: 433.92MHz максималната радиочестотна мощност, излъчвана в радиочестотната лента или ленти, в която или които работи радиосъоръжението.: -17 dBm
02_RED_ES_Spanish	
DECLARACIÓN UE DE CONFORMIDAD SIMPLIFICADA	Por la presente, Continental Automotive GmbH declara que el tipo de equipo radioeléctrico S180052094/TIS-03 es conforme con la Directiva 2014/53/UE. El texto completo de la declaración UE de conformidad está disponible en la dirección Internet siguiente: http://www.mitsubishi-motors.com/en/red-doc/ Banda o bandas de frecuencia en las que opera el equipo radioeléctrico: 433.92MHz Potencia máxima de radiofrecuencia transmitida en la banda o bandas de frecuencia en las que opera el equipo radioeléctrico: -17 dBm
03_RED_CS_Czech	
ZJEDNODUŠENÉ	Tímto Continental Automotive GmbH prohlašuje, že typ

EU PROHLÁŠENÍ O SHODĚ	rádiového zařízení S180052094/TIS-03 je v souladu se směrnici 2014/53/EU. Úplné znění EU prohlášení o shodě je k dispozici na této internetové adrese: http://www.mitsubishi-motors.com/en/red-doc/
	Kmitočtové pásmo (kmitočtová pásma), v němž (v nichž) rádiové zařízení pracuje: 433.92MHz
	Maximální radiofrekvenční výkon vysílaný v kmitočtovém pásmu (v kmitočtových pásmech), v němž (v nichž) je rádiové zařízení provozováno: -17 dBm
04_RED_DA_Danish	
FORENKLET EUOVERENSSTEMM ELSEERKLÆRI NG	Hermed erklærer Continental Automotive GmbH, at radioudstyrstypen S180052094/TIS-03 er i overensstemmelse med direktiv 2014/53/EU. EUoverensstemmelseserklæringens fulde tekst kan findes på følgende internetadresse: http://www.mitsubishi-motors.com/en/red-doc/
	Frekvensbånd, som radioudstyret fungerer på: 433.92MHz
	Maksimal radiofrekvenseffekt, der udsendes i de frekvensbånd, som radioudstyret fungerer på: -17 dBm
05_RED_DE_German	
VEREINFACHTE EUKONFORMITÄTSERKLÄRUNG	Hiermit erklärt Continental Automotive GmbH, dass der Funkanlagentyp S180052094/TIS-03 der Richtlinie 2014/53/EU entspricht. Der vollständige Text der EU-Konformitätserklärung ist unter der folgenden Internetadresse verfügbar: http://www.mitsubishi-motors.com/en/red-doc/
	Das Frequenzband oder die Frequenzbänder, in dem bzw. denen die Funkanlage betrieben wird: 433.92MHz
	Die in dem Frequenzband oder den Frequenzbändern, in dem bzw. denen die Funkanlage betrieben wird, abgestrahlte maximale Sendeleistung: -17 dBm
06_RED_ET_Estonian	

<p>LIHTSUSTATUD ELI VASTAVUSDEKLARATSIOON</p>	<p>Käesolevaga deklareerib Continental Automotive GmbH, et käesolev raadioseadme tüüp S180052094/TIS-03 vastab direktiivi 2014/53/EL nõuetele. ELi vastavusdeklaratsiooni täielik tekst on kättesaadav järgmisel internetiaadressil: http://www.mitsubishi-motors.com/en/red-doc/</p>
	<p>Sagedusriba(d), millel raadioseade töötab: 433.92MHz</p>
	<p>Raadioseadme töösagedus(i)el edastatav maksimaalne saatevõimsus: -17 dBm</p>
<p>07_RED_EL_Greek</p>	
<p>ΑΠΛΟΥΣΤΕΥΜΕΝΗ ΔΗΛΩΣΗ ΣΥΜΜΟΡΦΩΣΗΣ ΕΕ</p>	<p>Με την παρούσα ο/η Continental Automotive GmbH, δηλώνει ότι ο ραδιοεξοπλισμός S180052094/TIS-03 πληροί την οδηγία 2014/53/ΕΕ. Το πλήρες κείμενο της δήλωσης συμμόρφωσης ΕΕ διατίθεται στην ακόλουθη ιστοσελίδα στο διαδίκτυο: http://www.mitsubishi-motors.com/en/red-doc/</p>
	<p>Οι ζώνες συχνοτήτων στις οποίες λειτουργεί ο ραδιοεξοπλισμός: 433.92MHz</p>
	<p>η μέγιστη ραδιοηλεκτρική ισχύς στις ζώνες συχνοτήτων στις οποίες λειτουργεί ο ραδιοεξοπλισμός: -17 dBm</p>
<p>08_RED_EN_English</p>	
<p>SIMPLIFIED EU DECLARATION OF CONFORMITY</p>	<p>Hereby, Continental Automotive GmbH declares that the radio equipment type S180052094/TIS-03 is in compliance with Directive 2014/53/EU. The full text of the EU declaration of conformity is available at the following internet address: http://www.mitsubishi-motors.com/en/red-doc/</p>
	<p>Frequency band(s) in which the radio equipment operates: 433.92MHz</p>
	<p>Maximum radio-frequency power transmitted in the frequency band(s) in which the radio equipment operates: -17 dBm</p>
<p>09_RED_FR_French</p>	
<p>DECLARATION UE DE CONFORMITE</p>	<p>Le soussigné, Continental Automotive GmbH, déclare que l'équipement radioélectrique du type S180052094/TIS-03 est</p>

SIMPLIFIEE	conforme à la directive 2014/53/UE. Le texte complet de la déclaration UE de conformité est disponible à l'adresse internet suivante: http://www.mitsubishi-motors.com/en/red-doc/ Bandes de fréquences utilisées par l'équipement radioélectrique: 433.92MHz Puissance de radiofréquence maximale transmise sur les bandes de fréquences utilisées par l'équipement radioélectrique: -17 dBm
10_RED_GA_empty_no_text	
Related RED Directive not released.	
11_RED_HR_Croatian	
POJEDNOSTAVLJENA EU IZJAVA O SUKLADNOSTI	Continental Automotive GmbH ovime izjavljuje da je radijska oprema tipa S180052094/TIS-03 u skladu s Direktivom 2014/53/EU. Cjeloviti tekst EU izjave o sukladnosti dostupan je na sljedećoj internetskoj adresi: http://www.mitsubishi-motors.com/en/red-doc/ Frekvencijski pojas (frekvencijski pojas) u kojem (kojima) radijska oprema radi: 433.92MHz Najveća radiofrekvencijska snaga koja se prenosi u frekvencijskom pojasu (frekvencijskim pojasima) u kojem (kojima) radijska oprema radi: -17 dBm
12_RED_IT_Italian	
DICHIARAZIONE DI CONFORMITÀ UE SEMPLIFICATA	Il fabbricante, Continental Automotive GmbH, dichiara che il tipo di apparecchiatura radio S180052094/TIS-03 è conforme alla direttiva 2014/53/UE. Il testo completo della dichiarazione di conformità UE è disponibile al seguente indirizzo Internet: http://www.mitsubishi-motors.com/en/red-doc/ Bande di frequenza di funzionamento dell'apparecchiatura radio:

	433.92MHz
	Massima potenza a radiofrequenza trasmessa nelle bande di frequenza in cui opera l'apparecchiatura radio: 10mW
13_RED_LV_Latvian	
VIENKĀRŠOTA ES ATBILSTĪBAS DEKLARĀCIJA	Ar šo Continental Automotive GmbH deklarē, ka radioiekārta S180052094/TIS-03 atbilst Direktīvai 2014/53/ES. Pilns FS atbilstības deklarācijas teksts ir pieejams šādā interneta vietnē: http://www.mitsubishi-motors.com/en/red-doc/
	Frekvenču joslā(-ās), kurā(-ās) radioiekārta darbojas: 433.92MHz
	Frekvenču joslā(-ās), kurā(-ās) darbojas radioiekārta, maksimālo pārraidītā signāle jaudu.: -17 dBm
14_RED_LT_Lithunian	
SUPAPRASTINTA ES ATITIKTIES DEKLARACIJA	As. Continental Automotive GmbH, patvirtinu, kad radijo įrenginių tipas S180052094/TIS-03 atitinka Direktivą 2014/53/ES. Visas ES atitikties deklaracijos tekstas prieinamas šiuo interneto adresu: http://www.mitsubishi-motors.com/en/red-doc/
	Dažnių juosta (-os), kurioje (-iose) veikia radijo įrenginiai: 433.92MHz
	Didžiausia radijo dažnių galia, perduodama toje (tose) dažnių juostoje (-ose), kurioje (-iose) veikia radijo įrenginiai: -17 dBm
15_RED_HU_Hungarian	
EGYSZERŰSÍTETT EUMEGFELELŐSÉGI NYILATKOZAT	Continental Automotive GmbH igazolja, hogy a S180052094/TIS-03 típusú rádióberendezés megfelel a 2014/53/EU irányelvnek. Az EU-megfelelőségi nyilatkozat teljes szövege elérhető a következő internetes címen:. http://www.mitsubishi-motors.com/en/red-doc/
	Az(ök) a frekvenciasáv(ok), amely(ek)en a rádióberendezés működik: 433.92MHz
	Az abban a frekvenciasávban vagy azokban a

	<p>frekvenciasávkobban továbbiolt maximális jelerősség, amely(ek)ben a rádióberendezés üzemei: -17 dBm</p>
16_RED_MT_Maltese	
DIKJARAZZJONI SSIMPLIFIKATA TA' KONFORMITÀ TAL-UE	<p>B'dan, Continental Automotive GmbH, niddkijara li dan it-tip ta' tagħmir tar-radju S180052094/TIS-03 huwa konformi mad-Direttiva 2014/53/UE. It-test kollu tad-dikjarazzjoni ta' konformità tal-UE huwa disponibbli f'dan l-indirizz tal-Internet li ġej: http://www.mitsubishi-motors.com/en/red-doc/</p> <p>Il-medda/meded tal-frekwenza li jahdem fihom it-tagħmir tar-radju: 433.92MHz</p> <p>Il-potenza massima tal-frekwenza tar-radju trazzmessa fil-medda/meded tal-frekwenza li jahdem fihom it-tagħmir tar-radju: -17 dBm</p>
17_RED_NL_Dutch	
VEREENVOUDIGDE EUCONFORMITEITSVERKLARING	<p>Hierbij verklaar ik, Continental Automotive GmbH, dat het type radioapparaat S180052094/TIS-03 conform is met Richtlijn 2014/53/EU. De volledige tekst van de EU-conformiteitsverklaring kan worden geraadpleegd op het volgende internetadres: http://www.mitsubishi-motors.com/en/red-doc/</p> <p>Frequentieband(en) waarin de radioapparatuur functioneert: 433.92MHz</p> <p>Maximaal radiofrequent vermogen uitgezonden in de frequentieband(en) waarin de radioapparatuur functioneert: -17 dBm</p>
18_RED_PL_Polish	
UPROSZCZONA DEKLARACJA ZGODNOŚCI UE	<p>Continental Automotive GmbH niniejszym oświadcza, że typ urządzenia radiowego S180052094/TIS-03 jest zgodny z dyrektywą 2014/53/UE. Pełny tekst deklaracji zgodności UE jest dostępny pod następującym adresem internetowym: http://www.mitsubishi-motors.com/en/red-doc/</p> <p>Zakresu(-ów) częstotliwości, w którym (których) pracuje</p>

	urządzenie radiowe: 433.92MHz
	Maksymalnej mocy częstotliwości radiowej emitowanej w zakresie(-ach) częstotliwości, w którym (których) pracuje urządzenie radiowe: -17 dBm
19_RED_PT_Portuguese	
DECLARAÇÃO UE DE CONFORMIDADE SIMPLIFICADA	O(a) abaixo assinado(a) Continental Automotive GmbH declara que o presente tipo de equipamento de rádio S180052094/TIS-03 está em conformidade com a Diretiva 2014/53/UE. O texto integral da declaração de conformidade está disponível no seguinte endereço de Internet: http://www.mitsubishi-motors.com/en/red-doc/
	A(s) banda(s) de frequências em que o equipamento de rádio funciona: 433.92MHz
	A potência máxima de radiofrequências transmitida na(s) banda(s) de frequências em que o equipamento de rádio funciona: -17 dBm
20_RED_RO_Romanian	
DECLARAȚIA UE DE CONFORMITATE SIMPLIFICATĂ	Prin prezenta, Continental Automotive GmbH declară că tipul de echipamente radio S180052094/TIS-03 este în conformitate cu Directiva 2014/53/UE. Textul integral al declarației UE de conformitate este disponibil la următoarea adresă internet: http://www.mitsubishi-motors.com/en/red-doc/
	Banda (benzile) de frecvențe în care funcționează echipamentul radio: 433.92MHz
	Puterea maximă de radiofrecvență transmisă în banda (benzile) de frecvențe în care funcționează echipamentul radio: -17 dBm
21_RED_SK_Slovak	
ZJEDNODUŠENÉ EÚ VYHLÁSENIE O ZHODE	Continental Automotive GmbH týmto vyhlasuje, že rádiové zariadenie typu S180052094/TIS-03 je v súlade so smernicou 2014/53/EÚ. Úplné EÚ vyhlásenie o zhode je k dispozícii na

	tejo internetovej adrese: http://www.mitsubishi-motors.com/en/red-doc/
	Frekvenčné pásmo resp. pásma, v ktorých rádiové zariadenie pracuje: 433.92MHz Maximálny vysokofrekvenčný výkon prenášaný vo frekvenčnom pásme, resp. pásmach, v ktorých rádiové zariadenie pracuje: -17 dBm
22_RED_SL_Slovenian	
POENOSTAVLJENA IZJAVA EU O SKLADNOSTI	Continental Automotive GmbH potrjuje, da je tip radijske opreme S180052094/TIS-03 skladen z Direktivo 2014/53/EU. Celotno besedilo izjave EU o skladnosti je na voljo na naslednjem spletnem naslovu: http://www.mitsubishi-motors.com/en/red-doc/ Frekvenčni pas ali pasovi, na katerih deluje radijska oprema: 433.92MHz Največja energija za radijsko frekvenco, preneseno po frekvenčnem pasu ali pasovih, na katerih radijska oprema deluje: -17 dBm
23_RED_FL_Finnish	
YKSINKERTAISTETTU EUVAATIMUSTENMUKAISUUSVAKUUTUS	Continental Automotive GmbH vakuuttaa, että radiolaitetyypin S180052094/TIS-03 on direktiivin 2014/53/EU mukainen. EUvaatimustenmukaisuusvakuutuksen täysimittainen teksti on saatavilla seuraavassa internetosoitteessa: http://www.mitsubishi-motors.com/en/red-doc/ Radiolaajuudet, joilla radiolaitte toimii: 433.92MHz Suurin mahdollinen lähetysteho radiolaajuuksilla, joilla radiolaitte toimii: -17 dBm
24_RED_SV_Swedish	
FÖRENKLAD EUFÖRSÄKRAN OM ÖVERENSSTÄMMELSE	Härmed försäkrar Continental Automotive GmbH att denna typ av radioutrustning S180052094/TIS-03 överensstämmer med direktiv 2014/53/EU. Den fullständiga texten till EU-försäkran om överensstämmelse finns på följande webbadress:

	http://www.mitsubishi-motors.com/en/red-doc/
	Det eller de frekvensband där radioutrustningen arbetar: 433.92MHz
	Den maximala radiofrekvensseffekt som överförs inom det eller de frekvensband där radioutrustningen arbetar: -17 dBm

OGGE19E1

Declaration of Conformity 14- 69

Manufacturer Postal Address

MITSUBISHI ELECTRIC CORPORATION
2-3-33, MIWA, SANDA-CITY, HYOGO, 669-1513, JAPAN

A) Generic information:**B) Language Text:**

Cesk [Czech]	Tímto [Mitsubishi Electric Corporation], prohlašuje, že [DY-1/CQ-0ME] jsou v souladu se směrnicí 2014/53/EU. Podrobnosti naleznete na následující internetové adrese: http://www.mitsubishi-motors.com/en/red-doc/
Dansk [Danish]	Hermed, [Mitsubishi Electric Corporation], erklærer, at [DY-1/CQ-0ME] er i overensstemmelse med direktiv 2014/53/EU. For yderligere information gå ind på følgende webadresse: http://www.mitsubishi-motors.com/en/red-doc/
Deutsch [German]	Hiermit erkläre [Mitsubishi Electric Corporation], dass [DY-1/CQ-0ME] in Übereinstimmung mit der Richtlinie 2014/53/EU stehen. Weitere Informationen erhalten Sie über folgende URL: http://www.mitsubishi-motors.com/en/red-doc/
Eesti [Estonian]	Käesolevaga [Mitsubishi Electric Corporation], teatab, et [DY-1/CQ-0ME] on kooskõlas direktiivi 2014/53/EL. Üksikasjalikuma teabe saamiseks tutvuda järgmiste URL: http://www.mitsubishi-motors.com/en/red-doc/
English [English]	Hereby, [Mitsubishi Electric Corporation], declares that [DY-1/CQ-0ME] are in compliance with Directive 2014/53/EU. For details, please access the following URL: http://www.mitsubishi-motors.com/en/red-doc/
Español [Spanish]	Por este medio, [Mitsubishi Electric Corporation], declara que [DY-1/CQ-0ME] están en conformidad con la Directiva 2014/53/UE. Para obtener más detalles, acceda a la siguiente URL: http://www.mitsubishi-motors.com/en/red-doc/
Ελληνικά [Greek]	Δια του παρόντος, [Mitsubishi Electric Corporation], δηλώνει ότι [DY-1/CQ-0ME] είναι σε συμμόρφωση με την οδηγία 2014/53/ΕΕ. Για λεπτομέρειες, επισκεφθείτε την παρακάτω διεύθυνση URL: http://www.mitsubishi-motors.com/en/red-doc/
Français [French]	Par la présente, [Mitsubishi Electric Corporation], déclare que [DY-1/CQ-0ME] sont conformes à la directive 2014/53/UE. Pour plus de détails, veuillez accéder à l'URL suivante: http://www.mitsubishi-motors.com/en/red-doc/
Italiano [Italian]	Con la presente, [Mitsubishi Electric Corporation], dichiara che [DY-1/CQ-0ME] sono in conformità con la direttiva 2014/53/UE. Per ulteriori informazioni, si prega di consultare il seguente URL: http://www.mitsubishi-motors.com/en/red-doc/
Latviski [Latvian]	Ar šo, [Mitsubishi Electric Corporation], paziņo, ka [DY-1/CQ-0ME] ir saskaņā ar Direktīvu 2014/53/ES. Lai iegūtu plašāku informāciju, lūdzu, apmeklejat šādu URL: http://www.mitsubishi-motors.com/en/red-doc/
Lietuvių [Lithuanian]	Šiuo [Mitsubishi Electric Corporation], pareiškiu, kad [DY-1/CQ-0ME] yra laikomasi Direktyvos 2014/53/ES. Dėl išsamesnės informacijos, prašome prisijungti prie šių URL: http://www.mitsubishi-motors.com/en/red-doc/
Nederlands [Dutch]	Hierbij [Mitsubishi Electric Corporation], verklaart dat [DY-1/CQ-0ME] zijn in overeenstemming met Richtlijn 2014/53/EU. Voor meer informatie, neem dan de volgende URL: http://www.mitsubishi-motors.com/en/red-doc/
Malti [Maltese]	Hawnhekk, [Mitsubishi Electric Corporation], jirdikja li [DY-1/CQ-0ME] huma konformi mad-Direttiva 2014/53/UE. Għad-dettalji, jekk jogħġbok aċċess għall-URL li ġej: http://www.mitsubishi-motors.com/en/red-doc/
Magyar [Hungarian]	Ezáltal [Mitsubishi Electric Corporation], kijelenti, hogy [DY-1/CQ-0ME] iránylevnek megfelelő 2014/53/EU. A részleteket lásd az alábbi URL: http://www.mitsubishi-motors.com/en/red-doc/
Polski [Polish]	Niniejszym [Mitsubishi Electric Corporation], deklaruje, że [DY-1/CQ-0ME] są zgodne z dyrektywą 2014/53/UE. Szczegółowe informacje można znaleźć pod następującym adresem URL: http://www.mitsubishi-motors.com/en/red-doc/

14- 70 Declaration of Conformity





OGGE19E1

Portugués [Portuguese]	Por este meio, a [Mitsubishi Electric Corporation], declara que [DY-1/CQ-0ME] estão em conformidade com a Directiva 2014/53/UE. Para obter detalhes, acesse o seguinte URL: http://www.mitsubishi-motors.com/en/red-doc/
Slovenski [Slovenian]	S tem, [Mitsubishi Electric Corporation], izjavlja, da so [DY-1/CQ-0ME] v skladu s Direktivo 2014/53/EU. Za več informacij, prosimo, pojdite na naslednji naslov: http://www.mitsubishi-motors.com/en/red-doc/
Slovenské [Slovak]	Týmto [Mitsubishi Electric Corporation], vyhlasuje, že [DY-1/CQ-0ME] sú v súlade so smernicou 2014/53/EÚ. Podrobnosti nájdete na nasledujúcej internetovej adrese: http://www.mitsubishi-motors.com/en/red-doc/
Suomi [Finnish]	Täten [Mitsubishi Electric Corporation], ilmoittaa, että [DY-1/CQ-0ME] noudattavat direktiivin 2014/53/EU. Lisätietoja, seuraavassa URL-osoitteessa: http://www.mitsubishi-motors.com/en/red-doc/
Svenska [Swedish]	Härmed [Mitsubishi Electric Corporation], förklarar att [DY-1/CQ-0ME] överensstämmer med direktiv 2014/53/EU. För mer information, gå in på följande webbadress: http://www.mitsubishi-motors.com/en/red-doc/
Íslenska [Icelandic]	Hér, [Mitsubishi Electric Corporation], segir að [DY-1/CQ-0ME] eru í samræmi við tilskipun 2014/53/ESB. Fyrir upplýsingar, vinsamlegast aðgang eftirfarandi vefsíðu: http://www.mitsubishi-motors.com/en/red-doc/
Norsk [Norwegian]	Herved [Mitsubishi Electric Corporation], erklærer at [DY-1/CQ-0ME] er i samsvar med direktiv 2014/53/EU. For flere detaljer, vennligst følgende URL: http://www.mitsubishi-motors.com/en/red-doc/
Türk [Turkish]	Burada, [Mitsubishi Electric Corporation], [DY-1/CQ-0ME] 'in 2014/53/AB sayılı Direktife uygun olduğunu beyan eder. Ayrıntılar için lütfen aşağıdaki URL'ye erişin: http://www.mitsubishi-motors.com/en/red-doc/
Româna [Romania]	Prin prezenta, [Mitsubishi Electric Corporation], declară că [DY-1/CQ-0ME] sunt conforme cu Directiva 2014/53/UE. Pentru mai multe detalii, vă rugăm să accesați următoarea adresă URL: http://www.mitsubishi-motors.com/en/red-doc/
Български [Bulgarian]	С настоящото [Mitsubishi Electric Corporation], декларира, че [DY-1/CQ-0ME] са в съответствие с Директива 2014/53/ЕС. За повече информация, моля, посетете следния URL адрес: http://www.mitsubishi-motors.com/en/red-doc/
Hrvatski [Croatian]	Ovime [Mitsubishi Electric Corporation], izjavljuje da je [DY-1/CQ-0ME] su u skladu s Direktivom 2014/53/EU. Za detalje, molimo pogledajte sljedeći URL: http://www.mitsubishi-motors.com/en/red-doc/
Македонски [Macedonian]	Со ова, [Mitsubishi Electric Corporation], изјавува дека [DY-1/CQ-0ME] се во согласност со Директивата 2014/53/EU. За повеќе детали, посетете ја следната веб-адреса: http://www.mitsubishi-motors.com/en/red-doc/
Shqiptar [Albanian]	Me anë të kësaj, [Mitsubishi Electric Corporation], deklarom se [DY-1/CQ-0ME] janë në përputhje me Direktivën 2014/53/BE. Për detaje, vizitoni URL e mëposhtme: http://www.mitsubishi-motors.com/en/red-doc/
Црногорски / Српозорски [Montenegrin]	Ovim putem, [Mitsubishi Electric Corporation], izjavljuje da je [DY-1/CQ-0ME] su u skladu sa Direktivi 2014/53/EU. Za detalje, molimo vas da pristupite sljedeći URL: http://www.mitsubishi-motors.com/en/red-doc/
ქართული [Georgian]	ამასთან, [Mitsubishi Electric Corporation], აცხადებს, რომ [DY-1/CQ-0ME] შეესაბამისობაშია დირექტივა 2014/53/EU. დამატებითი ინფორმაციისათვის, გთხოვთ, ახილოთ შემდეგი URL: http://www.mitsubishi-motors.com/en/red-doc/

COUNTRY	IMPORTER NAME	REGISTERED TRADE NAME OR REGISTERED TRADE MARK	POSTAL ADDRESS
ALBANIA	MMAI	M.M. Automobili Italia SpA	Via Giovanni da Udine 45, 20156 Milano, Italy
AUSTRIA	DENZEL Autoimport GmbH	DENZEL Autoimport GmbH	A-1230 Wien, Richard Strauss-Straße 14
BELGIUM	Beherman	Beherman Motors NV/SA	Industrieweg 3, Bornem Belgium
BULGARIA	Balkan Star Motors EOOD	Balkan Star Motors EOOD	Bulgaria, 1510 Sofia, Rezbarska str. 5
CROATIA	LMG Autokuća d.o.o.	LMG Autokuća d.o.o.	Velikogorička 18a,10419 Staro Čiče, CROATIA
CYPRUS	FAIRWAYS	Fairways Ltd	100 Arch. Makarios Avenue, P.O. BOX 51023,3021 Limmasol, Cyprus
CZECH	M Motors CZ s.r.o.	M Motors CZ s.r.o.	Na Chodovci 2457/1, Praha 4 Sporilov, ZIP 141 00, Czech Rep.
DENMARK	MMDk	MMC Danmark A/S	Hovedvejen 3 2600 Glostrup, Denmark
ESTONIA	AS SILBERAUTO	Silberauto	Järvevana tee 11, Tallinn 11314, Estonia
FINLAND	Delta Motor	Delta Motor Group Oy	Vaisalantie 6, 02130 Espoo, Finland
FRANCE	MMAF	M Motors Automobiles France SAS	1, avenue du Fief PA les Béthunes 95310 Saint Ouen L'Aumône FRANCE
GERMANY	MMD Automobile GmbH	MMD Automobile GmbH	Stahlstr. 42-44, 65428 Rüsselsheim Deutschland
GREECE	Saracakis Brothers	SARACAKIS BROTHERS S.A.	71, Athinon Ave., GR-101 73 Athens, Greece
HUNGARY	MM INPORT KFT	MM Import kft	Mogyoródi út24-40, H-1149 Budapest,Hungary
ICELAND	HEKLA	Hekla Hf.	Laugavegur 172-174, P.O.Box 5310, 125 Reykjavik, Iceland
IRELAND	MMC Commercials	MMC Commercials Unlimited	John F. Kennedy Drive, Naas Road, Dublin 12, Ireland
ITALY	MMAI	M.M. Automobili Italia SpA	Via Giovanni da Udine 45, 20156 Milano, Italy
LATVIA	MML Imports SIA	MML Imports SIA	ir 32 Lielirbes Street, Riga, LV1046, Latvia.
LITHUANIA	JSC Autovytaras	JSC Autovytaras, company code:126413861	P.Žadeikos str. 1B, Vilnius LT-06319, Lithuania
LUXEMBOURG	Beherman	Beherman Motors NV/SA	Industrieweg 3, Bornem Belgium
MALTA	INDUSTRIAL Motors Ltd	Industrial Motors Limited	Mizzi House, National Road,Blata I-Bajda HMR 9010,Malta
MOLDOVA	Auto Space S.R.L.	AUTO SPACE	str. Bucuriei 18a, Chisinau, Republica Moldova, MD-2064
NETHERLANDS	MMSN	Mitsubishi Motor Sales Nederland B.V.	Postbus 9090 1180 MB Amstelveen Bovenkerkerweg 6-8, 1185 XE Amstelveen, The Netherlands
NORWAY	MMCN	MMC Norge AS	Ostre Aker vei 62, 0581 Oslo P.O. Box 6843 Rodelokka, 0504 Oslo, Norway
POLAND	MMCP	MMC Car Poland Sp.z o.o.	ul.,17 Stycznia 45A,02-146,Warsaw,Poland
PORTUGAL	MBP Automoveis Portugal,S.A.	MBP Automoveis Portugal,S.A.	Rua Dr. José Espírito Santo, 38, 1950-097 LISBOA, Portugal
ROMANIA	M CAR TRADING	M CAR TRADING	2nd,Expozitiei Blv,district 1,012103 BUCHAREST,BULGARIA
SLOVAKIA	M Motors SK s.r.o.	M Motors SK s.r.o.	Panonska cesta 33, Bratislava, Slovakia, ZIP 851 04
SLOVENIA	AC-Mobil d.o.o.	AC-Mobil, d.o.o. Ljubljana	Baragova 9, 1113 Ljubljana
SPAIN	B&M Automóviles España, S.A.	B&M Automóviles España, S.A.	calle Alcalá, 65, 28014 Madrid, Spain
SWEDEN	MMCS	MMC Bilar Sverige AB	Bergkallavagen 32, SE-192 07 Sollentuna, Sweden
SWITZERLAND	MM Automobile Schweiz AG	MM Automobile Schweiz AG	Lischmatt 17, 4624 Harkingen, Switzerland
U.K.	CCC	The Colt Car Company Limited	Watermoor, Cirencester Gloucestershire GL7 1LF, The United Kingdom
GEORGIA	Caucasus Motors Ltd.	Caucasus Motors Ltd.	12th km David Agmashenebeli Alley Digomi, 0131 Tbilisi, Georgia
TAHITI	SOPADEF S.A.	SOPADEF S.A.	Route de ceinture de Tapaerui, BP 1617, 98713 Papeete, Tahiti French Polynesia

14- 72 Declaration of Conformity

OGGE19E1

MANUFACTURERS DECLARATION OF CONFORMITY	
	For 
Pantagraph Car Jack Models PJM700, PJM800, PJM1000 & PJM1200	
Manufactured by Taihei Industrial Co., Ltd. No. 45-1, Kagekatsu-Cho, Fushimi-Ku, Kyoto 612-8307 Japan	Technical File compiled and held in the EU, on behalf of the manufacturer by TRac Global Ltd 100 Froblsher Business Park, Leigh Sinton Road, Malvern, Worcestershire, WR14 1DX United Kingdom
Standards used as guidance Machinery Directive Annex I of 2009/42/EC with reference to : EN 1494:2000/A1:2008	
Means of Conformity The Product is in conformity with EC law as approximated by the Machinery Directive 2006/42/EC, As detailed in Technical Documentation File No 2136 Revision 2, March 2012	
Signature of Responsible Person: 	Mr. Masato Nasu President Taihei Industrial Co., Ltd.
Signature of the person in the EU holding the Technical File: 	Mr. Neil Roche EVC Product Manager TRac Global Ltd.
MACHINE SERIAL No.	Date: 13 th March 2012
	Certificate No. 17-0074-1 DoFC Issue 3

Deutsch (German)	Français (French)	Italiano (Italian)
<p>KONFORMITÄTSERKLÄRUNG DES HERSTELLERS Für Pantagraph Wagenheber, Modelle PJM700, PJM800, PJM1000 & PJM1200</p> <p>Hergestellt von Taihei Industrial Co., Ltd. No.49-1, Kagekatsu-cho, Fushimi-ku, Kyoto 612-8307 Japan</p> <p>Technische Dokumentation zusammengestellt und bereitgehalten in der EU, im Namen des Herstellers durch TRaC Global Ltd 100 Frobisher Business Park, Leigh Sinton Road, Malvern, Worcestershire, WR14 1BX Vereinigtes Königreich</p> <p>Als Leitlinie der Maschinenrichtlinie verwendete Normen Anhang I der 2006/42/EG mit Bezug auf: EN 1494:2000/A1:2008</p> <p>Konformität Das Produkt steht in Übereinstimmung mit den der Maschinenrichtlinie 2006/42/EG angeglichenen EG-Gesetzen,</p> <p>Entsprechend der Technischen Dokumentation Akte Nr. 2136 2. Revision, März 2012</p> <p>Unterschrift der verantwortlichen Person: Herr Masato Nasu Präsident Taihei Industrial Co., Ltd.</p> <p>Unterschrift der Person, die die technische Dokumentation in der EU bereithält: Herr Neil Roche EMV-Produktmanager TRaC Global Ltd.</p> <p>MASCHINENSERIENN.R. Datum: 13. März 2012 Zertifikatsnr. 17-0074-1 DofC 3. Ausgabe</p>	<p>DECLARATION DE CONFORMITE DU FABRICANT Pour Pantagraph Car Jack, modèles PJM700, PJM800, PJM1000 & PJM1200</p> <p>Fabriqué par Taihei Industrial Co., Ltd. No.49-1, Kagekatsu-cho, Fushimi-ku, Kyoto 612-8307 Japon</p> <p>Fichier technique compilé et maintenu dans l'UE, au nom du fabricant en TRaC Global Ltd 100 Frobisher Business Park, Leigh Sinton Road, Malvern, Worcestershire, WR14 1BX Royaume-Uni</p> <p>Normes utilisées pour le guide de l'appareil Annexe I de 2006/42/EC en se reportant à la section : EN 1494:2000/A1:2008</p> <p>Moyens de conformité Le produit est en conformité avec la loi CE comme approximativement par la directive sur la machinerie 2006/42/CE,</p> <p>Comme décrit dans le fichier de la documentation technique n°2136 révision 2, mars 2012</p> <p>Signature de la personne responsable : M. Masato Nasu Président Taihei Industrial Co., Ltd.</p> <p>Signature de la personne dans l'UE gardant le fichier technique : M. Neil Roche Chef de produit EMC TRaC Global Ltd.</p> <p>N° DE SERIE DE LA MACHINE Date : 13 mars 2012 N° de certificat 17-0074-1 DofC Edition 3</p>	<p>DICHIARAZIONE DI CONFORMITÀ DEL PRODUTTORE Per Cric a pantografo, modelli PJM700, PJM800, PJM1000 & PJM1200</p> <p>Prodotto da Taihei Industrial Co., Ltd. No.49-1, Kagekatsu-cho, Fushimi-ku, Kyoto 612-8307 Giappone</p> <p>File tecnico compilato e detenuto nell'UE per conto del produttore da TRaC Global Ltd 100 Frobisher Business Park, Leigh Sinton Road, Malvern, Worcestershire, WR14 1BX Regno Unito</p> <p>Standard utilizzati come guida della direttiva macchine Appendice I di 2006/42/CE con riferimento a: EN 1494:2000/A1:2008</p> <p>Certificato di conformità Il prodotto è conforme alle leggi della CE poiché rispetta la direttiva macchine 2006/42/CE,</p> <p>Come dettagliato nel file della documentazione tecnica N. 2136, revisione 2 marzo 2012</p> <p>Firma del responsabile: Masato Nasu Presidente Taihei Industrial Co., Ltd.</p> <p>Firma della persona che detiene il file tecnico nell'UE: Neil Roche EMC Product Manager TRaC Global Ltd.</p> <p>N. SERIALE DELLA MACCHINA Data: 13 marzo 2012 Certificato N. 17-0074-1 DofC Issue 3</p>

Nederland (Dutch)	Dansk (Danish)	Ελληνικά (Greek)
<p>FABRIKANTENVERKLARING VAN CONFORMITEIT Voor Pantagraph Autoknik, Modellen PJM700, PJM800, PJM1000 & PJM1200</p> <p>Geproduceerd door Taihei Industrial Co., Ltd. No.49-1, Kagekatsu-cho, Fushimi-ku, Kyoto 612-8307 Japan</p> <p>Technisch Dossier samengesteld en gehouden in de EU, namens de fabrikant door TRaC Global Ltd 100 Frobisher Business Park, Leigh Sinton Road, Malvern, Worcestershire, WR14 1BX United Kingdom</p> <p>Normen als leidraad Machinerichtlijn</p> <p>Bijlage I van 2006/42/EG met betrekking tot: EN 1494:2000 / A1: 2008</p> <p>Middel van conformiteit Het product is in overeenstemming met het EG-recht zoals benaderd door de Machinerichtlijn 2006/42/EG, Zoals beschreven in Technische Documentatie Dossier nr. 2136 Revisie 2, maart 2012</p> <p>Handtekening van de bevoegde persoon: De heer Masato Nasu President Taihei Industrial Co., Ltd.</p> <p>Handtekening van de persoon in de EU die het Technisch Dossier: De heer Neil Roche EMC Product Manager TRaC Global Ltd.</p> <p>MACHINE Serienummer Datum: 13 maart 2012 Certificaat nr. 17-0074-1 DofC Uitgave 3</p>	<p>PRODUCENTENS OVERENSSTEMMELSESERKLÆRING for Pantografisk donkraft i modelleme PJM700, PJM800, PJM1000 & PJM1200</p> <p>Fremstillet af Taihei Industrial Co., Ltd. No.49-1, Kagekatsu-cho, Fushimi-ku, Kyoto 612-8307 Japan</p> <p>Teknisk fil kompileret og holdt inden for EU på vegne af producenten TRaC Global Ltd 100 Frobisher Business Park, Leigh Sinton Road, Malvern, Worcestershire, WR14 1BX England</p> <p>Standarder anvendt som vejledende maskindirektiv</p> <p>Bilag I i 2006/42/EU med reference til: EN 1494:2000/A1:2008</p> <p>Overensstemmelseserklæringens betydning Produktet er i overensstemmelse med EU-lovgivningen defineret af Maskindirektivet 2006/42/EF, Som beskrevet i fil med teknisk dokumentation nr. 2136 Revidering 2, marts 2012</p> <p>Signatur for ansvarlig: Hr. Masato Nasu Formand Taihei Industrial Co., Ltd.</p> <p>Signatur fra personen i EU, der besidder den tekniske fil: Hr. Neil Roche EMC-produktchef TRaC Global Ltd.</p> <p>MASKINENS SERIENR. Dato: 13. marts 2012 Certifikatnr. 17-0074-1 DofC Problemstilling 3</p>	<p>ΔΗΛΩΣΗ ΣΥΜΜΟΡΦΩΣΗΣ ΤΩΝ ΚΑΤΑΣΚΕΥΑΣΤΩΝ Για Γρύλος Αυτοκινήτου Pantagraph, Μοντέλα PJM700, PJM800, PJM1000 και PJM1200</p> <p>Κατασκευάστηκε από την Taihei Industrial Co., Ltd. No.49-1, Kagekatsu-cho, Fushimi-ku, Kyoto 612-8307 Ιαπωνία</p> <p>Τεχνικό Αρχείο συντασσόμενο και διατηρούμενο στην ΕΕ, εξ ονόματος του κατασκευαστή από την TRaC Global Ltd 100 Frobisher Business Park, Leigh Sinton Road, Malvern, Worcestershire, WR14 1BX Ηνωμένο Βασίλειο</p> <p>Πρότυπα που χρησιμοποιούνται ως κατευθυντήρια Οδηγία περί Μηχανημάτων Παράρτημα I της 2006/42/EK με αναφορά στη: EN 1494:2000/A1:2008</p> <p>Μέσα Συμμόρφωσης Το Προϊόν είναι σύμφωνο με την κοινοτική νομοθεσία, όπως προσεγγίζεται από την Οδηγία για τα Μηχανήματα 2006/42/EK, όπως αναφέρεται λεπτομερώς στην Τεχνική Τεκμηρίωση με Αρ. Αρχείου 2136 Αναθεώρηση 2, Μαρτίου 2012</p> <p>Υπογραφή του Υπεύθυνου Ατόμου: κ. Masato Nasu Πρόεδρος Taihei Industrial Co., Ltd.</p> <p>Υπογραφή του ατόμου στην ΕΕ που διατηρεί το Τεχνικό Αρχείο: κ. Neil Roche Διευθυντής Προϊόντων Ηλεκτρομαγνητικής Συμβατότητας TRaC Global Ltd.</p> <p>ΣΕΙΡΙΑΚΟΣ ΑΡ. ΣΥΣΚΕΥΗΣ Ημερομηνία: 13 Μαρτίου 2012 Αρ. Πιστοποιητικού 17-0074-1 DofC Έκδοση 3</p>

Español (Spanish)	Português (Portuguese)	Svenska (Swedish)
<p>DECLARACIÓN DE CONFORMIDAD DEL FABRICANTE Para Gato pantógrafo para coche, modelos PJM700, PJM800, PJM1000 & PJM1200</p> <p>Fabricado por Taihei Industrial Co., Ltd. Núm. 49-1, Kagekatsu-cho, Fushimi-ku, Kioto 612-8307 Japón</p> <p>Archivo técnico compilado y mantenido en la UE, en nombre del fabricante por TRaC Global Ltd 100 Frobisher Business Park, Leigh Sinton Road, Malvern, Worcestershire, WR14 1BX Reino Unido</p> <p>Estándares usados como guía Directiva sobre maquinaria Anexo I de 2006/42/CE con referencia a: EN 1494:2000/A1:2008</p> <p>Medidas de conformidad El producto se encuentra en conformidad con la ley de la CE según se aproxima por la Directiva de máquinas 2006/42/CE,</p> <p>Como se detalla en el Archivo de documentación técnica Núm. 2136 Revisión 2, marzo de 2012</p> <p>Firma de la persona responsable: Sr. Masato Nasu Presidente Taihei Industrial Co., Ltd.</p> <p>Firma de la persona en la UE que sostiene el Archivo técnico: Sr. Neil Roche Gestor de producto EMC TRaC Global Ltd.</p> <p>NÚM. DE SERIE DE LA MÁQUINA Fecha: 13 de marzo de 2012 Núm. de certificado 17-0074-1 DofC Edición 3</p>	<p>DECLARAÇÃO DE CONFORMIDADE DOS FABRICANTES Para Macaco para Carro Pantagraph, Modelos PJM700, PJM800, PJM1000 e PJM1200</p> <p>Fabricado por Taihei Industrial Co., Ltd. N.º 49-1, Kagekatsu-cho, Fushimi-ku, Quioto 612-8307 Japão</p> <p>Ficha Técnica compilada e mantida na UE, em nome do fabricante por TRaC Global Ltd 100 Frobisher Business Park, Leigh Sinton Road, Malvern, Worcestershire, WR14 1BX Reino Unido</p> <p>Normas usadas como orientação da Diretiva de Maquinaria Anexo I da 2006/42/EC com referência a: EN 1494:2000/A1:2008</p> <p>Meios de Conformidade O Produto está em conformidade com a lei CE como aproximado através da Diretiva Relativa a Máquinas 2006/42/CE,</p> <p>Como detalhado na Ficha de Documentação Técnica N.º 2136 Revisão 2, de Março de 2012</p> <p>Assinatura da Pessoa Responsável: Sr. Masato Nasu Presidente Taihei Industrial Co., Ltd.</p> <p>Assinatura da pessoa que detêm a Ficha Técnica na UE: Sr. Neil Roche Gestor de Produto EMC TRaC Global Ltd.</p> <p>N.º DE SÉRIE DA MÁQUINA Data: 13 de Março de 2012 Certificado N.º 17-0074-1 DofC Edição 3</p>	<p>TILLVERKARENS FÖRSÄKRAN OM ÖVERENSSTÄMMESE För Pantagraph domkraft för bil, modellerna PJM700, PJM800, PJM1000 & PJM1200</p> <p>Tillverkad av Taihei Industrial Co., Ltd. No.49-1, Kagekatsu-cho, Fushimi-ku, Kyoto 612-8307 Japan</p> <p>Teknisk fil sammanställd och förvarad i EU, å tillverkarens vägnar genom TRaC Global Ltd 100 Frobisher Business Park, Leigh Sinton Road, Malvern, Worcestershire, WR14 1BX Storbritannien</p> <p>Standarder som används som vägledning för maskindirektivet Bilaga I i 2006/42/EG med avseende på: EN 1494:2000/A1:2008</p> <p>Överensstämmelse Produkten överensstämmer med EG-lagstiftningen som approximeras av Maskindirektivet 2006/42/EG,</p> <p>I enlighet med Teknisk dokumentationsfil nr. 2136 revision 2, mars 2012</p> <p>Signatur av ansvarig person: Mr. Masato Nasu Ordförande Taihei Industrial Co., Ltd.</p> <p>Signatur av den person i EU som förvarar den tekniska filen: Mr Neil Roche EMC Produktchef TRaC Global Ltd.</p> <p>MASKINENS SERIENUMMER Datum: 13 mars 2012 Certifikat nr. 17-0074-1 DofC Utgåva 3</p>

Suomi/Suomen kieli (Finnish)	Čeština (Czech)	Magyar (Hungarian)
<p>VALMISTAJAN VAATIMUSTENMUKAISUUSVAKUUTUS Malleille Pantagraph-autonosturi, mallit PJM700, PJM800, PJM1000 & PJM1200</p> <p>Valmistaja Taihei Industrial Co., Ltd. No.49-1, Kagekatsu-cho, Fushimi-ku, Kyoto 612-8307 Japan</p> <p>Teknisen asiakirjan on laatinut ja sitä säilyttää EU:ssa valmistajan puolesta TRaC Global Ltd 100 Frobisher Business Park, Leigh Sinton Road, Malvern, Worcestershire, WR14 1BX United Kingdom</p> <p>Ohjeena käytetyt standardit Konedirektiivi 2006/42/EY:n liite I viitaten standardiin: EN 1494:2000/A1:2008</p> <p>Vaatimustenmukaisuuden sisältö Tuote on EY:n lain mukainen konedirektiivin 2006/42/EY mukaisesti, Kuten on selitetty teknisessä asiakirjassa nro 2136 versio 2, maaliskuuta 2012</p> <p>Vastuuhenkilön allekirjoitus: Mr. Masato Nasu Puheenjohtaja Taihei Industrial Co., Ltd.</p> <p>Teknisestä asiakirjasta EU:ssa vastaavan henkilön allekirjoitus: Mr Neil Roche EMC-tuotepäällikkö TRaC Global Ltd.</p> <p>KONEEN SARJANRO Päivämäärä: 13. maaliskuuta 2012 Sertifikaatin nro 17-0074-1 DoFC-numero 3</p>	<p>PROHLÁŠENÍ VÝROBCE O SHODĚ Pro Automobilový plošinový zvedák, modely PJM700, PJM800, PJM1000 & PJM1200</p> <p>Výrobno společnost Taihei Industrial Co., Ltd. Č. 49-1, Kagekatsu-cho, Fushimi-ku, Kyoto 612-8307 Japonsko</p> <p>Technický soubor sestaven a uložen v EU, jménem výrobce v TRaC Global Ltd 100 Frobisher Business Park, Leigh Sinton Road, Malvern, Worcestershire, WR14 1BX Velká Británie</p> <p>Doporučené normy k použití Směnice o strojních zařízeních Dodatek I k 2006/42/EC s odkazem na: EN 1494:2000/A1:2008</p> <p>Prostředky pro shodu Výrobek vyhovuje předpisům ES vyjádřeným ve směnici o strojních zařízeních 2006/42/ES, Jak je podrobně uvedeno ve Složce technické dokumentace č. 2136 revize 2, března 2012</p> <p>Podpis odpovědné osoby: p. Masato Nasu Předseda Taihei Industrial Co., Ltd.</p> <p>Podpis osoby v EU uchováající Technickou složku: p. Neil Roche EMC Výrobní manažer TRaC Global Ltd.</p> <p>SÉRIOVÉ Č. STROJE Datum: 13. března 2012 Certifikát č. 17-0074-1 DoFC vydání 3</p>	<p>GYÁRTÓI MEGFELELŐSÉGI NYILATKOZAT A Pantagraph Autóemelő PJM700, PJM800, PJM1000 & PJM1200 modelljeihez</p> <p>Gyártó Taihei Industrial Co., Ltd. No.49-1, Kagekatsu-cho, Fushimi-ku, Kyoto 612-8307 Japan</p> <p>Az EU-ban összeállított és megtartott Műszaki Akta, a gyártó részéről TRaC Global Ltd 100 Frobisher Business Park, Leigh Sinton Road, Malvern, Worcestershire, WR14 1BX United Kingdom</p> <p>Az irányadó Gépészeti irányelvként használt szabványok A 2006/42/EC I. melléklete, az EN 1494:2000/A1:2008-ra hivatkozva</p> <p>A megfelelőség eszközei A Termék megfelel az EK törvényeinek, a Gépi berendezésekre vonatkozó 2006/42/EK irányelvek alapján, A 2136. számú Műszaki Dokumentációs Akta 2., 2012. március javított kiadásában részletezettek szerint</p> <p>Felelős személy aláírása: Mr. Masato Nasu Elnök Taihei Industrial Co., Ltd.</p> <p>A Műszaki Aktát az EU-ban betartó személy aláírása: Mr Neil Roche EMC Termékmenedzser TRaC Global Ltd.</p> <p>GÉP SOROZATSZÁMA Datum: 2012. március 13. Tanúsítvány sz. 17-0074-1 DoFC 3. kiadás</p>

Polski (Polish)	Slovenský (Slovak)	Eesti (Estonian)
<p>DEKLARACJA ZGODNOŚCI PRODUCENTA Dotycząca Pantografowy podnośnik samochodowy, modele PJM700, PJM800, PJM1000 i PJM1200</p> <p>Wyprodukowane przez Taihei Industrial Co., Ltd. No.49-1, Kagekatsu-cho, Fushimi-ku, Kioto 612-8307 Japonia</p> <p>Dokumentacja techniczna sporządzona i przechowywana w UE w imieniu producenta przez TRaC Global Ltd 100 Frobisher Business Park, Leigh Sinton Road, Malvern, Worcestershire, WR14 1BX Wielka Brytania</p> <p>Normy stosowane zgodnie z zaleceniami dyrektywy maszynowej Załącznik I dyrektywy 2006/42/WE w odniesieniu do: EN 1494:2000/A1:2008</p> <p>Zgodność z przepisami Produkt spełnia wymogi prawa WE zgodnie z Dyrektywą Maszynową 2006/42/WE, Zgodnie ze szczegółowym opisem w dokumentacji technicznej nr 2136 rewizja 2, marca 2012 r.</p> <p>Podpis osoby odpowiedzialnej: Pan Masato Nasu Prezes Taihei Industrial Co., Ltd.</p> <p>Podpis osoby w UE pozostającej w posiadaniu dokumentacji technicznej: Pan Neil Roche Menedżer Produktów EMC TRaC Global Ltd.</p> <p>Nr SERYJNY MASZYNY Data: 13 marca 2012 r. Nr certyfikatu 17-0074-1 DofC wyd. 3</p>	<p>VYHLÁSENIE VÝROBCU O ZHODE pre Automobilový plošinový zdvihák, modely PJM700, PJM800, PJM1000 a PJM1200</p> <p>Výrobca Taihei Industrial Co., Ltd. No.49-1, Kagekatsu-cho, Fushimi-ku, Kyoto 612-8307 Japonsko</p> <p>Technický súbor zostavený a uložený v EÚ v zastúpení výrobcu TRaC Global Ltd 100 Frobisher Business Park, Leigh Sinton Road, Malvern, Worcestershire, WR14 1BX Veľká Británia</p> <p>Normy použité podľa smerníc o strojových zariadeniach Príloha I 2006/42/ES s odkazom na: EN 1494:2000/A1:2008</p> <p>Prostriedky pre zhodu Tento výrobok je v súlade so zákonmi EÚ podľa smernice o strojových zariadeniach 2006/42/ES, Ako je uvedené v technickej dokumentácii č. 2136 revízia č. 2, marec 2012</p> <p>Podpis zodpovednej osoby: Mr. Masato Nasu Riaditeľ Taihei Industrial Co., Ltd.</p> <p>Podpis osoby v EÚ držiacej technickú dokumentáciu: Mr Neil Roche Produktový manažér EMC TRaC Global Ltd.</p> <p>VÝROBNÉ ČÍSLO ZARIADENIA Dátum: 13. marec 2012 Certifikát č. 17-0074-1 Vyhl. o zhode 3.vydanie</p>	<p>TOOTJATE VASTAVUSDEKLARATSIOON toodetele Autotungraud Pantagraph, mudelid PJM700, PJM800, PJM1000 ja PJM1200</p> <p>Tootja Taihei Industrial Co., Ltd. No.49-1, Kagekatsu-cho, Fushimi-ku, Kyoto 612-8307 Japan (Jaapan)</p> <p>Tehnilise toimiku koostaja ja selle hoidja tootja nimel Elis TRaC Global Ltd 100 Frobisher Business Park, Leigh Sinton Road, Malvern, Worcestershire, WR14 1BX United Kingdom (Ühendkuningriik)</p> <p>Suunistena kasutatud standardid Masinate direktiiv 2006/42/EC lisa I viitematerjaliga standardist EN 1494:2000/A1:2008</p> <p>Vastavusnormatiivid Antud toode on vastavuses EÜ seadustega, mis on ühtlustatud masinate direktiiviga 2006/42/EÜ, Vastavalt üksikasjalisele kirjeldusele tehnilise dokumentatsiooni toimikus nr 2136, redaktsioon 2, märts 2012</p> <p>Vastutava isiku allkiri: Mr. Masato Nasu President Taihei Industrial Co., Ltd.</p> <p>Tehnilise dokumentatsiooni hoidja allkiri ELIS: Mr Neil Roche EMC tootejuht TRaC Global Ltd.</p> <p>MASINA SEERIANUMBER Kuupäev: 13. märts 2012 Sertifikaat nr 17-0074-1 DofC, väljaanne 3</p>

Lietuvių kalba (Lithuanian)	Latviešu valoda (Latvian)	Slovenščina (Slovenian)
<p>GAMINTOJO ATITIKTIES DEKLARACIJA Skirta šiems modeliams Žirklinis automobilinis domkratas, modeliai PJM700, PJM800, PJM1000 ir PJM1200</p> <p>Pagaminta Taihei Industrial Co., Ltd. No.49-1, Kagekatsu-cho, Fushimi-ku, Kiotas 612-8307 Japonija</p> <p>Techninė byla sudaryta ir laikoma ES, gamintojo vardu</p> <p>TRaC Global Ltd 100 Frobisher Business Park, Leigh Sinton Road, Malvern, Worcestershire, WR14 1BX Jungtinė Karalystė</p> <p>Naudojami Mašinų direktyvoje nurodyti standartai Direktyvos 2006/42/EB I priedas su nuoroda į: EN 1494:2000/A1:2008</p> <p>Atitikties apibūdinimas Šis gaminytis atitinka EB įstatymus, apibrėžtus Mašinų direktyvoje 2006/42/EB, Kaip nurodyta Techninės dokumentacijos byloje Nr. 2136, 2-iojoje pataisoje, 2012 m. kovo mėn.</p> <p>Atsakingo asmens parašas: P. Masato Nasu Prezidentas Taihei Industrial Co., Ltd.</p> <p>Asmens, kuriam ES priklauso Techninė dokumentacija, parašas: P. Neil Roche EMC gamybos vadovas TRaC Global Ltd.</p> <p>MAŠINOS SERIJOS Nr. Data: 2012 m. kovo 13 d. Sertifikato Nr. 17-0074-1 DofC, 3-iasis leidimas</p>	<p>RAŽOTĀJA ATBILSTĪBAS DEKLARĀCIJA Izstrādājums Pantogrāfa tipa automobiļa domkrats, modeļi PJM700, PJM800, PJM1000 un PJM1200</p> <p>Ražotājs Taihei Industrial Co., Ltd. No.49-1, Kagekatsu-cho, Fushimi-ku, Kyoto 612-8307 Japan</p> <p>Tehniskais fails ir kompilēts un to uzglabā ES ražotāja vārdā</p> <p>TRaC Global Ltd 100 Frobisher Business Park, Leigh Sinton Road, Malvern, Worcestershire, WR14 1BX United Kingdom</p> <p>Standarti, kas izmantoti kā Mehānismu direktīvas vadlīnijas direktīvas 2006/42/EK Pielikums I ar atsauci uz EN 1494:2000/A1:2008</p> <p>Atbilstības nodrošināšanas līdzekļi Izstrādājums atbilst EK likumiem, kas tuvināti ar Mašīnu direktīvu 2006/42/EK, Kā detalizēti norādīts Tehniskās dokumentācijas failā Nr. 2136, 2. pārstrādātais izdevums, 2012. g. Marts</p> <p>Atbildīgās personas paraksts: Masato Nasu k-gs Prezidents Taihei Industrial Co., Ltd.</p> <p>Personas, kas glabā tehnisko failu ES, paraksts: Neil Roche k-gs EMC produktu menedžeris TRaC Global Ltd.</p> <p>MEHĀNISMA SĒRIJAS Nr. Datums: 2012. gada 13. Marts Sertifikāta Nr. 17-0074-1 DofC, 3. izdevums</p>	<p>IZJAVA PROIZVAJALCEV O SKLADNOSTI Za Dvigalka Pantagraph, Modeli PJM700, PJM800, PJM1000 & PJM1200</p> <p>Proizvajaja Taihei Industrial Co., Ltd. No.49-1, Kagekatsu-cho, Fushimi-ku, Kjoto 612-8307, Japonska</p> <p>Tehnično dokumentacijo se, v imenu proizvajalca, za EU zbira in hrani na TRaC Global Ltd 100 Frobisher Business Park, Leigh Sinton Road, Malvern, Worcestershire, WR14 1BX Združeno kraljestvo</p> <p>Standarti se uporabljajo kot vodilo Direktive o strojih Aneks I k 2006/42/ES s sklicem na: EN 1494:2000/A1:2008</p> <p>Skladnost Proizvod je v skladu z zakonodajo ES, kot navaja Direktiva o strojih 2006/42/ES, Kot je podrobno opisano v Tehnični dokumentaciji številka dokumenta 2136 revizija 2, marec 2012</p> <p>Podpis odgovorne osebe: G. Masato Nasu Predsednik Taihei Industrial Co., Ltd.</p> <p>Podpis osebe v EU, ki hrani tehnično dokumentacijo: G. Neil Roche EMC Produktni vodja TRaC Global Ltd.</p> <p>SERIJSKA ŠT. STROJA Datum: 13. marec 2012 Št. certifikata 17-0074-1 DofC Izdaja 3</p>

Български (Bulgarian)	Român (Romanian)	Hrvatski (Croatian)
<p>ДЕКЛАРАЦИЯ ЗА СЪОТВЕТСТВИЕ НА ПРОИЗВОДИТЕЛЯ За Авто крик тип пантограф, модели PJM700, PJM800, PJM1000 и PJM1200</p> <p>Произведено от Taihei Industrial Co., Ltd. No.49-1, Kagekatsu-cho, Fushimi-ku, Kyoto 612-8307 Japan</p> <p>Техническото досие е изготвено и се съхранява в ЕС от името на производителя от TRaC Global Ltd 100 Frobisher Business Park, Leigh Sinton Road, Malvern, Worcestershire, WR14 1BX United Kingdom</p> <p>Стандартите, използвани като ръководство за директива за машините Приложение I от 2006/42/EC с позоваване на: EN 1494:2000/A1:2008 Съответствие с изискванията Продуктът отговаря на законодателството на ЕО, съгласно Директива за машините 2006/42/EC, Както е описано подробно в Папка с техническа документация No. 2136 редакция 2, март 2012</p> <p>Подпис на отговорното лице: Г-н Масато Насу Президент Taihei Industrial Co., Ltd.</p> <p>Подпис на лицето в ЕС, притежаващо техническото досие: Г-н Нийл Рош Продуктов мениджър за EMC TRaC Global Ltd.</p> <p>СЕРИЕН No. НА МАШИНАТА Дата: 13 март 2012г. Сертификат No. 17-0074-1 DofC издание 3</p>	<p>DECLARAȚIA DE CONFORMITATE A PRODUCĂTORULUI Pentru Cric pantograf pentru automobile, modelele PJM700, PJM800, PJM1000 & PJM1200</p> <p>Produs de Taihei Industrial Co., Ltd. No.49-1, Kagekatsu-cho, Fushimi-ku, Kyoto 612-8307 Japonia</p> <p>Dosarul tehnic elaborat și păstrat în UE în numele producătorului de către TRaC Global Ltd 100 Frobisher Business Park, Leigh Sinton Road, Malvern, Worcestershire, WR14 1BX Regatul Unit</p> <p>Standarde utilizate ca linii directoare în Directiva privind echipamentele tehnice Anexa I la Directiva 2006/42/CE cu trimitere la: EN 1494:2000/A1:2008 Mijloace de asigurare a conformității Produsul respectă legislația CE, astfel cum este aproximată de Directiva Mașini 2006/42/CE și cum este detaliată în Dosarul de documentație tehnică nr. 2136, revizia 2, martie 2012</p> <p>Semnătura persoanei responsabile: DI. Masato Nasu Președinte Taihei Industrial Co., Ltd.</p> <p>Semnătura persoanei din UE care păstrează Dosarul tehnic: DI. Neil Roche Manager Produs EMC TRaC Global Ltd.</p> <p>NR. DE SERIE ECHIPAMENT Data: 13 martie 2012 Certificat nr. 17-0074-1 DofC Ediția 3</p>	<p>PROIZVOĐAČEVA IZJAVA O SUKLADNOSTI Za Pantagrafska auto dizalica, Modeli PJM700, PJM800, PJM1000 & PJM1200</p> <p>Proizvodi Taihei Industrial Co., Ltd. No.49-1, Kagekatsu-cho, Fushimi-ku, Kyoto 612-8307 Japan</p> <p>Tehnički dokument sastavljen i držan u EU, u ime proizvođača</p> <p>TRaC Global Ltd 100 Frobisher Business Park, Leigh Sinton Road, Malvern, Worcestershire, WR14 1BX Ujedinjeno Kraljevstvo</p> <p>Standardi korišteni kao snjemnice Direktive o strojevima</p> <p>Dodatak I iz 2006/42/EC s povezivanjem s: EN 1494:2000/A1:2008 Značenje sukladnosti Proizvod je sukladan sa zakonima EK po Direktivi o strojevima 2006/42/EC, Kao što je navedeno u Tehničkoj dokumentaciji dokument broj 2136 revizija 2, ožujka 2012.</p> <p>Potpis ovlaštene osobe: G. Masato Nasu Predsjednik Taihei Industrial Co., Ltd.</p> <p>Potpis osobe iz EU koja posjeduje Tehnički dokument: G. Neil Roche EMC Menadžer proizvoda TRaC Global Ltd.</p> <p>SERIJSKI BROJ UREĐAJA Datum: 13. ožujka 2012. Certifikat br. 17-0074-1 DofC Broj 3</p>

Norsk (Norwegian)	Türk (Turkish)	Íslenska (Icelandic)
<p>PRODUSENTENS ERKLÆRING OM OVERENSSTEMMELSE For Pantagraph biljekk, modellene PJM700, PJM800, PJM1000 og PJM1200</p> <p>Produsert av Taihei Industrial Co., Ltd Nr. 49-1, Kagekatsu-cho, Fushimi-ku, Kyoto 612-8307 Japan</p> <p>Teknisk fil er satt sammen og lagret i EU, på vegne av produsenten av TRaC Global Ltd 100 Frobisher Business Park, Leigh Sinton Road, Malvern, Worcestershire, WR14 1BX, Storbritannia</p> <p>Veiledende standarder, brukt av maskindirektivet Tillegg 1 for 2006/42/EU med henvisning til: EN 1494:2000/A1:2008</p> <p>Betydningen av overensstemmelse Apparatet er i overensstemmelse med EU-lovverket, slik det er tilnærmet i maskindirektiv 2006/42/EU, Som beskrevet i teknisk dokumentasjonsfil nr. 2136, revisjon 2, fra mars 2012</p> <p>Signatur fra ansvarlig person: Hr. Masato Nasu Direktør Taihei Industrial Co., Ltd.</p> <p>Signatur til person i EU som oppbevarer teknisk fil: Hr. Neil Roche EMC produktsjef TRaC Global Ltd.</p> <p>MASKINENS SERIENR. Dato: 13. mars 2012 Sertifikat nr. 17-0074-1 DoFC utgave 3</p>	<p>AŞAĞIDAKİ ÜRÜNLER İÇİN İMALATÇI UYGUNLUK BEYANI Pantograf Araba Krikosu, Model PJM700, PJM800, PJM1000 ve PJM1200</p> <p>Üretici : Taihei Industrial Co., Ltd No.49-1, Kagekatsu-cho, Fushimi-ku, Kyoto 612-8307 Japonya</p> <p>İmalatçı adına Teknik Dosyayı derleyen ve AB'de muhafaza eden kuruluş TRaC Global Ltd 100 Frobisher Business Park, Leigh Sinton Road, Malvern, Worcestershire, WR14 1BX Birleşik Krallık</p> <p>Yol Gösterici Makine Yönetmeliği olarak kullanılan standartlar EN 1494:2000/A1:2008 no.lu standarda atıfta bulunan 2006/42/EC no.lu Ek I</p> <p>Uyumluluk Aracı Ürün, 2006/42/EC no.lu Makine Yönetmeliği tarafından öngörüldeği şekilde Avrupa Topluluğu yasalarıyla uyumludur, 2136 No.lu 2. Revizyon, 2012 Mart tarihli Teknik Dokümantasyon Dosyasında detaylandırıldığı şekilde</p> <p>Sorumlu Kişinin İmzası: Sayın Masato Nasu Başkan Taihei Industrial Co., Ltd.</p> <p>Teknik Dosyayı AB'de muhafaza eden kişinin imzası: Sayın Neil Roche EMC Ürün Müdürü TRaC Global Ltd.</p> <p>MAKİNE SERİ No. Tarih: 13 Mart 2012 Sertifika No. 17-0074-1 no.lu Uyum Beyanı Yayın 3</p>	<p>YFIRLÝSING FRAMLEIÐANDA UM SAMRÆMI Fyrir Bíla-Skæra Tjakkur, Gerðir PJM700, PJM800, PJM1000 & PJM1200</p> <p>Framleitt af Taihei Industrial Co., Ltd Nr.49-1, Kagekatsu-cho, Fushimi-ku, Kýtótó 612-8307 Japan</p> <p>Tækniskjal tekið saman og notað i ESB, fyrir hönd framleiðanda</p> <p>TRaC Global Ltd 100 Frobisher Business Park, Leigh Sinton Road, Malvern, Worcestershire, WR14 1BX, Bretland</p> <p>Staðlar notaðir sem leiðsögn Tilskipun Vélbúnaðar Viðauki I frá 2006/42/EC með tilvísun til: EN 1494:2000/A1:2008</p> <p>Uppfylling skilyrða Varan uppfyllir lög ESB eins og mælt er fyrir í tilskipun 2006/42/EC um vélarbúnað, Sem tekið er fram í tækniskjali nr. 2136 2. Endurskoðun, mars 2012</p> <p>Undirskrift ábyrgðarmanns: Hr. Masato Nasu Forstjóri Taihei Industrial Co., Ltd.</p> <p>Undirskrift einstaklings í ESB sem heldur um tækniskjalið: Hr. Neil Roche EMC Framleiðslustjóri TRaC Global Ltd.</p> <p>RAÐNÚMER TÆKIS Dagsetning: 13. mars 2012 Númer vottorðs 17-0074-1 DoFC útgáfa 3</p>

-
- א. השימוש במכשיר הינו על בסיס "משני" ופטור מרשיון הפעלה אלחוטי.
כלומר - לא מוגן מהפרעות וללא הפרעה למערכות אחרות הפועלות כדין .
- ב. רק "בפעולת בזק" לשימוש עצמי של הלקוח בלבד, הציוד פטור מרשיון הפעלה אלחוטי.
מתן "שרות בזק" לצד ג' מחייב רשיון מיוחד ממשרד התקשורת.
- ג. אסור להחליף את האנטנה המקורית של המכשיר, ולא לעשות בו כל שינוי טכני אחר.

מספר אישור אלחוטי של משרד התקשורת הוא 51-52240
אסור להחליף את האנטנה המקורית של המכשיר ולא
לעשות בו כל שינוי טכני אחר

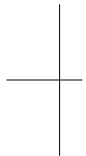
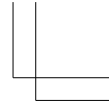
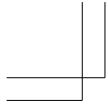

The approval for Ukraine
Blind Spot Warning (BSW) and Rear Cross Traffic Alert (RCTA)



AJMI 06489

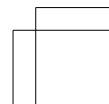
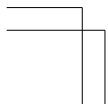

OGGE19E1

Declaration of Conformity 14- 83

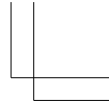
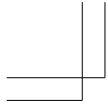

14- 84 Declaration of Conformity

OGGE19E1

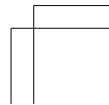
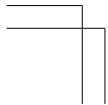

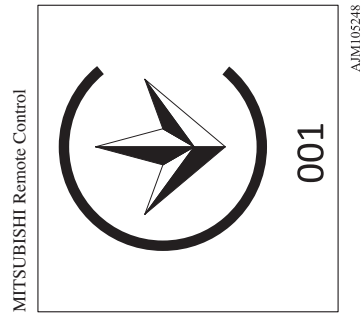
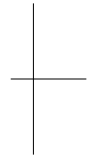
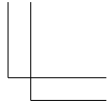
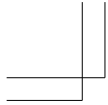

OGGE19E1

Declaration of Conformity 14- 85

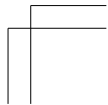
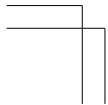

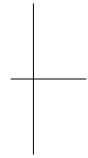
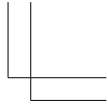
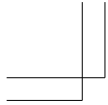

14- 86 Declaration of Conformity

OGGE19E1

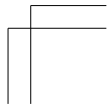
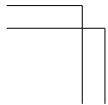

The approval for Serbia
Blind Spot Warning (BSW) and Rear Cross Traffic Alert (RCTA)



AJM105264

OGGE19E1

Declaration of Conformity 14- 87

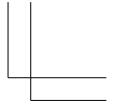
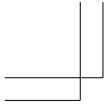

Handwriting practice lines consisting of 12 horizontal dashed lines.

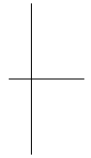
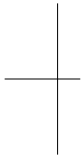

OGGE19E1

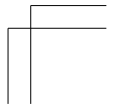
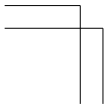

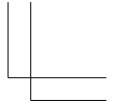
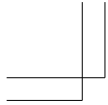

A series of horizontal lines for writing practice, consisting of a solid top line, a dashed midline, and a solid bottom line, repeated multiple times down the page.

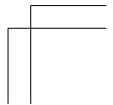
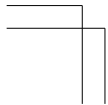
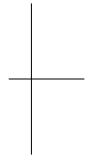
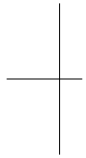

OGGE19E1

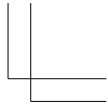
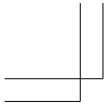

Handwriting practice lines consisting of a solid top line, a dashed midline, and a solid bottom line, repeated 10 times.

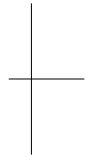
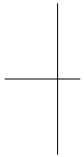

OGGE19E1

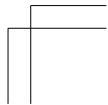
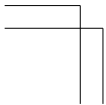

Foreword

E09200107602

Thank you for selecting an OUTLANDER PHEV as your new vehicle.

This owner's manual will add to your understanding and full enjoyment of the many fine features of this vehicle.

It contains information prepared to acquaint you with the proper way to operate and maintain your vehicle for the utmost in driving pleasure.

MITSUBISHI MOTORS Europe B.V. reserves the right to make changes in design and specifications and/or to make additions to or improvements in this product without obligation to install them on products previously manufactured.

It is an absolute requirement for the driver to strictly observe all laws and regulations concerning vehicles.

This owner's manual has been written in compliance with such laws and regulations, but some of the contents may become contradictory with later amendment of the laws and regulations.

Please leave this owner's manual in this vehicle at time of resale. The next owner will appreciate having access to the information contained in this owner's manual.

Repairs to your vehicle:

Vehicles in the warranty period:

All warranty repairs must be carried out by a MITSUBISHI MOTORS Authorized Service Point.

Vehicles outside the warranty period:

Where the vehicle is repaired is at the discretion of the owner.

Throughout this owner's manual the words **WARNING** and **CAUTION** appear. These serve as reminders to be especially careful. Failure to follow instructions could result in personal injury or damage to your vehicle.

WARNING

Indicates a strong possibility of severe personal injury or death if instructions are not followed.

CAUTION

Means hazards or unsafe practices that could cause minor personal injury or damage to your vehicle.

NOTE

Gives helpful information.

***: Gives helpful information.**

It may differ according to the sales classifications; refer to the sales catalogue.

Abbreviations used in this owner's manual:

LHD: Left-Hand Drive

RHD: Right-Hand Drive

The symbol used on the vehicles:



: See owner's manual

Information for station service

E09300104543

Fuel	Fuel tank capacity	45 litres
	Recommended fuel	Unleaded petrol octane number (EN228) 95 RON or higher Refer to the "General Information" section for the fuel selection.
Engine oil		Refer to the "Maintenance" section for the selection of engine oil.
Tyre inflation pressure		Refer to the "Maintenance" section for the tyre inflation pressure.

 **MITSUBISHI MOTORS Europe B.V.**

© 2018 Mitsubishi Motors Corporation

OGGE19E1
BLO-18-000312

19