



# 2013 Audi Q7

## Owner's Manual

Audi  
Vorsprung durch Technik





## **Introduction**

**Thank you for choosing an Audi - we value your trust in us.**

Your new Audi incorporates the newest technology as well as numerous features designed for your comfort, convenience and safety. We recommend you read your Owner's Manual thoroughly so that you can quickly become acquainted with your Audi.

In addition to explaining how the different features work, we also give you many useful tips and information concerning your safety and that of your passengers, how to care for your vehicle and maintain your vehicle's value.

We hope you enjoy driving your Audi and we wish you safe and pleasant motoring.

**AUDI AG**



1315614L023

|  |    |   |     |
|--|----|---|-----|
| <b>Vehicle literature</b> .....                            | 5  | Luggage compartment .....   | 79  |
| <b>About this Owner's Manual</b> ...                       | 6  | Roof rack .....   | 83  |
| <b>Controls and equipment</b> .....                        | 8  | Cupholder .....   | 85  |
| <b>Instruments and controls</b> .....                      | 8  | Rear ashtray .....  | 86  |
| General illustration .....                                 | 8  | Outlet .....  | 87  |
| <b>Instruments and warning/<br/>indicator lights</b> ..... | 10 | Storage .....   | 87  |
| Instruments .....  | 10 | <b>Warm and cold</b> .....  | 91  |
| Warning/indicator lights .....                             | 14 | Climate control .....   | 91  |
| <b>Driver information display</b> .....                    | 21 | Rear Air Conditioning .....                                       | 97  |
| Introduction .....   | 21 | Basic settings .....  | 99  |
| Trip computer .....  | 24 | Heated Seats .....  | 100 |
| Efficiency program .....                                   | 26 | <b>On the road</b> .....  | 103 |
| On-Board Diagnostic system (OBD) ...                       | 27 | Steering .....  | 103 |
| Electronic speed limiter .....                             | 28 | Ignition lock and ignition switch .....                           | 105 |
| Speed warning system .....                                 | 28 | Starting and stopping the engine .....                            | 106 |
| Auto Check Control .....                                   | 30 | Starting and stopping the engine with<br>Convenience key .....    | 107 |
| <b>Opening and closing</b> .....                           | 38 | Parking brake .....   | 109 |
| Keys .....   | 38 | Starting on hills .....   | 110 |
| Power locking system .....                                 | 41 | Cruise control .....  | 111 |
| Rear lid .....   | 45 | <b>Adaptive cruise control</b> .....                              | 113 |
| Child safety lock .....                                    | 48 | Speed and distance control system ..                              | 113 |
| Convenience key .....                                      | 49 | Driver information .....  | 120 |
| Anti-theft alarm system .....                              | 50 | System limitations .....  | 125 |
| Power windows .....  | 51 | Audi braking guard .....  | 127 |
| Panoramic sliding sunroof .....                            | 54 | <b>Audi side assist</b> .....                                     | 129 |
| <b>Clear vision</b> .....                                  | 57 | Lane Change Assistant .....                                       | 129 |
| Lights .....   | 57 | Notes .....   | 135 |
| Interior lights .....                                      | 61 | <b>Automatic transmission</b> .....                               | 137 |
| Vision .....   | 62 | tiptronic <sup>®</sup> .....                                      | 137 |
| Wiper and washer system .....                              | 63 | <b>Parking systems</b> .....                                      | 143 |
| Mirrors .....  | 68 | General information .....   | 143 |
| Digital compass .....                                      | 69 | Rear park assist .....  | 144 |
| <b>Seats and storage</b> .....                             | 71 | Audi parking system plus with<br>rearview camera .....            | 144 |
| General recommendations .....                              | 71 | Audi parking system plus with front-<br>and rearview camera ..... | 148 |
| Power front seat adjustment .....                          | 72 | Adjusting the display and warning<br>tones .....                  | 153 |
| Seat memory .....  | 73 | Error messages .....  | 153 |
| Rear seats .....   | 74 | Trailer hitch .....   | 153 |
| Head restraints .....                                      | 76 |   |     |
| Armrest .....  | 77 |   |     |
| Long center console .....                                  | 78 |   |     |

|   |     |  |     |
|---|-----|--|-----|
| <b>Adaptive Air Suspension</b> . . . . .                        | 155 | <b>Driving and environment</b> . . . . .                           | 234 |
| Air suspension and damping . . . . .                            | 155 | The first 1,000 miles (1,500 km) and afterwards . . . . .          | 234 |
| <b>HomeLink®</b> . . . . .                                      | 161 | Catalytic converter . . . . .                                      | 235 |
| Universal remote control . . . . .                              | 161 | Diesel particulate filter . . . . .                                | 235 |
| <b>Safety first</b> . . . . .                                   | 165 | Avoid damaging the vehicle . . . . .                               | 236 |
| <b>Driving Safely</b> . . . . .                                 | 165 | Operate your vehicle economically and minimize pollution . . . . . | 236 |
| General notes . . . . .   | 165 | <b>Driving off road</b> . . . . .                                  | 238 |
| Proper occupant seating positions . . . . .                     | 166 | Driving in difficult road conditions and offroad . . . . .         | 238 |
| Pedal area . . . . .  | 170 | <b>Trailer towing</b> . . . . .                                    | 241 |
| Stowing luggage . . . . .                                       | 171 | Driving with a trailer . . . . .                                   | 241 |
| Reporting Safety Defects . . . . .                              | 172 | Trailer towing tips . . . . .                                      | 243 |
| <b>Safety belts</b> . . . . .                                   | 175 | <b>Vehicle care</b> . . . . .                                      | 245 |
| General notes . . . . .   | 175 | <b>Cleaning and protection</b> . . . . .                           | 245 |
| Why safety belts? . . . . .                                     | 176 | General information . . . . .                                      | 245 |
| Safety belts . . . . .  | 179 | Care of exterior . . . . .   | 245 |
| Safety belt pretensioners . . . . .                             | 182 | Care of interior . . . . .   | 251 |
| <b>Airbag system</b> . . . . .                                  | 184 | <b>Fuel supply and filling your fuel tank</b> . . . . .            | 256 |
| Important things to know . . . . .                              | 184 | Fuel supply . . . . .  | 256 |
| Front airbags . . . . .   | 188 | Diesel fuel . . . . .  | 257 |
| Monitoring the Advanced Airbag System . . . . .                 | 195 | Fuel tank . . . . .  | 258 |
| Side airbags . . . . .  | 199 | Selective catalytic reduction . . . . .                            | 261 |
| Side curtain airbags . . . . .                                  | 202 | <b>Checking and filling</b> . . . . .                              | 264 |
| <b>Child Safety</b> . . . . .                                   | 205 | Engine hood . . . . .  | 264 |
| Important things to know . . . . .                              | 205 | Engine oil . . . . .   | 266 |
| Child safety seats . . . . .                                    | 211 | Engine cooling system . . . . .                                    | 271 |
| Installing a child safety seat . . . . .                        | 215 | Brake fluid . . . . .  | 274 |
| LATCH Lower anchorages and tethers for children . . . . .       | 218 | Battery . . . . .  | 275 |
| Additional Information . . . . .                                | 224 | Windshield/headlight washer container . . . . .                    | 279 |
| <b>Vehicle operation</b> . . . . .                              | 225 | <b>Tires and wheels</b> . . . . .                                  | 280 |
| <b>Intelligent technology</b> . . . . .                         | 225 | Tires . . . . .  | 280 |
| Notice about data recorded by vehicle control modules . . . . . | 225 | Tire pressure monitoring system . . . . .                          | 298 |
| Electronic Stabilization Control (ESC) . . . . .                | 225 | <b>Do-it-yourself service</b> . . . . .                            | 301 |
| Braking . . . . .   | 228 | <b>What do I do now?</b> . . . . .                                 | 301 |
| Servotronic® - advanced power steering system . . . . .         | 230 | Jack, tools and inflatable spare tire . . . . .                    | 301 |
| Driving with your quattro® . . . . .                            | 231 | Changing a wheel . . . . .   | 304 |
| Energy management . . . . .                                     | 231 |  |     |

---

|  |            |
|--|------------|
| <b>Fuses and bulbs</b> .....   | <b>309</b> |
| Electrical fuses .....   | 309        |
| Bulbs .....  | 312        |
| <b>Emergency situations</b> .....  | <b>314</b> |
| General .....  | 314        |
| Starting by pushing or towing .....  | 314        |
| Starting with jumper cables .....  | 314        |
| Use of jumper cables .....   | 315        |
| Emergency towing with commercial<br>tow truck .....                              | 316        |
| Lifting vehicle .....  | 318        |
| <b>Technical data</b> .....  | <b>320</b> |
| <b>General information</b> .....   | <b>320</b> |
| Explanation of technical data .....  | 320        |
| Vehicle identification .....   | 320        |
| Weights .....  | 320        |
| Dimensions .....   | 321        |
| <b>Data</b> .....  | <b>322</b> |
| 280 hp, 6-cylinder engine, with all-<br>wheel drive .....                        | 322        |
| 333 hp, 6-cylinder engine, with all-<br>wheel drive .....                        | 323        |
| 240 hp, 6-cylinder engine, with all-<br>wheel drive .....                        | 324        |
| <b>Consumer Information</b> .....  | <b>325</b> |
| Warranty coverages .....   | 325        |
| Operating your vehicle outside the<br>U.S.A. or Canada .....                     | 325        |
| Audi Service Repair Manuals and<br>Literature .....                              | 325        |
| Maintenance .....  | 325        |
| Additional accessories, modifications<br>and parts replacement .....             | 327        |
| Declaration of Compliance,<br>Telecommunications and Electronic<br>Systems ..... | 328        |
| <b>Index</b> .....   | <b>330</b> |

In addition to this Owner's Manual, your Audi comes with the

- MMI Operating Instructions
- Warranty & Maintenance booklet.

If you are missing one of these publications, or if you believe that the information is not complete, contact your authorized Audi dealer for assistance.

### **MMI Operating Instructions**

contain detailed description of the Audi Multi Media Interface (MMI) including the navigation system, the sound system and the hand-held phone.

### **The Warranty & Maintenance booklet**

explains how you can keep your Audi in top driving condition by having it serviced regularly and contains detailed information about the warranties covering your Audi. Always have the booklet with you when you take your vehicle to an authorized Audi dealer for service. Your Audi Service Advisor will record each scheduled service and can answer any questions you may have regarding how to maintain your vehicle.

### **In Canada,**

the vehicle literature is also available in French. To obtain a copy, contact your dealer or write to:

Au Canada, on peut se procurer un exemplaire en français de ce document auprès du concessionnaire ou de:

Volkswagen Canada, Inc.  
Client Assistance  
Assistance a la Clientele  
777 Bayly Street, West,  
Ajax, Ontario L1S 7G7

### **If you sell your Audi**

all literature should be left in the vehicle to make the Warranty terms as well as all operating, safety and maintenance information available to the next owner.

### **If you change your address or if you bought this Audi used**

be sure to send in a "Notice of Address Change" / "Notice of Used Car Purchase" post card. This card can be found in the Warranty & Maintenance booklet or obtained from your authorized Audi dealer.

**It is in your own interest that we are able to contact you should the need arise.**

This owner's manual contains important information, tips, suggestions, and warnings for the use of your vehicle.

Make sure that this owner's manual is always located in the vehicle. This is especially important if you allow other people to drive the vehicle, or if you sell it.

This owner's manual describes the **equipment range** specified for this model at the editorial deadline date. Some of the equipment described here will only be available at a later date, or only in specific markets.

Some sections in this owner's manual do not apply to all vehicles. In that case, the **range of applicability** is given at the beginning of the section, e. g. "Applies to vehicles: with adaptive light". In addition, optional equipment is indicated by an asterisk "\*".

The details in the **illustrations** may be different from those in your vehicle, and are intended to be viewed as a basic guide.

You will find a **table of contents** at the beginning of this book, which displays all topics described in this manual in order of appearance. You will find an alphabetical **index** at the end of this book.

All **directions**, such as "left", "right", "front", "back", are relative to the direction of travel.

- \* optional equipment
- ▶ This section continues on the next page.
- ® Registered trademarks are identified with a ®. If this symbol is missing, it is no guarantee that the terms can be used freely.

⇒ ⚠ Cross-reference to a "WARNING!" within a section. For indication with a page number, the corresponding "WARNING!" can be found outside of the section.

### WARNING

Text with this symbol contains important information on safety and how to reduce the risk of personal injury or death.

### Note

Text with this symbol draws your attention to potential sources of damage to your vehicle.

### For the sake of the environment

Text with this symbol contains information about the environment and how you can help protect it.

### Tips

Text with this symbol contains special tips and other information about getting the most out of your vehicle and its features.



## Instruments and controls

### General illustration

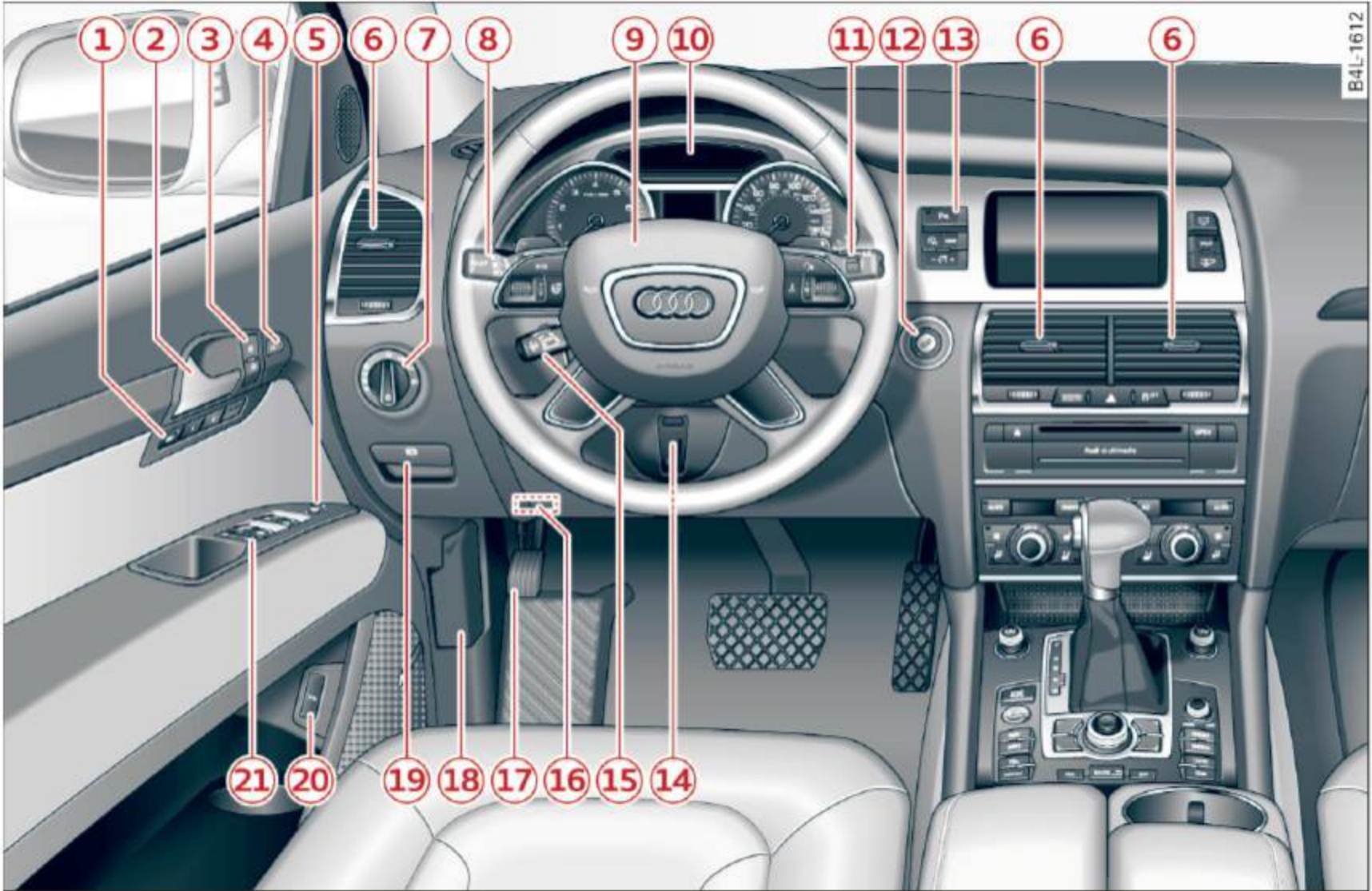

Fig. 1 Cockpit: left section

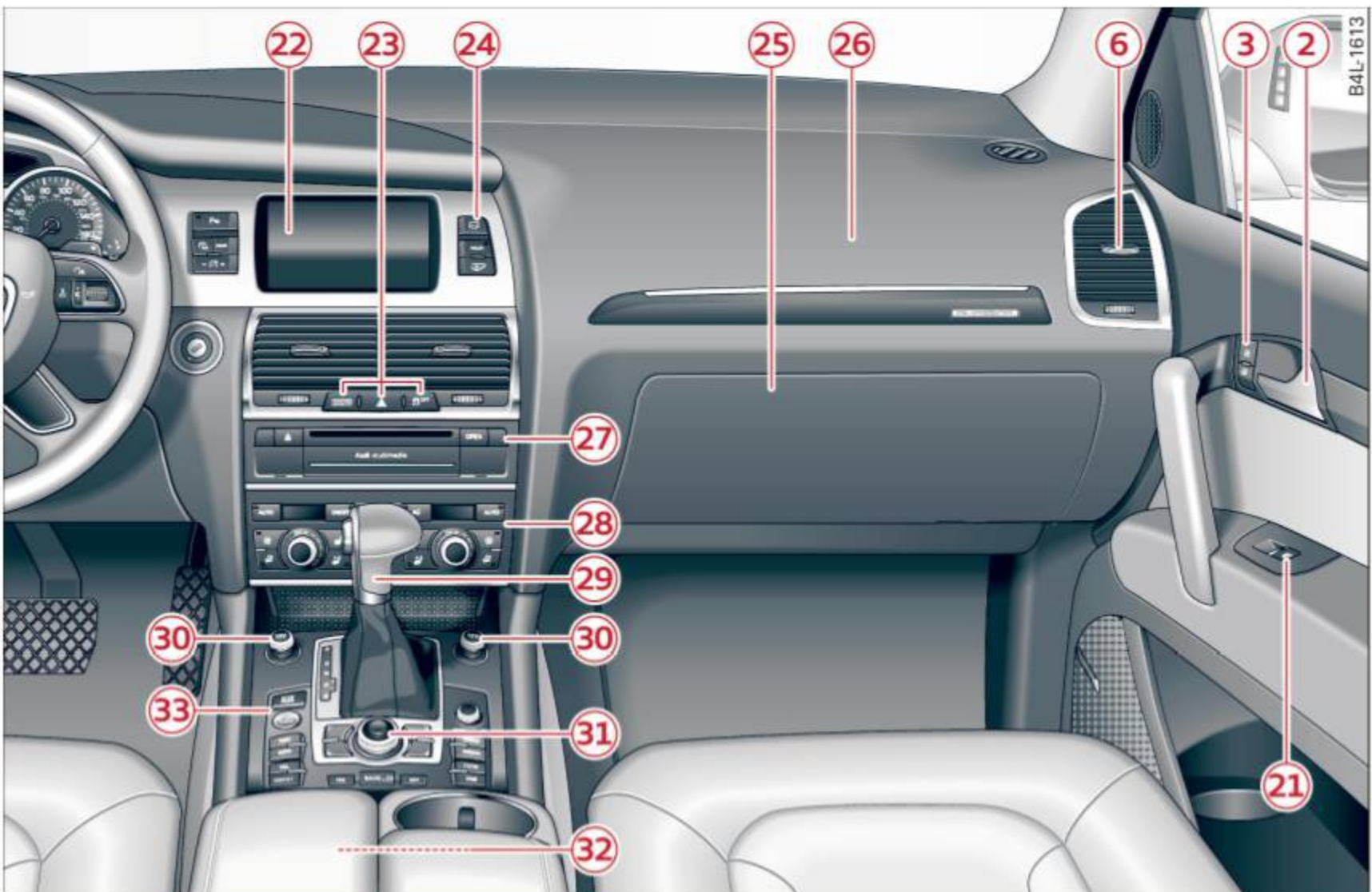

Fig. 2 Cockpit: right section

|   |  |     |    |  |     |
|---|--|-----|----|--|-----|
| ① | Memory buttons (driver's seat)                                     | 73  | ②① | Power window switches . . . . .                    | 51  |
| ② | Door handle  |     | ②② | MMI Display (see separate manual)                  |     |
| ③ | Power locking switch . . . . .                                     | 44  | ②③ | Buttons/Indicator light for:                       |     |
| ④ | Side assist button . . . . .                                       | 129 |    | – PASSENGER AIR BAG OFF                            |     |
| ⑤ | Adjuster control for outside mirrors . . . . .                     | 68  |    | – Emergency flashers . . . . .                     | 60  |
| ⑥ | Air outlets . . . . .  | 96  |    | – Electronic Stabilization Control (ESC) . . . . . | 225 |
| ⑦ | Light switch . . . . .   | 57  | ②④ | Buttons for:                                       |     |
| ⑧ | Turn signal and high beam . . . . .                                | 60  |    | – Switching MMI display on/off                     |     |
| ⑨ | Multifunction steering wheel with:                                 |     |    | – Valet key function . . . . .                     | 41  |
|   | – Horn   |     |    | – Unlocking glove compartment                      | 88  |
|   | – Driver's airbag . . . . .  | 188 | ②⑤ | Glove compartment . . . . .                        | 88  |
|   | – Audio/video, telephone, navigation and voice recognition buttons |     | ②⑥ | Front passenger's airbag . . . . .                 | 188 |
|   | – Shift buttons . . . . .  | 141 | ②⑦ | Audi multimedia (see separate manual)              |     |
|   | – Button for steering wheel heating . . . . .                      | 101 | ②⑧ | Climate controls . . . . .                         | 92  |
| ⑩ | Instrument cluster . . . . .                                       | 10  | ②⑨ | Shift lever for automatic transmission . . . . .   | 137 |
| ⑪ | Switches for:  |     | ③⑩ | 12-volt outlets . . . . .                          | 87  |
|   | – Windshield wiper/washer . . . . .                                | 63  | ③① | MMI control console (see separate manual)          |     |
|   | – Trip computer . . . . .  | 24  | ③② | Storage compartment                                |     |
| ⑫ | Ignition lock . . . . .  | 105 | ③③ | <b>START</b> -/ <b>STOP</b> button . . . . .       | 107 |
| ⑬ | Buttons for:   |     |    |  |     |
|   | – Parking system . . . . .   | 144 |    |  |     |
|   | – Resetting the trip odometer . . . . .                            | 12  |    |  |     |
|   | – <b>CHECK</b> button . . . . .                                    | 12  |    |  |     |
|   | – Instrument lighting . . . . .                                    | 13  |    |  |     |
| ⑭ | Adjustable steering wheel, depending on equipment:                 |     |    |  |     |
|   | – mechanical . . . . .   | 103 |    |  |     |
|   | – electrical . . . . .   | 103 |    |  |     |
| ⑮ | Control lever for:   |     |    |  |     |
|   | – Cruise control . . . . .   | 111 |    |  |     |
|   | – Adaptive cruise control . . . . .                                | 113 |    |  |     |
| ⑯ | Data Link Connector for On Board Diagnostics (OBD II) . . . . .    | 27  |    |  |     |
| ⑰ | Pedal for operating parking brake . . . . .                        | 109 |    |  |     |
| ⑱ | Engine hood release . . . . .                                      | 264 |    |  |     |
| ⑲ | Handle for releasing parking brake . . . . .                       | 109 |    |  |     |
| ⑳ | Switch for unlocking the trunk lid . . . . .                       | 45  |    |  |     |

### **i** Tips

Some of the equipment or features shown in the general illustration may be standard equipment on your vehicle or may be optional equipment depending on your model. Always ask your authorized Audi dealer if you have a question about your vehicle.

# Instruments and warning/indicator lights

## Instruments

### Instrument cluster and controls

The instrument cluster is your central source of information.

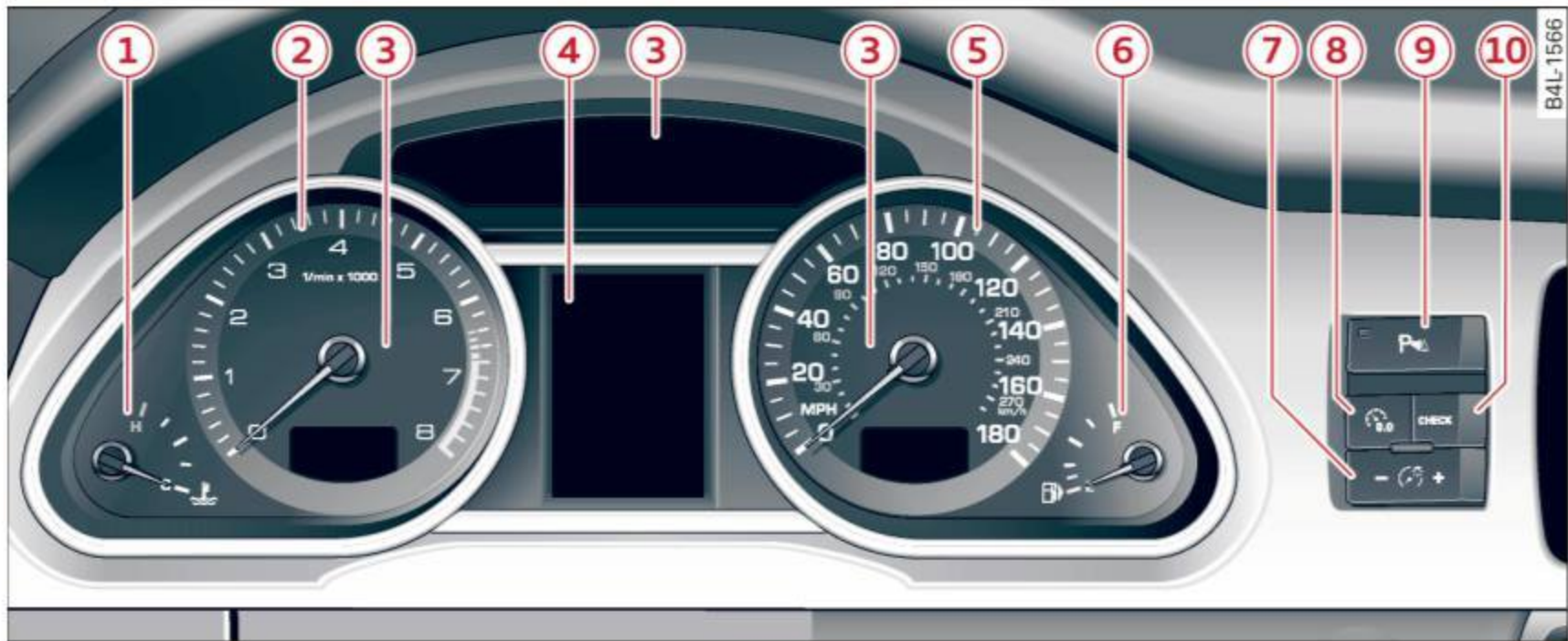

Fig. 3 Overview of the instrument cluster

|   |   |        |
|---|---|--------|
| ① | Coolant temperature gauge . . .                 | 10     |
| ② | Tachometer with time and date display . . . . . | 11, 11 |
| ③ | Warning/indicator lights . . . . .              | 14     |
| ④ | Driver information system . . . . .             | 21     |
| ⑤ | Speedometer with odometer . .                   | 12     |
| ⑥ | Fuel gauge . . . . .                            | 12     |
| ⑦ | Instrument cluster illumination                 | 13     |
| ⑧ | Reset button for trip odometer .                | 12     |
| ⑨ | Parking system . . . . .                        | 144    |
| ⑩ | <b>CHECK</b> button . . . . .                   | 12     |

**i Tips**  
 The illumination for the instrument cluster lights up whenever you switch on the ignition with the **vehicle headlights off**. As the daylight fades, the instrument cluster illumination likewise dims automatically and will go out completely when the outside light is very low. This feature is meant to remind you to switch on the headlights when outside light conditions become poor.

### Engine coolant temperature gauge

The engine coolant gauge ⇨ *page 10, fig. 3 ①* only works when the ignition is on. To prevent damage to your engine, please note the following important points:

#### Engine cold

As long as the needle remains at or close to the bottom of the gauge, the engine still has not reached its operating temperature. Avoid high engine speeds, heavy engine loads and heavy throttle applications.

#### Normal temperature

When the engine has reached its operating temperature, the needle will move into the middle of the gauge and remain there. If the engine is working hard at high outside temperatures, the needle may rise up. This is no need to worry as long as the  warning light in the instrument cluster does not illuminate.

#### Warning light in the instrument cluster

When the  warning light in the instrument cluster starts to flash, this can mean one of two things: either the coolant *temperature* is

too high, or the coolant *level* is too low  
⇒ page 32.

If the needle is well in the upper area of the gauge, the coolant temperature is too high. **Stop the vehicle, switch the engine off and allow the engine to cool.** If the warning light comes on again after driving a short distance, contact an authorized dealer.

### WARNING

- Always observe the warning in  
⇒ page 255, *Engine compartment*, before opening the hood and checking the engine coolant level.
- Never open the engine hood if you see or hear steam, or if you see engine coolant dripping from the engine compartment. You could burn yourself. Let the engine cool off first until you can no longer see or hear steam or coolant escaping.

### Note

- Mounting additional lights or accessories in front of the air inlets reduces the cooling effect of the radiator. At high outside temperatures or high engine load, the engine could overheat.
- The front spoiler has been designed to properly distribute the cooling air when the vehicle is moving. If the spoiler is damaged, this could reduce the cooling effect and the engine could then overheat. Ask your authorized Audi dealer for assistance.

## Tachometer (engine rev counter)

The tachometer indicates the engine RPM (revolutions per minutes).

The tachometer  ⇒ page 10, fig. 3 is the left of the two large clock-type displays.

The engine turns at a speed *1,000 times* the single digit in the display, e.g. if the needle is pointing at the “2” the engine is turning at 2,000 RPM.

If engine RPM drops below 1,500, you should downshift to the next lower gear. The red area at the end of the scale indicates maximum permissible engine RPM after the break-in period. Before reaching this area, move the selector lever to position “D (Drive)” or ease your foot off the accelerator pedal.

### Note

The tachometer needle should not move into the red range. If it does, then only for a very short period of time. You could damage your engine by driving at high RPM.

### For the sake of the environment

Upshifting early saves fuel and reduces engine noise.

## Digital clock with date display



Fig. 4 Instrument cluster: time and date

The date, time of day, and time and date format can be set in the MMI. You can learn more about this in the MMI manual.

### Tips

- When open the driver door, the time, date and odometer are displayed for an additional 30 seconds.
- You can also call up the display with the **CHECK** button ⇒ page 12 while the ignition is switched off.

### Speedometer with odometer

The speedometer shows you the vehicle speed, and the odometer shows you how many miles (kilometers) you have driven.



Fig. 5 Instrument cluster Odometer and reset button

The odometer and trip odometer are located inside the speedometer.

- USA models – Miles
- Canada models – Kilometers

You can switch the display from miles to kilometers and vice versa via the MMI. You can find out more in the MMI manual.

#### Lower odometer

The lower odometer shows the total number of miles (kilometers) driven.

#### Upper odometer (trip odometer)

The upper odometer shows the total number of miles (kilometers) driven since you last reset the odometer to zero. You can use this odometer when you want to keep track of how many miles (kilometers) you have driven for a single trip or errand. The last digit indicates 1/10 of a mile (100 meters).

You can reset the trip odometer to zero by pressing the Reset button .

#### Malfunction message

If there is a malfunction somewhere in the instrument cluster, **dEF** will appear in the trip odometer and will stay on. Contact your authorized Audi dealer to have the problem corrected.

### Tips

- When you open the driver door, the time, date and odometer are displayed for an additional 30 seconds.
- You can also call up the display with the **CHECK** button  $\Rightarrow$  page 12 while the ignition is switched off.

### Fuel gauge

The fuel gauge only works when the ignition is on.

When the needle reaches the reserve mark, the  $\Rightarrow$  page 35  symbol appears in the instrument cluster display as well as the message **Please refuel**. This message is meant to remind you to **refuel**.

The total tank capacity of your vehicle is listed in  $\Rightarrow$  page 322.

### Note

Never run the tank completely dry. An irregular supply of fuel can cause engine misfiring and fuel could enter the exhaust system. The catalytic converter could then overheat and be damaged.

### **CHECK** button

You can perform different functions with this button.



Fig. 6 CHECK button in the instrument cluster

The **CHECK** button performs the following functions:

### Switching on the clock and odometer

With the ignition turned off, the odometer reading and the digital clock with date display can be switched on for about 30 seconds by pressing the **CHECK** button ⇒ *fig. 6*.

### Starting the Auto-Check sequence

The Auto-Check system ⇒ *page 30* constantly monitors certain individual functions and components of the vehicle when the ignition is turned on and when the vehicle is moving.

With the ignition turned on, you can start the "Auto-Check sequence" by pressing the **CHECK** button. You can perform an Auto-Check sequence when the vehicle is stationary and the ignition is turned on or when the vehicle is moving not faster than 3 mph (5 km/h).

The number of keys programmed to the vehicle is also displayed. The display **3\3** indicates that three keys have been programmed. This allows you to make sure you have received all of the keys when you purchase a used vehicle.

For example, if you only receive two keys, you should take those keys to your authorized Audi dealer to have the missing key deactivated so it cannot be used. You should also report the missing key to your insurance company.

### Calling up the driver information

A yellow or red symbol appears in the instrument cluster display, usually with a driver message. The driver message display disappears after about 5 seconds. The driver message can be displayed again by briefly pressing the **CHECK** button.

### Setting the speed warning

By pressing the **CHECK** button briefly, you can set threshold 1 of the speed warning

while you are driving ⇒ *page 29*. By maintaining pressure on the **CHECK** button, you delete the warning threshold.

### Instrument cluster illumination

*The basic brightness of the illumination for the instruments, the center console and the display can be adjusted.*



**Fig. 7** Instrument cluster illumination

- ▶ Press the "+" button to increase the brightness during the hours of darkness.
- ▶ Press the "-" button to decrease the brightness during the hours of darkness.

A light sensor in the instrument cluster controls the illumination for the instrument cluster, the center console and the displays. In a bright environment, using the buttons to change the brightness has no effect.

### **i** Tips

The illumination for the instrument cluster lights up whenever you switch on the ignition with the vehicle headlights off. As the daylight fades, the instrument cluster illumination likewise dims automatically and will go out completely when the outside light is very low. This feature is meant to remind you to switch on the headlights when outside light conditions become poor.

# Warning/indicator lights

## Overview

The warning/indicator lights indicate different functions or a possible malfunction.







Fig. 8 Instrument cluster with warning/indicator lights



Your vehicle is equipped with several important warning and indicator lights to help you monitor the continued reliable operation of your vehicle ⇒ ⚠.

|  |  |
|--|--|
|  | Electronic power control (alternative to )<br>⇒ page 15    |
|  | Glow plug system (alternative to <b>EPC</b> )<br>⇒ page 15 |
|  | Electronic Stabilization Control (ESC)<br>⇒ page 16        |
|  | Electronic Stabilization Control (ESC)<br>⇒ page 16        |
|  | <b>USA models:</b> Safety systems<br>⇒ page 16             |
|  | <b>Canada models:</b> Safety systems<br>⇒ page 16          |
|  | Left turn signal<br>⇒ page 16                              |
|  | Trailer turn signal assembly*<br>⇒ page 16                 |

|  |  |
|--|--|
|  | Malfunction Indicator Lamp (MIL)<br>⇒ page 17                          |
|  | Adaptive Air Suspension*<br>⇒ page 17                                  |
|  | Adaptive Air Suspension*<br>⇒ page 17                                  |
|  | Right turn signal<br>⇒ page 16   |
|  | Safety belt<br>⇒ page 18   |
|  | High beam<br>⇒ page 18   |
|  | Tire pressure monitoring system<br>⇒ page 18                           |
|  | <b>USA models:</b> Cruise control activated<br>⇒ page 18               |
|  | <b>Canada models:</b> Cruise control activated<br>⇒ page 18            |
|  | <b>USA models:</b> Anti-lock brake system (ABS) defective<br>⇒ page 18 |

|   |   |
|---|---|
|  | <b>Canada models:</b> Anti-lock brake system (ABS) defective<br>⇒ page 18 |
|  | <b>USA models:</b> Parking brake<br>⇒ page 19                             |
|  | <b>Canada models:</b> Parking brake<br>⇒ page 19                          |
|  | <b>USA models:</b> Brake malfunction<br>⇒ page 19                         |
|  | <b>Canada models:</b> Brake malfunction<br>⇒ page 19                      |

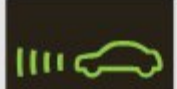
Vehicles with the adaptive cruise control\* have the following additional check lamps:

|   |  |
|---|--|
|  | Open road<br>⇒ page 121                            |
|  | Driving in traffic<br>⇒ page 121                   |
|  | Request for driver to assume control<br>⇒ page 121 |

### WARNING

- Failure to heed warning lights and other important vehicle information may result in serious personal injury or vehicle damage.
- Whenever stalled or stopped for repair, move the vehicle a safe distance off the road, stop the engine, and turn on the emergency flasher ⇒ page 60.
- The engine compartment of any motor vehicle is a potentially hazardous area. Before you check anything in the engine compartment, stop the engine and let it cool down. Always exercise extreme caution when working under the hood ⇒ page 255, *Engine compartment*.

### Tips

Many functions are monitored by the Auto-Check system ⇒ page 30. Malfunctions or faults will be identified either with a red

symbol (priority 1 – Danger!) or with a yellow symbol (priority 2 – Warning).

### EPC Electronic power control

Applies to vehicles: with gasoline engine

*This warning/indicator light monitors the electronic power control.*

The **EPC** warning/indicator light (Electronic Power Control) illuminates when you turn on the ignition as a function check.

### Tips

If this warning/indicator light illuminates while you are driving, then there is a malfunction in the engine electronics. Have the malfunction corrected as soon as possible by your authorized Audi dealer or qualified workshop.

### Glow plug system

Applies to vehicles: with diesel engine

*The control light illuminates when the glow plug system is active.*

If the  indicator light illuminates, the glow plug system is active. You should start the engine immediately after the indicator light switches off. The indicator light only illuminates for approximately 1 second if the engine is warm or if the outside temperature is above 46 °F (8 °C).

### Tips



- If the glow plug indicator light illuminates while driving, there is an engine control malfunction. The engine should be checked immediately.
- If the indicator light does not illuminate at all when switching the ignition on, there may be a malfunction in the glow plug system. The engine should be checked.

## Electronic Stabilization Control (ESC)



*This warning/indicator light monitors the Electronic Stabilization Control.*

If the  indicator lamp blinks while driving, the ESC or ASR (Anti-Slip Regulation) is actively regulating.

If the  indicator lamp illuminates, the system has switched the ESC off. In this case, you can switch the ignition off and then on to switch the ESC on again. The system is functioning completely when the indicator lamp switches off.

If the  indicator lamp illuminates, the ESC was switched off with the  button.



**Stabilization control (ESC/ABS): Fault! See owner's manual**



If the  indicator lamp and the  ABS indicator lamp illuminate and the driver message appears, the ABS or electronic differential lock is malfunctioning. This also interrupts the ESC. The brakes still function with their normal power, but ABS is not active.

Drive to your authorized Audi dealer immediately to have the malfunction corrected.

For more information about the ESC  
⇒ page 225.

## Safety systems

The  (USA models) /  (Canada models) indicator light monitors the safety systems (e.g. airbags, pretensioners) and illuminates for a few seconds each time you switch the ignition on.



If the  (USA models) /  (Canada models) indicator light does not go out, or if it illuminates while you are driving, or if it starts to blink, then there is a malfunction somewhere in the system. If the light does not illuminate when you switch the ignition on, this also means there is a malfunction.

## WARNING

If you have a malfunction in the safety systems, contact your authorized Audi dealer immediately. Otherwise the safety systems may not work properly in an accident.

## Turn signals

*The indicator light blinks when you use either turn signal.*

Whenever you use the left  or the right  turn signal, the indicator light blinks. When you use the emergency flashers, both indicator lights flash.

If one of the turn signal light bulbs burn out, the turn signal will blink twice as fast as normal.

This does not apply, however, in towing mode. The indicator light does not flash if a turn signal is out on the trailer or the towing vehicle. Additional information on the turn signals  
⇒ page 60.

## Trailer turn signal assembly

Applies to vehicles: with towing hitch

*The indicator light also blinks if the turn signal is operated when towing a trailer.*

The indicator light  blinks when the turn signal is used, if a trailer has been properly connected to the vehicle.

If one of the turn signal bulbs on the trailer is burned out or defective, the indicator light will not blink when you use the turn signals.

## Tips

For vehicles with a factory installed towing hitch or a trailer hitch that was installed later according to factory specifications, the trailer turn signal assembly is actuated.

### Malfunction Indicator Lamp (MIL)

The Malfunction Indicator Lamp (MIL) is part of the On-Board Diagnostic (OBD II) system. The symbol  lights up when the ignition is turned on and will turn off after the engine has started and has settled at a constant idle speed. This indicates that the MIL is working properly.

The warning light illuminates when there is a malfunction in the engine electronic system. Contact your authorized Audi dealer and have the malfunction corrected.

**An improperly closed fuel filler cap may also cause the MIL light to illuminate (only vehicles with gasoline engine)** ⇒ page 259.

For more information ⇒ page 27.

### Adaptive Air Suspension

Applies to vehicles: with Adaptive Air Suspension

This  warning/indicator light has the following functions:

- It illuminates for a few seconds after the ignition is turned on as function check and then goes out.
- If the warning/indicator light illuminates or blinks continuously, there is a system fault in the Adaptive Air Suspension. A system fault can result in limited ride comfort and **low ground clearance**. Drive safely to the nearest authorized Audi dealer or qualified workshop, and have the fault corrected.
- If the warning/indicator light flashes, you should not drive the vehicle. The flashing warning/indicator light points to an extreme High level. A very *pronounced lifting* of the vehicle (extreme High level) can result, for example, when a heavy load is removed from the vehicle. As soon as the level has returned to normal, the warning/indicator light stops flashing, and you can drive away.
- If the warning/indicator light flashes in conjunction with the  warning/indicator light, you should not drive off immediately in order to prevent damage to the underbody. The two warning/indicator lights

flashing together points to an extreme Low level. A very *pronounced lowering* of the vehicle (extreme Low level) can result, for example, from a heavy load. As soon as the level has returned to normal, the warning/indicator lights stop flashing, and you can drive away.

#### Note

If the warning/indicator light flashes in conjunction with the  warning/indicator light, you should not drive the vehicle because low-lying vehicle parts can bottom out as you drive over uneven ground and be damaged as a result.

### Adaptive Air Suspension

Applies to vehicles: with Adaptive Air Suspension

This  warning/indicator light has the following functions:

- It illuminates for a few seconds after the ignition is turned on as function check and then goes out.
- It comes on for approximately 15 seconds as a warning of **reduced ground clearance**, if the dynamic mode is activated and if the ignition is switched on ⇒ page 155, *Chassis controls*.
- If the warning/indicator light flashes in conjunction with the  warning/indicator light, you should not drive the vehicle immediately in order to prevent damage to the underbody. The two warning/indicator lights flashing together points to an extreme Low level. A very *pronounced lowering* of the vehicle (extreme Low level) can result, for example, from a heavy load. As soon as the level has returned to normal, the warning/indicator lights stop flashing, and you can drive away.

#### Note

If the warning/indicator light flashes in conjunction with the  warning/indicator light, you should not drive the vehicle

because low-lying vehicle parts can bottom out as you drive over uneven ground and be damaged as a result.

### Safety belts

*This warning/indicator light reminds you to put on your safety belt.*

The  warning/indicator light illuminates when the ignition is switched on to remind the driver and (on USA models only) any front passenger to put on the safety belt. Additionally, an acoustic warning (gong) will also sound.

For more information ⇒ *page 175, Safety belt warning light.*

### High beam

The  warning/indicator light illuminates when the high beams are on or when you use the headlight flasher. For more information about using the high beams, see ⇒ *page 60.*

### Tire pressure monitoring system - telltale indicator lamp

*The warning/indicator light appears in the event of a significant loss of tire pressure or if there is a malfunction.*

The indicator light  illuminates to check the function when you switch on the ignition.

If the  symbol remains on or blinks after you switch on the ignition, there is a loss of tire pressure or a system malfunction. If there is a system malfunction, see your authorized Audi dealer as soon as possible.

Detailed information on the tire pressure monitoring system can be found in ⇒ *page 298.*

### **CRUISE**/ Cruise control

The **CRUISE** (USA models) /  (Canada models) warning/indicator light illuminates when the cruise control is activated.

### **ABS**/ Anti-lock brake system (ABS)

*This warning/indicator light monitors the ABS and the electronic differential lock (EDL).*

The **ABS** (USA models) /  (Canada models) warning/indicator light will come on for a few seconds when the ignition is switched on. The light will go out after an automatic check sequence is completed.

#### **There is a malfunction in the ABS when:**

- The warning/indicator light does not illuminate when you switch on the ignition.
- The warning/indicator light does not go out after a few seconds.
- The warning/indicator light illuminates while driving.

**The brake system will still respond even without the assistance of the ABS system. See your authorized Audi dealer as soon as possible to restore full braking performance.** For more information regarding the ABS ⇒ *page 229.*

**The ABS warning light and the brake warning light come on together. The ABS will not work and you will notice a change in braking response and performance.**

#### **Malfunction in the brake system**

If the brake warning light ⇒ *page 19* and the ABS warning illuminate *together* there may be a malfunction in the ABS, and there may also be a malfunction in the brake system itself ⇒ .



In the event of a **malfunction in the brake system** the warning/indicator light **BRAKE** (USA models) /  (Canada models) in the instrument cluster flashes. By pressing the **CHECK** button, you can bring up a driver message which explains the malfunction in more detail. Please note ⇒ *page 32.*

#### **Malfunction in the electronic differential lock (EDL)**

The EDL works together with the ABS. The ABS warning light will come on if there is a malfunction in the EDL system ⇒ *page 227.* ►



See your authorized Audi dealer as soon as possible.

### WARNING

- If the **ABS** (USA models) /  (Canada models) warning light does not go out, or if it comes on while driving, the ABS system is not working properly. The vehicle can then be stopped only with the standard brakes (without ABS). You will not have the protection ABS provides. Contact your authorized Audi dealer as soon as possible.
- *USA models:* If the **BRAKE** warning light and the **ABS** warning light come on together, the rear wheels could lock up first under hard braking. Rear wheel lock-up can cause loss of vehicle control and an accident. Have your vehicle repaired immediately by your authorized Audi dealer or a qualified workshop. Drive slowly and avoid sudden, hard brake applications.
- *Canada models:* If the brake warning light  and the ABS warning light  come on together, the rear wheels could lock up first under hard braking. Rear wheel lock-up can cause loss of vehicle control and an accident. Have your vehicle repaired immediately by your authorized Audi dealer or a qualified workshop. Drive slowly and avoid sudden, hard brake applications.

### **Parking brake**

The indicator light monitors the parking brake.

When the parking brake is applied and the ignition is switched on, the  (USA models) /  (Canada models) indicator light comes on. The indicator light must go out when the parking brake is released.



### **BRAKE/** **Brake system**

The warning/indicator light flashes if brake fluid level is low, if there is an ABS system malfunction or a parking brake malfunction.

The **BRAKE** (USA models) /  (Canada models) light illuminates when the ignition is turned on. It goes out after the engine has been started. This indicates that the brake warning light is functioning properly.

**If the brake warning light does not light up when the engine is cranking, there may be a malfunction in the electrical system. In this case, contact your Audi dealer.**



If the brake system warning/indicator light flashes, there is a brake system malfunction. By pressing the **CHECK** button, you can bring up a driver message which explains the malfunction in more detail ⇒ *page 32*.

If the ABS fails, the ABS warning/indicator light **ABS** (USA models) /  (Canada models) flashes together with the brake system warning/indicator light ⇒ .

(USA models): If the warning light **BRAKE** and the warning light  illuminate together, immediately contact your authorized Audi dealer or qualified workshop to have all brake pads inspected ⇒ *page 36*.

When the light comes on, an audible warning signal is also given.

### WARNING

- *USA models:* If the **BRAKE** warning light and the **ABS** warning light come on together, the rear wheels could lock up first under hard braking. Rear wheel lock-up can cause loss of vehicle control and an accident. Have your vehicle repaired immediately by your authorized Audi dealer or a qualified workshop. Drive slowly and avoid sudden, hard brake applications.
- *Canada models:* If the brake warning light  and the ABS warning light  come on together, the rear wheels could

lock up first under hard braking. Rear wheel lock-up can cause loss of vehicle control and an accident. Have your vehicle repaired immediately by your authorized Audi dealer or a qualified workshop. Drive slowly and avoid sudden, hard brake applications.

- If the brake warning/indicator light does not go out after a few seconds and the parking brake is released, or lights up while you are driving, the fluid level in the brake fluid reservoir is too low. If you believe that it is safe to do so, proceed immediately at low speed to the nearest authorized Audi dealer or qualified repair facility and have the brake system inspected.
- Always keep in mind that after several brake applications, you will need greater pressure on the brake pedal to stop your vehicle. Do not rely on strained brakes to respond with maximum stopping power in critical situations. You must allow for increased braking distances. The extra distance used up by fading brakes could lead to an accident.

# Driver information display

## Introduction

### General notes

The driver information display inside the instrument cluster provides you, the driver, with much useful information.



Fig. 9 Instrument cluster: center display

Information from the Driver Information System is shown in the display in the center of the instrument cluster.

When you turn on the ignition and while you are driving, some functions and vehicle components are scanned for their operating status. Malfunctions or required service procedures are signalled audibly and shown by red and yellow lighted symbols and reminders to the driver in the display.

The driver is also shown information about radio and CD operation and directions for the navigation system. You can find additional information on these subjects in the MMI manual.

The Driver Information System provides the following functions:

|                          |           |
|--------------------------|-----------|
| Sound system display     | ⇒ page 21 |
| Outside air temperature  | ⇒ page 22 |
| Digital speedometer      | ⇒ page 22 |
| Door open indicator      | ⇒ page 22 |
| Defective light bulb     | ⇒ page 23 |
| Service interval display | ⇒ page 23 |
| Auto Check system        | ⇒ page 30 |
| Driver information       | ⇒ page 30 |

|                          |            |
|--------------------------|------------|
| Speed warning system     | ⇒ page 28  |
| Trip computer            | ⇒ page 24  |
| Cruise control           | ⇒ page 111 |
| Adaptive cruise control* | ⇒ page 113 |
| Selector lever position  | ⇒ page 138 |
| Adaptive Air Suspension* | ⇒ page 158 |
| Tire pressure monitoring | ⇒ page 298 |

### **i** Tips

In the event of a malfunction either a red or yellow icon appears in the display. Red symbols indicate **Danger** ⇒ page 31. Yellow symbols indicate a **Warning** ⇒ page 34.

### Sound system display



Fig. 10 Display: sound system

If priority 1 or priority 2 faults are not shown by the Auto Check Control, the name of the radio station you are tuned to or the frequency and the reception range are shown in the upper area of the display.

When the CD is in use, the title of the track being played is shown. The number of the CD (CD1 to CD6) currently being played is also shown.

### Outside temperature display



Fig. 11 Display: outside temperature

At temperatures below 41 °F (+5 °C) a snowflake symbol appears ahead of the temperature display. It is intended to remind the driver to pay special attention to **ice on the road**.

If the vehicle is stationary, or if you are driving at a very low speed, the temperature shown in the display might be slightly higher than the actual outside temperature. This is caused by the heat being radiated from the engine.

If you have selected the °C (degrees Celsius) unit for temperature in the MMI, the outside temperature display also appears automatically in °C.

#### WARNING

- Never rely exclusively on the outside temperature display to determine if a road surface is icy or not. Keep in mind that road surfaces, especially bridges and overpasses, could be ice covered and slippery even at an outside temperature above 41 °F (+5 °C).
- Always remember, even if the “snowflake” symbol (ice warning) does not appear in the display, black ice could be on the road.
- Always reduce your speed and drive with special care in cold weather conditions when the chance of encountering icy road surfaces increases.

### Digital speedometer



Fig. 12 Display: Digital speedometer

Current speed appears in the display. Speed is shown in 1 mph measures (USA models) or 1 km/h measures (Canada models).

You can switch the display from miles to kilometers and vice versa via the MMI.

### Open door or trunk lid warning

*The pictogram alerts you when doors or the rear lid have been left open.*



Fig. 13 Display: open door or rear lid warning

With the ignition switched on, the open door or rear lid warning illuminates when at least *one* door or the hood or the trunk lid is not closed. The symbol also shows you *which* door(s) or lid is not closed.

In the illustration ⇨ *fig. 13* it is the driver's door, the left rear door and the rear lid. As soon as all the doors, the hood, the rear lid and the fuel filler cap are properly closed, the door and rear lid warning turns off and the Driver Information System functions selected are displayed again.

### Defective light bulb warning

The defective light bulb warning tells you when a vehicle light bulb has become defective.



Fig. 14 Display: defective light bulb warning

The defective light bulb warning monitors the function of the light bulbs. If this symbol  illuminates, a brake light, a turn signal (front or rear), a headlight, the backup light, a fog light or a rear fog light has failed.

#### WARNING

- Light bulbs are pressurized and could explode while they are being changed causing serious personal injury.
- Work with due care when handling the high-voltage section of gas discharge (xenon) lights. Failure to do so could result in death or serious injury.

#### Tips

Have the bulb replaced or the connection repaired by your authorized Audi Service department.

### Service interval display

The service interval display reminds you when your next service is due.



Fig. 15 Display: Service interval display

The schedule for the next oil change or inspection is calculated automatically and displayed accordingly. The display works in two stages:

#### Service reminder

30 days before the next service is due, a service reminder appears in the display when you turn on the ignition ⇒ *fig. 15*.

After about 5 seconds the display switches back to normal. The distance and time remaining are updated each time the ignition is turned on until the date due for service is reached.

#### Service due

When the due date for service is reached, the message **Service due !** appears in the instrument cluster immediately after you turn on the ignition. Additionally, a warning tone sounds. After about 5 seconds the display switches back to normal.

#### Calling up the service schedules

If or when an oil change or inspection is due, can be shown in the MMI display by selecting the service interval display in the car menu. Select **CAR** function button > **Systems\*** control button > **Service interval display** or **CAR** function button > **Car systems\*** control button > **Servicing & checks** > **Service intervals**. ▶

## Resetting the service interval display

Your authorized Audi dealer will reset the corresponding service schedule after performing the appropriate service on your vehicle. You also have the possibility to reset the oil change schedule after having performed an oil change according to Audi specifications. Select **CAR** function button > **Systems\*** control button > **Service interval display** > **Reset oil change interval** or **CAR** function button > **Car systems\*** control button > **Servicing & checks** > **Service intervals** > **Reset oil change interval**.

### ! Note

If you disconnect the battery terminals, no calculations can be made for the service interval display during this time and no service reminder will appear. Remember that observing the proper service intervals is vitally important to extending the life of your vehicle, particularly the engine, and maintaining its value. Do not exceed the time interval for the next service, even if the vehicle mileage is low.

### i Tips

- Do not reset the display between oil changes, otherwise the display will be incorrect.
- The information in the Service Reminder remains stored even when the vehicle battery is disconnected.

## Trip computer

### Introduction

The trip computer gives you information on current and average fuel mileage, average speed, fuel range and driving time.



Fig. 16 Trip computer display: Average fuel mileage

The following driving information is continuously evaluated by the trip computer and can be displayed sequentially in the instrument cluster display.

### Fuel range

The estimated cruising range in miles (km) appears in the display. This tells you how far your vehicle will be able to travel on the current tank of fuel and with the same driving style. The display changes in increments of 6 miles (10 km).

The cruising range is calculated based on the fuel consumption for the last 18 miles (30 km). If you drive conservatively, the cruising range will increase.

### Average fuel mileage

The average fuel economy in MPG (l/100 km) since you last cleared the memory appears in this display. You can use this display to adjust your driving technique to achieve a desired mileage.

### Current fuel mileage

The instantaneous fuel consumption in miles per gallon (l/100 km) is shown in this display. You can use this display to adjust your driving technique to achieve a desired mileage. ►

Fuel consumption is recalculated at intervals of 33 yards (30 meters). When the vehicle is stationary, the most recent fuel consumption is displayed.

### Average speed

The average speed in mph (km/h) since the last time the display was reset appears in the display.

### Elapsed time

The length of time that you have been driving since you last reset the memory appears in this display.

### Distance

The distance that has been covered since the last time the memory was cleared appears in the display.

#### Tips

- Fuel consumptions (average and current), range and speed are displayed in metric units on Canadian models.
- All stored values will be lost if the vehicle battery is disconnected.

## Memories

The trip computer is equipped with two fully automatic memories as well as an efficiency program\*.



Fig. 17 Trip computer display: memory level 1

You can switch between the trip computer 1 and 2 and the efficiency program\* by pressing the **RESET** button **(B)** ⇒ page 25, fig. 18.

You can tell which memory level is currently active by the number or the sign in the display

⇒ fig. 17. The data from the single-trip memory (memory level 1) is being displayed if a **1** appears in the display. If a **2** is shown, then the data from the total-trip memory is being displayed (memory level 2). The fuel pump nozzle  indicates the efficiency program\* ⇒ page 26.

### Single-trip memory (Trip computer 1)

The single-trip memory stores the trip information from the time the ignition is turned on until it is turned off. If the trip is continued **within 2 hours** from the time the ignition was turned off, the new data will be included in the calculation of the current trip information. If the trip is interrupted for **more than 2 hours** the memory is reset automatically.

### Total-trip memory (Trip computer 2)

Unlike the single-trip memory, the total-trip memory is not reset automatically. This permits you to evaluate your driving data for the entire period between manual resets.

### Efficiency program\*

The efficiency program can help you to use less fuel ⇒ page 26.

## Operation

The trip computer is controlled by two switches on the windshield wiper lever.

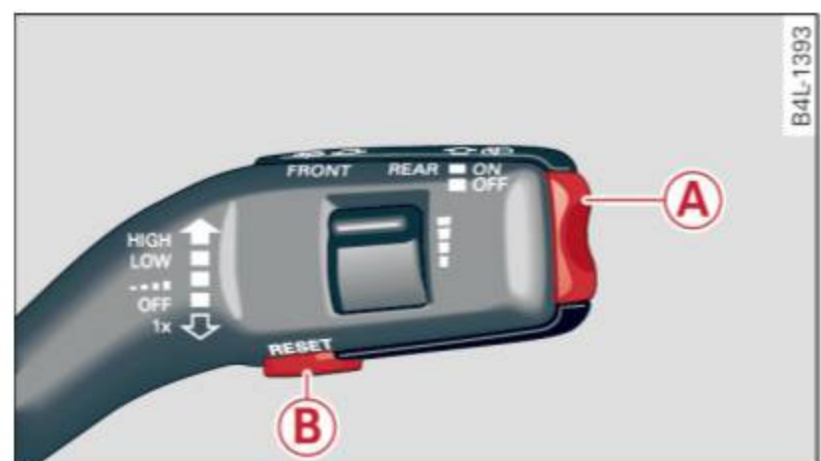

Fig. 18 Windshield wiper lever: controls for the trip computer

- ▶ To display the trip computer memory levels, press the **RESET** button **(B)** ⇒ fig. 18 repeatedly until the desired memory level is shown in the display. ▶

- ▶ To display trip information within a memory level, press the top or bottom part of the function selection switch **(A)**.

The trip computer will not operate unless the ignition is on. When you turn on the ignition, the function that was in use when you last turned the ignition off will be displayed.

In addition to information on the trip computer (trip computer 1, 2 and efficiency program\*), the digital speedometer and information regarding the navigation system\* can also be displayed. To switch the display between the different information, tap the **[RESET]** button **(B)** briefly.

### Setting values to zero

To erase the single or total trip computer values, select the desired function and press and hold the **[RESET]** button **(B)** for at least one second. You can also erase\* the values with the MMI ⇒ *page 26*.

**All** values currently displayed in the efficiency program\* are also erased with the single trip computer.

#### **i** Tips

All stored values will be lost if the vehicle battery is disconnected.

### MMI settings

*Basic settings for the trip computer can be made in the MMI.*

- ▶ Select: **[CAR]** function button > **Systems\*** control button > **Instrument cluster** > **On-board computer 1** or **On-board computer 2**.

The values in the single-trip or the total-trip memory can all be reset to zero at the same time under **Reset** in the menu.

In addition, you can determine what information from the trip computer should be shown in the instrument cluster display. If one of the pieces of driver information is turned **Off**, that driver information will not be shown in the display. The information will continue to be

calculated by the trip computer and can be turned back **On** at any time.

#### **i** Tips

- This function is not available on all vehicles.
- The driving information in the efficiency program\* is also reset to zero with the single-trip memory.

## Efficiency program

### Description

Applies to vehicles: with efficiency program



Fig. 19 Display: efficiency program

- ▶ Press the **[RESET]** button **(B)** ⇒ *page 25*, *fig. 18* repeatedly until the efficiency program appears in the display.

The efficiency program can help you to use less fuel. It evaluates driving information in reference to fuel consumption and shows other equipment influencing consumption. Fuel economy messages ⇒ *page 27* provide tips for efficient driving.

The efficiency program uses distance and consumption data from trip computer 1. If the data are deleted in the efficiency program, those values are also reset in trip computer 1.

## Other equipment

Applies to vehicles: with efficiency program

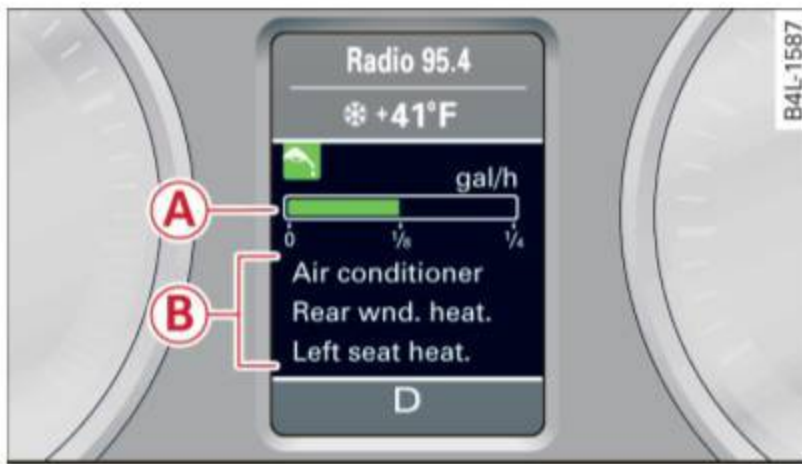

Fig. 20 Display: other equipment

- ▶ In the efficiency program, press the function selection switch ⇒ page 25, fig. 18 (A) repeatedly until the other equipment appears in the display.

Other equipment that is currently affecting fuel consumption is listed in the efficiency program. The display shows up to three other items of equipment (B). The equipment using the most fuel is listed first. If more than three items using fuel are switched on, the equipment that is currently using the most fuel is displayed.

A scale (A) also shows the current total consumption of all other equipment.

## Fuel economy messages

Applies to vehicles: with efficiency program



Fig. 21 Display: fuel economy message

Fuel economy messages are displayed when fuel consumption is increased by certain conditions. If you follow these fuel economy messages, you can reduce your vehicle's consumption of fuel. The messages appear automatically and are only displayed in the efficiency

program. The fuel economy messages turn off automatically after a certain period of time.

- ▶ To turn a fuel economy message off immediately after it appears, press the **RESET** button ⇒ page 25, fig. 18 (B), or
- ▶ Press the function selection switch ⇒ page 25, fig. 18 (A).

### **i** Tips

- Once you have turned a fuel economy message off, it will only appear again after you turn the ignition on again.
- The fuel economy messages are not displayed in every instance, but rather in intervals over a period of time.

## On-Board Diagnostic system (OBD)

### Malfunction Indicator Lamp (MIL)

The Malfunction Indicator Lamp (MIL)  in the instrument cluster ⇒ page 14, fig. 8 is part of the On-Board Diagnostic (OBD II) system.

The warning/indicator light illuminates when the ignition is switched on and goes out after the engine starts and the idle has stabilized. This indicates that the MIL is working properly.

**If the light does not go out** after the engine is started, or illuminates while you are driving, a malfunction may exist in the engine system. If the light illuminates, the catalytic converter could be damaged.

Continue driving **with reduced power** (avoiding sustained high speeds and/or rapid accelerations) and have the condition corrected. Contact your authorized Audi dealer.

If the light illuminates, the electronic speed limiter may also be malfunctioning. For more information ⇒ page 28, *Electronic speed limiter*.

**An improperly closed fuel filler cap may also cause the MIL light to illuminate (only vehicles with gasoline engine)** ⇒ page 259.

## On-Board Diagnostics



Fig. 22 Location of Data Link Connector (DLC)

On-Board Diagnostics monitors the components of your emission control system. Each monitored component in your engine system has been assigned a code. In case of a malfunction, the component will be identified and the fault stored as a code in the control module memory.

The MIL light may also illuminate if there is a leak in the on-board fuel vapor recovery system. If the light illuminates after a refuelling, stop the vehicle and make sure the fuel filler cap is properly closed (only vehicles with gasoline engine) ⇒ *page 259*.

In order to make an accurate diagnosis, the stored data can only be displayed using special diagnostic equipment (generic scan tool for OBD).

In order to connect the special diagnostic equipment, push the plug into the Data Link Connector (DLC). The DLC is located to the right of the hood release ⇒ *fig. 22*.

Your authorized Audi dealer or qualified workshop can interpret the code and perform the necessary repair.

### WARNING

Do not use the diagnostic connector for personal use. Incorrect usage can cause malfunctions, which can increase the risk of a collision!

## Electronic speed limiter

Your vehicle may be factory equipped with tires that are rated for a maximum speed of 130 mph (210 km/h). This is less than the maximum speed of your vehicle. To reduce the risk of sudden tire failure and loss of control if the vehicle is operated at excessive speeds, your vehicle also has an electronic speed limiter. The electronic speed limiter prevents your vehicle from going faster than the tire speed rating. For more information ⇒ *page 291*.

If the engine control unit receives faulty vehicle roadspeed signals, the Malfunction Indicator Lamp (MIL)  will illuminate. If this occurs, contact the nearest authorized Audi dealer for assistance.

### WARNING

Always observe the posted speed limits and adjust your speed to suit prevailing road, traffic and weather conditions. Never drive your vehicle faster than the maximum speed rating of the tires installed.

## Speed warning system

### Overview

*The speed warning system helps you to keep your driving speed below a set speed limit.*



The speed warning system warns the driver if he exceeds a previously stored maximum speed. A warning tone will sound as soon as the vehicle speed exceeds the set speed by about 3 mph (3 km/h). At the same time, a warning symbol appears in the display.

The speed warning system has **two warning thresholds** that function independently of each other and that have somewhat different purposes:

### Speed warning 1

You can use speed warning 1 to set the maximum speed while you are driving. This setting ►

will remain in effect until you turn off the ignition, assuming that you have not changed or reset the setting.



The speed warning symbol  (USA models)/  (Canada models) in the warning 1 display appears when you exceed the maximum speed. It goes out when the speed falls below the stored maximum speed.

The speed warning symbol will also go out if the speed *exceeds* the stored maximum speed by more than about 25 mph (40 km/h) for at least 10 seconds. The stored maximum speed is deleted.

Setting speed warning 1 ⇒ *page 29*.

## Speed warning 2

Storing warning 2 is recommended if you *always* want to be reminded of a certain speed, for example when you are traveling in a country that has a general maximum speed limit, or if you do not want to exceed a specified speed for winter tires.

The speed warning 2 symbol,  (USA models)/  (Canada models) appears in the display when you exceed the stored speed limit. Unlike warning 1, it will not go out until the vehicle speed drops below the stored speed limit.

Setting speed warning 2 ⇒ *page 29*.

### Tips

Even though your vehicle is equipped with a speed warning system, you should still watch the speedometer to make sure you are not driving faster than the speed limit.

## Speed warning 1: setting a speed limit

Warning threshold 1 is set by the **CHECK** button.





Fig. 23 CHECK button in the instrument cluster

## Storing the maximum speed

- ▶ Drive at the desired maximum speed.
- ▶ Briefly press the **CHECK** button ⇒ *fig. 23*.

## Resetting the maximum speed

- ▶ Drive the vehicle at a speed of at least 3 mph (5 km/h)
- ▶ Press the **CHECK** button for more than 2 seconds.

The speed warning symbol  (USA models)/  (Canada models) will appear briefly in the display when you release the **CHECK** button to indicate that the maximum speed has been stored successfully.

The maximum speed remains stored until it is changed by pressing the **CHECK** button again briefly or until it is deleted by a lengthy push on the button.

## Speed warning 2: setting a speed limit

Warning threshold 2 is set, changed and deleted in the MMI.

- ▶ Select: **CAR** function button > **Systems\*** control button > **Instrument cluster** > **Speed warning**. Or
- ▶ Select: **CAR** function button > **Car systems\*** control button > **Driver assist** > **Speed warning**.

Warning threshold 2 can be set in the speed range starting from 20 mph to 150 mph ▶

(30 km/h to 240 km/h). Settings can each be adjusted in intervals of 5 mph (10 km/h).

## Auto Check Control

### Introduction

The Auto-Check control monitors the function of certain vehicle features and components. It simply makes sure these features and components are working properly. The Auto-Check control works as long as the ignition is on, as well as whenever the vehicle is driven.

If a component is malfunctioning or if the need for an urgent repair has been detected, this will appear in the instrument cluster display. You will also hear an audible warning tone. The displays are color coded in either red or yellow depending on their level of priority.

A red symbol means **Danger**, a yellow symbol indicates **Warning**. In certain situations, information message for the driver appear in addition to the red and yellow symbols.

### Function test: automatic transmission

The Auto-Check Control will automatically perform a test each time you switch on the ignition. With the selector lever in **P** or **N**, the following message appears in the display:

#### When stationary apply foot brake while selecting gear.

When you select a different gear (for example: **R**, **D**, etc.), the message will disappear and the Auto-Check function is displayed.

If there is a malfunction, then the malfunction message will appear about 15 seconds after the you start the vehicle. At the same time you will hear a warning tone.

### Driver information messages

Driver information messages are shown in the instrument cluster display in addition to the red and yellow symbols.



Fig. 24 Instrument cluster: CHECK button

For example, if the transmission selector lever is not in the **P** position when the engine is turned off, the following message appears:

#### Shift to **P** otherwise vehicle can roll away. Doors do not lock if you are not in **P**.

The ignition key can only be removed with the selector in this position. This and other messages are brought up if a function cannot be carried out.

### Driver messages and red symbols

If a red symbol appears in the display, a driver message can be shown by pressing the **CHECK** button.

For example, the symbol for a problem with engine oil pressure  appears in the display. If you then press the **CHECK** button, the following driver message appears in the display:

#### Switch off engine ! Oil pressure too low

The driver message in the display goes out after about 5 seconds. The driver message can be displayed again by briefly pressing the **CHECK** button.

### Driver messages and yellow symbols

If a yellow symbol appears in the display, a driver message is also displayed automatically. ►

For example, the symbol  appears in the display, indicating low windshield washer fluid level. The following message also appears:

### Please refill washer fluid

The driver message disappears after a few seconds. The driver message can be displayed again by briefly pressing the **CHECK** button.

## Red symbols

A red symbol means DANGER.



Fig. 25 Display: engine coolant level warning (priority 1)

- ▶ Pull off the road.
- ▶ Stop the vehicle.
- ▶ Turn off the engine.
- ▶ Check the malfunctioning system. Contact your authorized Audi dealer or a qualified workshop for assistance.









Red symbols indicate a priority 1 malfunction - Danger!

With a priority 1 malfunction, a large symbol appears in the center area of the display ⇒ *fig. 25*. When the symbol appears, *three* warning tones sound in succession. The symbol continues to blink until the malfunction has been repaired.





If there are *more than one* priority 1 malfunctions, the symbols appear one after the other for about 2 seconds.

An additional driver message can also be displayed by briefly pressing the **CHECK** button.

The red symbols mean:

|   |  |
|---|--|
|    | Alternator malfunction<br>⇒ <i>page 31</i>   |
|    | <b>USA models:</b> Brake system malfunction<br>⇒ <i>page 32</i>                      |
|    | <b>Canada models:</b> Brake system malfunction<br>⇒ <i>page 32</i>                   |
|    | Engine coolant level too low/engine coolant temperature too high<br>⇒ <i>page 32</i> |
|    | Engine oil pressure too low<br>⇒ <i>page 33</i>                                      |
|  | Refill AdBlue*<br>⇒ <i>page 261</i>  |
|  | AdBlue malfunction*<br>⇒ <i>page 261</i>   |
|  | Faulty steering<br>⇒ <i>page 33</i>  |
|  | Faulty ignition switch<br>⇒ <i>page 34</i>   |

### Tips

- If the warning/indicator light **BRAKE** (USA models)/ (Canada models) in the instrument cluster flashes, there is a brake system malfunction. By pressing the **CHECK** button, you can bring up a driver message which explains the malfunction in more detail. Please note ⇒ *page 32*.
- Speed warnings threshold 1  (USA models)/ (Canada models) and threshold 2  (USA models)/ (Canada models) are also shown as red symbols. The warning is always shown as a small symbol in the upper area of the display ⇒ *page 28*.

## Alternator malfunction

If the  symbol in the instrument panel display flashes, then there is a malfunction in the alternator or the vehicle electronics. A warning to the driver will appear, too. The driver

warning goes out after about 5 seconds, but it can be brought up at any time by pressing the **CHECK** button again.

Usually, you can still drive to the next dealership. Turn off all but the most necessary electrical consumers, since these drain the vehicle's battery.

### Note

If the  warning symbol (coolant system malfunction) also lights up on the instrument panel during the trip ⇒ *page 32*, then you have to stop immediately and turn off the engine. The coolant pump is not working anymore - danger of damage to the engine!

### **BRAKE/** Brake system malfunction

*A malfunction in the brake system must be repaired as soon as possible.*

If the **warning/indicator light BRAKE** (USA models)/ (Canada models) in the instrument cluster flashes, there is a brake system malfunction. By pressing the **CHECK** button, you can bring up a driver message which explains the malfunction in more detail.

#### Stop vehicle and check brake fluid level



- ▶ Pull off the road.
- ▶ Stop the vehicle.
- ▶ Turn off the engine.
- ▶ Check the brake fluid level ⇒ *page 274*.
- ▶ Contact your nearest authorized Audi dealer or qualified workshop if necessary.

#### Warning! Fault in brake system. Contact workshop

- ▶ Drive carefully to the nearest authorized Audi dealer or qualified workshop and have the malfunction corrected ⇒ .

If the ABS system malfunctions, the ABS warning/indicator light illuminates together with the brake system malfunction warning/indicator light ⇒ .

### WARNING

- Always observe the warnings in ⇒ *page 255, Engine compartment*, before opening the hood and checking the brake fluid.
- Driving with low brake fluid is a safety hazard. Stop the car and get professional assistance.
- *USA models:* If the **BRAKE** warning light and the **ABS** warning light come on together, the rear wheels could lock up first under hard braking. Rear wheel lock-up can cause loss of vehicle control and an accident. Have your vehicle repaired immediately by your authorized Audi dealer or a qualified workshop. Drive slowly and avoid sudden, hard brake applications.
- *Canada models:* If the brake warning light  and the ABS warning light  come on together, the rear wheels could lock up first under hard braking. Rear wheel lock-up can cause loss of vehicle control and an accident. Have your vehicle repaired immediately by your authorized Audi dealer or a qualified workshop. Drive slowly and avoid sudden, hard brake applications.

### Engine cooling system malfunction

*A malfunction in the engine cooling system must be repaired as soon as possible.*

When the  symbol in the display blinks, then either the engine coolant *temperature* is too high, or the coolant *level* is too low. An additional driver message can also be displayed by pressing the **CHECK** button:

#### Switch off engine and check coolant level

- ▶ Pull off the road.
- ▶ Stop the vehicle.
- ▶ Turn off the engine.
- ▶ Check coolant level ⇒ *page 272*.
- ▶ Add coolant if necessary ⇒ *page 273*.
- ▶ Continue driving only after the engine coolant warning/indicator light goes out. ▶

- ▶ Contact your authorized Audi dealer for assistance if necessary.

If the engine coolant level is correct, then the radiator fan may be the cause of the malfunction.

If the  warning symbol (alternator malfunction) also lights up on the instrument panel ⇒ *page 31*, then the fan belt may be damaged.

### WARNING

- If your vehicle should break down for mechanical or other reasons, park at a safe distance from moving traffic, turn off the engine and turn on the hazard warning lights ⇒ *page 60, Emergency flasher*.
- Never open the hood if you see or hear steam or coolant escaping from the engine compartment - you risk being scalded. Wait until you can no longer see or hear steam or coolant escaping.
- The engine compartment of any vehicle is a dangerous area. Before you perform any work in the engine compartment, turn off the engine and allow it to cool. Follow the warning stickers ⇒ *page 255, Engine compartment*.

### Note

Do not continue driving if the  symbol illuminates. There is a malfunction in the engine cooling system – you could damage your engine.

## Engine oil pressure malfunction

The red engine oil pressure warning symbol requires immediate service or repair. Driving with a low-oil-pressure indication is likely to inflict severe damage to the engine.

If the  symbol appears in the display and blinks, the oil pressure is too low. An additional driver message can also be displayed by pressing the **CHECK** button:

**Switch off engine ! Oil pressure too low**

### Immediate actions

- ▶ Pull off the road.
- ▶ Stop the vehicle.
- ▶ Turn off the engine.
- ▶ **Check the engine oil level with the dipstick** ⇒ *page 269*.





### Dipstick readings checks too low

- ▶ Top off oil to the proper level ⇒ *page 270*.
- ▶ Make sure that the oil pressure warning symbol  appears no longer in the display before you start driving again.

### Dipstick reading checks OK

- ▶ If the oil pressure warning symbol  starts flashing again even though the engine oil level checks OK on the dipstick, **do not continue driving and do not let the engine run in idle**. Instead, contact your authorized Audi dealer for assistance.

### Tips

- The engine oil pressure symbol  is not an indicator for a low engine oil level. Do not rely on it. Instead, check the oil level in your engine at regular intervals, preferably each time you refuel, and always before going on a long trip.
- The yellow oil level warning indication  requires oil refill or workshop service without delay. Do not wait until the red oil pressure warning  starts to flash before you respond to the low oil level warning . By then, your engine may already have suffered serious damage.

## Steering malfunction

If there is a malfunction in the electronic steering column lock, the steering cannot be unlocked.

If the  symbol in the display blinks, there is a malfunction in the electronic steering column lock. An additional driver message can also be displayed by pressing the **CHECK** button:

**Do not drive vehicle: steering defective**

- ▶ Contact your nearest authorized Audi dealer or qualified workshop.
- ▶ Do **not** tow your vehicle.

 **WARNING**

Your vehicle must not be towed in the event of a malfunction in the electronic steering column lock because it cannot be steered due to the locked steering. If it is towed with the steering locked, there is the risk of an accident.

 **Ignition lock malfunction**

A malfunction in the ignition lock must be repaired immediately.

If the  symbol in the display blinks, there is a malfunction in the electronic ignition lock. An additional driver message can also be displayed by pressing the **CHECK** button:

**Ignition lock defective. Contact workshop !**

- ▶ Do **not** turn the engine off.
- ▶ Drive immediately to an authorized Audi dealer to have the malfunction corrected.

If there is a malfunction in the electronic ignition lock, the ignition cannot be turned off. Drive immediately to an authorized Audi dealer to have the cause of the malfunction corrected.

On vehicles with Convenience key\*, the engine should not be switched off using the **STOP** button because the engine cannot be started again after the ignition is switched off.

**Yellow symbols**

A yellow symbol means **WARNING**.

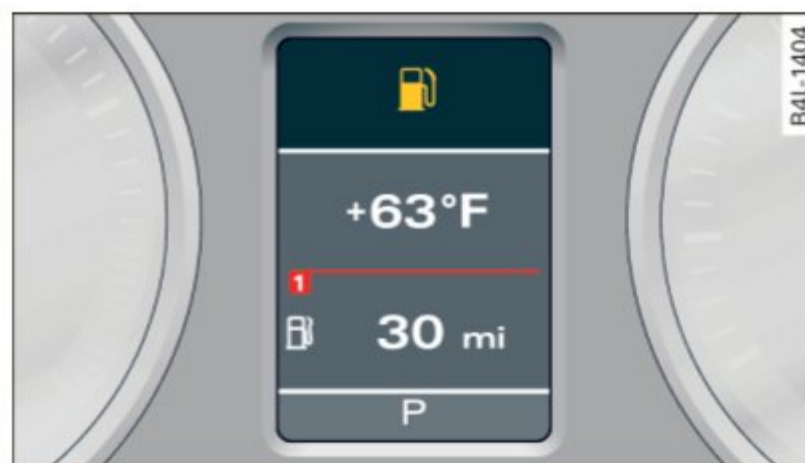





Fig. 26 Display: low fuel level warning (priority 2)



Yellow symbols indicate a priority 2 malfunction - Warning!



When a yellow warning symbol appears, one warning tone sounds. A driver message appears as well to explain the malfunction in more detail. The driver warning goes out after about 5 seconds, but it can be brought up again at any time by pressing the **CHECK** button.

Check the displayed function as soon as possible. If *more than one* priority 2 malfunction is detected, all symbols will appear one after the other for about 2 seconds.

Yellow symbols mean:

|   |  |
|---|--|
|  | Convenience key*<br>Key not in vehicle<br>⇒ page 108     |
|  | <b>USA models:</b> Defective brake light<br>⇒ page 23    |
|  | <b>Canada models:</b> Defective brake light<br>⇒ page 23 |
|  | Defective light bulb<br>⇒ page 23                        |
|  | Light/rain sensor defective<br>⇒ page 35                 |
|  | Windshield washer fluid level low<br>⇒ page 35           |

|   |   |
|---|---|
|                | Low fuel level<br>⇒ page 35   |
| <b>AdBlue</b>  | Refill AdBlue*<br>⇒ page 261  |
| <b>AdBlue</b>  | AdBlue malfunction*<br>⇒ page 261                                     |
|                | Battery voltage<br>⇒ page 36  |
|                | Worn brake pads<br>⇒ page 36  |
|                | Dynamic headlight range control defective<br>⇒ page 36                |
|              | Check engine oil level<br>⇒ page 36                                   |
|              | Engine oil sensor malfunction<br>⇒ page 36                            |
|              | Engine speed limitation*<br>⇒ page 36                                 |
|              | Diesel particulate filter* clogged<br>⇒ page 37                       |
|              | Adaptive light* defective<br>⇒ page 37                                |
|              | Ignition lock malfunction<br>⇒ page 37                                |
|              | Windshield wiper defective<br>⇒ page 37                               |
|              | Tire pressure monitoring system<br>Loss of air pressure<br>⇒ page 299 |
| <b>TPMS</b>   | Tire pressure monitoring system<br>System not available<br>⇒ page 299 |

|   |  |
|---|--|
|  | Battery in remote control key<br>⇒ page 39       |
|  | Automatic transmission malfunction<br>⇒ page 141 |

### Key not in vehicle

Applies to vehicles: with Convenience key

### Key not in vehicle

This reminder appears along with the  symbol if the master key is removed from the vehicle with the engine running. It is intended to remind you (e.g. when changing drivers) not to continue the journey without the master key.

If the master key is no longer in the vehicle, you cannot switch off the ignition after stopping the engine and you also cannot start the engine again. What is more, you cannot lock the vehicle from the outside.

### Light/rain sensor defective

#### Automatic headlights / automatic wipers defective

If the symbol illuminates, the light sensor has failed. For safety reasons the low beams are turned on permanently with the switch in **AUTO**. However, you can continue to turn the lights on and off using the light switch. In the case of a defect in the rain sensor, the windshield wiper lever functions are still available. Have the light/rain sensor checked as soon as possible by an authorized Audi dealer.

### Windshield washer fluid level too low

#### Please refill washer fluid

If the symbol illuminates, add windshield washer fluid to the washer system and also to the headlight washer system ⇒ page 279.

### Fuel supply too low

#### Please refuel

When this symbol  illuminates for the first time, the fuel reserve in your vehicle is still between 2.6 and 3.2 gallons (10-12 liters). Refuel as soon as possible ⇒ *page 258*.

If the symbol lights up, even when there is ample fuel in the tank, and the text **Tank system malfunction ! Contact workshop** appears in the display, there is a fault in the system. Contact a qualified workshop to have the fault rectified.

### **Battery voltage**

If the battery's state of charge is not in the optimal range, the  symbol is shown in the display and the driver message **Low battery charge: battery will be charged while driving** appears.

While this driver notification is displayed, you have to be prepared for limited starting capability.

### **Driver message appears and goes out again**

If this driver message appears after the ignition is turned on or while driving and it goes out again after a while, the battery has been adequately recharged.

### **Driver message appears and does not go out again**

If this driver notification appears after the ignition is turned on or while driving and does not go out again, the battery's state of charge is not in the optimal range. Starting capability is restricted. Have the battery checked by an authorized Audi dealer as soon as possible.

### **Worn brake pads**

#### **Brake pads !**

If the warning light illuminates, immediately contact your authorized Audi dealer or qualified workshop to have all brake pads inspected. On USA models the warning light 

comes on together with the warning light **BRAKE**. Both sets of brake pads on an axle must always be replaced at the same time.

### **WARNING**

Driving with bad brakes can cause a collision and serious personal injury.

– If the warning light  and the warning light **BRAKE**<sup>1)</sup> with the message **Brake pads!** comes on in the instrument cluster display, immediately contact your authorized Audi dealer or qualified workshop to have all brake pads checked or replaced if necessary.

### **Headlight range control**

#### **Headlight range control defective !**

If the symbol illuminates, the dynamic headlight range control is no longer working properly. Have the system checked and repaired at your authorized Audi dealer.

### **Engine oil level**

#### **Please check oil level**

When the symbol illuminates, check the engine oil level as soon as possible ⇒ *page 269*. Top off the oil at your earliest opportunity ⇒ *page 270*.

### **Engine oil sensor defective**

#### **Oil level ! Sensor defective**

If the symbol illuminates, contact your authorized Audi dealer and have the oil sensor inspected. Until you have this done, check the oil level each time you refuel just to be on the safe side ⇒ *page 269*.

### **Engine speed limitation**

Applies to vehicles: with engine speed limitation

 **Do not exceed max. engine speed of XXXX rpm**

1) **BRAKE**: USA models only

The  symbol illuminates when there is an engine control malfunction. The indicator light **EPC** in the instrument cluster also illuminates. The engine speed is limited to the speed displayed in the driver information system. Keep in mind that the engine speed will not exceed the value displayed in the driver information system, for example when downshifting.

Please go to an authorized Audi dealer or other qualified workshop to have the malfunction repaired.

### Diesel particulate filter clogged

Applies to vehicles: with diesel engine and diesel particulate filter

### Particulate filter See owner's manual

When the  symbol illuminates, you can alter your driving style to assist the filter self-cleaning process. Drive for approximately 15 minutes with the selector lever in the S position at a minimum speed of 37 mph (60 km/h) and an engine speed of approximately 2,000 RPM. The temperature increase that will result from this can burn off the soot in the filter. The symbol will switch off when the cleaning is successful. After a successful cleaning, there is no need to bring the car to an authorized dealer or qualified workshop because this is part of normal vehicle operation.

If the symbol  does not switch off, see your authorized dealer or other qualified workshop to have the problem corrected.

For more information on the diesel particulate filter, refer to  page 235.

### **WARNING**

Always adapt your speed to the current weather, road and traffic conditions. You should never disobey traffic laws in order to follow driving recommendations.

### Adaptive light defective

Applies to vehicles: with adaptive light

### adaptive light defective

When this symbol  illuminates, it means that adaptive light is defective. Go to an authorized dealership to have the headlights or the control unit for the adaptive light repaired.

### Ignition lock malfunction

If the  symbol in the display comes on, there is a malfunction in the electronic ignition lock. An additional driver message can be displayed by pressing the **CHECK** button:

### Ignition lock defective

- ▶ Drive to an authorized Audi dealer or qualified workshop at your earliest convenience to have the malfunction corrected.

### Windshield wipers faulty

### Windshield wiper defective

When this symbol  illuminates, it means that the electronics for the windshield wipers are defective. Please go to an authorized Audi dealer or qualified workshop to have the windshield wiper system repaired.

## Opening and closing

### Keys

#### Key set



Fig. 27 Key set

#### (A) Master key with remote control

You can centrally lock and unlock your vehicle and start the engine with the master key with remote control.

#### (B) Valet key

The valet key only fits the lock in the driver's door and the ignition lock. If you have to leave the key with somebody else, you are well-advised to turn over the valet key only  
⇒ page 41.

#### (C) Emergency key

The emergency key is only for temporary use if the vehicle key should be lost or misplaced  
⇒ ⚠.

#### Key replacement

If you lose a key, contact your authorized Audi dealer immediately to have the *lost* key disabled. Be sure to bring all your keys with you.

#### Registered keys

You can check to find out how many keys have been registered to your vehicle. Therefore, when buying a used vehicle, make sure to get all of the remote keys belong to it.

Calling up the registered keys ⇒ page 12.

#### Data in the master key

While you are driving, service and maintenance relevant data are being continuously

stored on your master key. Your Audi Service Advisor can read out these data and tell you about work that is needed on your vehicle. This also applies to vehicles with Convenience key\*.

#### ⚠ WARNING

- Do not leave your vehicle unattended with the key in the ignition lock. Entry by unauthorized persons could endanger you or result in theft or damage the vehicle. Always lock all doors and take the key.
- Do not leave children unattended in the vehicle, especially with access to vehicle keys. Unguarded access to the keys provides children the opportunity to start the engine and/or activate vehicle systems such as the power windows etc. Unsupervised operation of any vehicle system by children can result in serious injury.

#### i Tips

- If you open the driver's door with the key left in the ignition lock, a chime will sound. This is your reminder to remove the key and lock the door.
- For security reasons, replacement keys are only available from Audi dealers.

#### Master key with remote control

The remote control allows you to lock or unlock the vehicle electronically.



Fig. 28 Fold-up master key with remote control

- ▶ To fold the key out and back in place, press the release button ⇒ fig. 28.

The transmitter and battery are located in the head of the remote control. The receiver is located inside the vehicle. The maximum effective range depends on several things. Remember, if the battery is weak, the effective range decreases.

If you need to replace the remote control, or if you need to have it repaired, you must see your authorized Audi dealer. Only then can you use the key again.

### Personalizing the master key

When the ignition is turned off or when the vehicle is locked, various convenience settings are stored automatically and assigned to the key that was used. The settings that are assigned to the master key are recalled automatically when the vehicle is unlocked, when the door is opened or when the ignition is switched on.

Settings are saved for the following systems:

- Climate control
- Central locking
- Windows
- Ambience lighting\*
- Seat memory\*
- Steering wheel heating\*
- Adaptive cruise control\*
- Audi side assist\*
- Parking system\*

The **Remote control key** function must be activated in the MMI ⇒ *page 74*, so that the settings for the driver's seat (including the settings for the steering column and exterior mirrors) are saved on the master key through the seat memory when the vehicle is locked, and are set automatically when the vehicle is unlocked.

#### Tips

- If the ignition is switched on, the remote control system is deactivated.
- The remote control system can be affected by other systems operating in the same frequency range close to the vehi-

cle, such as mobile telephones, television broadcasting stations, etc.

- For Declaration of Compliance to United States FCC and Industry Canada regulations ⇒ *page 328*.

### Check light in the master key

*The check light in the master key provides information about different conditions.*



**Fig. 29** Check light in the master key

Check light functions in the master key:

#### Vehicle within range of the key

If the vehicle is within range of the key, the check light comes on briefly once when a button is pressed.

#### Vehicle outside the range of the key

If the vehicle is outside the range of the key, the check light comes on briefly once and then shows the status of the vehicle door locks:

- If the light is flashing quickly, the vehicle is not locked.
- If the light is flashing slowly, the vehicle is locked.

#### State of master key battery

If the check light does not come on, the battery is dead and has to be replaced. In addition, when the battery is dead the  symbol appears in the instrument cluster display as well as the message:

#### Please change key battery

Battery replacement ⇒ *page 40*.

**i Tips**

Please note that the current state of the vehicle door locks can only be recalled with the master key that was last used to lock the vehicle. It is possible that a different state is shown for the door locks on the other master key which is not the same as that of the vehicle.

**Master key battery replacement**

Each master key contains a battery housed under the cover.



Fig. 30 Master key: opening the cover

- ▶ Pry apart the base ⇒ *fig. 30* **A** and the cover **B** **carefully** with a coin.
- ▶ Remove the cover (arrow).
- ▶ Remove the dead battery from the cover.
- ▶ Install the new battery. Please make certain that the “+” sign on the battery faces down in the cover. Correct polarity is shown on the cover.
- ▶ Place the cover with the new battery on the key base and press both parts together.

**For the sake of the environment**

Dispose of dead batteries properly so as not to pollute the environment.

**i Tips**

The replacement battery must be the same specification as the original.

**Electronic immobilizer**

*The immobilizer helps to prevent unauthorized use of your vehicle.*

A computer chip inside your key automatically deactivates the electronic immobilizer when you insert the key in the ignition lock, or on vehicles with Convenience key\*, when the key is inside the vehicle. When you remove the key from the ignition lock, or on vehicles with Convenience key, when you remove the key from the vehicle, the electronic immobilizer is automatically activated once again.

**! WARNING**

Always take the key with you when you leave the vehicle. The key can disarm the electronic engine immobilizer and permit an unauthorized person to start the engine and enable operation of the vehicle systems such as power window or Panoramic sliding sunroof\* leading to serious personal injury.

**i Tips**

- The vehicle cannot be started if an unauthorized key is used. The vehicle may not start if another radio device such as a key for another vehicle or a transponder is located on the key ring.
- For Declaration of Compliance to United States FCC and Industry Canada regulations ⇒ *page 328*.

## Valet key function

The valet key function prevents unauthorized persons from opening the glove compartment.



Fig. 31 Center console: button for valet key function

### Activating and deactivating the function

- ▶ Insert the *master key* into the ignition lock and switch on the ignition.
- ▶ Press the **VALET** button ⇒ *fig. 31* to activate / deactivate the function as desired. The indicator light in the button illuminates when the function is active.
- ▶ Remove the master key from the ignition lock.
- ▶ Hand over only the *valet key* ⇒ *page 38, fig. 27* to the person who will take charge of the vehicle.

When the function is switched on, the buttons for opening the rear lid and glove compartment have no function. The vehicle can be driven and locked and unlocked with the master key.

### Tips

Be sure to activate the function before handing over the valet key to someone else. The valet key only fits the lock in the driver's door and the ignition lock.

## Power locking system

### General description

The power locking system locks or unlocks all doors and the rear lid simultaneously.

The power locking system in your vehicle incorporates the following functions:

- Central locking function
- Selective unlock feature ⇒ *page 44*
- Remote control feature ⇒ *page 38*
- Convenience key\* ⇒ *page 49*
- Anti-theft alarm system ⇒ *page 50*

All the doors and the rear lid are locked by the central locking system when you lock the vehicle. You can set whether generally only the driver's door or all doors and the rear lid should be unlocked when you open the vehicle in the MMI menu **Central locking** to suit your individual desires ⇒ *page 44*.

### Unlocking the vehicle

You can unlock the vehicle from outside either by using the remote control **or** by inserting and turning the key in the driver's door lock. When you **unlock** your vehicle:

- The anti-theft alarm system is deactivated briefly.
- The vehicle interior lights illuminate for approximately 30 seconds.
- All turn signal lights will flash twice when the car is unlocked.
- After unlocking the vehicle, you have 60 seconds to open a door or the rear lid. After 60 seconds, the vehicle automatically locks and the anti-theft alarm system activates again.

The rear lid can be locked or unlocked either by using the remote control **or** by inserting and turning the key in the driver's door lock. Unlocking the vehicle with the remote control will only *unlock* the rear lid, to *open* it, the lid handle needs to be pressed.

### Locking the vehicle

You can lock the vehicle from outside either by using the remote control **or** by inserting and turning the key in the driver's door lock.

When you **lock** the vehicle:

- All doors and the rear lid are locked.
- All turn signal lights will flash once when the car is locked.
- The anti-theft alarm system is activated. The horn of the anti-theft alarm system will sound and the anti-theft alarm system

readiness light, located in the upper part of the driver's door panel, will start to blink.

- The vehicle interior lights turn off.

### Unlocking and locking with Convenience key\*

On vehicles which are equipped with the **Convenience key\*** authorization system, the doors are unlocked *without a key* by means of a proximity sensor in the door handle. The doors are similarly locked *without a key* using the locking button. Each door has a proximity sensor and a locking button.

### Automatic locking

The automatic locking feature locks all the vehicle doors and the rear lid when you drive faster than 9 mph (15 km/h). This function can be turned on and off in the MMI **Central locking** Menu ⇒ *page 44*.

You can unlock the vehicle from the inside by:

- removing the key from the ignition switch (the vehicle will automatically unlock itself) or
- pressing the unlock part of the power lock switch  or
- pulling the door handle (twice to open the rear doors).

### Unintentionally locking yourself out

In the following cases there are safeguards to prevent you locking your remote master key in the vehicle:

- The vehicle does not lock with the power locking switch ⇒ *page 44* if the driver's door is open.
- On vehicles with Convenience key\*, if the most recently used master key is in the luggage compartment, the rear lid is automatically unlocked again after it is closed.

Do not lock your vehicle with the **remote master key** or **Convenience key\*** until all doors and the rear lid are closed. In this way you avoid locking yourself out accidentally.

### **WARNING**

- When you lock your vehicle from outside, nobody - especially children - should remain inside the vehicle. Remember, when you lock the vehicle from the outside the windows cannot be opened from the inside.
- When you leave the vehicle, always remove the ignition key and take it with you. This will prevent passengers (children, for example) from accidentally being locked in the vehicle should they accidentally press the power locking switch in the front doors.
- Do not leave children inside the vehicle unsupervised. In an emergency it would be impossible to open the doors from the outside without the key.

### **Tips**

- In the event of a crash with airbag deployment all locked doors will be automatically unlocked to give access to the vehicle occupants from the outside.
- If the power locking system should malfunction, you can lock each door individually using the vehicle key ⇒ *page 45*.
- If the power locking system should fail, you can still open the fuel tank flap in an emergency ⇒ *page 261*.
- You are well advised not to keep valuables inside an unattended vehicle, visible or not. Even a properly locked vehicle cannot provide the security of a safe.

## Unlocking and locking the vehicle with the remote control

How the remote control works.



Fig. 32 Remote control: function buttons

Either the driver's door only or the entire vehicle will unlock when the unlock button (A) is pressed once, depending on the settings in the MMI **Central locking** menu ⇒ page 44.

### To unlock the vehicle

- ▶ Press button (A).
- ▶ Press button (A) *two times* within two seconds **to unlock all doors and the rear lid.**

### To lock the vehicle

- ▶ Press button (B) ⇒ in *General description on page 42.*
- ▶ Watch that all turn signal lights flash once.

### To unlock rear lid only

- ▶ Press button (C) for approximately one second.

### PANIC Button

- ▶ Push the red button (D) to activate the panic function. The horn sounds and the turn signals flash.
- ▶ Push the button (D) again to deactivate the panic function.

On vehicles with Convenience key\*, the selector lever must be in the P position, otherwise the vehicle cannot be locked.

## WARNING

Read and follow all WARNINGS ⇒ in *General description on page 42.*

## Tips

- In order to make sure the locking function is working, you should always keep your eye on the vehicle to make sure it is properly locked.
- Do not use the remote control if you are inside the car, otherwise you may unintentionally lock the vehicle, and then you would set off the anti-theft alarm when you try to start the engine or open a door. In case this happens anyhow, push the unlock button .
- Use the panic function only if you are in an emergency situation.

## Operating locks with the key

To lock and unlock the vehicle from the outside, turn the key in the lock of the driver's door.

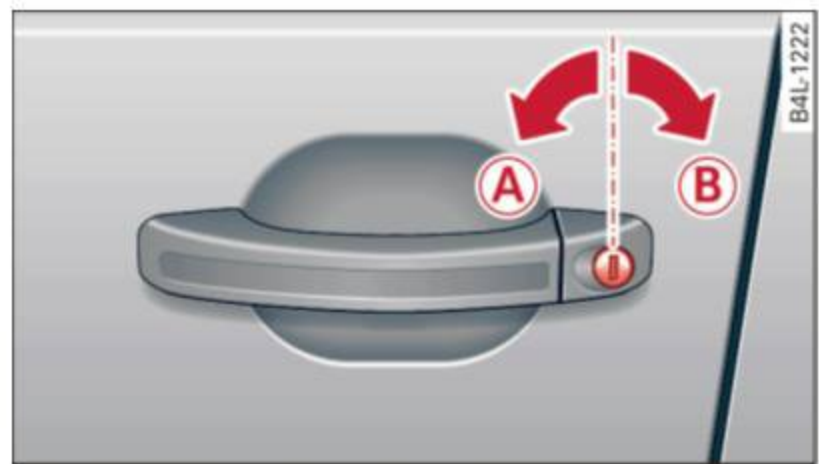

Fig. 33 Key turns for opening and closing.

### To unlock the vehicle

- ▶ Insert the key into the lock of the driver's door.
- ▶ Turn the key *one time* to position (A) to unlock the driver's door.
- ▶ Turn the key *two times* to position (A) ⇒ fig. 33 to unlock all doors and the rear lid.

### To lock the vehicle

- ▶ Close all windows and doors properly.
- ▶ Turn the key in the lock of the driver's door to the lock position (B) ⇒ in *General description on page 42.*

**! WARNING**



Read and follow all WARNINGS ⇒ **!** in *General description on page 42.*

**Settings in the MMI**



The driver can determine the functions for power locking in the MMI.

- ▶ Select: **CAR** function button > **Systems\*** control button > **Central locking**. Or
- ▶ Select: **CAR** function button > **Car systems\*** control button > **Vehicle settings > (Central locking)\***.

**Passenger's door\***, **Left rear door\***, **Right rear door\***, **Trunk lid/tailgate\*** - You can specify which doors should unlock when you unlock the vehicle.

- If you select **On** and then press the  button on the remote control key, the corresponding door will unlock.
- If you select **Off** and then press the  button on the remote control key, the corresponding door will not unlock. If you press the  button twice, all doors and the luggage compartment will unlock. When locking the vehicle, all of the doors and the luggage compartment lock automatically.

**Unlock doors\*** - You can specify if all doors or only the driver's door should unlock when unlocking the vehicle.

- If you select **All** and press the  button on the remote control key, all of the doors and the luggage compartment will unlock.
- If you select **Driver** and then press the  button on the remote control key, only the driver's door will unlock. If you press the  button twice, all doors and the luggage compartment will unlock. When locking the vehicle, all of the doors and the luggage compartment lock automatically. In vehicles with a convenience key\*, only the door whose handle you pull will unlock.

**Auto locking/Lock when driving** - If you select **On**, the doors and the luggage compartment will lock automatically.

**i Tips**

The central locking settings are stored in the remote control key.

**Locking and unlocking the vehicle from inside**



The vehicle can be locked or unlocked from the inside using the power locking switches.



Fig. 34 Front doors: power locking switch



Fig. 35 Rear doors: power locking switch

- ▶ Press the button  to unlock the vehicle.
- ▶ Press the button  to lock the vehicle ⇒ **!**.

You will find a power locking switch in each door. You can **lock** and **unlock** the vehicle using the switches in the driver's or passenger's door ⇒ *fig. 34*. You can only **lock** the vehicle using the switches in the rear doors ⇒ *fig. 35*. If you lock the vehicle using the power locking switch, please note the following:

- You cannot open the doors or the rear lid from the *outside* (increased security, for example when you are stopped at a red light).
- The diodes in the power locking switches illuminate when all the doors and the rear lid are closed and locked.

- Front doors: you can unlock and open the doors from the inside by pulling on the door handle.
- Rear doors: pull the door handle *once* to release the lock. Pull the handle *again* to open the door.
- If the driver's door is opened (after you have locked the vehicle from the inside using the power locking switch), the door will remain unlocked to prevent you from locking yourself out of your vehicle. After you close the door, you have to lock the driver's door again.
- If you have a crash and the airbag is activated, the doors automatically unlock.

### WARNING

- If you use the power locking switch with the doors closed, remember that all the vehicle doors will lock.
- Locked doors make it more difficult for emergency workers to get into the vehicle, which puts lives at risk. Do not leave anyone behind in the vehicle, especially children.

### Emergency locking

If the central locking system fails (power supply), each door has to be locked separately.

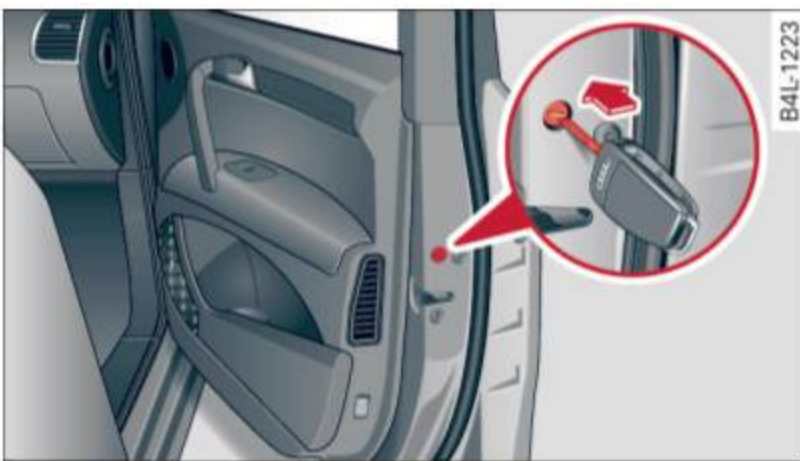

Fig. 36 Emergency locking of the front passenger's door

An emergency locking mechanism is integrated in the edge of the passenger's door and in the rear doors (only visible when the door is open).

- ▶ Open the door.

- ▶ Pull the protective cover out of the hole ⇒ *fig. 36*.
- ▶ Insert the key into the inner slot and turn it to the right (right-side doors) or the left (left-side door) as far as it can go.

After you close the door, you will no longer be able to open it from the outside.

The door can be opened from the inside by pulling once respectively twice (rear doors) on the door handle. If the child safety lock is engaged in one of the rear doors, the door has to be opened from the outside after pulling on the handle once from the inside.

## Rear lid

### Opening and closing rear lid

You can open the rear lid from inside the vehicle using a switch in the driver's door.





Fig. 37 Driver's door: remote rear lid release



Fig. 38 Position of handle in the rear lid

### Opening the rear lid

- ▶ Press the middle button  on the remote control master key, or
- ▶ Press the unlock button  in the driver's door ⇒ *fig. 37*, or
- ▶ Press the handle on the rear lid ⇒ *fig. 38*.

- ▶ The rear lid unlocks automatically and opens slightly.
- ▶ Lift the rear lid.

### Closing the rear lid

- ▶ Pull the rear lid down and allow it to drop gently. The lid is then closed automatically ⇒ ⚠.

#### ⚠ WARNING

- After closing the rear lid, always pull up on it to make sure that it is properly closed. Otherwise it could open suddenly when the vehicle is moving.
- To help prevent poisonous exhaust gas from being drawn into the vehicle, always keep the rear lid closed while driving. Never transport objects larger than those which fit completely into the luggage area, because then the rear lid cannot be fully closed.
- Never leave your vehicle unattended especially with the rear lid left open. A child could crawl into the car through the luggage compartment and pull the lid shut, becoming trapped and unable to get out. To reduce the risk of personal injury, never let children play in or around your vehicle. Always keep the rear lid as well as the vehicle doors closed when not in use.
- Always ensure that no one is within range of the rear lid when it is moving, in particular close to the hinges - fingers or hands can be pinched.

#### **i** Tips

- If the rear lid is open or not properly closed when the ignition is turned on, the door and rear lid warning ⇒ page 22 appears in the instrument cluster display.
- Should you not be able to open the rear lid as described, make sure the valet key function is not activated ⇒ page 41.

### Automatic rear lid/trunk lid operation

Applies to vehicles: with automatic rear lid/trunk lid operation

*The trunk lid can be opened and closed automatically.*







Fig. 39 Driver's door: Unlocking the rear lid



Fig. 40 Locking switch in the rear lid

### Opening rear lid

- ▶ Press the middle button  on the remote key for at least one second, or
- ▶ Press the unlock button  in the driver's door ⇒ fig. 39, or
- ▶ Press the handle on the rear lid ⇒ page 45, fig. 38.
- ▶ The opening process **is stopped immediately** if the middle button  on the remote key is pressed again for at least one second or the unlock button  in the driver's door is pressed again or the handle in the rear lid is pressed again.
- ▶ *Middle button in the remote key and unlock button in the driver's door:* The opening process is continued by pressing one of the buttons again.
- ▶ *Handle in the rear lid:* the rear lid is closed again by pressing the handle again ⇒ ⚠.

### Closing rear lid/trunk lid

- ▶ Press the close button in the open rear lid ⇒ *fig. 40*. The trunk lid moves to the closed position by itself and soft close locks it automatically ⇒ .
- ▶ The closing process **is stopped immediately** if the close button in the rear lid is pressed again.
- ▶ By pushing the button again, the rear lid is opened again.

### Saving the opening angle of the rear lid

- ▶ Bring the rear lid manually or automatically to the desired opening position and leave it in this position.
- ▶ Press the button in the rear lid ⇒ *fig. 40* for at least four seconds in order to save the desired opening position. The position can only be saved starting at a certain level.

#### WARNING

- Never close the rear lid inattentively or without checking first. Although the closing force of the rear lid is limited, you can still seriously injure yourself or others.
- Always ensure that no one is within range of the rear lid when it is moving, in particular close to the hinges and the upper and lower edges - fingers or hands can be pinched.
- To help prevent poisonous exhaust gas from being drawn into the vehicle, always keep the rear lid closed while driving. Never transport objects larger than those which fit completely into the luggage area, because then the rear lid cannot be fully closed.
- Never leave your vehicle unattended especially with the rear lid left open. A child could crawl into the car through the luggage compartment and pull the lid shut, becoming trapped and unable to get out. To reduce the risk of personal injury, never let children play in or around your vehicle. Always keep the rear lid as

well as the vehicle doors closed when not in use.

- If there is a luggage rack or bicycle rack mounted on the rear lid, it may not be able to open completely or an opened rear lid may close by itself because of the added weight. So the open rear lid must be supported or the weight must be removed from the luggage rack first.

#### Tips

- If the rear lid is open or not properly locked when the ignition is turned on, the door and rear lid warning ⇒ *page 22* appears in the instrument cluster display.
- The automatic rear lid opening/closing process can be stopped by holding the rear lid with your hand. The lid can then be further opened/closed by hand.
- If there is a mechanical problem with the automatic rear lid **opening process** or there is an obstruction, the process is stopped immediately.
- If there is a mechanical problem with **automatic closing** for the rear lid or there is an obstruction, it opens again slightly right away. Check to see why the rear lid could not be closed before attempting to close it again.
- If the rear lid on a locked vehicle is unlocked with the middle button  on the remote key, the rear lid is automatically locked again immediately after closing. This is indicated by the turn signals blinking.
- The following applies to vehicles equipped with the Convenience key\* feature: if the remote control key is left in the luggage compartment, luggage compartment will automatically unlock itself after you lock the vehicle. This prevents you from unintentionally locking your key in the luggage compartment.
- If the vehicle battery charge drops below a certain level, you can still open or close the rear lid manually, however, you will need to apply more force to close it.

– As soon as the electrical connection to the trailer socket is completed on vehicles with a factory installed towing hitch, or a trailer hitch that was installed later according to factory specifications, the automatic rear lid function can only be operated via the handle in the rear lid.

### Rear lid emergency unlocking

If the rear lid cannot be opened, an emergency release is provided.



Fig. 41 Section of the luggage compartment: Access to emergency release



Fig. 42 Section of the luggage compartment: Emergency release

- ▶ Tilt the seatback forward.
- ▶ Move into the trunk.
- ▶ Take the screwdriver from the vehicle tool kit. As an alternative, you can also use the vehicle key.
- ▶ Put the flat side of the screw driver into the recess and pry the cover up ⇒ fig. 41 -Arrow-.
- ▶ Press the lever in the direction of the arrow ⇒ fig. 42 to unlock the rear lid.

## Child safety lock

### Power child safety lock for the rear doors



The power child safety lock  prevents the rear doors from being opened from the inside.



Fig. 43 Section from driver's door: controls

The rear doors are equipped with a power child safety lock. It is operated with the two safety buttons  in the driver's door ⇒ fig. 43.

- ▶ Press the left and/or right safety button to disable the rear power window(s) and prevent the respective rear door from being opened from the inside. The LED in the button will light up when the child safety lock is turned **on**.
- ▶ Press the illuminated button again to turn the child safety features **off**.

When the child safety lock is activated, the interior door opening lever is inoperative; the door can only be opened from the outside. In addition, the window regulator for that door is also inoperative when the child safety lock is activated.

If the child safety lock has been activated on one or both sides, the buttons in the rear for the Panoramic sliding sunroof\* are disabled.

If the child safety lock has been activated on the left **and** on the right side, the rear controls are locked on vehicles with rear air-conditioning\*. Dashes “---” are shown in the displays for the rear climate controls, and the rear air-conditioning can only be operated from the climate controls in the cabin ⇒ page 97.

**i Tips**

- In order to activate the child safety lock on the left and the right side, you have to press the two safety buttons in succession.
- Make certain that the check light comes on in the corresponding safety switch when the child safety lock is activated.

## Convenience key

**Description**

Applies to vehicles: with Convenience key

*Access and vehicle operation based on: Master key remains in driver's pocket.*

The Convenience key vehicle authorization system allows *keyless* unlocking, locking and starting of the vehicle. You only have to carry the master key on your person.

It makes no difference whether the master key is in your jacket pocket or in your brief case. As soon as you approach your vehicle, the Convenience key recognizes the request for access, checks for authorization and enables the following functions:

- Unlocking the vehicle ⇒ *page 49*.
- Locking the vehicle ⇒ *page 50*.
- Switching on ignition and starting the engine by pressing the **START** button; the master key does not have to be in the ignition switch ⇒ *page 107*.

**! WARNING**

- When you lock your vehicle from outside, nobody - especially children - should remain inside the vehicle. Remember, when you lock the vehicle from the outside the windows cannot be opened from the inside.
- When you leave the vehicle, always remove the ignition key and take it with you. This will prevent passengers (children, for example) from accidentally being locked in the vehicle should they acci-

- dentally press the power locking switch in the front doors.
- Do not leave children inside the vehicle unsupervised. In an emergency it would be impossible to open the doors from the outside without the key.

**i Tips**

- In order for the Convenience key to function, you must always carry the master key with you.
- In order to be able to unlock or lock the vehicle, the authorized master key must be within a range of about 5 feet (1.5 meters) from the door or the rear lid.
- Of course, you can still unlock and lock your vehicle using the buttons on the master key. The selector lever must be in the P position.
- For Declaration of Compliance to United States FCC and Industry Canada regulations ⇒ *page 328*.

**Unlocking the vehicle**

Applies to vehicles: with Convenience key

*The doors and the rear lid can be unlocked without operating the master key.*

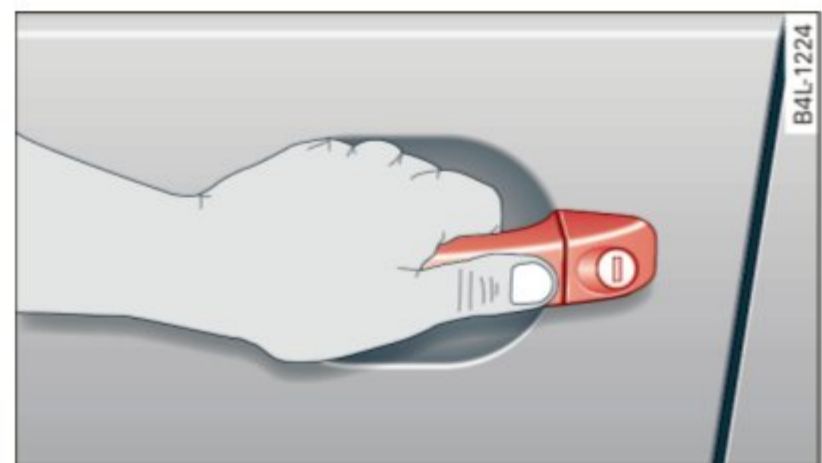

**Fig. 44** Convenience key: unlocking vehicle door

- ▶ Take hold of the door handle. The door is unlocked automatically.
- ▶ Pull the handle to open the door.

A door is unlocked as soon as you approach the door handle and the system recognizes an authorized master key. The vehicle can be unlocked at any door. The authorized master key only has to be within a range of about 5 feet (1.5 meters) from the respective door. ▶

When a door is unlocked, the driver's door is always unlocked as well. It depends on the settings in the central locking menu in the MMI whether the entire vehicle is unlocked or only certain doors ⇒ *page 44*.

### **i** Tips

If your vehicle has been standing for an extended period, please note the following:

- The proximity sensors are deactivated after a few days to save power. You then have to pull on the door handle once to unlock the vehicle and a second time to open the vehicle.
- To prevent the battery from being discharged and to preserve your vehicle's ability to start for as long as possible, the energy management system gradually switches off unnecessary convenience functions. It is possible that you will not be able to unlock your vehicle using these convenience functions.

### **Locking the vehicle**

Applies to vehicles: with Convenience key

*The vehicle can be locked without operating the master key.*

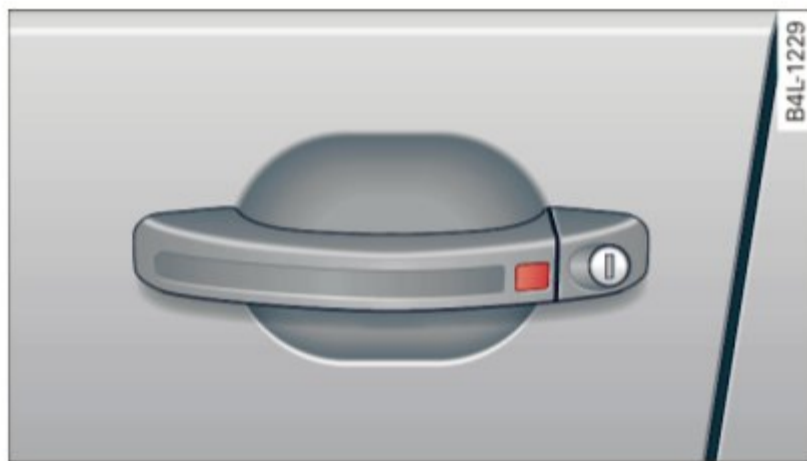

**Fig. 45** Convenience key: Locking the vehicle

- ▶ Move the selector lever to the P position.
- ▶ Press the locking button in the door handle to lock the vehicle ⇒ . Do not reach inside the door handle.

The vehicle can be locked at any door. The authorized master key only has to be within a range of about 5 feet (1.5 meters) from the particular door.

The selector lever must be in the P position, otherwise the vehicle cannot be locked.

### **WARNING**

- When you lock your vehicle from outside, nobody - especially children - should remain inside the vehicle. Remember, when you lock the vehicle from the outside the windows cannot be opened from the inside.
- When you leave the vehicle, always remove the ignition key and take it with you. This will prevent passengers (children, for example) from accidentally being locked in the vehicle should they accidentally press the power locking switch in the front doors.
- Do not leave children inside the vehicle unsupervised. In an emergency it would be impossible to open the doors from the outside without the key.

### **i** Tips

It is not possible to re-open the door for a brief period directly after closing it. This allows you to ensure that the doors are properly locked.

## **Anti-theft alarm system**

*The anti-theft alarm triggers an alarm if anyone attempts to break into the vehicle.*

The anti-theft alarm system triggers an audible alarm and turns on the emergency flasher if an unauthorized interference with the vehicle is sensed by the system.

### **How is the anti-theft alarm system switched on?**

The anti-theft alarm system is switched on when you lock the vehicle. The system is activated approximately 30 seconds after the vehicle is locked. The indicator light on top of the door trim starts flashing rapidly for 30 seconds and then blink slowly. ▶

### How is the anti-theft alarm system switched off?

The anti-theft alarm system is switched off only when you unlock your vehicle. If you do not open a door within 60 seconds after you have unlocked with the remote control, the vehicle will lock itself again automatically.

### When will the anti-theft alarm system be triggered?

When the vehicle is locked, the alarm system monitors and protects the following parts of the vehicle:

- engine compartment
- luggage compartment
- doors
- ignition

When the system is activated, the alarm will be triggered if one of the doors, the engine hood or the rear lid are opened, or if the ignition is turned on. The anti-theft alarm system will also go off when the battery is disconnected.

You can also trigger the alarm by pressing the PANIC button on your remote control. This will alert other people in case of emergency. Press the **PANIC** button again to turn off the alarm.

### How is the anti-theft alarm switched off when triggered?

The alarm system is switched off when you unlock the vehicle or when the ignition is switched on. The alarm will also switch itself off when it comes to the end of its cycle.

### Emergency flasher and horn

The emergency flasher will blink briefly and the horn sounds when the doors, engine hood and rear lid are properly closed.

If the emergency flashers do not blink, or the horn does not sound, check the doors, engine hood and rear lid to make sure they are properly closed. If you close a door, the hood or the rear lid with the anti-theft alarm switched on, the emergency flashers will blink and the

horn will sound only after you have closed the door or lid.

#### **i** Tips

For the anti-theft alarm system to function properly, make sure all vehicle doors and windows are closed before leaving the vehicle.

## Power windows

### Controls

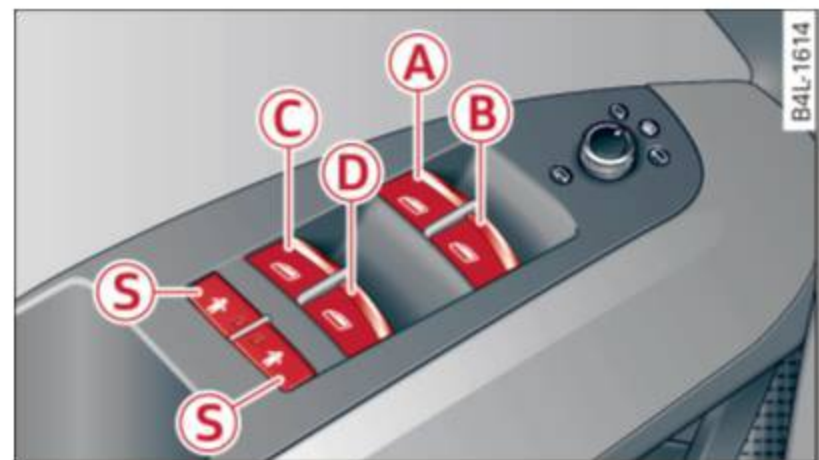

Fig. 46 Driver's door: power window switches

### Switches for front door windows

- A** operates the window in the driver's door.
- B** operates the window in the front passenger's door.

### Switches for rear windows

- C** operates the left rear window.
- D** operates the right rear window.

### Safety switch

- S** Safety switch for rear window operation.

#### **!** WARNING

- Do not leave children unattended in the vehicle, especially with access to vehicle keys. Unsupervised use of the keys can result in starting of the engine and use of vehicle systems such as power windows, etc. which could result in serious injury.
- Remember – you can still open or close the power windows for about ten minutes after the ignition is switched off. Only when either of the front doors are

opened are the power windows switched off.

- Be careful when closing the windows. Check to see that no one is in the way, or serious injury could result!
- Always remove the ignition key whenever you leave your vehicle.
- If you lock your vehicle from the outside, no one, especially children, should remain in the vehicle.
- Do not stick anything on the windows or the windshield that may interfere with the driver's field of vision.

### Tips

In addition to the switches in the driver's door there is a separate switch in each door for the power window in that door ⇒ *page 53, fig. 47.*

### Switches in the driver's door

*The driver can operate all windows.*

If the respective switch is pushed or pulled the window will open or close. The power window switches have a **two-position function**:

#### Opening the windows

- ▶ Push the switch to the **first stop** and hold it there until the window has lowered to the desired position.
- ▶ Push the switch briefly to the **second stop**: the window will automatically open all the way.



#### Closing the windows



- ▶ Pull the switch up to the **first stop** and hold it there until the window has risen to the desired position.
- ▶ Pull the switch quickly to the **second position**: the window will automatically close all the way ⇒  *in Controls on page 51.*

#### Activating/deactivating the rear windows

- ▶ Press the left  switch ⇒ *page 51, fig. 46* to **deactivate** only the window regulator in the

**left** door. The indicator light in the switch illuminates.

- ▶ Press the right  switch ⇒ *page 51, fig. 46* to **deactivate** only the window regulator in the **right** door. The indicator light in the switch illuminates.
- ▶ Press the  switch again to reactivate the window regulator. The indicator light in the switch goes out.

If you press both  switches  in succession, the following functions are switched off in the rear of the vehicle:

- The window regulator switches in the rear doors.
- The buttons for the Panoramic sliding sunroof\*.
- On vehicles with rear climate control\*, operation from the rear is blocked. Dashes “---” are shown in the displays for the rear climate controls, and the rear air-conditioning can only be operated from the climate controls in the cabin ⇒ *page 97.*
- If **only the left**  switch was pressed, the window regulator in the **left rear door** and the buttons in the rear for the Panoramic sliding sunroof\* are deactivated. In addition, the door is locked.
- If **only the right**  switch was pressed, the window regulator in the **right rear door** and the buttons in the rear for the Panoramic sliding sunroof\* are deactivated. In addition, the door is locked.

This feature has been provided for the safety of small children riding in the rear of the vehicle.

### Tips

- The windows can still be opened and closed for about ten minutes after the ignition has been turned off. The power windows are not shut off until one of the front doors is opened.
- In order to activate the child safety lock on the left and the right side, you have to press the two safety switches in succession. Make certain that the check light comes on the corresponding safety

switch when the child safety lock is activated.

### Switch in the front passenger's door and on the rear doors



Fig. 47 Switch location front passenger's door

The power window switch has a **two-position function**:

#### Opening the windows

- ▶ Press the switch to the **first position** and hold it until you have opened the window as far as you want.
- ▶ Press the switch quickly to the **second position** and the window will automatically open all the way.

#### Closing the windows

- ▶ Pull the switch to the **first position** and hold it until you have closed the window as far as you want.
- ▶ Pull the switch quickly to the **second position** and the window will automatically close all the way.

#### **i** Tips

The windows can still be opened and closed for about ten minutes after the ignition has been turned off. The power windows are not shut off until one of the front doors is opened.

### Convenience close/open feature with the lock in the driver's door

You can close or open the windows from outside when you lock or unlock your car with the key in the driver's door lock.

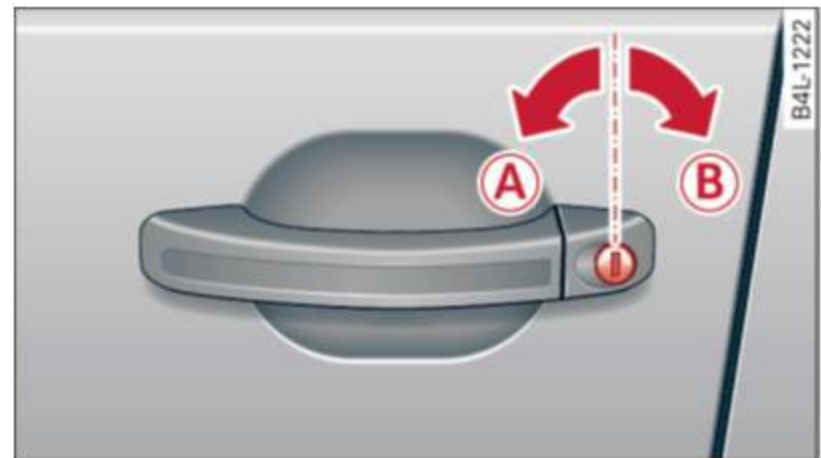



Fig. 48 Key turns for opening and closing

#### Closing windows

- ▶ Insert the key into the lock of the driver's door.
- ▶ Make sure that the windows are not blocked ⇒ .
- ▶ Turn and hold the key in the lock position **B** ⇒ *fig. 48* until the windows and the Panoramic sliding sunroof\* with the power sun blind are completely closed.

#### Opening windows

- ▶ Insert the key into the lock of the driver's door.
- ▶ Turn and hold the key in the open position **A**.

The automatic close/open function will cease if the key is returned to its original position.

#### WARNING

- Be careful when closing the windows. Check to see that no one is in the way, or serious injury could result!
- Always read and heed WARNING ⇒  in *General description on page 42*.

### Reactivating the system after battery disconnection

If the vehicle battery is disconnected and then reconnected, the automatic closing and opening function will not work until it is reactivated. To reactivate this feature, perform the following steps:

#### Reactivating close/open feature

- ▶ Pull and hold the power window switch until the window is completely closed.
- ▶ Release the switch.
- ▶ Pull the switch again for one second. The automatic closing/opening is now reactivated.

## Panoramic sliding sunroof

### Description

Applies to vehicles: with Panoramic sliding sunroof

The Panoramic sliding sunroof is comprised of two individual glass roof segments, which can be adjusted electrically independently of each other.

The front segment can be tilted and slid open. The rear segment can be tilted, but it cannot be slid open.

The Panoramic sliding sunroof is operated by the driver or passenger when the ignition is on with a rotary switch (for the front roof segment) and a rocker switch (rear roof segment).

After the ignition has been switched off, the Panoramic sliding sunroof can still be opened or closed for about 10 minutes. However, as soon as the driver's or passenger's door is opened, the switches for the Panoramic sliding sunroof are inoperative.

### ! Note

You should always close the Panoramic sliding sunroof when you leave your vehicle. Sudden rain can drench the interior equipment and damage the electronic convenience features in your vehicle.

### i Tips

If you park your vehicle in the sun, we recommend that you close both sun blinds ⇒ page 56.

### Tilting/sliding open Panoramic sliding sunroof

Applies to vehicles: with Panoramic sliding sunroof



Fig. 49 Section of front headliner: Switch for Panoramic sliding sunroof

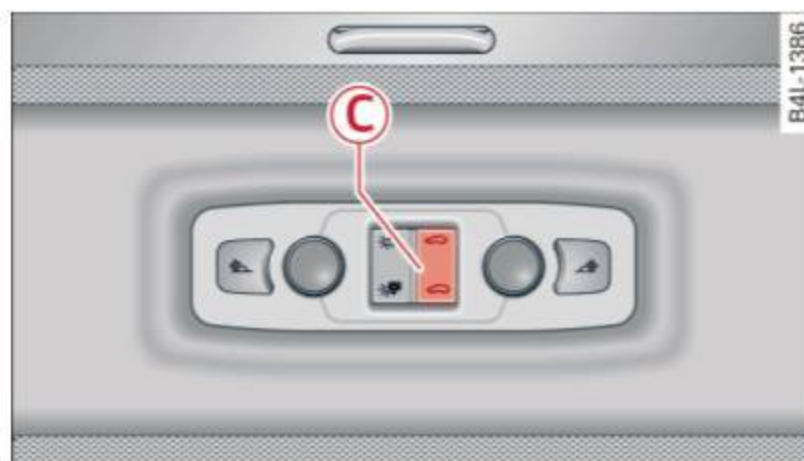

Fig. 50 Section of headliner in rear: Switch for Panoramic sliding sunroof

#### Tilting front roof segment

- ▶ Press switch ⇒ fig. 49 (A) in the initial position (O) **briefly** to open the roof segment completely. Press it **longer** to set an intermediate position manually.

#### Tilting rear roof segment

- ▶ Tap the rocker switch ⇒ fig. 49 (B) or ⇒ fig. 50 (C) in the rear area ⇐ **briefly**, the roof segment tilts up automatically.
- ▶ To set an intermediate position manually, press the rocker switch (B) or (C) in the rear area ⇐ **until** the roof segment has reached the desired tilted position.

## Opening front roof segment to comfort setting

- ▶ Turn the rotary switch ⇒ *fig. 49* (A) to position (1), you will feel the switch engage. The roof segment is slid open only to a comfort position with low wind noise. This is the recommended standard setting for normal driving conditions.

## Sliding front roof segment fully open

- ▶ Rotate and hold the switch (A) in position (2) until the roof segment has reached the desired position. There may be increased wind noise in this position.

### **i** Tips

- In position (2), the switch jumps back to position (1) again as soon as the switch is released.
- When driving with the Panoramic sliding sunroof open, open the front roof segment to the comfort setting to minimize wind noise.

## Closing Panoramic sliding sunroof

Applies to vehicles: with Panoramic sliding sunroof

### Closing tilted front roof segment

- ▶ Pull the switch ⇒ *page 54, fig. 49* (A) and **hold it until** the roof segment has reached the desired position.
- ▶ Pull the switch **briefly** to close the roof segment automatically. By activating the switch briefly again, the roof segment can be stopped in any position ⇒ ⚠.

### Closing front roof segment when slid open

- ▶ Rotate switch ⇒ *page 54, fig. 49* (A) to position (0) to close the roof segment ⇒ ⚠. To move to an intermediate position, rotate the switch to the corresponding click-stop.

### Closing tilted rear roof segment

- ▶ Tap the rocker switch ⇒ *page 54, fig. 49* (B) or ⇒ *page 54, fig. 50* (C) in the front area ⇐ **briefly** to close the roof segment completely ⇒ ⚠.

- ▶ To set an intermediate position manually, press the rocker switch in the front area ⇐ **until** the roof segment has reached the desired tilt position ⇒ ⚠.

### **!** WARNING

Improper use of the Panoramic sliding sunroof can cause serious personal injury.

- Be careful when closing the Panoramic sliding sunroof. Not paying attention could cause you or others to be trapped and injured as the Panoramic sliding sunroof closes.
- Always take the key with you when you leave the vehicle to prevent injuries caused by the Panoramic sliding sunroof closing
- Never leave children or persons requiring assistance alone in the vehicle, especially when they could access the vehicle keys. Unsupervised use of the keys can result in the engine being started or use of vehicle systems such as the power windows, etc. which could result in serious injury. The doors could be locked with the remote key, delaying help in an emergency.
- The Panoramic sliding sunroof will continue to operate until the ignition key has been removed and one of the front doors has been opened.

## Convenience closing feature

Applies to vehicles: with Panoramic sliding sunroof

*The Panoramic sliding sunroof can be closed from outside with the key in the driver's door lock.*

- ▶ Insert the key into the driver's door lock.
- ▶ Turn and hold the key in the lock position (B) ⇒ *page 43, fig. 33* until the Panoramic sliding sunroof is completely closed ⇒ ⚠ *in Closing Panoramic sliding sunroof on page 55.* The power sun blind is also closed. ▶

**! WARNING**

Be careful when closing the Panoramic sliding sunroof. Not paying attention could cause you or others to be trapped and injured as the Panoramic sliding sunroof closes.

**Opening and closing sunshade**

Applies to vehicles: with Panoramic sliding sunroof



Fig. 51 Section of front headliner: Switch for sunshade



Fig. 52 Section of headliner in rear: Switch for sunshade

The two segments of the Panoramic sliding sunroof are each equipped with a sunshade for protection against the sun's rays. The front shade is power operated, the rear shade is opened and closed manually. To prevent the vehicle interior from heating up, you should close both sunshades when you park your vehicle in the sun.

**Opening and closing front sunshade**

- ▶ Tap the rear ☀ of the rocker switch ⇒ *fig. 51* or the rocker switch for rear-seat passengers ⇒ *fig. 52* **briefly** to open the sunshade fully.
- ▶ Tap the front ☀ of the rocker switch **briefly** to close the sunshade fully ⇒ **!**.

- ▶ To set an intermediate position manually, press the front or rear of the rocker switch (depending on the position of the shade) **until** the desired position is reached ⇒ **!**.

**Opening and closing rear sunshade**

- ▶ Hold the sunshade by the grip and push it to the desired position.

**! WARNING**

Never close the sunshade without paying attention or checking - danger of injury!

**Emergency closing of the Panoramic sliding sunroof**

Applies to vehicles: with Panoramic sliding sunroof

If the Panoramic sliding sunroof detects an object in its path when it is closing, it will open again automatically. In this case, you can close the roof with the power emergency closing function.

**Emergency closing of front roof segment**

- ▶ Turn the switch ⇒ *page 54, fig. 49* **(A)** to the normal position **(0)**.
- ▶ Within five seconds after the sunroof opens automatically, pull the switch until the roof segment closes.

**Emergency closing of rear roof segment**

- ▶ Within five seconds after the sunroof opens automatically, press the front ☀ of the rocker switch ⇒ *page 54, fig. 49* **(B)** until the roof segment closes.

## Clear vision

### Lights

#### Switching the headlights on and off

In the "AUTO" position, a light sensor automatically switches the head- and taillights on and off in response to light conditions.



Fig. 53 Instrument panel: light switch

The light switch must not be overturned past the stops in **either** direction.

#### Switching on automatic headlight control

- ▶ Turn the light switch to **AUTO** ⇒ *fig. 53*.

#### Switching on the side marker lights

- ▶ Turn the light switch to ☞☞.

#### Switching on the headlights and high beam

- ▶ Turn the light switch to ☞☞.
- ▶ Push the high beam lever forward towards the instrument panel ⇒ *page 60*.

#### Switching off the lights

- ▶ Turn the light switch to **O**.

The headlights only work when the ignition is switched on. While starting the engine or when switching off the ignition, the headlights will go off and only the side marker lights will be on.

After starting the engine, the headlights are automatically adjusted\* to the load and angle of the vehicle (for example, during acceleration, braking). This prevents oncoming traffic from experiencing unnecessary headlight glare from your headlights.

If the system is not operating properly, a warning symbol in the Auto-Check Control is displayed ⇒ *page 36*.

With the side marker lights or headlights switched on, the symbol next to the light switch illuminates ☞☞.

#### Daytime running lights

- **USA models:** The daytime running lights will come on automatically when the ignition is turned on and the light switch ⇒ *fig. 53* is in the **O** position or the **AUTO** position (only in daylight conditions). The **Daytime running lights** function can be turned on and off in the MMI menu **Exterior lighting** ⇒ *page 58*.
- **Canada models:** The daytime running lights will come on automatically when the ignition is turned on and the light switch ⇒ *fig. 53* is in the **O** position or the **AUTO** position (only in daylight conditions) ⇒ ⚠.

#### Automatic headlight control

In the switch position **AUTO** the **automatic headlight control** is turned on. The low beams and tail lights are turned on automatically through a light sensor as soon as ambient brightness (e.g. when driving into a tunnel) falls below a value preset at the factory. When ambient brightness increases again, the low beams are turned off again automatically ⇒ ⚠.

In the **AUTO** position the low beams are switched off automatically when the ignition is turned off.

#### Light Sensor Malfunction

In the event of a light sensor malfunction, the driver is notified in the instrument cluster display:

#### Automatic headlights / automatic wipers defective

For safety reasons the low beams are turned on permanently with the switch in **AUTO**. However, you can continue to turn the lights on and off using the light switch. Have the

light sensor checked as soon as possible at an authorized Audi dealer or qualified workshop.

### WARNING

- Daytime running lights and automatic headlights are only intended to assist the driver. They do not relieve the driver of his responsibility to check the headlights and to turn them on manually according to the current light and visibility conditions. For example, fog cannot be detected by the light sensors\*. So always switch on the headlights  under these weather conditions and when driving in the dark.
- Crashes can happen when you cannot see the road ahead and when you cannot be seen by other motorists. Always turn on the headlights so that you can see ahead and so that others can see your car from the back.
- Please obey all laws when using the lighting systems described here.



### Tips

- With the switch in **AUTO** front fog lights and rear fog lights cannot be turned on in addition.
- The light sensor for headlight control is located in the rear view mirror mount. You should therefore not apply any stickers to the windshield in this area in order to prevent malfunctions or failures.
- Some exterior lighting functions can be adjusted ⇒ *page 58*.
- When you remove your key from the ignition while the vehicle's lights are turned on, a buzzer sounds as long as the driver's door is open.
- In cool or damp weather, the inside of the headlights, turn signals and tail lights can fog over due to the temperature difference between the inside and outside. They will clear shortly after switching them on. This does not affect the service life of the lighting.

- In the event of a light sensor malfunction, the driver is notified in the instrument cluster display ⇒ *page 35*.

### Adjusting exterior lighting

The functions are set in the MMI.

- ▶ Select:  function button > **Systems\*** control button > **Exterior lighting**. Or
- ▶ Select:  function button > **Car systems\*** control button > **Vehicle settings** > **Exterior lighting**.

### Coming home (Lights when leaving car), Leaving home (Lights when unlocking car)

The coming home function illuminates the area outside the vehicle when you turn the ignition off and open the driver's door. Depending on vehicle equipment, the function can be switched on and off or the length of time the lights remain on\* can be adjusted.

The leaving home illuminates the area outside the vehicle when you unlock the vehicle. This function can be switched on and off.

The Coming home and Leaving home functions only operate when it is dark and the light switch is in the **AUTO** position.

### Daytime running lights

**USA models:** The daytime running lights can be turned on or off using this function.

**Canada models:** The function cannot be turned off. It is activated automatically each time the ignition is turned on. This menu item is shown "greyed out".

### Front fog lights



Fig. 54 Instrument panel: light switch

The light switch must not be overturned past the stops in **either** direction.

### Switching on the front fog lights $\text{☞}$

- ▶ Turn the light switch to  $\text{☞}$  or to  $\text{☞D}$ .
- ▶ Pull the light switch to the *first* stop ①.

When the front fog lights are on, the symbol  $\text{☞}$  next to the light switch will illuminate.

#### **i** Tips

With the switch in **AUTO** front fog lights and rear fog lights cannot be turned on in addition.

### Rear fog lights



Fig. 55 Instrument panel: light switch

The light switch must not be overturned past the stops in **either** direction.

- ▶ Turn the light switch to  $\text{☞}$  or to  $\text{☞D}$ .
- ▶ Pull the light switch to the *second* stop ②.

When the rear fog lights are on, both the  $\text{☞}$  and  $\text{☞}$  symbols next to the light switch will illuminate.

#### **!** Note

The rear fog lights can distract drivers behind you, so, they should be turned on **only** in conditions of very poor visibility. Always observe local regulations when using the rear fog lights.

#### **i** Tips

With the switch in **AUTO** front fog lights and rear fog lights cannot be turned on in addition.

### Adaptive light

Applies to vehicles: with adaptive light

*When driving around bends, the relevant area of the road is better illuminated.*

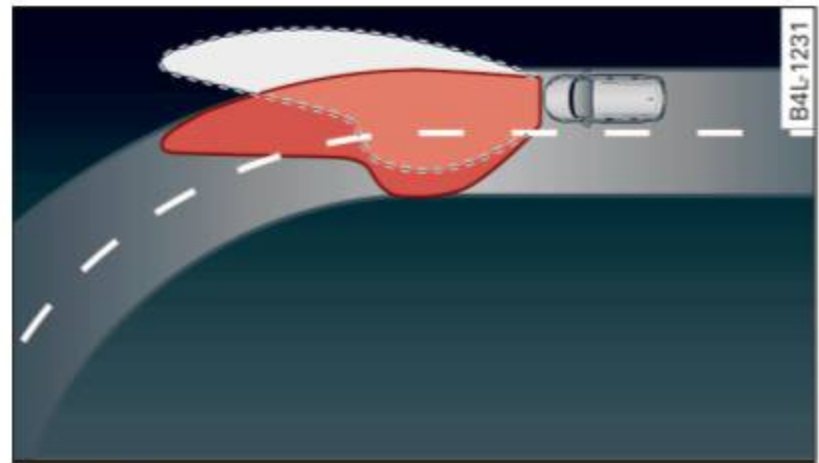

Fig. 56 Adaptive light when driving

### Switching on adaptive light

- ▶ Turn the light switch to **AUTO** ⇒ page 57, fig. 53.

The adaptive light is a dynamic cornering light. When the light is on, it follows the curve of the road. It is dependant upon the vehicle speed and the angle of the steering wheel. The curve is then better illuminated. The system works when the vehicle is moving from 6 mph (10 km/h) to 68 mph (110 km/h).

The cornering light will switch on automatically at a specific steering wheel angle. It works up to an approximate speed of 44 mph (70 km/h).

At approximately 72 mph (115 km/h) the expressway light switches on, which better distributes the light and increases the light cone range. The expressway light switches off at approximately 62 mph (100 km/h).

### Perimeter lighting in the mirror housing

Applies to vehicles: with light package

*LEDs in the exterior mirror housing illuminate the ground during entry.*

This function ensures that **when unlocking**, the vehicle periphery is illuminated in the dark. LEDs in the exterior mirror housing are switched on. The function cannot be turned off separately.



### Emergency flasher

The emergency flasher makes other motorists aware that you or your vehicle are in an emergency situation.



Fig. 57 Center console: emergency flasher switch

- ▶ Press the switch  ⇒ *fig. 57* to turn the emergency flashers on or off.

When the emergency flasher is on, all four turn signals blink at the same time. The turn signal indicator lights  in the instrument cluster, as well as the light in the emergency flasher switch  blink likewise.

The emergency flashers will turn on automatically if you are in an accident where the airbag has deployed.

#### Tips

You should turn on the emergency flashers when:

- you are the last vehicle standing in a traffic jam so that any other vehicles coming can see you, or when
- your vehicle has broken down or you are in an emergency situation, or when
- your vehicle is being towed by a tow truck or if you are towing another vehicle behind you.

### Turn signal and high beam lever

The lever on the left side of the steering column is used to operate the turn signals and the high beam as well as the headlight flasher.

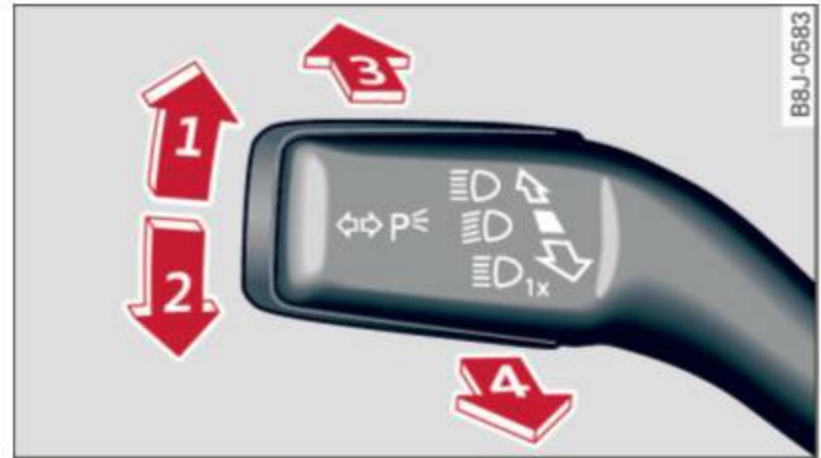

Fig. 58 Turn signal and high beam lever

The turn signal and high beam lever has the following functions:

#### Turn signals

- ▶ Lift the lever up all the way ⇒ *fig. 58* ① to use the right turn signals, or push the lever down all the way ② to use the left turn signals.

#### Auto-blink

- ▶ Move the lever (up or down) just to the point of resistance to use the turn signals for as long as you need them, for example when changing lanes.
- ▶ Move the lever (up or down) just to the point of resistance and then release it right away to make the turn signals blink *three times*. You can use this feature for example when changing lanes on highways.





#### High beam

- ▶ Push the lever forward ③ to switch on the high beam.
- ▶ Pull the lever back towards you to switch off the high beam.

#### Headlight flasher

- ▶ Pull the lever toward the steering wheel ④ to use the headlight flasher.

## Notes on these features

- The *turn signals* only work with the ignition turned on. The indicator lights  or  in the instrument cluster ⇒ *page 14* also blink.
- After you have turned a corner, the turn signal switches off automatically.
- The *high beam* works only when the headlights are on. The indicator light  in the instrument cluster illuminates when the high beams are on.
- The *headlight flasher* works only as long as you hold the lever - even if there are no lights turned on. The indicator light  in the instrument cluster illuminates when you use the headlight flasher.

### WARNING

Do not use the high beam or headlight flasher if you know that these could blind oncoming traffic.

## Interior lights

### Front interior lights

The interior lights include reading lights for both the driver and the front passenger.

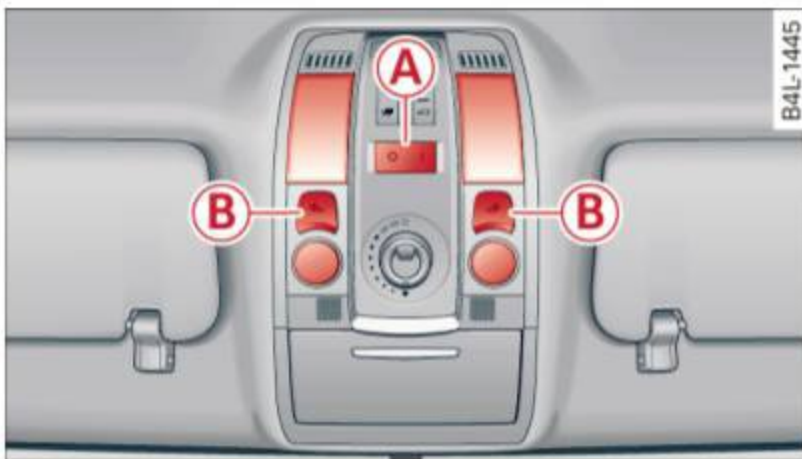

Fig. 59 Headliner: Front interior/reading lights

The rocker switch **(A)** ⇒ *fig. 59* for operating the interior lighting has the following functions:

### Door contact switch

- ▶ Place the switch **(A)** in the middle position.

### Interior light switched on

- ▶ Place the switch **(A)** in position I.

### Interior light switched off

- ▶ Place the switch **(A)** in position O.

### Reading lights

- ▶ Press one of the switches **(B)** to turn the right or left reading light on or off.

In the door contact switch position (switch **(A)** in the middle position), the interior lights turn on as soon as you unlock the vehicle or open the doors. The interior lights are also turned on when the ignition key is removed. The light goes out about 30 seconds after the doors are closed. When the vehicle is locked or when the ignition is turned on, the interior lights are turned off.

When a door is open, the interior lights are turned off after about 10 minutes to prevent draining the battery.

The brightness of the lights is controlled automatically by a dimmer when they are switched on and off.

### Rear interior lights

There are reading lights in the rear for the passengers.



Fig. 60 Headliner: Rear reading lights



Fig. 61 Headliner: Third row reading light

- ▶ Press one of the switches  to turn the right or left reading light on or off ⇒ *fig. 60*.

For vehicles with third row seating\*, the luggage compartment light can be switched on and off with the button  and used as a reading light ⇒ *fig. 61*. The rear lid has to be closed.

The lights in the luggage compartment and in the rear lid switch on and off automatically when the lid is opened and closed.



### Tips

If the rear lid remains open longer than 10 minutes, the luggage compartment lights turn off automatically to prevent the vehicle battery from discharging.

## Ambience lighting

Applies to vehicles: with ambience lighting

*The ambience lighting can be adjusted in the MMI.*

- ▶ Select:  function button > **Systems\*** control button > **Ambience lighting**. Or
- ▶ Select:  function button > **Car systems\*** control button > **Vehicle settings** > **Interior lighting**.

When the vehicle is unlocked, the standard lighting turns on automatically and dims after approx. 2 minutes, and when the ignition is turned on it switches off immediately.

### The following interior lighting is controlled:

- Front footwell
- Rear footwell
- Front door panel
- Rear door panel

## Vision

### Sun visors

*Using the sun visors makes driving safer.*

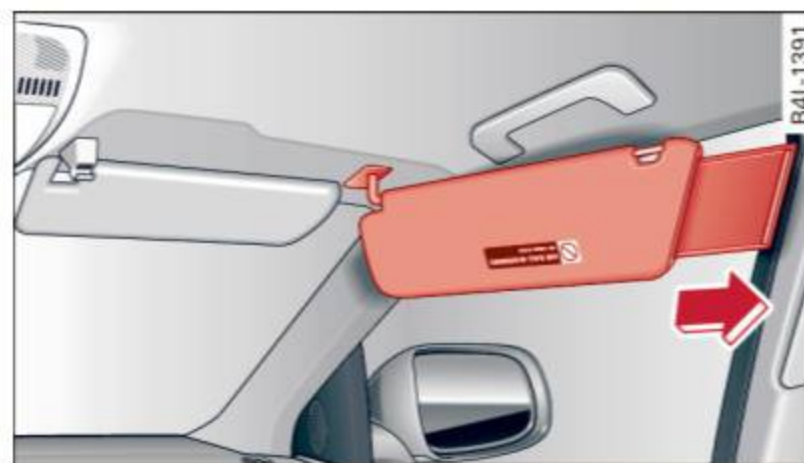

Fig. 62 Passenger side: Sun visor

### Sun visors

The forward visor of the dual sun visor can be pulled out of its bracket in the center of the vehicle and swung towards the door. The sun visor can be extended after it is swung towards the door ⇒ *fig. 62*.

### Vanity mirror

The vanity mirrors on the sun visors are covered. When the cover is raised, the mirror lighting switches on automatically. It turns off when the lid is closed or the visor is folded up again.

## Sun shade

Applies to vehicles: with sun shade

The windows in the rear doors and the rear window are each equipped with a sun shade.



Fig. 63 Sun shade pulled up on a rear window



Fig. 64 Sun shade pulled up on the rear lid window

### Sun shade (rear doors)

- ▶ Pull the shade out and hang it in the bracket on the upper door frame ⇒ *fig. 63*.

### Sun shade (rear window)

- ▶ Pull the shade out and hang it in the bracket on the rear lid frame ⇒ *fig. 64*.

## Wiper and washer system

### Switching the windshield wipers on

The windshield wiper lever controls both the windshield wipers and the washer system.

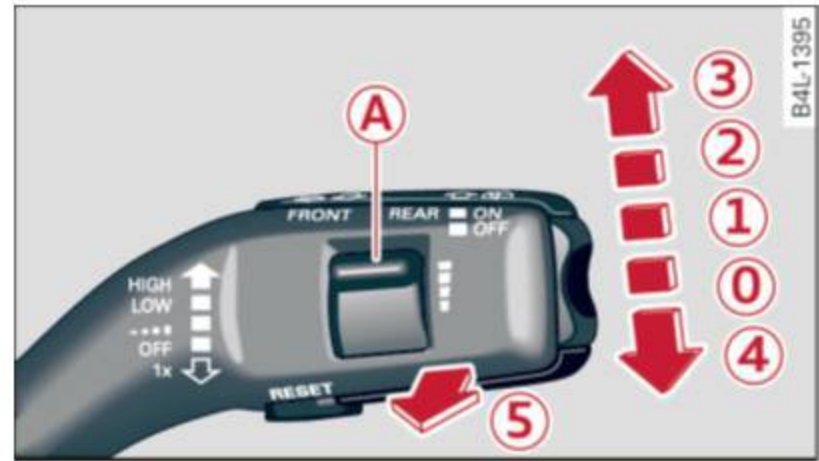

Fig. 65 Windshield wiper lever

The windshield wiper lever ⇒ *fig. 65* has the following positions:

### Activating rain sensor

- ▶ Move the lever up to position ①.
- ▶ Move switch ① up or down to adjust the sensitivity of the rain sensor.

### Low wiper speed

- ▶ Move the lever up to position ②.

### High wiper speed

- ▶ Move the lever up to position ③.

### One-touch wiper

- ▶ Move the lever to position ④, when you want to wipe the windshield *briefly*.

### Automatic wiper/washer

- ▶ Pull the lever to position ⑤ (toward the steering wheel) and hold.
- ▶ Release the lever. The washer stops and the wipers keep going for about four seconds. Depending on how long the lever is held, different numbers of wash cycles are performed.

### Turning off the wipers

- ▶ Move the lever back to position ①.

### General information

The windshield wipers and the windshield washer system operate only with the ignition on.

During a temporary stop, e.g. at a traffic signal, the set wipe speed is automatically reduced by one stage.

The windshield washer nozzles are heated at low temperatures when the ignition is on.

### Removing water droplets

About 5 seconds after the wash cycle is complete, the wiper system performs a single automatic wipe cycle to remove any water droplets that remain on the windshield while driving.

If you would like to deactivate this delayed wipe cycle while driving, you have to pull the lever to position **5** again within 10 seconds after this wipe cycle.

Water droplet removal is reactivated after the ignition is switched off and then on again.

### Winter position

To speed up de-icing of the windshield wipers, they move to the winter position when the ignition is switched off and at an outside temperature below 39 °F (4 °C). In this position, the windshield wipers are in an area on the glass which is reached by the air vents below the glass. It is also easier to remove snow and ice from the windshield wipers in this position.

The wipers leave the winter position, when the ignition is switched on, if the windshield wiper lever is operated or the active rain sensor reacts to moisture.

### Rain sensor

The rain sensor operates only in the interval wiper position. When it starts to rain, the interval wiper mode is activated automatically.

If the windshield wiper lever is in the interval wipe position with the ignition switched off,

the rain sensor is not activated until vehicle speed is above 4 mph (6 km/h).

To reduce the sensitivity of the rain sensor, the switch **A** must be moved down. To increase the sensitivity of the rain sensor, the switch must be moved up.

The higher the sensitivity setting, the sooner the windshield wipers react to moisture on the windshield. Increased sensitivity is signaled by the windshield wipers making a single pass over the windshield.

The rain sensor wiper intervals depend on the sensitivity setting as well as vehicle speed. During brief stops, wiper motion will adjust in relation to the amount of rain on the windshield.

### WARNING

- Wiper blades are crucial for safe driving! Only when they are in good condition are they able to clear the windows properly to provide uncompromised visibility. Worn or damaged wiper blades are a safety hazard ⇒ *page 66, Replacing windshield wiper blades!*
- The rain sensor is only designed to assist and support the driver. It remains entirely the driver's responsibility to monitor outside weather conditions and to manually activate the wipers as soon as rain or drizzle reduces visibility through the windshield.

### Note

- In freezing or near freezing conditions:
- Always check that the wiper blades are not frozen to the glass before you turn the wipers on. Loosen a wiper blade which is frozen in place before operating the wipers to prevent damage to the wiper blade or the wiper motor.
  - Do not use the wipers to clear a frosted window. Using the wipers as a convenient ice scraper will destroy the wiper blades.

- Prior to using a car wash, the windshield wiper system must be switched off (lever in position 0). This helps to prevent unintentional switching on and damage to the windshield wiper system.

### **i** Tips

- The windshield wipers are switched off when the ignition is turned off. Activate the windshield wipers after the ignition is switched back on by moving the windshield wiper lever to any position.
- Worn or dirty windshield wiper blades cause smearing which can affect the operation of the rain sensor. Check the condition of your windshield wiper blades regularly.
- The rain sensor is part of the interval wiping system. Turning off the ignition will also deactivate the rain sensor. To reactivate the sensor, switch off the interval wiping function, then switch it back on again.
- Make sure the washer fluid reservoir in the engine compartment is topped off before going on a long trip. Look up ⇒ *page 279* for checking and filling the washer container.

## Rear window wiper

The wiper lever is also used to operate the rear window wiper and the automatic wiper/washer function.



**Fig. 66** Wiper lever: activating the rear window wiper and washer

The rear window wiper and the automatic wiper/washer functions are activated as follows:

### Intermittent wiping

- ▶ Push the wiper lever forward to the *first* position ⑥ ⇒ *fig. 66*. The rear window wiper will wipe the window approx. every four seconds.

### Automatic wiper/washer function

- ▶ Push the wiper lever forward to the *second* stop, position ⑦, and hold it there for as long as you want the rear wiper/washer to operate.
- ▶ Release the lever again. the wiper will keep running for approx. four seconds.

### Switching intermittent wiper action off

- ▶ Pull the lever all the way back to the original position.

As soon as the reverse gear is engaged and the front wipers are turned on and operating at the same time, the rear wiper also turns on automatically.

### **!** WARNING

Wiper blades are crucial for safe driving! Only in good condition are they able to clear the windows properly to provide unrestricted visibility. Worn or frayed wiper blades are a safety hazard! ⇒ *page 66, Replacing windshield wiper blades*

### **!** Note

- In freezing or near freezing conditions:
- Always check that the wiper blades are not frozen to the glass before you turn the wiper on. Loosen a wiper blade which is frozen in place before operating the wiper to prevent damage to the wiper blade or the wiper motor.
  - Do not use the wiper to clear a frosted window. Using the wipers as a convenient ice scraper will destroy the wiper blades.

### Headlight washer system

Applies to vehicles: with headlight washer system

*The headlight washer system cleans the headlights.*

- ▶ Operate the windshield wiper/washer system ⇒ page 63, fig. 65 ⑤ with the headlights turned on by holding the lever for longer than one second.

The washer jets extend forward out of the front bumper driven by water pressure to spray the front headlights with water.

You should inspect the headlights regularly (for example when refueling) and clean off any solid dirt or insects from the lenses.

To ensure the system works properly in winter, keep the washer jets free of snow and remove any ice using a de-icing spray.

### Service position

*The wiper blades can only be changed in the service position.*

- ▶ If the wiper blades are not frozen to the windshield, bring the windshield wiper lever to the basic position ① ⇒ page 63, fig. 65.
- ▶ Select: **CAR** function button > **Systems\*** control button > **Windshield wipers** > **Service position**. Or
- ▶ Select: **CAR** function button > **Car systems\*** control button > **Servicing & checks** > **Wiper service position**.

– **On** - changing the windshield wiper blades can only be done if you bring the wiper arms to the service position. You will also avoid paint damage to the hood when working on the wipers in this position.

– **Off** - the windshield wipers are moved to their initial position again.

### ! Note

Never maneuver your vehicle with the front windshield wiper arms raised since they will automatically be moved back to

their basic position above a speed of 3 mph (6 km/h) and can scratch the hood.

### i Tips

- You can also use the service position, for example, if you want to protect the windshield from icing by using a cover.
- The service position automatically switches to **Off** when you operate the windshield wiper lever, or speed exceeds 3 mph (6 km/h).

### Replacing windshield wiper blades

*Wiper blades in good condition help keep the windshield clear.*

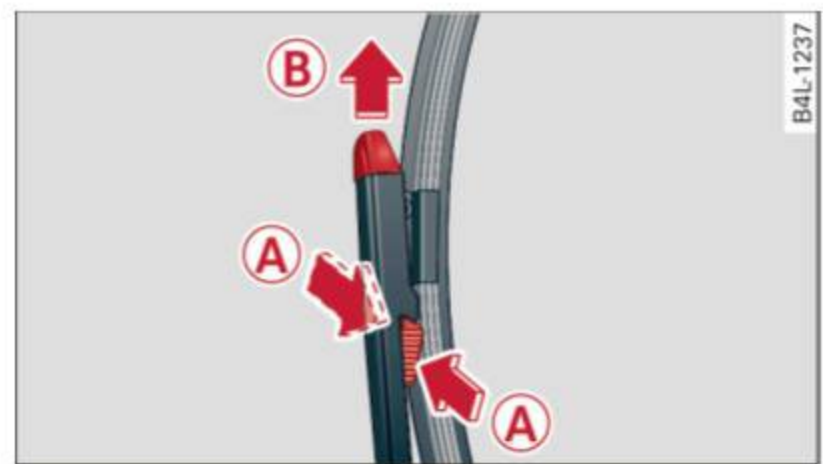

Fig. 67 Removing the wiper blades

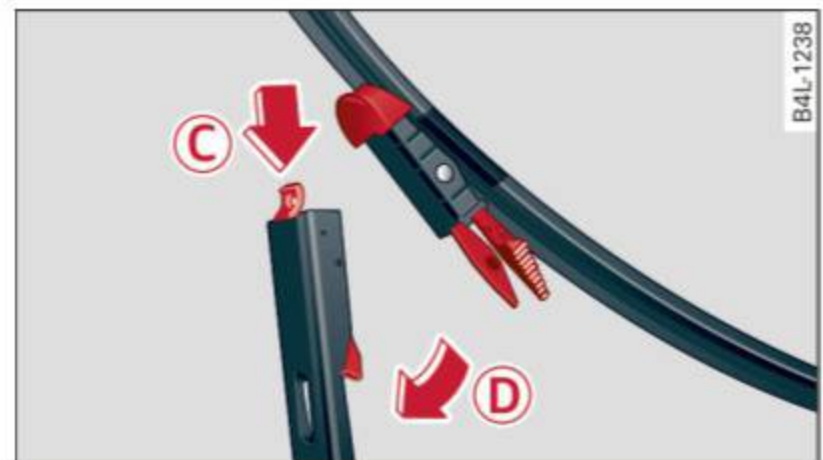

Fig. 68 Installing wiper blades

### Removing a wiper blade

- ▶ Bring the windshield wipers to the service position ⇒ page 66.
- ▶ Lift the wiper arm away from the windshield.
- ▶ Squeeze the plastic bracket on the windshield wiper arm together on both sides ① ⇒ fig. 67.
- ▶ Turn the wiper blade away from the wiper arm.

- ▶ Lift the wiper blade off in the direction of the arrow **(B)**.

### Installing wiper blade

- ▶ Place the new wiper blade in the retainer on the wiper arm **(C)** ⇒ *fig. 68*.
- ▶ Swing the wiper blade in the direction of the arrow **(D)** against the wiper arm.
- ▶ Squeeze the corrugation on the wiper until you hear the bracket click in the wiper arm.
- ▶ Place the wiper arm back against the windshield.

Clean your wiper blades regularly with a windshield washer solution to prevent streaking. If the blades are very dirty, for example with insects, carefully clean the blades with a sponge or a soft brush.

If the wiper blades begin to streak the windshield, this could be caused by residue left on the windshield by automatic car washes.

Fill the windshield washer container with a special solution available at your authorized Audi dealer to remove the residue.

#### **!** WARNING

Be sure to inspect the condition of your wiper blades regularly. See your authorized Audi dealer for replacement blades.

#### **!** Note

- The windshield wiper blades must only be replaced when in the service position ⇒ *page 66*! Otherwise, you risk damaging the paint on the hood or the windshield wiper motor.
- To help prevent damage to the wiper system, always loosen blades which are frozen to the windshield before operating wipers.
- To help prevent damage to wiper blades, do not use gasoline, kerosene, paint thinner, or other solvents on or near the wiper blades.
- To help prevent damage to the wiper arms or other components, do not attempt to move the wipers by hand.

#### **i** Tips

Commercial hot waxes applied by automatic car washes affect the cleanability of the windshield.

### Changing the rear wiper blade

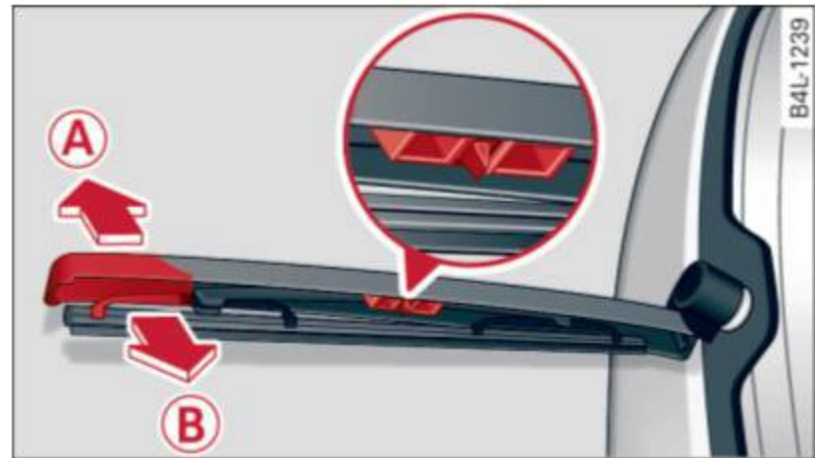

Fig. 69 Rear window wiper Detaching the rear wiper blade

### Removing the wiper blade

- ▶ Fold the windshield wiper arm away from the glass.
- ▶ Grasp the upper end of the wiper arm with one hand and the metal clamp on the wiper blade with the other ⇒ *fig. 69*.
- ▶ Hold the wiper arm in the direction of the arrow **(A)** and pull the wiper blade out of the holder only in the direction of the arrow **(B)**.

### Attaching the wiper blade

- ▶ Adjust the wiper blade in the holder.
- ▶ Hold the upper end of the wiper arm with one hand.
- ▶ Press the wiper blade into the holder with your other hand.
- ▶ Fold the wiper arm back onto the windshield.

#### **!** WARNING

- To avoid streaks, you should clean the windshield wiper blades regularly with window cleaner. For heavy soiling, for example, insects, the wiper blades can also be cleaned with a sponge or a cloth.
- For safety reasons, the windshield wiper blades should be replaced once or twice a year.

## Mirrors

### Adjusting the exterior mirrors

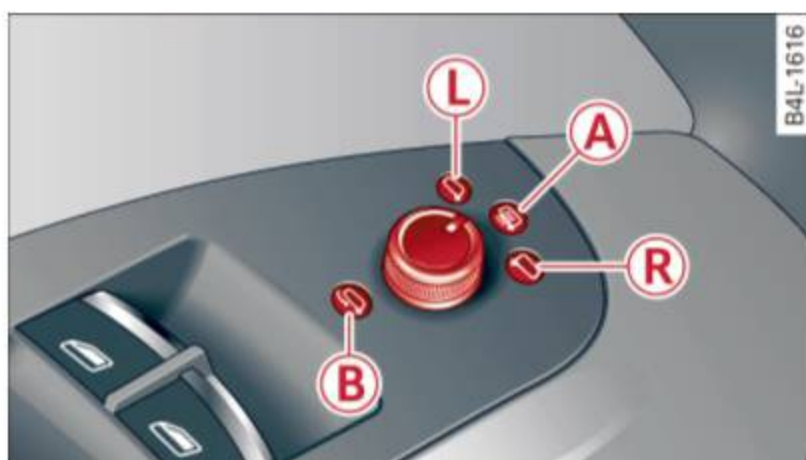

Fig. 70 Forward section of driver's armrest: power mirror controls

### Adjusting exterior mirrors

- ▶ Rotate the knob to the **L** position (driver's exterior mirror) or to the **R** position (passenger's exterior mirror) ⇒ *fig. 70*.
- ▶ Rotate the knob and the mirror so that you have a clear view to the rear.

### Heated mirrors

- ▶ Rotate the knob to position **A**.

### Folding both exterior mirrors flat\*

- ▶ Rotate the knob to position **B**.

Depending on the outside temperature, the mirror surfaces are heated until the ignition is switched off - even if the knob is no longer in position **A**.

You are well-advised to fold the exterior mirrors in when maneuvering in tight spaces or when leaving the car parked close to other vehicles.

### Memory setting for the exterior mirrors\*

When the seat position is saved in the memory, the position of the exterior mirrors is saved at the same time ⇒ *page 73*.

If the position of the passenger mirror is changed when the vehicle is in reverse gear and the switch is in the **R** position, this new tilted position will be automatically saved to the remote key when the vehicle is taken out of reverse gear. To save, the rotary knob for mirror adjustment must be in the **R** position,

the selector lever must be in the P position and the ignition must be off. This will now become the stored setting when the vehicle is put in reverse gear again.

### Tilting the passenger's side exterior mirror (only with seat memory)

When you move the selector lever into **R** (Reverse), the mirror on the front passenger's door (knob turned to **R** ⇒ *fig. 70*) will tilt slightly downward. This makes it easier for you to see the curb when you are backing into a parking space.

The mirror returns to its initial position as soon as reverse gear is disengaged and vehicle speed is above about 9 mph (15 km/h). The mirror also returns to its initial position if the switch is moved to the driver's exterior mirror **L** or the ignition is switched off.

### ! Note

- Curved (i.e. convex) mirror surfaces increase your field of view. Remember that vehicles or other objects will appear smaller and farther away than when seen in a flat mirror. If you use this mirror to estimate distances of following vehicles when changing lanes, you could estimate incorrectly and cause an accident.
- If the mirror housing is moved unintentionally (for example, while parking your vehicle), then you must first fold the mirror electrically. Do not readjust the mirror housing manually. You could damage the motor which controls the mirror.
- If you wash the vehicle in an automatic car wash, you must fold the exterior mirrors in to reduce the risk of damage to the mirrors. Never fold power folding exterior mirrors\* by hand. Only fold them in and out using the power controls.

### i Tips

If there should be a malfunction in the electrical system, you can still adjust the exterior mirrors by pressing the edge of the mirror.

## Dimming the mirrors

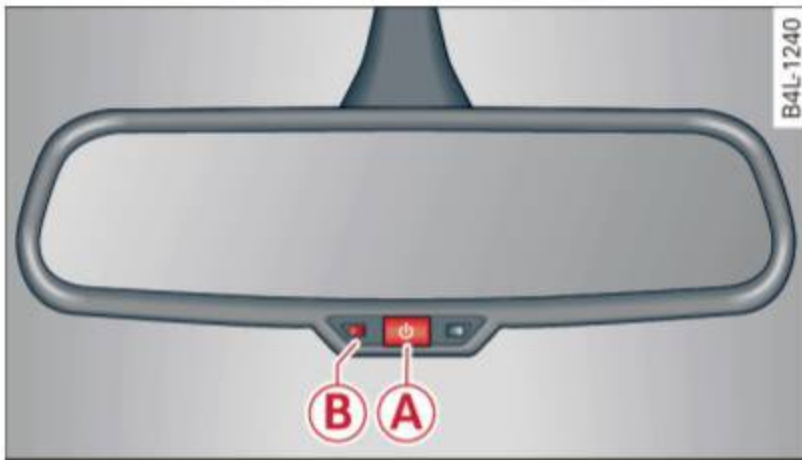

Fig. 71 Automatic dimming rearview mirror\*

### Manual anti-glare adjustment

- ▶ Move the small lever (located on the bottom edge of the mirror) to the rear.

### Automatically dimming mirrors\*

- ▶ To dim the rearview mirror and both exterior mirrors\*, press the **A** button. The diode **B** turns on. The rearview and exterior mirrors\* dim automatically when light shines on them, for example from headlights on a vehicle to the rear.

### **!** WARNING

Electrolyte fluid can leak from automatic dimming mirrors if the glass is broken. Electrolyte fluid can irritate skin, eyes and respiratory system.

- Repeated or prolonged exposure to electrolyte can cause irritation to the respiratory system, especially among people with asthma or other respiratory conditions. Get fresh air immediately by leaving the vehicle or, if that is not possible, open windows and doors all the way.
- If electrolyte gets into the eyes, flush them thoroughly with large amounts of clean water for at least 15 minutes; medical attention is recommended.
- If electrolyte contacts skin, flush affected area with clean water for at least 15 minutes and then wash affected area with soap and water; medical attention is recommended. Thoroughly wash affected clothing and shoes before reuse.

- If swallowed and person is conscious, rinse mouth with water for at least 15 minutes. Do not induce vomiting unless instructed to do so by medical professional. Get medical attention immediately.

### **!** Note

Liquid electrolyte leaking from broken mirror glass will damage any plastic surfaces it comes in contact with. Clean up spilled electrolyte immediately with clean water and a sponge.

### **i** Tips

- Switching off the dimming function of the inside rear view mirror also deactivates the automatic dimming function of the exterior mirrors\*.
- The automatic dimming mirrors do not dim when the interior lighting is turned on or the reverse gear is selected.
- Automatic dimming for the mirror only operates properly if the sun shade\* for the rear window is not in use or the light striking the inside mirror is not hindered by other objects.

## Digital compass

### Activating or deactivating the compass

Applies to vehicles: with digital compass

*The direction is displayed on the interior rear view mirror.*



Fig. 72 Inside rear view mirror: digital compass activated

- ▶ To activate or deactivate, hold the **A** button down until the red display appears or disappears.

The digital compass only works with the ignition turned on. The directions are displayed as initials: **N** (North), **NE** (Northeast), **E** (East), **SE** (Southeast), **S** (South), **SW** (Southwest), **W** (West), **NW** (Northwest).

### **i** Tips

To avoid inaccurate directions, do not allow any remote controls, electrical systems, or metal parts close to the mirror.

### Setting the magnetic deflection zone

Applies to vehicles: with digital compass

*The correct magnetic deflection zone must be set in order to display the directions correctly.*

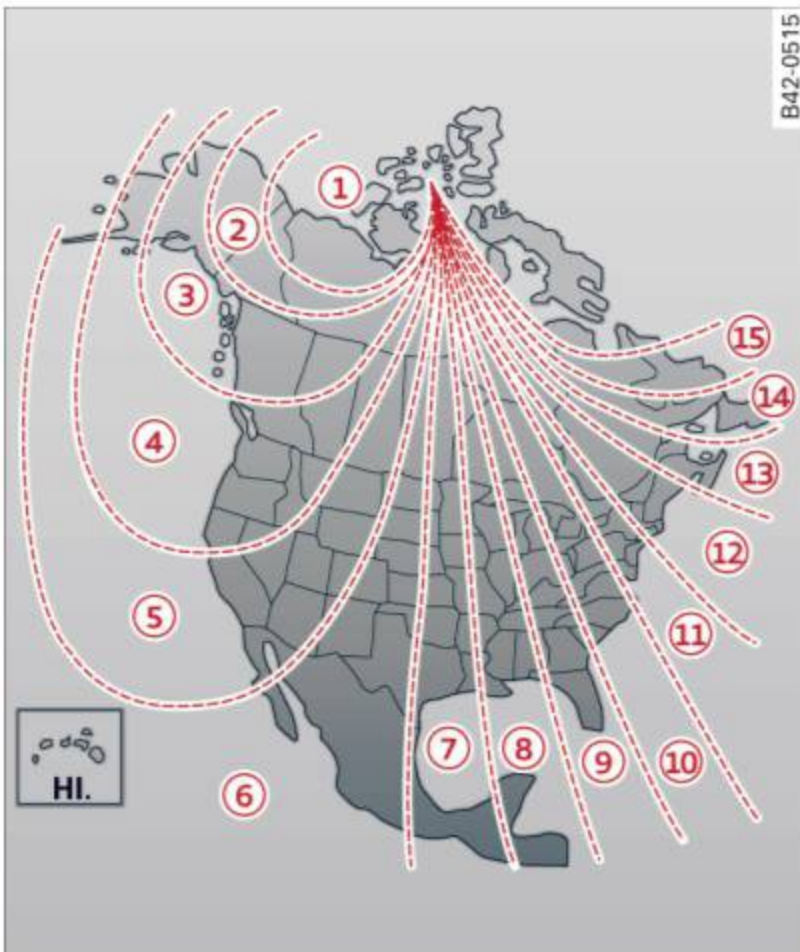

**Fig. 73** North America: magnetic deflection zone boundaries

- ▶ Hold the **(A)** ⇒ page 69, fig. 72 button down until the number of the set magnetic deflection zone appears on the interior rear view mirror.
- ▶ Adjust the magnetic deflection zone by repeatedly pressing on the **(A)** button. The set mode automatically deactivates after a few seconds.

### Calibrating the compass

Applies to vehicles: with digital compass

*The compass has to be recalibrated if the display is wrong or inaccurate.*

- ▶ Hold the **(A)** button down until the letter **C** is displayed on the interior rear view mirror.
- ▶ Drive in a circle at a speed of about 5 mph (10 km/h) until a direction is shown on the interior rear view mirror.

### **!** WARNING

The digital compass is to be used as a directional aid only. Even though you may want to look at it while you are driving, you must still pay attention to traffic, road and weather conditions as well as other possible hazards.

## Seats and storage

### General recommendations

#### Why is your seat adjustment so important?

*The safety belts and the airbag system can only provide maximum protection if the front seats are correctly adjusted.*

There are various ways of adjusting the front seats to provide safe and comfortable support for the driver and the front passenger. Adjust your seat properly so that:

- you can easily and quickly reach all the switches and controls in the instrument panel
- your body is properly supported thus reducing physical stress and fatigue
- the safety belts and airbag system can offer maximum protection ⇒ *page 184*.

In the following sections, you will see exactly how you can best adjust your seats.

There are special regulations and instructions for installing a child safety seat on the front passenger's seat. Always follow the information regarding child safety provided in ⇒ *page 205, Child Safety*.

#### WARNING

Incorrect seating position of the driver and all other passengers can result in serious personal injury.

- Always keep your feet on the floor when the vehicle is in motion — never put your feet on top of the instrument panel, out of the window or on top of the seat cushion. This applies especially to the passengers. If your seating position is incorrect, you increase the risk of injury in the case of sudden braking or an accident. If the airbag inflates and the seating position is incorrect, this could result in personal injury or even death.
- It is important for both the driver and front passenger to keep a distance of at

least 10 inches (25 cm) between themselves and the steering wheel and/or instrument panel. If you're sitting any closer than this, the airbag system cannot protect you properly. In addition, the front seats and head restraints must be adjusted to your body height so that they can give you maximum protection.

- Always try to keep as much distance as possible between yourself and the steering wheel or instrument panel.
- Do not adjust the driver's or front passenger's seat while the vehicle is moving. Your seat may move unexpectedly, causing sudden loss of vehicle control and personal injury. If you adjust your seat while the vehicle is moving, you are out of position.

#### Driver's seat

*The correct seat position is important for safe and relaxed driving.*

We recommend that you adjust the driver's seat in the following manner:

- ▶ Adjust the seat in fore and aft direction so that you can easily push the pedals to the floor while keeping your knees slightly bent ⇒  in *Why is your seat adjustment so important? on page 71*.
- ▶ Adjust the seatback so that when you sit with your back against the seatback, you can still grasp the top of the steering wheel.
- ▶ Adjust the head restraint so the upper edge is as even as possible with the top of your head. If that is not possible, try to adjust the head restraint so that it is as close to this position as possible ⇒ *page 76*.

#### WARNING

Never place any objects in the driver's footwell. An object could get into the pedal area and interfere with pedal function. In case of sudden braking or an accident, you would not be able to brake or accelerate.

### Front passenger's seat

Always move the front passenger seat into the rearmost position.

To avoid contact with the airbag while it is deploying, do not sit any closer to the instrument panel than necessary and always wear the three-point safety belt provided adjusted correctly. We recommend that you adjust the passenger's seat in the following manner:

- ▶ Move the front passenger seat into the rearmost position of the fore and aft adjustment range ⇒ ⚠ in *Why is your seat adjustment so important?* on page 71.
- ▶ Bring the backrest up to an (almost) upright position. **Do not** ride with the seat reclined.
- ▶ Adjust the head restraint so the upper edge is as even as possible with the top of your head. If that is not possible, try to adjust the head restraint so that it is as close to this position as possible ⇒ page 76.
- ▶ Place your feet on the floor in front of the passenger's seat.

## Power front seat adjustment

### Seat adjustment controls

The operating logic for the switches corresponds to the construction and function of the seat.

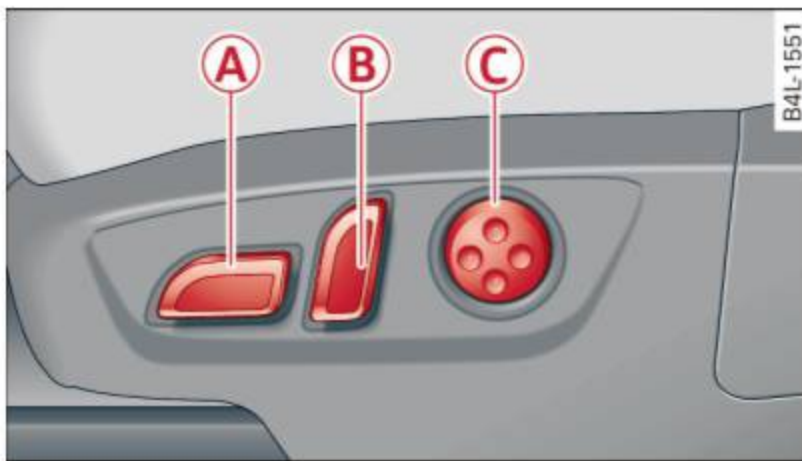

Fig. 74 Front seat: Controls for seat adjustment

The switches to adjust the seat cushion and the seatback correspond to the layout, the design and the function of the seat. The seats are adjusted by moving the switches following this logic.

### Controls

- Ⓐ Seat adjustment
- Ⓑ Seatback adjustment
- Ⓒ Lumbar support

### Adjusting the seat

Position, angle and shape of the seat can be adjusted electrically to ensure safe and comfortable seating.

Read and follow the warning notices ⇒ ⚠ before you adjust your seat.

### Fore-and-aft adjustment

- ▶ Push the switch Ⓐ forward or backward ⇒ page 72, fig. 74.

### Adjusting seat height

- ▶ Pull or push the switch Ⓐ up or down.

### Front seat cushion up / down

- ▶ Press the switch Ⓐ at the front up or down.

### Rear seat cushion up / down

- ▶ Press the switch Ⓐ at the rear up or down.

### Adjusting seatback angle

- ▶ Push the switch Ⓑ forward or backward.

### Adjusting the curvature of the lumbar support

- ▶ Push the switch plate Ⓒ forward or backward to increase or reduce the curvature.

### Adjusting the height of the lumbar support

- ▶ Push the switch plate Ⓒ up or down to position the curvature higher or lower.

### ⚠ WARNING

- Adjust the driver's seat only when the vehicle is stationary. You risk an accident otherwise.
- The power adjustment for the front seats also works with the ignition switched off or with the ignition key removed. For this reason, children should never be left

unattended in the vehicle - they could be injured!

- Exercise caution when adjusting the seat height. Unsupervised or careless seat adjustment can pinch fingers or hands causing injuries.
- While the vehicle is moving, the seatbacks of the front seats must not be inclined too far to the rear because the effectiveness of the safety belts and the airbag system is severely compromised - there is a risk of injury.
- To reduce the risk of injury in the case of sudden braking or accident, front passengers must never ride in a moving vehicle with the seatback reclined. Safety belts and the airbag system only offer maximum protection when the seatback is upright and the safety belts are properly positioned on the body. The more the seatback is reclined, the greater the risk of personal injury from an incorrect seating position and improperly positioned safety belts.

## Seat memory

### Driver's seat memory

Applies to vehicles: with seat memory

The seat adjustment settings for two drivers can be stored using the memory buttons in the driver's door.



Fig. 75 Driver's door: Seat memory

In addition to the setting for the driver's seat, the settings for the steering column\* and both exterior mirrors can be stored.

### Storing and recalling settings

Using the memory buttons 1 and 2, you can store and recall the settings for two different drivers ⇒ *fig. 75*.

The current settings are also automatically assigned to the remote control key being used when the vehicle is locked. When the vehicle is unlocked, the settings assigned to the remote control key being used are automatically recalled. This function has to be activated in the MMI ⇒ *page 74, Activating remote control key memory*.

### Turning seat memory on and off

If the **ON/OFF** switch is depressed, the seat memory is inoperative. The word **OFF** next to the **ON/OFF** switch illuminates.

All the stored settings are retained. We recommend using the **ON/OFF** switch and deactivating the seat memory if the vehicle is only going to be used *temporarily* by a driver whose settings are not going to be stored.

### Storing and recalling a seat position

Applies to vehicles: with seat memory

Before you can store or recall your seat position, the **ON/OFF** button must be engaged (down).

### Storing settings

- ▶ Adjust the driver's seat ⇒ *page 72*.
- ▶ Adjust the steering column\* ⇒ *page 103*.
- ▶ Adjust both outside mirrors ⇒ *page 68*. In the tilt-down position, the passenger mirror can be adjusted to the preferred position and saved in the seat memory.
- ▶ Press the **SET** button and hold it down. At the same time, press one of the memory buttons for at least one second.
- ▶ Release the buttons. The settings are now stored under the corresponding memory button.

### Recalling settings

- ▶ Driver's door open - press the desired memory button. ▶

- ▶ Driver's door closed - press the corresponding memory button until the stored position is reached.

Successful storage is confirmed audibly and by the light in the **SET** button illuminating.

When the vehicle is **locked**, the current settings are stored and assigned to the remote control key. But the settings stored on memory buttons 1 and 2 are not deleted. They can be recalled at any time. When the vehicle is **unlocked**, the settings assigned to the remote control key are restored.

If your vehicle is driven by other persons using your remote control key, you should save your individual seat position on one of the memory buttons. You can recall your settings again simply and conveniently by pressing the corresponding memory button. When the vehicle is locked, these settings are automatically re-assigned to the remote control key and stored.

### **WARNING**

- For safety reasons, the seat setting can only be recalled when the vehicle is stationary - otherwise you risk having an accident.
- In an emergency, the recall operation can be stopped by pressing the **ON/OFF** button or by briefly pressing any given memory button.

### **Activating remote control key memory**

Applies to vehicles: with seat memory

To assign the driver's seat settings to the remote control key when locking the vehicle, the function must be activated in the MMI.

- ▶ Select: **CAR** function button > **Systems\*** control button > **Seat adjustment** > **Driver's seat** > **Key mem. profile** > **On**. Or
- ▶ Select: **CAR** function button > **Car systems\*** control button > **Vehicle settings** > **Seats** > **Driver's seat** > **Remote control key** > **On**.

### **Tips**

If you do not want another driver's settings to be assigned to the remote control key, switch off the memory function using the MMI or the **ON/OFF** button  
⇒ page 73.

## **Rear seats**

### **General information**

*Safe transportation of passengers on the rear seats requires proper safety precautions.*

All passengers on the rear seats must be seated in compliance with the safety guidelines explained in ⇒ page 175 and ⇒ page 184. The correct seating position is critical for the safety of front *and* rear seat passengers alike ⇒ page 168.

### **WARNING**

- Occupants in the front *and* rear seats must always be properly restrained.
- Do not let anyone ride in the vehicle without the head restraints provided. Head restraints help to reduce injuries.
- Loose items inside the passenger compartment, can fly forward in a crash or sudden maneuver and injure occupants. Always store articles in the luggage compartment and use the fastening eyes, especially when the rear seatbacks have been folded down.
- Read and heed all WARNINGS  
⇒ page 168, *Proper seating positions for passengers in rear seats.*

### Adjusting seat (second row seating)

The fore-and-aft adjustment\* of the seat cushion and the seatback angle can be adjusted.

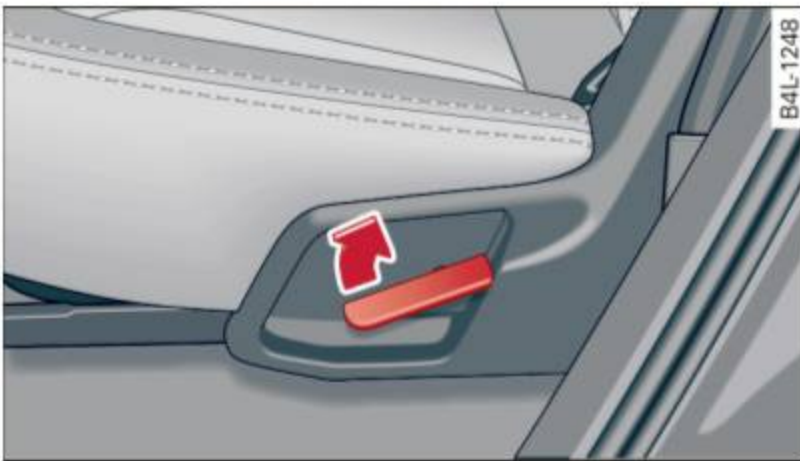

Fig. 76 Adjusting seatback angle



Fig. 77 Fore-and-aft adjustment

### Adjusting seatback angle

- ▶ Pull the lever up and push the seatback toward the rear to the desired position ⇒ fig. 76. Release the lever.
- ▶ Pull the lever up so that the seatback pivots forward. Release the lever and push the seatback to the rear to return the seatback to the normal position.

### Fore-and-aft adjustment\*

- ▶ Pull the handle up and push the seat forward or back ⇒ fig. 77.
- ▶ Release the handle and continue to push the seat until the seat latch engages.

### WARNING

- For safety reasons, the seat must only be adjusted when the vehicle is stationary - danger of accident!
- Exercise caution when adjusting the seat. Adjusting the seat without checking or

paying attention can pinch fingers or limbs - danger of injury!

### Entry assist (second row seating)

Applies to vehicles: with entry assist

The entry assist makes it easier for occupants to reach the third row seating\*.



Fig. 78 Seatback second row seating: Seatback latch

### Pushing second row of seats forward

- ▶ Lift the lever ⇒ fig. 78.
- ▶ Tilt the seatback forward.
- ▶ Push the seat forward.

### Pushing second row of seats back

- ▶ Push the seatback.
- ▶ Fold the seatback up until it latches.

To make entry to and exit from the rear of the vehicle easier, the seatbacks for the second row seating can be folded forward. At the same time, the seats can be pushed forward and to the rear.

### Folding seatback up and down (third row seating)

Applies to vehicles: with third row seating

The third row seating is suitable for persons up to 1.6 meters (5 ft 3 in) in height.

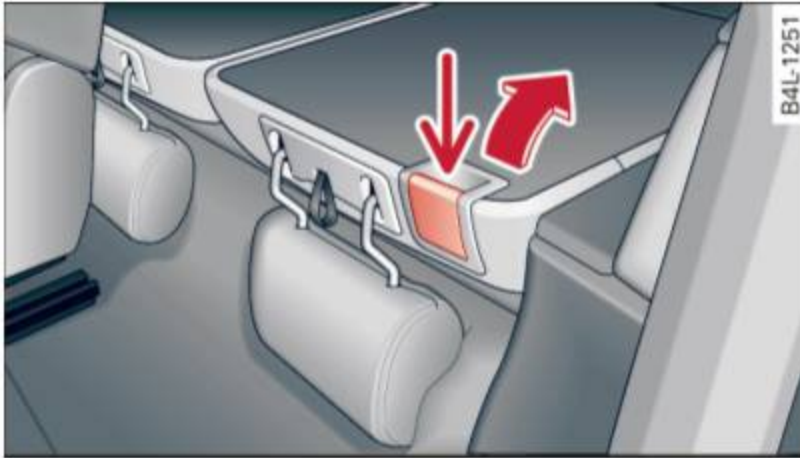

Fig. 79 Third row of seats: Folding seatback up



Fig. 80 Third row of seats: Folding seatback down

### Raising seatback

- ▶ Lift the lever -Arrow- ⇒ *fig. 79* and raise the seatback until it locks.
- ▶ Raise the head restraint until it locks.

### Folding seatback down

- ▶ Lift the lever -Arrow- ⇒ *fig. 80* and fold the seatback down completely until it locks.
- ▶ The head restraint is automatically tipped down.

#### WARNING

- Only persons up to a height of 5 feet 3 inches (1.6 m) may be carried on the seats in the third row.
- Exercise caution when folding the seatbacks up and down. Inattentiveness or carelessness when folding the seatback up and down can pinch fingers or hands.

- Always check whether the latch is fully engaged by pulling the seatback forward.

## Head restraints

### Front head restraints

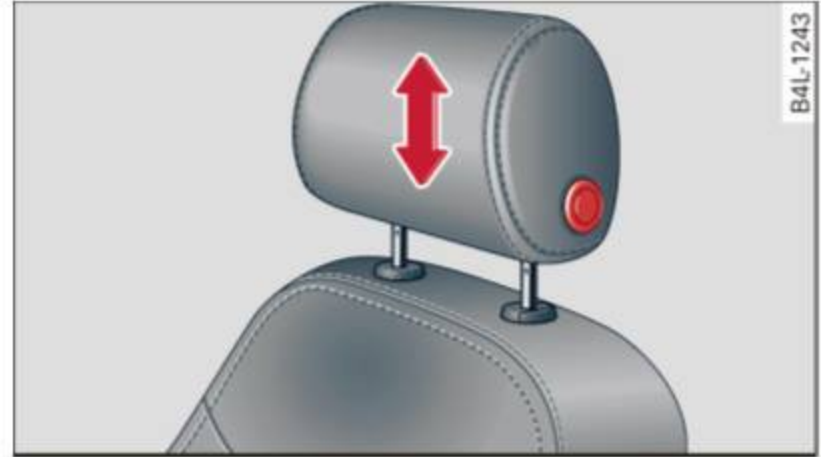

Fig. 81 Front seats head restraints: adjusting the height

The head restraints on the *front* seats can be adjusted to provide safe support to head and neck at the optimum height. When optimally adjusted, the top of the restraint should be level with the top of the head. If that is not possible, try to adjust the head restraint so that it is as close to this position as possible ⇒ *page 168, Proper adjustment of head restraints*.

- ▶ To move the head restraint up, hold it at the sides with both hands and slide it upward.
- ▶ To move the head restraint down, press the button and slide the head restraint downward ⇒ *fig. 81*.

Refer to ⇒ *page 168, Proper adjustment of head restraints* for guidelines on how to adjust the height of the front head restraints to suit the occupant's body size.

#### WARNING

- Driving without head restraints or with head restraints that are not properly adjusted increases the risk of serious or fatal neck injury dramatically.
- Read and heed all WARNINGS ⇒ *page 168*.

### **i** Tips

Correctly adjusted head restraints and safety belts are an extremely effective combination of safety features.

### Rear head restraints



Fig. 82 Rear seat: outer head restraint

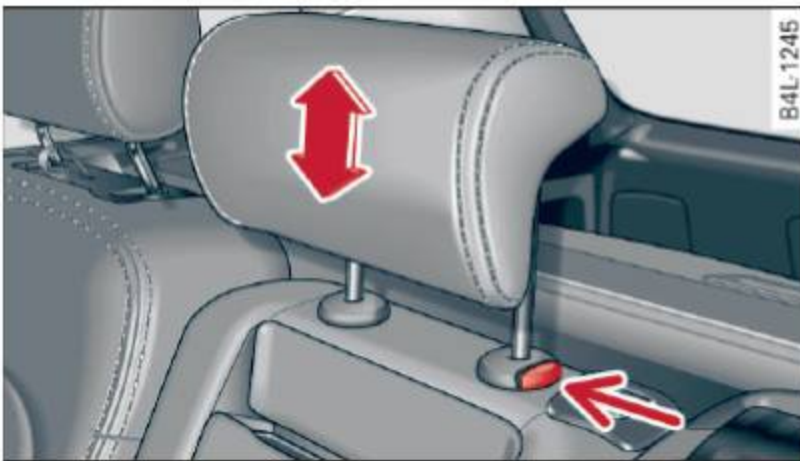



Fig. 83 Rear seat: center head restraint

If there are passengers in the rear seat, fold the head restraints up on the occupied seats or slide the center head restraint upward at least to the next notch ⇒ .

### Adjusting the outer head restraints

- ▶ To fold the head restraint out, pull on the tab ⇒ *fig. 82*.
- ▶ To fold the head restraint up, tilt it upward until you feel it click into place.

### Adjusting the center head restraint

- ▶ To move the head restraint up, hold it at the sides with both hands and slide it upward until you feel it click into place ⇒ *fig. 83*.
- ▶ To move the head restraint down, press the button -arrow- and slide the head restraint downward.

### Removing the center head restraint

- ▶ Move the head restraint upward as far as it can go.
- ▶ Press the button -arrow- and pull the head restraint out of the backrest ⇒ .

### Installing the center head restraint

- ▶ Slide the posts on the head restraint down into the guides until you feel the posts click into place.
- ▶ Press the button -arrow- and slide the head restraint all the way down. You should not be able to pull the head restraint out of the backrest.

### WARNING

- Only remove the rear seat head restraint when necessary in order to install a child seat. Install the head restraint again immediately once the child seat is removed. Driving without head restraints or with head restraints that are not properly adjusted increases the risk of serious or fatal neck injury dramatically.
- The head restraints for the outer seats in the second row must be folded up when persons are being carried in the third row seating\* - danger of injury!
- Read and heed all WARNINGS  
⇒ *page 168*

### Armrest

The armrest contains a storage compartment and two cup holders.



Fig. 84 Armrest between driver's and passenger's seat

- ▶ Push on the release lever ⇒ *fig. 84* to open the storage compartment. ▶

A maximum of two beverages can be accommodated in the armrest. The second cup holder is located under a cover.

### **WARNING**

Spilled hot liquid can cause an accident and personal injury.

- Never carry any beverage containers with hot liquids, such as hot coffee or hot tea, in the vehicle while it is moving. In case of an accident, sudden braking or other vehicle movement, hot liquid could spill, causing scalding burns. Spilled hot liquid can also cause an accident and personal injury.
- Use only soft cups in the cupholder. Hard cups and glasses can cause injury in an accident.

### **Note**

Only drink containers with lids should be carried in the cupholder. Liquid could spill out and damage your vehicle's electronic equipment or stain the upholstery, etc.

## Long center console

Applies to vehicles: with long center console

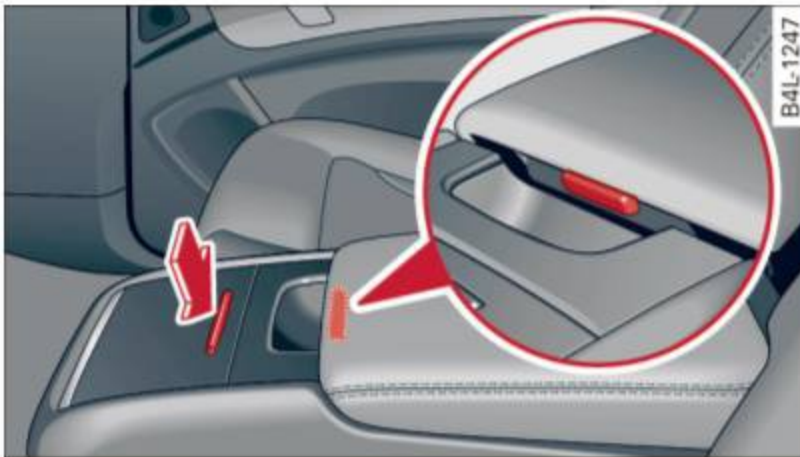

Fig. 85 Long rear center console

There are two cupholders and a storage bin in the *long* rear center console. The armrest is also height adjustable.

### Beverage holder

- ▶ Tap the cover ⇒ *fig. 85 -Arrow-* for it to open automatically.
- ▶ Push the cover down to close the bin.

### Storage compartment

- ▶ Lift the cover by the front to open the compartment.
- ▶ Push the cover down to close the bin.

### Adjusting the armrest

- ▶ Press the release button. The armrest moves up automatically.
- ▶ Release the button when the desired height is reached.
- ▶ Press the release button again and at the same time push the armrest down to lower it.

### **WARNING**

Spilled hot liquid can cause an accident and personal injury.

- Never carry any beverage containers with hot liquids, such as hot coffee or hot tea, in the vehicle while it is moving. In case of an accident, sudden braking or other vehicle movement, hot liquid could spill, causing scalding burns. Spilled hot liquid can also cause an accident and personal injury.
- Use only soft cups in the cupholder. Hard cups and glasses can cause injury in an accident.

### **Note**

Only drink containers with lids should be carried in the cupholder. Liquid could spill out and damage your vehicle's electronic equipment or stain the upholstery, etc.

## Luggage compartment

### Expanding luggage compartment

To expand the luggage compartment, the seatbacks can be folded forward separately or together.

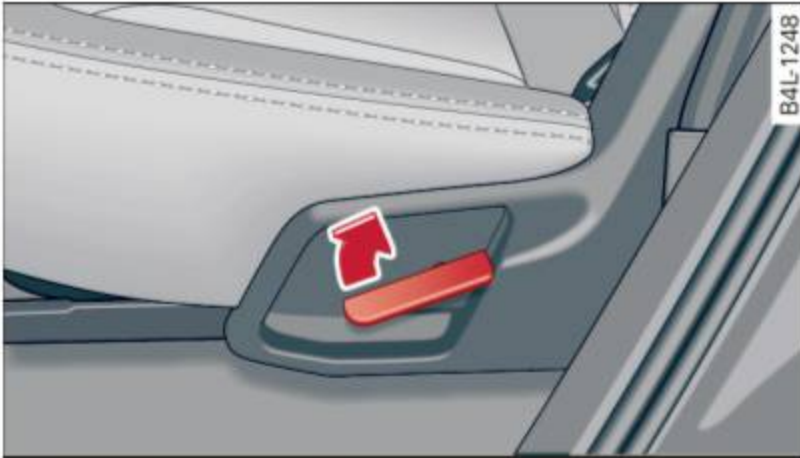

Fig. 86 Release lever for outer seatback

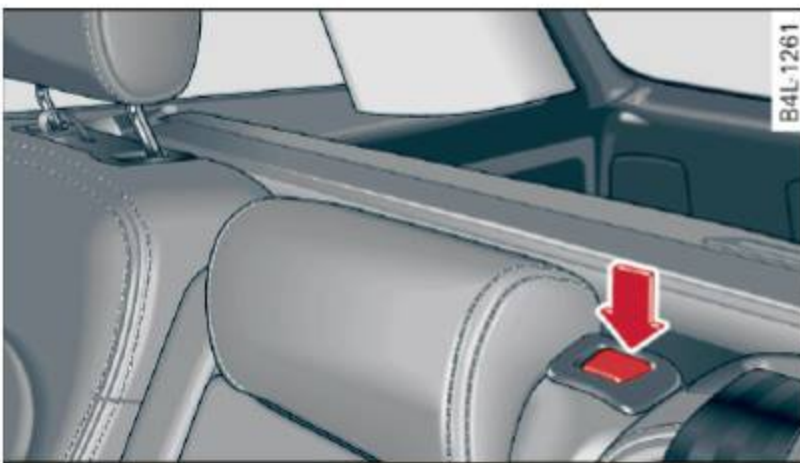

Fig. 87 Release lever for center seatback

### Folding the seatback forward

- ▶ Pull the lever up ⇒ *fig. 86*. The seatback pivots forward.
- ▶ Allow the seatback to latch in the lowermost position.

### Raising the seatback

- ▶ Pull the lever up ⇒ *fig. 86* and raise the seatback until it is securely latched ⇒ ⚠.

### Folding center seatback down

- ▶ Press the release button ⇒ *fig. 87*. The red mark on the release lever is visible.
- ▶ Tilt the seatback forward.

### Raising center seatback

- ▶ Raise the seatback until it is securely latched ⇒ ⚠. It is securely latched when the red mark on the release button is no longer visible.

The center seatback can be folded forward separately. Using this loading option, long objects (e.g. skis) can be carried in the interior.

### ⚠ WARNING

- The backrest must always be securely latched so that the safety belt of the center seating position can work properly to help protect the occupant.
- The backrest must be securely latched in position so that no items contained in the luggage compartment can slide forward upon sudden braking.
- Always check whether the latch is fully engaged by pulling the seatback forward.
- On vehicles with third row seating\*, the center seatback must be in the upright position and securely latched when persons are being carried in the third row seats - danger injury!
- Never allow safety belts to become damaged by being caught in door or seat hardware.
- Torn or frayed safety belts can tear and damaged belt hardware can break in a crash. Inspect the belts periodically. Belts showing damage to webbing, bindings, buckles, or retractors must be replaced.

### ⚠ WARNING

Always read and heed WARNINGS ⇒ ⚠ in *Loading the luggage compartment on page 171*.

### ! Note

- When folding the backrest back into place, make sure the safety belt does not get caught, because it can be damaged. A damaged belt can fail to provide safe restraint.
- The heating wires in the rear window can be damaged by abrasive objects on the parcel shelf.

### Tie-down rings

There are four tie-down rings in the luggage compartment for securing luggage items.

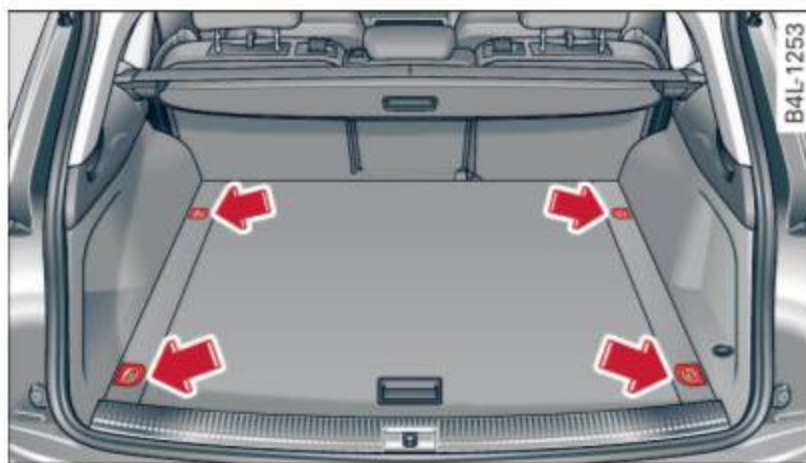

Fig. 88 Location of the tie-down rings in the luggage compartment

- ▶ Secure the cargo to the tie-down rings ⇒ *fig. 88*.
- ▶ Observe the safety notes ⇒ *page 172*.

In a collision, the laws of physics mean that even smaller items that are loose in the vehicle will turn into heavy missiles that can cause serious injury. Items in the vehicle pick up kinetic energy which varies with the vehicle and the weight of the item. Vehicle speed is the most significant factor.

For example, in a frontal collision at a speed of 30 mph (48 km/h), the forces acting on a 10-lb (5 kg) object are about 20 times the normal weight of the item. This means that the weight of the item would suddenly be the equivalent of about 200 lbs (90 kg). One can easily imagine the injuries that an item of that weight flying freely through the passenger compartment can cause in a collision at a speed considered relatively low.

#### WARNING

Weak, damaged or improper straps used to secure items to tie-downs can fail during hard braking or in a collision and cause serious personal injury.

- Always use suitable retaining straps and properly secure items to the tie-downs in the luggage compartment to help prevent items from shifting or flying forward.

- When the rear seat backrest is folded down, always use suitable retaining straps and properly secure items to the tie-downs in the luggage compartment to help prevent items from flying forward into the passenger compartment.
- Never attach a child safety seat tether strap to a tie-down.

### Cargo net

Applies to vehicles: with cargo net

The cargo net prevents light objects from sliding around in the luggage compartment.



Fig. 89 Luggage compartment: cargo net

- ▶ Next, hang the *front* hooks in the fastening eyelets.
- ▶ Then, hang the *rear* hooks in the fastening eyelets.

#### WARNING

For strength-related reasons, the mounting hooks can only be used to secure objects weighing up to 10 lb. (5 kg). Heavier objects will not be adequately secured – there is a risk of injury.

## Retractable luggage compartment cover

The luggage compartment cover keeps luggage or other objects out of view.

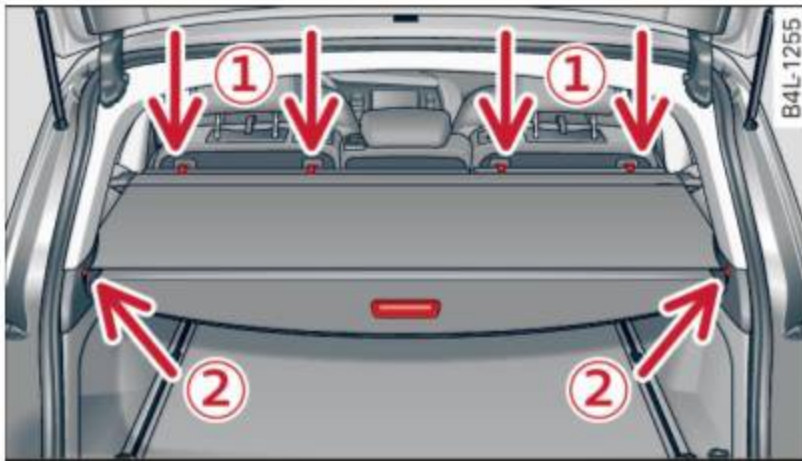

Fig. 90 Luggage compartment: compartment cover closed

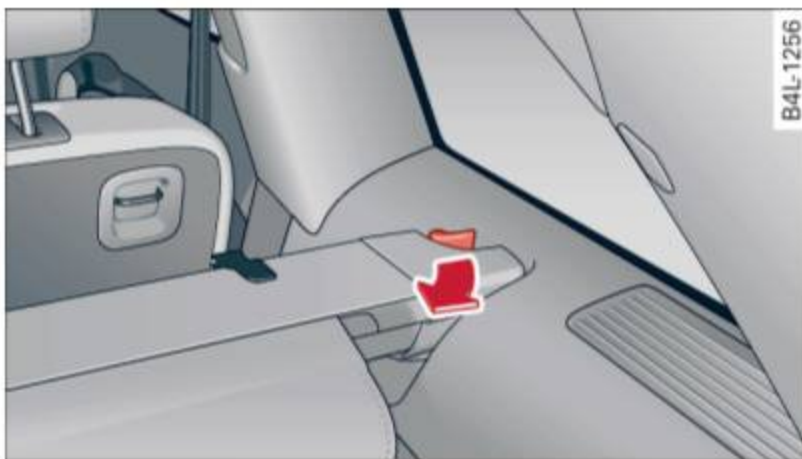

Fig. 91 Section from the front part of the luggage compartment, right side: release button for removing the luggage compartment trim panel

### Extending front luggage compartment cover

- ▶ Pull the rolled-up cover evenly towards the front of the vehicle.
- ▶ Hang the ends of the cover in the attaching eyes on the left and right of the seatback ⇒ fig. 90 ①.

### Extending rear luggage compartment cover

- ▶ Pull the rolled-up cover evenly towards the rear of the vehicle using the handle.
- ▶ Hook the ends of the rod in the openings in the left and right side trim panels ②.

### Rolling up front luggage compartment cover

- ▶ Pull the ends of the cover out of the attaching eyes in the seatback.
- ▶ Allow the cover to roll up slowly.

### Rolling up rear luggage compartment cover

- ▶ Pull the rod out of the openings in the side trim panels.
- ▶ Allow the cover to roll up slowly.

### Removing the luggage compartment cover

- ▶ Pull the lever in the direction of the arrow ⇒ fig. 91 and at the same time lift the cover up and out.

### Installing the luggage compartment cover

- ▶ Lay the cover in the left retainer in the side trim and then press it into the right retainer until it latches.

### ! WARNING

Whenever driving, never place any hard or heavy objects on the luggage compartment or allow pets to sit on the luggage compartment cover. They could become a hazard to vehicle occupants in the event of sudden braking or in an accident.

### ! Note

- Make sure that the heating wires in the rear lid do not get damaged by objects scraping against them.
- The two inner attaching eyes on the left and right in the seatback ⇒ fig. 90 ① are not suitable for tying down cargo - risk of damage. Only the luggage compartment cover should be attached here.

### i Tips

- You can use the luggage compartment cover to store light weight clothing or articles but do not leave any heavy or sharp objects in the pockets of the clothing.
- Remember that placing clothing or articles on the luggage compartment cover can block the driver's vision in the rear view mirror. This also applies especially when you have to transport large objects.

- So that stale air can escape from the vehicle be sure not to cover the ventilation slot between the rear lid and the luggage compartment cover.

### Protective liner

*Dirty or wet objects can be transported under the cargo floor in a protective tray.*

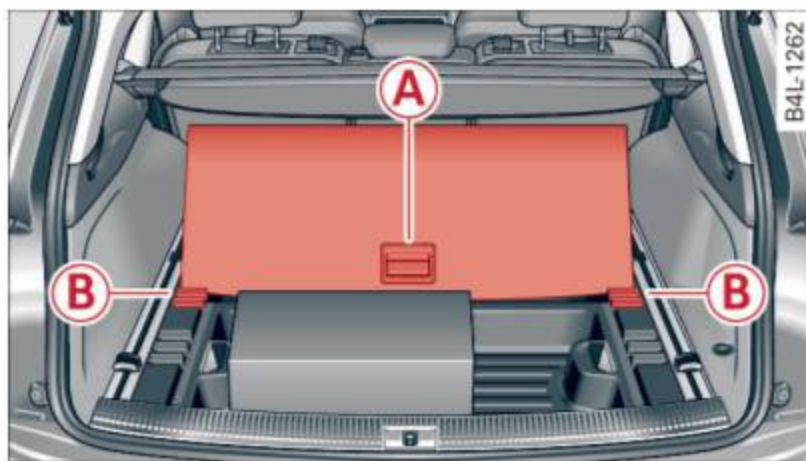

Fig. 92 Cargo floor: folded upright

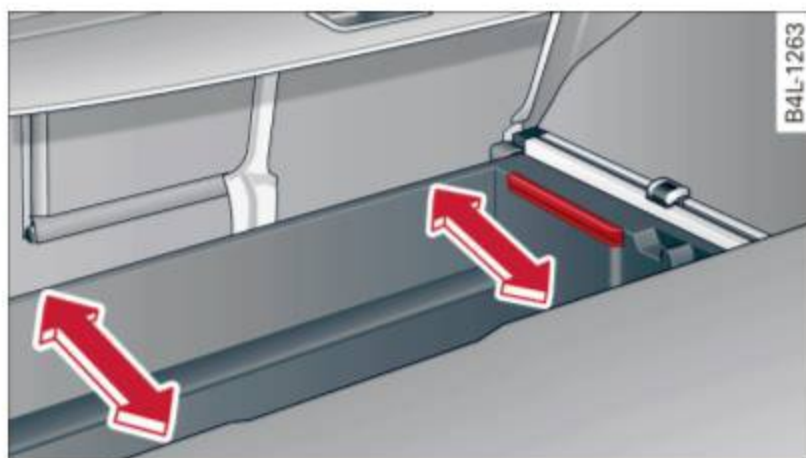

Fig. 93 Removing the cargo floor

### Setting up the cargo floor

- ▶ Open the rear lid.
- ▶ Set up cargo floor with the help of the handle **A** ⇒ fig. 92 and adjust the outside edges in the recesses **B**.
- ▶ Lay the items in the protective tray.

### Folding the cargo floor up

- ▶ Open the rear lid.
- ▶ Fold the cargo floor up to the seatback with the help of the handle **A**.

### Removing the cargo floor, installing

- ▶ Open the rear lid.
- ▶ Fold the cargo floor up to the seatback with the help of the handle **A**.
- ▶ To remove, pull the entire cargo floor out of the guides -arrow- ⇒ fig. 93 in the direction of the rear of the vehicle.

- ▶ To install the cargo floor, set the front of it into the guides and push it in the direction of the seatback until it engages.

You can also store small items **under** the cargo floor.

The storage room in the protective tray can be enlarged by folding the cargo floor forward or removing it.

The protective tray can be removed upward by the grip.

On vehicles with **6 or 7 seats\*** the cargo floor cannot be folded up, only raised. If the cargo floor is removed, the hooks must be pushed into the guides under the third row seating when the cargo floor is re-installed.

### ! WARNING

When the cargo floor is folded upright, the items being transported must not exceed the maximum cargo height, 2/3 of the cargo floor space with the floor folded forward, or a weight of about 33 lb. (15 kg).

### i Tips

We recommend that you use a tie-down strap to secure objects to the tie-down eyelets on the right and left sides of the vehicle.

### Ski sack

Applies to vehicles: with ski sack

*The ski sack allows a maximum of 4 pairs of skis or 2 snowboards to be carried inside the vehicle.*

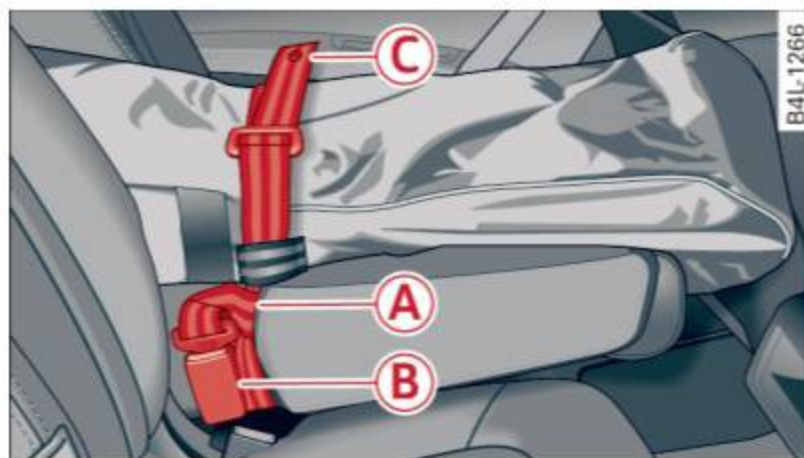







Fig. 94 Securing the ski sack at the center rear seat belt buckle

## Loading

- ▶ Fold the center seatback forward  
⇒ page 79.
- ▶ Remove the sack from the luggage compartment and unfold it.
- ▶ Place the empty sack over the lowered seatback so that the end with the zip fastener is in the luggage compartment.
- ▶ Load objects from the luggage compartment into the ski sack ⇒ .

## Securing

- ▶ Insert the ski sack strap  ⇒ fig. 94 into the center seat belt buckle .
- ▶ Pull the securing strap tight by the free end of the belt .
- ▶ Vehicles with 6 seats\*: The ski sack has two straps with hooks on the underside. Hang the hooks into the luggage compartment by the rear fastening eyes and pull the securing strap tight by the free end .

## Storage

- ▶ Release the securing strap for the sack.
- ▶ Pull the sack to the rear over the folded down seatback.
- ▶ Raise the seatback until it is securely latched.
- ▶ Fold up the empty sack.
- ▶ Stow the ski sack in the luggage compartment so that it cannot slide around.

### WARNING

- The ski sack is intended only for the transportation of skis, snowboards and other light objects. To reduce the risk of serious personal injury never transport heavy or pointed objects in the ski sack.
- When braking rapidly or during an accident the load could be displaced and cause injury to occupants.
- Sharp edges on the load must be covered for protection. Always fasten the belt tightly around the sack and its contents ⇒ fig. 94.

### Tips

Never stow the ski sack away if it's wet or damp (for example, snow melting from skis). Let it dry completely before you stow it away.

## Roof rack

### First things first

*A roof rack can be fitted to carry additional luggage on the roof.*

- ▶ Always read and follow the instructions provided by the roof rack manufacturer when installing the roof rack system.

If you are transporting luggage or other objects on the roof, please note the following:

- Your vehicle has specially designed aerodynamic roof rails. Only install a roof rack specifically designed for your model. Contact the nearest authorized Audi dealer for information on approved modular roof racks for your vehicle.
- These approved roof racks are the basis for a complete roof rack system. Additional attachments for the basic roof rack are necessary to safely transport luggage, bicycles, surf boards, skis or small boats. All necessary hardware for these systems is available at your authorized Audi dealer.
- We recommend that you keep the installation instructions for your roof rack system together with your Owner's literature in the vehicle.

### When should the roof rack be removed?

- Before going through an automatic car wash (it is best to ask the car wash operator for advice).
- When not in use, to reduce fuel consumption, wind noise and to guard against theft.

### WARNING

- Use of an unapproved roof rack or incorrect mounting of an approved roof rack

can cause the roof rack or the items attached to it to fall off the roof onto the road.

- Objects falling from the roof of a vehicle can cause a crash and personal injury.
- Only mount the system between the markings shown in ⇒ *page 84, fig. 95*.
- The roof rack system must be installed exactly according to the instructions provided.

### ! Note

- Your vehicle warranty does not cover any damages to the vehicle caused by using roof racks or mounting structures not approved by Audi for your vehicle. The same applies to damage resulting from incorrect roof rack installation.
- Always check the roof rack mountings and hardware before each trip and during a trip to make sure everything is securely tightened. If necessary, retighten the mountings and check the entire system from time to time.
- After mounting a roof rack system, or when you transport objects on the roof of your vehicle, the height of the vehicle is naturally increased. Be careful when driving under low bridges or in parking garages for example. This could cause damage to the load and even the vehicle itself.

### Roof rack mounting locations

Roof racks must be installed only at the locations marked on the roof rails.

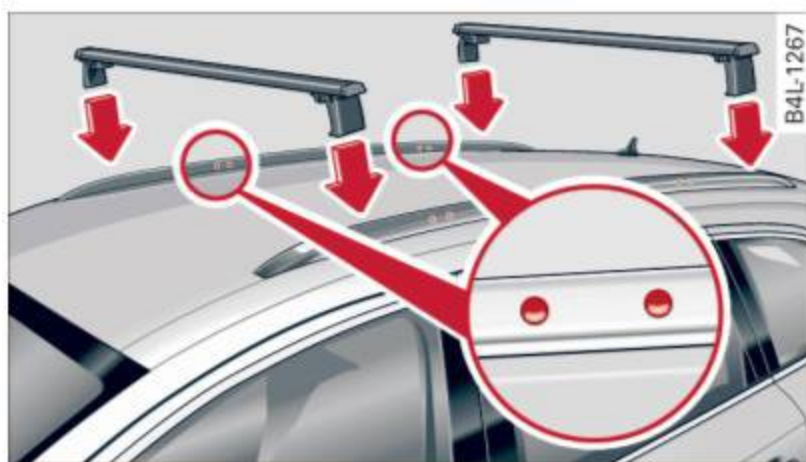

Fig. 95 Roof rails: front and rear mounting locations

Mount the front and rear cross bars between the punched markings on the inside of the roof railings ⇒ *fig. 95*. The markings are located on the inside of the railings.

### Loading the roof rack

Always distribute loads evenly. Make sure anything on the roof rack is securely tied down.

- ▶ Always distribute the loads on the roof rack evenly.
- ▶ Always attach items to the roof rack securely before you drive off.

The maximum permissible roof weight is **220 lb (100 kg)**. The roof weight is made up of the weight of the roof rack system and the weight of the object being transported.

When using a roof rack system which has a lower load carrying capacity, you must not use up the total maximum permissible load carrying capacity specified above. Instead, you should load the roof rack system only to the maximum capacity specified by the manufacturer of the roof rack system.

### ! WARNING

Weak, damaged or improper straps used to secure items to the roof rack can fail during hard braking or in a collision and cause serious personal injury.

- Make sure the roof rack is installed exactly as specified above ⇒ *page 84*.
- Always use suitable mounting straps for securing items to the roof rack to help prevent items from shifting or flying forward.
- Items on the roof rack must always be securely mounted.
- The use of a roof rack can negatively affect the way a vehicle handles. Cargo that is large, heavy, bulky, long or flat will have a greater negative influence on the vehicle's aerodynamics, center of gravity and overall handling. Always drive slowly, avoid sudden braking and

maneuvers when transporting cargo on the roof of your vehicle.

- Never exceed the maximum permissible load carrying capacity of the roof of your vehicle, the permissible axle weights and the permissible total weight of your vehicle ⇒ *page 320, Weights.*

**! Note**

Make sure that the opened rear lid does not come in contact with the cargo on the roof.

**🌳 For the sake of the environment**

As a result of the increased wind resistance created by a roof rack, your vehicle is using fuel unnecessarily. So remove the roof rack after using it.

## Cupholder

### Front cupholders

The cupholders are located in the center armrest.



Fig. 96 Center armrest: Beverage holder

- ▶ Open the cover at the recess on the side ⇒ *fig. 96.*

A maximum of two beverages can be accommodated in the center armrest. The second beverage holder is located under a cover.

**! WARNING**

Spilled hot liquid can cause an accident and personal injury.

- Never carry any beverage containers with hot liquids, such as hot coffee or hot tea,

in the vehicle while it is moving. In case of an accident, sudden braking or other vehicle movement, hot liquid could spill, causing scalding burns. Spilled hot liquid can also cause an accident and personal injury.

- Use only soft cups in the cupholder. Hard cups and glasses can cause injury in an accident.

**! Note**

Only drink containers with lids should be carried in the cupholder. Liquid could spill out and damage your vehicle's electronic equipment or stain the upholstery, etc.

### Cupholder in the rear center armrest

The cupholder is located in the center console.

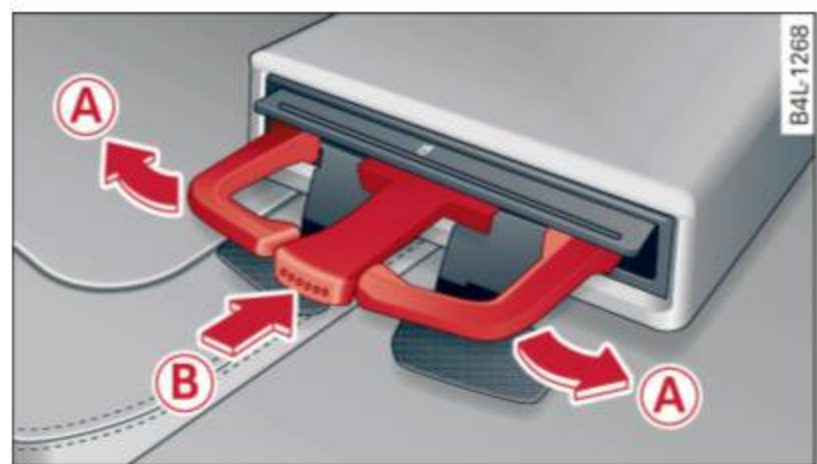



Fig. 97 Rear center armrest: cupholder extended

- ▶ To open the cupholder, press on the symbol  ⇒ *fig. 97.*
- ▶ To close the cupholder, press the corrugated area **B** and fold the cover down.

The holder **A** adjusts to the beverage holder. The cupholder is designed to hold no more than two cups or cans.

**! WARNING**

Spilled hot liquid can cause an accident and personal injury.

- Never carry any beverage containers with hot liquids, such as hot coffee or hot tea, in the vehicle while it is moving. In case of an accident, sudden braking or other vehicle movement, hot liquid could spill,

causing scalding burns. Spilled hot liquid can also cause an accident and personal injury.

- Use only soft cups in the cupholder. Hard cups and glasses can cause injury in an accident.

### Note

Only drink containers with lids should be carried in the cupholder. Liquid could spill out and damage your vehicle's electronic equipment or stain the upholstery, etc.

### Beverage holders in the door pockets

*There is a beverage holder in all four doors.*



Fig. 98 Section of door panel: Beverage holder

The beverage holders in the door pockets are suitable for 1 to 1.5-liter bottles.

### WARNING

Spilled hot liquid can cause an accident and personal injury.

- Never carry any beverage containers with hot liquids, such as hot coffee or hot tea, in the vehicle while it is moving. In case of an accident, sudden braking or other vehicle movement, hot liquid could spill, causing scalding burns. Spilled hot liquid can also cause an accident and personal injury.
- Use only soft cups in the cupholder. Hard cups and glasses can cause injury in an accident.

### Note

Only drink containers with lids should be carried in the cupholder. Liquid could spill

out and damage your vehicle's electronic equipment or stain the upholstery, etc.

## Rear ashtray



Fig. 99 Rear ashtray

### To open ashtray

- ▶ Touch the lid to open the ashtray.

### Removing ashtray insert

- ▶ Press the front of the open lid downward in the direction of the arrow ⇒ *fig. 99* - the ashtray insert pops out slightly.
- ▶ Lift the ashtray insert up and out.

### Reinstalling ashtray insert

- ▶ Open the lid on the ashtray insert and press the insert into the housing as far it can go.

### WARNING

Never put waste paper in the ashtray. Hot ashes or other hot objects in the ashtray could set waste paper on fire.

## Outlet

An electrical accessory can be connected to the 12-volt power outlet.

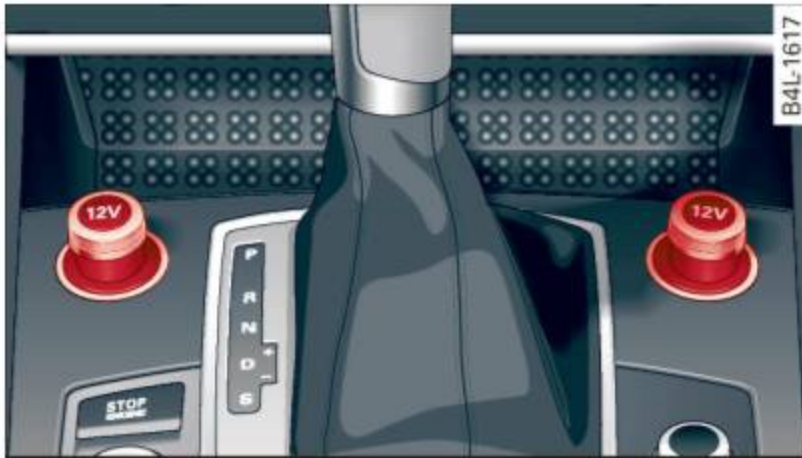

Fig. 100 Section from center console: 12-volt outlets

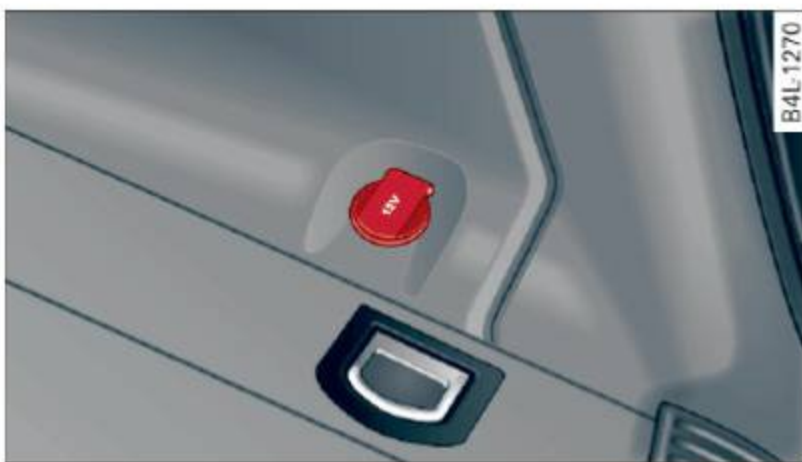

Fig. 101 Section from right side of luggage compartment: 12-volt outlet

- ▶ Remove the cover from the outlet ⇒ *fig. 100*.
- ▶ Lift up the cover for the outlet ⇒ *fig. 101*.
- ▶ Plug in appliance to be used.

The 12-volt outlets can be used for electrical accessories. The power input must not exceed 120 watts.

There may be just one outlet at the front of the center console depending on your model. There are two additional 12-volt outlets in the rear center console.

Before you purchase any accessories, always read and follow the information in ⇒ *page 327, Additional accessories and parts replacement*.

### WARNING

The outlet plus any appliances plugged into it remain functional even if the ignition is switched off or the ignition key is re-

moved. Never leave children inside the vehicle without supervision.

### Note

To avoid damaging the outlet, only use plugs that fit properly.

### Tips

When the engine is off and accessories are still plugged in and are on, the vehicle battery can still be drained.

## Storage

### General overview

There are numerous places to store items in your vehicle.

|   |                  |
|---|------------------|
| Glove compartment                       | ⇒ <i>page 88</i> |
| Cooling box in glove compartment        | ⇒ <i>page 88</i> |
| Storage compartment in roof             | ⇒ <i>page 89</i> |
| Coat hooks                              | ⇒ <i>page 89</i> |
| Storage in the door panels              | ⇒ <i>page 89</i> |
| Storage net in footwell                 | ⇒ <i>page 89</i> |
| Storage net in the front seat-backs     | ⇒ <i>page 90</i> |
| Storage net in luggage compartment      | ⇒ <i>page 90</i> |
| Storage compartment beneath cargo floor | ⇒ <i>page 82</i> |

### WARNING

- Always remove objects from the instrument panel. Any items not stored could slide around inside the vehicle while driving or when accelerating or when applying the brakes or when driving around a corner.
- When you are driving make sure that anything you may have placed in the center console or other storage locations cannot fall out into the footwells. In case of sudden braking you would not be able to brake or accelerate.

- Any articles of clothing that you have hung up must not interfere with the driver's view. The coat hooks are designed only for lightweight clothing. Never hang any clothing with hard, pointed or heavy objects in the pockets on the coat hooks. During sudden braking or in an accident - especially if the airbag is deployed - these objects could injure any passengers inside the vehicle.

### Glove compartment

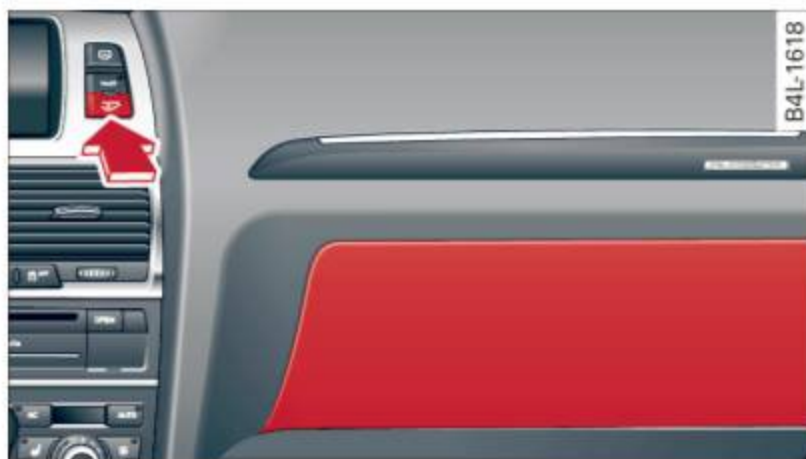

Fig. 102 Unlocking button for glove compartment

#### To open glove compartment

- ▶ Press the button  ⇒ *fig. 102* (arrow) - the lid opens automatically.

#### To close glove compartment

- ▶ Push the glove compartment lid up until the lock engages.

In the glove compartment lid you will find a place to store a pen and a pad of paper.

#### WARNING

To reduce the risk of personal injury in an accident or sudden stop, always keep the glove compartment closed while driving.

#### Tips

Should you not be able to open the glove compartment as described, make sure the valet key function is not activated ⇒ *page 41*.

### Cooling box in glove compartment

The cooling box works only when the air-conditioning is in cooling mode.

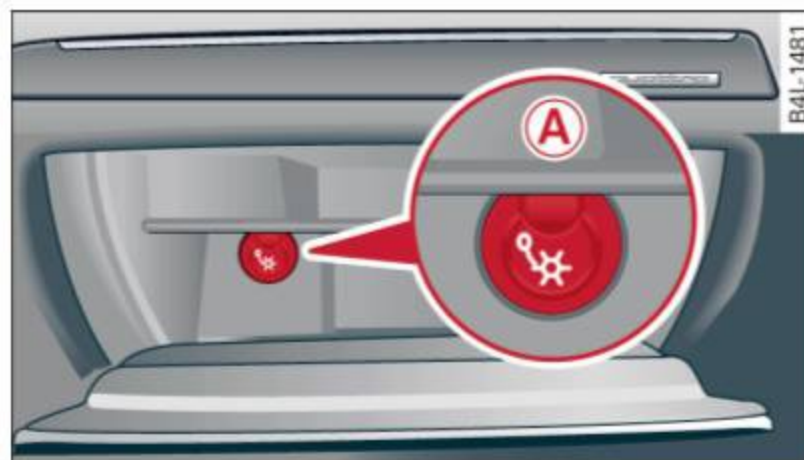

Fig. 103 Glove box with cooling box open and switched on

- ▶ Open the glove compartment ⇒ *page 88*, *fig. 102*.
- ▶ Turn the rotary switch **A** counter-clockwise to switch the cooling on. The symbols on the rotary switch must be displayed ⇒ *fig. 103* accordingly.
- ▶ Turn the rotary switch **A** clockwise to switch the cooling off.

The cooling box works only in the cooling mode. If the climate control is in the heating mode, we recommend switching the cooling box off.

### Emergency unlocking of glove compartment

The glove compartment can be unlocked in an emergency.

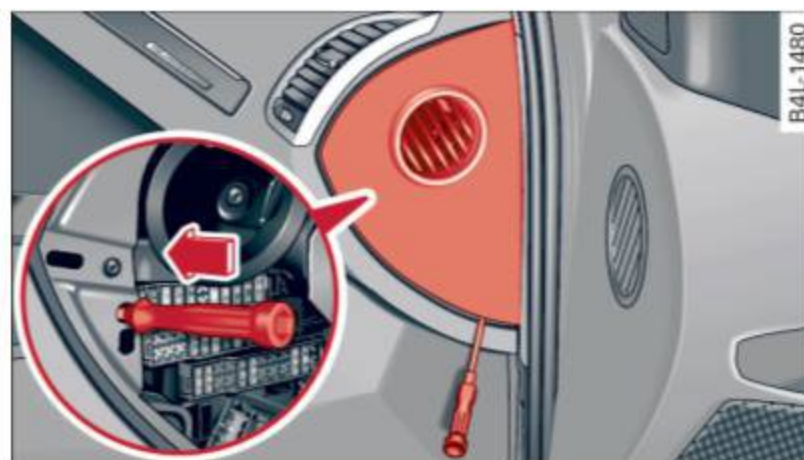

Fig. 104 Instrument panel right: pry off security cover

- ▶ Remove the cover with the aid of a screwdriver ⇒ *fig. 104*.
- ▶ Now press the locking pin inward with the screwdriver.

**Storage compartment in roof**



Fig. 105 Storage compartment in roof

- ▶ To open the lid you have to touch the bar ⇒ fig. 105 (Arrow). The lid opens automatically.
- ▶ To close the lid, push it up until it engages.

**! WARNING**

Always keep the lid closed while driving to reduce the risk of injury during a sudden braking maneuver or in the event of an accident.

**Coat hooks**



Fig. 106 Coat hooks at rear doors

**! WARNING**

- Hang clothes in such a way that they do not impair the driver's vision.
- The coat hooks must only be used for lightweight clothing. Do not leave any heavy or sharp edged objects in the pockets which may interfere with the side curtain airbag deployment and can cause personal injury in a crash.
- Do not use coat hangers for hanging clothing on the coat hooks as this can in-

- interfere with proper deployment of the side curtain airbags in an accident.
- Do not hang heavy objects on the coat hooks, as they could cause personal injury in a sudden stop.

**Storage in the door panels**

There is a storage compartment in the interior door panel.

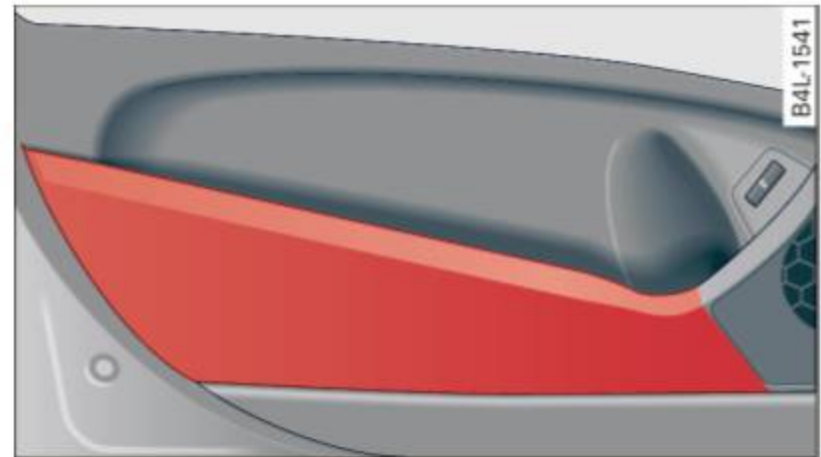

Fig. 107 Door panel with storage compartment.

**! WARNING**

Use the storage compartments in the door panels only for holding small objects, which do not protrude from the compartment, so that the effective range of the side airbags is not compromised.

**Storage net in the footwell**

There is a storage net in the passenger's footwell.

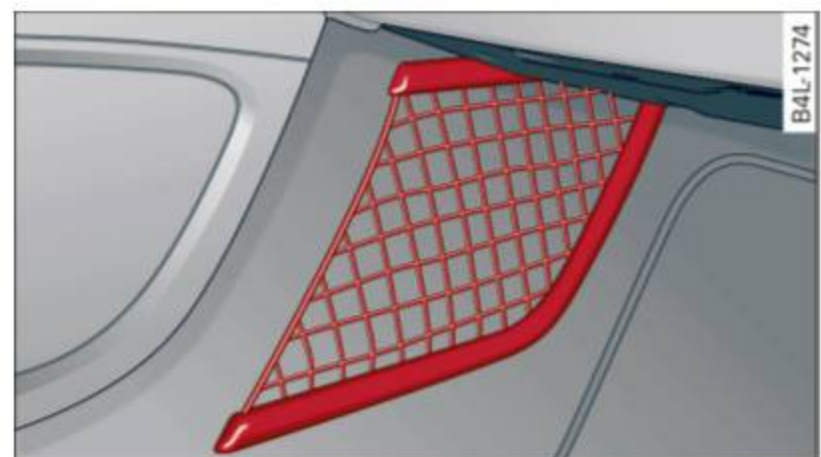

Fig. 108 Storage net in passenger's footwell

**i Tips**

Do not keep any sharp or pointed objects in the storage net - danger of injury!

### Storage net in the seatbacks

There is a storage net behind both front seatbacks.

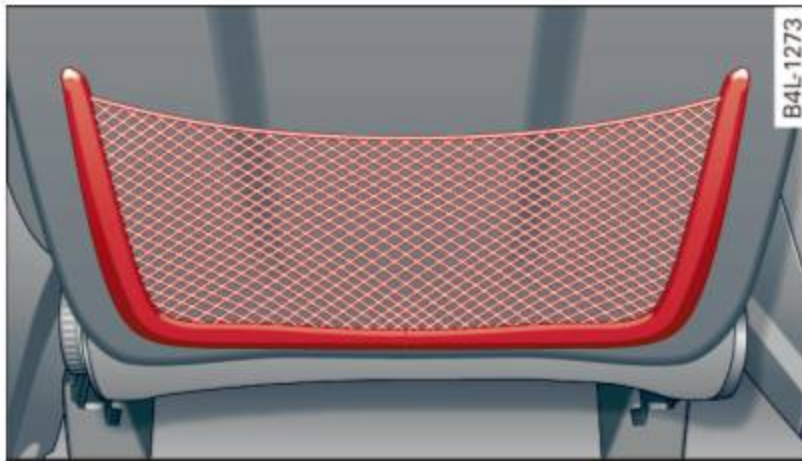

Fig. 109 Storage net on the front seatback

#### **i** Tips

Do not keep any sharp or pointed objects in the storage net - danger of injury!

### Storage net in luggage compartment

There is a storage net on the left side of the luggage compartment.

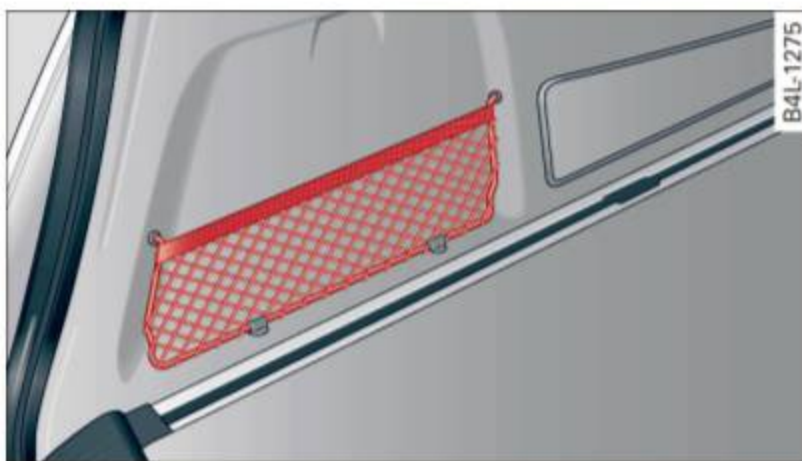

Fig. 110 Storage net in luggage compartment

The storage net can be compacted by pushing it down on the guides at the side, if necessary ⇒ fig. 110.

#### **i** Tips

Do not keep any sharp or pointed objects in the storage net - danger of injury!

## Warm and cold

### Climate control

#### Description

The air conditioner is fully automatic and is designed to maintain a comfortable and uniform climate inside the vehicle.

We recommend the following settings:

- ▶ Set the temperature to 72 °F (+22 °C).
- ▶ Press the **AUTO** button.

With this setting, you attain maximum comfort in the least amount of time. Change this setting, as desired, to meet your personal needs.

The climate controls are a combination of heating, ventilation and cooling systems, which automatically reduce humidity and cool the air inside your vehicle.

The air temperature, air flow and air distribution are automatically regulated to achieve and maintain the desired passenger compartment temperature as quickly as possible.

The system automatically compensates for changes in outside temperature and for the intensity of the sunlight entering the vehicle. We recommend you use the **Automatic** mode ⇒ *page 94* for year-round comfort.

#### Please note the following:

Turn on the air conditioner to reduce humidity in the vehicle. This also prevents the windows from fogging up.

When the outside temperature is high and the air is very humid, **condensation** from the evaporator may drip under the vehicle. This is normal and does not indicate a leak.

If the outside temperature is low, the fan normally only switches to a higher speed once the engine coolant has warmed up sufficiently.

The air conditioner temporarily switches off when you drive off from a standstill using full throttle to save engine power.

The compressor also switches off if the coolant temperature is too high, so that the engine can be adequately cooled under extreme loads.

#### Air pollutants filter

The air pollutants filter (a combined particle filter and activated charcoal filter) reduces or prevents outside air pollution (dust, or pollen) from entering the vehicle. The air is also filtered in air recirculation mode.

The air pollutants filter must be changed at the intervals specified in your Warranty & Maintenance booklet, so that the air conditioner can properly work.

If you drive your vehicle in an area with high air pollution, the filter may need to be changed more frequently than specified in your Audi Warranty & Maintenance booklet. If in doubt, ask your authorized Audi Service Advisor for advice.

#### Key coded settings

The air conditioner settings selected are automatically stored and assigned to the key being used. When the vehicle is started, the air conditioner automatically selects the settings assigned to that key. This way every driver will maintain his/her own personal settings and does not have to reset them manually.

If a different driver uses your key and changes the air conditioner settings, the latest adjustments will erase and replace the settings you have stored.

#### Energy management

To prevent the battery from being discharged and to restore the balance of energy, components which require large amounts of energy are temporarily cut back or switched off ⇒ *page 231*. Heating systems in particular require a great deal of energy. If you notice, for example, that the seat\* or rear window heating is not heating, they have been temporarily cut back or switched off by **energy management**. These systems are available again as soon as the energy balance has been restored. ▶

### WARNING

Reduced visibility is dangerous and can cause accidents.

- For safe driving it is very important that all windows be free of ice, snow and condensation.
- Completely familiarize yourself with the proper use and function of the heating and ventilation system and especially how to defog and defrost the windows.
- Never use the windshield wiper/washer system in freezing weather until you have warmed the windshield first, using the heating and ventilation system. The washer solution may freeze on the windshield and reduce visibility.

### Note

- If you suspect that the climate control system has been damaged, switch the system off to avoid further damages, and have it inspected by a qualified dealership.

- Repairs to the Audi air conditioner require special technical knowledge and special tools. Contact an authorized Audi dealer for assistance.

### Tips

- Keep the air intake slots (in front of the windshield) free from ice, snow and debris in order to maintain the proper function of the climate control system.
- Air inside the vehicle escapes through air vents located in the side trim panels beneath the rear side windows. Make sure that the outlet slots are not covered by clothing, etc.
- Climate control works most effectively if the windows and the Panoramic sliding sunroof\* are closed. However, if the interior of a parked vehicle is extremely hot from the sun's rays, briefly opening the windows can speed up the cooling process.

## Controls

*This overview will help you to familiarize yourself with the air conditioning controls.*

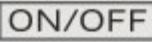











**Fig. 111** Air conditioning control elements

The left display indicates the temperature selected for the driver's side, the right display indicates the temperature selected for the passenger's side.

The settings you make are shown in the MMI display for a few seconds when MMI is turned on. ▶

Each function is turned on or off by briefly pressing the corresponding button. The indicator light in the button illuminates when the function is active.

| Button(s)   | Function                            |
|---|-------------------------------------|
|                          | Climate control on/off<br>⇒ page 93 |
|                          | Air conditioner on/off<br>⇒ page 93 |
|                          | Automatic mode<br>⇒ page 94         |
| Regulator <sup>a)</sup>  | Temperature selection<br>⇒ page 94  |
|                          | Seat heating*<br>⇒ page 100         |
|                        | Seat ventilation*<br>⇒ page 100     |
|                        | Fan<br>⇒ page 94                    |
|                        | Air distribution<br>⇒ page 94       |
|                        | Defrost<br>⇒ page 94                |
|                        | Manual recirculation<br>⇒ page 95   |
|                        | Heated rear window<br>⇒ page 95     |

<sup>a)</sup> The regulator is also used to set the fan speed, air distribution, seat heating and seat ventilation.

### Synchronizing climate control

By pressing and holding the regulator on the driver's side, the temperature setting on the driver's side can be switched to the passenger's side, and vice versa. The new temperature is shown in the display.

### Synchronizing four-zone automatic comfort air conditioning\*

By pressing and holding the regulator on the driver's side, the temperature setting on the driver's side can be switched to the passenger's side and to the outer rear seats. The new temperature is shown in the display.

By simultaneously pressing and holding the regulators on the driver's side and front passenger's side, the temperature setting on the driver's side can be switched to the front passenger's side. The new temperature is shown in the display.

#### Tips

The grille on the controls must remain unobstructed and must not be taped over. Measuring sensors are located behind it.

### Turning on and off

#### Turning the climate control on

- ▶ Press the  button, or
- ▶ Press the  button.

#### Turning the climate control off

- ▶ Press the  button to switch the climate control off and to block the air supply from the outside.

The air conditioner turns back on when you press the **temperature regulator** or one of the buttons.

#### Tips

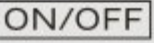
With the ignition turned off, you can activate the residual heat function by pressing the  button. The residual heat from the coolant can be used to heat the vehicle interior.

### Air Conditioner On/Off

*Switching off the air conditioner saves fuel.*

- ▶ Press the  button to switch the air conditioner on or off.

When the air conditioner is switched on, the indicator lamp in the button will illuminate and the heating/ventilation system is controlled automatically.

Please keep in mind that with the air conditioner switched off, the interior temperature

cannot be lower than the outside temperature. The air will not be cooled or dehumidified. The windows can fog up.

### Automatic mode

*The automatic mode is the standard setting for all seasons.*

- ▶ Select temperature between 60 °F (+16 °C) and 84 °F (+28 °C).
- ▶ Press the  button.

Automatic operation ensures constant temperatures in the interior and dehumidifies the air inside the vehicle. Air temperature, volume and distribution are controlled automatically to reach or maintain the desired interior temperature as quickly as possible. Fluctuations in exterior temperature and the effects of temperature from the position of the sun are compensated for automatically.

This operating mode works only in the adjustable temperature range, from 60 °F (+16 °C) to 84 °F (+28 °C). If a temperature below 60 °F (+16 °C) is selected, **LO** appears in the display. At temperatures above 84 °F (+28 °C), **HI** is displayed. At both extreme settings, climate control runs continuously at maximum cooling or heating power. There is no temperature regulation.

### Setting the temperature

*Separate temperatures can be selected for the driver's and front passenger's side.*

- ▶ Rotate the regulator to the left to reduce the temperature, or to the right to increase the temperature.

The selected temperature appears on the climate control display. The temperature setting will also appear for a few seconds in the MMI display.

### Fan

*The automatically preset fan speed can be reduced or increased.*

- ▶ Press the  button.
- ▶ Rotate the regulator to the desired fan speed.

The climate control system automatically regulates fan speed depending on interior temperature. You can adjust the volume of air produced by the fan to your own requirements.

The fan speed setting will appear for a few seconds in the MMI display.



### Tips

It is possible that the fan speed may change automatically. This occurs to ensure that the desired temperature setting is reached as quickly as possible.

### Air distribution

*The automatically controlled air distribution can be changed manually.*

- ▶ Press the  button.
- ▶ Rotate the regulator to the desired setting.

You can adjust the air distribution so that air flows from specific vents. In position  air flows only to the windows, in position , it flows to the driver or passenger, and in position  it flows to the footwell. There are additional combinations available to adjust air distribution as needed.

To regulate air distribution automatically, switch to .

The air distribution setting will appear for a few seconds in the MMI display.

### Defrosting

*The windshield and side windows are rapidly defrosted or defogged.*

- ▶ Press the  button to turn on the defroster.

- ▶ Press the  button again, or press the **AUTO** button to turn it off.

Temperature is controlled automatically. The maximum amount of air flows mainly from the vents below the windshield.

To defog the rear side windows, the air vents in the door pillars should be open and directed at the windows.

### Manual air recirculation

*Air recirculation prevents exhaust fumes or other pollution from entering the vehicle.*

#### Turning on air recirculation

- ▶ Press the  button ⇒ 

#### Turning off air recirculation

- ▶ Press the  button again, or
- ▶ press the **AUTO** button, or
- ▶ press the .

In the air recirculation mode, the air in the passenger compartment is recirculated and filtered to prevent exhaust fumes and other pollution from entering the vehicle. We recommend that you use the manual air recirculation under the following conditions:

- when driving through tunnels
- in a traffic jam.

### **WARNING**

Do not use the air recirculation mode for extended periods of time. The windows could fog up since no fresh air can enter the vehicle. If the windows fog up, press the air recirculation button again immedi-

ately to switch off the air recirculation function or select defrost.

### Rear window defogger

*The rear window defogger clears the rear window of condensation.*

- ▶ Press the  button to turn the rear window defogger on and off.

The rear window defogger works only when the engine is running. The light in the switch will illuminate when the defogger is on.

The rear window defogger will switch off automatically after a short time. The time the rear window defogger remains on will vary depending on the outside temperature.

At very low outside temperatures, the rear window defogger can be switched on continuously by pushing the  button for more than 2 seconds. This remains stored until the ignition is switched off.

A rear window defogger that was switched on also remains stored for 15 minutes after the ignition is switched off. If the engine is restarted within these 15 minutes, the rear window defogger is also activated, depending on outside temperature. With a vehicle that is parked for a short time, the rear window defogger does not need to be manually activated again.

### **For the sake of the environment**

Turn the defogger off when the rear window is clear. When you save electricity, you save fuel.

## Air outlets

Air distribution determines the air flow to the individual vents.

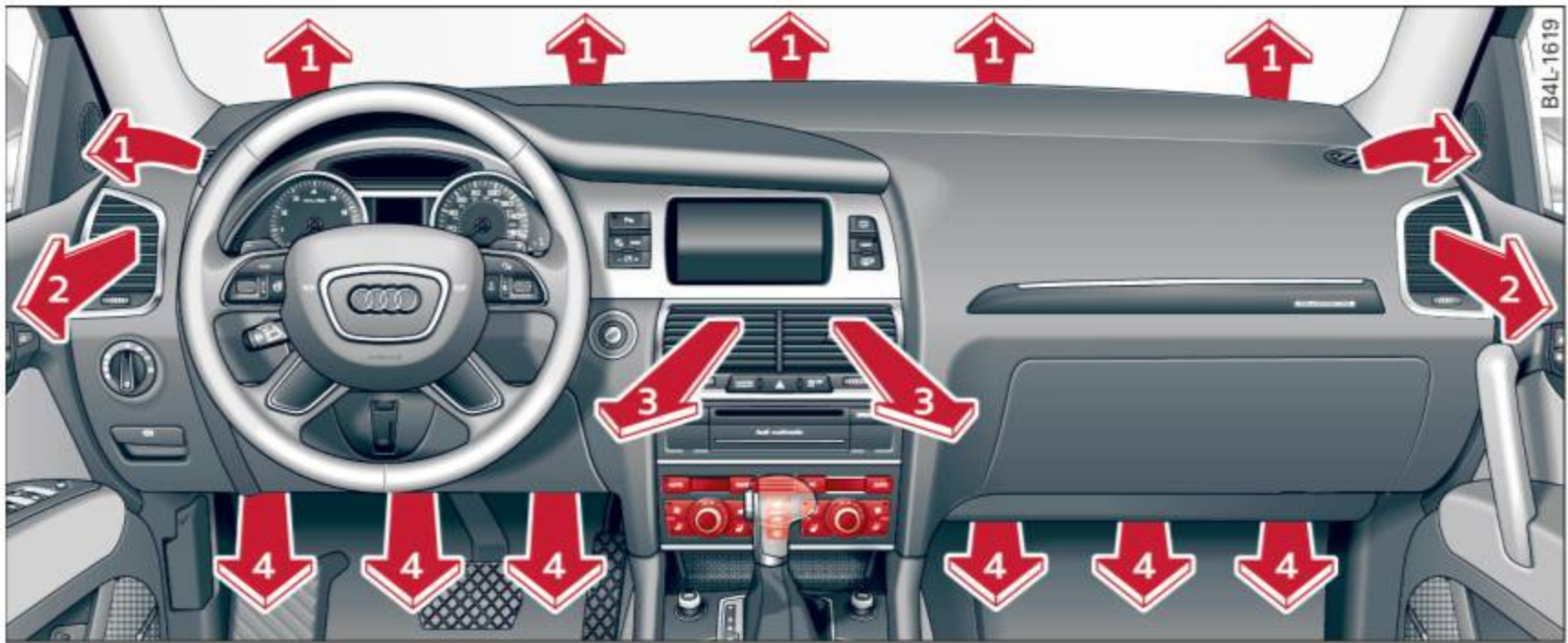

Fig. 112 Instrument panel: air outlet locations and airflow directions

### Air outlets ② and ③

- ▶ Rotate the horizontal thumb wheel located below the particular outlet to increase, reduce, or shut down the airflow from that outlet.
- ▶ To adjust the direction of the airflow from the outlet, move the tab in the center of the outlet in the desired direction. The direction of the air delivered from the vents can be adjusted horizontally and vertically.

- ① Air flows to windshield and to driver and front passenger side windows
- ② Air flows to driver/front passenger or to the driver and front passenger side windows
- ③ Air flows to driver/front passenger
- ④ Air flows to footwell

The air outlets are actuated either automatically or manually depending on the operating mode selected.

### **i** Tips

When climate control is working, cooled air will flow primarily from outlets ② and ③. To assure adequate cooling, outlets ② and ③ should never be completely closed.

### Air outlets in the rear

#### Outlets in the center console

- ▶ Rotate the thumbwheel located next to the outlet to open or close it.
- ▶ To adjust the direction of the airflow from the outlet, move the tab in the center of the outlet in the desired direction. The direction of the air delivered from the vents can be adjusted horizontally and vertically.

#### Outlets in the door pillars

- ▶ Rotate the horizontal thumb wheel located below the outlet to open or close it.
- ▶ To adjust the direction of the airflow from the outlet, move the tab in the center of the outlet in the desired direction. The direction of the air delivered from the vents can be adjusted horizontally and vertically.

The air outlets are actuated either automatically or manually depending on the operating mode selected. Heated or unheated fresh air, or cooled air flows from the vents.

The air outlets to heat the rear footwell are located under the front seats. ▶

### Tips

If the climate control system is operating in cooling mode, air flows primarily from the outlets in the center console and in the door pillars. To achieve adequate cooling, you should never close the outlets completely.

### Using climate control economically

Using the climate controls prudently can help save fuel.

When you use the air conditioner, engine power is reduced and fuel consumption increases. To save fuel, you should use the air conditioner only when necessary. Also please note the following points:

- ▶ To save fuel, turn off cooling mode by pressing the **AC** button (indicator light goes out).
- ▶ In addition, if you open the window or the Panoramic sliding sunroof\* while driving, turn off cooling mode by pressing the **AC** button (indicator light goes out).
- ▶ If the vehicle is extremely hot due to the heat of the sun, briefly open doors and windows.

### For the sake of the environment

By reducing the amount of fuel you use, you also reduce the amount of pollutants emitted into the air.

## Rear Air Conditioning

### Rear air conditioning - controls

Applies to vehicles: with four-zone automatic comfort air conditioning



*This overview is to assist you in familiarizing yourself with the rear air conditioning controls.*



Fig. 113 Rear air conditioning controls

The left display indicates the temperature selected for the rear left passenger, the right display indicates the temperature selected for the rear right passenger. If the settings for seat heating\*, air distribution or the air conditioning fan are changed, the relevant indicator will appear briefly on the display.

Functions are set by rotating the control or are switched on and off by tapping the buttons. The indicator light in the button illuminates when the function is active.

| Button(s)   | Function                            |
|---|-------------------------------------|
| <b>ON/OFF</b>   | Climate control on/off<br>⇒ page 98 |
| <b>AUTO</b>   | Automatic mode<br>⇒ page 98         |
| Regulator <sup>a)</sup> <b>- +</b>  | Temperature selection<br>⇒ page 98  |
|  | Seat heating*<br>⇒ page 101         |
|  | Fan<br>⇒ page 98                    |
|  | Air distribution<br>⇒ page 99       |

<sup>a)</sup> The regulator is also used to set the fan speed, air distribution and seat heating.

**Synchronizing rear air conditioning:** By pressing and holding the regulator on the rear left side, the temperature setting of the rear left side can be switched to the rear right side and vice versa. The new temperature is shown in the display.

### Turning on and off

Applies to vehicles: with four-zone automatic comfort air conditioning

#### Turning the climate control on

- ▶ Press the  button, or
- ▶ Press the  button.

#### Turning the climate control off

- ▶ Press the  button to switch the climate control off and to block the air supply from the outside.

The air conditioner turns back on when you press the **temperature regulator** or one of the buttons.

### Tips

If the power child safety lock is on, the rear air conditioning control element will not operate. In this case, dashes “---” will appear in the air conditioning control element display.

### Automatic mode in rear

Applies to vehicles: with four-zone automatic comfort air conditioning

*The automatic mode is the standard setting for all seasons.*

- ▶ Select temperature between 60 °F (+16 °C) and 84 °F (+28 °C).
- ▶ Press the  button.

Automatic operation ensures constant temperatures in the interior and dehumidifies the air inside the vehicle. Air temperature, volume and distribution are controlled automatically to reach or maintain the desired interior temperature as quickly as possible. Fluctuations in exterior temperature and the effects of

temperature from the position of the sun are compensated for automatically.

This operating mode works only in the adjustable temperature range, from 60 °F (+16 °C) to 84 °F (+28 °C). If a temperature below 60 °F (+16 °C) is selected, **LO** appears in the display. At temperatures above 84 °F (+28 °C), **HI** is displayed. At both extreme settings, climate control runs continuously at maximum cooling or heating power. There is no temperature regulation.

### Setting rear temperature

Applies to vehicles: with four-zone automatic comfort air conditioning

*The temperature can be separately adjusted for the rear left and right sides.*

- ▶ Rotate the regulator to the left to reduce the temperature, or to the right to increase the temperature.

The selected temperature appears on the climate control display.

### Rear fan

Applies to vehicles: with four-zone automatic comfort air conditioning

*The automatically preset fan speed can be reduced or increased.*

- ▶ Press the  button.
- ▶ Rotate the regulator to the desired fan speed.

The climate control system automatically regulates fan speed depending on interior temperature. You can adjust the volume of air produced by the fan to your own requirements.

### Tips

It is possible that the fan speed may change automatically. This occurs to ensure that the desired temperature setting is reached as quickly as possible.



## Rear air distribution

Applies to vehicles: with four-zone automatic comfort air conditioning

*The automatically controlled air distribution can be changed manually.*

- ▶ Press the  button.
- ▶ Rotate the regulator to the desired setting.

You can adjust the air circulation so that air flows from specific vents.

- In position , all air flows from the vents in the center console and the outlets to the door pillars.
- In position , air flows from the outlets in the door pillars.
- In position , air flows from the outlets under the front seats.

There are additional combinations available to adjust air distribution as needed.

To regulate air distribution automatically, switch to **AUTO**.

## Basic settings

### General

*The basic climate control settings can be adjusted in the MMI.*

- ▶ Select: **CAR** function button > **AC** control button. Or
- ▶ Select: **CAR** function button > **Car systems\*** control button > **AC**.

The following functions can be selected:

- Auto recirculation ⇒ *page 99*
- Synchronization ⇒ *page 99*
- Supplementary heater\* ⇒ *page 100*
- Rear operation\* ⇒ *page 100*

## Automatic recirculation mode

*An air quality sensor detects increased concentrations of pollutants in the outside air and automatically switches to recirculation mode.*

We recommend that you always keep automatic air recirculation ON to prevent polluted outside air from entering the vehicle interior.

If the **air quality sensor** located in the air conditioning system detects polluted outside air, the sensor decides whether the air pollution can be reduced by the factory-installed pollutant filter or whether it is necessary to switch to air recirculation. With heavy concentrations of pollutants, the air conditioning system is switched automatically to recirculation mode and the supply of outside air is blocked. As soon as the concentration of pollutants in the outside air drops, fresh air is supplied to the vehicle interior again.

In the event that the windows fog up during automatic air recirculation, you must press the  button immediately.

Under certain operating conditions, automatic air recirculation is switched off automatically. With outside temperatures below about 50 °F (+10 °C), automatic air recirculation is limited to 30 seconds. With outside temperatures below about 30 °F (-1 °C) and with the air conditioner switched off, the automatic air recirculation is limited to 15 seconds.

## Synchronization

*One climate control setting for the driver and front passenger seats.*

With synchronization active, the driver's settings are adopted for the passenger or vice versa. All the other settings that were made are transferred to the other seat. This includes all the climate control settings, except for the seat heating/ventilation\*.

If a different setting is selected at a “synchronized seat”, synchronization is cancelled.

## Synchronization

Applies to vehicles: with four-zone automatic comfort air conditioning



*One climate control setting for all seats.*

With synchronization active, the driver's settings are adopted for the front passenger and the rear left and right seats. All the other settings that were made are transferred to the other seats. This includes all the climate control settings, except for the seat heating/ventilation\*.

If a different setting is selected at a "synchronized seat", synchronization is cancelled.

## Supplementary heater

Applies to vehicles: with diesel engine



- ▶ Select:  function button > **AC** control button > **Suppl. heater**. Or
- ▶ Select:  function button > **Car systems\*** control button > **AC** > **Suppl. heater**.

Vehicles with diesel engines are equipped with a supplementary heater to warm the interior of the vehicle more quickly. The supplementary heater switches itself on and off automatically when the outside temperature is below 50 °F (10 °C) and the engine is running, depending on the coolant temperature, interior temperature and the selected temperature.

## Rear operation

Applies to vehicles: with four-zone automatic comfort air conditioning

*The air conditioning in the rear of the vehicle can be controlled from the cockpit.*

- ▶ Select:  function button > **AC** control button > **Rear operation**. Or
- ▶ Select:  function button > **Car systems\*** control button > **AC** > **Rear cabin settings**.

The driver or front passenger can control the air conditioning in the rear of the vehicle using *his/her* own controls.

## Heated Seats

### Heated front seats

Applies to vehicles: with electrically heated front seats

*The seat cushion and the seatback of the front seats can be heated electrically.*

- ▶ Press the  button.
- ▶ Rotate the regulator to the desired setting.

In position 0 the heating for the seats is turned off. The range of adjustment is between 1 and 6.

The heater for the front seats can be turned on when the weight of the particular seat's occupant is detected. However, the front seats can be pre-heated for about 10 minutes using the activated seat heater. After this time has elapsed, the seat heater automatically turns off if it does not detect an occupant's weight for the particular seat.

### WARNING

Individuals with reduced sensitivity to pain or temperature could develop burns when using the seat heating function. To reduce the risk of injury, these individuals should not use seat heating.

### Note

To avoid damage to the heating elements in the seats, do not kneel on the seats or place heavy loads on a small area of the seat.

### Tips

Please note that the weight of objects placed on the seat will also be detected. This weight may be enough to cause the seat heater to turn on.

### Front seat ventilation

Applies to vehicles: with front seat ventilation

*The seat cushion and the seatback on the front seats can be ventilated.*

- ▶ Press the  button.
- ▶ Rotate the regulator to the desired setting. ▶

When the regulator is in the 0 position, the seat ventilation is switched off. The range of adjustment is between 1 and 6.

### Heated rear seats

Applies to vehicles: with heated rear seats

*The seat cushions and seatbacks of the two outer rear seats can be heated electrically.*

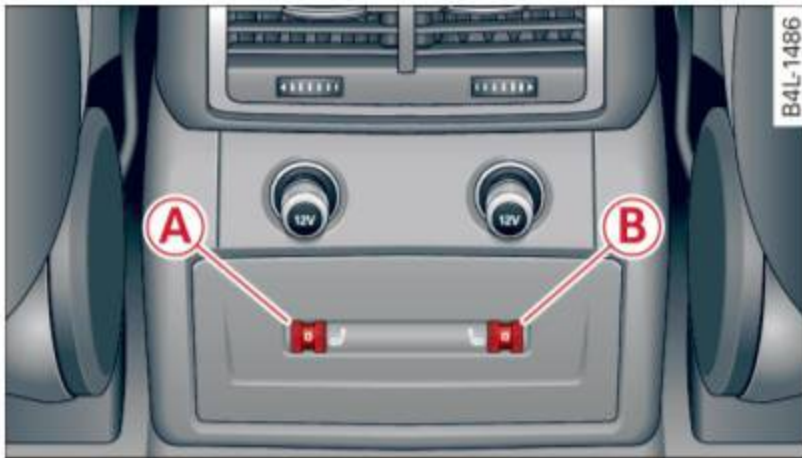

Fig. 114 Center console rear: Heated seats



Fig. 115 Center console rear: Seat heating with four-zone automatic comfort air conditioning\*

### Rear seat heating

- ▶ Rotate the thumb wheel ⇒ *fig. 114* **A** to turn on and adjust the heating for the left rear seat.
- ▶ Rotate the thumb wheel **B** to turn on and adjust the heating for the right rear seat.

### Rear seat heating with four-zone automatic comfort air conditioning\*

- ▶ Press the  button. ⇒ *fig. 115*.
- ▶ Rotate the regulator to the desired setting.

In position 0 the heating for the seats is turned off. The range of adjustment is between 1 and 6.

The heater for the outer rear seats can be turned on when the weight of the particular seat's occupant is detected. However, the rear

seats can be pre-heated for about 10 minutes using the activated seat heater. After this time has elapsed, the seat heater automatically turns off if it does not detect an occupant's weight for the particular seat.

### WARNING

Individuals with reduced sensitivity to pain or temperature could develop burns when using the seat heating function. To reduce the risk of injury, these individuals should not use seat heating.

### Note

To avoid damage to the heating elements in the seats, do not kneel on the seats or place heavy loads on a small area of the seat.

### Tips

Please note that the weight of objects placed on the seat will also be detected. This weight may be enough to cause the seat heater to turn on.

### Steering wheel heating

Applies to vehicles: with steering wheel heating

*The steering wheel can be heated electrically.*



Fig. 116 Steering wheel: button for steering wheel heating

- ▶ Press the  button to turn the steering wheel heating on and off ⇒ *fig. 116*. The message **Steering wheel heating on !** or **Steering wheel heating off !** appears in the instrument cluster display. ▶

A nearly constant temperature is maintained when the steering wheel heating is switched on.

The last setting selected for the steering wheel heating (on or off) is automatically saved when the vehicle is shut off and is assigned to the remote key.

## On the road

### Steering

#### Manually adjustable steering wheel

Applies to vehicles: with manually adjustable steering wheel

*The height and reach of the steering wheel can be adjusted.*



Fig. 117 Lever under the steering column

First, adjust the driver's seat correctly.

- ▶ Pull the lever ⇒ *fig. 117 -Arrow-* ⇒ ⚠.
- ▶ Move the steering wheel to the desired position.
- ▶ Push the lever against the steering column until it locks.

There must be at least 10 inches (25 cm) between your chest and the center of the steering wheel. If you cannot sit more than 10 inches (25 cm) from the steering wheel, see if adaptive equipment is available to help you reach the pedals and increase the distance from the steering wheel.

For detailed information on how to adjust the driver's seat, see ⇒ *page 72*.

#### ⚠ WARNING

Improper use of steering wheel adjustment and improper seating position can cause serious personal injury.

- Adjust the steering wheel column only when the vehicle is not moving to prevent loss of vehicle control.
- Adjust the driver's seat or steering wheel so that there is a minimum of 10 inches (25 cm) between your chest and the steering wheel ⇒ *page 166, fig. 195*. If

you cannot maintain this minimum distance, the airbag system cannot protect you properly.

- If physical limitations prevent you from sitting 10 inches (25 cm) or more from the steering wheel, check with your authorized Audi dealer to see if adaptive equipment is available.
- If the steering wheel is aligned with your face, the supplemental driver's airbag cannot provide as much protection in an accident. Always make sure that the steering wheel is aligned with your chest.
- Always hold the steering wheel with your hands at the 9 o'clock and 3 o'clock positions to reduce the risk of personal injury if the driver's airbag deploys.
- Never hold the steering wheel at the 12 o'clock position or with your hands inside the steering wheel rim or on the steering wheel hub. Holding the steering wheel the wrong way can cause serious injuries to the hands, arms and head if the driver's airbag deploys.

#### Electrically adjustable steering wheel

Applies to vehicles: with electrically adjustable steering wheel

*The height and reach of the steering wheel can be electrically adjusted to suit the driver.*

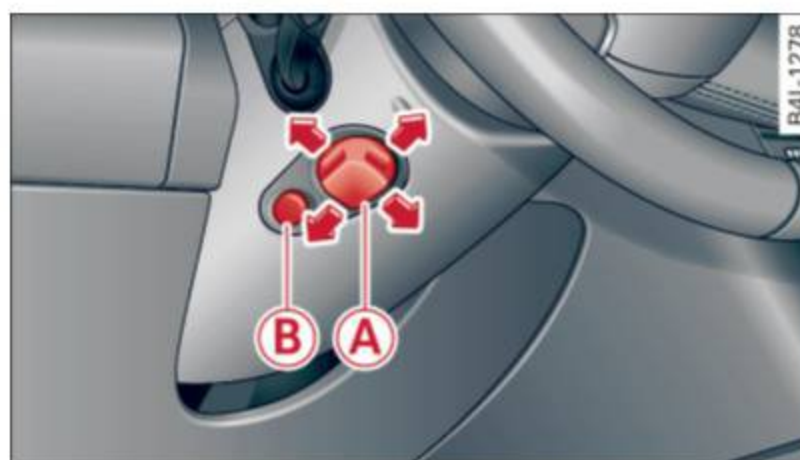

Fig. 118 Switch for steering wheel adjustment

First, adjust the driver's seat correctly.

#### Height adjustment

- ▶ Push the switch Ⓐ up or down ⇒ *fig. 118*. The steering wheel height changes for as long as you press the switch.

## Reach adjustment

- ▶ Push the switch **(A)** forward or backward ⇒ *fig. 118*. The steering wheel reach changes for as long as you press the switch.

There must be at least 10 inches (25 cm) between your chest and the center of the steering wheel. If you cannot sit more than 10 inches (25 cm) from the steering wheel, see if adaptive equipment is available to help you reach the pedals and increase the distance from the steering wheel.

For detailed information on how to adjust the driver's seat, see ⇒ *page 72*.

The steering wheel can be adjusted even when the ignition is turned Off. For vehicles with seat memory, the individual positions for the steering wheel can be stored along with the seat position.



### WARNING

Improper use of steering wheel adjustment and improper seating position can cause serious personal injury.

- Adjust the steering wheel column only when the vehicle is not moving to prevent loss of vehicle control.
- Adjust the driver's seat or steering wheel so that there is a minimum of 10 inches (25 cm) between your chest and the steering wheel ⇒ *page 166, fig. 195*. If you cannot maintain this minimum distance, the airbag system cannot protect you properly.
- If physical limitations prevent you from sitting 10 inches (25 cm) or more from the steering wheel, check with your authorized Audi dealer to see if adaptive equipment is available.
- If the steering wheel is aligned with your face, the supplemental driver's airbag cannot provide as much protection in an accident. Always make sure that the steering wheel is aligned with your chest.
- Always hold the steering wheel with your hands at the 9 o'clock and 3 o'clock posi-

tions to reduce the risk of personal injury if the driver's airbag deploys.

- Never hold the steering wheel at the 12 o'clock position or with your hands inside the steering wheel rim or on the steering wheel hub. Holding the steering wheel the wrong way can cause serious injuries to the hands, arms and head if the driver's airbag deploys.

## Easy entry feature

*The easy entry feature makes it easier to enter and exit the vehicle by automatically adjusting the steering wheel.*

Press the button **(B)** ⇒ *page 103, fig. 118* to turn the easy entry feature on or off.

When the easy entry feature is turned on (button depressed), the steering wheel moves up to the parked position when the ignition is turned off. After you enter the vehicle, the steering wheel moves to the stored position as soon as you turn on the ignition.

### Easy entry feature on vehicles with memory seat\*

For the stored steering wheel position to be recalled, the driver's seat memory must be switched on (**ON/OFF** switch in depressed position).

If the easy entry feature is switched off, the steering wheel moves to the stored position as soon as you press the seat memory button.

## Ignition lock and ignition switch

### Ignition key positions

The engine can be started or turned off with the ignition key.



Fig. 119 Ignition switch positions

#### Position 0

The ignition key can be inserted into the ignition switch in this position. This automatically unlocks the steering column lock. When the ignition key is removed, the steering column lock is automatically locked ⇒ ⚠.

#### Switching the ignition on/preheating 1

Turn the ignition key to this position and release it. On vehicles with a diesel engine\*, the system can preheat in this position.

#### Starting the engine 2

The engine starts with the key in this position. Major electrical loads are temporarily turned off.

#### Ignition off 0





Turn the ignition key to this position and release it.

#### ⚠ WARNING

- Never remove the key from the ignition lock while the vehicle is moving. The steering wheel will lock, causing loss of control.
- If you have to leave your vehicle, even for just a minute, always remove the ignition key and take it with you. This is especially important if you are going to leave chil-

dren unattended in the vehicle. The children could start the engine or use other vehicle controls. Unsupervised use of vehicle controls (for example, power windows) can cause serious personal injuries.

#### ! Note

- If the  symbol in the display blinks, there is a malfunction in the electronic steering column lock. Follow the instructions in ⇒ page 33,  *Steering malfunction*.
- If the  symbol in the display blinks, there is a malfunction in the electronic ignition lock. Follow the instructions in ⇒ page 34,  *Ignition lock malfunction*.

#### i Tips

- If you release the ignition key in position 2, the key automatically returns to position 1.
- If you open the driver's door when the ignition is switched on, a buzzer sounds and the message **Ignition is on** appears in the instrument cluster display. Please switch the ignition off.
- To prevent malfunctions in the ignition lock, remove any dirt or deposits from the key bit so that they do not enter the ignition lock.

### Ignition key safety lock

The ignition key can only be removed when the selector lever is in the "P" (Park) position.

After turning off the ignition, the ignition key can only be removed from the ignition lock when the selector lever is in the "P" (Park) position. After you have removed the key, the selector lever is locked and cannot be moved.

## Starting and stopping the engine

### Starting the engine

The engine can only be started with your original Audi key.





Fig. 120 Ignition key positions

#### Vehicles with gasoline engine:

- ▶ Step on the brake.
- ▶ Move the selector lever into P or N ⇒ ⚠.
- ▶ Turn the ignition key to position ② ⇒ *fig. 120* - do not depress the gas pedal when starting the engine.

#### Vehicles with diesel engine:

- ▶ Step on the brake.
- ▶ Move the selector lever into P or N ⇒ ⚠.
- ▶ Turn the ignition key to position ① - the glow plug indicator light  illuminates when the glow plug system is active.
- ▶ When the indicator light  switches off, turn the ignition key to position ② but do not press the accelerator pedal.
- ▶ Release the ignition key once the engine starts. The starter must not continue running.

A cold engine may sound loud after it has been started. This is due to the hydraulic valves building up oil pressure. This is normal and is not a need for concern.

If the engine does not start immediately, stop trying after 10 seconds and then try to restart the engine about 30 seconds later.

#### Glow plug system\*

**Diesel engines** are equipped with a glow plug system whose preheating time is controlled

by the coolant and outside temperature. Start the engine *immediately* after the glow plug indicator light  switches off.

The glow plug indicator light will only illuminate for approximately 1 second when the engine is warm or the outside temperature is higher than 46 °F (8 °C). That means you can start the engine *immediately*.

#### ⚠ WARNING

Never start or let the engine run in a confined or enclosed area. Exhaust fumes from the engine contain carbon monoxide, a colorless and odorless gas. Carbon monoxide can be fatal if inhaled.

- Never leave the engine idling unattended. An unattended vehicle with a running engine poses a danger of personal injury or theft.

#### ! Note

- Avoid high engine speeds, fast acceleration or heavy engine loads while the engine is still cold. This could damage the engine.
- The engine cannot be started by pushing or towing the vehicle.

#### For the sake of the environment

To avoid unnecessary engine wear and to reduce exhaust emissions, do not let your vehicle stand and warm up. Be ready to drive off immediately after starting your vehicle. Maintain moderate speed until the engine is completely warm. Remember, the engine performs best at operating temperature.

### Stopping the engine

- ▶ Turn the ignition key to position ① ⇒ *page 106, fig. 120*.

#### ⚠ WARNING

- Never turn off the engine until the vehicle has come to a complete stop.

- The brake booster and servotronic only work when the engine is running. With the ignition turned off, you have to apply more force when steering or braking. Since you cannot steer and stop normally, this can lead to accidents and serious injuries.
- The radiator fan can continue to run for up to 10 minutes even after you have turned off the engine and removed the ignition key. The radiator fan can also turn on again if the engine coolant heats up because of intense sunlight or heat build-up in the engine compartment.

### ! Note

Do not stop the engine immediately after hard or extended driving. Keep the engine running for approximately two minutes to prevent excessive heat build-up.

## Starting and stopping the engine with Convenience key

### Starting the engine with the **START** button

Applies to vehicles: with Convenience key

*This button switches on the ignition and starts the engine.*



Fig. 121 Convenience key: ENGINE START button

The **START** button is provided with **two-stage operation** ⇒ *fig. 121*.



### Switching the ignition on

- ▶ Press the **START** button once to the **first** stage to switch on only the ignition.

### Gasoline engine: Starting the engine

- ▶ Step on the brake.
- ▶ Move the selector lever to the P or N position ⇒ .
- ▶ Press the **START** button to the **second** stage to start the engine.

### Diesel engine: Starting the engine

- ▶ Step on the brake.
- ▶ Move the selector lever to the P or N position ⇒ .
- ▶ Press the **START** button down to the **first** level to begin the preheating process. The glow plug indicator light  illuminates when the glow plug system is active.
- ▶ When the indicator light  switches off, press the **START** button down to the **second** level to start the engine.

After a cold engine is started, there may be a brief period of increased noise because oil pressure must first build up in the hydraulic valve adjusters. This is normal and not a cause for concern.

If the engine does not start immediately, stop trying after 10 seconds and then try to restart the engine about 30 seconds later.

### Glow plug system\*

**Diesel engines** are equipped with a glow plug system whose preheating time is controlled by the coolant and outside temperature. Start the engine *immediately* after the glow plug indicator light  switches off.

The glow plug indicator light will only illuminate for approximately 1 second when the engine is warm or the outside temperature is higher than 46 °F (8 °C). That means you can start the engine *immediately*.

### WARNING

Never allow the engine to run in confined spaces - danger of asphyxiation.

### ! Note

- Avoid high engine rpm, full throttle and heavy engine loads until the engine has

reached operating temperature - otherwise you risk engine damage.

- The engine cannot be started by pushing or towing the vehicle.



### For the sake of the environment

Do not allow the engine to warm up with the vehicle stationary. Start driving right away. In this way you avoid unnecessary emissions.



### Tips

If you open the driver's door when the ignition is switched on, a buzzer sounds and the message **Ignition is on** appears in the instrument cluster display. Please switch the ignition off.

## Switching engine off with the **STOP** button

Applies to vehicles: with Convenience key



Fig. 122 Convenience key: ENGINE STOP button

- ▶ Bring your vehicle to a complete stop.
- ▶ Move the selector lever to the P or N position.
- ▶ Press the **STOP** button ⇒ *fig. 122*.

Pressing the **STOP** button once switches off the engine and the ignition. If you press the **STOP** button again for more than 1 second, the steering is locked, provided that the selector lever is in the P position ⇒

### Emergency OFF function

If necessary, the engine can be switched off with the selector lever in the R, D or S positions. To do so, step on the brake pedal and

press and hold the **STOP** button (vehicle speed must be less than 6 mph / 10 km/h).



### WARNING

- Never turn off the engine until the vehicle has come to a complete stop.
- The brake booster and servotronic only work when the engine is running. With the ignition turned off, you have to apply more force when steering or braking. Since you cannot steer and stop normally, this can lead to accidents and serious injuries.
- For safety reasons, you should always park your vehicle with the selector lever in P. Otherwise, the vehicle could inadvertently roll away.
- After the engine has been switched off, the radiator fan can continue to run for up to 10 minutes - even with the ignition switched off. It can also switch on again after some time if the coolant temperature rises as the result of a heat buildup or if the engine is hot and the engine compartment is additionally heated by the sun's rays.



### Note

If the engine has been under heavy load for an extended period, heat builds up in the engine compartment after the engine is switched off - there is a risk of damaging the engine. Allow the engine to run at idle for about 2 minutes before switching it off.

## Driver messages in the instrument cluster display

Applies to vehicles: with Convenience key

*If a function is not present, a driver message appears.*

### No key identified

This message appears when the **START** button is pressed if there is no master key inside the vehicle or if the system does not recognize ►

it. For example, the master key cannot be recognized if it is covered by an object (e.g. aluminum brief case) which screens the radio signal. Electronic devices such as cell phones can also interfere with the radio signal.

### Press brake pedal to start engine

This message appears if you press the **START** button to start the engine and do not depress the brake pedal. The engine can only be started if the brake pedal is depressed.

### Engage N or P to start engine

This message appears when the engine is started if the selector lever for the automatic transmission is not in the P or N position. The engine can only be started with the selector in these positions.

### Key not in vehicle

This message appears along with the  symbol if the master key is removed from the vehicle with the engine running. It is intended to remind you (e.g. when changing drivers) not to continue the journey without the master key.

If the master key is no longer in the vehicle, you cannot switch off the ignition after stopping the engine and you also cannot start the engine again. Moreover, you cannot lock the vehicle from the outside with the key.

### Shift to P otherwise vehicle can roll away. Doors do not lock if you are not in P.

This message appears for safety reasons along with a warning buzzer if the selector lever for the automatic transmission is not in the P position when the ignition is switched off with the **STOP** button and the driver's door is opened. Move the selector lever to the P position, otherwise the vehicle is not secured against rolling away. You also cannot lock the vehicle using the locking button on the door handle or using the remote key.

### To engage steering lock, press and hold STOP button

This message appears for safety reasons if the engine and the ignition have been switched off by pressing the **STOP** button once, and then the driver's door is opened. In this instance, the steering is not locked. The steering is locked:

- If you press the **STOP** button again for more than 1 second.
- If you close the driver's door and lock your vehicle from the outside.

## Parking brake

### Operation

*The parking brake replaces the handbrake.*

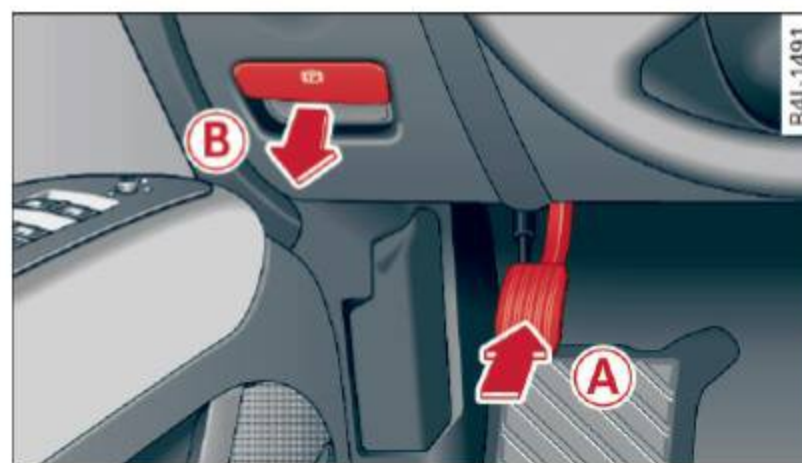



Fig. 123 Section of instrument cluster: Parking brake

### Applying parking brake

- ▶ Press the pedal down forcefully ⇒ *fig. 123* **A** in the direction of the arrow.



### Releasing parking brake

- ▶ Pull the handle to the rear **B** in the direction of the arrow ⇒ .

If you should drive off with the parking brake still set, a warning tone will sound and the following will appear in the instrument cluster to remind you to release the parking brake:

### Parking brake is applied

The parking brake warning comes on only after you have driven for longer than 3 seconds and faster than 5 mph (5 km/h).

The parking brake warning light  (USA)/  (CDN) illuminates when the parking brake is set and you switch on the ignition.

### WARNING

Always release the parking brake completely. A partially engaged brake will overheat the rear brakes, reduce their effectiveness and cause excessive wear. This could lead to brake failure and an accident.

### Note

Only after the vehicle has come to complete stop, should you firmly set the parking brake and move the selector lever into "P".

## Parking

### When you park your vehicle, do the following

- ▶ Stop the vehicle using the brake pedal.
- ▶ Apply the parking brake firmly.
- ▶ Move the selector lever into the **P** position .
- ▶ Switch off the engine and remove the ignition key from the ignition lock.

### When you park your vehicle on hills, do the following

- ▶ Stop the vehicle using the brake pedal.
- ▶ Apply the parking brake firmly.
- ▶ If you are parking headed **downhill**, turn the front wheels *toward* the curb.
- ▶ If you are parking headed **uphill**, turn the front wheels *away* from the curb.
- ▶ Move the selector lever into the **P** position.
- ▶ Switch off the engine and remove the ignition key from the ignition lock.

### WARNING

This is how you can reduce the risk of injury when leaving your vehicle.

- Never park the vehicle where it can come in contact with dry grass, spilled fuel or any other flammable materials.

- When parking on hills, always turn the wheels so that the front wheels will first roll into the curb, if the vehicle should start to roll.
- Never allow anyone - especially small children - to remain in the vehicle when it is locked. Locked doors make it more difficult for rescuers to access the passenger compartment in the event of an emergency. Danger to life!
- Never leave children unsupervised in the vehicle. Children could release the parking brake or move the gearshift lever out of gear. The vehicle could start to roll away and cause an accident.
- No matter what the season is, the temperature in a parked vehicle can reach dangerous levels.

### Note

- Please exercise care when you park your vehicle in parking areas with parking barriers or curbs. Parking barriers and curbs vary in height and could damage your bumper and related components as the front of your vehicle moves over a barrier or curb that is too high, as you park or as you back out of a parking spot. In order to be sure that no such damage can occur, you may wish to stop short of having the front tires of your car touch the parking barrier or curb.
- Please also exercise exceptional care when you drive up or down steep ramps or drive over curbs or other obstacles, for which the vehicle is not designed, because components of the vehicle close to the ground, such as bumper covers, spoilers and suspension and exhaust system components, may become damaged.

## Starting on hills

Hill Hold makes it easier to start on hills.

The system is activated when the brake pedal is depressed **for a few seconds**. For this, the 

vehicle must be standing in uphill driving direction.

After releasing the brake pedal, the brake power is held for a *brief moment* to prevent the vehicle from rolling back when starting. At this time, you can easily begin to move your vehicle.

### WARNING

- If you did not begin moving immediately after releasing the brake pedal, under certain circumstances, the vehicle would begin to roll backward. Depress the brake pedal immediately or engage the parking brake.
- Should the engine stall, depress the brake pedal immediately or engage the parking brake.
- In order to prevent the vehicle from rolling back unintentionally when starting in stop-and-go traffic, keep the brake pedal depressed for a few seconds before driving off.
- When you leave the vehicle - even if only briefly - , switch off the ignition and make sure to remove the ignition key. Also engage the **parking brake** to prevent your vehicle from rolling unintentionally. This particularly applies if children are left in the vehicle - danger of accident!

## Cruise control

### Switching the system on

The cruise control system makes it possible to drive at a constant speed starting at 20 mph (30 km/h).

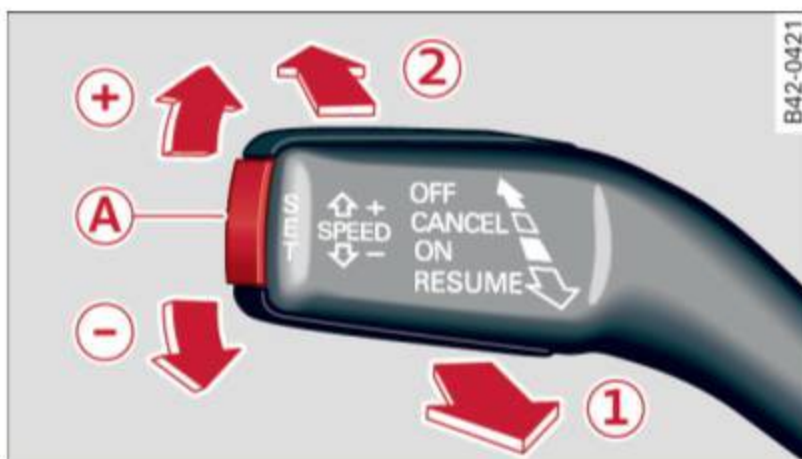



Fig. 124 Control lever with set button



Fig. 125 Display: Selected speed

- ▶ Pull the lever to position **1** ⇒ fig. 124 to switch the system on.
- ▶ Drive at the speed you wish to set.
- ▶ Press button **A** to set that speed.

The display ⇒ fig. 125 will show the set speed. The display may vary depending on the type of display in your vehicle. The indicator light **CRUISE** (US model) /  (Canadian model) will also light up in the instrument cluster.

### WARNING

- Always pay attention to traffic even when the cruise control is switched on. You are always responsible for your speed and the distance between your vehicle and other vehicles.
- For safety reasons, the cruise control should not be used in the city, in stop-and-go traffic, on twisting roads and when road conditions are poor (such as ice, fog, gravel, heavy rain and hydroplaning) - risk of accident.
- Turn off the cruise control temporarily when entering turn lanes, highway exit lanes or in construction zones.
- Please note that inadvertently “resting” your foot on the accelerator pedal causes the cruise control not to brake. This is because the cruise control is overridden by the driver’s acceleration.
- Never use the cruise control when driving off-road or on unpaved roads. The cruise control is intended for use only when the vehicle is being operated on paved roads, and is not suitable for use off-road or on unpaved roads.

**i Tips**

The cruise control cannot maintain a constant speed when driving downhill. The vehicle will accelerate under its own weight. Downshift to a lower gear or use the brakes to slow down.

**Changing speed**

- ▶ To increase/decrease the speed in increments, tap the lever in the **+**/**-** direction ⇒ *page 111, fig. 124.*
- ▶ To increase/decrease the speed quickly, hold the lever in the **+**/**-** direction until the desired speed is displayed.

You can also press the accelerator pedal down to increase your speed, e.g. if you want to pass someone. The speed you saved earlier will resume as soon as you release the accelerator pedal.

If, however, you exceed your saved speed by 5 mph (10 km/h) for longer than 5 minutes, the cruise control will turn off temporarily. The symbol will go out but the saved speed will be retained.

**Presetting your speed**

*You can preset your desired speed while the vehicle is not moving.*

- ▶ Turn on the ignition.
- ▶ Pull lever into position **1** ⇒ *page 111, fig. 124.*
- ▶ Press the lever in the **+** or **-** direction to increase or decrease your speed.
- ▶ Release the lever to save that speed.

This function makes it possible, for example, to save the speed you want before driving on the highway. Once on the highway, activate the cruise control by pulling the lever toward **1**.

**Switching the system off****Temporary deactivation**

- ▶ Press the brake pedal, or

- ▶ Press the lever into position **2** (not clicked into place) ⇒ *page 111, fig. 124,* or
- ▶ Drive for longer than 5 minutes at more than 5 mph (10 km/h) above the stored speed.

**Switching off completely**

- ▶ Press lever into position **2** (clicked into place), or
- ▶ Switch the ignition off.

The system retains the saved speed if you deactivate the cruise control temporarily. To resume the saved speed, release the brake pedal and pull the lever to position **1**.

Switching the ignition off erases the saved speed.

**! WARNING**

You should only return to the saved speed if it is not too fast for the current traffic conditions - risk of an accident!

## Adaptive cruise control

### Speed and distance control system

#### Description

Applies to vehicles: with adaptive cruise control

The adaptive cruise control driver assistance program is a combined speed and distance control system.



**Fig. 126** Front bumper: Position of radar sensor (not visible from outside)

Adaptive cruise control can help make driving more relaxed and less tiring, particularly during long trips on interstates or other highways that are generally straight. The system can also assist in stop and go traffic.

The adaptive cruise control works within a speed range between 0 and 95 mph (150 km/h). Set ACC to maintain a constant, legal travel speed between 20 and 95 mph (30 - 150 km/h) that is appropriate for prevailing traffic conditions. Select a following distance to the vehicle ahead and ACC will adjust your speed to maintain that distance down to a stop. At a speed below 20 mph (30 km/h), the minimum speed setting of 20 mph (30 km/h) will be selected automatically.

Adaptive cruise control has technical limitations that you must know, so please read this section carefully, understand how the system works and use it properly at all times.

#### How does it work?

You can operate the adaptive cruise control using the lever on the steering wheel column ⇒ page 116, *How is the speed stored?* and

⇒ page 118, *How is the distance (time interval) set?*

#### Driver information

Important information is brought up in the speedometer and in the instrument cluster display as the vehicle is being driven

⇒ page 120, *Driver information.*

#### What is important for you to know

The adaptive cruise control is set with system-specified limits; that is, as a driver, you will have to adjust the speed and distance to the vehicle ahead in some instances ⇒ page 124, *Driver intervention prompt* and ⇒ page 125, *System limitations.*

#### WARNING

Improper use of the adaptive cruise control can cause collisions, other accidents and serious personal injury.

- Always remember that the adaptive cruise control has limits – it will not slow the vehicle down or maintain the set distance when you drive towards an obstacle or something on or near the road that is not moving, such as vehicles stopped in a traffic jam, a stalled or disabled vehicle.
- Always remember that the adaptive cruise control cannot detect a vehicle that is driving towards you in your traffic lane and that it cannot detect narrow vehicles such as motorcycles and bicycles.
- Never drive at speeds that are too fast for traffic, road and weather conditions.
- Never follow a vehicle so closely that you cannot stop your vehicle safely. The adaptive cruise control cannot slow or brake the vehicle safely when you follow another vehicle too closely. Always remember that the adaptive cruise control has a braking power that is only about 30% of the vehicle's maximum braking ability. The automatic braking function cannot bring the vehicle to a sudden or emergency stop. Always be prepared to

- brake and take evasive action to avoid collisions and other accident situations.
- Never allow the closing speed between you and other vehicles to be so high that the adaptive cruise control may not be able to slow your vehicle safely. If closing speed is too high, you must apply the brakes yourself to reduce the risk of a rear-end crash.
  - Never rest your foot on the accelerator pedal, especially when the adaptive cruise control is being used. Pressure on the accelerator will override the ACC braking function and prevent the brakes from being applied when ACC detects a situation when the brakes must be applied.
  - Never use adaptive cruise control when you cannot drive safely at a steady speed, including on city streets, on winding roads or when road conditions are poor (for example, on ice, gravel, in fog, heavy rain or on wet roads that increase the risk of hydroplaning).
  - The radar sensor's *vision* can be reduced by rain, snow and heavy road spray. These and similar conditions can prevent vehicles up ahead from being accurately detected and in some cases they may not be detected at all. Do not use ACC when the radar sensors cannot accurately detect vehicles moving ahead of you in traffic.
  - Always turn off adaptive cruise control when entering turn lanes, exit lanes and construction zones or in similar situations because the vehicle will automatically accelerate to the stored speed when the road ahead is clear.
  - To prevent unintended operation, always switch ACC off when it is not being used.

### **i** Tips

- For safety reasons, the stored speed is deleted when the ignition is turned off.
- The Electronic Stabilization Control (ESC) and the Anti-Slip Regulation (ASR) cannot be deactivated when the adaptive

- cruise control is switched on. If the ESC and the Anti-Slip Regulation (ASR) has been deactivated and you then switch on the adaptive cruise control, the ESC function will also be activated automatically.
- Damage caused by accidents and some minor collisions can affect the radar sensor settings and cause the system to malfunction or switch off completely.
- The radar sensor cover is heated. In winter conditions, you should still check before driving to make sure it is free of ice and snow. If necessary, clean the area near the radar sensor carefully ⇒ *fig. 126*.
- To ensure that the radar sensor is not blocked, foreign objects (e.g. stickers, larger license plate mounts, add-on parts) must not cover the area near the radar sensor ⇒ *fig. 126*. The area near the radar sensor must not be painted, either.
- For Declaration of Compliance to United States FCC and Industry Canada regulations ⇒ *page 328*.

### How does adaptive cruise control work?

Applies to vehicles: with adaptive cruise control

*Vehicles traveling ahead are detected with the aid of a radar sensor.*

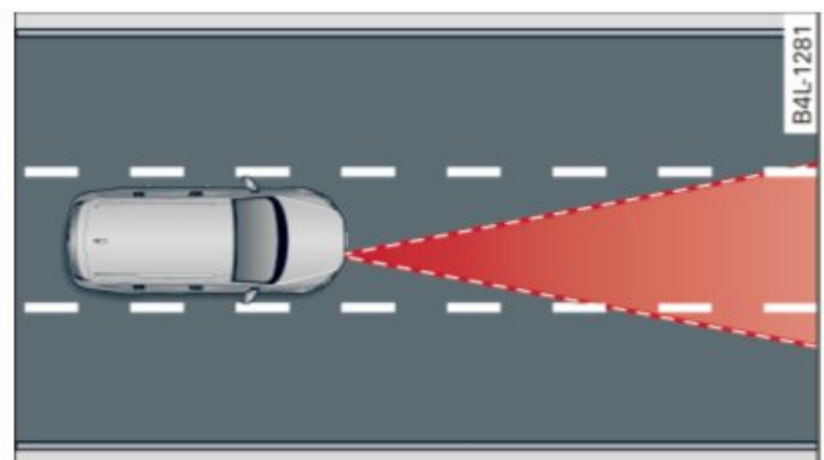

**Fig. 127** Basic principle diagram: Radar sensor measurement range

Adaptive cruise control uses a radar sensor in the front of the vehicle ⇒ *fig. 127*. The system has limitations ⇒ *page 125*. Things that are not moving in your lane and in your direction of travel will not be detected. The sensor measures the distance to reflective surfaces ▶

that must have a certain size. The system responds only after the distance measurement has been made. If a measurement is not possible, the system cannot respond and will not react to a vehicle or something else up ahead.

### Open road

When the road is clear, the adaptive cruise control works like cruise control. It maintains a constant target speed specified by the driver.

### Driving in traffic

If a slower vehicle driving ahead is detected, the adaptive cruise control decelerates (within the limits of the system) ⇒ *page 124, Driver intervention prompt* and ⇒ *page 125, System limitations* to its speed and after adjusting, tries to maintain the set distance from the vehicle ahead. The vehicle may temporarily drive slower than the set speed while adjusting ⇒  *in Description on page 113*.

If the vehicle in front accelerates, adaptive cruise control also accelerates up to the speed that you have set.

If the vehicle ahead slows to a stop, ACC will slow your vehicle down and to a complete stop if this is possible within the system's limits and capabilities. ACC will not make an emergency stop. The text message **ACC off: manual control!** appears in the instrument cluster display. Once the vehicle stops, you must depress the brake pedal to prevent the vehicle from moving forward or "creeping". Depressing the brake pedal turns off ACC. When the vehicle ahead accelerates you can reactivate ACC ⇒ *page 118*, as soon as your vehicle has reached a speed of 1 mph (2 km/h).

### Situations requiring driver intervention

In some situations you will have to use the footbrake to slow the vehicle down in order to keep a safe distance from vehicle in front of you or to avoid a rear-end collision. In this situation, a symbol appears and a warning tone sounds ⇒ *page 124*.

### Passing another vehicle

If you move into the passing lane and no vehicle is detected ahead, the adaptive cruise control accelerates to the speed you have set and maintains it.

### Overriding ACC

You can increase your speed at any time by stepping on the accelerator pedal. After you release the accelerator pedal, the system adjusts back down to the speed you previously set.

### Reducing stopping distance

If the radar sensor detects that the distance to the vehicle ahead is less than defined minimum distance, the brakes are automatically prepared for emergency braking by the driver. The brake pads are moved very close to the brake discs without actually braking the vehicle. This brake assistant feature reacts more quickly to the driver's braking, and also works when adaptive cruise control is off. The stopping distance is reduced as a result of this advance brake preparation. This function does not perform any emergency braking maneuvers by itself; the driver must always apply the brakes.

#### **WARNING**

If ACC initiates a braking maneuver, the brake pedal will be retracted. Interference with the brake pedal can prevent ACC from slowing the vehicle down and cause a crash and serious personal injury.

- Never put anything in the driver's footwell or let anything fall into it. An object in the driver's footwell can interfere with the pedals and prevent the accelerator from being used to override ACC or prevent ACC from being switched off when the brake pedal is depressed and also prevent the vehicle from being slowed down or stopped.
- Only use floor mats that keep the area around the pedals free and that can be securely fastened to the footwell.

- Never drive with your foot underneath the brake pedal.
- Always read and heed the information and WARNINGS ⇒ ⚠ in *Description on page 113*.

### ⚠ WARNING

- Never rely on the distance control feature of ACC alone to prevent rear-end collisions. Always be prepared to brake and take evasive action to avoid collisions and other accident situations.
- Never allow the closing speed between you and other vehicles to be so high that the adaptive cruise control may not be able to slow your vehicle safely. If closing speed is too high, you must apply the brakes yourself to reduce the risk of a rear-end crash.

### i Tips

Please note that the amount of acceleration the adaptive cruise control uses depends on the Distance setting selected. DISTANCE 1 gives you acceleration that is dynamic and sporty. DISTANCE 4, on the other hand, gives more moderate acceleration. For more information about the time intervals ⇒ *page 118, How is the distance (time interval) set?*

- Please note that if the adaptive cruise control has begun braking the vehicle and the driver chooses to brake the vehicle additionally, the brakes may feel “hard”. This is simply due to the pressure build-up of the initial braking.
- Adaptive cruise control is switched off after pressing the footbrake. The speed saved up to this point can be resumed. To resume the saved speed, release the brake pedal and pull the control lever toward you ⇒ *page 118, Turning adaptive cruise control off temporarily*.

### Switching the system on and off

Applies to vehicles: with adaptive cruise control

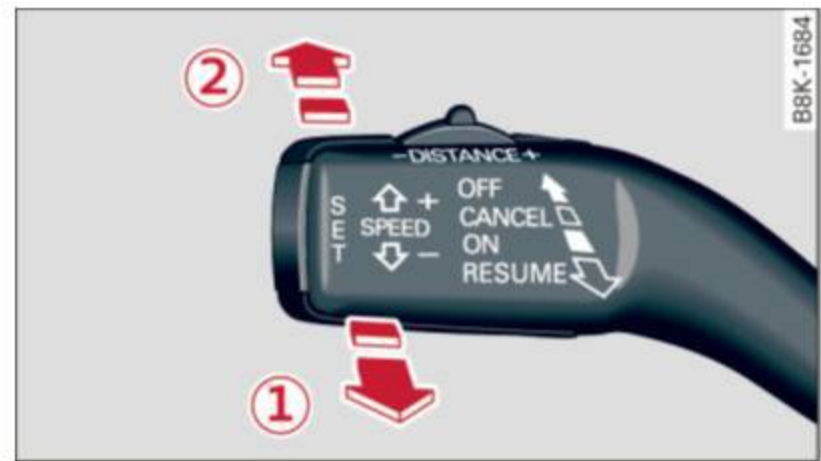

Fig. 128 Control lever: Switching on and off

### Switching the system on

- ▶ Pull the lever to position ① ⇒ *fig. 128*.

### Switching the system off

- ▶ Press the lever to position ② (latched).

### How is the speed stored?

Applies to vehicles: with adaptive cruise control



Fig. 129 Control lever: Storing speed

With **the system switched on** the speed is stored as follows:

- ▶ Drive at the speed you want.
- ▶ Press the **SET** button ⇒ *fig. 129* to store the desired speed.

After the **SET** button is released, the current speed is stored and maintained. If you are driving at a speed below 20 mph (30 km/h), the minimum speed setting of 20 mph (30 km/h) will be set.

The saved speed is now shown in the LED display in the speedometer by one or two illuminated red light diodes ⇒ *page 121*. At the same time, the saved speed is also shown for ▶

a short time in the Information line  
⇒ page 122.

### **i** Tips

For safety reasons, the stored speed is erased when the ignition or the ACC is turned off.

## Changing stored speed

Applies to vehicles: with adaptive cruise control

*The speed can be changed without touching the accelerator or brake pedal.*



Fig. 130 Control lever: Changing speed

### Increasing speed

- ▶ Press the lever **briefly** upwards (+) ⇒ fig. 130. USA models: the speed increases by about 2.5 mph. Canada models: speed will increase by one mark on the speedometer scale.
- ▶ Press the lever upwards (+) and **hold** it. As long as you hold the control switch down, the light diode display in the speedometer LED display in the speedometer moves forward and the speed is increased.

### Reducing speed

- ▶ Press the lever **briefly** downwards (-). USA models: the speed decreases by 2.5 mph. Canada models: speed will decrease by one mark on the speedometer scale.
- ▶ Press the lever downwards (-) and **hold** it. As long as you hold the control switch down, the light diode display in the speedometer LED display moves backward and the speed is reduced.

After releasing the control switch, the system regulates the speed to the value just set.

After each adjustment, the newly-set speed is shown for a short time in the Information line  
⇒ page 122.

### **!** WARNING

Improper use of the adaptive cruise control features and inattention can lead to an accident causing serious personal injury.

- It is dangerous to use the “RESUME” feature when the previously set speed is too high for existing road, traffic or weather conditions.
- Always read and heed the information and WARNINGS ⇒ **!** in Description on page 113.

### **i** Tips

You can increase your speed at any time by stepping on the accelerator pedal. After you release the accelerator pedal, the system adjusts back down to the speed you previously set. A new desired speed can be stored at any time by pressing the **SET** button ⇒ page 116, fig. 129.

### Turning adaptive cruise control off temporarily

Applies to vehicles: with adaptive cruise control

*In some situations it makes sense to turn adaptive cruise control off temporarily.*



Fig. 131 Control lever: Turning adaptive cruise control off temporarily



Fig. 132 Display in the speedometer

### Turning control off temporarily

- ▶ To shut off the control with the save function, either depress the brake pedal, or
- ▶ Press the lever in the direction of the arrow ② ⇒ fig. 131.

### How is the distance (time interval) set?

Applies to vehicles: with adaptive cruise control

*Distance can be set in four stages.*



Fig. 133 Control lever: Setting distance

### Reactivating control

- ▶ To resume the speed and distance control, release the brake pedal and press the lever in the direction of the arrow ①.

### Display in the speedometer

- Ⓐ Current vehicle speed ⇒ fig. 132
- Ⓑ Saved speed

As long as a speed is saved the set desired speed will be displayed in the LED display in the speedometer by one or two illuminated red light diodes. When the control function is resumed the adaptive cruise control accelerates to reach the desired speed if no slower vehicle ahead is detected.

### ⚠ WARNING

Improper use of the adaptive cruise control can cause collisions, other accidents and serious personal injuries.

- Never resume the stored speed if the speed is too high for prevailing road, traffic or weather conditions.



### ⓘ Tips

When the system is turned off temporarily, the speed set at that time is stored.

### Increasing distance

- ▶ Push the slider switch **once** to the right ⊕ ⇒ fig. 133. The distance currently set is shown for 3 seconds in the instrument cluster display.
- ▶ Push the slider switch **again** to the right ⊕ to increase the distance by one step. ▶

### Reducing distance









- ▶ Push the slider switch **once** to the left . The distance currently set is shown for 3 seconds in the instrument cluster display.
- ▶ Push the slider switch **again** to the left  to decrease the distance by one step.

The distance at which the adaptive cruise control follows a vehicle in front is determined by *time* intervals. A time interval to a vehicle in front is established and maintained. This produces a speed-dependent interval. The higher the speed, the greater the safety interval in feet (meters) ⇨ .

For example, if the interval **DISTANCE 3** is set, a vehicle in front is followed at a *time interval* of 1.8 seconds.









For a speed of **50 mph (80 km/h)** this would be equivalent to a distance of **131 feet (40 meters)** to the vehicle in front.

The distances given here are nominal values. The vehicle speed may exceed or fall short of these target speeds, depending on the driving situation and the driving style of the vehicle ahead.

|                               | DISTANCE 1  | DISTANCE 2  | DISTANCE 3  | DISTANCE 4  |
|-------------------------------|---|---|---|---|
| Symbol                        |   |   |   |   |
| Time interval                 | 1 second  | 1.3 seconds   | 1.8 seconds   | 2.3 seconds   |
| Dynamics                      | Sporting  | Standard  | Standard  | Comfortable   |
| Distance at 25 mph (40 km/h)  | 36 Feet (11 Meters)   | 46 Feet (14 Meters)   | 66 Feet (20 Meters)   | 82 Feet (25 Meters)   |
| Distance at 50 mph (80 km/h)  | 72 Feet (22 Meters)   | 95 Feet (29 Meters)   | 131 Feet (40 Meters)  | 167 Feet (51 Meters)  |
| Distance at 75 mph (120 km/h) | 108 Feet (33 Meters)  | 144 Feet (44 Meters)  | 197 Feet (60 Meters)  | 249 Feet (76 Meters)  |

How your vehicle responds when accelerating and following other vehicles with ACC operating can be adapted to your personal wishes through different driving programs. Depending on which driving program and which dis-

tance you choose, your vehicle will respond more dynamically or more comfortably when accelerating and braking. The setting is selected through the MMI menu **adaptive cruise control** ⇨ *page 124, MMI settings*.

| Settings                               | DISTANCE 1  | DISTANCE 2  | DISTANCE 3  | DISTANCE 4  |
|--|---|---|---|---|
| Symbol for time interval               |   |   |   |   |
| Support for:                           | Bumper-to-bumper traffic, brisk driving   | Bumper-to-bumper traffic, "keeping pace" comfortably  | Bumper-to-bumper traffic, "keeping pace" comfortably  | Secondary roads, trailer operation  |
| Response in "dynamic" driving program  | 1   | 2   | 2   | 3   |
| Response in "standard" driving program | 2   | 3   | 3   | 4   |
| Response in "comfort" driving program  | 3   | 4   | 4   | 5   |

(dynamic) 1 ----- 2 ----- 3 ----- 4 ----- 5 (comfortable) ▶

**! WARNING**

Following other vehicles too closely increases the risk of a crash and serious personal injury.

- Following other vehicles too closely, particularly at higher speeds increases the risk of collisions and serious personal injury.
- Setting short distances to the traffic ahead reduces the time and distance available to bring your vehicle to a safe stop and makes it even more necessary to pay close attention to traffic.
- Always select a speed and distance to traffic ahead that is safe and appropriate under the prevailing traffic, road, weather and lighting conditions.
- Never rely on the distance control feature of ACC alone to prevent rear-end collisions. Always be prepared to brake and take evasive action to avoid collisions and other accident situations.
- Never allow the closing speed between you and other vehicles to be so high that the adaptive cruise control may not be able to slow your vehicle safely. If closing speed is too high, you must apply the brakes yourself to reduce the risk of a rear-end crash.
- Always select a greater following distance to the vehicle ahead on wet roads than on dry roads.
- Always read and heed the information and WARNINGS ⇒ **!** in Description on page 113.

**i Tips**

The distance setting is reset to the factory default **DISTANCE 3** the next time the ignition is turned on.

**Driver information****Displays in the instrument cluster**

Applies to vehicles: with adaptive cruise control

Depending on the driving situation, driver information is displayed in the instrument cluster.



Fig. 134 Overview instrument cluster

- A** Speedometer and indicator light display
- B** Display in the instrument cluster

**A Speedometer and indicator light display**

Important information concerning vehicle operation with adaptive cruise control is shown in display area **A**. The desired speed you set is indicated in the speedometer (LED lights around the edge).

The indicator lights show whether the system has detected a vehicle traveling ahead.

**B Display in the instrument cluster**

In display area **B** information from the navigation system\* and the trip computer is displayed in addition to information about adaptive cruise control.

You can select among the different information by repeated brief taps on the **RESET** button on the windshield wiper lever ⇒ page 25, Operation.

Certain pieces of information in the bottom part of the display are not shown permanently. Information is displayed only if you set or change the speed setting, change the time interval, when messages are displayed or if the adaptive cruise control is turned off for safety reasons.

## Display in the speedometer

Applies to vehicles: with adaptive cruise control



Fig. 135 Display in the speedometer







### Desired speed

The desired speed set by the driver is displayed by a red LED.

If the desired speed was set between two lines on the speedometer using the **SET** button, the two closest light emitting diodes will come on ⇒ *fig. 135*.

The system allows only speeds to be set between 20 to 95 mph (30 to 150 km/h) to be set. This speed range is faintly illuminated in the speedometer (LED lights).

### Indicator lights (symbols)

-  **Open road:** The indicator light  shows that ACC is active and that no moving vehicle has been detected within range of the radar sensor up ahead in your lane of travel. The set speed is maintained.
-  **Driving in traffic:** The indicator light  shows that a vehicle moving in your lane of travel has been detected up front in your lane of travel. Your speed is adjusted according to the speed of the vehicle up front. ACC accelerates and brakes automatically within the system's capabilities.
-  **Driver intervention prompt:** The red flashing warning light  means **Request for driver to assume control**. You as the driver must slow the vehicle with the foot brake. The symbol  tells you that the adaptive cruise control is not able to slow the vehicle down enough to keep a enough distance to the vehicle in front of you. A warning tone will also sound when

the symbol appears. For more information about the driver intervention prompt ⇒ *page 124*.

### WARNING

Improper use of the adaptive cruise control features and inattention can lead to a crash and serious personal injury.

- Never allow the closing speed between you and other vehicles to be so high that the adaptive cruise control may not be able to slow your vehicle safely. If closing speed is too high, you must apply the brakes yourself to reduce the risk of a rear-end crash.
- Always select a greater following distance to the vehicle up ahead on wet roads than on dry roads.
- Always read and heed the information and WARNINGS ⇒  in Description on page 113.

### Tips

- If you use the accelerator to go faster than the speed of the vehicle ahead of you, the driver intervention prompt will not be accompanied by a warning tone.
- If the speed you previously set is exceeded, the indicator light in the speedometer will switch off.

## Display in the instrument cluster

Applies to vehicles: with adaptive cruise control

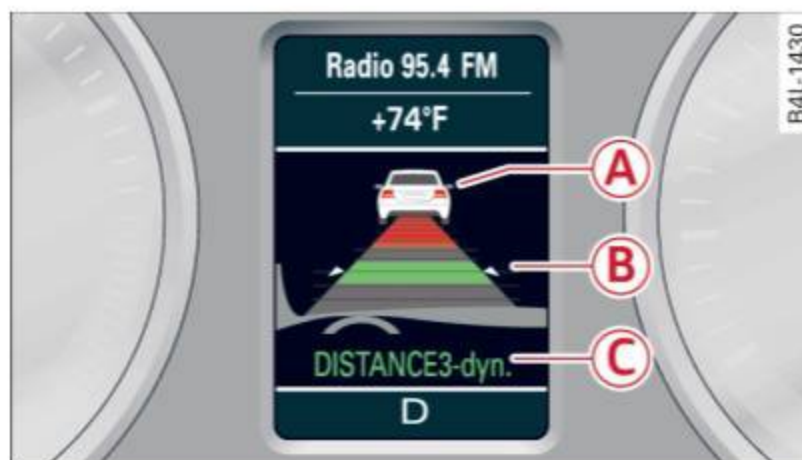

Fig. 136 Display in the instrument cluster

Scroll through the available information displays by briefly tapping the **RESET** button at the end of the windshield wiper lever. You can ▶

select information from the trip computer, navigation system\* or adaptive cruise control.

- Ⓐ Vehicle symbol
- Ⓑ Distance
- Ⓒ Status

### Ⓐ Vehicle symbol

The vehicle symbol indicates whether the system has detected an object traveling in front.

- **Vehicle outline:** Open road, no vehicle ahead.
- **White vehicle:** A vehicle is detected ahead.
- **Red vehicle:** Request for driver to assume control.

### Ⓑ Distance

Using the arrows and scale, you can detect how far it is to the vehicle in front of you.

- **Open road:** No arrow appears when the vehicle is on an open road and there is no vehicle ahead.
- **Driving in traffic:** If a vehicle is detected ahead, the arrow moves on the scale. The green area represents the distance set. When approaching slowly, the arrow moves from the **gray** zone to the **green** zone on the scale.
- **Driver intervention prompt:** When approaching rapidly, the arrow serves as an early warning signal. If the distance selected is exceeded or possibly not reached, the arrow moves into the **red** zone on the scale. In certain driving situations, you as the driver will have to take action ⇒ *page 124, Driver intervention prompt.*

### Ⓒ Status

- The text **ACC: Off** appears in white letters when adaptive cruise control is turned off.
- The text **ACC: Standby** appears in white letters when the system is turned on but no desired speed has been set.
- The text **ACC: override** appears in white letters when you exceed the desired speed by accelerating.

- The text **DISTANCE!** appears in red letters when the interval to a vehicle traveling ahead is too short and you have to slow your vehicle additionally with the foot brake.
- The text messages **DISTANCE 1** to **DISTANCE 4** appear in green letters to indicate the time interval you have set and adaptive cruise control is in management mode.
- If the driving program “standard” is replaced by “comfort” or “dynamic” using the MMI, the above text message is supplemented by an appropriate prompt, e.g. **DISTANCE 1 - dyn..**

### System status indicator

Applies to vehicles: with adaptive cruise control

The text messages and symbols shown in this area of the display are not displayed permanently.

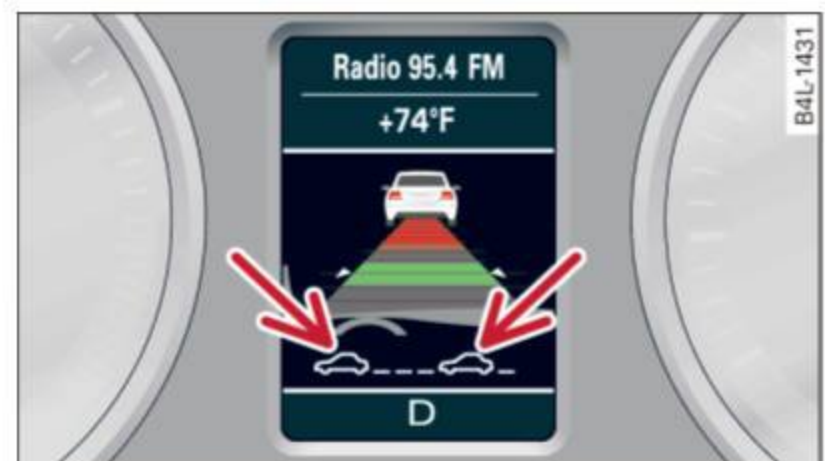

Fig. 137 System status indicator

### Time intervals (such as ☁-----☁)

The different symbols for the time intervals (distance) appear if you change the settings ⇒ *fig. 137.*

...

Three white dots ... appear if a setting cannot be made with the operating lever. The following are possible reasons

- If you pull the control lever towards you to resume speed but no requested speed was set.
- If you push the lever up to increase (or down to reduce) speed when no speed has been set previously.
- If you push the lever up to increase (or down to reduce) speed and this speed is outside

the 20 to 95 mph (30 to 150 km/h) speed range.

### **ACC: Unavailable**

The text message **ACC: Unavailable** appears, for example, if the temperature of the brakes is excessive. Adaptive cruise control is temporarily not available. A warning tone sounds as a reminder.

### **ACC: Not available**

The text message **ACC: Not available** appears in the event of a malfunction. Adaptive cruise control is turned off. A warning tone sounds as a reminder. Have the system inspected by a qualified dealership.

### **ACC: Sensor blocked**

The text message **ACC: Sensor blocked** appears when the ACC System can no longer accurately detect vehicles moving up ahead in your lane of travel. Adaptive cruise control is turned off. A warning tone also sounds as a reminder.

To decide whether it is necessary to switch off the ACC (ACC: Sensor blocked) or if it is only a temporary condition (ACC functionality limited) the system will take into consideration the outside temperature and/or the windshield operation.

The ACC sensor is dirty or blocked (e.g. leaves, snow).

The ACC sensor is located behind the area to the right of the front license plate. If the ACC sensor is dirty or blocked, clean the area to restore system operation.

### **ACC off: Manual control!**

The text message **ACC off: Manual control!** appears after the vehicle has been brought to a standstill by the adaptive cruise control. In this case you must depress the brake pedal to prevent the vehicle from rolling. A warning tone sounds as a reminder.

### **Stabilization control (ESC)**

The text message **Stabilization control (ESC)** appears if the Electronic Stabilization Control (ESC) has intervened. In this case the adaptive cruise control is automatically turned off. This is accompanied by a warning tone.

### **Speed**

The set speed in mph (Canada km/h) always appears when saving or changing the speed in adaptive cruise control ⇒ *page 116, How is the speed stored?* and ⇒ *page 117, Changing stored speed.*

### **ACC functionality limited**

The message **ACC functionality limited** appears when the ACC System does not detect any moving vehicles up ahead in your lane of travel for a longer period of time. During this time, the distance to moving vehicles in your lane of travel up ahead is not being maintained. The ACC system is not switched off, and increased attention to the traffic situation is absolutely necessary. The following may be reasons why the message **ACC functionality limited** appears:

- The ACC sensor is dirty. The ACC system is not reacting, or is not reacting correctly, to moving vehicles up ahead in your lane of travel.
- There may be very light traffic on and there is nothing that marks the side of the road (for example, guard rails, traffic signs, trees). As soon as a moving vehicle up ahead is detected again, ACC becomes active again and the message disappears.

The ACC sensor is located behind the area to the right of the front license plate. If the ACC sensor is dirty or blocked, clean the area to restore system operation.

### **Parking brake!**

The text message **Parking brake!** appears, when the parking brake is applied. ACC is turned off. A warning tone sounds as a reminder.

### Stationary object ahead

The text message **Stationary object ahead** appears, when you want to activate the system and there is a stationary vehicle or an object immediately in front of you.

### Gradient too steep

The text message **Gradient too steep** appears when the maximum gradient for proper ACC operation has been exceeded. Adaptive cruise control is turned off. A warning tone also sounds as a reminder.

### Shift lever position!

The text message **Shift lever position!** appears when the selector lever is moved to position **N**. In this position, adaptive cruise control is not available.

### Driver intervention prompt

Applies to vehicles: with adaptive cruise control

*The driver intervention prompt calls on the driver to take over the situation.*



Fig. 138 Instrument cluster: Driver intervention prompt

In certain situations, the braking power of the adaptive cruise control is not enough to maintain an adequate distance to the vehicle up ahead. In these situations, the adaptive cruise control calls the driver to take action.

The **driver intervention prompt** alerts you visually and audibly to take over.

- A red vehicle is shown in the instrument cluster display ⇒ *fig. 138*.
- The text **DISTANCE!** appears in the status line.

- The indicator light  in the speedometer blinks red.
- A warning tone sounds.

### Tips

- Adaptive cruise control is switched off after pressing the footbrake. The speed saved up to this point can be resumed.
- To resume the saved speed, release the brake pedal and press the control lever ⇒ *page 118, Turning adaptive cruise control off temporarily*.
- If you use the accelerator to go faster than the speed of the vehicle ahead of you, the **driver intervention prompt** will not be accompanied by a warning signal.
- If the speed you previously set is exceeded, the indicator light in the speedometer will switch off.

### MMI settings

Applies to vehicles: with adaptive cruise control

*Individual settings for adaptive cruise control can be selected in the MMI.*

Settings for the **Driving program** can be adjusted individually to the particular user and saved in the MMI. This can only be done with the engine running.

- ▶ Select: **CAR** function button > **Systems\*** control button > **adaptive cruise control** > **Driving program**. Or
- ▶ Select: **CAR** function button > **Car systems\*** control button > **Driver assist** > **Adaptive cruise control** > **Driving program**.

### Setting the driving program

In the **Driving program** menu you can adjust the characteristics of adaptive cruise control to your own preferences using **Dynamic**, **Standard** or **Comfort**.

### Saving settings

Your individual settings are automatically saved and assigned to the remote control key being used (remote key storage). If the key is ▶

given to another person, the saved settings remain as they are.

## System limitations

### General information

Applies to vehicles: with adaptive cruise control

*The radar sensor has limits that the driver must know to be able to use ACC properly.*

The adaptive cruise control works within limits that are also related to radar sensor range and sight distance. In some situations ACC may react unusually or late from the driver's point of view. Therefore, always be attentive to what is happening around you and always be ready to intervene, if necessary:

- when driving around curves ⇒ *page 125*
- when vehicles up front are not in line with your vehicle ⇒ *page 126*
- when other vehicles are changing lanes ⇒ *page 126*
- when other vehicles are difficult to detect ⇒ *page 126*
- when vehicles up ahead are not moving or obstacles are in your travel lane ⇒ *page 126*

### WARNING

The radar sensor's function and range can be reduced by rain, snow and heavy spray. Moving vehicles up ahead may not be promptly detected or may not be detected at all.

- Always pay careful attention to the traffic situation and be ready to intervene and be ready to take complete control whenever necessary.

### When driving around curves

Applies to vehicles: with adaptive cruise control

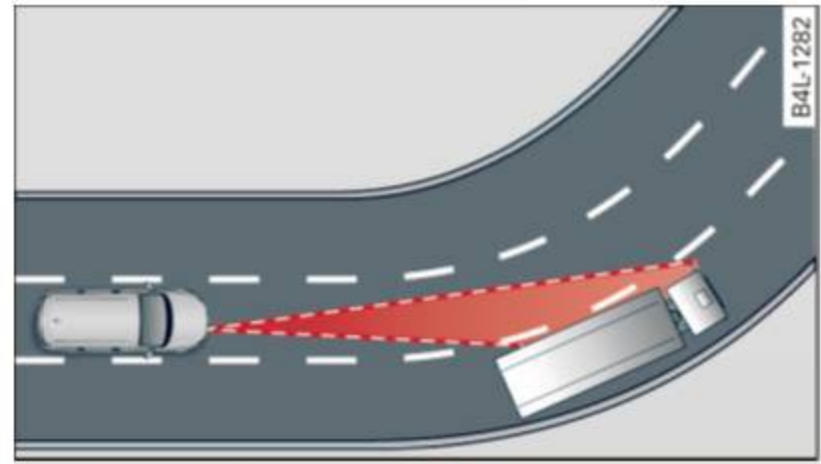

Fig. 139 Vehicle entering a curve

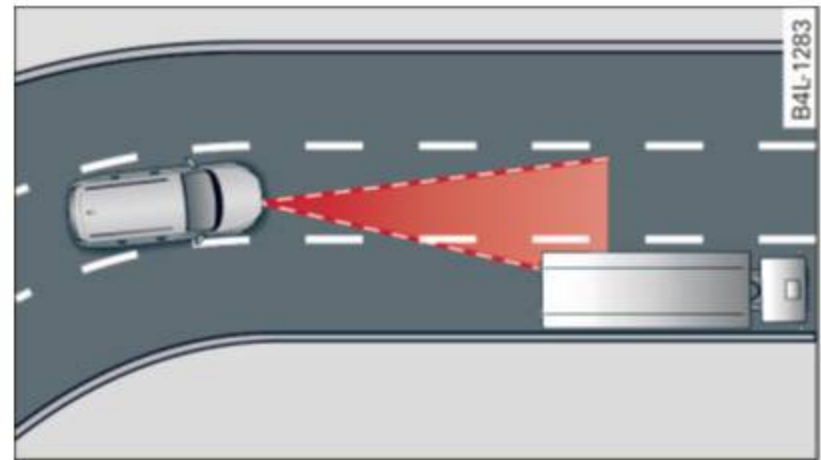

Fig. 140 Vehicle leaving a curve

### Entering a curve

When entering a curve, the adaptive cruise control may react to a vehicle in the next lane and apply the brakes in your vehicle ⇒ *fig. 139*. The braking action can be overridden by depressing the accelerator pedal.

### Leaving a curve

At the end of very long curves, ACC's predictive lane reading can cause ACC to react to another vehicle in the next lane and apply the brakes on your vehicle ⇒ *fig. 140*. The braking action can be overridden by depressing the accelerator pedal.

**Vehicles offset to one side**

Applies to vehicles: with adaptive cruise control

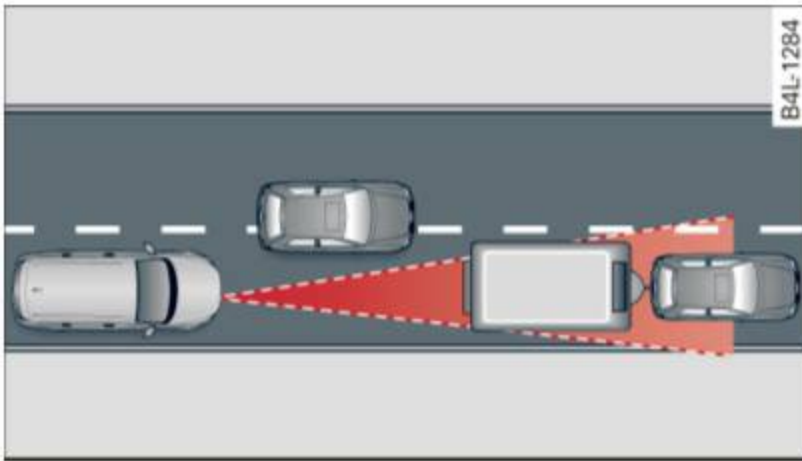
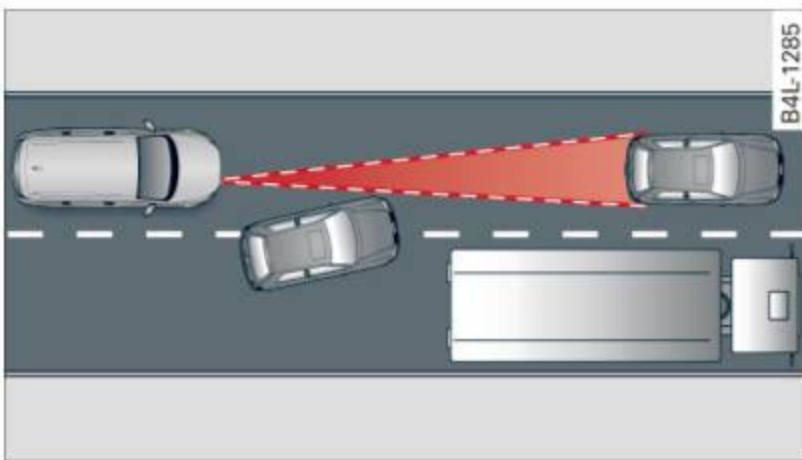

**Fig. 141** Vehicle traveling ahead outside the detection range of the radar sensor

Vehicles moving up ahead but offset in the lane cannot be detected by ACC until they are in sensor range.

**Lane changes by other vehicles**

Applies to vehicles: with adaptive cruise control

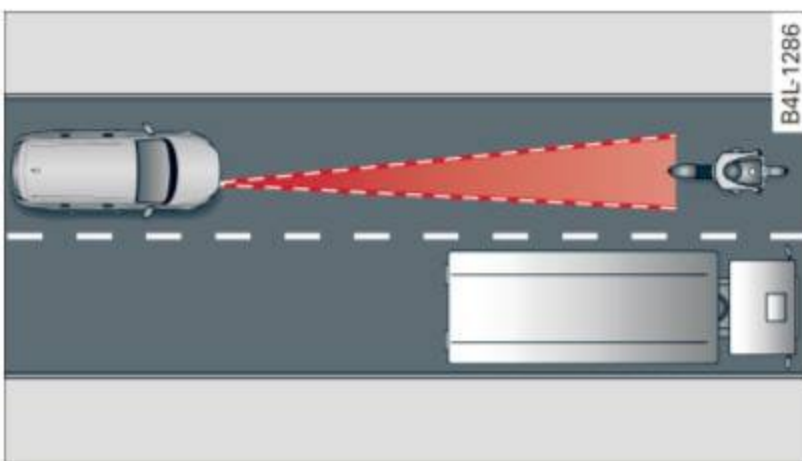

**Fig. 142** A vehicle changes lanes

Vehicles that cut into your lane a short distance in front of you cannot be detected by ACC until they are in sensor range.

**Vehicles that are difficult to detect**

Applies to vehicles: with adaptive cruise control

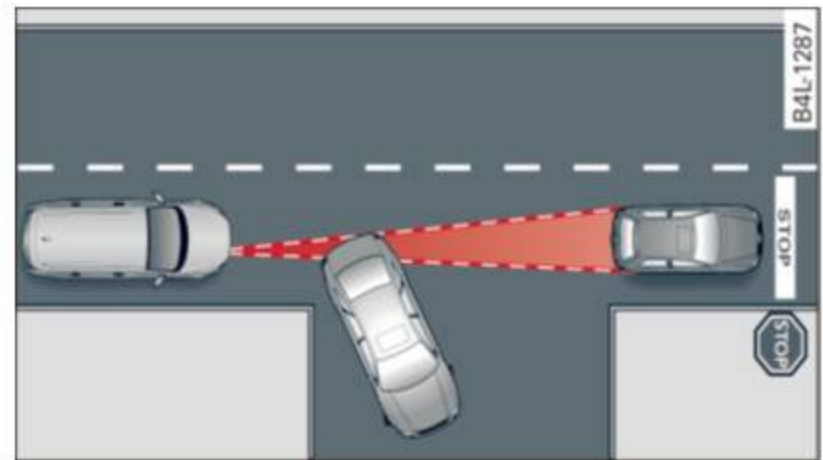

**Fig. 143** Two-wheeled vehicle driving ahead

Some vehicles moving up ahead in your lane of travel are difficult to detect, for example two-wheeled vehicles, vehicles with high ground clearance, loads sticking out the back. Vehicles like this are often detected late or in some situations not at all.

**Stationary vehicles**

Applies to vehicles: with adaptive cruise control



**Fig. 144** Turning and stationary vehicle

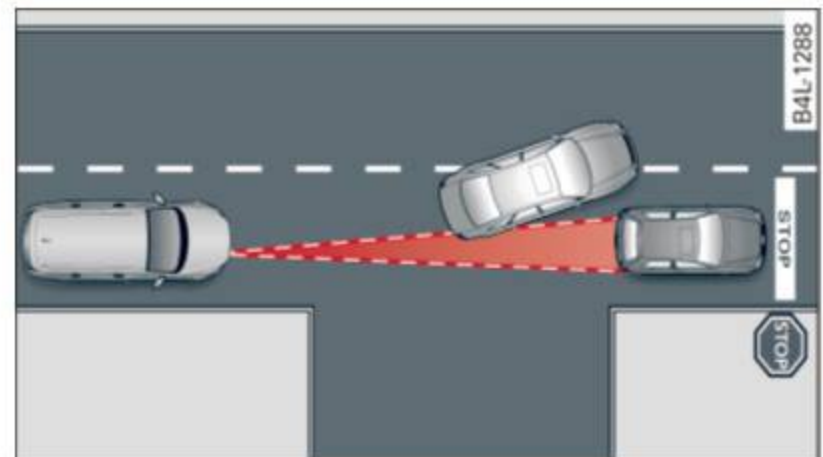

**Fig. 145** Sheering out and stationary vehicle

If a vehicle that has been detected by ACC exits the highway or sheers out into the neighboring travel lane, and there is a stationary vehicle ahead of that vehicle, ACC will not detect or react to that stationary vehicle ⇒ *fig. 144* and ⇒ *fig. 145*.

## Audi braking guard

### Description

Applies to vehicles: with adaptive cruise control

*Audi braking guard warns you of a possible collision with a moving vehicle up ahead.*



Fig. 146 Display in the instrument cluster

The Audi braking guard is active from a speed of approx. 20 mph (30 km/h) and works within the system limits ⇒ *page 125* even when the adaptive cruise control is deactivated.

A radar sensor is built into the front of the vehicle ⇒ *page 114, fig. 127*. The system is intended to measure the distance to reflective surfaces. If a measurement is not possible, the system does not respond.

When the measurement has been taken, the system can recognize a possibly hazardous situation, for example, when a vehicle up ahead in your lane of travel suddenly brakes or when your own vehicle is moving at high speed towards a much slower vehicle up ahead. As soon as the system senses that a possible collision with the vehicle up ahead can only be avoided by immediate full brake application or by an avoidance maneuver, a warning appears.

The system has a default response time to be able to signal before a collision occurs. This system response time is automatically reduced if you accelerate actively, for example to join a highway. Braking, transverse acceleration and the steering angle can lead to a reduced system response time. The warning is deactivated if you begin to overtake with full acceleration.

The system can make you aware of two different hazardous situations:

### Distance

The distance warning is given if the system calculates that there is not enough distance to the vehicle up ahead a period of more than 5 seconds. If the distance is less than 30 feet (9 meters) at 50 mph (80 km/h), for example, an optical display comes on in the instrument cluster ⇒ *fig. 146*.

If the vehicle ahead brakes sharply, Audi braking guard cannot help you to avoid a collision, even in the case of an immediate response. Take immediate action to avoid the collision and increase the distance to the vehicle up ahead.

### Speed

If there is a much slower vehicle moving up ahead in your lane, or if the vehicle ahead brakes sharply, the Audi braking guard calculates the point from which a collision can only be avoided by full braking or by an avoidance maneuver. If a warning does sound, a possible collision with the vehicle in front can only be avoided through an evasive maneuver or by braking.

The warning is given in two stages:

- **Pre-warning:** A visual display appears in the instrument cluster and a warning tone sounds.
- **Acute warning:** If you do not respond to the pre-warning, the second stage warning is given. A quick brake application helps to direct your attention to the road and traffic situation.

Under heavy braking, the brake assistant ⇒ *page 114* also helps you benefit from maximum braking efficiency.

### WARNING

Inattention can cause collisions, other accidents and serious personal injuries.

- Always pay close attention to the traffic, even when the Audi braking guard is switched on. The Audi braking guard provides a warning but does not brake the car for you. You must apply the brakes yourself!
- Always keep the safe and legal distance between your vehicle and vehicles up ahead.
- Audi braking guard works within limits and will not respond outside the system limits, for example when approaching a stopped vehicle or stationary obstacle (end of a traffic jam or vehicle that has broken down in traffic).
- Always remember that the radar sensor for the Audi braking guard works within defined detection and range limits that may prevent the proper detection of other vehicles.
- The radar sensor's function and range can be reduced by rain, snow and heavy spray. Moving vehicles up ahead may not be promptly detected or may not be detected at all.
- Always pay careful attention to the traffic situation and be ready to intervene and be ready to take complete control whenever necessary.
- Reflective surfaces including crash barriers or tunnel entrances may impair the function of the radar sensor.

### Settings in the MMI

Applies to vehicles: with adaptive cruise control

*The settings of the Audi braking guard are performed in the MMI.*

- ▶ Select: **CAR** function button > **Systems\*** control button > **Audi braking guard**. Or
- ▶ Select: **CAR** function button > **Car systems\*** control button > **Driver assist** > **Audi braking guard**.
- **System** - the Audi braking guard system can be switched **On** and **Off**.
- **Early warning** - the acoustic warning and the messages can be switched **On** and **Off**.

### Tips

When handing over the keys to another person, the previous settings are adopted if the Audi braking guard is activated  
⇒ page 43.

### Driver's information in the instrument cluster display

Applies to vehicles: with adaptive cruise control

#### Braking guard activated

This message appears when the Audi braking guard applies the brakes during a second stage (acute) warning.

#### Braking guard off

This message appears when the system has been deactivated via the MMI. This message also appears briefly at each beginning of a trip if the system is switched off.

This message also appears when the system is not available because of a malfunction or if ESC is switched to the Offroad mode ⇒ page 225. The system can no longer warn of an impending collision.

## Audi side assist

### Lane Change Assistant

#### Description

Applies to vehicles: with side assist

The side assist helps you when changing lanes.



Fig. 147 Rear bumper: Position of radar sensors (not visible on outside)



Fig. 148 Signal light on the outside mirror - driver's side

Side assist uses radar sensors (not visible on outside) ⇒ *fig. 147* to help the driver check blind spots, and see what is happening in traffic behind the vehicle ⇒ *page 130, fig. 150*.

Signal lights are built into both outside mirrors ⇒ *fig. 148*. The signal light on the left outside mirror assists when moving over into the left lane and the signal light on the right outside mirror assists when moving over into the right lane.

The signal light comes on to tell you that side assist has detected a vehicle on that side and that the position of this other vehicle should be taken into account if you were to change lanes. This is called the **informational stage signal** ⇒ *page 131*. The informational stage

signal is designed so that you notice it only when you are looking in the outside mirror.

When you activate the turn signal and side assist detects a vehicle in a notable location, the corresponding signal on the outside mirror flashes briefly and brightly several times. This is the **alert stage signal** ⇒ *page 131*.

#### Activating and deactivating

Applies to vehicles: with side assist



Fig. 149 Driver's door: Side assist button

#### Activating

- ▶ Press the ⇒ *fig. 149* button. The indicator on the button lights up.

#### Deactivating

- ▶ Press the button again. The indicator light on the button goes out.

The system works at speeds faster than 19 mph (30 km/h).

#### ! WARNING

- Improper reliance on the side assist system can cause collisions and serious personal injury:
  - Never rely only on side assist when changing lanes.
  - Always check rear view mirrors to make sure that it is safe to change lanes.
  - Side assist cannot detect all vehicles under all conditions- danger of accident!
  - Side assist cannot detect vehicles in time to alert you when they approach from behind at very high speed, or fall drop back very quickly.

- The radar sensor's *vision* can be reduced or entirely blocked by rain, snow, and heavy spray. This can result in side assist not adequately detecting vehicles or, in some cases, not detecting them at all. Always keep an eye on the direction you are traveling and the relevant area around the vehicle.
- Please note that side assist indicates there are approaching vehicles, or vehicles in your blind spot, only after your vehicle has reached a driving speed of at least 19 mph (30 km/h).
- Side assist signal does not work around tight corners (turning radius less than 328 feet, or 100 m).
- Side assist is no replacement for the driver's full attention. The driver alone is responsible for lane changes and similar driving maneuvers. Always keep an eye on the direction you are traveling and the relevant area around the vehicle.

### ! Note

- To ensure that you do not adversely affect side assist, do not block the area on the rear bumper where the radar sensors are located with foreign objects (such as stickers or bicycle racks).
- Make sure that the signal light on the outside mirror is not blocked by stickers or other items.

### i Tips

- Side assist automatically deactivates if it detects that the radar sensors are blocked ⇒ *page 135*. The indicator light on the button goes out.
- The area on the bumper where the radar sensors are located must consistently remain free of snow, ice, and heavy soiling so that side assist can function properly. Follow the additional notes on ⇒ *page 136*.
- For vehicles with a factory installed towing hitch\* or a trailer hitch\* that was installed later according to factory specifications, side assist is automatically deac-

tivated as soon as the electrical connection to the trailer electrical socket is made ⇒ *page 135*.

- For vehicles with a trailer hitch that was **not** installed according to factory specifications, switch off the side assist when towing a trailer.
- Additional tinting on the front side windows can make it harder to see and correctly understand the signal light on the outside mirror.
- For Declaration of Compliance to United States FCC and Industry Canada regulations ⇒ *page 328*.

### Sensor detection area

Applies to vehicles: with side assist

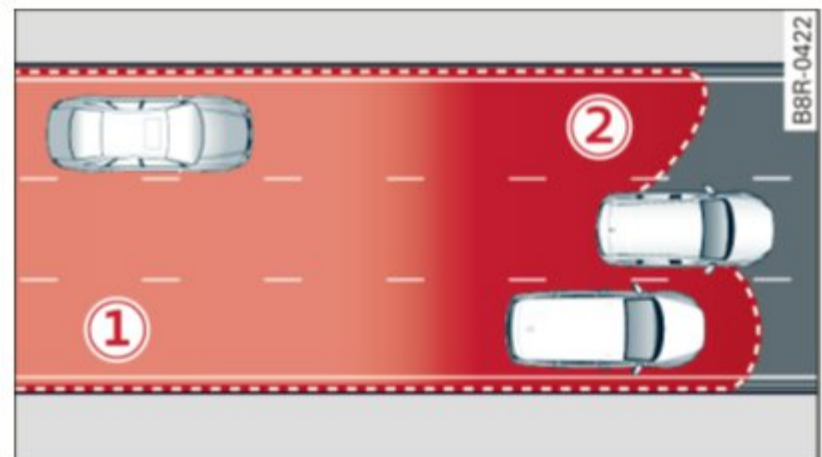

Fig. 150 Schematic illustration: Sensor detection area

The detection ⇒ *fig. 150* of the radar sensor detection area is made up of:

- the approach area (light red area) ①, about 230 feet (70 m) behind the vehicle, and
- the “blind spot” (dark red area) ②.

The radar sensors cover the adjacent left and right lanes. Other lanes are *not* covered by the radar sensors.

### i Tips

Side assist does not measure actual lane width. The system assumes a fixed lane width. Detection in the left and right lanes is based on this assumed lane width. When driving on narrow roads or when driving to the left or right of the center of a travel lane, it is possible that vehicles will be detected that are *not* in the lane

next to the lane you are using  
⇒ page 135.

## Operation

Applies to vehicles: with side assist

Side assist compares the distance and difference in speed of detected vehicles with the speed of your vehicle. Whenever the difference in speed and distance is registered as notable if you were to change lanes, a signal light appears on the respective mirror.

The signal can light up if you are passed by a vehicle or if you are passing another vehicle.

If you pass another vehicle slowly (difference in speed less than 9 mph, or 15 km/h), the signal light will come on as soon as the other vehicle is in your blind spot and is detected by side assist. When the difference in speed is greater, the signal light will not come on.

## Informational and alert stage signals

Applies to vehicles: with side assist

Side assist has two signal stages:

- the informational stage signal, and
- the alert stage signal.

Side assist helps you by using the appropriate signal stage, depending on whether or not you have activated the turn signal, and thus have indicated that you are or are not changing lanes.

### Informational stage signal

As long as you have not activated the turn signal, side assist informs you of detected vehicles that are registered as being in a notable location if you were to change lanes. Whenever the detected vehicle's difference in speed and distance is registered by side assist as notable, the signal light on the respective mirror produces muted illumination.

The brightness of the informational stage signal is designed not to be as intense, so that it does not interfere with your view of the road when you are driving and have no intention of changing lanes. When you look in the outside

mirror, you can clearly see the informational stage signal.

### Alert stage signal

When you activate the turn signal, and side assist has detected a vehicle in a notable location on that particular side, the signal light on this side mirror flashes brightly. The repeated brief and bright flashing of the alert stage signal reminds you to carefully check traffic to the rear in the outside mirror and over your shoulder, so that you can safely complete the lane change ⇒ ⚠ in *Safety tips on page 136*.

### **i** Tips

The brightness of the signal light on the outside mirrors can be adjusted with the MMI ⇒ page 134.

## Driving situation: Fast approaching vehicles

Applies to vehicles: with side assist

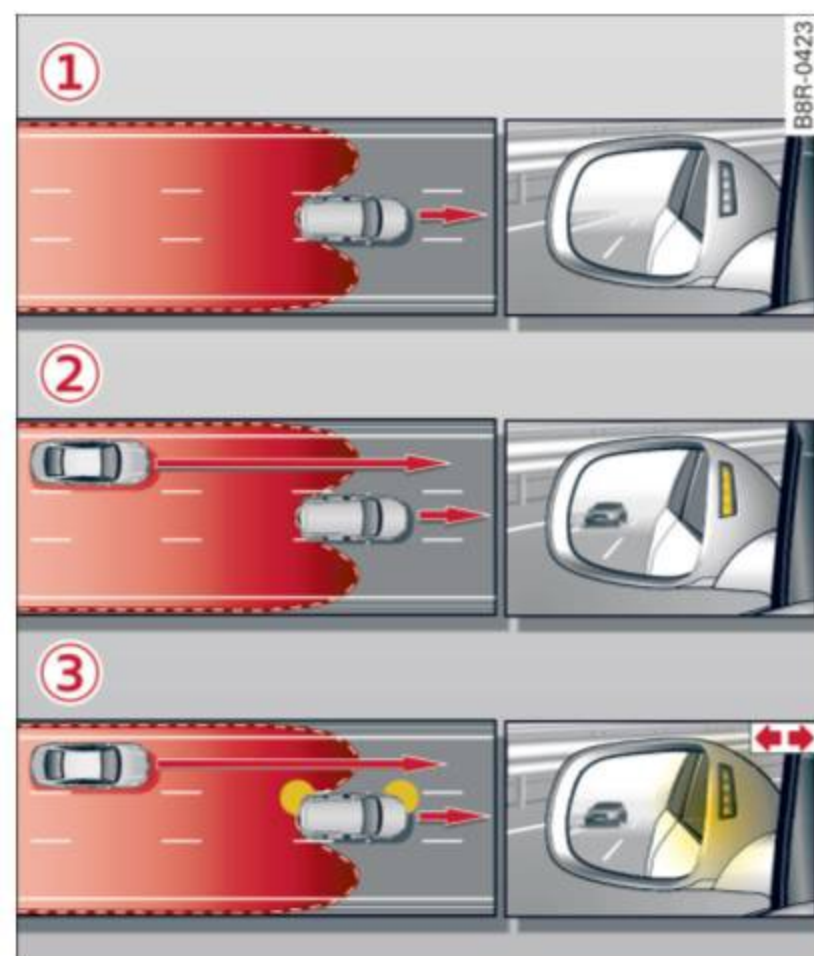

Fig. 151 Side assist: Fast approaching vehicles

### ① Signal on outside mirror does not light up

No vehicle was detected by the sensors. The signal on the outside mirror does not light up ⇒ ⚠ in *Safety tips on page 136*.

**② Informational stage signal lights up**

A fast approaching vehicle - in the left-hand lane for example - was detected by the sensors. Although this vehicle is still far away, it should be taken into account if you were to change lanes, due to the considerable difference in speed. The informational stage signal on the outside mirror lights up ⇒ *page 131*.

**③ Alert stage signal flashes**

If you activate your turn signal in driving situation ②, the signal briefly flashes repeatedly. Side assist is alerting you to a vehicle that you may not have noticed.

**i Tips**

- The faster a vehicle approaches from the rear, the sooner the signal on the outside mirror lights up. Side assist will signal, at the latest, when a detected vehicle enters your “blind spot”.
- When vehicles approach very quickly, changing lanes can be dangerous even if the signal on the outside mirror does not light up.

**Driving situation: Slowly approaching vehicles**

Applies to vehicles: with side assist

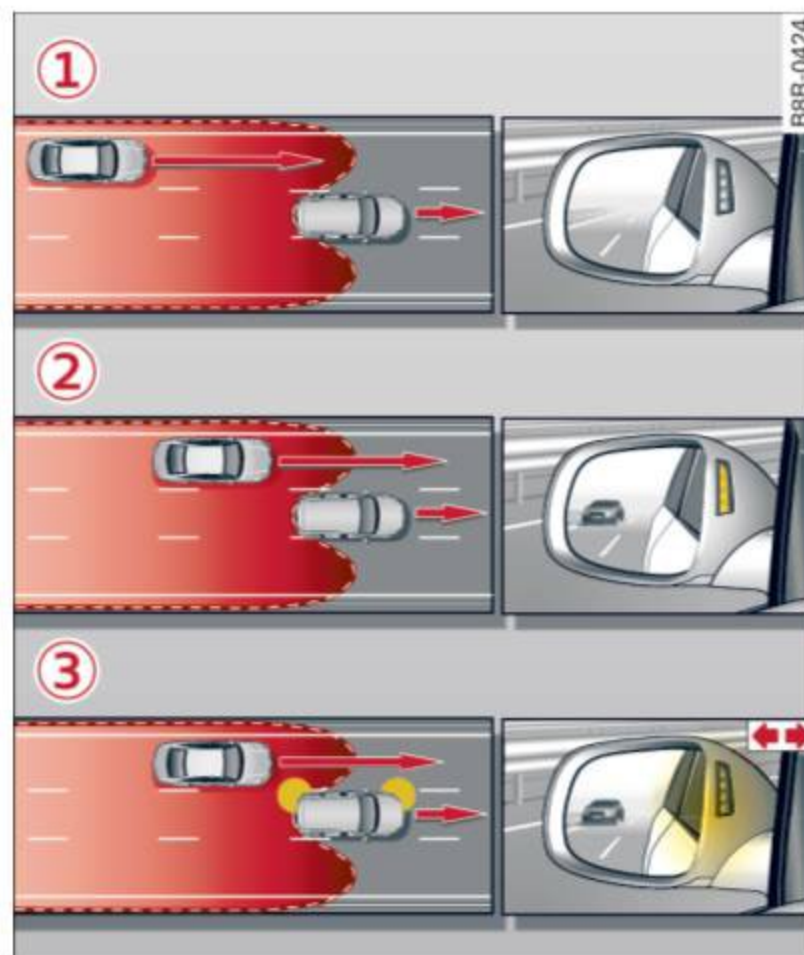

**Fig. 152** Side assist: Slowly approaching vehicles and vehicles in your blind spot

**① Signal on outside mirror does not light up**

A vehicle approaching slowly - in the left-hand lane for example - was detected by the sensors. Because of the small difference in speed and the considerable distance from your vehicle, the signal on the outside mirror will not light up ⇒ ⚠ in *Safety tips* on *page 136*.

**② Informational stage signal lights up**

The distance between your vehicle and that of the slowly approaching vehicle has narrowed. The informational stage signal on the outside mirror lights up.

As soon as the difference in speed and distance is registered as notable if you were to change lanes, a signal on the mirror lights up. Side assist will signal at the latest when a detected vehicle enters your “blind spot”.

### ③ Alert stage signal flashes

If you activate your turn signal in driving situation ②, the signal light briefly flashes repeatedly. Side assist is alerting you of a vehicle that you may not have noticed.

#### **i** Tips

- The faster a vehicle approaches from the rear, the sooner the signal on the outside mirror lights up. Side assist will signal, at the latest, when a detected vehicle enters your “blind spot”.
- When vehicles approach very quickly, changing lanes can be dangerous even if the signal on the outside mirror does not light up.

### Driving situation: Vehicles dropping back slowly

Applies to vehicles: with side assist

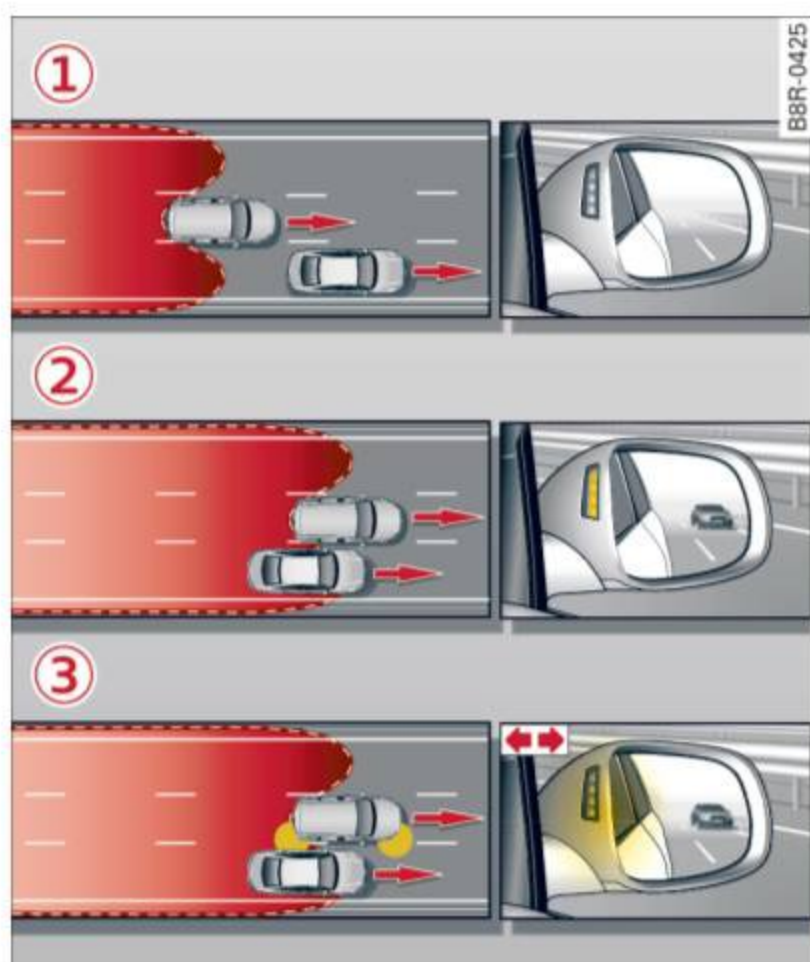

Fig. 153 Side assist: Vehicles dropping back slowly

### ① Signal on outside mirror does not light up

The vehicle that you passed has not yet been detected by side assist. The signal on the outside mirror does not light up ⇒ ⚠ in *Safety tips on page 136*.

### ② Informational stage signal lights up

A vehicle dropping back slowly on the right (difference in speed of less than 9 mph, or 15 km/h) has been detected by side assist. The informational stage signal on the outside mirror lights up.

### ③ Alert stage signal flashes

If you activate your turn signal in driving situation ②, the signal briefly flashes repeatedly. Side assist is alerting you of a vehicle that you may not have noticed.

### Driving situation: Vehicles dropping back quickly

Applies to vehicles: with side assist

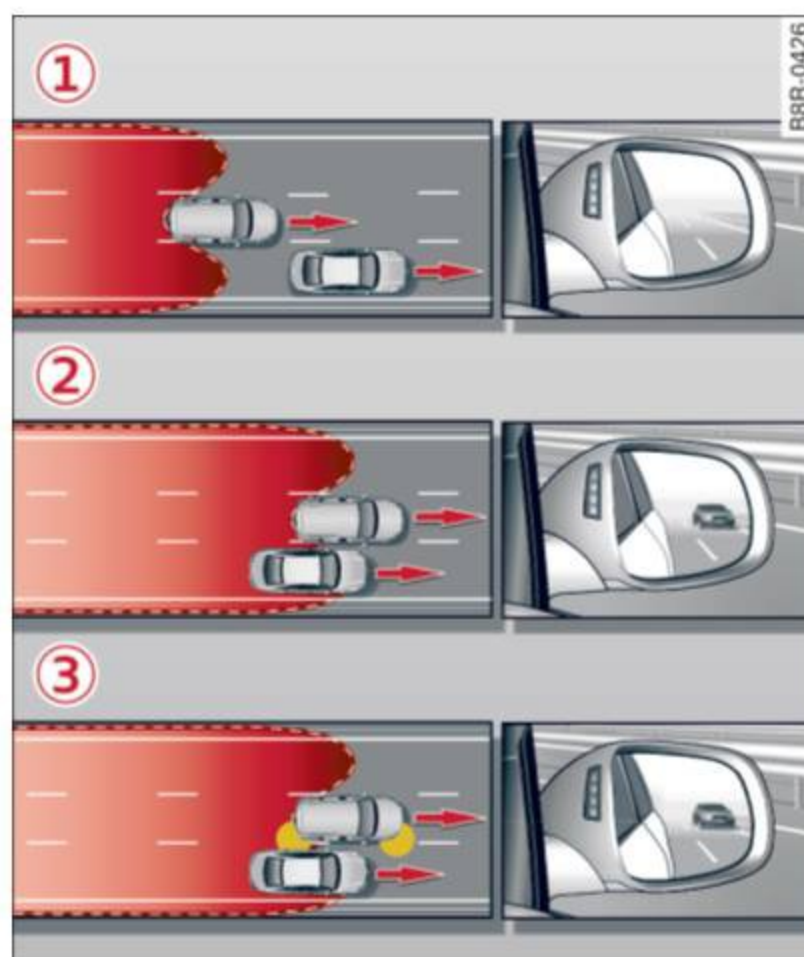



Fig. 154 Side assist: Vehicles dropping back quickly

### ① Signal on outside mirror does not light up

The vehicle just passed has not yet been detected by side assist. The signal on the outside mirror does not light up ⇒ ⚠ in *Safety tips on page 136*.

### ② Signal on outside mirror does not light up

The vehicle dropping back quickly on the right (difference in speed of more than 9 mph, or 15 km/h) has been detected by side assist, ▶

but is not considered notable in the event of a lane change, because it is dropping back so quickly. The signal on the outside mirror does not light up ⇒  in *Safety tips on page 136*.



### ③ Signal on outside mirror does not light up

If you activate your turn signal in driving situation ②, the signal still does not light up on the outside mirror ⇒  in *Safety tips on page 136*.

## MMI settings

Applies to vehicles: with side assist

*The basic brightness setting of the signal on the outside mirror can be adjusted via the MMI.*

- ▶ Select:  function button > **Systems\*** control button > **Audi side assist**. Or
- ▶ Select:  function button > **Car systems\*** control button > **Driver assist** > **Audi side assist**.

The brightness of the signal light for both the informational and alert stages is automatically adjusted to ambient light conditions. In addition, you can adjust the *basic brightness* separately, via the brightness function.

While making the adjustment, the new brightness setting is displayed briefly. The brightness displayed is that of the informational stage signal. The alert stage signal brightness is linked to the informational stage signal brightness.

The informational stage signal brightness should be adjusted so that you notice the signal illumination when you look in the outside mirror, but not when you look forward through the windshield.

In very dark or light surroundings, the automatic brightness setting adjusts signal light brightness to maximum or minimum intensity, as needed. In circumstances such as these, you may not notice any change in the brightness on the outside mirror when adjusting the *basic brightness*.

You may not notice the change until lighting conditions are normal again.

## Tips

- Side assist is not active when the basic brightness is adjusted. The signal light comes on briefly to help you make the adjustment.
- Your settings are automatically stored and assigned to the remote control key being used.

## General information

Applies to vehicles: with side assist

Side assist has limits and cannot detect vehicles under all road and weather conditions. Please remember system limitations and never rely on the system, especially when:

- driving through curves ⇒ *page 134*,
- lanes are of different widths ⇒ *page 135*.

## When driving through curves

Applies to vehicles: with side assist

Side assist cannot detect vehicles in curves with a turning radius of less than 328 feet (100 m).

When driving through a curve, it is possible that side assist may register a vehicle two lanes over, and the signal on the outside mirror will light up.

## Lane width

Applies to vehicles: with side assist

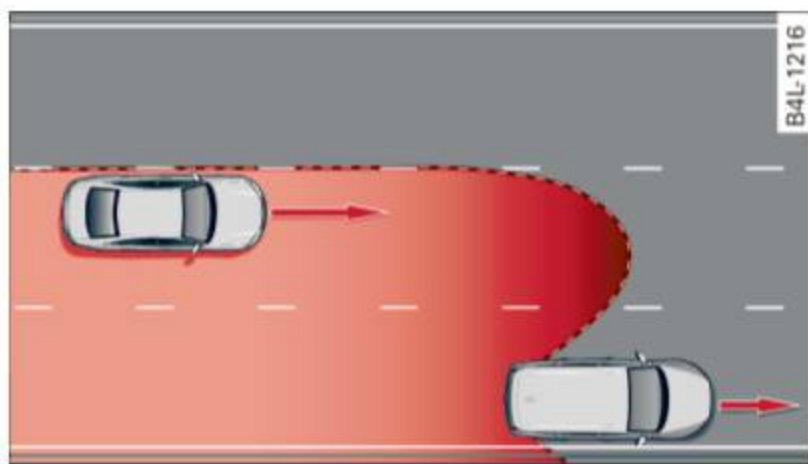

Fig. 155 Lanes of a normal width are in detection area

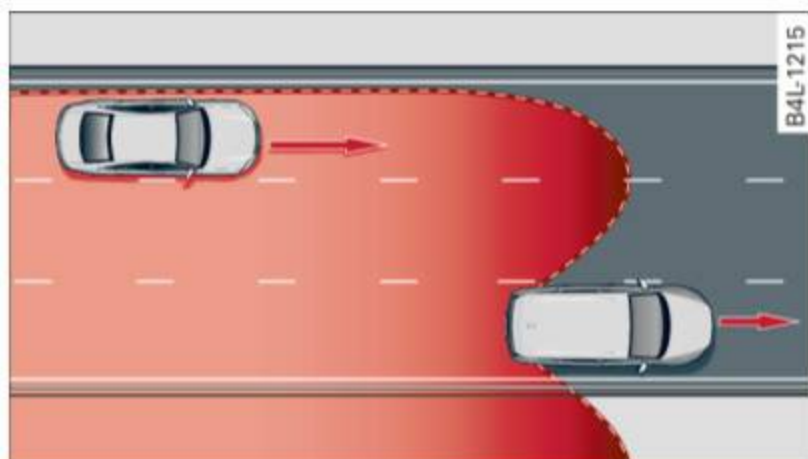

Fig. 156 Narrow lanes: Side assist may detect vehicles two lanes away

Side assist's detection area is designed to cover lanes of standard width to the left and right of your travel lane, depending on whether you drive in the center of your lane or closer to the edge.

If you drive in narrow lanes, side assist's detection area may also include other lanes - especially if you tend to drive on the edge of your lane ⇒ *fig. 156*. Under these conditions, vehicles can also be detected that are two lanes away, and side assist then could switch between the informational and warning stage signals.

When driving in very wide lanes, vehicles in the adjacent lane may not be detected because they are not inside the detection area.

## Notes

### Messages in instrument cluster display

Applies to vehicles: with side assist

If side assist turns off automatically, the indicator light on the button will go out and you

will see a message in the instrument cluster display:

### Audi side assist not available: sensors blocked

The side assist sensors are built into the rear bumper on the left and right (not visible on the outside) ⇒ *page 129, fig. 147*. To ensure that you do not adversely affect the way side assist functions, foreign objects (such as stickers or bicycle racks) should not be attached to the area on the rear bumper where the sensors are located. If side assist functions are adversely affected, you will see this message in the instrument cluster display. Remove anything that may be blocking the sensors.

If no vehicle is detected for a longer period of time while driving, side assist will also switch off automatically.

### Audi side assist currently not available

If there is a temporary problem (such as the vehicle's battery charge being low), side assist cannot be activated temporarily.

### Audi side assist: system fault

Have the system checked by an authorized Audi dealer or qualified workshop.

### Audi side assist not available when towing

The radar sensor's view is limited when towing a trailer. For vehicles with a factory installed towing hitch or a trailer hitch that was installed later according to factory specifications, side assist is automatically deactivated as soon as the electrical connection to the trailer's electrical socket is made, and this status message appears in the instrument cluster display. Deactivation cannot be guaranteed when using a retrofitted towing hitch that was **not** installed according to factory specifications.

**Safety tips**

Applies to vehicles: with side assist

The side assist detection may be limited when driving around narrow street corners, on hilly streets, and under poor weather conditions.

It is possible that the radar sensors may also detect other objects, such as high or staggered guardrails.

Side assist does not measure actual lane width. The system assumes a fixed lane width. Detection in the left and right lanes is based on this assumed lane width. When driving on narrow roads or when driving to the left or right of the center of a travel lane, it is possible that vehicles will be detected that are *not* in the lane next to the lane you are using.

**⚠ WARNING**

- Improper reliance on the side assist system can cause collisions and serious personal injury:
  - Never rely only on side assist when changing lanes.
  - Always check rear view mirrors to make sure that it is safe to change lanes.
- Side assist cannot detect all vehicles under all conditions- danger of accident!
- Side assist cannot detect vehicles in time to alert you when they approach from behind at very high speeds or drop back very quickly.
- The radar sensor's *vision* can be reduced or entirely blocked by rain, snow, and heavy spray. This can result in side assist not adequately detecting vehicles or, in some cases, not detecting them at all. Always keep an eye on the direction you are traveling and the relevant area around the vehicle.
- Please note that side assist indicates there are approaching vehicles, or vehicles in your blind spot, only after your vehicle has reached a driving speed of at least 19 mph (30 km/h).

- Side assist signal does not work around tight corners (turning radius less than 328 feet, or 100 m).
- Side assist is no replacement for the driver's full attention. The driver alone is responsible for lane changes and similar driving maneuvers. Always keep an eye on the direction you are traveling and the relevant area around the vehicle.

**! Note**

To ensure that side assist is not adversely affected, you should not block the area on the rear bumper where the radar sensors are located with foreign objects (such as with stickers or bicycle racks).

**i Tips**

If the positions of the radar sensors have been changed as a result of a rear end-collision, for instance, have side assist checked by an authorized Audi dealer for safety reasons.

## Automatic transmission

### tiptronic®

#### General information

Your vehicle is equipped with an electronically controlled automatic transmission. Upshifting and downshifting takes place *automatically*.

The transmission is also equipped with tiptronic®. It allows the driver to shift gears *manually* if desired ⇒ *page 140*.

#### Driving the automatic transmission



Fig. 157 Shift gate on the center console: selector lever with release button

#### Starting the engine

- ▶ The selector lever must be in **N** or **P**.

#### Starting off

- ▶ Press and hold the brake pedal.
- ▶ Press and hold the release button in the selector lever handle and move the selector lever from **P** or **N** to **D** and release the button ⇒ ⚠.
- ▶ Wait briefly until the transmission has shifted (you will feel a slight movement).
- ▶ Remove your foot from the brake pedal and accelerate.

#### Rocking back and forth to become unstuck

- ▶ Shift only between **D** and **R** when the vehicle is at a full stop and the engine is running at idle speed.

#### Stopping

- ▶ Press and hold the brake pedal until the vehicle has come to a complete stop.
- ▶ Keep the brake pedal depressed so that the vehicle cannot roll forward or backward while it is idling ⇒ ⚠.
- ▶ Once stopped, *do not* depress the accelerator pedal to rev up the engine ⇒ ⚠.

#### Parking

- ▶ Press and hold the brake pedal until the vehicle has come to a complete stop.
- ▶ Set the parking brake firmly ⇒ *page 110, Parking*.
- ▶ Press and hold the release button in the selector lever handle, move the selector lever into **P** and then let go of the release button ⇒ ⚠.

The selector lever must be in **N** or **P**. If one of the driving positions is engaged a safety switch will prevent the engine from being started. See also ⇒ *page 106*.

Before you move the selector lever from the **P** position, you must always apply the brake pedal before and while depressing the button in the handle of the selector lever.

#### ⚠ WARNING

- Unintended vehicle movement can cause serious injury.
- When the selector lever is in a driving position, the vehicle may creep, even at idle speed. Therefore do not release the parking brake or foot brake until you are ready to move, because power is transmitted to the wheels as soon as a driving position is engaged.
- Do not accelerate while selecting a driving position. At this time the engine must be at idle speed so that undue stress is not placed on the clutches in the transmission.
- Remember: - even when stopped briefly with the automatic transmission in “D”, “S” or “R”, engine power is being transmitted to the wheels. Your vehicle

could “creep” forward or backward. When stopped, keep the brake pedal fully depressed and use the parking brake if necessary to keep the vehicle from rolling.

- If the selector lever is unintentionally moved into N while you are driving, take your foot off the accelerator pedal and wait for the engine to return to idle speed before selecting a driving position.
- Never shift into “R” or “P” when the vehicle is in motion.
- Never get out of the driver’s seat when the engine is running.
- If you must get out of the vehicle, move the selector lever securely into the P position and apply the parking brake firmly.
- If the engine must remain running, never have any driving position engaged when checking under the hood. Make sure the selector lever has securely engaged and is locked in “P” with the parking brake firmly set ⇒ *page 255, Engine compartment*. Otherwise, any increase in engine speed may set the vehicle in motion, even with the parking brake applied.

### Selector lever positions

This section describes the selector lever positions and driving ranges.



**Fig. 158** Display in the instrument cluster: selector lever in position P

The instrument cluster display shows the current selector lever position.

### P - Park

In this selector lever position the transmission is mechanically locked. Engage **P** only when the vehicle is *completely stopped* ⇒ ⚠ in *Driving the automatic transmission on page 137*.

To shift in or out of position **P**, you must *first* press and hold the brake pedal *and then* press the release button in the selector lever handle while moving the selector lever to or from **P**. You can shift out of this position only with the ignition on.

### R - Reverse

The transmission will automatically select the **lowest gear ratio** when you shift into reverse.

Select **R** only when the vehicle is at a *full stop* and the engine is running at idle speed ⇒ ⚠ in *Driving the automatic transmission on page 137*.

Before you move the selector lever to **R**, press *both* the button in the handle of the selector lever *and* the brake pedal at the same time.

When the ignition is on, the backup lights illuminate when the selector lever is moved into **R**.

### N - Neutral

The transmission is in neutral in this position. Shift to this position for standing with the brakes applied ⇒ *page 139*.

When the vehicle is stationary or at speeds below 3 mph (5 km/h), you must always apply the footbrake before and while moving the lever out of **N**.

### D - Normal position for driving forward

Position **D** is for normal city and highway driving. It ranges from zero to top speed and all gears shift automatically, depending on engine load, driving speed and automatically selected shift programs.

When the vehicle is stationary or at speeds below 3 mph (5 km/h), you must always apply ►

the foot brake before and while moving the lever to **D** out of **N**.

In certain circumstances it may be advantageous to temporarily switch to the manual shift program to manually select gear ratios to match specific driving conditions ⇒ page 140.

### S – Sport position

Select this position for sportier performance. In this position, the transmission will not up-shift as soon, allowing the vehicle to use the increased power available at higher engine speeds to achieve livelier acceleration.

When the vehicle is stationary or at speeds below 3 mph (5 km/h), you must always apply the foot brake before and while moving the lever to **S** out of **N**.

#### WARNING

Read and follow all WARNINGS ⇒  in *Driving the automatic transmission on page 137*.

#### Note

Coasting downhill with the transmission in **N** and the engine not running will result in damage to the automatic transmission and possibly the catalytic converter.

### Automatic Shift Lock (ASL)

The Automatic Shift Lock safeguards you against accidentally shifting into a forward or the reverse gear and causing the vehicle to move unintentionally.



**Fig. 159** Shift gate: selector lever lock positions and interlock button highlighted

The selector lever lock is released as follows:

- ▶ Turn the ignition on.
- ▶ Step on the brake pedal. *At the same time* press and hold the interlock button on the side of the gear selector knob ⇒ *fig. 159* with your thumb until you have moved the selector lever to the desired position.

### Automatic selector lever lock

The selector lever is locked in the **P** and **N** positions when the ignition is turned on. To move the lever from these positions the driver must depress the brake pedal. As a reminder to the driver, the following warning appears in the instrument cluster display when the selector is in **P** and **N**:

#### When stationary apply foot brake while selecting gear

A time delay element prevents the selector lever from locking when it is moved through the **N** position (going from **R** to **D**). The locking element will lock the selector lever if the lever is left in **N** (Neutral) for more than approximately 1 second, without the brake pedal being pressed.

At speeds above about 3 mph (5 km/h) the Automatic Shift Lock is automatically deactivated in the **N** position.

### Interlock button

The lock button on the selector lever prevents the lever from being accidentally shifted into certain positions. Pressing this button deactivates the selector lever lock. Depending on the direction of the shift, the selector lever locks at different positions. The positions are highlighted in the illustration ⇒ *fig. 159*.

### Ignition key safety interlock

The key cannot be removed from the ignition unless the selector lever is in the **P** park position. When the ignition key is removed, the selector lever will be locked in the **P** position.

### Kick-down

The kick-down feature allows the vehicle to generate maximum acceleration.

When you press the accelerator pedal beyond the resistance point that is reached at full throttle, the transmission will select a lower gear ratio based on vehicle speed and engine RPM. The engine RPM will be controlled to produce maximum vehicle acceleration as long as you continue to press the accelerator pedal beyond this resistance point.

#### WARNING

Be careful when using the kick-down feature on slippery roads. Rapid acceleration may cause the vehicle to skid.

### Dynamic shift program (DSP)

The automatic transmission is electronically controlled.

The transmission is self adapting and will **automatically** select the best shift program suited to the driving conditions and driving style.

The transmission will select one of the **economy** programs when you drive at a steady speed or a gradually changing speed without heavy acceleration. This achieves optimum fuel efficiency, with early upshifting and delayed downshifting.

The transmission will automatically select the **sporty** shift programs when you drive at higher speeds, or with heavy acceleration and frequently changing speeds. Upshifts are delayed to make full use of engine power. Downshifting takes place at higher engine speeds than in the economy programs.

The selection of the most suitable shift program is a continuous, automatic process. The driver can also make the transmission switch to a sporty program by **quickly** pressing down the gas pedal.

This causes the transmission to shift down to a lower gear to achieve rapid acceleration, e.g. for quickly passing another vehicle. You do not

need to press the gas pedal into the kick-down range. After the transmission has upshifted, the original program is selected according to your driving style.

An additional shift program allows the automatic transmission to select the proper gear for uphill and downhill gradients.

This keeps the transmission from shifting up and down unnecessarily on hills. The transmission will shift down to a lower gear when the driver presses the brake pedal on a downhill gradient. This makes use of the braking effect of the engine without the need to shift down manually.

### Manual shift program

Using the manual shift program you can manually select gears.



Fig. 160 Center console: shifting the tiptronic® manually



Fig. 161 Display: manual shift program, selected gear

### Switching to manual shift program

- Push the selector lever to the right from D. As soon as the transmission has switched over, the selected gear appears in the display ⇨ fig. 161.

### To upshift

- ▶ Push the selector lever forward to the plus position  ⇒ fig. 160.

### To downshift

- ▶ Push the lever to the minus position .

When accelerating, the transmission will automatically shift into the next gear before the engine reaches its maximum RPM.

If you apply a light throttle when accelerating, tiptronic® will automatically shift from 1st to 2nd gear to save fuel. If you apply a heavy throttle, the transmission will stay in 1st gear until near maximum RPM is reached, or until the driver shifts into 2nd gear.

If you take your foot off the accelerator pedal when driving down a steep incline, tiptronic® will downshift from the selected gear into the next lower gear until it reaches 1st gear, based on road speed and engine RPM. Automatic downshifting is interrupted as soon as you apply the throttle again.

### Tips

- When you shift into the next lower gear, the transmission will downshift only when there is no possibility of over-revving the engine.
- When the kick-down comes on, the transmission will shift down to a lower gear, depending on vehicle and engine speeds.
- tiptronic® is inoperative when the transmission is in the fail-safe mode.



### Steering wheel with tiptronic®

Applies to vehicles: with tiptronic-steering wheel

*The shift buttons on the steering wheel allow the driver to shift gears manually.*



Fig. 162 Steering wheel: Shift buttons

- ▶ To downshift, touch the button on the left .
- ▶ To upshift, touch the button on the right .

The shift buttons are activated when the selector lever is in D, S or in the manual shift program (tiptronic).

Of course, you can continue to use the manual shift program with the selector lever on the center console.

### Automatic transmission malfunction

#### Transmission malfunction: You can continue driving

There is a system malfunction in the transmission. You may continue driving. Drive to your authorized Audi dealer or qualified repair facility soon to have the malfunction corrected.

#### Transmission malfunction: Limited driving functionality

There is a system malfunction in the transmission. The transmission is switching to emergency mode. This mode only shifts into certain gears or will no longer shift at all. The engine may stall. Drive to your authorized Audi dealer or qualified repair facility immediately to have the malfunction corrected. ▶

**!** Note

If the transmission switches to emergency mode, you should take the vehicle to an authorized Audi dealership as soon as possible to have the condition corrected.

**Emergency release for selector lever**

*If the vehicle's power supply fails, the selector lever can be released in an emergency.*



**Fig. 163** Emergency release for selector lever

The emergency release is located under a rubber mat.

- ▶ Carefully lift the rubber mat with a screwdriver or something similar ⇒ *fig. 163*.
- ▶ You now have access to a rocker switch. Using a screwdriver or similar object, press the rocker switch down and hold it down.
- ▶ Now press the interlock and move the selector lever to the **N** position.

The selector lever can only be moved from the **P** position if the ignition key is in the lock and the ignition is turned on. If the vehicle has to be pushed or towed if the power supply fails (e.g. battery is discharged), the selector lever must be moved to the **N** position using the emergency locking device.

## Parking systems

### General information

Applies to vehicles: with rear park assist/Audi parking system plus with rearview camera/front- and rearview camera

Depending on your vehicle's equipment, various parking aids will help you when parking and maneuvering.

The **rear park assist** is an acoustic park assist system that will give you a sound warning to let you know there is something *behind* the vehicle ⇒ *page 144*.

The **Audi parking system plus with rearview camera** audibly and visually tells you there is something *in front of* and *behind* the vehicle. A rearview camera also shows you what is behind the vehicle ⇒ *page 144*.

The **Audi parking system plus with front- and rearview camera** audibly and visually tells you there is something *in front of* and *behind* the vehicle. A front and rearview camera also shows you what is in front of and behind the vehicle ⇒ *page 148*.

#### WARNING

- Always look for traffic and check the area around your vehicle by looking at it directly as well. The parking system cannot replace the driver's attention. The driver is always responsible for safety during parking and for all other maneuvers.
- Please note that some surfaces, such as clothing, are not detected by the system.
- Sensors and cameras have blind spots in which people and objects cannot be detected. Be especially cautious of children and animals.
- The sensors can be displaced by impacts or damage to the radiator grille, bumper, wheel housing and the underbody. The parking systems may become impaired as a result. Have your authorized Audi dealer or qualified workshop check their function.
- Make sure the sensors are not covered by stickers, deposits or any other obstruc-

tions as it may impair the sensor function. For information on cleaning, refer to ⇒ *page 247*.

#### Note

- Some objects are not detected by the system under certain circumstances:
  - Objects such as barrier chains, trailer draw bars, vertical poles or fences
  - Objects above the sensors such as wall extensions
  - Objects with specific surfaces or structures such as chain link fences or powder snow.
- If you continue driving closer to a low-lying object, it may disappear from the sensor range. Note that you will no longer be warned about this obstacle.

#### Tips

- The system may provide a warning even though there are no obstacles in the coverage area in some situations, such as:
  - certain road surfaces or for long grass.
  - external ultrasonic sources e.g. from cleaning vehicles.
  - heavy rain, snow or thick vehicle exhaust.
- We recommend that you practice parking in a traffic-free location or parking lot to become familiar with the system. When doing this, there should be good light and weather conditions.
- You can change the volume and pitch of the signals as well as the display ⇒ *page 153*.
- Please refer to the instructions for towing a trailer ⇒ *page 153*.
- What appears in the MMI display is somewhat time-delayed.

## Rear park assist

### Description

Applies to vehicles: with rear park assist

*The rear park assist is an audible system.*

Sensors are located in the rear bumpers. If these detect an obstacle, audible signals warn you.

Make sure the sensors are not covered by stickers, deposits or any other obstructions as it may impair the sensor function. For information on cleaning, refer to ⇒ *page 247*.

The range at which the sensors begin to measure is approximately:

|      |        |                 |
|------|--------|-----------------|
| rear | side   | 2 ft (0.60 m)   |
|      | center | 5.2 ft (1.60 m) |

The closer you get to the obstacle, the shorter the interval between the audible signals. A continuous tone sounds when the obstacle is less than approximately 1 ft (0.30 m) away. Do not continue driving farther ⇒ ⚠ in *General information on page 143*, ⇒ ⚠ in *General information on page 143*!

If the distance to an obstacle remains constant, the volume of the distance warning gradually drops after about four seconds (this does not apply in the continuous tone range).

The park assist is activated automatically when reverse gear is engaged. A short confirmation tone sounds.

## Audi parking system plus with rearview camera

### Introduction

Applies to vehicles: with Audi parking system plus with rearview camera

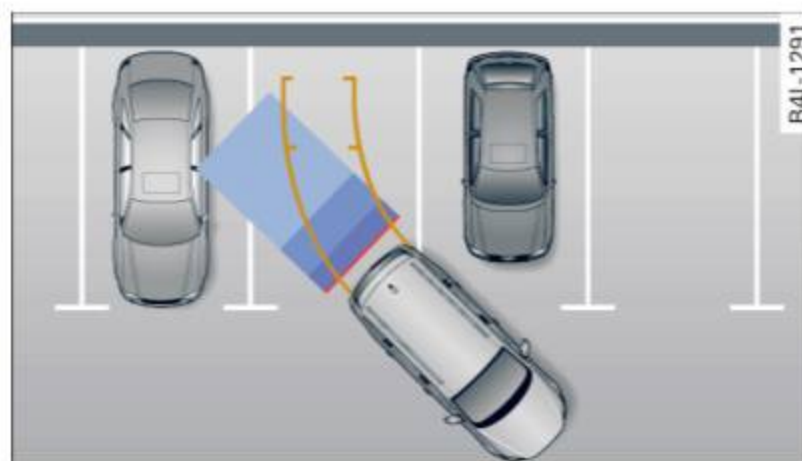

Fig. 164 Illustration: Cross parking

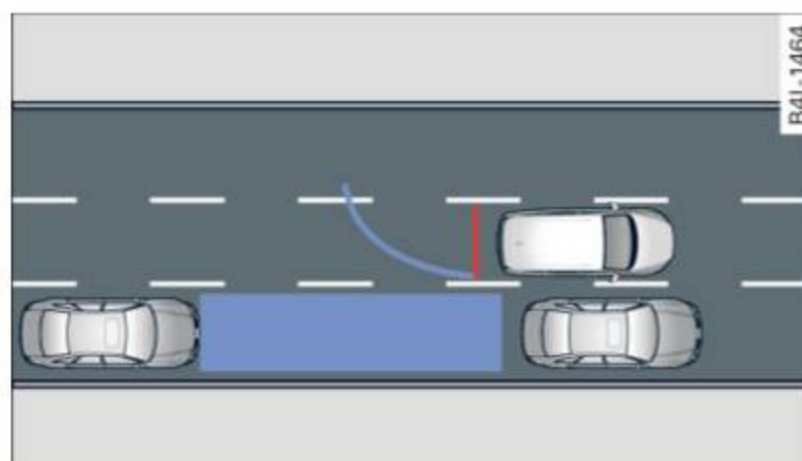

Fig. 165 Illustration: Parallel parking

Vehicles with the Audi parking system plus with rearview camera are equipped with a **rearview camera** in addition to the acoustic and visual parking system.

You can use *cross parking* for example, to park in a parking space or in a garage ⇒ *fig. 164*. You can use *parallel parking* if you would like to park on the side of the road ⇒ *fig. 165*.

### General Information

Applies to vehicles: with Audi parking system plus with rearview camera

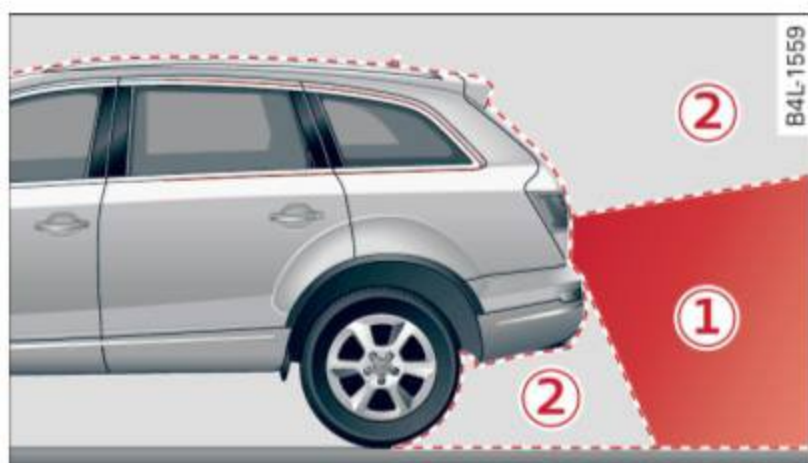

Fig. 166 Area covered ① and area not covered ② by the rearview camera.



Fig. 167 Rear lid: Location of the rearview camera

### Sensors

Sensors are located in the front and rear bumpers. If these detect an obstacle, audible and visual signals warn you.

Make sure the sensors are not covered by stickers, deposits or any other obstructions as it may impair the sensor function. For information on cleaning, refer to ⇒ page 247.

The range at which the sensors begin to measure is approximately:

|       |        |                 |
|-------|--------|-----------------|
| front | side   | 3 ft (0.90 m)   |
|       | center | 4 ft (1.20 m)   |
| rear  | side   | 2 ft (0.60 m)   |
|       | center | 5.2 ft (1.60 m) |

The closer you get to the obstacle, the shorter the interval between the audible signals. A continuous tone sounds when the obstacle is less than approximately 1 ft (0.30 m) away. Do not continue driving farther forward or in reverse ⇒ ⚠ in General information on

page 143, ⇒ ⚠ in General information on page 143.

If the distance to an obstacle remains constant, the volume of the distance warning gradually drops after about four seconds (this does not apply in the continuous tone range).

### Rearview camera

The rearview camera is located above the rear license plate bracket. Make sure that the lens for the parking system ⇒ fig. 167 is not covered by deposits or any other obstructions because this can affect the function of the parking system. For information on cleaning, refer to ⇒ page 247.

The rearview camera coverage area includes ① ⇒ fig. 166. Only this area is displayed in the MMI. Objects that are outside of this area ② are not displayed.

The orientation lines become less accurate and the blue surfaces diminish if the Adaptive Air Suspension\* is faulty, the vehicle is lifted or cargo mode is activated, or if the **Dynamic, Offroad** or **Lift** mode is set ⇒ page 155.

### ⚠ WARNING

- Always read and follow the applicable warnings ⇒ ⚠ in General information on page 143.
- If the position and the installation angle of the rearview camera was changed, for example, after a collision, do not continue to use the system for safety reasons. Have it checked by your authorized Audi dealership or authorized repair facility.
- Only use the rearview camera to assist you if it shows a good, clear picture. For example, the image may be affected by the sun shining into the lens, dirt on the lens or if there is a system fault.
- Use the rearview camera only if the luggage compartment lid is completely closed. Make sure any objects you may have mounted on the luggage compartment lid do not block the rearview camera.

- The camera lens enlarges and distorts the field of vision. The object appears both altered and inaccurate on the screen.
- In certain situations, people or objects in the display appear closer or further away:
  - objects that do not touch the ground, such as the bumper of a parked vehicle, a trailer hitch or the rear of a truck. Do not use the help lines in this case.
  - If driven from a level surface onto an incline, or a downward slope.
  - If driven toward protruding objects.
  - If the vehicle is carrying too much load in the rear.

### Note

- Always read and follow the applicable warnings ⇒  in *General information on page 143*.
- The orange colored orientation lines in the MMI display show the vehicle path depending on the steering wheel angle. The front of the vehicle front swings out more than the rear of the vehicle. Maintain plenty of distance so that your outside mirror or a corner of your vehicle does not collide with any obstacles.

### Switching on and off

Applies to vehicles: with Audi parking system plus with rearview camera



Fig. 168 Center console: P button



Fig. 169 MMI display: Visual distance display

### Switching on

- ▶ Switch the MMI on.
- ▶ Shift into reverse, or
- ▶ Press the  button in the center console ⇒ *fig. 168*. A short confirmation tone sounds and the LED in the button lights up.



### Switching between the rearview camera and visual display

- ▶ Press the **Graphic** control button ⇒ *page 147, fig. 170*  to see the visual display.
- ▶ Press the **Rear view** control button to see the rearview camera image ⇒ *fig. 169*.

### Switching off

- ▶ Drive faster than 6 mph (10 km/h), or
- ▶ Press the  button, or
- ▶ Switch off the ignition.

### Visual display

The red segments in front of and behind the vehicle ⇒ *fig. 169* help you to determine the distance between you and an obstacle. As your vehicle comes closer to the obstacle, the segments move closer to the vehicle. The collision area has been reached when the next to last segment is displayed. Do not continue driving farther forward or in reverse ⇒  in *General information on page 143*, ⇒  in *General information on page 143*.

### Tips

- The visual display in the left part of the display should help you detect the critical vehicle areas.

– You can change the volume and pitch of the signals as well as the display  
⇒ page 153.

### Cross parking

Applies to vehicles: with Audi parking system plus with rearview camera

This view may be used when parking in a garage or in a parking space.

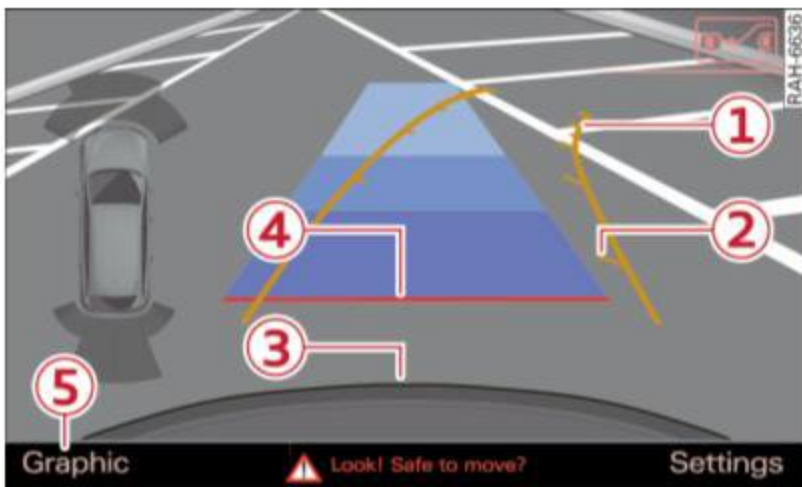

Fig. 170 MMI display: Aiming at a parking space

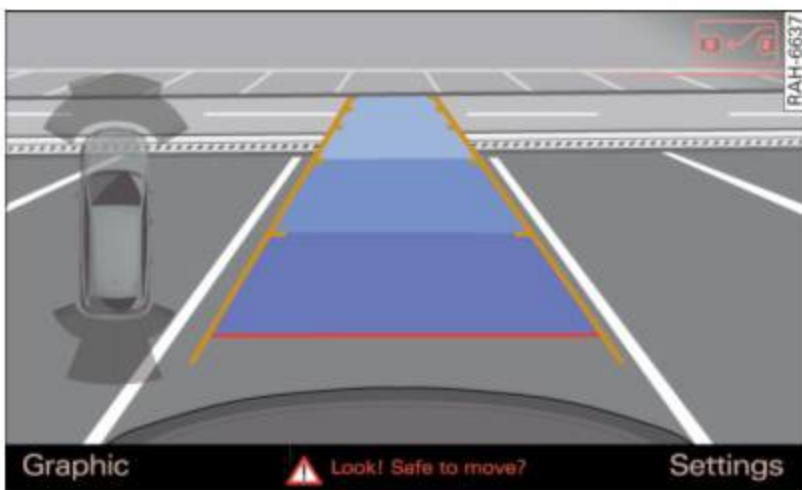

Fig. 171 MMI display: Aligning the vehicle

- ▶ Switch the MMI on and select reverse gear.
- ▶ The orange colored orientation lines ① show the direction of travel of the vehicle. Turn the steering wheel until the orange orientation lines appear in the parking space ⇒ fig. 170. Use the markings ② to help you estimate the distance from an obstacle. Each marking represents approximately 3 ft (1 m). The blue area represents an extension of the vehicle's outline by approximately 16 ft (5 m) to the rear.
- ▶ While driving in reverse gear, adjust the steering wheel angle to fit the parking space with the aid of the orange orientation lines ⇒ ⚠ in General Information on page 145, ⇒ ⚠ in General Information on page 146. ③ marks the rear bumper. Stop the vehicle

when the red orientation line ④ borders an obstacle.

### Parallel parking

Applies to vehicles: with Audi parking system plus with rearview camera

This view may be used when parallel parking along the side of a street.

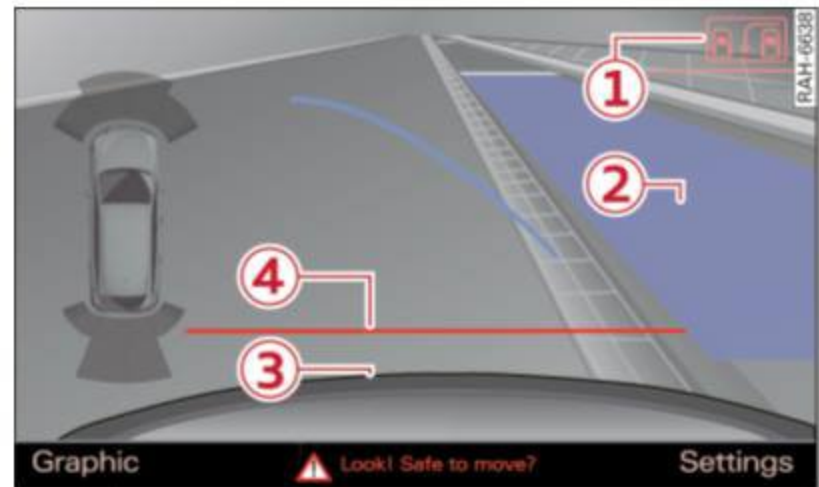

Fig. 172 MMI display: Blue surface aligned in the parking space

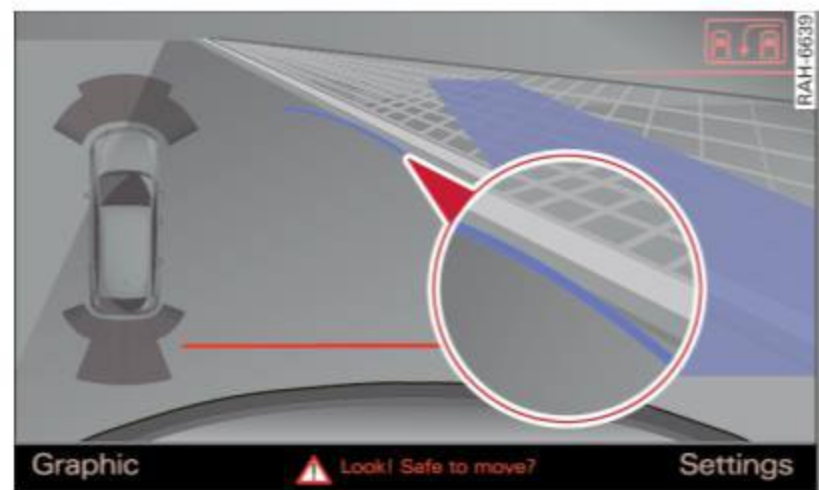

Fig. 173 MMI display: Contact of the blue curve with the curb

Parking on the right is described here. It is identical when parking on the left.

If there is an obstacle next to the parking space (such as a wall), refer to information for "Parking next to obstacles" ⇒ page 148.

- ▶ Activate the turn signal.
- ▶ Position your vehicle next to a parked vehicle in front of the desired parking space. The distance to this vehicle should be approximately 3 ft (1 m).
- ▶ Turn the MMI on and select the reverse gear. The parking system is turned on and the *cross parking* indicator is displayed.
- ▶ Press the control button on the MMI controls ① ⇒ fig. 172. The *parallel parking* indicator is displayed.

- ▶ Back up and align your vehicle so the blue area ② borders on the rear end of the vehicle or on the parking space line ⇒ ⚠ in *General Information on page 145*, ⇒ ⚠ in *General Information on page 146*. The blue area represents an extension of the vehicle's outline by approximately 16 ft (5 m) to the rear. The long side of the blue area should be on the curb. The entire blue area must fit into the parking space.
- ▶ With the vehicle stopped, turn the steering wheel to the right as far as it will go.
- ▶ Back into the parking space until the blue curve ⇒ *fig. 173* touches the curb ⇒ ⚠ in *General Information on page 145*, ⇒ ⚠ in *General Information on page 146*. Stop the vehicle.
- ▶ With the vehicle stopped, turn the steering wheel to the left as far as it will go.
- ▶ Continue to back into the parking space until the vehicle is parked parallel to the curb ⇒ ⚠ in *General Information on page 145*, ⇒ ⚠ in *General Information on page 146*. ③ marks the rear bumper. Stop the vehicle, at the latest, when the red orientation line ④ borders an obstacle. Keep an eye on the front of your vehicle while doing this.

### Parking next to obstacles

When there is an obstacle (such as a wall) next to the parking space, choose a space with more space on the sides. Position the long side of the blue area so that there is sufficient space from the curb. The area must not be on the curb. You will also need to start turning the steering wheel much earlier. There should be a sufficient amount of space between the curb and the blue curve, and the blue curve ⇒ *fig. 173* must **not** touch the curb.

#### **i** Tips

The left or right orientation lines and surfaces will be displayed, depending on the turn signal being used.

## Audi parking system plus with front- and rearview camera

### Introduction

Applies to vehicles: with Audi parking system plus with front- and rearview camera

In addition to an acoustic and visual parking system, this parking system contains a front and rearview camera ⇒ *page 146*. You are assisted by various views, such as corner views at the front and rear of the vehicle, and views directly in front of or behind the vehicle.

### General information

Applies to vehicles: with Audi parking system plus with front- and rearview camera

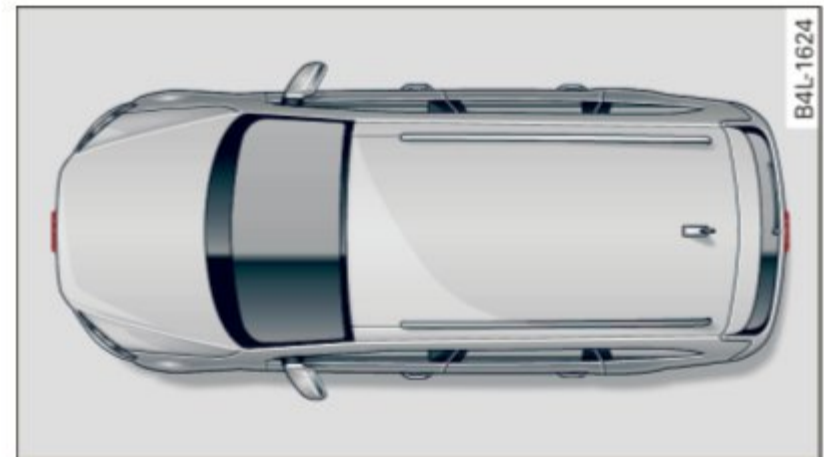

**Fig. 174** Installed location of the front and rear camera

The front camera is found in the radiator grille and the rearview camera is located in the rear lid ⇒ *fig. 174*. Make sure that the lenses are not covered by deposits or any other obstructions as it may impair the system. For information on cleaning, refer to ⇒ *page 247*.

The orientation lines become less accurate and the blue surfaces diminish if the Adaptive Air Suspension\* is faulty, the vehicle is lifted or cargo mode is activated, or if the **Dynamic, Offroad** or **Lift** mode is set ⇒ *page 155*.

#### **⚠ WARNING**

- Always read and follow the applicable warnings ⇒ ⚠ in *General information on page 143*.

- If the position or the installation angle of a camera was changed, after a collision for example, do not continue to use the system for safety reasons. Have it checked by your authorized Audi dealership.
- Use the **Rear** mode and the **Corner view (rear)** mode only when the rear lid is completely closed, otherwise the image in the display will be inaccurate.
- Objects and obstacles above the camera are not displayed.
- Camera lenses enlarge and distort the field of vision. The objects appear both altered and inaccurate on the screen.

**! Note**

- Always read and follow the applicable warnings ⇒ **!** in *General information on page 143*.
- The MMI display shows the direction in which the rear of the vehicle is traveling based on the steering wheel angle. The vehicle front swings out more than the vehicle rear. Maintain plenty of distance so that your outside mirror or a corner of your vehicle does not collide with any obstacles.

**i Tips**

If the rear lid is open, the image in the rearview camera is displayed without orientation lines and without blue surfaces.

**Switching on or off**

Applies to vehicles: with Audi parking system plus with front- and rearview camera



Fig. 175 Center console: P button

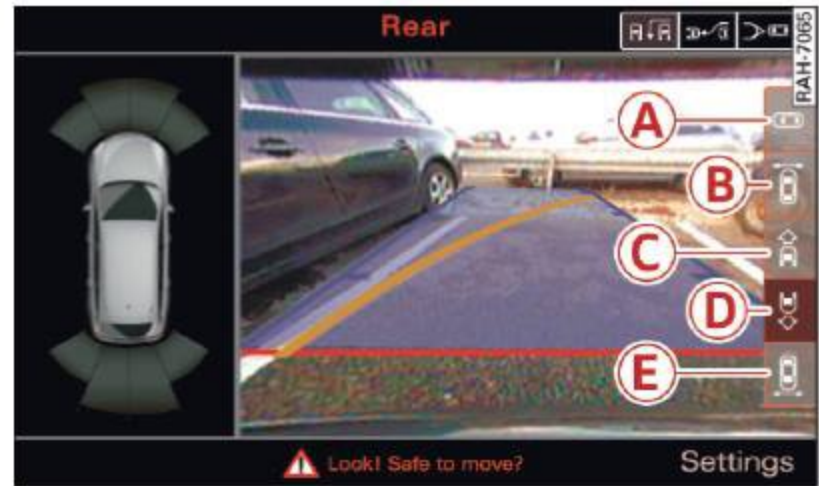

Fig. 176 MMI display: Select mode

**Switching on**

- ▶ Switch the MMI on.
- ▶ Shift into reverse, or
- ▶ Press the **P** button in the center console ⇒ *fig. 175*. A short confirmation tone sounds and the LED in the button lights up.

**Selecting the mode**

- ▶ Turn the control knob to the symbol for the desired mode **A** through **E** ⇒ *fig. 176*.

**Switching off**

- ▶ Drive faster than 6 mph (10 km/h), or
- ▶ Press the **P** button, or
- ▶ Switch off the ignition.

You may select from the following modes:

- A** Top view ⇒ *page 150*
- B** Corner view (front) ⇒ *page 150*
- C** Front ⇒ *page 150*
- D** Rear ⇒ *page 150*
- E** Corner view (rear) ⇒ *page 150*

**i Tips**

The visual display in the left part of the display should help you detect the critical vehicle areas.

### Top view

Applies to vehicles: with Audi parking system plus with front- and rearview camera



Fig. 177 MMI display: Top view mode

This view is ideal for maneuvering. The visual field appears in the display.

- ▶ Select the **A** symbol with the control knob.

### Corner view (front)/(rear)

Applies to vehicles: with Audi parking system plus with front- and rearview camera



Fig. 178 MMI display: Corner view (front) mode

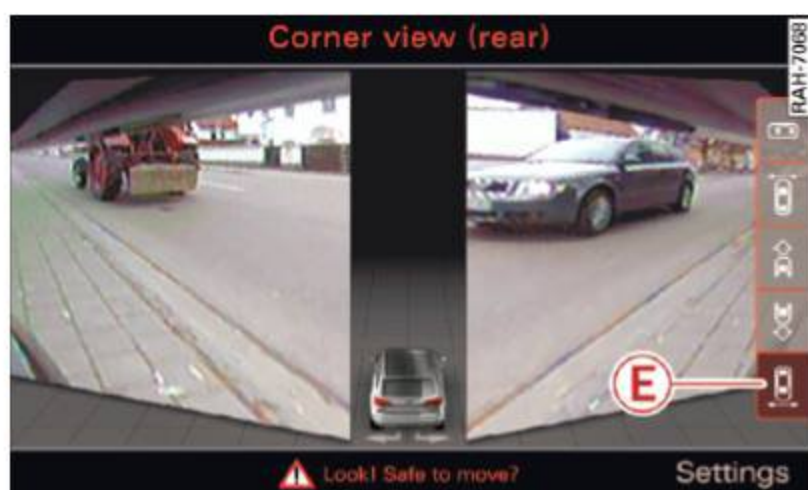

Fig. 179 MMI display: Corner view (rear) mode

This view can assist you for example, when you are exiting from an area with poor visibility. The area at the front and rear sides of the vehicles is displayed.

- ▶ Select the **B** symbol with the control knob, to see the side view in the front ⇒ *fig. 178*.
- ▶ Select the **E** symbol with the control knob, to see the side view at the rear ⇒ *fig. 179*.

### Front

Applies to vehicles: with Audi parking system plus with front- and rearview camera

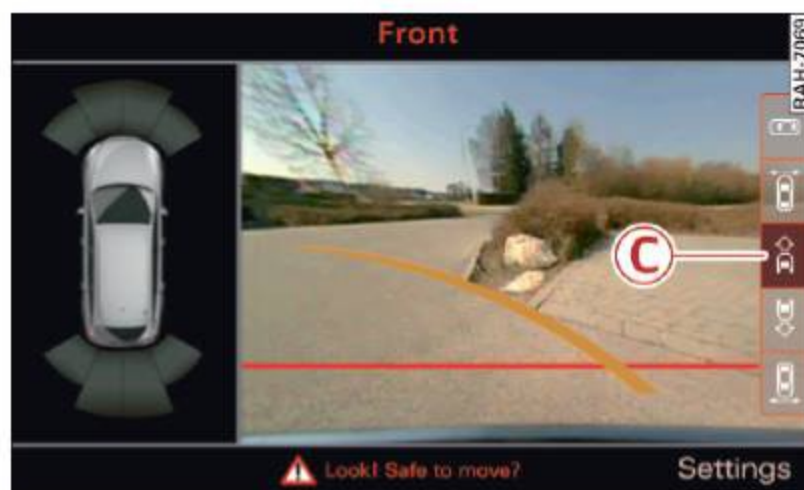

Fig. 180 MMI display: Front mode

This view assists you for example, in using the full maneuvering range in front of the vehicle. The area in front of the vehicle is displayed.

- ▶ Select the **C** symbol with the control knob. The orange colored orientation line denotes the expected direction of travel. Stop the vehicle when the red orientation line borders an obstacle ⇒ **!** in *General information on page 148*.

### Rear

Applies to vehicles: with Audi parking system plus with front- and rearview camera



Fig. 181 MMI display: Rear mode

This view assists you for example, in using the full maneuvering range behind the vehicle. The area behind the vehicle is displayed.

- ▶ Select the **D** symbol with the control knob. ▶

You can choose between three different views in this mode.

- ▶ To cross park, parallel park, or position the vehicle in front of a trailer, press the **F** control button on the controls repeatedly until the symbol for the desired mode is selected.

### Cross parking

Applies to vehicles: with Audi parking system plus with front- and rearview camera

*This view may be used when parking in a garage or in a parking space.*



Fig. 182 MMI display: Aiming at a parking space



Fig. 183 MMI display: Aligning the vehicle

Requirement: cross parking is selected  
⇒ page 150.

- ▶ The orange colored orientation lines (1) show the direction of travel of the vehicle. Turn the steering wheel until the orange orientation lines appear in the parking space ⇒ fig. 182. Use the markings (2) to help you estimate the distance from an obstacle. Each marking represents approximately 3 ft (1 m). The blue area represents an extension of the vehicle's outline by approximately 16 ft (5 m) to the rear.
- ▶ While driving in reverse gear, adjust the steering wheel angle to fit the parking space

with the aid of the orange orientation lines  
⇒ ⚠ in General information on page 148,  
⇒ ⚠ in General information on page 149.  
(3) marks the rear bumper. Stop the vehicle when the red orientation line (4) borders an obstacle ⇒ ⚠ in General Information on page 145.

### Parallel parking

Applies to vehicles: with Audi parking system plus with front- and rearview camera

*This view may be used when parallel parking along the side of a street.*



Fig. 184 MMI display: Blue surface aligned in the parking space



Fig. 185 MMI display: Contact of the blue curve with the curb

Parking on the right is described here. It is identical when parking on the left.

If there is an obstacle next to the parking space (such as a wall), refer to information for "Parking next to obstacles" ⇒ page 152.

Requirement: parallel parking is selected  
⇒ page 150.

- ▶ Activate the turn signal.
- ▶ Position your vehicle next to a parked vehicle in front of the desired parking space. The ▶

distance to this vehicle should be approximately 3 ft (1 m).

- ▶ Turn the MMI on and select the reverse gear. The parking system is turned on and the *parallel parking* indicator is displayed.
- ▶ Press the control button on the MMI controls ① ⇒ *fig. 184*. The *cross parking* indicator is displayed.
- ▶ Back up and align your vehicle so the blue area ② borders on the rear end of the vehicle or on the parking space line ⇒ ⚠ in *General information on page 148*, ⇒ ! in *General information on page 149*. The blue area represents an extension of the vehicle's outline by approximately 16 ft (5 m) to the rear. The long side of the blue area should be on the curb. The entire blue area must fit into the parking space.
- ▶ With the vehicle stopped, turn the steering wheel to the right as far as it will go.
- ▶ Back into the parking space until the blue curve ⇒ *fig. 185* touches the curb ⇒ ⚠ in *General information on page 148*, ⇒ ! in *General information on page 149*. Stop the vehicle.
- ▶ With the vehicle stopped, turn the steering wheel to the left as far as it will go.
- ▶ Continue to back into the parking space until the vehicle is parked parallel to the curb ⇒ ⚠ in *General information on page 148*, ⇒ ! in *General information on page 149*. ③ marks the rear bumper. Stop the vehicle, at the latest, when the red orientation line ④ borders an obstacle. Keep an eye on the front of your vehicle while doing this.

### Parking next to obstacles

When there is an obstacle (such as a wall) next to the parking space, choose a space with more space on the sides. Position the long side of the blue area so that there is sufficient space from the curb. The area must not be on the curb. You will also need to start turning the steering wheel much earlier. There should be a sufficient amount of space between the curb and the blue curve, and the blue curve ⇒ *fig. 185* must **not** touch the curb.

### Tips

The left or right orientation lines and surfaces will be displayed, depending on the turn signal being used.

### Trailer mode

Applies to vehicles: with Audi parking system plus with front- and rearview camera and trailer hitch

*This view assists you in positioning the vehicle in front of a trailer.*

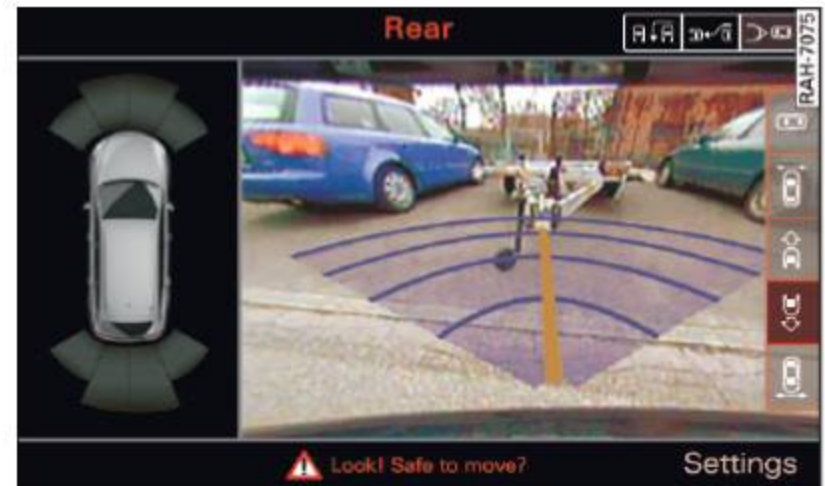

Fig. 186 MMI display: Rear mode

Requirement: the trailer mode is selected ⇒ *page 150*.

- ▶ Now you can position your vehicle in front of the trailer ⇒ ⚠ in *General information on page 148*, ⇒ ! in *General information on page 149*. The orange colored orientation line denotes the expected path toward the trailer hitch. Use the blue lines to help you estimate the distance to the trailer hitch.

### Setting the mode

Applies to vehicles: with Audi parking system plus with front- and rearview camera

- ▶ Select: **CAR** function button > **Car systems\*** control button > **Driver assist** > **Parking aid** > **Change to front/rear** > **Auto** or **Manual**.

**Auto** - This view behind the vehicle (**Rear** mode) is displayed automatically when you shift into reverse. This view in front of the vehicle (**Front** mode) is displayed automatically when you shift into the forward gears. ▶

**Manual** - This view behind the vehicle (Rear mode) is always displayed when you turn on the system.

## Adjusting the display and warning tones

Applies to vehicles: with rear park assist/Audi parking system plus with rearview camera/front- and rearview camera

*The display\* and warning tones can be adjusted in the MMI.*

- ▶ Select: **CAR** function button > **Systems\*** control button > **Parking system**. Or
- ▶ Select: **CAR** function button > **Car systems\*** control button > **Driver assist** > **Parking aid**.

### Display\*

- **Off** - when the parking system is switched off, only audible signals are given.
- **On** - when the parking system is switched on, either the visual display or the picture from the rearview camera is displayed.

### Warning tones

- **Front volume\*** - front sensor volume
- **Front frequency\*** - front sensor frequency
- **Rear volume** - rear sensor volume
- **Rear frequency** - rear sensor frequency
- **In-car entertainment fader/Music volume while parking** - when the parking system is switched on, the volume of the active audio source is lowered.

The newly adjusted value is briefly heard from the signal generator.

### Tips

- The warning tones can also be adjusted directly by the visual display\* or the picture from the camera\*. Simply press the **Settings\*** control button.
- Changed settings are activated when parking system is switched on again.
- The settings are automatically stored and assigned to the remote control key being used.

## Error messages

Applies to vehicles: with rear park assist/Audi parking system plus with rearview camera/front- and rearview camera

There is an error in the system if the LED in the **P<sub>VA</sub>** button\* is blinking and you hear a continuous alarm for a few seconds after switching on the parking system or when the parking system is already activated. If the error is not corrected before you switch off the ignition, when you switch on the parking system again, the LED in the **P<sub>VA</sub>** button\* will blink. If you activate the parking system with the button in this case, the continuous warning tone will continue to sound.

### Parking system plus with front and rearview camera\*

There is another system error if:

- the  symbol appears in the display and the corresponding display area is shown in blue. The camera is not working in this area.
- all segments around the vehicles are red or if no segments are displayed.

Drive to your authorized Audi dealer or authorized repair facility immediately to have the malfunction corrected.

## Trailer hitch

Applies to vehicles: with rear park assist/Audi parking system plus with rearview camera/front- and rearview camera and trailer hitch

For vehicles using the trailer socket, the parking system rear sensors do not turn on when you shift into reverse gear or when you press the **P<sub>VA</sub>** button\*. This results in the following restrictions:

### Rear park assist\*

There is no warning for distances to the rear.

### Audi parking system plus with rearview camera/front and rearview camera\*

There is no distance warning for the rear. The front sensors remain activated. The visual display switches to the trailer towing mode. The rearview camera image will not show the orientation lines and the blue surfaces.

 **Tips**

Trailer hitches that are not installed at the factory may cause the parking system to malfunction or they may restrict its function.

## Adaptive Air Suspension

### Air suspension and damping

#### Description

Applies to vehicles: with Adaptive Air Suspension

*Air suspension and damping can be adjusted separately.*

Adaptive Air Suspension is an electronically controlled springing and damping system. This chassis system makes it easier on the driver by adapting to the particular situation through imperceptible control processes.

The **Adaptive Air Suspension** component regulates ground clearance depending on vehicle speed and driver input. It functions independently from the load condition. Accelerating to a speed above a predetermined limit will make the vehicle lower itself. On the other hand, driving more slowly results in the vehicle raising again at specific speeds.

The **damping** component provides individual control of the damping forces. For example, with damping characteristics set to provide greater comfort, damping is set somewhat harder for a brief period only as required, for example, when going around a curve or when braking.

#### Settings

Adaptive Air Suspension provides the driver with the opportunity to set the chassis characteristics also to their individual preference. With the driving modes *Comfort*, *Automatic* and *Dynamic* the driver has three chassis settings available, ranging from comfort to sporty. The *Offroad* mode can be selected for driving on poor quality stretches of road. In addition, *Lift* provides a fifth mode, which can be selected when exceptionally high ground clearance is needed ⇒ *page 155, Chassis controls*.

The modes are set in MMI ⇒ *page 157*.

#### WARNING

The height of the parked vehicle can change due to temperature fluctuations or changes in load.

#### Note

- Whenever you park your vehicle, always make sure there is adequate clearance above and below the vehicle. The height of the parked vehicle can change as the result of temperature fluctuations, changes in load condition and changes in the driving mode (ground clearance).
- If the vehicle is being transported (e.g. by tow truck, train, ship, etc.), mount the tie-down chains/cables over the running surface (circumference) of the tires. Never secure the vehicle by the axle, the suspension struts or the front or rear tow-line eye. For technical reasons, the pressure in the suspension struts may change during the transport, which could result in the vehicle no longer being secured properly.
- If you are going to tow a trailer with a trailer hitch that was **not** installed according to factory specifications, you must activate the trailer operation mode manually ⇒ *page 159*.

#### Tips

- Before you can raise your vehicle using the vehicle jack (for example, when changing a flat tire) or a vehicle lift, you must activate the jacking mode ⇒ *page 159*.
- On some models, the vehicle can reach its maximum speed only in the *Automatic* and *Dynamic* modes.

#### Chassis controls

Applies to vehicles: with Adaptive Air Suspension

*Five different driving modes can be set by the driver.*

The automatic control processes are speed- and time-dependent. For example, it is not

possible to raise the suspension to a high level above certain speeds.

When a speed of about 75 mph (120 km/h) is exceeded for more than 30 seconds, the vehicle is automatically lowered to *low level* when in comfort and automatic mode. Ground clearance is about 0.6 inch (15 mm) less, compared to the *normal level*.

When a speed of about 100 mph (160 km/h) is exceeded for more than 20 seconds, the vehicle is automatically lowered to *highway level* when in automatic and dynamic mode. Ground clearance is about 1.4 inches (35 mm) less, compared to the *normal level*. Road holding is optimized as a result of the lower center of gravity, and fuel consumption is reduced as a result of reduced wind resistance.

| Level adjustment | Ground clearance          |
|------------------|---------------------------|
| high level 2     | about 9.4 inches (240 mm) |
| high level 1     | about 8 inches (205 mm)   |
| normal level     | about 7 inches (180 mm)   |
| low level        | about 6.5 inches (165 mm) |
| highway level    | about 5.7 inches (145 mm) |

The segment display ③ in the MMI Display ⇒ *page 157* or in the instrument cluster display ⇒ *page 158* shows the current vehicle level.

### Automatic

Select the automatic mode if you prefer a balanced, comfortable suspension setting. The damping characteristics are adjusted accordingly.

– **Automatic lowering:** When a speed of about 75 mph (120 km/h) is exceeded for more than 30 seconds, the vehicle is automatically lowered by about 0.6 inch (15 mm) to the *low level*, which is more suitable for highway speeds. Road holding is optimized as a result of the lower center of grav-

ity and fuel consumption is reduced as a result of reduced wind resistance. When a speed of about 100 mph (160 km/h) is exceeded for more than 20 seconds, the vehicle is automatically lowered by an additional 0.8 inch (20 mm) to *highway level*.

– **Automatic raising:** When the vehicle is at *highway level* and the speed falls below about 80 mph (130 km/h) for more than 20 seconds, the vehicle is automatically raised to *low level*. The vehicle is automatically raised again to *normal level* if the speed falls below about 44 mph (70 km/h) for a period of 2 minutes. The vehicle is raised immediately when speed falls below about 22 mph (35 km/h).

### Dynamic

Select the dynamic mode if you prefer a sporty suspension setting. In this mode, the vehicle is lowered to *low level* while it is still stationary and sporty damping characteristics are selected. The warning light  in the instrument cluster will come on for a few seconds just to remind you of the reduced ground clearance.

If you switch off the engine while the vehicle is in the dynamic mode and then switch on the ignition once again, the  warning light will also come on again for a few seconds as a reminder.

– **Automatic lowering:** When a speed of about 100 mph (160 km/h) is exceeded for more than 20 seconds, the vehicle is automatically lowered by 0.8 inch (20 mm) to *highway level*.

– **Automatic raising:** The vehicle is automatically raised to *low level* again, if the speed falls below about 80 mph (130 km/h) for a period of 20 seconds. The vehicle is raised immediately when speed falls below about 22 mph (35 km/h).

### Comfort

Select the comfort mode if you desire a suspension setting with a special emphasis on comfort. Damping characteristics with a clear ►

emphasis on comfort are selected in this mode.

- **Automatic lowering:** When a speed of about 75 mph (120 km/h) is exceeded for more than 30 seconds, the vehicle is automatically lowered by 0.6 inch (15 mm) to *low level*.
- **Automatic raising:** The vehicle is automatically raised to *normal level* again, if the speed falls below about 44 mph (70 km/h) for a period of 2 minutes. The vehicle is raised immediately when speed falls below about 22 mph (35 km/h).

### Offroad

Select the offroad mode when you have to travel over poor quality sections of road (e.g. trails). In this mode, the vehicle is raised to *high level 1*, and damping characteristics for poor road stretches are selected. When switching to offroad mode, the Adaptive Air Suspension indicator appears automatically in the instrument cluster display ⇒ *page 158*.

The offroad mode can only be activated at speeds below 37 mph (60 km/h). Offroad mode ends automatically and the automatic mode is activated when a speed of approximately 50 mph (80 km/h) is exceeded.

### Lift

Select the lift mode when exceptionally high ground clearance is needed at a reduced speed. In this mode, the vehicle is raised to *high level 2*. When switching to lift mode, the Adaptive Air Suspension indicator appears automatically in the instrument cluster display ⇒ *page 158*.

The lift mode can be activated only at speeds below 12 mph (20 km/h). When a speed of about 25 mph (40 km/h) is exceeded, the system automatically leaves lift mode and the offroad mode is activated. The instrument cluster display automatically switches the display to Adaptive Air Suspension to indicate reduced ground clearance.

### MMI settings

Applies to vehicles: with Adaptive Air Suspension

*Driving modes are adjusted in the MMI and the current vehicle level is displayed.*

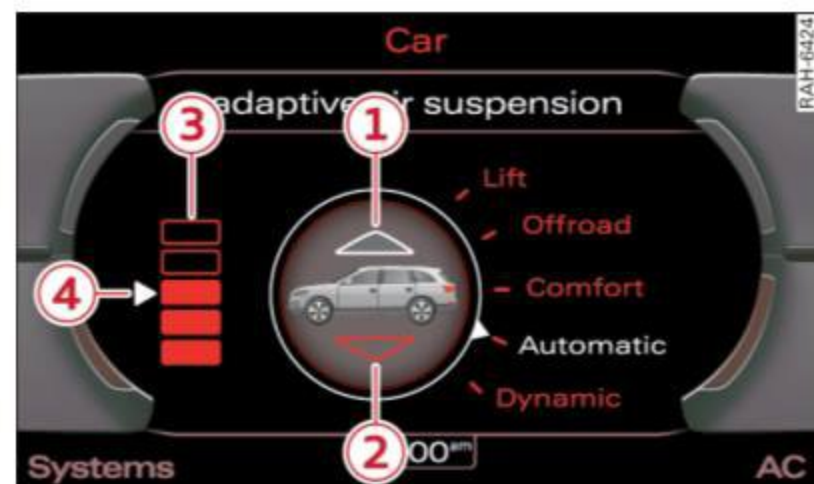

Fig. 187 MMI Display: Settings

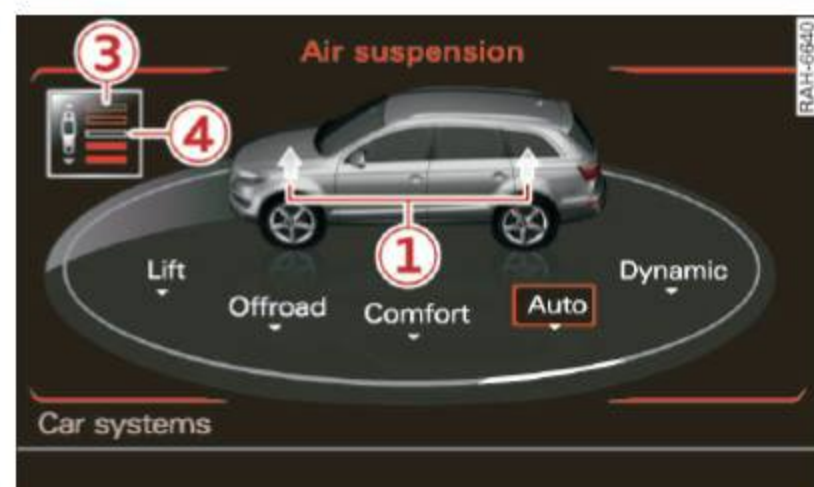

Fig. 188 MMI Display: Settings

The ignition must be switched on to set the driving modes.

- Select: **CAR** function button.

### Raising and lowering

If the arrow ① ⇒ *fig. 187* is *white* or if the arrows ① blink ⇒ *fig. 188*, the vehicle is being raised.

If the arrow ② ⇒ *fig. 187* is *white* or if the arrows ① point downward and blink ⇒ *fig. 188*, the vehicle is being lowered.

The respective arrow stays on/blinks until the level change is complete. The time used for a level change can vary, depending on the current driving conditions.

### Displaying the vehicle level

The current vehicle level is shown with segments filled out in the segment display ③. If only the bottom segment is filled out, the vehicle is at highway level. If all segments are

filled out, the vehicle is at high level 2 and has the greatest amount of ground clearance possible.

While the vehicle is being raised or lowered, the target level is indicated by an arrow **4** ⇒ *fig. 187* or a white border **4** ⇒ *fig. 188*. The arrow/border disappears again when the vehicle is at the target level.

### Limitations to MMI settings

Please note that not every driving mode can be selected in every driving situation. For example, it is not possible to switch to “lift” mode at speeds above 12 mph (20 km/h). This mode is then shown *greyed out* in the MMI Display.

The vehicle can only be lowered when **all** of the vehicle's doors are closed. If one door is open, all driving modes whose level setting is **below** the current vehicle level appear *greyed out* in the MMI Display. If a door is opened while the vehicle is being lowered, the lowering process is interrupted until all doors are closed again.

If the system is temporarily unavailable due to, for instance, an empty compressed air tank, the driving modes that cannot be set appear *greyed out* in the MMI Display. As soon as the system is available again, the driving modes can once more be selected in the display.

### **i** Tips

- For additional information on the driving modes ⇒ *page 155, Chassis controls*.
- When the compressed air tank is empty, the compressor can be switched on by starting the engine. The Adaptive Air Suspension is once again available, after waiting a few minutes.
- To prevent overload, the system switches off temporarily if several adjustments are made in a row. The Adaptive Air Suspension is once again available, after waiting a few minutes.

### Appearance in the instrument cluster display

Applies to vehicles: with Adaptive Air Suspension

You can view the current vehicle level in the instrument cluster display.

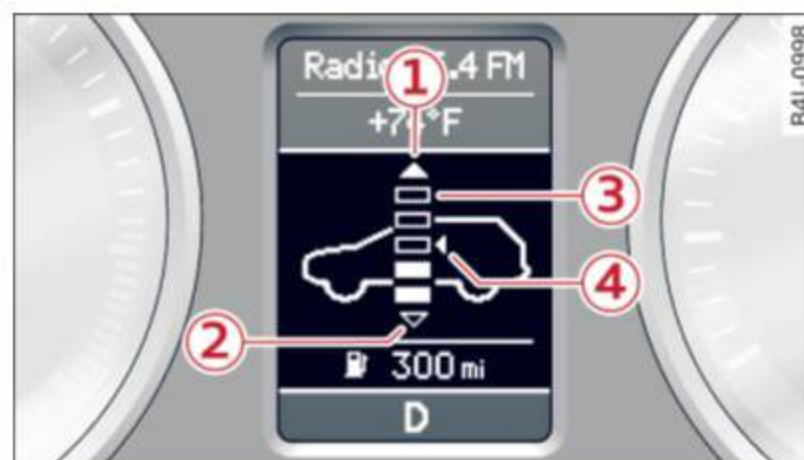

Fig. 189 Display: Adaptive Air Suspension

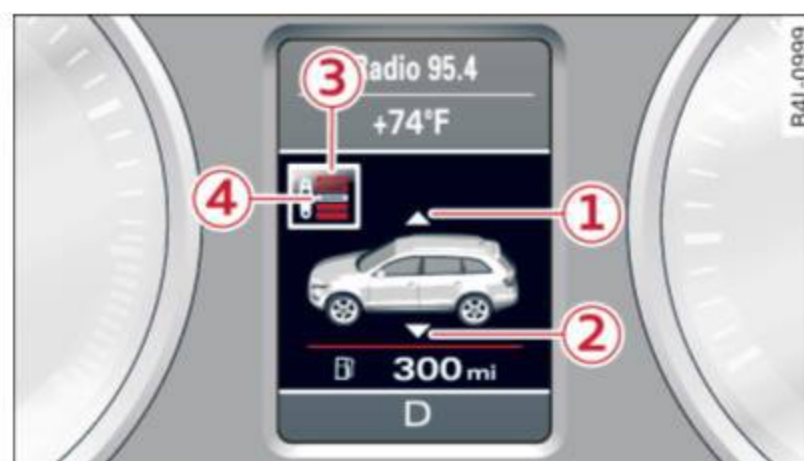

Fig. 190 Display: Adaptive Air Suspension

Repeated, brief tapping of the **RESET** button on the windshield wiper lever allows you to select whether information concerning the trip computer, digital tachometer, navigation\* or “Adaptive Air Suspension” is to appear in the instrument cluster display.

Display of the Adaptive Air Suspension is automatic when the offroad or lift mode is selected, or when the vehicle is automatically lowered in lift mode.

### Raising and lowering



If arrow **1** is white ⇒ *fig. 189* or ⇒ *fig. 190*, the vehicle is raised.

If arrow **2** is white, the vehicle is lowered.

The respective arrow stays on until the level change is complete. The time required for a level change can vary, depending on the current driving conditions.

## Displaying the vehicle level



The current vehicle level is shown with segments filled out in the segment display . If only the bottom segment is filled out, the vehicle is at highway level. If all segments are filled out, the vehicle is at high level 2 and has the greatest amount of ground clearance possible.

While the vehicle is being raised or lowered, the target level is indicated by an arrow   $\Rightarrow$  *fig. 189* or a white border   $\Rightarrow$  *fig. 190*. The arrow/border disappears again when the vehicle is at the target level.

## Jacking mode when changing a flat tire

Applies to vehicles: with Adaptive Air Suspension

*This mode must be activated in the MMI before raising the vehicle with a jack or on a vehicle lift.*

- ▶ Select:  function button >  function button > **Jacking mode**. Or
- ▶ Select:  function button > **Car systems\*** control button > **Servicing & checks** > **Air susp.: tire change**.

The vehicle jack mode must be activated before changing a wheel so that the automatic control processes for the air suspension do not make lifting with the vehicle jack more difficult.

The check lamp  in the instrument cluster display illuminates in vehicle jack mode.

### Tips

The vehicle jack mode is switched off automatically at speeds above 9 mph (15 km/h).

## Towing a trailer

Applies to vehicles: with towing hitch and Adaptive Air Suspension

*Automatic lowering is not desirable when towing a trailer.*

- ▶ Select:  function button >  function button > **Towing mode**. Or

- ▶ Select:  function button > **Car systems\*** control button > **Vehicle settings** > **Air susp.: towing**.

As long as towing mode is activated, a vehicle with a trailer appears in the **adaptive air suspension** main menu.

## Level Adjustment when towing a trailer

- Before hitching up the trailer **and** before adjusting the tongue weight at the trailer, the automatic or comfort mode **must** be selected so that the vehicle can be at normal level  $\Rightarrow$  *page 157, MMI settings*.
- If driving in dynamic mode is desired, this mode **must** be selected before hitching up the trailer and before adjusting the tongue weight. However, note that your vehicle is lowered and ground clearance is reduced.
- If you have to drive under difficult road conditions, you can select offroad or lift mode, after hitching up the trailer or after adjusting the tongue weight.
- If the vehicle is at *normal level*, and you select offroad mode while traveling at speeds higher than 22 mph (35 km/h), the vehicle will not be raised. Offroad mode will appear as the active mode in the MMI Display.
- If the vehicle is in offroad mode at *high level 1*, it automatically lowers to *normal level* when the vehicle is traveling at speeds exceeding approximately 31 mph (50 km/h). The vehicle is automatically raised to *high level 1* again when the traveling speed falls below approximately 25 mph (40 km/h).

## Restrictions when operating with a trailer

When operating with a trailer, the lift mode can only be selected up to about 12 mph (20 km/h). Lift mode is automatically canceled again when a speed of about 25 mph (40 km/h) is exceeded.

If the vehicle is in automatic, comfort, offroad or lift mode before the trailer towing mode is activated, the dynamic mode cannot be activated.

If the vehicle is in dynamic mode before towing operation is activated, it can be driven in 

this mode. If the suspension is switched from this mode to another mode, dynamic mode cannot be re-selected.

### **i** Tips

- For vehicles with a factory installed towing hitch or a trailer hitch that was installed later according to factory specifications, the system recognizes “Trailer towing mode” and activates this special mode automatically, as soon as the electrical connection on the trailer socket is connected. The mode ceases automatically when the electrical connection to the trailer socket is disconnected.
- If the trailer towing mode has been activated, the vehicle will not drop to the low or highway level.

### Cargo mode

Applies to vehicles: with Adaptive Air Suspension

*The rear of the vehicle can be lowered to make it easier to load.*



**Fig. 191** Luggage compartment detail: Cargo mode switch

### Using switch for activating cargo mode

- ▶ Close all vehicle doors.
- ▶ Open the trunk lid.
- ▶ Press the lower part of the switch **3** ⇒ *fig. 191*. The rear of the vehicle is lowered.
- ▶ Press the upper part of the switch **1**. The rear of the vehicle is raised again.

### Activating cargo mode in the MMI\*

- ▶ Select: **CAR** function button > **SETUP** function button > **Lower for loading**.

In cargo mode, the rear axle is lowered by 2.2 inches (55 mm), compared to the normal level.

While the vehicle is in cargo mode, the segments do not appear as filled in the segment display.

Cargo mode is automatically canceled again when a different mode is selected in the MMI Display, or when a speed of about 3 mph (5 km/h) has been exceeded.

If the system is temporarily unavailable due to, for instance, an empty compressed air tank, the **Lower for loading\*** function appears *greyed out* in the MMI Display. As soon as the system is available again, the function can once more be selected in the display.

While the vehicle is being lowered, the indicator light **2** ⇒ *fig. 191* on the switch in the luggage compartment flashes. When the cargo level has been reached, the indicator light comes on and remains on as long as the vehicle is in cargo mode. When the vehicle is raised again, the indicator light flashes again.

### **!** Note

Make sure before canceling cargo mode that there is sufficient clearance above the vehicle and around the trunk lid, if open.

### **i** Tips

- The vehicle will not be lowered if one of the vehicle doors is open, or if the compressed air tank is empty. The indicator light on the switch flashes three times.
- When the compressed air tank is empty, it will refill when you drive at speeds over 25 mph (40 km/h). The vehicle can be lowered to cargo level when the compressed air tank is adequately filled.
- If the vehicle is in lift or offroad mode when you activate cargo mode, the vehicle will first drop down to normal level.

## HomeLink®

### Universal remote control

#### General information

Applies to vehicles: with HomeLink® universal remote control

*The HomeLink® feature can learn up to three radio frequency codes for most current transmitters used for operating garage doors, estate gates, home or outdoor lighting systems, and other devices.*

You must first program the HomeLink® transmitter before you can use the system  
⇒ *page 162, Programming the HomeLink® transmitter.*

In order to program the HomeLink® transmitter for devices utilizing rolling code, a second person on a ladder who can safely reach the garage door opener motor is recommended. It is also necessary to locate the “learn” button on your garage door opener motor. Refer to the operating instructions for the opener, as the location and color of this button may vary by manufacturer.

You can still use the original remote control for the device at any time.

#### WARNING

- Never use the HomeLink® transmitter with any garage door opener that does not have the safety stop and reverse feature as required by federal safety standards. This includes any garage door opener model manufactured before April 1, 1982.
- A garage door opener which cannot detect an object, signaling the door to stop and reverse does not meet current federal safety standards. Using a garage door opener without these features increases risk of serious injury or death.
- For safety reasons never release the parking brake or start the engine while anyone is standing in front of the vehicle.

- A garage door or an estate gate may sometimes be set in motion when the HomeLink® remote control is being programmed. If the device is repeatedly activated, this can overstrain motor and damage its electrical components - an overheated motor is a fire hazard!
- To avoid possible injuries or property damage, please always make absolutely certain that no persons or objects are located in the range of motion of any equipment being operated.

#### Tips

- If you would like more information on HomeLink®, where to purchase the HomeLink® compatible products, or would like to purchase the HomeLink® Home Lighting Package, please call toll-free: 1-800-355-3515.
- For Declaration of Compliance to United States FCC and Industry Canada regulations ⇒ *page 328.*

## Programming the HomeLink® transmitter

Applies to vehicles: with HomeLink® universal remote control

The transmitter is programmed in two phases. For rolling code transmitters, a third phase is also necessary.

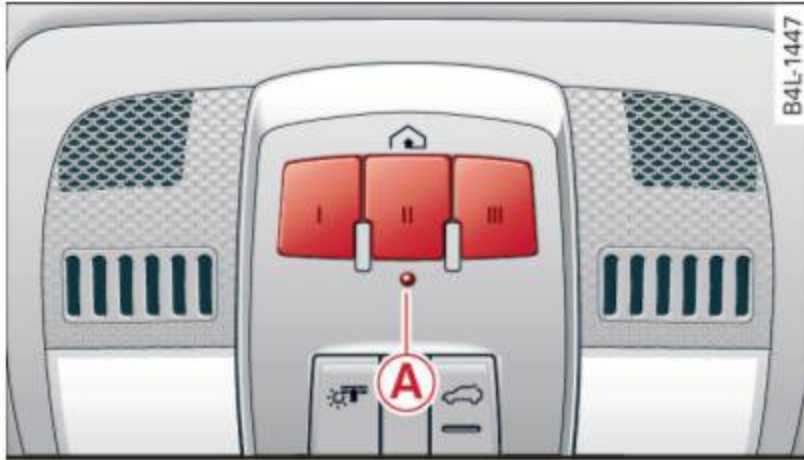

Fig. 192 Overhead console: HomeLink® keypad



Fig. 193 Front bumper, driver side: location of transmitter unit

### Phase 1: programming the overhead keypad

1. Make sure your vehicle is within operating range of the remote controlled garage door opener.
  2. Set the parking brake ⇒ ⚠ in *General information on page 161*.
  3. Turn the ignition on. Do not start the engine!
  4. Press and hold the two outside HomeLink® buttons **I** and **III** for approximately 20 seconds until indicator light **A** ⇒ *fig. 192* begins to flash. Then release both buttons. Do not hold the buttons for longer than 30 seconds.
- ▶ This procedure only needs to be performed **once**. It erases the factory-set default codes and does not have to be repeated to program additional remote controls.

5. Press and hold the HomeLink® button **I**, **II** or **III** until the indicator light **A** starts flashing *slowly*. Release the button.
- ▶ The system will remain in programming mode for 5 minutes. Go to the front of the vehicle and proceed with phase 2.

### Phase 2: programming the bumper mounted transmitter

6. Hold the *original remote control* at a distance between 0–6 in. (0–15 cm) from the bumper below the appropriate headlight for your vehicle ⇒ *fig. 193* (use the shortest distance possible).
  7. Aim the remote control just below the **driver side** headlight.
  8. Press and hold the activation button on the remote control.
- ▶ May be different in Canada. If so, press and re-press (cycle) the activation button on your remote control every two seconds.
9. The emergency flashers will flash **three times** (after about 15–60 seconds) when the programming is successful. Release the button on the remote control.
- ▶ To program more devices, repeat steps 4 to 9.
10. Press and hold the trained HomeLink® button and observe the indicator light **A** ⇒ *fig. 192*.
- ▶ If the indicator light is solid/continuous, programming is complete and your device should activate when you press and release the trained HomeLink® button.
  - ▶ If the indicator light blinks rapidly for 2 seconds and is then a solid/continuous light, proceed with phase 3 to program a rolling code device.
- ### Phase 3: rolling code programming
- ▶ A second person on a ladder who can safely reach the garage door opener motor is recommended.
11. Locate the “learn” button on the garage door opener motor (refer to the operating instructions for the opener, as the location of this button may vary by manufacturer).

12. Press and release the learn button on the garage door opener motor.
- ▶ **Note:** once the button is pressed, there are **30 seconds** in which to initiate the next step.
13. On the HomeLink® keypad inside the vehicle, firmly press and hold the HomeLink® button previously programmed in phases 1 and 2 for two seconds and release. Repeat this sequence **twice**.
- ▶ Some vehicles may require the press/hold/release sequence up to three times to complete the training process.
- ▶ HomeLink® should now activate your rolling code equipped device.

If the 5 minute time limit is exceeded, the **emergency flashers will flash one time** to indicate that the process has been terminated. In this case, repeat steps 4 through 9.

If the emergency flashers do not flash *three* times (after about 15–60 seconds), programming was not successful. In this case, repeat steps 4 through 9.

Remote control units for garage door openers in Canada are set to stop transmitting radio frequency signals after two seconds. This time may not be sufficient for the HomeLink® system to learn the radio frequency signal. Perform all other steps as described above.

### Operating the HomeLink® transmitter

Applies to vehicles: with HomeLink® universal remote control

*The HomeLink® transmitter works in the same manner as the original handheld remote control that came with the system.*



Fig. 194 Overhead console: HomeLink® keypad

- ▶ Press the appropriate programmed button **I**, **II** or **III** to activate the desired remote control function ⇒ ⚠ in *General information* on page 161.

### Reprogramming a single button

Applies to vehicles: with HomeLink® universal remote control

*A HomeLink® button can be reprogrammed individually without affecting the other button allocations.*

### Programming the overhead keypad

- ▶ Press the appropriate HomeLink® button until the indicator light begins flashing slowly.

### Programming the bumper mounted transmitter

1. Hold the *original remote control* at a distance between 0–6 in. (0–15 cm) from the bumper below the appropriate headlight for your vehicle (use the shortest distance possible).
  2. Aim the remote control just below the **driver side** headlight.
  3. Press and hold the activation button on the remote control.
  4. The emergency flashers will flash **three times** (after about 15–60 seconds) when the programming is successful. Now release the button on the remote control.
- ▶ If the device utilizes a rolling code, please follow phase 3 of ⇒ page 162, *Programming the HomeLink® transmitter* for rolling code programming.

**This procedure will cause the existing programming on the HomeLink® button to be erased!**

## Erasing the programming of the HomeLink® transmitter

Applies to vehicles: with HomeLink® universal remote control

*When you erase the programming, the programming on all three of the transmitter channels will be lost!*

- ▶ Perform steps 1 to 4 as described on  
⇒ page 162, Phase 1: programming the overhead keypad.

When completed, the HomeLink® system will be in the programming mode and is then ready to learn the codes for remote controlled devices.

### Tips

- Programmed buttons cannot be erased individually.
- For security reasons you are advised to erase the programming of the HomeLink® system before you sell your vehicle.

# Driving Safely

## General notes

### Safe driving habits

*Please remember - safety first!*

This chapter contains important information, tips, instructions and warnings that you need to read and observe for your own safety, the safety of your passengers and others. We have summarized here what you need to know about safety belts, airbags, child restraints as well as child safety. Your safety is for us *priority number 1*. Always observe the information and warnings in this section - for your own safety as well as that of your passengers.

The information in this section applies to all model versions of your vehicle. Some of the features described in this sections may be standard equipment on some models, or may be optional equipment on others. If you are not sure, ask your authorized Audi dealer.

### WARNING

- Always make sure that you follow the instructions and heed the WARNINGS in this manual. It is in your interest and in the interest of your passengers.
- Always keep all of the Owner's Literature manuals in your Audi when you lend or sell your vehicle so that this important information will always be available to the driver and passengers.
- Always keep the Owner's Literature handy so that you can find it easily if you have questions.

### Safety equipment

*The safety features are part of the occupant restraint system and work together to help reduce the risk of injury in a wide variety of accident situations.*

Your safety and the safety of your passengers should not be left to chance. Advances in technology have made a variety of features available to help reduce the risk of injury in an

accident. The following is a list of just a few of the safety features in your Audi:

- sophisticated safety belts for driver and all passenger seating positions,
- belt tensioners for the front seats and the outer seating positions in the second row seating,
- belt height adjustment for the front seats and the outer seating positions in the second row seating,
- head restraints for each seating position,
- front airbags,
- side airbags in the front seats and the outer seating positions in the second row seating\*,
- side curtain airbags,
- special LATCH anchorages for child restraints,
- adjustable steering column.

These individual safety features, can work together as a system to help protect you and your passengers in a wide range of accidents. These features cannot work as a system if they are not always correctly adjusted and correctly used.

### Safety is everybody's responsibility!

#### Important things to do before driving

*Safety is everybody's job! Vehicle and occupant safety always depends on the informed and careful driver.*

For your safety and the safety of your passengers, **before driving always:**

- ▶ Make sure that all lights and signals are operating correctly.
- ▶ Make sure that the tire pressure is correct.
- ▶ Make sure that all windows are clean and afford good visibility to the outside.
- ▶ Secure all luggage and other items carefully  
⇒ page 87.
- ▶ Make sure that nothing can interfere with the pedals.
- ▶ Adjust front seat, head restraint and mirrors correctly for your height. ▶

- ▶ Instruct passengers to adjust the head restraints according to their height.
- ▶ Make sure to use the right child restraint correctly to protect children ⇒ *page 205, Child Safety.*
- ▶ Sit properly in your seat and make sure that your passengers do the same ⇒ *page 71, General recommendations.*
- ▶ Fasten your safety belt and wear it properly. Also instruct your passengers to fasten their safety belts properly ⇒ *page 175.*

### What impairs driving safety?

Safe driving is directly related to the condition of the vehicle, the driver as well as the driver's ability to concentrate on the road without being distracted.

The driver is responsible for the safety of the vehicle and all of its occupants. If your ability to drive is impaired, safety risks for everybody in the vehicle increase and you also become a hazard to everyone else on the road ⇒ ⚠.

Therefore:

- ▶ Do not let yourself be distracted by passengers or by using a cellular telephone.
- ▶ NEVER drive when your driving ability is impaired (by medications, alcohol, drugs, etc.).
- ▶ Observe all traffic laws, rules of the road and speed limits and plain common sense.
- ▶ ALWAYS adjust your speed to road, traffic and weather conditions.
- ▶ Take frequent breaks on long trips. Do not drive for more than two hours at a stretch.
- ▶ Do NOT drive when you are tired, under pressure or when you are stressed.

### ⚠ WARNING

Impaired driving safety increases the risk of serious personal injury and death whenever a vehicle is being used.

## Proper occupant seating positions

### Proper seating position for the driver

The proper driver seating position is important for safe, relaxed driving.

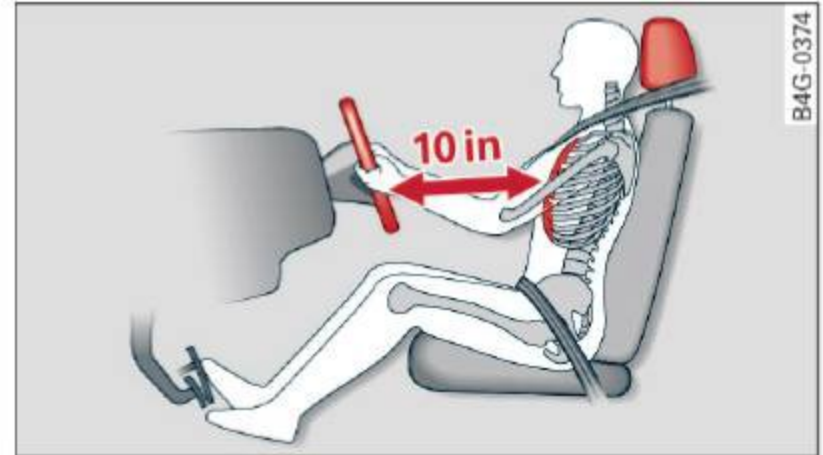

Fig. 195 Correct seating position

For your own safety and to reduce the risk of injury in the event of an accident, we recommend that you adjust the driver's seat to the following position:

- ▶ Adjust the driver's seat so that you can easily push the pedals all the way to the floor while keeping your knee(s) slightly bent ⇒ ⚠.
- ▶ Adjust the angle of the seatback so that it is in an upright position so that your back comes in full contact with it when you drive.
- ▶ Adjust the steering wheel so that there is a distance of at least 10 inches (25 cm) between the steering wheel and your breast bone ⇒ *fig. 195*. If not possible, see your authorized Audi dealer about adaptive equipment.
- ▶ Adjust the steering wheel so that the steering wheel and airbag cover points at your chest and not at your face.
- ▶ Grasp the top of the steering wheel with your elbow(s) slightly bent.
- ▶ Adjust the head restraint so the upper edge is as even as possible with the top of your head. If that is not possible, try to adjust the head restraint so that it is as close to this position as possible.
- ▶ Fasten and wear safety belts correctly ⇒ *page 179.*

- ▶ Always keep both feet in the footwell so that you are in control of the vehicle at all times.

For detailed information on how to adjust the driver's seat, see ⇒ *page 72*.

### WARNING

Drivers who are unbelted, out of position or too close to the airbag can be seriously injured by an airbag as it unfolds. To help reduce the risk of serious personal injury:

- Always adjust the driver's seat and the steering wheel so that there are at least 10 inches (25 cm) between your breastbone and the steering wheel.
- Always hold the steering wheel on the outside of the steering wheel rim with your hands at the 9 o'clock and 3 o'clock positions to help reduce the risk of personal injury if the driver's airbag inflates.
- Never hold the steering wheel at the 12 o'clock position or with your hands at other positions inside the steering wheel rim or on the steering wheel hub. Holding the steering wheel the wrong way can cause serious injuries to the hands, arms and head if the driver's airbag deploys.
- Pointing the steering wheel toward your face decreases the ability of the supplemental driver's airbag to protect you in a collision.
- Always sit in an upright position and never lean against or place any part of your body too close to the area where the airbags are located.
- Before driving, always adjust the front seats and head restraints properly and make sure that all passengers are properly restrained.
- Never adjust the seats while the vehicle is moving. Your seat may move unexpectedly and you could lose control of the vehicle.
- Never drive with the backrest reclined or tilted far back! The farther the backrests are tilted back, the greater the risk of in-

jury due to incorrect positioning of the safety belt and improper seating position.

- Children must always ride in child safety seats ⇒ *page 205*. Special precautions apply when installing a child safety seat on the front passenger seat ⇒ *page 184*.

### Proper seating position for the front passenger

*The proper front passenger seating position is important for safe, relaxed driving.*

For your own safety and to reduce the risk of injury in the event of an accident, we recommend that you adjust the seat for the front passenger to the following position:

- ▶ Adjust the angle of the seatback so that it is in an upright position and your back comes in full contact with it whenever the vehicle is moving.
- ▶ Adjust the head restraint so the upper edge is as even as possible with the top of your head. If that is not possible, try to adjust the head restraint so that it is as close to this position as possible ⇒ *page 168*.
- ▶ Keep both feet flat on the floor in front of the front passenger seat.
- ▶ Fasten and wear safety belts correctly ⇒ *page 179*.

For detailed information on how to adjust the front passenger's seat, see ⇒ *page 71*.

### WARNING

Front seat passengers who are unbelted, out of position or too close to the airbag can be seriously injured or killed by the airbag as it unfolds. To help reduce the risk of serious personal injury:

- Passengers must always sit in an upright position and never lean against or place any part of their body too close to the area where the airbags are located.
- Passengers who are unbelted, out of position or too close to the airbag can be seriously injured by an airbag as it

unfolds with great force in the blink of an eye.

- Always make sure that there are at least 10 inches (25 cm) between the front passenger's breastbone and the instrument panel.
- Each passenger must always sit on a seat of their own and properly fasten and wear the safety belt belonging to that seat.
- Before driving, always adjust the front passenger seat and head restraint properly.
- Always keep your feet on the floor in front of the seat. Never rest them on the seat, instrument panel, out of the window, etc. The airbag system and safety belt will not be able to protect you properly and can even increase the risk of injury in a crash.
- Never drive with the backrest reclined or tilted far back! The farther the backrests are tilted back, the greater the risk of injury due to incorrect positioning of the safety belt and improper seating position.
- Children must always ride in child safety seats ⇒ *page 205*. Special precautions apply when installing a child safety seat on the front passenger seat ⇒ *page 184*.

### Proper seating positions for passengers in rear seats

Rear seat passengers must sit upright with both feet on the floor consistent with their physical size and be properly restrained whenever the vehicle is in use.

To reduce the risk of injury caused by an incorrect seating position in the event of a sudden braking maneuver or an accident, your passengers on the rear bench seat must always observe the following:

- ▶ If there are passengers in the rear seat, fold the head restraints up on the occupied seats or slide the center head restraint upward at least to the next notch ⇒ *page 77*.

- ▶ Make sure that the seatback is securely latched in the upright position ⇒ *page 79*.
- ▶ Keep both feet flat in the footwell in front of the rear seat.
- ▶ Fasten and wear safety belts properly ⇒ *page 179*.
- ▶ Make sure that children are always properly restrained in a child restraint that is appropriate for their size and age ⇒ *page 205*.

### WARNING

Passengers who are improperly seated on the rear seat can be seriously injured in a crash.

- Each passenger must always sit on a seat of their own and properly fasten and wear the safety belt belonging to that seat.
- Safety belts only offer maximum protection when the seatback is securely latched in the upright position and the safety belts are properly positioned on the body. By not sitting upright, a rear seat passenger increases the risk of personal injury from improperly positioned safety belts!
- Always adjust the head restraint properly so that it can give maximum protection.

### Proper adjustment of head restraints

Correctly adjusted head restraints are an important part of your vehicle's occupant restraint system and can help to reduce the risk of injuries in accident situations.

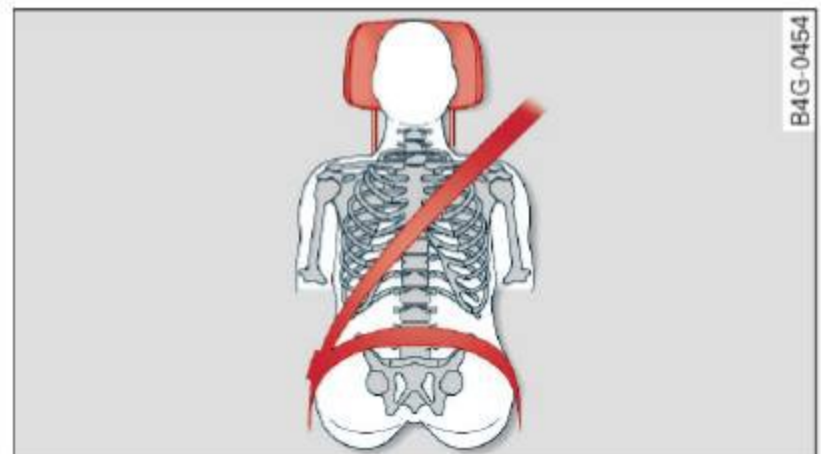

Fig. 196 Head restraint: viewed from the front

The head restraints must be correctly adjusted to achieve the best protection. ►

- ▶ Adjust the head restraints so the upper edge is as even as possible with the top of your head. If that is not possible, try to adjust the head restraint so that it is as close to this position as possible ⇒ *fig. 196*.
- ▶ If there are passengers in rear seat, fold the head restraints up on the occupied seats or slide the center head restraint upward at least to the next notch.

Adjusting head restraints ⇒ *page 76*.

### WARNING

All seats are equipped with head restraints. Driving without head restraints or with head restraints that are not properly adjusted increases the risk of serious or fatal neck injury dramatically. To help reduce the risk of injury:

- Always drive with the head restraints in place and properly adjusted.
- Every person in the vehicle must have a properly adjusted head restraint.
- Always make sure each person in the vehicle properly adjusts their head restraint. Adjust the head restraints so the upper edge is as even as possible with the top of your head. If that is not possible, try to adjust the head restraint so that it is as close to this position as possible.
- Never attempt to adjust head restraint while driving. If you have driven off and must adjust the driver headrest for any reason, first stop the vehicle safely before attempting to adjust the head restraint.
- Children must always be properly restrained in a child restraint that is appropriate for their age and size ⇒ *page 205*.

### Examples of improper seating positions

*The occupant restraint system can only reduce the risk of injury if vehicle occupants are properly seated.*

Improper seating positions can cause serious injury or death. Safety belts can only work

when they are properly positioned on the body. Improper seating positions reduce the effectiveness of safety belts and will even increase the risk of injury and death by moving the safety belt to critical areas of the body. Improper seating positions also increase the risk of serious injury and death when an airbag deploys and strikes an occupant who is not in the proper seating position. A driver is responsible for the safety of all vehicle occupants and especially for children. Therefore:

- ▶ Never allow anyone to assume an incorrect seating position when the vehicle is being used ⇒ .

The following bulletins list only some sample positions that will increase the risk of serious injury and death. Our hope is that these examples will make you more aware of seating positions that are dangerous.

### Therefore, whenever the vehicle is moving:

- never stand up in the vehicle
- never stand on the seats
- never kneel on the seats
- never ride with the seatback reclined
- never lie down on the rear seat
- never lean up against the instrument panel
- never sit on the edge of the seat
- never sit sideways
- never lean out the window
- never put your feet out the window
- never put your feet on the instrument panel
- never rest your feet on the seat cushion or back of the seat
- never ride in the footwell
- never ride in the cargo area

### WARNING

Improper seating positions increase the risk of serious personal injury and death whenever a vehicle is being used.

- Always make sure that all vehicle occupants stay in a proper seating position and are properly restrained whenever the vehicle is being used.

## Pedal area

### Pedals

*The pedals must always be free to move and must never be interfered with by a floor mat or any other object.*

Make sure that all pedals move freely without interference and that nothing prevents them from returning to their original positions.

Only use floor mats that leave the pedal area free and can be secured with floor mat fasteners.

If a brake circuit fails, increased brake pedal travel is required to bring the vehicle to a full stop.

### WARNING

Pedals that cannot move freely can cause loss of vehicle control and increase the risk of serious injury.

- Never place any objects in the driver's footwell. An object could get into the pedal area and interfere with pedal function. In case of sudden braking or an accident, you would not be able to brake or accelerate!
- Always make sure that nothing can fall or move into the driver's footwell.

### Floor mats on the driver side

*Always use floor mats that can be securely attached to the floor mat fasteners and do not interfere with the free movement of the pedals.*

- ▶ Make sure that the floor mats are properly secured and cannot move and interfere with the pedals ⇒ .

Use only floor mats that leave the pedal area unobstructed and that are firmly secured so that they cannot slip out of position. You can obtain suitable floor mats from your authorized Audi dealer.

Floor mat fasteners are installed in your Audi.

Floor mats used in your vehicle must be attached to these fasteners. Properly securing the floor mats will prevent them from sliding into positions that could interfere with the pedals or impair safe operation of your vehicle in other ways.

### WARNING

Pedals that cannot move freely can result in a loss of vehicle control and increase the risk of serious personal injury.

- Always make sure that floor mats are properly secured.
- Never place or install floor mats or other floor coverings in the vehicle that cannot be properly secured in place to prevent them from slipping and interfering with the pedals or the ability to control the vehicle.
- Never place or install floor mats or other floor coverings on top of already installed floor mats. Additional floor mats and other coverings will reduce the size of the pedal area and interfere with the pedals.
- Always properly reinstall and secure floor mats that have been taken out for cleaning.
- Always make sure that objects cannot fall into the driver footwell while the vehicle is moving. Objects can become trapped under the brake pedal and accelerator pedal causing a loss of vehicle control.

## Stowing luggage

### Loading the luggage compartment

All luggage and other objects must be properly stowed and secured in the luggage compartment.



Fig. 197 Safe load positioning: place heavy objects as low and as far forward as possible.

Loose items in the luggage compartment can shift suddenly, changing vehicle handling characteristics. Loose items can also increase the risk of serious personal injury in a sudden vehicle maneuver or in a collision.

- ▶ Distribute the load evenly in the luggage compartment.
- ▶ Always place and properly secure heavy items in the luggage compartment as low and as far forward as possible ⇒ *fig. 197*.
- ▶ Secure luggage using the tie-downs provided ⇒ *page 80*.
- ▶ Make sure that the rear seatback is securely latched in place.

### **!** WARNING

Improperly stored luggage or other items can fly through the vehicle causing serious personal injury in the event of hard braking or an accident. To help reduce the risk of serious personal injury:

- Always put objects, for example, luggage or other heavy items in the luggage compartment.
- Always secure objects in the luggage compartment using the tie-down eyelets and suitable straps.

### **!** WARNING

Heavy loads will influence the way your vehicle handles. To help reduce the risk of a loss of control leading to serious personal injury:

- Always keep in mind when transporting heavy objects, that a change in the center of gravity can also cause changes in vehicle handling:
  - Always distribute the load as evenly as possible.
  - Place heavy objects as far forward in the luggage compartment as possible.
- Never exceed the Gross Axle Weight Rating or the Gross Vehicle Weight Rating specified on the safety compliance sticker on the left door jamb. Exceeding permissible weight standards can cause the vehicle to slide and handle differently.
- Please observe information on safe driving ⇒ *page 165*.

### **!** WARNING

To help prevent poisonous exhaust gas from being drawn into the vehicle, always keep the rear lid closed while driving.

- Never transport objects larger than those fitting completely into the luggage area because the rear lid cannot be fully closed.
- If you absolutely must drive with the rear lid open, observe the following notes to reduce the risk of poisoning:
  - Close all windows,
  - Close the Panoramic sliding sunroof\*,
  - Open all air outlets in the instrument panel,
  - Switch off the air recirculation,
  - Set the fresh air fan to the highest speed.

### **!** WARNING

Always make sure that the doors, all windows, the Panoramic sliding sunroof\* and the rear lid are securely closed and locked

to reduce the risk of injury when the vehicle is not being used.

- After closing the rear lid, always make sure that it is properly closed and locked.
- Never leave your vehicle unattended especially with the rear lid left open. A child could crawl into the vehicle through the luggage compartment and close the rear lid becoming trapped and unable to get out. Being trapped in a vehicle can lead to serious personal injury.
- Never let children play in or around the vehicle.
- Never let passengers ride in the luggage compartment. Vehicle occupants must always be properly restrained in one of the vehicle's seating positions.

### **Tips**

- Air circulation helps to reduce window fogging. Stale air escapes to the outside through vents in the trim panel. Be sure to keep these slots free and open.
- The tire pressure must correspond to the load. The tire pressure is shown on the tire pressure label. The tire pressure label is located on the driver's side B-pillar. The tire pressure label lists the recommended cold tire inflation pressures for the vehicle at its maximum capacity weight and the tires that were on your vehicle at the time it was manufactured. For recommended tire pressures for normal load conditions, please see chapter [⇒ page 284](#).

### **Tie-downs**

*The luggage compartment is equipped with four tie-downs to secure luggage and other items.*

Use the tie-downs to secure your cargo properly [⇒ page 171, Loading the luggage compartment](#).

In a collision, the laws of physics mean that even smaller items that are loose in the vehicle will become heavy missiles that can cause

serious injury. Items in the vehicle possess energy which vary with vehicle speed and the weight of the item. Vehicle speed is the most significant factor.

For example, in a frontal collision at a speed of 30 mph (48 km/h), the forces acting on a 10-lb (5 kg) object are about 20 times the normal weight of the item. This means that the weight of the item would suddenly be about 200 lbs. (90 kg). You can imagine the injuries that a 200 lbs. (90 kg) item flying freely through the passenger compartment could cause in a collision like this.

### **WARNING**

Weak, damaged or improper straps used to secure items to tie-downs can fail during hard braking or in a collision and cause serious personal injury.

- Always use suitable mounting straps and properly secure items to the tie-downs in the luggage compartment to help prevent items from shifting or flying forward as dangerous missiles.
- When the rear seat backrest is folded down, always use suitable mounting straps and properly secure items to the tie-downs in the luggage compartment to help prevent items from flying forward as dangerous missiles into the passenger compartment.
- Never attach a child safety seat tether strap to a tie-down.

## **Reporting Safety Defects**

### **Applicable to U.S.A.**

If you believe that your vehicle has a defect which could cause a crash or could cause injury or death, you should immediately inform the National Highway Traffic Safety Administration 

(NHTSA) in addition to notifying Audi of America, Inc.

If NHTSA receives similar complaints, it may open an investigation, and if it finds that a safety defect exists in a group of vehicles, it may order a recall and remedy campaign. However, NHTSA cannot become involved in individual problems between you, your dealer, or Audi of America, Inc.

To contact the NHTSA, you may either call:

Tel.: 1-888-327-4236 (TTY:  
1-800-424-9153) or  
1-800-424-9393

or you may write to:

NHTSA  
U.S. Department of Transportation  
1200 New Jersey Ave., S.E.  
West Building  
Washington, DC 20590

You can also obtain other information about motor vehicle safety from:

<http://www.safercar.gov>

## Applicable to Canada

If you live in Canada and you believe that your vehicle has a defect that could cause a crash, injury or death, you should immediately inform Transport Canada, Defect Investigations and Recalls. You should also notify Volkswagen Group Canada, Inc.

Canadian customers who wish to report a safety-related defect to Transport Canada, Defect Investigations and Recalls, may either call Transport Canada toll-free at:

Tel.: 1-800-333-0510 or  
Tel.: 1-819-994-3328 (Ottawa region and from other countries)

TTY for hearing impaired:  
1-888-675-6863

or contact Transport Canada by mail at:

Transport Canada  
Motor Vehicle Safety Investigations Laboratory  
80 Noel Street  
Gatineau, QC  
J8Z 0A1

For additional road safety information, please visit the Road Safety website at:

<http://www.tc.gc.ca/eng/roadsafety/menu.htm>

## Safety belts

### General notes

#### Always wear safety belts!

*Wearing safety belts correctly saves lives!*

This chapter explains why safety belts are necessary, how they work and how to adjust and wear them correctly.

- ▶ Read all the information that follows and heed all of the instructions and WARNINGS.

#### WARNING

Not wearing safety belts or wearing them improperly increases the risk of serious personal injury and death.

- Safety belts are the single most effective means available to reduce the risk of serious injury and death in automobile accidents. For your protection and that of your passengers, always correctly wear safety belts when the vehicle is moving.
- Pregnant women, injured, or physically impaired persons must also use safety belts. Like all vehicle occupants, they are more likely to be seriously injured if they do not wear safety belts. The best way to protect a fetus is to protect the mother - throughout the entire pregnancy.

#### Number of seats

**Vehicles with five seats:** Your vehicle has two front seats and three rear seats. Each seating position has a safety belt.

**Vehicles with six seats:\*** Your vehicle has two front seats, two seats in the second row and two seats in the third row. Each seating position has a safety belt.

**Vehicles with seven seats:\*** Your vehicles has two front seats, three seats in the second row and two seats in the third row. Each seating position has a safety belt.

#### WARNING

Not wearing safety belts or wearing them improperly increases the risk of serious personal injury and death.

- Never strap more than one person, including small children, into any belt. It is especially dangerous to place a safety belt over a child sitting on your lap.
- Never let more people ride in the vehicle than there are safety belts available.
- Be sure everyone riding in the vehicle is properly restrained with a separate safety belt or child restraint.

#### Safety belt warning light

*Your vehicle has a warning system for the driver and front seat passenger (on USA models only) to remind you about the importance of buckling-up.*



Fig. 198 Safety belt warning light in the instrument cluster - enlarged

#### Before driving off, always:

- ▶ Fasten your safety belt and make sure you are wearing it properly.
- ▶ Make sure that your passengers also buckle up and properly wear their safety belts.
- ▶ Protect children with a child restraint system appropriate for the size and age.

The warning light  in the instrument cluster lights up when the ignition is switched on as a reminder to fasten the safety belts. In addition, you will hear a warning tone for a certain period of time.

**Fasten your safety belt and make sure that your passengers also properly put on their safety belts.**

**! WARNING**

- Safety belts are the single most effective means available to reduce the risk of serious injury and death in automobile accidents. For your protection and that of your passengers, always correctly wear safety belts when the vehicle is moving.
- Failure to pay attention to the warning light that come on, could lead to personal injury.

## Why safety belts?

### Frontal collisions and the law of physics

*Frontal crashes create very strong forces for people riding in vehicles.*

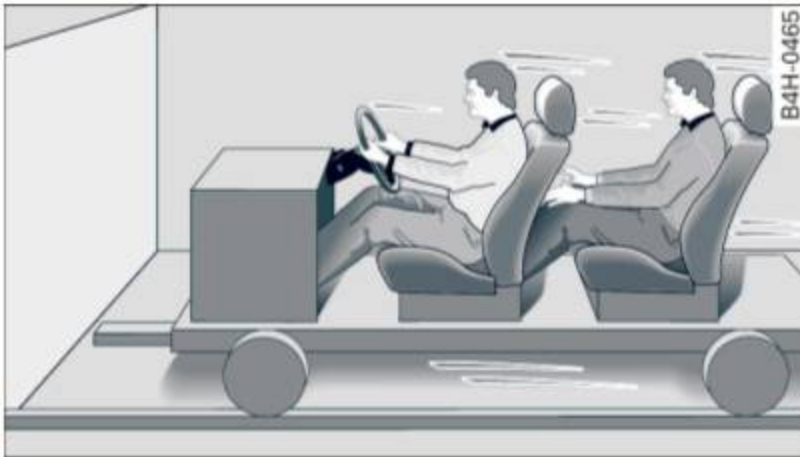

**Fig. 199** Unbelted occupants in a vehicle heading for a wall



**Fig. 200** The vehicle crashes into the wall

The physical principles are simple. Both the vehicle and the passengers possess energy which varies with vehicle speed and body weight. Engineers call this energy “kinetic energy.”

The higher the speed of the vehicle and the greater the vehicle’s weight, the more energy that has to be “absorbed” in the crash.

Vehicle speed is the most significant factor. If the speed doubles from 15 to 30 mph (25 to 50 km/h), the energy increases 4 times!

Because the passengers of this vehicle are not using safety belts ⇒ *fig. 199*, they will keep moving at the same speed the vehicle was moving just before the crash, until something stops them - here, the wall ⇒ *fig. 200*.

The same principles apply to people sitting in a vehicle that is involved in a frontal collision. Even at city speeds of 20 to 30 mph (30 to 50 km/h), the forces acting on the body can reach one ton (2,000 lbs. or 1,000 kg) or more. At greater speeds, these forces are even higher.

People who do not use safety belts are also not attached to their vehicle. In a frontal collision they will also keep moving forward at the speed their vehicle was travelling just before the crash. Of course, the laws of physics don't just apply to frontal collisions, they determine what happens in all kinds of accidents and collisions.

## What happens to occupants not wearing safety belts?

*In crashes unbelted occupants cannot stop themselves from flying forward and being injured or killed. Always wear your safety belts!*



**Fig. 201** A driver not wearing a safety belt is violently thrown forward



**Fig. 202** A rear passenger not wearing a safety belt will fly forward and strike the driver

Unbelted occupants are not able to resist the tremendous forces of impact by holding tight or bracing themselves. Without the benefit of safety restraint systems, the unrestrained occupant will slam violently into the steering wheel, instrument panel, windshield, or whatever else is in the way ⇒ *fig. 201*. This impact with the vehicle interior has all the energy they had just before the crash.

Never rely on airbags alone for protection. Even when they deploy, airbags provide only additional protection. Airbags are not supposed to deploy in all kinds of accidents. Although your Audi is equipped with airbags, all vehicle occupants, including the driver, must wear safety belts correctly in order to minimize the risk of severe injury or death in a crash.

Remember too, that airbags will deploy only once and that your safety belts are always

there to offer protection in those accidents in which airbags are not supposed to deploy or when they have already deployed. Unbelted occupants can also be thrown out of the vehicle where even more severe or fatal injuries can occur.

It is also important for the rear passengers to wear safety belts correctly. Unbelted passengers in the rear seats endanger not only themselves but also the driver and other passengers ⇒ *fig. 202*. In a frontal collision they will be thrown forward violently, where they can hit and injure the driver and/or front seat passenger.

## Safety belts protect

*People think it's possible to use the hands to brace the body in a minor collision. It's simply not true!*



**Fig. 203** Driver is correctly restrained in a sudden braking maneuver

Safety belts used properly can make a big difference. Safety belts help to keep passengers in their seats, gradually reduce energy levels applied to the body in an accident, and help prevent the uncontrolled movement that can cause serious injuries. In addition, safety belts reduce the danger of being thrown out of the vehicle.

Safety belts attach passengers to the car and give them the benefit of being slowed down more gently or “softly” through the “give” in the safety belts, crush zones and other safety features engineered into today's vehicles. By “absorbing” the kinetic energy over a longer period of time, the safety belts make the

forces on the body more “tolerable” and less likely to cause injury.

Although these examples are based on a frontal collision, safety belts can also substantially reduce the risk of injury in other kinds of crashes. So, whether you're on a long trip or just going to the corner store, always buckle up and make sure others do, too. Accident statistics show that vehicle occupants properly wearing safety belts have a lower risk of being injured and a much better chance of surviving an accident. Properly using safety belts also greatly increases the ability of the supplemental airbags to do their job in a collision. For this reason, wearing a safety belt is legally required in most countries including much of the United States and Canada.

Although your Audi is equipped with airbags, you still have to wear the safety belts provided. Front airbags, for example, are activated only in some frontal collisions. The front airbags are not activated in all frontal collisions, in side and rear collisions, in roll overs or in cases where there is not enough deceleration through impact to the front of the vehicle. The same goes for the other airbag systems in your Audi. So, always wear your safety belt and make sure everybody in your vehicle is properly restrained!

### Important safety instructions about safety belts

*Safety belts must always be correctly positioned across the strongest bones of your body.*

- ▶ Always wear safety belts as illustrated and described in this chapter.
- ▶ Make sure that your safety belts are always ready for use and are not damaged.



#### WARNING

Not wearing safety belts or wearing them improperly increases the risk of serious personal injury and death. Safety belts can work only when used correctly.

- Always fasten your safety belts correctly before driving off and make sure all passengers are correctly restrained.
- For maximum protection, safety belts must always be positioned properly on the body.
- Never strap more than one person, including small children, into any belt.
- Never place a safety belt over a child sitting on your lap.
- Always keep feet in the footwell in front of the seat while the vehicle is being driven.
- Never let any person ride with their feet on the instrument panel or sticking out the window or on the seat.
- Never remove a safety belt while the vehicle is moving. Doing so will increase your risk of being injured or killed.
- Never wear belts twisted.
- Never wear belts over rigid or breakable objects in or on your clothing, such as eye glasses, pens, keys, etc., as these may cause injury.
- Never allow safety belts to become damaged by being caught in door or seat hardware.
- Do not wear the shoulder part of the belt under your arm or otherwise out of position.
- Several layers of heavy clothing may interfere with correct positioning of belts and reduce the overall effectiveness of the system.
- Always keep belt buckles free of anything that may prevent the buckle from latching securely.
- Never use comfort clips or devices that create slack in the shoulder belt. However, special clips may be required for the proper use of some child restraint systems.
- Torn or frayed safety belts can tear, and damaged belt hardware can break in an accident. Inspect belts regularly. If webbing, bindings, buckles, or retractors are

damaged, have belts replaced by an authorized Audi dealer or qualified workshop.

- Safety belts that have been worn and loaded in an accident must be replaced with the correct replacement safety belt by an authorized Audi dealer. Replacement may be necessary even if damage cannot be clearly seen. Anchorages that were loaded must also be inspected.
- Never remove, modify, disassemble, or try to repair the safety belts yourself.
- Always keep the belts clean. Dirty belts may not work properly and can impair the function of the inertia reel  
⇒ page 254, *Safety belts*.

## Safety belts

### Fastening safety belts

*Safety first - everybody buckle up!*



**Fig. 204** Belt buckle and tongue on the driver's seat

To provide maximum protection, safety belts must always be positioned correctly on the wearer's body.

- ▶ Adjust the front seat and head restraint properly ⇒ page 71, *General recommendations*.
- ▶ Make sure the seatback of the rear seat bench is in an upright position and securely latched in place before using the belt ⇒ ⚠.
- ▶ Hold the belt by the tongue and pull it evenly across the chest and pelvis ⇒ ⚠.
- ▶ Insert the tongue into the correct buckle of your seat until you hear it latch securely ⇒ fig. 204.

- ▶ Pull on the belt to make sure that it is securely latched in the buckle.

### Automatic safety belt retractors

Every safety belt is equipped with an automatic belt retractor on the shoulder belt. This feature locks the belt when the belt is pulled out fast, during hard braking and in an accident. The belt may also lock when you drive up or down a steep hill or through a sharp curve. During normal driving the belt lets you move freely.

### Safety belt pretensioners

The safety belts are equipped with a belt pretensioner that helps to tighten the safety belt and remove slack when the pretensioner is activated. The function of the pretensioner is monitored by a warning light ⇒ page 16.

### Switchable locking feature

Every safety belt except the one on the driver seat is equipped with a switchable locking feature that **must** be used when the safety belt is used to attach a child safety seat. Be sure to read the important information about this feature ⇒ page 215.

### ⚠ WARNING

Improperly positioned safety belts can cause serious injury in an accident  
⇒ page 180, *Safety belt position*.

- Safety belts offer optimum protection only when the seatback is upright and belts are properly positioned on the body.
- Always make sure that the rear seat backrest to which the center rear safety belt is attached is securely latched whenever the rear center safety belt is being used. If the backrest is not securely latched, the passenger will move forward with the backrest during sudden braking, in a sudden maneuver and especially in a crash.
- Never attach the safety belt to the buckle for another seat. Attaching the belt to

the wrong buckle will reduce safety belt effectiveness and can cause serious personal injury.

- A passenger who is not properly restrained can be seriously injured by the safety belt itself when it moves from the stronger parts of the body into critical areas like the abdomen.
- Always lock the convertible locking retractor when you are securing a child safety seat in the vehicle ⇒ *page 217*.

### Safety belt position

*Correct belt position is the key to getting maximum protection from safety belts.*

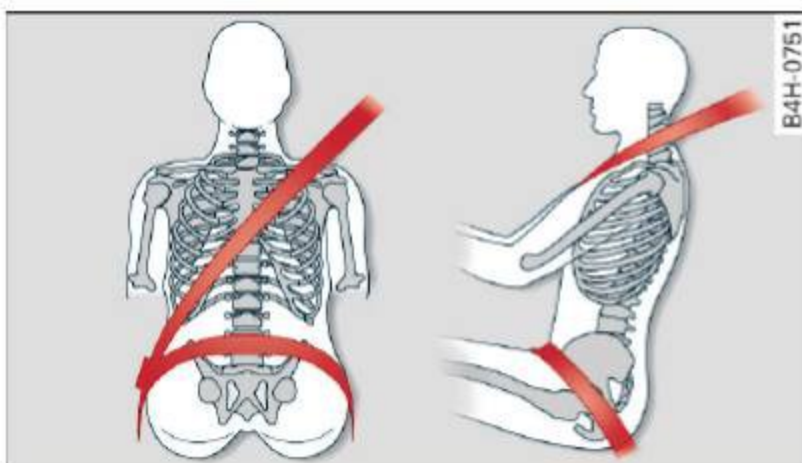

**Fig. 205** Safety belt position

Standard features on your vehicle help you adjust the position of the safety belt to match your body size.

- belt height adjustment for the front seats and the outer seating positions in the second row seating,
- height-adjustable front seats.

### WARNING

Improperly positioned safety belts can cause serious personal injury in an accident.

- The shoulder belt should lie as close to the center of the collar bone as possible and should fit well on the body. Hold the belt above the latch tongue and pull it evenly across the chest so that it sits as low as possible on the pelvis and there is no pressure on the abdomen. The belt

should always fit snugly ⇒ *fig. 205*. Pull on the belt to tighten if necessary.

- The lap belt portion of the safety belt must be positioned as low as possible across pelvis and never over the abdomen. Make sure the belt lies flat and snug ⇒ *fig. 205*. Pull on the belt to tighten if necessary.
- A loose-fitting safety belt can cause serious injuries by shifting its position on your body from the strong bones to more vulnerable, soft tissue and cause serious injury.
- Always read and heed all WARNINGS and other important information ⇒ *page 178*.

### Pregnant women must also be correctly restrained

*The best way to protect the fetus is to make sure that expectant mothers always wear safety belts correctly - throughout the pregnancy.*



**Fig. 206** Safety belt position during pregnancy

To provide maximum protection, safety belts must always be positioned correctly on the wearer's body ⇒ *page 180*.

- ▶ Adjust the front seat and head restraint correctly ⇒ *page 71, General recommendations*.
- ▶ Make sure the seatback of the rear seat bench is in an upright position and securely latched in place before using the belt.
- ▶ Hold the belt by the tongue and pull it evenly across the chest and pelvis ⇒ *fig. 206*, ⇒ .

- ▶ Insert the tongue into the correct buckle of your seat until you hear it latch securely ⇒ *page 179, fig. 204.*
- ▶ Pull on the belt to make sure that it is securely latched in the buckle.

**! WARNING**

Improperly positioned safety belts can cause serious personal injury in an accident.

- Expectant mothers must always wear the lap portion of the safety belt as low as possible across the pelvis and below the rounding of the abdomen.
- Always read and heed all WARNINGS and other important information ⇒ **!** in *Fastening safety belts on page 179.*

**Unfastening safety belts**

*Unbuckle the safety belt with the red release button only after the vehicle has stopped.*



**Fig. 207** Releasing the tongue from the buckle

- ▶ Push the red release button on the buckle ⇒ *fig. 207.* The belt tongue will spring out of the buckle ⇒ **!**
- ▶ Let the belt wind up on the retractor as you guide the belt tongue to its stowed position.

On vehicles with **third row seat\***: an unfastened safety belt can be secured in the retaining clip in the luggage compartment side trim. In this way, the luggage compartment cover can be removed without obstruction. Also, the belt tongue height can be adjusted so that luggage compartment can be loaded without obstruction with the backrest folded forward.

**! WARNING**

Never unfasten safety belt while the vehicle is moving. Doing so will increase your risk of being injured or killed.

**Adjusting safety belt height**

*With the aid of the safety belt height adjustment, the three point safety belt strap routing can be fitted to the shoulder area, according to body size.*

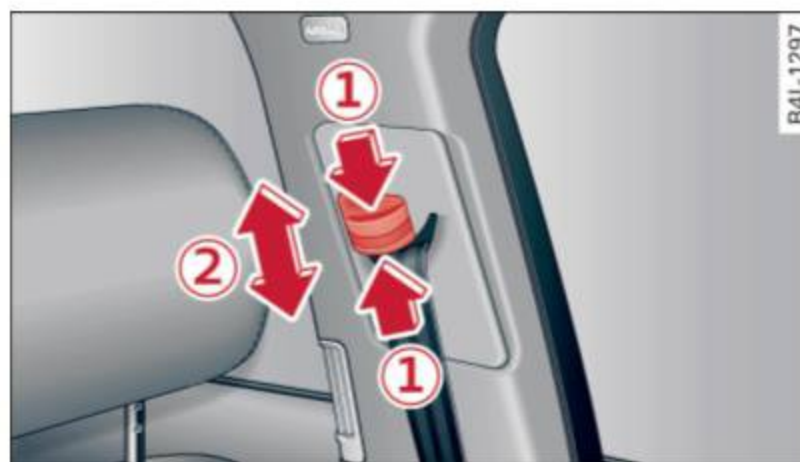

**Fig. 208** Safety belt height adjustment - loop-around fittings

The shoulder belt should lie as close to the center of the collar bone as possible and should fit well on the body ⇒ **!** in *Safety belt position on page 180.*

- ▶ Push the loop-around fittings **up** ⇒ *fig. 208* **2**, or
- ▶ squeeze together the **1** button, and push the loop-around fittings **down** **2**.
- ▶ Pull the belt to make sure that the upper attachment is properly engaged.

**! WARNING**

Always read and heed all WARNINGS and other important information ⇒ *page 178.*

**i Tips**

With the front seats, the height adjustment of the seat can also be used to adjust the position of the safety belts.

### Improperly worn safety belts

*Incorrectly positioned safety belts can cause severe injuries.*

Wearing safety belts improperly can cause serious injury or death. Safety belts can only work when they are correctly positioned on the body. Improper seating positions reduce the effectiveness of safety belts and will even increase the risk of injury and death by moving the safety belt to critical areas of the body. Improper seating positions also increase the risk of serious injury and death when an airbag deploys and strikes an occupant who is not in the correct seating position. A driver is responsible for the safety of all vehicle occupants and especially for children. Therefore:

- ▶ Never permit anyone to assume an incorrect sitting position in the vehicle while traveling ⇒ .

#### WARNING

Improperly worn safety belts increase the risk of serious personal injury and death whenever a vehicle is being used.

- Always make sure that all vehicle occupants are correctly restrained and stay in a correct seating position whenever the vehicle is being used.
- Always read and heed all WARNINGS and other important information ⇒ *page 178*.

## Safety belt pretensioners

### How safety belt pretensioners work

*In front, side and rear-end collisions above a particular severity and in a rollover, safety belts are tensioned automatically.*

The safety belts are equipped with safety belt pretensioners. The system is activated by sensors in front, side and rear-end collisions of great severity and in a rollover. This tightens the belt and takes up belt slack ⇒  *in Service*

*and disposal of safety belt pretensioner on page 183. Taking up the slack helps to reduce forward occupant movement during a collision.*

#### Note

Never let the belt remain over a rear seat-back that has been folded forward.

#### Tips

The safety belt pretensioner can only be activated once.

- In minor frontal and side collisions, in rear-end collisions and in accidents involving very little impact force, the safety belt pretensioner are not activated.
- When the safety belt pretensioners are activated, a fine dust is released. This is normal and is not caused by a fire in the vehicle.
- The relevant safety requirements must be observed when the vehicle or components of the system are scrapped. An authorized Audi dealer or qualified workshop is familiar with these regulations and will be pleased to pass on the information to you.
- Be sure to observe all safety, environmental and other regulations if the vehicle or individual parts of the system, particularly the safety belt or airbag, are to be disposed. We recommend you have your authorized Audi dealer perform this service for you.

### Service and disposal of safety belt pretensioner

The safety belt pretensioners are parts of the safety belts on your Audi. Installing, removing, servicing or repairing of belt pretensioners can damage the safety belt system and prevent it from working correctly in a collision.

There are some important things you have to know to make sure that the effectiveness of

the system will not be impaired and that discarded components do not cause injury or pollute the environment.

### **WARNING**

Improper care, servicing and repair procedures can increase the risk of personal injury and death by preventing a safety belt pretensioner from activating when needed or activating it unexpectedly:

- The belt pretensioner system can be activated only once. If belt pretensioners have been activated, the system must be replaced.
- Never repair, adjust, or change any parts of the safety belt system.
- Safety belt systems including safety belt pretensioners cannot be repaired. Special procedures are required for removal, installation and disposal of this system.
- For any work on the safety belt system, we strongly recommend that you see your authorized Audi dealer or qualified technician who has an Audi approved repair manual, training and special equipment necessary.

### **For the sake of the environment**

Undeployed airbag modules and pretensioners might be classified as Perchlorate Material -special handling may apply, see [www.dtsc.ca.gov/hazardouswaste/perchlorate](http://www.dtsc.ca.gov/hazardouswaste/perchlorate). When the vehicle or parts of the restraint system including airbag modules safety belts with pretensioners are scrapped, all applicable laws and regulations must be observed. Your authorized Audi dealer is familiar with these requirements and we recommend that you have your dealer perform this service for you.

## Airbag system

### Important things to know

#### Importance of wearing safety belts and sitting properly

*Airbags are only supplemental restraints. For airbags to do their job, occupants must always properly wear their safety belts and be in a proper seating position.*

For your safety and the safety of your passengers, before driving off, always:

- ▶ Adjust the driver's seat and steering wheel properly ⇒ *page 166*,
- ▶ Adjust the front passenger's seat properly ⇒ *page 72*,
- ▶ Wear safety belts properly ⇒ *page 178*,
- ▶ Always properly use the proper child restraint to protect children ⇒ *page 205*.

In a collision, airbags must inflate within the blink of an eye and with considerable force. The supplemental airbags can cause injuries if the driver or the front seat passenger is not seated properly. Therefore in order to help the airbag to do its job, it is important, both as a driver and as a passenger to sit properly at all times.

By keeping room between your body and the steering wheel and the front of the passenger compartment, the airbag can inflate fully and completely and provide supplemental protection in certain frontal collisions ⇒ *page 166*, *Proper occupant seating positions*. For details on the operation of the seat adjustment controls ⇒ *page 72*.

It's especially important that children are properly restrained ⇒ *page 205*.

There is a lot that the driver and the passengers can and must do to help the individual safety features installed in your Audi work together as a system.

Proper seating position is important so that the front airbag on the driver side can do its job. If you have a physical impairment or con-

dition that prevents you from sitting properly on the driver seat with the safety belt properly fastened and reaching the pedals, or if you have concerns with regard to the function or operation of the Advanced Airbag System, please contact your authorized Audi dealer or qualified workshop, or call Audi Customer Relations at 1-800-822-2834 for possible modifications to your vehicle.

When the airbag system deploys, a gas generator will fill the airbags, break open the padded covers, and inflate between the steering wheel and the driver and between the instrument panel and the front passenger. The airbags will deflate immediately after deployment so that the front occupants can see through the windshield again without interruption.

All of this takes place in the blink of an eye, so fast that many people don't even realize that the airbags have deployed. The airbags also inflate with a great deal of force and nothing should be in their way when they deploy. Front airbags in combination with properly worn safety belts slow down and limit the occupant's forward movement. Together they help to prevent the driver and front seat passenger from hitting parts of the inside of the vehicle while reducing the forces acting on the occupant during the crash. In this way they help to reduce the risk of injury to the head and upper body in the crash. Airbags do not protect the arms or the lower parts of the body.

Both front airbags will not inflate in all frontal collisions. The triggering of the airbag system depends on the vehicle deceleration rate caused by the collision and registered by the electronic control unit. If this rate is below the reference value programmed into the control unit, the airbags will not be triggered, even though the car may be badly damaged as a result of the collision. Vehicle damage, repair costs or even the lack of vehicle damage is not necessarily an indication of whether an airbag should inflate or not. ▶

Since the circumstances will vary considerably between one collision and another, it is not possible to define a range of vehicle speeds that will cover every possible kind and angle of impact that will always trigger the airbags. Important factors include, for example, the nature (hard or soft) of the object which the car hits, the angle of impact, vehicle speed, etc. The front airbags will also not inflate in side or rear collisions, or in roll-overs.

**Always remember:** Airbags will deploy only once, and only in certain kinds of collisions. Your safety belts are always there to offer protection in those situations in which airbags are not supposed to deploy, or when they have already deployed; for example, when your vehicle strikes or is struck by another vehicle after the first collision.

This is just one of the reasons why an airbag is a supplementary restraint and is not a substitute for a safety belt. The airbag system works most effectively when used with the safety belts. Therefore, always properly wear your safety belts ⇒ *page 175*.

### WARNING

- Sitting too close to the steering wheel or instrument panel will decrease the effectiveness of the airbags and will increase the risk of personal injury in a collision.
- Never sit closer than 10 inches (25 cm) to the steering wheel or instrument panel.
  - If you cannot sit more than 10 inches (25 cm) from the steering wheel, investigate whether adaptive equipment may be available to help you reach the pedals and increase your seating distance from the steering wheel.
  - If you are unrestrained, leaning forward, sitting sideways or out of position in any way, your risk of injury is much higher.
  - You will also receive serious injuries and could even be killed if you are up against the airbag or too close to it when it inflates - even with an Advanced Airbag.

- To reduce the risk of injury when an airbag inflates, always wear safety belts properly ⇒ *page 179, Safety belts*.
- Always make certain that children age 12 or younger always ride in the rear seat. If children are not properly restrained, they may be severely injured or killed when an airbag inflates.
- Never let children ride unrestrained or improperly restrained in the vehicle. Adjust the front seats properly.
- Never ride with the backrest reclined.
- Always sit as far as possible from the steering wheel or the instrument panel ⇒ *page 166*.
- Always sit upright with your back against the backrest of your seat.
- Never place your feet on the instrument panel or on the seat. Always keep both feet on the floor in front of the seat to help prevent serious injuries to the legs and hips if the airbag inflates.
- Never recline the front passenger's seat to transport objects. Items can also move into the area of the side airbag or the front airbag during braking or in a sudden maneuver. Objects near the airbags can become projectiles and cause injury when an airbag inflates.

### WARNING

- Airbags that have deployed in a crash must be replaced.
- Use only original equipment airbags approved by Audi and installed by a trained technician who has the necessary tools and diagnostic equipment to properly replace any airbag in your vehicle and assure system effectiveness in a crash.
  - Never permit salvaged or recycled airbags to be installed in your vehicle.

### Child restraints on the front seat – some important things to know

- ▶ Be sure to read the important information and heed the WARNINGS for important details about children and Advanced Airbags ⇒ *page 205*.

Even though your vehicle is equipped with an Advanced Airbag System, make certain that all children, especially those 12 years and younger, always ride in the back seat properly restrained for their age and size. The airbag on the passenger side makes the front seat a potentially dangerous place for a child to ride. The front seat is not the safest place for a child in a forward-facing child safety seat. It can be a very dangerous place for an infant or a child in a rearward-facing seat.

The Advanced Airbag System in your vehicle has been certified to comply with the requirements of United States Federal Motor Vehicle Safety Standard 208 as applicable at the time your vehicle was manufactured.

The Standard requires the front airbag on the passenger side to be turned off (“suppressed”) if a child up to about one year of age restrained in one of the rear-facing or forward-facing infant restraints listed in Federal Motor Vehicle Safety Standard 208 with which the Advanced Airbag System in your vehicle was certified has been installed on the front passenger seat. For a listing of the child restraints that were used to certify compliance with the US Safety Standard ⇒ *page 207*.

The **PASSENGER AIR BAG OFF** light in the instrument panel tells you when the front Advanced Airbag on the passenger side has been turned off by the electronic control unit.

Each time you turn on the ignition, the **PASSENGER AIR BAG OFF** light will come on for a few seconds and:

- will stay on if the front passenger seat is not occupied
- will stay on if there is a small child or child restraint on the front passenger seat

- will go off if the front passenger seat is occupied by an adult as registered by the weight-sensing mat ⇒ *page 195, Monitoring the Advanced Airbag System*.

The **PASSENGER AIR BAG OFF** light comes on when the control unit detects a total weight on the front passenger seat that requires the front airbag to be turned off.

If the total weight on the front passenger seat is more than that of a typical 1 year-old child but less than the weight of a small adult, the front airbag on the passenger side can deploy (the **PASSENGER AIR BAG OFF** light does not come on). If the **PASSENGER AIR BAG OFF** light does not come on, the front airbag on the passenger side has not been turned off by the electronic control unit and can deploy if the control unit senses an impact that meets the conditions stored in its memory.

#### For example, the airbag may deploy if:

- a small child that is heavier than a typical 1 year-old child is on the front passenger seat (regardless of whether the child is in one of the child safety seats listed ⇒ *page 207*), or
- a child who has outgrown child restraints is on the front passenger seat.

If the front passenger airbag is turned off, the **PASSENGER AIR BAG OFF** light comes on in the instrument cluster and stays on.

The front airbag on the passenger side may *not* deploy (the **PASSENGER AIR BAG OFF** light does not illuminate and stay lit) even if a small adult or teenager, or a passenger who is not sitting upright with their back against a non-reclined backrest with their feet on the vehicle floor in front of the seat is on the front passenger seat ⇒ *page 166, Proper seating position for the driver*.

If the front passenger airbag deploys, the Federal Standard requires the airbag to meet the “low risk” deployment criteria to reduce the risk of injury through interaction with the airbag. “Low risk” deployment occurs in those crashes that take place at lower decelerations ►

as defined in the electronic control unit  
 ⇒ *page 195, PASSENGER AIR BAG OFF light.*

Always remember, a child safety seat or infant carrier installed on the front seat may be struck and knocked out of position by the rapidly inflating passenger's airbag in a frontal collision. The airbag could greatly reduce the effectiveness of the child restraint and even seriously injure the child during inflation.

For this reason, and because the back seat is the safest place for children - when properly restrained according to their age and size - we strongly recommend that children always sit in the back seat ⇒ *page 205, Child Safety.*

### WARNING

A child in a rearward-facing child safety seat installed on the front passenger seat will be seriously injured and can be killed if the front airbag inflates - even with an Advanced Airbag System.

- The inflating airbag will hit the child safety seat or infant carrier with great force and will smash the child safety seat and child against the backrest, center armrest, door or roof.
- Always install rear-facing child safety seats on the rear seat.
- If you must install a rearward facing child safety seat on the front passenger seat because of exceptional circumstances and the **PASSENGER AIR BAG OFF** light does not come on and stay on, immediately install the rear-facing child safety seat in a rear seating position and have the airbag system inspected by your authorized Audi dealer.
- Forward-facing child safety seats installed on the front passenger's seat may interfere with the deployment of the airbag and cause serious personal injury to the child.

### WARNING

If, in exceptional circumstances, you must install a forward-facing child restraint on the front passenger's seat:

- Always make sure the forward-facing seat has been designed and certified by its manufacturer for use on a front seat with a passenger front and side airbag.
- Never put the forward-facing child restraint up against or very near the instrument panel.
- Always move the passenger seat into its rearmost position in the seat's fore and aft adjustment range, as far away from the airbag as possible before installing the forward-facing child restraint. The backrest must be adjusted to an upright position.
- Make sure that the **PASSENGER AIR BAG OFF** light comes on and stays on all the time whenever the ignition is switched on.

### WARNING

To reduce the risk of serious injury, make sure that the **PASSENGER AIR BAG OFF** light will be displayed whenever a child restraint is installed on the front passenger seat and the ignition is switched on.

- If the **PASSENGER AIR BAG OFF** light does not stay on, perform the checks described ⇒ *page 195, Monitoring the Advanced Airbag System.*
- Take the child restraint off the front passenger seat and install it properly at one of the rear seat positions if the **PASSENGER AIR BAG OFF** light does not stay on.
- Have the airbag system inspected by your authorized Audi dealer immediately.
- Always carefully follow instructions from child restraint manufacturers when installing child restraints.

### WARNING

If, in exceptional circumstances, you must install a forward or rearward-facing child restraint on the front passenger's seat:

- Improper installation of child restraints can reduce their effectiveness or even

prevent them from providing any protection.

- An improperly installed child restraint can interfere with the airbag as it deploys and seriously injure or even kill the child – even with an Advanced Airbag System.
- Always carefully follow the manufacturer's instructions provided with the child safety seat or carrier.
- Never place additional items on the seat that can increase the total weight registered by the weight-sensing mat and can cause injury in a crash.

## Front airbags

### Description of front airbags

*The airbag system can provide supplemental protection to properly restrained front seat occupants.*



**Fig. 209** Location of driver airbag: in steering wheel

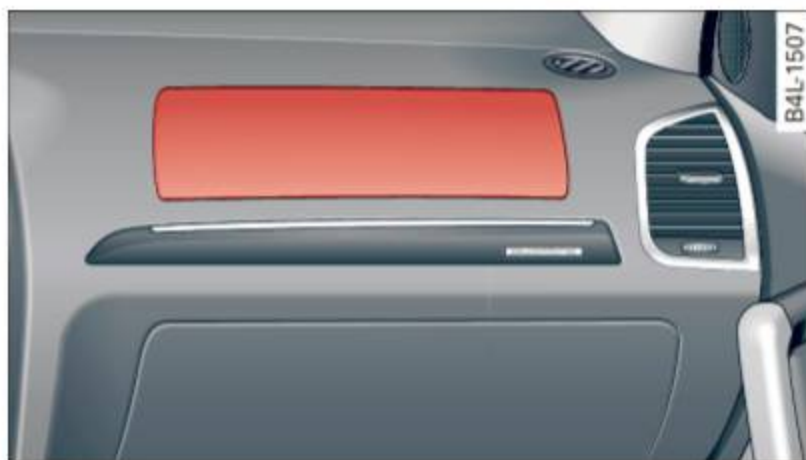

**Fig. 210** Location of front passenger's airbag: in the instrument panel

Your vehicle is equipped with an “Advanced Airbag System” in compliance with United States Federal Motor Vehicle Safety Standard (FMVSS) 208 as applicable at the time your vehicle was manufactured. The safety belts

for the seats have “pretensioners” that help to take slack out of the belt system. The pretensioners are also activated by the electronic control unit for the airbag system.

The front safety belts also have load limiters to help reduce the forces applied to the body in a crash.

The airbag for the driver is in the steering wheel hub ⇒ *fig. 209* and the airbag for the front passenger is in the instrument panel ⇒ *fig. 210*. The general location of the airbags is marked “AIRBAG”.

There is a lot you need to know about the airbags in your vehicle. We urge you to read the detailed information about airbags, safety belts and child safety in this and the other chapters that make up the owner's literature. Please be sure to heed the WARNINGS - they are extremely important for your safety and the safety of your passengers, especially infants and small children.

### WARNING

- Never rely on airbags alone for protection.
- Even when they deploy, airbags provide only supplemental protection.
  - Airbag work most effectively when used with properly worn safety belts.
  - Therefore, always wear your safety belts and make sure that everybody in your vehicle is properly restrained.

### WARNING

- A person on the front passenger seat, especially infants and small children, will receive serious injuries and can even be killed by being too close to the airbag when it inflates.
- Although the Advanced Airbag System in your vehicle is designed to turn off the front passenger airbag if an infant or a small child is on the front passenger seat, nobody can absolutely guarantee that deployment under these special

conditions is impossible in all conceivable situations that may happen during the useful life of your vehicle.

- The Advanced Airbag System can deploy in accordance with the “low risk” option under the U.S. Federal Standard if a child that is heavier than the typical one-year old child is on the front passenger seat and the other conditions for airbag deployment are met.
- Accident statistics have shown that children are generally safer in the rear seat area than in the front seating position.
- For their own safety, all children, especially 12 years and younger, should always ride in the back properly restrained for their age and size.

### Advanced front airbag system

Your vehicle is equipped with a front Advanced Airbag System in compliance with United States Federal Motor Vehicle Safety Standard 208 as applicable at the time your vehicle was manufactured.

The front Advanced Airbag System supplements the safety belts to provide additional protection for the driver's and front passenger's heads and upper bodies in frontal crashes. The airbags inflate only in frontal impacts when the vehicle deceleration is high enough.

The front Advanced Airbag System for the front seat occupants is not a substitute for your safety belts. Rather, it is part of the overall occupant restraint system in your vehicle. Always remember that the airbag system can only help to protect you, if you are sitting upright, wearing your safety belt and wearing it properly. This is why you and your passengers must always be properly restrained, not just because the law requires you to be.

The Advanced Airbag System in your vehicle has been certified to meet the “low risk” requirements for 3 and 6 year-old children on the passenger side and very small adults on the driver side. The low risk deployment criteria are intended to help reduce the risk of in-

jury through interaction with the front airbag that can occur, for example, by being too close to the steering wheel and instrument panel when the airbag inflates.

In addition, the system has been certified to comply with the “suppression” requirements of the Safety Standard, to turn off the front airbag for infants 12 months old and younger who are restrained on the front passenger seat in child restraints that are listed in the Standard ⇒ *page 207, Child restraints and Advanced Airbags.*

“Suppression” requires the front airbag on the passenger side to be turned off if:

- a child up to about one year of age is restrained on the front passenger seat in one of the rear-facing or forward-facing infant restraints listed in Federal Motor Vehicle Safety Standard 208 with which the Advanced Airbag System in your vehicle was certified. For a listing of the child restraints that were used to certify your vehicle's compliance with the US Safety Standard ⇒ *page 207,*
- weight less than a threshold level stored in the control unit is detected on the front passenger seat.

When a person is detected on the front passenger seat, weighing more than the total weight of a child that is about 1 year old restrained in one of the rear-facing or forward-facing infant restraints (listed in Federal Motor Vehicle Safety Standard 208 with which the Advanced Airbag System in your vehicle was certified), the front airbag on the passenger side may or may not deploy.

The **PASSENGER AIR BAG OFF** light comes on when the electronic control unit detects a total weight on the front passenger seat that requires the front airbag to be turned off. If the **PASSENGER AIR BAG OFF** light does not come on, the front airbag on the passenger side has not been turned off by the control unit and can deploy if the control unit senses an impact that meets the conditions stored in its memory.

If the total weight on the front passenger seat is more than that of a typical 1 year-old, but less than the weight of a small adult, the front airbag on the passenger side may deploy (the **PASSENGER AIR BAG OFF** light does not come on).

**For example, the airbag may deploy if:**

- a small child that is heavier than a typical 1 year-old child is on the front passenger seat (regardless of whether the child is in one of the child safety seats listed ⇒ *page 207*),
- a child who has outgrown child restraints is on the front passenger seat.

If the front passenger airbag is turned off, the **PASSENGER AIR BAG OFF** light in the center of the instrument panel will come on and stay on.

The front airbag on the passenger side may *not* deploy (the **PASSENGER AIR BAG OFF** light does not illuminate and stay lit) if:

- a small adult or teenager is on the front passenger seat
- a passenger who is not sitting upright with their back against a non-reclined backrest with their feet on the vehicle floor in front of the seat is on the front passenger seat.

If the front passenger airbag deploys, the Federal Standard requires the airbag to meet the “low risk” deployment criteria to help reduce the risk of injury through interaction with the airbag. “Low risk” deployment occurs in those crashes that take place at lower decelerations as defined in the electronic control unit. ⇒ *page 195*

**Always remember:** Even though your vehicle is equipped with Advanced Airbags, the safest place for children is properly restrained on the back seat. Please be sure to read the important information in the sections that follow and be sure to heed all of the WARNINGS.

 **WARNING**

To reduce the risk of injury when an airbag inflates, always wear safety belts properly.

- If you are unrestrained, leaning forward, sitting sideways or out of position in any way, your risk of injury is much higher.
- You will also receive serious injuries and could even be killed if you are up against the airbag or too close to it when it inflates - even with an Advanced Airbag ⇒ *page 184*.

 **WARNING**

A child in a rearward-facing child safety seat installed on the front passenger seat will be seriously injured and can be killed if the front airbag inflates - even with an Advanced Airbag System.

- Although the Advanced Airbag System in your vehicle is designed to turn off the front airbag when a rearward-facing child restraint has been installed on the front passenger seat, nobody can absolutely guarantee that deployment is impossible in all conceivable situations that may happen during the useful life of your vehicle.
- The inflating airbag will hit the child safety seat or infant carrier with great force and will smash the child safety seat and child against the backrest, center armrest, door, or roof.
- Always install rearward-facing child restraints on the rear seat.
- If you must install a rearward facing child safety seat on the front passenger seat because of exceptional circumstances and the **PASSENGER AIR BAG OFF** light does not come on and stay on, immediately install the rear-facing child safety seat in a rear seating position and have the airbag system inspected by your authorized Audi dealer.

 **WARNING**

If, in exceptional circumstances, you must install a forward-facing child restraint on the front passenger's seat:

- Always make sure the forward-facing seat has been designed and certified by its manufacturer for use on a front seat with a passenger front and side airbag.
- Never put the forward-facing child restraint up against or very near the instrument panel.
- Always move the passenger seat into its rearmost position in the seat's fore and aft adjustment range, as far away from the airbag as possible, before installing the forward-facing child restraint. The backrest must be adjusted to an upright position.
- Make sure that the **PASSENGER AIR BAG OFF** light comes on and stays on all the time whenever the ignition is switched on.

### Advanced Airbag System components

The front passenger seat in your vehicle has a lot of very important parts of the Advanced Airbag System in it. These parts include the weight-sensing mat, sensors, wiring, brackets, and more. The function of the system in the front passenger seat is checked by the electronic control unit when the ignition is on. The control unit monitors the Advanced Airbag System and turns the airbag indicator light on when a malfunction in the system components is detected. The function of the airbag indicator light is described in greater detail below. Because the front passenger seat contains important parts of the Advanced Airbag System, you must take care to prevent it from being damaged. Damage to the seat may prevent the Advanced Airbag for the front passenger seat from doing its job in a crash.

#### The front Advanced Airbag System consists of the following:

- Crash sensors in the front of the vehicle that measure vehicle acceleration/deceleration to provide information to the Advanced Airbag System about the severity of the crash.

- An electronic control unit, with integrated crash sensors for front and side impacts. The control unit “decides” whether to fire the front airbags based on the information received from the crash sensors. The control unit also “decides” whether the safety belt pretensioners should be activated.
- An Advanced Airbag with gas generator for the driver inside the steering wheel hub.
- An Advanced Airbag with gas generator inside the instrument panel for the front passenger.
- A weight-sensing mat under the upholstery padding of the front passenger seat cushion that measures the total weight on the seat. The information registered is sent continuously to the electronic control unit to regulate deployment of the front Advanced Airbag on the passenger side.
- An airbag monitoring system and indicator light in the instrument cluster ⇒ *page 195*.
- The **PASSENGER AIR BAG OFF** light comes on and stays on in the center of the instrument panel ⇒ *page 195, fig. 212* and tells you when the front Advanced Airbag on the passenger side has been turned off.
- A sensor below the safety belt latch for the front seat passenger to measure the tension on the safety belt. The tension on the safety belt and the weight registered by the weight-sensing mat help the control unit “decide” whether the front airbag for the front passenger seat should be turned off or not ⇒ *page 186, Child restraints on the front seat – some important things to know*.
- A sensor in the safety belt latch for the driver and for the front seat passenger that senses whether that safety belt is latched or not and transmits this information to the electronic control unit.

#### WARNING

Damage to the front passenger seat can prevent the front airbag from working properly.

- Improper repair or disassembly of the front passenger and driver seat will prevent the Advanced Airbag System from functioning properly.
- Repairs to the front passenger seat must be performed by qualified and properly trained workshop personnel.
- Never remove the front passenger or driver seat from the vehicle.
- Never remove the upholstery from the front passenger seat.
- Never disassemble or remove parts from the seat or disconnect wires from it.
- Never carry sharp objects in your pockets or place them on the seat. If the weight-sensing mat in the passenger seat is punctured it cannot work properly.
- Never carry things on your lap or carry objects on the passenger seat. Such items can increase the weight registered by the weight-sensing mat and send the wrong information to the airbag control unit.
- Never store items under the front passenger seat. Parts of the Advanced Airbag System under the passenger seat could be damaged, preventing them and the airbag system from working properly.
- Never place seat covers or replacement upholstery that have not been specifically approved by Audi on the front seats.
- Seat covers can prevent the Advanced Airbag System from recognizing child restraints or occupants on the front passenger seat and prevent the side airbag in the seat backrest from deploying properly.
- Never use cushions, pillows, blankets or similar items on the front passenger seat. The additional padding will prevent the weight-sensing mat in the seat from accurately registering the child restraint or person on the seat and prevent the Advanced Airbag System from functioning properly.
- If you must use a child restraint on the front passenger seat and the child re-

straint manufacturer's instructions require the use of a towel, foam cushion or something else to properly position the child restraint, make certain that the **PASSENGER AIR BAG OFF** light comes on and stays on whenever the child restraint is installed on the front passenger seat.

- If the **PASSENGER AIR BAG OFF** light does not come on and stay on, immediately install child restraint in a rear seating position and have the airbag system inspected by your authorized Audi dealer.

### How the Advanced Airbag System components work together

The front Advanced Airbag System and the side airbags supplement the protection offered by the front three-point safety belts with pretensioners and load limiters and the adjustable head restraints to help reduce the risk of injury in a wide range of accident and crash situations. Be sure to read the important information about safety and heed the **WARNINGS** in this chapter.

Deployment of the Advanced Airbag System and the activation of the safety belt pretensioners depend on the deceleration measured by the crash sensors and registered by the electronic control unit. Crash severity depends on speed and deceleration as well as the mass and stiffness of the vehicle or object involved in the crash.

When the electronic control unit registers a low severity crash and the safety belt is being used, the airbag will not deploy. If the safety belt is not being used, the first stage deploys, followed by the second stage after a much later time in the crash sequence.

If the electronic control unit registers a crash of medium severity, the first stage of the airbag deploys followed by the second stage at a much later time in the crash sequence - regardless of whether the safety belt is being used or not. In higher severity crashes as registered by the electronic control unit, both the ►

first and second stages deploy almost at the same time.

On the passenger side, regardless of safety belt use, the airbag will be turned off if the weight on the passenger seat is less than the amount programmed in the electronic control unit. The front airbag on the passenger side will also be turned off if one of the child safety seats that has been certified under Federal Motor Vehicle Safety Standard 208 has been recognized on the seat. The **PASSENGER AIR BAG OFF** light comes on and stays on to tell you when the front Advanced Airbag on the passenger side has been turned off

⇒ page 186, *Child restraints on the front seat – some important things to know.*

### WARNING

To reduce the risk of injury when an airbag inflates, always wear safety belts properly.

- If you are unrestrained, leaning forward, sitting sideways or out of position in any way, your risk of injury is much higher.
  - You will also receive serious injuries and could even be killed if you are up against the airbag or too close to it when it inflates - even with an Advanced Airbag
- ⇒ page 184.

### More important things to know about front airbags



Fig. 211 Inflated front airbags

Safety belts are important to help keep front seat occupants in the proper seated position so that airbags can unfold properly and provide supplemental protection in a frontal collision.

The front airbags are designed to provide additional protection for the chest and face of the driver and the front seat passenger when:

- safety belts are worn properly
- the seats have been positioned so that the occupant is properly seated as far as possible from the airbag
- and the head restraints have been properly adjusted

Because airbags inflate in the blink of an eye with great force, things you have on your lap or have placed on the seat could become dangerous projectiles, and be pushed into you if the airbag inflates.

When an airbag deploys, fine dust is released. This is normal and is not caused by a fire in the vehicle. This dust is made up mostly of a powder used to lubricate the airbags as they deploy. It could irritate skin.

It is important to remember that while the supplemental airbag system is designed to reduce the likelihood of serious injuries, other injuries, for example swelling, bruising and minor abrasions, can also happen when airbags inflate. Airbags do not protect the arms or the lower parts of the body. Front airbags supplement the three-point safety belts only in some frontal collisions in which the vehicle deceleration is high enough to deploy the airbags.

#### Front airbags will not deploy:

- if the ignition is switched off when a crash occurs
- in side collisions
- in rear-end collisions
- in rollovers
- when the crash deceleration measured by the airbag system is less than the minimum threshold needed for airbag deployment as registered by the electronic control unit

#### The front passenger airbag also will not deploy:

- when the front passenger seat is not occupied

- when the weight on the front passenger seat as sensed by the Advanced Airbag System indicates that the front airbag on the passenger side has to be turned off by the electronic control unit (the **PASSENGER AIR BAG OFF** light comes on and stays on)

 **WARNING**

Sitting in the wrong position can increase the risk of serious injury in crashes.

- To reduce the risk of injury when the airbags inflate, the driver and passengers must always sit in an upright position, must not lean against or place any part of their body too close to the area where the airbags are located.
- Occupants who are unbelted, out of position or too close to the airbag can be seriously injured by an airbag as it unfolds with great force in the blink of an eye  
⇒ *page 186.*

 **WARNING**

A child in a rearward-facing child safety seat installed on the front passenger seat will be seriously injured and can be killed if the front airbag inflates - even with an Advanced Airbag System.

- The inflating airbag will hit the child safety seat or infant carrier with great force and will smash the child safety seat and child against the backrest, center armrest, door or roof.
- Always install rear-facing child safety seats on the rear seat.
- If you must install a rearward-facing child safety seat on the front passenger seat because of exceptional circumstances and the **PASSENGER AIR BAG OFF** light does not come on and stay on, immediately install the rear-facing child safety seat in a rear seating position and have the airbag system inspected by your authorized Audi dealer.

 **WARNING**

Objects between you and the airbag will increase the risk of injury in a crash by interfering with the way the airbag unfolds or by being pushed into you as the airbag inflates.

- Never hold things in your hands or on your lap when the vehicle is in use.
- Never transport items on or in the area of the front passenger seat. Objects could move into the area of the front airbags during braking or other sudden maneuvers and become dangerous projectiles that can cause serious personal injury if the airbags inflate.
- Never place or attach accessories or other objects (such as cupholders, telephone brackets, large, heavy or bulky objects) on the doors, over or near the area marked “AIRBAG” on the steering wheel, instrument panel, seat backrests or between those areas and yourself. These objects could cause injury in a crash, especially when the airbags inflate.
- Never recline the front passenger's seat to transport objects. Items can also move into the area of the side airbag or the front airbag during braking or in a sudden maneuver. Objects near the airbags can become projectiles and cause injury, particularly when the seat is reclined.
- Never tilt the front passenger seat backrest forward when the vehicle is moving. An inflating airbag will force the backrest backward and can injure rear seat occupants.

 **WARNING**

The fine dust created when airbags deploy can cause breathing problems for people with a history of asthma or other breathing conditions.

- To reduce the risk of breathing problems, those with asthma or other respiratory conditions should get fresh air right

away by getting out of the vehicle or opening windows or doors.

- If you are in a collision in which airbags deploy, wash your hands and face with mild soap and water before eating.
- Be careful not to get the dust into your eyes, or into any cuts or scratches.
- If the residue should get into your eyes, flush them with water.

## Monitoring the Advanced Airbag System

### Airbag monitoring indicator light

Two separate indicators monitor the function of the Advanced Airbag System: the airbag monitoring indicator light and the **PASSENGER AIR BAG OFF** light.

The Advanced Airbag System (including the electronic control unit, sensor circuits and system wiring) is monitored continuously to make sure that it is functioning properly whenever the ignition is on. Each time you turn on the ignition, the airbag monitoring indicator light  will come on for a few seconds (self diagnostics).

**The system must be inspected when the indicator light :**

- does not come on when the ignition is switched on
- does not go out a few seconds after you have switched on the ignition, or
- comes on while driving

If an airbag system malfunction is detected, the indicator light will first start flashing to catch the driver's attention and then stay on continuously to serve as a constant reminder to have the system inspected immediately.

If a malfunction occurs that turns the front airbag on the passenger side off, the **PASSENGER AIR BAG OFF** light will come on and stay on whenever the ignition is on.

### WARNING

An airbag system that is not functioning properly cannot provide supplemental protection in a frontal crash.

- If the airbag indicator light comes on, it means that there may be something wrong with the Advanced Airbag System. It is possible that the airbag will inflate when it is not supposed to, or will not inflate when it should.
- Have the airbag system inspected immediately by your authorized Audi dealer.

### PASSENGER AIR BAG OFF light



Fig. 212 Section from the instrument panel: PASSENGER AIR BAG OFF light

The **PASSENGER AIR BAG OFF** light is located in the center of the instrument panel  
⇒ fig. 212.

The **PASSENGER AIR BAG OFF** light will come on and stay on to tell you when the front Advanced Airbag on the passenger side has been turned off by the electronic control unit. Each time you turn on the ignition, the **PASSENGER AIR BAG OFF** light will flash for a few seconds and:

- will stay on if the front passenger seat is not occupied
- will stay on if there is a small child or child restraint on the front passenger seat
- will go out if the front passenger seat is occupied by an adult as registered by the weight-sensing mat

The **PASSENGER AIR BAG OFF** light must come on and stay on if the ignition is on and ▶

- a car bed has been installed on the front seat, or
- a rearward-facing child restraint has been installed on the front passenger seat, or
- a forward-facing child restraint has been installed on the front passenger seat, or
- the weight registered on the front passenger seat is equal to or less than the combined weight of a typical 1 year-old restrained in one of the rear-facing or forward-facing infant restraints listed in Federal Motor Vehicle Safety Standard 208 with which the Advanced Airbag System in your vehicle was certified.

If the front passenger seat is not occupied, the front airbag will not deploy, and the **PASSENGER AIR BAG OFF** light will stay on. Never install a rearward-facing child restraint on the front passenger seat, the safest place for a child in any kind of child restraint is at one of the seating positions on the rear seat  
⇒ *page 186, Child restraints on the front seat – some important things to know* and  
⇒ *page 205, Child Safety.*

**If the PASSENGER AIR BAG OFF light comes on** when one of the conditions listed above is met, be sure to check the light regularly to make certain that the **PASSENGER AIR BAG OFF** light stays on continuously whenever the ignition is on. If the **PASSENGER AIR BAG OFF** light does not appear on and does not stay on all the time, stop as soon as it is safe to do so and

- reactivate the system by turning the ignition off and then turning it on again;
- remove and reinstall the child restraint. Make sure that the child restraint is properly installed and that the safety belt for the front passenger seat has been correctly routed through the child restraint as described in the child restraint manufacturer's instructions;
- make sure that the convertible locking feature on the safety belt for the front passenger seat has been activated and that the safety belt has been pulled tight. The belt must not be loose or have loops of slack so

that the sensor below the safety belt latch on the seat can do its job ⇒ *page 215.*

- make sure that things that may increase the weight of the child and child safety seat are not being transported on the front passenger seat;
- make sure that the safety belt tension sensor is not blocked. Shake the safety belt latch on the front passenger seatback and forth;
- If a strap or tether is being used to tie the child safety seat to the front passenger seat, make sure that it is not so tight that it causes the weight-sensing mat to measure more weight than is actually on the seat.

**If the PASSENGER AIR BAG OFF light still does not come on** and does not stay on continuously (when the ignition is switched on),

- take the child restraint off the front passenger seat and install it properly at one of the rear seat positions. Have the airbag system inspected by your authorized Audi dealer immediately.
- move the child to a rear seat position and make sure that the child is properly restrained in a child restraint that is appropriate for its size and age.

The **PASSENGER AIR BAG OFF** light should NOT come on when the ignition is on and an adult is sitting in a proper seating position on the front passenger seat. If the **PASSENGER AIR BAG OFF** light comes on and stays on or flashes for about 5 seconds while driving, under these circumstances, make sure that:

- the adult on the front passenger seat is properly seated on the center of the seat cushion with his or her back up against the backrest and the backrest is not reclined  
⇒ *page 166, Proper occupant seating positions,*
- the adult is not taking weight off the seat by holding on to the passenger assist handle above the front passenger door or supporting their weight on the armrest, ►

- the safety belt is being properly worn and that there is not a lot of slack in the safety belt webbing,
- accessory seat covers or cushions or other things that may cause an incorrect reading or impression on the weight-sensing mat under the upholstery of the seat have been removed from the front passenger seat,
- a safety belt extender has not been left in the safety belt latch for the front passenger seat.

In addition to the **PASSENGER AIR BAG OFF** light in the center of the instrument panel, the message **PASSENGER AIR BAG OFF** or **PASSENGER AIR BAG ON** will briefly appear in the instrument cluster display. This is to inform the driver of the current front passenger airbag status.

### Important safety instructions on monitoring the Advanced Airbag System

#### WARNING

An airbag system that is not functioning properly cannot provide supplemental protection in a frontal crash.

- If the airbag indicator light comes on, it means that there may be something wrong with the Advanced Airbag System. It is possible that the airbag will inflate when it is not supposed to, or will not inflate when it should.
- Have the airbag system inspected immediately by your authorized Audi dealer.

#### WARNING

If the front airbag inflates, a child without a child restraint, or in a rearward-facing child safety seat, or in a forward-facing child restraint that has not been properly installed will be seriously injured and can be killed.

- Even though your vehicle is equipped with an Advanced Airbag System, make certain that all children, especially 12 years and younger, always ride on the

back seat properly restrained for their age and size.

- Always install forward or rear-facing child safety seats on the rear seat – even with an Advanced Airbag System.
- If you must install a rearward-facing child safety seat on the front passenger seat because of exceptional circumstances and the **PASSENGER AIR BAG OFF** light does not appear and stay on, immediately install the rear-facing child safety seat in a rear seating position and have the airbag system inspected by your authorized Audi dealer.
- A tight tether or other strap on a rearward-facing child restraint attached to the front passenger seat can put too much pressure on the weight-sensing mat in the seat and register more weight than is actually on the seat. The heavier weight registered can make the system work as though an adult were on the seat and deploy the Advanced Airbag when it must be suppressed causing serious or even fatal injury to the child.
- If, in exceptional circumstances, you must install a forward-facing child restraint on the front passenger seat, always move the seat into its rearmost position in the seat's fore and aft adjustment range, as far away from the airbag as possible. The backrest must be adjusted to an upright position. Make sure that the **PASSENGER AIR BAG OFF** light comes on and stays on all the time whenever the ignition is switched on.

#### WARNING

- If the **PASSENGER AIR BAG OFF** light does not go out when an adult is sitting on the front passenger seat after taking the steps described above, make sure the adult is properly seated and restrained at one of the rear seating positions.
- Have the airbag system inspected by your authorized Audi dealer before transporting anyone on the front passenger seat.

**i Tips**

If the weight-sensing mat in the front passenger seat detects an empty seat, the front airbag on the passenger side will be turned off, and the **PASSENGER AIR BAG OFF** light will stay on.

**Repair, care and disposal of the airbags**

Parts of the airbag system are installed at many different places on your Audi. Installing, removing, servicing or repairing a part in an area of the vehicle can damage a part of an airbag system and prevent that system from working properly in a collision.

There are some important things you have to know to make sure that the effectiveness of the system will not be impaired and that discarded components do not cause injury or pollute the environment.

**! WARNING**

Improper care, servicing and repair procedures can increase the risk of personal injury and death by preventing an airbag from deploying when needed or deploying an airbag unexpectedly:

- Never cover, obstruct, or change the steering wheel horn pad or airbag cover or the instrument panel or modify them in any way.
- Never attach any objects such as cupholders or telephone mountings to the surfaces covering the airbag units.
- For cleaning the horn pad or instrument panel, use only a soft, dry cloth or one moistened with plain water. Solvents or cleaners could damage the airbag cover or change the stiffness or strength of the material so that the airbag cannot deploy and protect properly.
- Never repair, adjust, or change any parts of the airbag system.
- All work on the steering wheel, instrument panel, front seats or electrical system (including the installation of audio equipment, cellular telephones and CB

radios, etc.) must be performed by a qualified technician who has the training and special equipment necessary.

- For any work on the airbag system, we strongly recommend that you see your authorized Audi dealer or qualified workshop.
- Never modify the front bumper or parts of the vehicle body.
- Always make sure that the side airbag can inflate without interference:
  - Never install seat covers or replacement upholstery over the front seat-backs that have not been specifically approved by Audi.
  - Never use additional seat cushions that cover the areas where the side airbags inflate.
  - Damage to the original seat covers or to the seam in the area of the side airbag module must always be repaired immediately by an authorized Audi dealer.
- The airbag system can be activated only once. After an airbag has inflated, it must be replaced by an authorized Audi dealer or qualified technician who has the technical information, training and special equipment necessary.
- The airbag system can be deployed only once. After an airbag has been deployed, it must be replaced with new replacement parts designed and approved especially for your Audi model version. Replacement of complete airbag systems or airbag components must be performed by qualified workshops only. Make sure that any airbag service action is entered in your Audi Warranty & Maintenance booklet under *AIRBAG REPLACEMENT RECORD*.
- For safety reasons in severe accidents, the alternator and starter are separated from the vehicle battery with a pyrotechnic circuit interrupter.
  - Work on the pyrotechnic circuit interrupter must only be performed by a qualified dealer - risk of an accident!

- If the vehicle or the circuit interrupter is scrapped, all applicable safety precautions must be followed.

### For the sake of the environment

Undeployed airbag modules and pretensioners might be classified as Perchlorate Material - special handling may apply, see [www.dtsc.ca.gov/hazardouswaste/perchlorate](http://www.dtsc.ca.gov/hazardouswaste/perchlorate). When the vehicle or parts of the restraint system including airbag modules and safety belts with pretensioners are scrapped, all applicable laws and regulations must be observed. Your authorized Audi dealer is familiar with these requirements and we recommend that you have your dealer perform this service for you.

### Other things that can affect Advanced Airbag performance

Changing the vehicle's suspension system can change the way that the Advanced Airbag System performs in a crash. For example, using tire-rim combinations not approved by Audi, lowering the vehicle, changing the stiffness of the suspension, including the springs, suspension struts, shock absorbers etc. can change the forces that are measured by the airbag sensors and sent to the electronic control unit. Some suspension changes can, for example, increase the force levels measured by the sensors and make the airbag system deploy in crashes in which it would not deploy if the changes had not been made. Other kinds of changes may reduce the force levels measured by the sensors and prevent the airbag from deploying when it should.

The sensors in the safety belt buckle for the driver and front passenger seat tell the electronic control module if the safety belt is latched or not. If the safety belt is being used, the front airbag will deploy at a slightly higher rate of vehicle deceleration than if the safety belt is not being used. Therefore, in a particular collision, it is possible that an airbag will not deploy at a seating position where the safety belt is being used but will inflate at the

position where the safety belt is not being used. It is important that nothing interfere with the safety belt buckles so that the sensors can send the correct information about safety belt use to the electronic control unit.

### WARNING

Changing the vehicle's suspension including use of unapproved tire-rim combinations can change Advanced Airbag performance and increase the risk of serious personal injury in a crash.

- Never install suspension components that do not have the same performance characteristics as the components originally installed on your vehicle.
- Never use tire-rim combinations that have not been approved by Audi.

### WARNING

Items stored between the safety belt buckle and the center console can cause the sensors in the buckle to send the wrong information to the electronic control module and prevent the Advanced Airbag System from working properly.

- Always make sure that nothing can interfere with the safety belt buckles and that they are not obstructed.

## Side airbags

### Description of side airbags

*The airbag system can provide supplemental protection to properly restrained occupants.*



Fig. 213 Side airbag location in the driver's seat

The side airbags are located in the sides of the front seat backrests ⇒ *fig. 213* and the rear backrest\* facing the doors. They are identified by the word “AIRBAG”.

**The side airbag system basically consists of:**

- the electronic control module and external side impact sensors
- the two side airbags located in the sides of the front backrests
- two rear side airbags (as an ordered *option*)
- the airbag warning light in the instrument cluster.

The airbag system is monitored electronically to make certain that it is functioning properly at all times. Each time you turn on the ignition, the airbag system indicator light will come on for a few seconds (self diagnostics).

The side airbag system supplements the safety belts and can help to reduce the risk of injury to the driver's , front and rear\* passenger's upper torso on the side of the vehicle that is struck in a side collision. The airbag deploys only in side impacts and only when the vehicle acceleration registered by the control unit is high enough. If this rate is below the reference value programmed into the control unit, the side airbags will not be triggered, even though the car may be badly damaged as a result of the collision. It is not possible to define an airbag triggering range that will cover every possible angle of impact, since the circumstances will vary considerably between one collision and another. Important factors include, for example, the nature (hard or soft) of the impacting object, the angle of impact, vehicle speed, etc. ⇒ *page 201, Important safety instructions on the side airbag system.*

Aside from their normal safety function, safety belts work to help keep the driver or front passenger in position in the event of a side collision so that the side airbags can provide protection.

The airbag system is *not* a substitute for your safety belt. Rather, it is part of the overall occupant restraint system in your vehicle. Always remember that the side airbag system

can only help to protect you if you are wearing your safety belt and wearing it properly. This is another reason why you should always wear your safety belts, not just because the law requires you to do so ⇒ *page 175, General notes.*

It is important to remember that while the supplemental side airbag system is designed to reduce the likelihood of serious injuries, other injuries, for example, swelling, bruising, and minor abrasions can also be associated with deployed side airbags. Remember too, side airbags will deploy only once and only in certain kinds of accidents - your safety belts are always there to offer protection.

Vehicle damage, repair costs or even the lack of vehicle damage are not necessarily an indication of over-sensitive or failed airbag activation. In some collisions, both front and side airbags may inflate. Remember too, that airbags will deploy only once and only in certain kinds of collisions - your safety belts are always there to offer protection in those accidents in which airbags are not supposed to deploy or when they have already deployed.

**The side airbag system will not deploy:**

- when the ignition is turned off
- in side collisions when the acceleration measured by the sensor is too low
- in front-end collisions
- in rear-end collisions
- in rollovers.

In some types of accidents the front airbags, side curtain airbags and side airbags may be triggered together.



**WARNING**

- Safety belts and the airbag system will only provide protection when occupants are in the proper seating position ⇒ *page 201.*
- If the airbag indicator light comes on when the vehicle is being used, have the system inspected immediately by your authorized Audi dealer. The airbag may

not work properly when the vehicle acceleration in a side collision is high enough to activate the airbag.

### How supplemental side airbags work

Side airbags deploy instantly and can help reduce the risk of upper torso injuries for occupants who are properly restrained.



**Fig. 214** Inflated side airbags on left side of vehicle, rear side airbag optional equipment

When the system is triggered, the airbag is filled with propellant gas and breaks through a seam in the seat surface area marked "AIR-BAG". It expands between the side trim panel and the passenger. In order to help provide this additional protection, the side airbag must inflate within a fraction of a second at very high speed and with great force. The supplemental side airbag could injure you if your seating position is not proper or upright or if items are located in the area where the supplemental side airbag expands. This applies especially to children ⇒ *page 205, Child Safety*. Supplemental side airbags inflate between the occupant and the door panel on the side of the vehicle that is struck in certain side collision ⇒ *fig. 214*.

Although they are not a soft pillow, they can "cushion" the impact and in this way they can help to reduce the risk of injury to the upper part of the body.

A fine dust may develop when the airbag deploys. This is normal and does not mean there is a fire in the vehicle.

### Important safety instructions on the side airbag system

*Airbags are only supplemental restraints. Always properly wear safety belts and ride in a proper seating position.*

There is a lot that you and your passengers must know and act accordingly to help the safety belts and airbags do their job to provide supplemental protection.

#### WARNING

An inflating side airbag can cause serious or fatal injury. Improperly wearing safety belts and improper seating positions increase the risk of serious personal injury and death whenever a vehicle is being used.

- In order to reduce the risk of injury when the supplemental side airbag inflates:
  - Always sit in an upright position and never lean against the area where the supplemental side airbag is located.
  - Never let a child or anyone else rest their head against the side trim panel in the area where the supplemental side airbag inflates.
  - Always make sure that safety belts are worn correctly,
  - Do not let anyone sitting in the front seat put their hand or any other parts of their body out of the window.
- Always make sure that the side airbag can inflate without interference.
  - Never install seat covers or replacement upholstery over the front seat-backs that have not been specifically approved by Audi.
  - Never use additional seat cushions that cover the areas where the side airbags deploy.
  - Damage to the original seat covers or to the seam in the area of the side airbag module must always be repaired immediately by an authorized Audi dealer.

- Objects between you and the airbag can increase the risk of injury in an accident by interfering with the way the airbag unfolds or by being pushed into you as the airbag inflates.
- Never place or attach accessories or other objects (such as cupholders, telephone brackets, or even large, bulky objects) on the doors, over or near the area marked “AIRBAG” on the seat backrests.
- Such objects and accessories can become dangerous projectiles and cause injury when the supplemental side airbag deploys.
- Never carry any objects or pets in the deployment space between them and the airbags or allow children or other passengers to travel in this position.
- Always use the built-in coat hooks only for lightweight clothing. Never leave any heavy or sharp-edged objects in the pockets that may interfere with side airbag deployment and can cause personal injury in an accident.
- Always prevent the side airbags from being damaged by heavy objects knocking against or hitting the sides of the seatbacks.
- The airbag system can only be triggered once. If the airbag has been triggered, the system must be replaced by an authorized Audi dealership.
- Damage (cracks, deep scratches etc.) to the original seat covers or to the seam in the area of the side airbag module must always be repaired immediately by an authorized Audi dealer.
- If children are seated improperly, their risk of injury increases in the case of an accident ⇒ *page 205, Child Safety*.
- Never attempt to modify any components of the airbag system in any way.
- In a side collision, side airbags will not function properly if sensors cannot correctly measure increasing air pressure inside the doors when air escapes through

larger, unclosed openings in the door panel.

- Never drive with interior door trim panels removed.
- Never drive when parts have been removed from the inside door panel and the openings they leave have not been properly closed.
- Never drive when loudspeakers in the doors have been removed unless the speaker holes have been properly closed.
- Always make certain that openings are covered or filled if additional speakers or other equipment is installed in the inside door panels.
- Always have work on the doors done by an authorized Audi dealer or qualified workshop.

## Side curtain airbags

### Description of side curtain airbags

*The side curtain airbags can provide supplemental protection to properly restrained occupants.*



**Fig. 215** Side curtain airbags, driver's side: location

The side curtain airbags are located on both sides of the interior above the front and rear side windows ⇒ *fig. 215*. They are identified by the word “AIRBAG” on the windshield frame and the center roof pillar.

The side curtain airbag system supplements the safety belts and can help to reduce the risk of injury for occupants' heads and upper torso on the side of the vehicle that is struck in a side collision. The side curtain airbag

inflates in side impacts and only when the vehicle acceleration registered by the control unit is high enough. If this rate is below the reference value programmed into the control unit, the side airbags will not be triggered, even though the car may be badly damaged as a result of the collision. It is not possible to define an airbag triggering range that will cover every possible angle of impact, since the circumstances will vary considerably between one collision and another. Important factors include, for example, the nature (hard or soft) of the impacting object, the angle of impact, vehicle speed, etc. ⇒ *page 203, How side curtain airbags work.*

Aside from their normal safety function, safety belts work to help keep the driver or front passenger in position in the event of a collision so that the side curtain airbags can provide protection.

The airbag system is not a substitute for your safety belt. Rather, it is part of the overall occupant restraint system in your vehicle. Always remember that the airbag system can only help to protect you if you are wearing your safety belt and wearing it properly. This is another reason why you should always wear your safety belts, not just because the law requires you to do so ⇒ *page 175, General notes.*

It is important to remember that while the side curtain airbag system is designed to help reduce the likelihood of serious injuries, other injuries, for example, swelling, bruising, and minor abrasions can also be associated with these airbags upon deployment. Remember too, these airbags will deploy only once and only in certain kinds of accidents - your safety belts are always there to offer protection.

#### The side curtain airbag system basically consists of:

- The electronic control module and external side impact sensors
- The side curtain airbags above the front and rear side windows

- The airbag indicator light in the instrument panel

The airbag system is monitored electronically to make certain it is functioning properly at all times. Each time you turn on the ignition, the airbag system indicator light will come on for a few seconds (self diagnostics).

#### The side curtain airbag is not activated:

- if the ignition is turned off
- in side collisions when the acceleration measured by the sensor is too low
- in rear-end collisions.

#### WARNING

- Safety belts and the airbag system will only provide protection when occupants are in the proper seating position ⇒ *page 71, General recommendations.*
- If the airbag indicator light comes on when the vehicle is being used, have the system inspected immediately by your authorized Audi dealer. The side curtain airbag may not work properly even when the vehicle acceleration in a side collision is high enough to activate the airbag.

#### How side curtain airbags work

*Side curtain airbags can work together with side airbags to help reduce the risk of head and upper torso injuries for occupants who are properly restrained.*



**Fig. 216** Illustration of principle: Inflated side curtain airbags on the left side

The side curtain airbags inflate between the occupant and the windows on the side of the

vehicle that is struck in a side collision

⇒ *fig. 216.*

When the system is triggered, the side curtain airbag is filled with propellant gas and breaks through a seam above the front and rear side windows identified by the AIRBAG label. In order to help provide this additional protection, the side curtain airbag must inflate within the blink of an eye at very high speed and with great force. The side curtain airbag could injure you if your seating position is not proper or upright or if items are located in the area where the supplemental side curtain airbag inflates. This applies especially to children ⇒ *page 205.*

Although they are not a soft pillow, side curtain airbags can “cushion” the impact and in this way they can help to reduce the risk of injury to the head and the upper part of the body.

A fine dust may develop when the airbag deploys. This is quite normal and does not mean there is a fire in the vehicle.

### **Important safety instructions on the side curtain airbag system**

*Airbags are only supplemental restraints. Always properly wear safety belts and ride in a proper seating position.*

There is a lot that you and your passengers must know and do to help the safety belts and airbags do their job to provide supplemental protection.



#### **WARNING**

Improperly wearing safety belts and improper seating positions increase the risk of serious personal injury and death whenever a vehicle is being used.

- Never let occupants place any parts of their bodies in the area from which the side curtain airbags inflate.
- Always make sure that the side curtain airbags can inflate without interference. Unsuitable accessories fitted inside the

expansion range of a side curtain airbag can dangerously interfere with its function. A deploying head airbag develops enough force to catapult any piece of add-on component out of its path of inflation and into the passenger compartment. An occupant hit by such a projectile can suffer serious injury or death ⇒ *page 328, Technical Modifications.*

- Do not swivel the sun visors to the side if you have any objects clipped onto them (for example pens). If the airbag should deploy, you could be injured by these objects.
- Use the built-in coat hooks only for lightweight clothing. Never leave any heavy or sharp-edged objects in the pockets that may interfere with airbag deployment and can cause personal injury in an accident.
- Never use hangers to hang clothing from the hooks.
- Only use factory-installed sun shades or, in the case of shades installed after the vehicle leaves the factory, only Audi roll-up sunscreens may be used ⇒ *page 327, Additional accessories and parts replacement.*
- Always sit in proper seating position and wear safety belts while traveling so that the side curtain airbags can help provide protection.
- The airbag system can only be triggered once. If the airbag has been triggered, the system must be replaced by an authorized Audi dealer or qualified workshop.
- Always have work involving the side curtain airbag system, removal and installation of the airbag components, or other repairs performed by an authorized Audi dealer or qualified workshop. Otherwise the airbag system may not work correctly.
- Never attempt to modify any components of the airbag system in any way.

## Child Safety

### Important things to know

#### Introduction

*The rear seat is generally the safest place in a collision.*

The physical principles of what happens when your vehicle is in a crash apply also to children ⇒ *page 177, What happens to occupants not wearing safety belts?*. But unlike adults and teenagers, their muscles and bones are not fully developed. In many respects children are at greater risk of serious injury in crashes than adults.

Because children's bodies are not fully developed, they require restraint systems especially designed for their size, weight, and body structure. Many countries and all states of the United States and provinces of Canada have laws requiring the use of approved child restraint systems for infants and small children.

In a frontal crash at a speed of 20-35 mph (30-56 km/h) the forces acting on a 13-pound (6 kg) infant will be more than 20 times the weight of the child. This means the weight of the child would suddenly be more than 260 pounds (120 kg). Under these conditions, only an appropriate child restraint properly used can reduce the risk of serious injury. Child restraints, like adult safety belts, must be used properly to be effective. Used improperly, they can increase the risk of serious injury in an accident.

Consult the child safety seat manufacturer's instructions in order to be sure the seat is right for your child's size ⇒ *page 208, Important safety instructions for using child safety seats*. Please be sure to read and heed all of the important information and WARNINGS about child safety, Advanced Airbags, and the installation of child restraints in this chapter.

There is a lot you need to know about the Advanced Airbags in your vehicle and how they work when infants and children in child re-

straints are on the front passenger seat. Because of the large amount of important information, we cannot repeat it all here. We urge you to read the detailed information in this owner's manual about airbags and the Advanced Airbag System in your vehicle and the very important information about transporting children on the front passenger seat. Please be sure to heed the WARNINGS - they are extremely important for your safety and the safety of your passengers, especially infants and small children.

#### WARNING

- Accident statistics have shown that children are generally safer in the rear seat area than in the front seating position. Always restrain any child age 12 and under in the rear.
- All vehicle occupants and especially children must be restrained properly whenever riding in a vehicle. An unrestrained or improperly restrained child could be injured by striking the interior or by being ejected from the vehicle during a sudden maneuver or impact. An unrestrained or improperly restrained child is also at greater risk of injury or death through contact with an inflating airbag.
- A suitable child restraint properly installed and used at one of the rear seating positions provides the highest degree of protection for infants and small children in most accident situations.

#### WARNING

- Children on the front seat of any car even with Advanced Airbags can be seriously injured or even killed when an airbag inflates. A child in a rearward-facing child safety seat installed on the front passenger seat will be seriously injured and can be killed if the front airbag inflates.
- The inflating airbag will hit the child safety seat or infant carrier with great force and will smash the child safety seat and child against the backrest, center armrest, or door.

- Always install rear-facing child safety seats on the rear seat.
- If you must install a rearward facing child safety seat on the front passenger seat in exceptional circumstances and the **PASSENGER AIR BAG OFF** light does not come on and stay on, immediately install the rear-facing child safety seat in a rear seating position and have the air-bag system inspected immediately by your Audi dealer.

### **WARNING**

If, in exceptional circumstances, you must install a forward-facing child restraint on the front passenger's seat:

- Always make sure the forward-facing seat has been designed and certified by its manufacturer for use on a front seat with a passenger front and side airbag.
- Always follow the manufacturer's instructions provided with the child safety seat or carrier.
- Always move the passenger seat into its rearmost position in the seat's fore and aft adjustment range, as far away from the airbag as possible before installing the child restraint. The backrest must be adjusted to an upright position.
- Always make sure that the **PASSENGER AIR BAG OFF** light comes on and stays on all the time whenever the ignition is switched on.

### **Tips**

Always replace child restraints that were installed in a vehicle during a crash. Damage to a child restraint that is not visible could cause it to fail in another collision situation.

### **Advanced front airbag system and children**

Your vehicle is equipped with an “Advanced Airbag System” in compliance with United States Federal Motor Vehicle Safety Standard

(FMVSS) 208 as applicable at the time your vehicle was manufactured.

The Advanced Airbag system in your vehicle has been certified to meet the “low-risk” requirements for 3- and 6-year old children on the passenger side and small adults on the driver side. The low risk deployment criteria are intended to reduce the risk of injury through interaction with the airbag that can occur, for example, by being too close to the steering wheel and instrument panel when the airbag inflates. In addition, the system has been certified to comply with the “suppression” requirements of the Safety Standard, to turn off the front airbag for infants up to 12 months who are restrained on the front passenger seat in child restraints that are listed in the Standard.

Even though your vehicle is equipped with an Advanced Airbag system, all children, especially those 12 years and younger, should always ride in the back seat properly restrained for their age and size. The airbag on the passenger side makes the front seat a potentially dangerous place for a child to ride. The front seat is not the safest place for a child in a forward-facing child safety seat. It can be a very dangerous place for an infant or a larger child in a rearward-facing seat.

### **Advanced Airbags and the weight-sensing mat in the front seat**

The Advanced Airbag System in your vehicle detects the presence of an infant or child in a child restraint on the front passenger seat using the weight-sensing mat in the seat cushion and the sensor below the safety belt latch on the front passenger seat that measures the tension on the safety belt.

The weight-sensing mat measures total weight of the child and the child safety seat and a child blanket on the front passenger seat. The weight on the front passenger seat is related to the design of the child restraint and its “footprint”, the size and shape of the bottom of the child restraint as it sits on the

seat. The weight of a child restraint and its “footprint” vary for different kinds of child restraints and for the different models of the same kind of child restraint offered by child restraint manufacturers.

The weight ranges for the individual types, makes and models of child restraints that the NHTSA has specified in the Safety Standard together with the weight ranges of typical infants and typical 1 year-old child have been stored in the control unit of the Advanced Airbag System. When a child restraint is being used on the front passenger seat with a typical 1 year-old child, the Advanced Airbag System compares the weight measured by the weight sensing mat with the information stored in the electronic control unit.

The electronic control unit also registers the tension on the front passenger safety belt. The tension on the safety belt for the front passenger seat will be different for an adult who is properly using the safety belt as compared to the tension on the belt when it is used to attach a child restraint to the seat. The sensor below the latch for the safety belt for the front seat passenger measures the tension on the belt. The input from this sensor is then used with the weight to “decide”, whether there is a child restraint with a typical 1 year-old child on the front passenger seat and whether or not the airbag must be turned off.

**Child restraints and Advanced Airbags**

Regardless of the child restraint that you use, make sure that it has been certified to meet United States Federal Motor Vehicle Safety Standards and has been certified by its manufacturer for use with an airbag. Always be sure that the child restraint is properly installed at one of the rear seating positions. If in exceptional circumstances you must use it on the front passenger seat, carefully read all of the information on child safety and Advanced Airbags and heed all of the applicable WARNINGS. Make certain that the child restraint is correctly recognized by the weight-sensing

mat inside the front passenger seat, that the front passenger airbag is turned off and that the airbag status is always correctly signaled by the **PASSENGER AIR BAG OFF** light.

Many types and models of child restraints have been available over the years, new models are introduced regularly incorporating new and improved designs and older models are taken out of production. Child restraints are not standardized. Child restraints of the same type typically have different weights and sizes and different 'footprints,' the size and shape of the bottom of the child restraint that sits on the seat, when they are installed on a vehicle seat. These differences make it virtually impossible to certify compliance with the requirements for advanced airbags with each and every child restraint that has ever been sold in the past or will be sold over the course of the useful life of your vehicle.

For this reason, the United States National Highway Traffic Safety Administration has published a list of specific type, makes and models of child restraints that must be used to certify compliance of the Advanced Airbag System in your vehicle with the suppression requirements of Federal Motor Vehicle Safety Standard 208. These child restraints are:

**Subpart A – Car bed child restraints**

| Model                            | Manufactured on or after |
|----------------------------------|--------------------------|
| Angel Guard Angel Ride AA2403FOF | September 25, 2007       |

**Subpart B – Rear-facing child restraints**

| Model                                     | Manufactured on or after |
|---|--------------------------|
| Century SmartFit 4543                     | December 1, 1999         |
| Cosco Arriva 22-013PAW and base 22-999WHO | September 25, 2007       |
| Evenflo Discovery Adjust Right 212        | December 1, 1999         |

Controls and equipment

Safety first

Vehicle operation

Vehicle care

Do-it-yourself service

Technical data

| Model                                 | Manufactured on or after |
|---------------------------------------|--------------------------|
| Evenflo First Choice 204              | December 1, 1999         |
| Graco Infant 8457                     | December 1, 1999         |
| Graco Snugride                        | September 25, 2007       |
| Peg Perego Primo Viaggio SIP IMUN00US | September 25, 2007       |

### Subpart C – Forward-facing and convertible child restraints

| Model  | Manufactured on or after |
|--|--------------------------|
| Britax Roundabout E9L02xx                    | September 25, 2007       |
| Cosco Touriva 02519                          | December 1, 1999         |
| Cosco Summit Deluxe High Back Booster 22-262 | September 25, 2007       |
| Cosco High Back Booster 22-209               | September 25, 2007       |
| Evenflo Tribute V 379xxxx                    | September 25, 2007       |
| Evenflo Medallion 254                        | December 1, 1999         |
| Evenflo Generations 352xxxx                  | September 25, 2007       |
| Graco ComfortSport                           | September 25, 2007       |
| Graco Toddler Safety Seat Step 2             | September 25, 2007       |
| Graco Platinum Cargo                         | September 25, 2007       |

#### **WARNING**

To reduce the risk of serious injury, make sure that the **PASSENGER AIR BAG OFF** light comes on and stays on whenever a child restraint is installed on the front passenger seat and the ignition is switched on.

- Take the child restraint off the front passenger seat and install it properly at one of the rear seat positions if the **PASSENGER AIR BAG OFF** light does not stay on.

- Have the airbag system inspected by your authorized Audi dealer immediately.

#### **Tips**

The child seats listed in categories A to C have been statically tested by Audi only for the Advanced Airbag function.

### Important safety instructions for using child safety seats

*Correct use of child safety seats substantially reduces the risk of injury in an accident!*

As the driver, you are responsible for the safety of everybody in the vehicle, especially children:

- ▶ Always use the right child safety seat for each child and always use it properly ⇒ *page 211*.
- ▶ Always carefully follow the child safety seat manufacturer's instructions on how to route the safety belt properly through the child safety seat.
- ▶ When using the vehicle safety belt to install a child safety seat, you must first activate the convertible locking retractor on the safety belt to prevent the child safety seat from moving ⇒ *page 215*.
- ▶ Push the child safety seat down with your full weight to get the safety belt really tight so that the seat cannot move forward or sideways more than one inch (2.5 cm).
- ▶ If a strap or tether is being used to tie the child safety seat to the front passenger seat, make sure that it is not so tight that it causes the weight-sensing mat to measure more weight than is actually on the seat.
- ▶ Secure unused safety belts on the rear seat ⇒ *page 210*.

Always remember: Even though your vehicle is equipped with an Advanced Airbag system, all children, especially those 12 years and younger, should always ride in the back seat properly restrained for their age and size. ▶

**! WARNING**

Not using a child safety seat, using the wrong child safety seat or improperly installing a child restraint increases the risk of serious personal injury and death.

- All vehicle occupants and especially children must always be restrained properly whenever riding in a vehicle.
  - An unrestrained or improperly restrained child can be injured or killed by being thrown against the inside of the vehicle or by being ejected from it during a sudden maneuver or impact.
  - An unrestrained or improperly restrained child is at much greater risk of injury or death by being struck by an inflating airbag.
- Commercially available child safety seats are required to comply with U.S. Federal Motor Vehicle Safety Standard (FMVSS) 213 (in Canada CMVSS 213).
  - When buying a child restraint, select one that fits your child and the vehicle.
  - Only use child restraint systems that fully contact the flat portion of the seat cushion. The child restraint must not tip or lean to either side. Audi does not recommend using child safety seats that rest on legs or tube-like frames. They do not provide adequate contact with the seat.
  - Always heed all legal requirements pertaining to the installation and use of child safety seats and carefully follow the instructions provided by the manufacturer of the seat you are using.
- Never allow children under 57 inches (1.45 meters) to wear a normal safety belt. They must always be restrained by a proper child restraint system. Otherwise, they could sustain injuries to the abdomen and neck areas during sudden braking maneuvers or accidents.
- Never let more than one child occupy a child safety seat.

- Never let babies or older children ride in a vehicle while sitting on the lap of another passenger.
  - Holding a child in your arms is never a substitute for a child restraint system.
  - The strongest person could not hold the child with the forces that exist in an accident. The child will strike the interior of the vehicle and can also be struck by the passenger.
  - The child and the passenger can also injure each other in an accident.
- Never install rear-facing child safety seats or infant carriers on the front passenger seat. A child will be seriously injured and can be killed when the passenger airbag inflates – even with an Advanced Airbag System.
- The inflating airbag will hit the child safety seat or infant carrier with great force and will smash the child safety seat and child against the backrest, center armrest, door or roof.
- Always install rear-facing child safety seats or infant carriers on the rear seat.
- Forward-facing child safety seats installed on the front passenger's seat can interfere with the airbag when it inflates and cause serious injury to the child. Always install forward-facing child safety seats on the rear seat.
- If exceptional circumstances require the use of a forward-facing child restraint on the front passenger's seat, the child's safety and well-being require that the following special precautions be taken:
  - Make sure the forward-facing seat has been designed and certified by its manufacturer for use on a front seat with a passenger front and side airbag.
  - Always carefully follow the manufacturer's instructions provided with the child safety seat or carrier.
  - Always move the front passenger seat into the rearmost position of the passenger seat's fore and aft adjustment range, and as far away from the airbag

as possible before installing the child restraint.

- Always make sure that nothing prevents the front passenger's seat from being moved to the rearmost position in its fore and aft adjustment range.
- Always make sure that the backrest is in the upright position.
- Always buckle the child safety seat firmly in place even if a child is not sitting in it. A loose child safety seat can fly around during a sudden stop or in a collision.
- Always read and heed all WARNINGS whenever using a child restrained in a vehicle is being used ⇒ *page 175, Safety belts*, ⇒ *page 184, Airbag system* and ⇒ *page 205, Child Safety*.

### WARNING

- To reduce the risk of serious injury, make sure that the **PASSENGER AIR BAG OFF** light comes on and stays on whenever a child restraint is installed on the front passenger seat and the ignition is switched on.
- Take the child restraint off the front passenger seat and install it properly at one of the rear seat positions if the **PASSENGER AIR BAG OFF** light does not stay on.
  - Have the airbag system inspected by your authorized Audi dealer immediately.

### Secure unused safety belts on the rear seat



**Fig. 217** Schematic overview: keep unused safety belts away from children in child safety seats. **A** - outer rear safety belt, **B** - center rear safety belt

If a child safety seat is used on the rear bench, especially with LATCH universal lower anchorages, the unused safety belts **must** be secured so that the child in the child restraint cannot reach them ⇒ .

- Guide the safety belt webbing behind the head restraint of the adjacent seat ⇒ *fig. 217*. When doing so, do not engage the switchable locking retractor! You should not hear a “clicking” sound when winding up the safety belt.
- Let the belt retractor wind up the safety belt webbing.

### WARNING

- A child in a child safety seat installed with the LATCH lower anchorages or with the standard safety belt or a child in a booster seat on the rear seat could play with unused rear seat safety belts and become entangled. This could cause the child serious personal injury and even death.
- Always secure unused rear seat safety belts out of reach of children in child seats such as by properly routing them around the head restraint of the seat where the child restraint is installed.
  - Never activate the switchable locking retractor when routing the safety belts around the head restraints.
  - Never let anyone sit at the center rear seating position if the center rear safety belt has been routed around a rear head restraint.

## Child safety seats

### Infant seats

Babies and infants up to about one year old and 20 lbs. or 9 kg need special rearward-facing child restraints that support the back, neck and head in a crash.

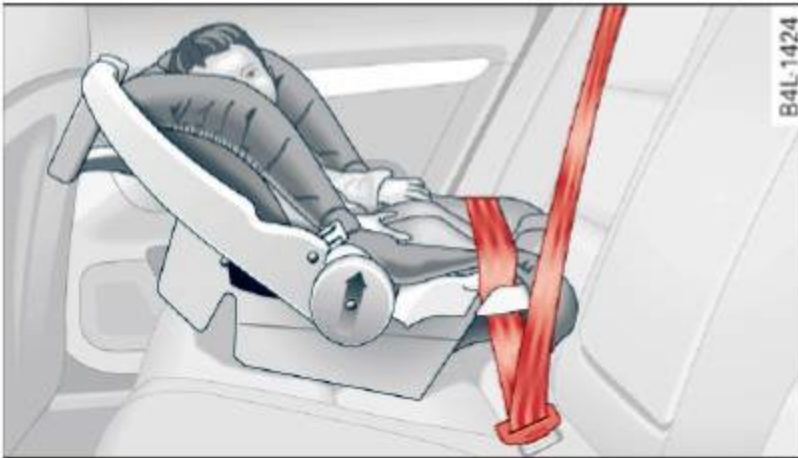

**Fig. 218** Schematic overview: rearward-facing infant seat, properly installed on the rear seat

- ▶ When using the vehicle safety belt to install a child safety seat, you must first activate the convertible locking retractor on the safety belt to prevent the child safety seat from moving ⇒ *page 215* or install the seat using the LATCH attachments.
- ▶ Push the child safety seat down with your full weight to get the safety belt really tight so that the seat cannot move forward or sideways more than one inch (2.5 cm).
- ▶ Secure unused safety belts on the rear seat ⇒ *page 210*.

Infants up to about one year (20 lbs. or 9 kg) are best protected in special infant carriers and child safety seats designed for their age group. Many experts believe that infants and small children should ride only in special restraints in which the child faces the back of the vehicle. These infant seats support the baby's back, neck and head in a crash ⇒ *fig. 218*.

The airbag on the passenger side makes the front seat a potentially dangerous place for a child to ride. The front seat is not the safest place for a child in a forward-facing child seat. It is a very dangerous place for an infant or a larger child in a rearward-facing seat.

### WARNING

Not using a child safety seat, using the wrong child safety seat or improperly installing a child restraint increases the risk of serious personal injury and death in a crash.

- Never install rear-facing child safety seats or infant carriers on the front passenger seat - even with an Advanced Airbag System. A child will be seriously injured and can be killed when the inflating airbag hits the child safety seat or infant carrier with great force and smashes the child safety seat and child against the backrest, center armrest, door or roof ⇒ *page 186, Child restraints on the front seat - some important things to know*.
- Always install rear-facing child safety seats or infant carriers on the rear seat.
- Never install a rear-facing child restraint in the forward-facing direction. Such restraints are designed for the special needs of infants and very small children and cannot protect them properly if the seat is forward-facing.
- If you must install a rearward facing child safety seat on the front passenger seat because of exceptional circumstances and the **PASSENGER AIR BAG OFF** light does not come on and stay on, immediately install the rear-facing child safety seat in a rear seating position and have the airbag system inspected by your Audi dealer.
- Always read and heed all WARNINGS whenever using a child restrained in a vehicle is being used ⇒ *page 175, Safety belts*, ⇒ *page 184, Airbag system* and ⇒ *page 205, Important things to know*.

### Convertible child safety seats

Properly used convertible child safety seats can help protect toddlers and children over age one who weigh between 20 and 40 lbs. (9 and 18 kg) in a crash.



**Fig. 219** Schematic overview: installation of the attachments applicable to a LATCH seat

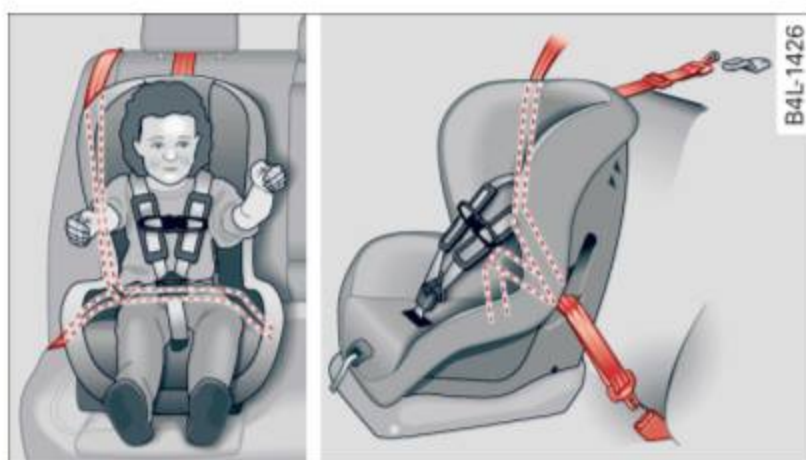

**Fig. 220** Schematic overview: installation of the seat using the vehicle's safety belt system

- ▶ When using the vehicle safety belt to install a child safety seat, you must first activate the convertible locking feature on the safety belt to prevent the child safety seat from moving ⇒ *page 215* or install the seat using the LATCH attachments.
- ▶ Push the child safety seat down with your full weight to get the safety belt really tight so that the seat cannot move forward or sideways more than one inch (2.5 cm) ⇒ *page 215*.
- ▶ If the child safety seat is equipped with a tether strap, attach it to the tether anchors ⇒ *page 222*.
- ▶ Secure unused safety belts on the rear seat ⇒ *page 210*.

A toddler or child is usually too large for an infant restraint if it is more than one year old and weighs more than 20 lbs. (9 kg).

Toddlers and children who are older than one year up to about 4 years old and weigh more than 20 lbs. (9 kg) up to 40 lbs. (18 kg) must always be properly restrained in a child safety seat certified for their size and weight ⇒ *fig. 219* and ⇒ *fig. 220*.

The airbag on the passenger side makes the front seat a potentially dangerous place for a child to ride. The front seat is not the safest place for a child in a forward-facing child safety seat. It is a very dangerous place for an infant or a larger child in a rearward-facing seat.

### WARNING

Not using a child safety seat, using the wrong child safety seat or improperly installing a child restraint increases the risk of serious personal injury and death in a collision or other emergency situation.

- Children on the front seat of any car, even with Advanced Airbags, can be seriously injured or even killed when an airbag inflates. A child in a rearward-facing child safety seat installed on the front passenger seat will be seriously injured and can be killed if the front airbag inflates – even with an Advanced Airbag System.
- The inflating airbag will hit the child safety seat or infant carrier with great force and will smash the child safety seat and child against the backrest, center armrest, door or roof.
- Always install rear-facing child safety seats on the rear seat.
- If you must install a rearward facing child safety seat on the front passenger seat because of exceptional circumstances and the **PASSENGER AIR BAG OFF** light does not come on and stay on, immediately install the rear-facing child safety seat in a rear seating position and have the airbag system inspected by your Audi dealer.
- The rear side of the child safety seat should be positioned as close as possible

to the backrest on the vehicle seat. Adjust or remove the rear seat head restraint if it is difficult to install the child seat with the head restraint in place ⇒ *page 77*. Install the head restraint again immediately once the child seat is removed. Driving without head restraints or with head restraints that are not properly adjusted increases the risk of serious or fatal neck injury dramatically.

- Always read and heed all WARNINGS whenever using a child restrained in a vehicle is being used ⇒ *page 175, Safety belts*, ⇒ *page 184, Airbag system* and ⇒ *page 205, Important things to know*.

### WARNING

If exceptional circumstances require the use of a forward-facing child restraint on the front passenger's seat, the child's safety and well-being require that the following special precautions be taken:

- Make sure the forward-facing seat has been designed and certified by its manufacturer for use on a front seat with a passenger front and side airbag.
- Always follow the manufacturer's instructions provided with the child safety seat or infant carrier.
- Always move the front passenger seat into the rearmost position of the passenger seat's fore and aft adjustment range, and as far away from the airbag as possible before installing the child restraint.
- Always make sure that nothing prevents the front passenger's seat from being moved to the rearmost position in its fore and aft adjustment range.
- Always make sure the backrest is in an upright position.
- Make sure that the **PASSENGER AIR BAG OFF** light comes on and stays on all the time whenever the ignition is switched on.
- If the light does not stay on, perform the checks ⇒ *page 195, Monitoring the Advanced Airbag System*.

- Take the child restraint off the front passenger seat and install it properly at one of the rear seat positions if the **PASSENGER AIR BAG OFF** light does not stay on whenever the ignition is switched on.

### Booster seats and safety belts

*Properly used booster seats can help protect children weighing between about 40 lbs. and 80 lbs. (18 kg and 36 kg) who are less than 4 ft. 9 in. (57 inches/1.45 meters) tall.*



**Fig. 221** Rear seat: child properly restrained in a booster seat

The vehicle's safety belts alone will not fit most children until they are at least 4 ft. 9 in. (57 inches/1.45 meters) tall and weigh about 80 lbs. (36 kg). Booster seats raise these children up so that the safety belt will pass properly over the stronger parts of their bodies and the safety belt can help protect them in a crash.

- ▶ Do not use the convertible locking retractor when using the vehicle's safety belt to restrain a child on a booster seat.
- ▶ The shoulder belt must lie as close to the center of the child's collar bone as possible and must lie flat and snug on the upper body. It must never lie across the throat or neck. The lap belt must lie across the pelvis and never across the stomach or abdomen. Make sure the belt lies flat and snug. Pull on the belt to tighten if necessary.
- ▶ If you must transport an older child in a booster seat on the front passenger seat, you can use the safety belt height adjustment to help adjust the shoulder portion properly.

- ▶ Secure unused safety belts on the rear seat  
⇒ *page 210*.

Children up to at least 8 years old (over 40 lbs. or 18 kg) are best protected in child safety seats designed for their age and weight. Experts say that the skeletal structure, particularly the pelvis, of these children is not fully developed, and they must not use the vehicle safety belts without a suitable child restraint.

It is usually best to put these children in appropriate booster seats. Be sure the booster seat meets all applicable safety standards.

Booster seats raise the seating position of the child and reposition both the lap and shoulder parts of the safety belt so that they pass across the child's body in the right places. The routing of the belt over the child's body is very important for the child's protection, whether or not a booster seat is used. Children age 12 and under must always ride in the rear seat.

Children who are at least 4 ft. 9 in. (57 inches/1.45 meters) tall can generally use the vehicle's three point lap and shoulder belts. Never use the lap belt portion of the vehicle's safety belt alone to restrain any child, regardless of how big the child is. Always remember that children do not have the pronounced pelvic structure required for the proper function of lap belt portion of the vehicle's three point lap and shoulder belts. The child's safety absolutely requires that a lap belt portion of the safety belt be fastened snugly and as low as possible around the pelvis. Never let the lap belt portion of the safety belt pass over the child's stomach or abdomen.

In a crash, airbags must inflate within a blink of an eye and with considerable force. In order to do its job, the airbag needs room to inflate so that it will be there to protect the occupant as the occupant moves forward into the airbag.

A vehicle occupant who is out of position and too close to the airbag gets in the way of an inflating airbag. When an occupant is too close, he or she will be struck violently and

will receive serious or possibly even fatal injury.

In order for the airbag to offer protection, it is important that all vehicle occupants, especially any children, who must be in the front seat because of exceptional circumstances, be properly restrained and as far away from the airbag as possible. By keeping room between the child's body and the front of the passenger compartment, the airbag can inflate completely and provide supplemental protection in certain frontal collisions.

### WARNING

Not using a booster seat, using the booster seat improperly, incorrectly installing a booster seat or using the vehicle safety belt improperly increases the risk of serious personal injury and death in a collision or other emergency situation. To help reduce the risk of serious personal injury and/or death:

- The shoulder belt must lie as close to the center of the child's collar bone as possible and must lie flat and snug on the upper body. It must never lie across the throat or neck. The lap belt must lie across the pelvis and never across the stomach or abdomen. Make sure the belt lies flat and snug. Pull on the belt to tighten if necessary.
- Failure to properly route safety belts over a child's body will cause severe injuries in an accident or other emergency situation ⇒ *page 175*.
- The rear side of the child safety seat should be positioned as close as possible to the backrest on the vehicle seat. Adjust or remove the rear seat head restraint if it is difficult to install the child seat with the head restraint in place ⇒ *page 77*. Install the head restraint again immediately once the child seat is removed. Driving without head restraints or with head restraints that are not properly adjusted increases the risk of serious or fatal neck injury dramatically.

- Children on the front seat of any car, even with Advanced Airbags, can be seriously injured or even killed when an airbag inflates.
- Never let a child stand or kneel on any seat, for example the front seat.
- Never let a child ride in the cargo area of your vehicle.
- Always remember that a child leaning forward, sitting sideways or out of position in any way during an accident can be struck by a deploying airbag. This will result in serious personal injury or death.
- If you must install a booster seat on the front passenger seat because of exceptional circumstances the **PASSENGER AIR BAG OFF** light must come on and stay on, whenever the ignition is switched on.
- If the **PASSENGER AIR BAG OFF** light does not come on and stay on, perform the checks described ⇒ *page 195, Monitoring the Advanced Airbag System*.
- Take the child restraint off the front passenger seat and install it properly at one of the rear seat positions if the **PASSENGER AIR BAG OFF** light does not stay on whenever the ignition is switched on.
- Always read and heed all WARNINGS whenever using a child restrained in a vehicle is being used ⇒ *page 175, Safety belts*, ⇒ *page 184, Airbag system* and ⇒ *page 205, Important things to know*.

## Installing a child safety seat

### Securing a child safety seat using a safety belt

*Safety belts for the rear seats and the front passenger can be locked with the convertible locking retractor to properly secure child safety seats.*

The safety belts emergency locking retractors for the rear seats safety belts and for the front passenger's seat safety belt have a convertible locking retractor for child restraints.

The safety belt must be locked so that belt webbing cannot unreel. The retractor can be activated to lock the safety belt and prevent the safety belt webbing from loosening up during normal driving. A child safety seat can only be properly installed when the safety belt is locked so that the child and child safety seat will stay in place.

Always remember: Even though your vehicle is equipped with an Advanced Airbag system, all children, especially those 12 years and younger, should always ride in the back seat properly restrained for their age and size.

### WARNING

Improperly installed child safety seats increase the risk of serious personal injury and death in a collision.

- Always make sure that the safety belt retractor is locked when installing a child safety seat. An unlocked safety belt retractor cannot hold the child safety seat in place during normal driving or in a crash.
- Always buckle the child safety seat firmly in place even if a child is not sitting in it. A loose child safety seat can fly around during a sudden stop or in a collision.
- Always make sure that the rear seat backrest to which the center rear safety belt is attached is securely latched whenever the rear center safety belt is being used to secure a child restraint.
- If the backrest is not securely latched, the child and the child restraint will be thrown forward together with the backrest and will strike parts of the vehicle interior. The child can be seriously injured or killed.
- Never install rear-facing child safety seats or infant carriers on the front passenger seat. A child will be seriously injured and can be killed when the passenger airbag inflates.
- The inflating airbag will hit the child safety seat or infant carrier with great force and will smash the child safety seat

and child against the backrest, center armrest, door or roof.

- Always install rear-facing child safety seats or infant carriers on the rear seat.
- Forward-facing child safety seats or infant carriers installed on the front passenger's seat may interfere with the deployment of the airbag and cause serious injury to the child.
- It is safer to install a forward-facing child safety seat on the rear seat.
- Always read and heed all WARNINGS whenever using a child restrained in a vehicle is being used ⇒ *page 205*. Special precautions apply when installing a child safety seat on the front passenger seat ⇒ *page 186, Child restraints on the front seat – some important things to know*.

### WARNING

Always take special precautions if you must install a forward or rearward-facing child restraint on the front passenger's seat in exceptional situations:

- Whenever a forward or rearward-facing child restraint is installed on the front passenger seat, the **PASSENGER AIR BAG OFF** light must come on and stay on whenever the ignition is switched on.
- If the **PASSENGER AIR BAG OFF** light does not come on and stay on, perform the checks described ⇒ *page 195, Monitoring the Advanced Airbag System*.
- Take the child restraint off the front passenger seat and install it properly at one of the rear seat positions if the **PASSENGER AIR BAG OFF** light does not stay on whenever the ignition is switched on.
- Improper installation of child restraints can reduce their effectiveness or even prevent them from providing any protection.
- An improperly installed child restraint can interfere with the airbag as it deploys and seriously injure or even kill the child.

- Always carefully follow the manufacturer's instructions provided with the child safety seat or carrier.
- Never place additional items on the seat that can increase the total weight registered by the weight-sensing mat and can cause injury in a crash.

### WARNING

Forward-facing child restraints:

- Always make sure the forward-facing seat has been designed and certified by its manufacturer for use on a front seat with a passenger front and side airbag.
- Never put the forward-facing child restraint up, against or very near the instrument panel.
- Always move the passenger seat into its rearmost position in the seat's fore and aft adjustment range, as far away from the airbag as possible before installing the forward-facing child restraint. The backrest must be adjusted to an upright position.
- Make sure that the **PASSENGER AIR BAG OFF** light comes on and stays on all the time whenever the ignition is switched on.

### WARNING

Rearward-facing child restraints:

- A child in a rearward-facing child safety seat installed on the front passenger seat will be seriously injured and can be killed if the front airbag inflates - even with an Advanced Airbag System.
- The inflating airbag will hit the child safety seat or infant carrier with great force and will smash the child safety seat and child against the backrest, center armrest, door or roof.
- Always be especially careful if you must install a rearward facing child safety seat on the front passenger seat in exceptional circumstances.

- A tight tether strap on a rearward-facing child restraint attached to the front passenger seat can put too much pressure on the weight-mat in the seat and register a heavier weight in the Advanced Airbag System. The heavier weight registered can make the system work as though an adult were on the seat and deploy the Advanced Airbag when it must be suppressed causing serious or even fatal injury to the child.
- Make sure that the **PASSENGER AIR BAG OFF** light comes on and stays on all the time whenever the ignition is switched on.
- If the **PASSENGER AIR BAG OFF** light does not come on and stay on, immediately install the rear-facing child safety seat in a rear seating position and have the airbag system inspected by your Audi dealer.

### Activating the convertible locking retractor

*Use the convertible locking retractor to secure a child restraint.*

Always heed the child safety seat manufacturer's instructions when installing a child restraint in your vehicle. To activate the convertible locking retractor:

- ▶ Place the child restraint on a seat, preferably on the rear seat.
- ▶ Slowly pull the belt **all the way out**.
- ▶ Route it around or through the child restraint belt path ⇒ .
- ▶ Push the child safety seat down with your full weight to get the safety belt really tight.
- ▶ Insert the belt tongue into the buckle for that seating position.
- ▶ Guide the safety belt back into the retractor until the belt lies flat and snug on the child safety seat.
- ▶ You should hear a “clicking” noise as the belt winds back into the inertia reel. Test the convertible locking retractor by pulling on the belt. You should no longer be able to

pull the belt out of the retractor. The convertible locking retractor is now activated.

- ▶ Make sure that the red release button is facing away from the child restraint so that it can be unbuckled quickly.
- ▶ Pull on the belt to make sure the safety belt is properly tight and fastened so that the seat cannot move forward or sideways more than one inch (2.5 cm).

### WARNING

Using the wrong child restraint or an improperly installed child restraint can cause serious personal injury or death in a crash.

- Always make sure that the safety belt retractor is locked when installing a child safety seat. An unlocked safety belt retractor cannot hold the child safety seat in place during normal driving or in a crash.
- Always buckle the child safety seat firmly in place even if a child is not sitting in it. A loose child safety seat can fly around during a sudden stop or in a crash.
- Always make sure the seat backrest to which the child restraint is installed is in an upright position and securely latched into place and cannot fold forward. Otherwise, the seatback with the child safety seat attached to it could fly forward in the event of an accident or other emergency situation.
- Always read and heed all WARNINGS whenever using a child restrained in a vehicle is being used ⇒ *page 205*. Special precautions apply when installing a child safety seat on the front passenger seat ⇒ *page 186, Child restraints on the front seat - some important things to know*.

### Deactivating the convertible locking retractor

The convertible locking retractor for child restraints will be deactivated automatically when the belt is wound all the way back into the retractor.

- ▶ Press the red button on the safety belt buckle. The belt tongue will pop out of the buckle.
- ▶ Guide the safety belt all the way back into its stowed position.

Always let the safety belt retract completely into its stowed position. The safety belt can now be used as an ordinary safety belt without the convertible locking retractor for child restraints.

If the convertible locking retractor should be activated inadvertently, the safety belt must be unfastened and guided completely back into its stowed position to deactivate this feature. If the convertible locking retractor is not deactivated, the safety belt will gradually become tighter and uncomfortable to wear.

#### WARNING

Improperly installed child safety seats increase the risk of serious personal injury and death in a collision.

- Never unfasten the safety belt to deactivate the convertible locking retractor for child restraints while the vehicle is moving. You would not be restrained and could be seriously injured in an accident.
- Always read and heed all WARNINGS whenever using a child restrained in a vehicle is being used ⇒ *page 205*. Special precautions apply when installing a child safety seat on the front passenger seat ⇒ *page 186, Child restraints on the front seat – some important things to know*.

## LATCH Lower anchorages and tethers for children

### Child Restraint System anchors and how are they related to child safety

To provide a simpler and more practicable way to attach the child restraint on the vehicle seat, Federal regulations require special lower anchorages in vehicles and devices on new child restraints to attach to the vehicle anchorages.

The combination of the tether anchorages and the lower anchorages is now generally called the **LATCH** system for “**L**ower **A**nchorages and **T**ethers for **C**hildren.”

Forward-facing child restraints manufactured after September 1, 1999, are required by U.S. federal regulations to comply with new child head movement performance requirements. These new performance requirements make a tether necessary on most new child seats.

Installing a child restraint that requires a top tether without one can seriously impair the performance of the child restraint and its ability to protect the child in a collision. Installing a child restraint that requires a top tether without the top tether may be a violation of state law.

Child restraint manufacturers offer LATCH lower anchorages on their child seats with hook-on or push-on connectors attached to adjustable straps.

In addition to the LATCH lower anchorages, these child restraint systems usually require the use of tether straps to help keep the child restraint firmly in place.

#### WARNING

Improper installation of child restraints will increase the risk of injury and death in a crash.

- Always follow the instructions provided by the manufacturer of the child restraint you intend to install in your vehicle.
- Never install a child restraint without a properly attached top tether strap if the child restraint manufacturer's instructions require the top tether strap to be used.
- Improper use of child restraint LATCH lower anchorage points can lead to injury in a collision. The LATCH lower anchorage points are designed to withstand only those loads imposed by correctly fitted child restraints.
- Never mount two child restraint systems on one LATCH lower anchorage point.
- Never secure or attach any luggage or other item to the LATCH lower anchorages.

**i Tips**

- In Canada, the terms “top tether” with “lower universal anchorages” (or “lower universal anchorage bars”) are used to describe the system.
- In other countries, the term “ISOFIX” is used to describe the lower anchorages.

**Location**

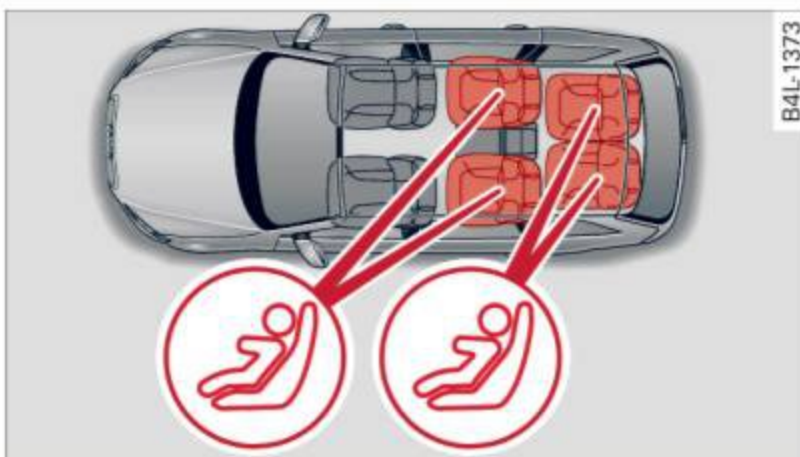

**Fig. 222** Schematic overview: LATCH anchorage point locations

The illustration shows the seating locations in your vehicle which are equipped with the lower anchorages system.

**Description**

The lower anchorage positions are marked for quick locating.



**Fig. 223** Second row of seats: lower anchorage bracket locations

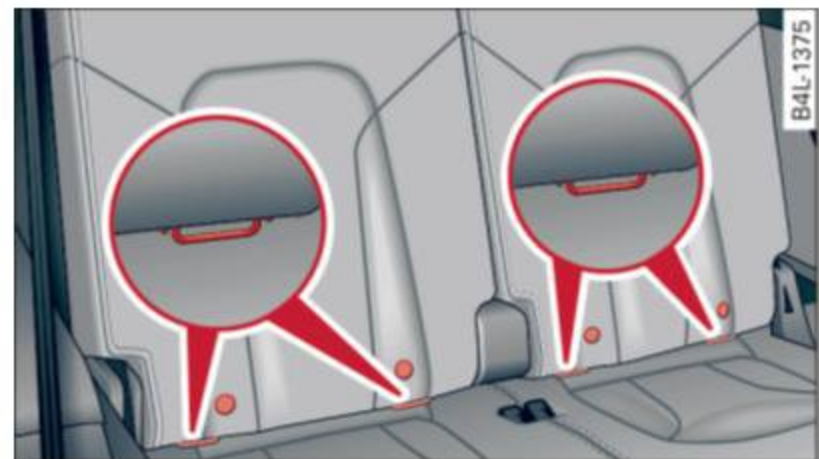

**Fig. 224** Third row of seats: locator buttons for lower anchorages

**Attachment locator markers for lower anchorages**

The lower anchorage locations in the second row of seats are indicated by the attachment locator markers of the lower anchorage brackets ⇒ *fig. 223*. Remove the covers to access the lower anchorage brackets. Circular locator buttons on the third row of seats\* indicate the lower anchorage locations on the third row of seats ⇒ *fig. 224*.

**Lower anchorages**

The lower anchorage attachment points are located between the rear seatback and rear seat cushion ⇒ *fig. 223* or ⇒ *fig. 224*.

Lower anchorages secure the child restraint in the seat without using the vehicle's safety belts. Anchorages provide a secure and easy-to-use attachment and minimize the possibility of improper child restraint installation. ▶

All child restraints manufactured after September 1, 2002, must have lower anchorage attachments for the *LATCH* system.

Remember that the lower anchorage points are only intended for installation and attachment of child restraints specifically certified for use with *LATCH* lower anchorages. Child restraints that are not equipped with the lower anchorage attachments can still be installed in compliance with the child restraint manufacturer's instructions on using vehicle safety belts.

### **WARNING**

Improper use of *LATCH* lower anchorages can cause serious personal injury in an accident.

- Always carefully follow the child restraints manufacturer's instructions for proper installation of the child restraint and proper use of the lower anchorages or safety belts in your vehicle.
- Never secure or attach any luggage or other items to the *LATCH* lower anchorages.
- Always read and heed the important information about child restraints in this chapter and **WARNINGS** ⇒ page 205, *Child Safety*.

### **Guidance fixtures for lower anchorages**

Applies to vehicles: with third row seating

*Special guidance fixtures increase the convenience of the lower anchorages and are available from your authorized Audi dealer.*

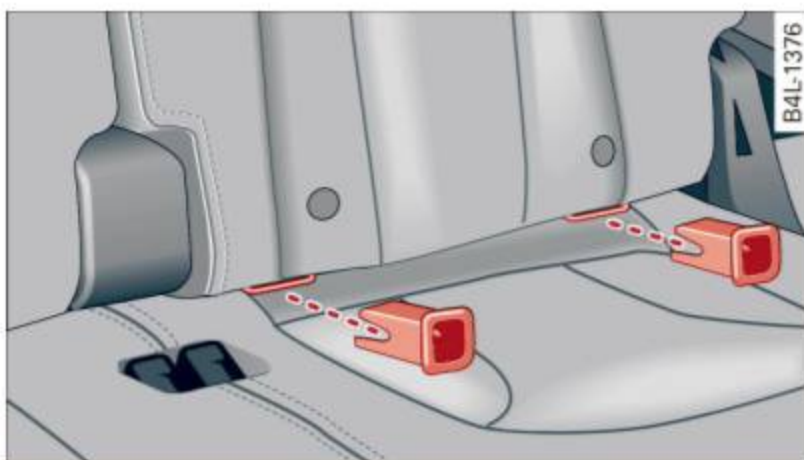

**Fig. 225** Third row of seats: installing the guidance fixtures

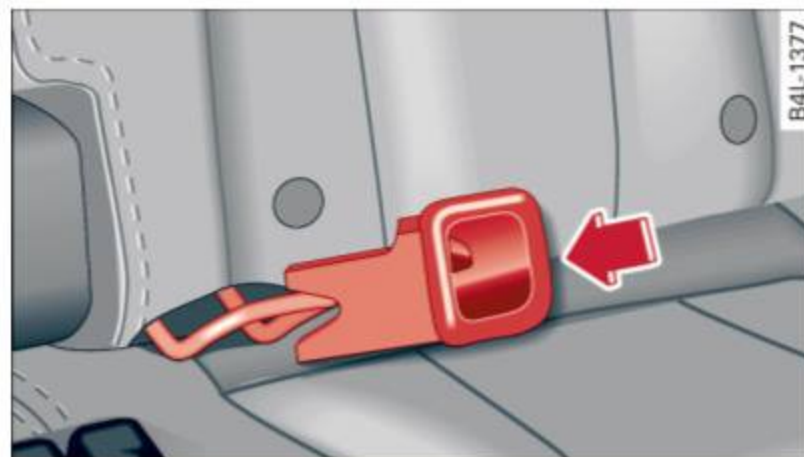

**Fig. 226** Close-up: fitting the guidance fixture over the lower anchorage bracket

The lower anchorage attachment points are located on the third row of seats between the seatback and the seat cushion. Special guidance fixtures increase the convenience of the lower anchorages and help protect the seat material from possible damage when installing child restraints.

### **Installing the guidance fixtures**

- ▶ Push down on the seat cushion so that the lower anchorages are visible.
- ▶ Hold the guidance fixture with the part number facing downward and push it in the direction of the arrow onto the anchorage ⇒ *fig. 226*.
- ▶ Make sure that each of the two guidance fixtures per seat snaps into place.

### **Removing the guidance fixtures**

- ▶ Remove the child restraint according to the child restraint manufacturer's instructions.
- ▶ Push down on the seat cushion so that the lower anchorages are visible.
- ▶ Pull off the guidance fixtures from the lower anchorages.
- ▶ Always remove the guidance fixtures and keep them in a safe place when not in use.

You may find it easier to install child restraints equipped with hooks attached to straps without the guidance fixtures in place. If this is the case, remove the guidance fixtures by pulling them off the anchorages. However, the guidance fixtures can help you to locate the *LATCH* anchorages.

**! WARNING**

Improper use of tether anchorages or lower anchorages can cause serious personal injury in a crash.

- Always carefully follow the child restraint manufacturer's instructions for proper installation and use of child restraint systems.
- Never use the *LATCH* or tether anchorages to attach safety belts or other kinds of occupant restraints.
- Child restraint tether attachments and lower attachments are only designed to secure a child restraint that has been equipped to use these anchorages.
- Tether anchorages and lower anchorages are designed to withstand only those loads imposed by correctly fitted child restraints. Under no circumstances can they be used safely for adult or child safety belts or harnesses.
- Never mount more than one child restraint to a single tether or to a lower anchorage point. Attaching two child restraints to a single anchorage point can cause the anchorage to fail and cause serious personal injury in a crash.

**! Note**

- Remove the guidance fixtures before folding the rear seatback to prevent damaging the seat cushion.
- If you leave the guidance fixtures installed for several days, they could leave a mark on the upholstery on the seat cushion and backrest in the area that the guidance fixtures were installed. The upholstery would also be permanently stretched around the guidance fixtures. This applies especially to leather seats.

**Installing a child restraint with LATCH lower anchorages**

*Whenever you install a child restraint always follow the child restraint manufacturer's instructions.*

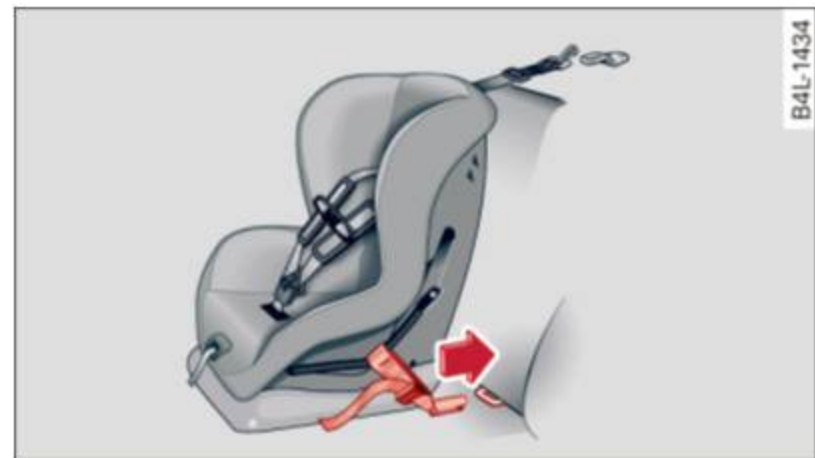

Fig. 227 Lower anchorages: proper mounting

**Mounting**

- ▶ Make sure the seatback of the rear seat bench is in the upright position and securely latched in place.
- ▶ Attach both hook-on connectors with the spring catch release on the child safety seat onto the LATCH lower anchorage so that the connectors lock into place ⇒ *fig. 227*.
- ▶ Pull on the connector attachments to make sure they are properly attached to the LATCH lower anchorage.
- ▶ Pull straps tight following the child restraint manufacturer's instructions.

**Releasing**

- ▶ Loosen the tension on the straps following the child restraint manufacturer's instructions.
- ▶ Depress the spring catches to release the anchorage hooks from the lower anchorages.

Remember: Use tether straps to help keep the child restraint firmly in place.

**! WARNING**

Improper use of the LATCH system can increase the risk of serious personal injury and death in an accident.

- These anchors were developed only for child safety seats using the “LATCH” system.
- Never attach other child safety seats, belts or other objects to these anchors.
- Always make sure that you hear a click when latching the seat in place. If you do not hear a click the seat is not secure and could fly forward and hit the interior of the vehicle, or be ejected from the vehicle.

### WARNING

Improper installation of child restraints will increase the risk of injury in an accident.

- Always follow the child restraint system manufacturer's instructions for proper installation of the child restraint system and proper use of tether straps as well as the lower anchorages or safety belts in your vehicle.
- Always read and heed the important information and WARNINGS about child safety and the installation of child restraint systems ⇒ *page 205, Child Safety*.

### Tether anchors and tether straps

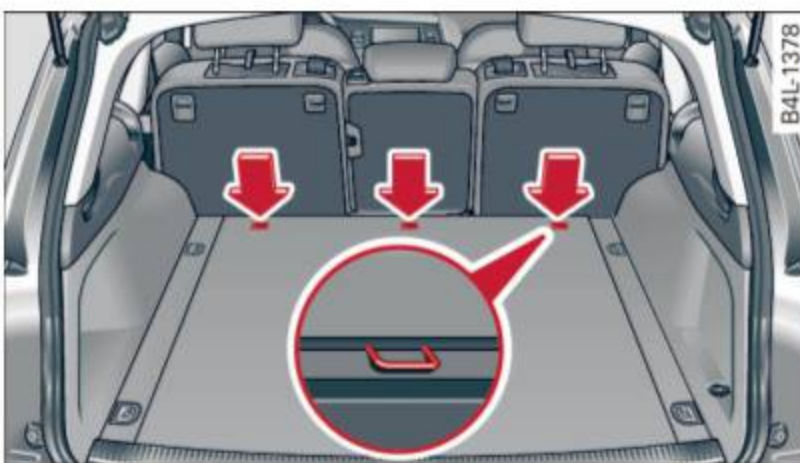

**Fig. 228** Tether anchors for second row of seats: attachment hook locations



**Fig. 229** Tether anchors for third row of seats: attachment hook locations

The tether anchors for the three rear seating positions in the second row of seats are located underneath the seats in the back

⇒ *fig. 228*. For vehicles with third row seating\*, the tether anchors for the two seating positions in the third row of seats are stored underneath a plastic cover cap in the floor ⇒ *fig. 229*.

A tether is a straight or V-shaped strap that attaches the top part of a child restraint to special anchorage points in the vehicle.

The purpose of the tether is to reduce the forward movement of the child restraint in a crash, in order to help reduce the risk of head injury that could be caused by striking the vehicle interior.

Forward facing child restraints manufactured after September 1, 1999, are required by U.S. federal regulations to comply with new child head movement performance requirements. These new performance requirements make a tether necessary on most new child safety seats.

### WARNING

Improper installation of child restraints will increase the risk of injury and death in a crash.

- Always follow the instructions provided by the manufacturer of the child restraint you intend to install in your Audi.

- Improper use of child restraint anchors (including tether anchors) can lead to injury in a collision. The anchors are designed to withstand only those loads imposed by correctly fitted child restraints.
- Never mount two child restraint systems on one LATCH lower anchor point.
- Never attach two child restraint systems to one tether strap or tether anchorage.
- Never attach a tether strap to a tie-down hook in the luggage compartment.
- Never use child restraint tether anchorages to secure safety belts or other kinds of occupant restraints.
- Never secure or attach any luggage or other items to the LATCH lower anchorages or to the tether anchors.
- If a tether or other strap is used to attach a child restraint to the front passenger seat, make sure that it is not so tight, that it causes the weight-sensing mat to measure more weight than is actually on the seat.
- The heavier weight registered can make the Advanced Airbag System work as though an adult were on the seat and deploy the Advanced Airbag when it must be suppressed causing serious or even fatal injury to the child.
- If you must install a rearward facing child safety seat on the front passenger seat because of exceptional circumstances and the **PASSENGER AIR BAG OFF** light does not come on and stay on, immediately install the rear-facing child safety seat in a rear seating position and have the airbag system inspected by your Audi dealer.

### Installing the upper tether strap on the anchorage

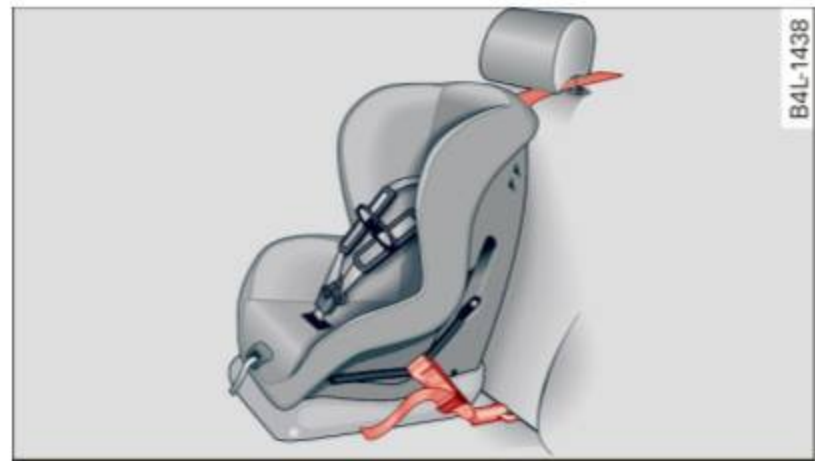

Fig. 230 Tether strap: proper routing and mounting

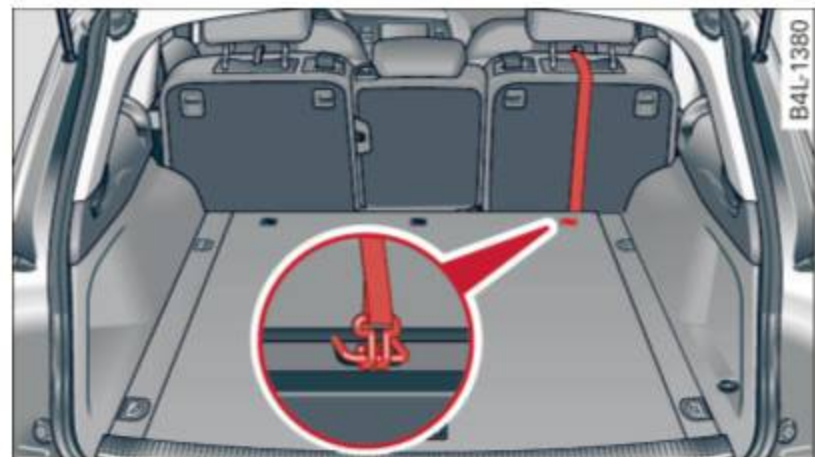

Fig. 231 Tether strap for second row seats: proper routing and mounting

### Installing the tether strap

- ▶ Release or deploy the tether strap on the child restraint according to the child restraint manufacturer's instructions.
- ▶ Guide the upper tether strap **under** the rear head restraint and into the rear cargo area (raise the head restraint if necessary).
- ▶ **For the second row of seats:** Pull the flooring back, in order to reach the anchor bracket ⇒ *fig. 231*.
- ▶ **For the third row of seats:**\* Remove the plastic cover cap with a screw driver, in order to reach the anchor bracket ⇒ *page 222, fig. 229*.
- ▶ Slide the tether strap hook over the anchor bracket.
- ▶ Pull on the tether strap hook so that the spring catch of the hook engages.
- ▶ Tighten the tether strap firmly following the child restraint manufacturer's instructions.
- ▶ **For the second row of seats:** Push the flooring forward into place again. ▶

### Releasing the tether strap

- ▶ Loosen the tension following the child restraint manufacturer's instructions.
- ▶ Depress the spring catch on the hook and release it from the anchorage.
- ▶ **For the second row of seats:** Push the flooring forward into place again.
- ▶ **For the third row of seats:**\* Replace the plastic cover cap.

#### Note

If you leave the child restraint with the tether strap firmly installed for several days, this could leave a mark on the upholstery on the seat cushion and backrest in the area where the tether strap was installed. The upholstery would also be permanently stretched around the tether strap. This applies especially to leather seats.

### Using tether straps on rearward-facing child restraints

Currently, few rear-facing child restraint systems come with a tether. Please read and heed the child restraint system manufacturer's instructions carefully to determine how to properly install the tether.

#### WARNING

A child in a rearward-facing child safety seat installed on the front passenger seat will be seriously injured and can be killed if the front airbag inflates - even with an Advanced Airbag System.

- The inflating airbag will hit the child safety seat or infant carrier with great force and will smash the child safety seat and child against the backrest, center armrest, or door.
- A tight tether or other strap on a rearward-facing child restraint attached to the front passenger seat can put too much pressure on the weight-mat in the seat and register a heavier weight in the Advanced Airbag System. The heavier

weight registered can make the system work as though an adult were on the seat and deploy the Advanced Airbag when it must be suppressed causing serious or even fatal injury to the child.

- If you must install a rearward facing child safety seat on the front passenger seat because of exceptional circumstances and the **PASSENGER AIR BAG OFF** light does not come on and stay on, immediately install the rear-facing child safety seat in a rear seating position and have the airbag system inspected by your Audi dealer.

## Additional Information

### Sources of information about child restraints and their use

There are a number of sources of additional information about child restraint selection, installation and use:

NHTSA advises that the best child safety seat is the one that fits your child and fits in your vehicle, and that you will use correctly and consistently.

Try before you buy!

#### **U.S National Highway Traffic Safety Administration**

Tel.: 1-888-327-4236 (TTY: 1-800-424-9153)  
<http://www.nhtsa.gov>

#### **National SAFE KIDS Campaign**

Tel.: (202) 662-0600  
<http://www.safekids.org>

#### **Safety BeltSafe U.S.A**

Tel.: (800) 745-SAFE (English)  
 Tel.: (800) 747-SANO (Spanish)  
<http://www.carseat.org>

#### **Transport Canada Information Centre**

Tel.: 1-800-333-0371 or call  
 1-613-998-8616 if you are in the Ottawa area  
<http://www.tc.gc.ca/eng/roadsafety/menu.htm>

#### **Audi Customer Relations**

Tel.: (800) 822-2834

## Intelligent technology

### Notice about data recorded by vehicle control modules

Your vehicle is not equipped with an Event Data Recorder (EDR), installed by some manufacturers for the express purpose of capturing data for retrieval after an accident or crash event. EDRs are sometimes called “crash recorders”.

Some state laws restrict the retrieval or downloading of data stored by EDRs that were installed in a vehicle for the express purpose of retrieving data after an accident or crash event without the owner’s consent.

Although your vehicle is not equipped with an EDR, it is equipped with a number of electronic control modules for various vehicle systems such as, for example, engine function, emission control, as well as for the airbags and safety belts.

These electronic control modules also record vehicle-related data during normal vehicle operation for diagnostic and repair purposes. The recording capacity of the electronic control modules is limited to data (no sound is recorded) and only a small amount of data is actually recorded over a very limited period of time and stored when a system fault or other condition is sensed by a control unit. Some of the data then stored may relate to vehicle speed, direction, braking as well as restraint system use and performance in the event of a crash or other condition. Stored data can only be read and downloaded with special equipment.

## Electronic Stabilization Control (ESC)

### General information

*The ESC improves the vehicle stability.*

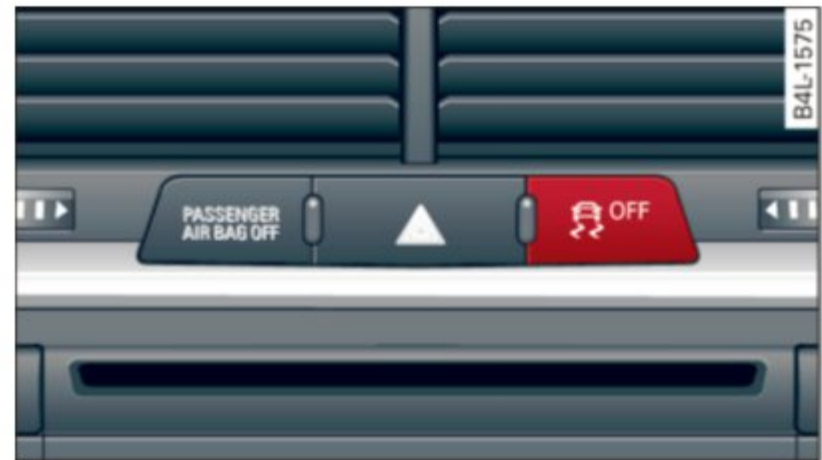

Fig. 232 Center console with ESC switch

ESC is designed to help you maintain vehicle control in situations where the car approaches the limits of “grip”, especially when accelerating and cornering. ESC reduces the risk of skidding and improves stability under all road conditions.

The system operates across the entire speed range in combination with the ABS system. If the Anti-Lock Brake System (ABS) malfunctions, the ESC will also shut down.

### How the system works

The Anti-Lock Brake System (ABS), Electronic Differential Lock (EDL) and the Anti-Slip Regulation System (ASR) are integrated in the Electronic Stabilization Control. In addition to the data provided by these functions, the ESC control unit requires additional measurement data provided by high performance sensors. The rotational speed of the vehicle about its vertical axis, vehicle acceleration in the fore-and-aft and lateral directions, the brake pressure and the steering angle are all measured.

The direction in which the driver wishes to travel is determined with the aid of the steering angle and vehicle speed and is continually compared with the actual behavior of the vehicle. If the two do not match, for example, when the vehicle starts hydroplaning on a wet road, ESC will automatically brake the appropriate wheel to correct the problem. ▶

The vehicle is then stabilized by the forces acting on the wheel during braking. If the vehicle is *oversteering* (rear tends to skid out of the turn), the brakes are mainly applied on the wheel that is on the outside of the curve. In the case of a vehicle that is *understeering* (tendency to slide out of the curve), the brakes are applied as needed on the wheel that is on the inside of the curve or additionally on the other wheels. An acoustic signal indicates when ESC brake application cuts in ⇒ .

The system operates across the entire speed range in combination with the ABS system ⇒ *page 229*. If the Anti-Lock Brake System (ABS) malfunctions, the ESC will be out of action as well.

### Activating

When you turn on the engine, ESC will automatically be activated and will perform a self-test. As soon as the test is completed, the system is in normal operating mode.

### Offroad mode

ESC should normally be operated in normal mode because this ensures maximum vehicle stability. If necessary, you can activate the ESC offroad mode by pressing the button ⇒ *fig. 232* to obtain maximum traction and braking ability when driving off paved roads at low speeds. In ESC offroad mode, the indicator light  illuminates and the message **Stabilization control (ESC): Offroad. Warning! Restricted stability** appears briefly in the display.

The ESC offroad mode can be useful in the following exceptional situations when slip or a highly effective differential locking function is desirable. Examples:

- when driving with tire chains,
- when driving in deep snow or on loose ground,
- when driving on uneven surfaces with the wheels severely unloaded (articulation), and
- when rocking the vehicle loose after it has become stuck.

When the unusual situation is past, you should shift back to the normal ESC operating mode by pushing the button again. The message **Stabilization control (ESC): On** then appears briefly in the display.

### Hill descent control

The hill descent control is switched on in ESC offroad mode. When slowly descending steep gradients on loose ground or when the axles are articulated, hill descent control provides assistance by automatically applying the brakes to keep vehicle speed constant. The vehicle is also rendered easier to steer by selective distribution of braking force. Hill descent control intervenes when:

- the accelerator pedal is not pressed,
- the vehicle is travelling less than 12 mph (20 km/h),
- a steep gradient is detected,
- wheel behavior indicates loose ground or conditions with poor adhesion (e.g. also axle articulation).

Hill descent control operates both driving forward and in reverse. Active hill descent control is deactivated by pressing the accelerator pedal until the conditions for activation already listed are met again.

### **WARNING**

- The Electronic Stabilization Control is nevertheless subject to the laws of physics. It is particularly important to pay attention to this fact on wet and slippery roads. It is therefore important that you always adapt your driving to the condition of the road and traffic conditions. Do not allow the increased safety provided by the Electronic Stabilization Control system to lull you into accepting additional safety risks.
- Please be aware that in ESC offroad mode, particularly on a smooth and slippery road, the wheels may have an increased tendency to spin and the vehicle may break away - danger of skidding!

- Stability is limited in the ESC offroad mode.

### Electronic differential lock (EDL)

The electronic differential lock monitors the rotational speed of the drive wheels.

#### General notes

The electronic differential lock (EDL) helps the car to start moving, accelerate and climb a gradient on surfaces providing poor or almost no grip. Without EDL, this would be difficult, if not impossible.

#### How the system works

The EDL operates automatically. It monitors the rotational speed of wheels with the help of the ABS sensors ⇒ page 229. If a noticeable *slip* is detected at the wheels (e.g. on slippery ground *on one side*), the spinning wheels are braked and power is transferred to the other wheels. This is done up to a speed of about 60 mph (100 km/h). Noises from the brake system signal that wheel spin is being controlled.

#### Driving off

When driving off, always be sure to keep road conditions in mind as you accelerate. If one drive wheel spins because it is on a surface with less grip, apply *plenty of* throttle until the car starts to move.

#### Overheating of brakes

To prevent the disc brake of the braked wheel from overheating if subjected to excessive loads on this wheel, the EDL cuts out temporarily. The vehicle remains operational and behaves in the same way as a vehicle without EDL.

As soon as the brake has cooled down, EDL switches on again automatically.

#### WARNING

- When accelerating on slippery surfaces, such as on ice or snow, always be careful when depressing the accelerator pedal.

- Even with the EDL working, the drive wheels can spin and reduce your ability to control your car. Risk of crash!
- The increased safety afforded by EDL does not mean that you can take safety risks. Always adapt your driving style to the road conditions and traffic situation.

#### Tips

If a fault occurs in the ABS, the EDL is also not functioning. This is indicated by the ABS warning light ⇒ page 18.

### Anti-Slip Regulation System (ASR)

The Anti-Slip Regulation System prevents the driven wheels from spinning when the car is accelerating.

#### General notes

The Anti-Slip Regulation System (ASR) is integrated in the Electronic Stabilization Control (ESC). When the vehicle starts up and accelerates, the wheels are prevented from spinning by adjusting the engine power to match the amount of grip available from the road surface.

#### How the system works

ASR performs automatically, i.e. without the driver's intervention. With the aid of the ABS sensors ⇒ page 229, ASR monitors the speed of the driven wheels. If the wheels start to spin, engine torque is reduced automatically until the tires find enough grip to lock onto the road surface. The system is active across the entire speed range.

The ASR works in conjunction with the ABS. If a malfunction should occur in the ABS, the ASR will also be out of action.

#### WARNING

The increased safety afforded by ASR does not mean that you can take safety risks. Always adapt your driving style to the road conditions and traffic situation.

**i Tips**

To ensure that the ASR works properly, all four wheels must be fitted with identical tires. Any differences in rolling radius of the tires can cause the system to reduce engine power when this is not desired. See also ⇒ *page 291, New tires and replacing tires and wheels.*

## Braking

### General information

*What affects braking efficiency?*

#### Operating conditions and driving habits

The brakes on today's automobiles are still subject to wear, depending largely on operating conditions and driving habits ⇒ ⚠. On vehicles that are either driven mostly in stop-and-go city traffic or are driven hard, the brake pads should be checked by your authorized Audi dealer more often than specified in the **Warranty & Maintenance booklet**. Failure to have your brake pads inspected can result in reduced brake performance.

On steep slopes, you should use the braking effect of the engine. This way, you prevent unnecessary wear on the brake system. If you must use your brakes, do not hold the brakes down continuously. Pump the brakes at intervals.

Noises may occur when braking depending on the speed, braking force and outside conditions such as temperature and humidity.

#### Moisture or road salt

Under certain conditions, for example, when driving through water or very heavy rain, or even after washing your vehicle, the braking effect can be reduced due to moisture (or in freezing conditions ice) on the brake pads. A few careful brake applications should dry off the brake pads or remove any ice coatings.

When you are driving at higher speeds with the windshield wipers on, the brake pads will briefly touch the brake discs in regular inter-

vals so as to improve reaction time when braking on wet surfaces. You, the driver, will not notice anything.

The effectiveness of the brakes can be reduced when the vehicle is driven on a salt-covered road and the brakes are not used. Here too, you should clean off accumulated salt coating from brake discs and pads with a few careful applications of the brake ⇒ ⚠.

#### Corrosion

There may be a tendency for dirt to build up on the brake pads and corrosion to form on the discs if the car is not driven regularly or only for short trips with little use of the brakes.

If the brakes are not used frequently, or if corrosion has formed on the discs, it is advisable to clean off the pads and discs by braking firmly a few times from a moderately high speed ⇒ ⚠.

#### Faults in the brake system

If you should notice a *sudden* increase in brake pedal travel, then one of the two brake circuits may have failed ⇒ ⚠.

#### Low brake fluid level

Malfunctions can occur in the brake system if the brake fluid level is too low. The brake fluid level is monitored electronically.

#### Brake lining wear status

Brake lining wear may be checked by visual inspection of the condition of the brake pads through the openings in the wheel. If necessary, the wheel may be removed for this inspection ⇒ *page 304, Changing a wheel.*

**⚠ WARNING**

- You should perform braking maneuvers for the purpose of cleaning the brake system only if road conditions permit. Other road users must not be put at risk - you may cause an accident!

- Before descending a steep grade, reduce speed and shift transmission into a lower gear or lower driving range. Do not ride the brakes or hold the pedal down too long or too often. This could cause the brakes to get hot and diminish braking efficiency.
- Do not “ride the brakes” by resting your foot on the pedal when you do not intend to brake. This may cause the brakes to overheat, premature wear and increased stopping distance.
- Under certain climatic and operating conditions such as passing through water, driving in heavy rain or after washing the vehicle, the effectiveness of the brakes can be reduced. In winter, ice can accumulate on the brake pads, linings, discs and drums. Carefully apply brakes for a test. Brakes will dry and ice coatings will be cleaned off after a few careful brake applications.
- Driving for an extended period of time on salt-covered roads without using your brakes can also affect braking efficiency. Clean off accumulated salt coating from brake discs and pads with a few careful brake applications.
- If you damage the front spoiler, or if you install a different spoiler, be sure the air flow to the front brakes is not obstructed. Otherwise the brake system could overheat reducing the effectiveness of the entire brake system.
- Failure of one brake circuit will impair the braking capability resulting in an increased stopping distance. Avoid driving the vehicle and have it towed to the nearest authorized Audi dealer or qualified workshop.

### Brake booster

*The brake booster adds extra braking power.*

The brake booster works with vacuum pressure which is created only when the engine is running ⇒ ⚠.

### ⚠ WARNING

- Never let the vehicle roll to a stop with the engine shut off.
- If the brake booster is not working, for example when towing your vehicle, or because the brake booster has somehow been damaged, the brake pedal must be pressed considerably harder to make up for the lack of booster assistance.

### Functioning of Anti-Lock Brake System (ABS)

*ABS prevents the wheels from locking up under braking.*

The ABS contributes effectively to vehicle control since it prevents the wheels from *locking* when the brakes are applied. This means that the vehicle remains steerable and is less likely to skid.

**With ABS you do not need to pump the brake. Just hold the brake pedal down.**

However, do not expect the ABS to shorten braking distance under *all* circumstances. When driving on gravel or on newly fallen snow on top of icy surfaces, braking distance may be even longer, therefore, under these circumstances, it is especially important that you drive slowly and with great care.

### How the ABS system works

An automatic check is made when a speed of about 12 mph (20 km/h) is reached. When this happens, a pumping noise can be heard.

If an individual wheel begins to rotate too slowly in relation to vehicle speed and tends to lock, the ABS automatically reduces brake pressure to prevent that wheel from locking.

This automatic adjustment process will cause a **slight vibration** of the brake pedal and some noises to alert you that vehicle speed must be adapted to existing road and traffic conditions. ▶

**! WARNING**

Although the ABS is very effective, always remember that braking capability is limited by tire traction. Always adjust your driving speed according to the road and traffic conditions. Do not let the extra safety afforded by the ABS tempt you into taking extra risks. The ABS cannot overcome the laws of physics.

**i Tips**

- If ABS is not functioning properly, a warning light will come on. See ⇒ *page 18*.
- If a fault occurs in the ABS, the EDL is also not functioning. This is indicated by the ABS warning light.

**Brake assistant**

*The brake assistant is designed to achieve the optimum braking effect.*

The brake assistant helps to increase the *effective* braking power and thus to achieve a shorter stopping distance. If the driver presses the brake pedal very quickly, the brake assistant automatically boosts the braking force to the maximum level, up to the point where the anti-lock brake function (ABS) intervenes to stop the wheels from locking. You should then keep the brake pedal pressed until the vehicle has braked to the required speed. The brake assistant switches itself off as soon as you release the brake pedal.

**Automatic full braking assist**

This function allows full braking in spite of high brake pedal forces (e.g. when the brakes are severely stressed because the vehicle is fully loaded). The driver notices this function through a reduction of pedal force and increased pedal travel. When the brake pedal is released, full braking assist switches off again automatically.

If there is an ABS failure, the brake assistant and automatic full braking assist are not available.

The brake assistant will not be operative if there is a malfunction in the ABS.

**! WARNING**

Please remember that the accident risk always increases if you drive too fast, especially in corners or on a slippery road, or if you follow the vehicle ahead of you too closely. Increased risk of an accident cannot be compensated for even by the brake assistant, so always maintain a safe speed.

**Servotronic® - advanced power steering system**

*The power steering systems uses the power of the running engine to allow precise steering with little effort.*

The advanced *Servotronic®* power steering system senses the road speed and electronically adjusts power assistance to provide comfortable and safe steering response exactly matched to the vehicle speed.

Power steering will not work if the engine is off. As a result, the steering wheel will be hard to turn.

The power steering fluid level is checked during the scheduled maintenance services.

**! Note**

If there is an electronic malfunction, *servotronic* will still function like a conventional power steering system, providing a constant steering support force that is no longer proportionate to the vehicle speed. This is most noticeable when turning the steering wheel at low speeds (for example when parking), - more effort will be required than usual.

- Be aware of the different than usual steering response and adjust your steering force accordingly.
- Have the problem checked and set right by an Audi dealer as soon as possible.

**i Tips**

- When the engine is running, never hold the steering wheel turned all the way to the right or to the left for longer than 15 seconds. The power steering pump will overheat the hydraulic fluid if you keep holding the steering wheel turned all the way. This is likely to damage the power steering system.
- If the power steering system should fail entirely, or if the engine is not running (for example, while being towed), you will still be able to steer the vehicle. However, *considerably* more effort will be required to do so.
- If the power steering system should have a leak, or is not functioning properly, contact your authorized Audi dealer immediately.
- The power steering system requires a specially formulated hydraulic fluid. The power steering reservoir is the one located farthest to the rear on the left side of the engine compartment ⇒ *page 266*. The correct fluid level in the reservoir is important for proper functioning of the power steering.

## Driving with your quattro®

*With all-wheel drive, all four wheels are driven.*

### General information

With all-wheel drive, power is distributed to all four wheels. This happens automatically depending on your driving style and the road conditions at the time. See also ⇒ *page 227, Electronic differential lock (EDL)*.

### Winter tires

When driving in the winter, your vehicle with all-wheel drive has an advantage, even with regular tires. In winter road conditions it may be advisable to mount winter tires (or all-season tires) for improved driveability and brak-

ing: these tires must be mounted on **all four wheels**. See also ⇒ *page 295, Winter tires*.

### Tire chains

Where tire chains are mandatory on certain roads, this normally also applies to vehicles with all-wheel drive ⇒ *page 296, Snow chains*.

### Replacing wheels/tires

Vehicles with all-wheel drive must always have tires of the same size. Also avoid tires with different tread depths. For details see *page 291, New tires and replacing tires and wheels*.

**! WARNING**

Always adjust your driving to road and traffic conditions. Do not let the extra safety afforded by all-wheel drive tempt you into taking extra risks.

- Although the all-wheel drive is very effective, always remember that braking capacity is limited by tire traction. You should therefore not drive at excessive speeds on icy or slippery road surfaces.
- On wet road surfaces, be careful not to drive too fast because the front wheels could begin to slide on top of the water (aquaplaning). If this should occur, you will have no warning from a sudden increase in engine speed as with a front-wheel drive vehicle. Always drive at speeds which are suited to the road conditions – risk of crash.

## Energy management

**Starting ability is optimized**

*Energy management controls the distribution of electrical energy and thus optimizes the availability of electrical energy for starting the engine.*

If a vehicle with a conventional energy system is not driven for a long period of time, the battery is discharged by idling current consumers (e.g. immobilizer). In certain circumstances it ►

can result in there being insufficient energy available to start the engine.

Intelligent energy management in your vehicle handles the distribution of electrical energy. Starting ability is markedly improved and the life of the battery is extended.

Basically, energy management consists of **battery diagnosis**, **idling current management** and **dynamic energy management**.

### **Battery diagnosis**

Battery diagnosis continuously determines the state of the battery. Sensors determine battery voltage, battery current and battery temperature. This determines the current state of charge and the power of the battery.

### **Idling current management**

Idling current management reduces energy consumption while the vehicle is standing. With the ignition switched off, it controls the energy supply to the various electrical components. Data from battery diagnosis is considered.

Depending on the battery's state of charge, individual consumers are gradually turned off to prevent excessive discharge of the battery and thus maintain starting capability.

### **Dynamic energy management**

While the vehicle is being driven, dynamic energy management distributes the energy generated according to the needs of the individual components. It regulates consumption, so that more electrical energy is not being used than is being generated and ensures an optimal state of charge for the battery.

#### **Tips**

- But even energy management cannot negate the limits of physics. Consider that the power and life of a battery are limited.
- If starting ability is threatened, you are informed by a warning ⇒ *page 233, Driver notification in the instrument cluster display.*

#### **What you should know**

*The highest priority is given to maintaining starting capability.*

The battery is severely taxed in short-distance driving, in city traffic and during the cold time of year. Abundant electrical energy is required, but only a little is generated. It is also critical if the engine is not running and electrical components are turned on. In this instance energy is being consumed but none is being generated.

It is in precisely these situations that you will notice energy management actively regulating the distribution of energy.

### **Vehicle stands for an extended period**

If you do not drive your vehicle over a period of several days or weeks, electrical components are gradually cut back or switched off. This reduces energy consumption and maintains starting capability over a longer period.

Take into consideration that when you unlock your vehicle, some convenience functions, such as the interior lights or the power seat adjustment, may not be available. The convenience functions will be available again when you turn on the ignition and start the engine.

### **With the engine turned off**

If you listen to the radio, for example, with the engine turned off or use other MMI functions, the battery is being discharged.

If starting capability is jeopardized due to energy consumption, the following warning appears in the MMI display:

**Please start engine, otherwise system will switch off in 3 minutes.**

The warning indicates that the system will be turned off automatically after 3 minutes. If you wish to continue using the functions, you have to start the engine. ►

### With the engine running

Although electrical energy is generated when the vehicle is being driven, the battery can become discharged. This happens mostly when little energy is being generated and a great deal consumed and the battery's state of charge is not optimal.

To bring the energy balance back into equilibrium, consumers which require especially large amounts of energy are temporarily cut back or switched off. Heating systems in particular require a great deal of energy. If you notice, for example, that the heated seats\* or the heated rear window are not heating, they have been temporarily cut back or switched off. These systems will be available again as soon as the energy balance has been restored.

You will also notice that engine idle speed has been increased slightly. This is normal and not a cause for concern. By increasing engine idle speed the additional energy required is generated and the battery is charged.

### Driver notification in the instrument cluster display

If battery power drops into the range where it can limit the ability of the engine to start, this is shown in the instrument cluster display with the following driver message:

 **Low battery charge: battery will be charged while driving**

This notification reminds you that the starting capability of the engine may be limited. As soon as you start driving again, the battery will be recharged and the notification will go out.

### Driver notification appears and goes out again

If this driver notification appears after the ignition is turned on or while driving and it goes out again after a while, the battery has been adequately recharged.

### Driver notification appears and does not go out again

If this driver notification appears after the ignition is turned on or while driving and does not go out again, the battery's state of charge is not in the optimal range. Starting ability is restricted. Have the battery checked as soon as possible by an authorized Audi dealer or qualified workshop.

## Driving and environment

### The first 1,000 miles (1,500 km) and afterwards

#### New engine

The engine needs to be run-in during the first 1,000 miles (1,500 km).

#### For the first 600 miles (1,000 kilometers):

- ▶ Do not use full throttle.
- ▶ Do not drive at engine speeds that are more than 2/3 of the maximum permitted RPM.

#### From 600 to 1,000 miles (1,000 to 1,500 kilometers):

- ▶ Speeds can *gradually* be increased to the maximum permissible road or engine speed.

#### During and after break-in period

- ▶ Do not rev the engine up to high speeds when it is cold. This applies whether the transmission is in N (Neutral) or in gear.

#### After the break-in period

- ▶ Do not exceed maximum engine speed under any circumstances.
- ▶ Upshift into the next higher gear *before* reaching the red area at the end of the tachometer scale ⇒ *page 10*.

During the first few hours of driving, the engine's internal friction is higher than later when all the moving parts have been broken in. How well this break-in process is done depends to a considerable extent on the way the vehicle is driven during the first 1,000 miles (1,500 kilometers).

#### Note

Extremely high engine speeds are automatically reduced. However, these rpm limits are programmed for an engine well run-in, not a new engine.



#### For the sake of the environment

Do not drive with unnecessarily high engine speeds - upshifting early saves fuel, reduces noise and protects the environment.

#### New tires

If your vehicle is running on new tires, drive particularly careful for the first 350 miles (500 kilometers) after fitting.



#### WARNING

New tires tend to be slippery and must also be "broken-in". Be sure to remember this during the first 350 miles (500 kilometers). Brake gently. Avoid following closely behind other vehicles or other situations that might require sudden, hard braking.

#### New brake pads

Remember that new brake pads do not have a full braking effect during the first 250 miles (400 kilometers) after they are installed.

New brake pads have to be "burnished in" before they have optimal grab ⇒ .

During the break-in period, you should avoid putting severe loads on the brakes. Severe loads include, for example, sudden hard braking, in particular at very high speeds or, for example, on mountain passes.



#### WARNING

New brake pads don't have the best stopping power and must be "broken-in" during the initial 100 to 150 miles (150 to 200 kilometers) of normal city driving. You can compensate for this by pressing the brake pedal more firmly. This also applies later when new pads are installed.

## Catalytic converter

Applies to vehicles: with gasoline engine

*It is very important that your emission control system (catalytic converter) is functioning properly to ensure that your vehicle is running in an environmentally sound manner.*

- ▶ Always use lead-free gasoline ⇒ *page 256, Gasoline.*
- ▶ Never run the tank down all the way to empty.
- ▶ Never put too much motor oil in your engine ⇒ *page 270, Adding engine oil* .
- ▶ Never try to push- or tow-start your vehicle.

The catalytic converter is an efficient “clean-up” device built into the exhaust system of the vehicle. The catalytic converter burns many of the pollutants in the exhaust gas before they are released into the atmosphere.

The exclusive use of unleaded fuel is critically important for the life of the catalytic converter and proper functioning of the engine.

### WARNING

- Do not park or operate the vehicle in areas where the hot exhaust system may come in contact with dry grass, brush, fuel spill or other material which can cause a fire.
- Do not apply additional undercoating or rustproofing on or near the exhaust manifold, exhaust pipes, catalytic converter or heat shields. During driving, the substance used for undercoating could overheat and cause a fire.

### Note

- Be aware that just one tank filling with **leaded** fuel will already seriously degrade the performance of the catalytic converter.
- Do not exceed the correct engine oil level ⇒ *page 270.*
- Do not drive until the fuel tank becomes completely empty. The engine could misfire. Unburned fuel could also get into

the exhaust system and this could cause the catalytic converter to overheat.

- Do not turn off the ignition while the vehicle is moving.
- Do not continue to operate your vehicle under these conditions, as otherwise fuel can reach the catalytic converter. This could result in overheating of the converter, requiring its replacement.
- To assure efficient operation of the Emission Control System:
  - Have your vehicle maintained properly and in accordance with the service recommendations in your Warranty & Maintenance booklet.
  - Lack of proper maintenance as well as improper use of the vehicle will impair the function of the emission control system and could lead to damage.



### For the sake of the environment

Even when the Emission Control System is operating properly, the exhaust gas can have a sulfur-like exhaust gas smell under some operating states. This depends on the sulfur content of the fuel being used. Using a different brand of fuel may help, or filling the tank with lead-free super grade gasoline.

## Diesel particulate filter

Applies to vehicles: with diesel engine

The diesel particulate filter filters nearly all of the soot particles out of the exhaust. The filter cleans itself automatically under normal driving conditions. If the filter cannot clean itself (for example, because you are only driving short distances), the filter becomes clogged with soot and the  symbol for the diesel particulate filter illuminates ⇒ *page 37.*



### WARNING

- Do not park your vehicle over flammable materials such as grass or leaves because the high temperature of the diesel particulate filter could start a fire.

- Do not apply an underbody protectant in the exhaust system area or a fire could start.

## Avoid damaging the vehicle

When you are driving on poor roads, or over curbs, steep ramps, etc., make certain that low-lying parts such as spoilers and exhaust system parts do not bottom out and get damaged.

This is especially true for vehicles with low-slung chassis (sports chassis)\* and fully loaded vehicles.

## Operate your vehicle economically and minimize pollution

### General

*Your personal style of driving will determine the economy of your vehicle, as well as exhaust and noise levels.*

Fuel economy, environmental impact, and wear on your engine, brakes and tires largely depend on three factors:

- your personal driving style
- operating conditions
- technical limitations

If you anticipate what you need to do next and drive economically, you can easily cut your fuel consumption by 10-15 percent. This section will give you some tips on how you can help the environment and your pocketbook.

### Tips

The consumption estimates as published by ENVIRONMENTAL PROTECTION AGENCY (EPA) and Transport Canada may not correspond to your actual consumption on the road, which will vary depending upon vehicle load and speed, road and weather conditions, trip length, etc.

### Drive smoothly and keep a lookout ahead

*Vehicles use the most fuel when they are accelerating.*

- ▶ Avoid unnecessary accelerating and braking.

Vehicles use the most fuel when they are accelerating. If you anticipate what is going to happen next, you will need to brake less and, thus, accelerate less. Let the vehicle coast whenever possible - for example when you see that the next traffic light is red.

### Avoid full throttle

*Driving at moderate speeds saves fuel and improves your mileage.*

- ▶ Try and keep well below your car's maximum speed.

Accelerating gently reduces fuel consumption, engine wear, and does not disturb the environment.

Fuel consumption, exhaust emissions and engine noise increase disproportionately at high speeds. If you drive at approximately three quarters of top speed, fuel consumption will be reduced by one half. Never drive faster than the posted speed limit and weather conditions permit.

### Reducing unnecessary idling

*Even when your car is just idling it burns up fuel.*

- ▶ Shut the engine off when you are not driving the vehicle.
- ▶ Do not warm up the vehicle by letting the engine run at idle.

It makes sense to shut off the engine in traffic jams, when waiting for trains to pass at railroad crossings, or at traffic lights that have long waits on red. Turning the engine off for just 30-40 seconds saves more fuel than is burned starting the engine again. ▶

It takes a long time for the engine to warm up fully when it is running at idle. However, wear and noxious emissions are especially high when the engine is warming up. So you should drive away as soon as you start the engine and avoid running at high rpms while the engine is still warming up.

### Note

Do not leave engine idling unattended after starting. If warning lights should come on to indicate improper operation, they would go unheeded. Extended idling also produces heat, which could result in overheating or other damage to the vehicle or other property.

## Regular maintenance

*A badly tuned engine unnecessarily wastes a lot of fuel.*

- ▶ Have your vehicle serviced at regular intervals.

By having your vehicle regularly serviced by an authorized Audi dealer helps to ensure that it runs properly and economically. The condition of your vehicle not only affects its safety and ability to hold its value, it also affects **fuel consumption**.

### Check your oil each time you fill your tank.

The amount of oil used is related to engine load and speed.

It is normal for the oil consumption of a new engine to reach its lowest value after a certain mileage has been driven.

You must drive your vehicle about 3,000 miles (5,000 kilometers) before you can properly assess oil consumption.

This also applies to fuel consumption and engine output.

### Note

- Have your vehicle maintained properly and in accordance with the service recommendations in your Warranty & Main-

tenance booklet. Lack of proper maintenance as well as improper use of the vehicle will impair the function of the emission control system and could lead to damage.

- Do not alter or remove any component of the Emission Control System unless approved by the manufacturer.
- Do not alter or remove any device, such as heat shields, switches, ignition wires, valves, which are designed to protect your vehicle's Emission Control System and other important vehicle components.

## Fewer short trips

*Fuel consumption will always be relatively high on short trips.*

- ▶ Try to avoid driving short distances with a cold engine.

The engine and catalytic converter have to reach their optimal **operating temperature** to reduce fuel consumption and noxious emissions effectively.

Just after starting, a cold engine in a mid-size car only achieves a fuel economy of 6-8 miles per gallon (30-40 l/100km). After about a half a mile, fuel economy climbs to 12 mpg (20 l/100 km). After about 2.5 miles (4 km), the engine is at its proper operating temperature and fuel economy has reached a normal level. So you can see that you should avoid short trips whenever possible.

The **outside temperature** is also critical in this regard. Your car consumes more fuel in the winter than in the summer.

## Driving off road

### Driving in difficult road conditions and offroad

#### General information

The operation of the Electronic Stabilization Control (ESC) is expanded for operation away from paved roads. In situations where slip or a differential locking function is required, the ESC offroad mode can be activated

⇒ *page 225*. Hill descent control is also available in the ESC offroad mode, which automatically brakes the vehicle and thereby keeps speed constant when different wheel speeds are detected when descending a hill  
⇒ *page 226*. Your Audi also has permanent all-wheel drive in addition.

However, your Audi is not a pure offroad vehicle. It was not built for driving under extreme conditions, e.g. for trips that are in the nature of an expedition.

**Drive only on roads and offroad sections which match the design of your vehicle and your abilities as a driver. Never take risks!**

#### Before driving offroad

- Check the engine oil level, tire pressure, coolant level, and the fluid level in the windshield washer reservoir.
- Stow luggage items and other objects in the luggage compartment, and secure them against sliding around.

#### After driving offroad

- After trips offroad, remove any twigs and other foreign objects from the grill, the underbody and the wheels. Pay special attention to foreign objects (stones) which have become lodged in the tire tread.
- Clean the body and the vehicle underside, and inspect the vehicle for possible damage.
- Clean dirty windows, headlamp lenses, rear lights, and license plates.
- Perform a brake check (particularly after travelling through water).

#### WARNING

- Drive especially attentively and plan ahead in difficult road conditions and when offroad. Excessive speed or incorrect maneuvers can cause injuries and damage to the vehicle.
- Always adapt your speed and driving style to road, offroad, traffic, and weather conditions. Drive especially slowly offroad when your view is restricted.
- Please be aware that in ESC offroad mode, particularly on a smooth and slippery road, the wheels may have an increased tendency to spin and the vehicle may break away - danger of skidding!
- Stability is limited in the ESC offroad mode.

#### For the sake of the environment

Avoid damage to the environment and respect nature.

#### Tips

Only drive where it is permitted and stay on marked roads and paths.

#### Explanation of some technical terms

The following data refer to ideal conditions. Depending on vehicle load and ground conditions and the environment, the numbers may vary. It is the driver's responsibility to decide whether a vehicle can overcome a specific situation ⇒ .

#### Gradient angle

The number of meters in altitude gained over a distance of 109.4 yards or 100 meters (grade) are given as a percentage or degrees. Information about the gradient the vehicle can climb under its own power (depends in part on the road surface and engine power).  
Maximum permitted grade: 31°

#### Lateral angle (slope of vehicle)

Indicates the angle up to which the vehicle can be driven diagonally or across the fall line ►

on a slope without the vehicle tipping over sideways (depends on center of gravity). Maximum permitted lateral angle: 35°

### Breakover angle

Indicates the angle up to which the vehicle can drive over a ramp at low speed without the underside of the vehicle hitting the edge of the ramp.

- **Vehicles without air springs:** maximum breakover angle: 21,1°
- **Vehicles with adaptive air suspension\*:** maximum breakover angle: 23.8° (at high level 2)

### Approach/departure angle

Transition from the horizontal plane to a gradient or from a grade back to level ground. Indicates the angle up to which the vehicle can drive onto or off a slope at low speed without striking the bumper or the underbody.

- **Vehicles without air springs:** maximum approach/departure angle: 21.0° (front), 23.4° (rear)
- **Vehicles with adaptive air suspension\*:** maximum approach/departure angle at high level 2: (front) 23,5°, (rear) 25.4°

### Ground clearance

The distance between the road surface and the lowest point of the vehicle underbody.

- **Vehicles without air springs:** ground clearance: 8.1 in (204.8 mm)
- **Vehicles with adaptive air suspension\*:** maximum ground clearance: 9.4 in (239.8 mm) at high level 2

#### WARNING

Exceeding the stated maximum figures can result in severe injuries or vehicle damage.

- All the information was gathered on level, firm and non-slippery road surfaces, and under dry weather conditions.
- Ideal conditions do not prevail offroad. Never utilize the maximum readings to

their fullest, always leave a safety reserve.

### Driving tips

*On poor road and offroad, there is always only one motto: Plan ahead and drive slowly!*

Please observe the following when driving away from paved roads:

- ▶ Drive only on roads and offroad sections which match the design of your vehicle and your abilities as a driver. Never take risks!
- ▶ Drive slowly and plan ahead!
- ▶ Take into consideration the **ground clearance** of your vehicle.
- ▶ Activate the **ESC offroad mode** ⇒ page 225 as needed.
- ▶ Use the **hill descent control** ⇒ page 226 when driving down steep sections on hills.

### Unpaved roads and offroad

Drive slowly on unfamiliar roads and unknown offroad sections, and look out for unexpected obstacles (e.g. potholes, rocks, tree stumps, etc.).

To prevent the vehicle from bottoming and avoid damage to the underbody, you should drive straight across severe bumps in the ground with only one side of the vehicle so that only two of your wheels cross the bumps.

Drive briskly through sandy or marshy offroad sections and do not stop, if at all possible.

### Driving through water

Note the following to avoid vehicle damage when driving through water, for example on flooded roads:

- The water must not be any higher than the bottom of the vehicle body.
- Do not drive faster than walking speed.

### Driving on a slope

If you ever find yourself **not** able to climb a slope, do not try to turn around, drive back down in **reverse**. Otherwise, you run the risk of tipping over.

If the vehicle threatens to tip over when driving across a slope, you must immediately steer downhill in the direction of the slope.

Do **not** park your vehicle on steep slopes or grades.

To reduce the risk of tipping over, drive on slopes in the direction of the downward slope (fall line) - **not crosswise**.

 **WARNING**

After driving through water, mud, slush, etc., the brakes may be slow to take effect because of wet brake rotors and pads. Dry the brakes first by braking carefully to restore the full braking effect.

 **Note**

Vehicle components such as the engine, transmission, suspension or electrical system can be severely damaged by driving through water.

 **Tips**

- Check the depth of the water before driving through it.
- Do not stop the vehicle, drive in reverse or switch the engine off when driving through water.
- Keep in mind that oncoming vehicles may create waves that raise the water level and make it too deep for your vehicle to drive through safely.
- Avoid driving through salt water because it can cause corrosion.

## Trailer towing

### Driving with a trailer

#### General information

Your Audi was designed primarily for passenger transportation.

If you plan to tow a trailer, please remember that the additional load will affect durability, economy and performance.

Trailer towing not only places more stress on the vehicle, it also calls for more concentration from the driver.

For this reason, always follow the operating and driving instructions provided and use common sense.

#### Note

If you are going to tow a trailer, you must activate the trailer operation mode  
⇒ page 159, *Towing a trailer*.

#### Technical requirements

##### Trailer hitch

Use a weight-carrying hitch conforming to the gross trailer weight. The hitch must be suitable for your vehicle and trailer and must be mounted securely on the vehicle's chassis at a *technically sound* location. Use only a trailer hitch with a removable ball mount. Always check with the trailer hitch manufacturer to make sure that you are using the correct hitch.

##### Do not use a bumper hitch.

The hitch must be installed in such a way that it does not interfere with the impact-absorbing bumper system. No modifications should be made to the vehicle exhaust and brake systems. From time to time, check that all hitch mounting bolts remain securely fastened.

When you are not towing a trailer, remove the trailer hitch ball mount. This prevents the hitch from causing damage should your vehicle be struck from behind ⇒ .

##### Trailer brakes

If your trailer is equipped with a braking system, check to be sure that it conforms to all regulations.

The trailer hydraulic brake system must not be directly connected to the vehicle's hydraulic brake system ⇒ .

##### Safety chains

Always use safety chains between your vehicle and the trailer.

##### Trailer lights

Trailer lights must meet all regulations. Be sure to check with your authorized Audi dealer for correct wiring, switches, and relays.

##### Mirrors

If you are unable to see the traffic behind you using the regular outside mirrors, then you *must* install extended mirrors. It is important that you *always* have clear vision to the rear.

#### WARNING

- If a trailer has electrical brakes please note that these brakes are not activated by the factory-fitted control unit - risk of accident!
- After removing the trailer hitch, do not store it in your vehicle. In case of sudden braking, the hitch could fly forward and injure you or your passengers.
- Never install a “weight distributing” or “load equalizing” trailer hitch on your vehicle. The vehicle was not designed for these kinds of trailer hitches. The hitch attachment can fail, causing the trailer to tear loose from the vehicle.
- The Gross Vehicle Weight Rating for your vehicle, found on the safety compliance label on the driver's side B-pillar, must never be exceeded under any circumstances. Exceeding the Gross Vehicle Weight Rating of your vehicle is likely to damage your vehicle, and such damage will not be covered by your Limited New Vehicle Warranty. Exceeding the Gross Vehicle

Weight Rating will also change the performance and handling characteristics of your vehicle, which could cause a crash resulting in serious injury or death.

- The Gross Vehicle Weight Rating for your vehicle would be exceeded if your vehicle is simultaneously equipped with Panoramic sliding sunroof; third-row seating; trailer towing equipment (factory or dealer-installed), and running boards (dealer-installed). UNDER NO CIRCUMSTANCES MAY ALL SUCH ITEMS BE INSTALLED ON THE SAME VEHICLE.

### Operating instructions

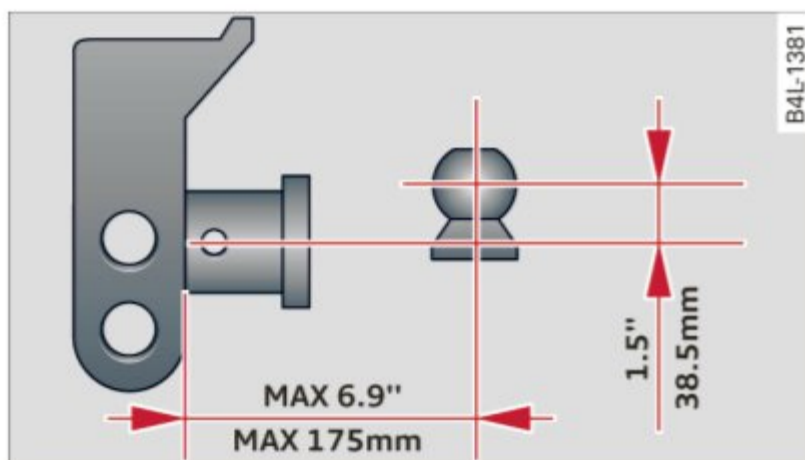

Fig. 233 Permitted ball position of the trailer hitch

### Trailer towing weights

With a **factory-installed** trailer hitch, the maximum permissible trailer weight is 6,615 lbs (3,000 kg). The maximum permissible unbraked trailer weight is 1,650 lbs (750 kg). With an **aftermarket** trailer hitch, the maximum permissible trailer weight is 5,512 lbs (2,500 kg). These specifications apply when driving on roads having an incline of less than 12%.

### Permissible tongue load

For best vehicle handling under these changed conditions, adjust the trailer load so that the tongue load is at the maximum allowable or slightly lower. You can get an approximation of the tongue load with a bathroom scale or you can measure the load at a trucking company or weighing station.

With a **factory-installed** trailer hitch, the maximum permissible load on the ball hitch

may not exceed 662 lbs (300 kg). With an **aftermarket** trailer hitch, the maximum permissible load on the ball hitch may not exceed 551 lbs (250 kg). It is recommended to use the maximum permissible load.

### Trailer load distribution

Be sure the load in the trailer is held securely in place to prevent it from shifting forward, backward or sideways.

### Never allow a passenger to ride in a trailer

⇒ ⚠ in *Driving instructions* on page 243.

### Ball mount

The trailer hitch may only be used with suitable ball mount and ball ⇒ *fig. 233*. Installation of the hitch ball must be carried out in accordance with the manufacturer's instructions. At the height dimension of 1.5 in (38.5 mm) a tolerance of +/- 0.5 in (12.7 mm) is permissible.

### Engine cooling system

Towing a trailer makes the engine work harder. It is important that the cooling system's performance is up to the additional load. Make sure that the cooling system has enough fluid.

### Tire pressure

When towing a trailer, inflate the tires of your vehicle to the cold tire pressure listed under "Full load" on the tire pressure label. The tire pressure label is located on the driver's side B-pillar. Inflate trailer tires to trailer and tire manufacturers' specifications.

### Lights

The headlight settings should be checked with the trailer attached before driving off. Check to make sure both vehicle and trailer lights are working properly.

### Safety chains

Be sure trailer safety chains are properly connected from the trailer to the hitch on the vehicle. Leave enough slack in the chains to permit turning corners. When you install safety

chains, make sure they will not drag on the road when you are driving.

The chains should cross under the trailer tongue to prevent it from dropping in case of separation from the hitch.

### Note

If you are going to tow a trailer, you must activate the trailer operation mode  
⇒ page 159, *Towing a trailer*.

## Driving instructions

*Driving with a trailer always requires extra care and consideration.*

To obtain the best possible handling of vehicle and trailer, please note the following:

- ▶ Do not tow a loaded trailer when your car itself is not loaded.
- ▶ Be especially careful when passing other vehicles.
- ▶ Observe speed limits.
- ▶ Do not drive at the maximum permissible speed.
- ▶ Always apply brakes early.
- ▶ Monitor the temperature gauge.

## Weight distribution

Towing a loaded trailer with an empty car results in a highly unstable distribution of weight. If this cannot be avoided, drive at very low speeds only to avoid the risk of losing steering control.

A “balanced” rig is easier to operate and control. This means that the tow vehicle should be loaded to the extent possible and permissible, while keeping the trailer as light as possible under the circumstances. Whenever possible, transfer some cargo to the luggage compartment of the tow vehicle while observing tongue load requirements and vehicle loading considerations.

## Speed

The higher the speed, the more difficult it becomes for the driver to control the rig. Do not drive at the maximum permissible speed. Re-

duce your speed even more if load, weather or wind conditions are unfavorable - particularly when going downhill.

Reduce vehicle speed **immediately** if the trailer shows the slightest sign of swaying. **Do not try to stop the swaying by accelerating.**

Observe speed limits. In some areas, speeds for vehicles towing trailers are lower than for regular vehicles.

Always apply brakes early. When driving downhill, shift into a lower gear to use the engine braking effect to slow the vehicle. Use of the brakes alone can cause them to overheat and fail.

## Coolant temperature

The coolant temperature gauge ⇒ page 10 must be observed carefully. If the needle moves close to the upper end of the scale, reduce speed immediately and/or turn off the air conditioner.

If the coolant temperature warning light in the instrument cluster starts flashing , pull off the road, stop and let the engine *idle* for about two minutes to prevent heat build-up.

### WARNING

Anyone not properly restrained in a moving vehicle is at a much greater risk in an accident. Never let anyone ride in your car who is not properly wearing the restraints provided by Audi.

## Trailer towing tips

### Important to know

Your vehicle handles differently when towing a trailer because of the additional weight and different weight distribution. Safety, performance and economy will greatly depend on how carefully you load your trailer and operate your rig.

Before you actually tow your trailer, practice turning, stopping and backing up in an area away from traffic. Keep practicing until you

have become completely familiar with the way your vehicle-trailer combination behaves and responds.

Backing up is difficult and requires practice. Backing up with a trailer generally requires steering action opposite to that when backing up your vehicle without a trailer.

Maintain a greater distance between your vehicle and the one in front of you. You will need more room to stop. To compensate for the trailer, you will need a larger than normal turning radius.

When passing, remember that you cannot accelerate as fast as you normally would because of the added load. Make sure you have enough room to pass. After passing, allow plenty of room for your trailer before changing lanes again.

Avoid jerky starts, sharp turns or rapid lane changes.

### **i** Tips

- Do not tow a trailer during the break-in period of your vehicle.
- If you tow a trailer, your Audi may require more frequent maintenance due to the extra load ⇒ *page 325*.

### **Parking on a slope**

*Do not park on a slope with a trailer. If it cannot be avoided, do so only after doing the following:*

#### **When parking:**

- ▶ Apply the foot brake.
- ▶ Have someone place chocks under both the vehicle and the trailer wheels.
- ▶ With chocks in place, slowly release the brakes until the wheel chocks absorb the load.
- ▶ Turn the wheels towards the curb.
- ▶ Apply the parking brake.
- ▶ Move the selector lever to **P**.

#### **When restarting after parking:**

- ▶ Apply the foot brake.

- ▶ Start the engine.
- ▶ Move the selector lever to **D**.
- ▶ Release the parking brake and slowly pull out and away from the wheel chocks.
- ▶ Stop and have someone retrieve the wheel chocks.

### **i** Tips

If you move the selector lever of the automatic transmission to **P** before applying the parking brake and before blocking the wheels, you may have to use more force later to move the lever out of the **P** position.

## Cleaning and protection

### General information

*Regular care preserves vehicle value.*

Any automobile is exposed to industrial fumes, corrosive road salt, etc. A well cared for Audi can look like new many years after purchase. Regular and correct care will contribute to maintaining the beauty and value of your Audi.

**Furthermore, good care may be a condition for substantiating a warranty claim should corrosion damage or paint defects occur.**

Your authorized Audi dealer has a variety of **dedicated vehicle-care products** and can advise which ones to use for cleaning the exterior and interior of your vehicle.

Whether you use products recommended by Audi or other commercially available cleaning agents, please make sure you apply them correctly.

#### WARNING

- Cleaning agents may be poisonous. Keep them out of the reach of children.
- Heed all caution labels.
- Always read directions on the container before using any product. Follow the directions carefully.
- Most chemical cleaners are concentrated and have to be diluted.
- Use spot removing fluids only in well ventilated areas.
- Do not use gasoline, kerosene, diesel fuel, nail polish remover or other volatile fluids. They may be toxic, flammable or hazardous in other ways. Do not wash, wax or dry the vehicle with the ignition on or the engine running.
- Do not clean the undersides of chassis, fenders, wheel covers, etc. without protecting your hands and arms. You may cut yourself on sharp-edged metal parts.

- Moisture and ice on brakes may impair braking efficiency ⇒ *page 228, General information*. Test the brakes carefully each time you wash the vehicle.



#### For the sake of the environment

Select only environmentally friendly cleaning products. Leftover cleaning products should not be disposed of in the household waste.

### Care of exterior

#### Washing

*Frequent washing protects the vehicle.*

The best protection against environmental influences is *frequent* washing and waxing. How often this is required depends on:

- How much the vehicle is used
- Where the vehicle is parked (garage, in the open under trees, etc.)
- The seasonal and weather conditions
- Environmental influences

The longer bird droppings, insects, tree resin, road and industrial grime, tar, soot, road salt and other materials remain on the vehicle body, the more lasting their destructive effects will be. High temperatures caused by exposure to intense sunlight intensify the corrosive effect, particularly when humidity is high as well.

Under certain circumstances, **weekly** washing may be necessary. Under other conditions, a monthly washing and waxing may be adequate.

After the winter, the underside of the vehicle should be thoroughly washed, preferably in a professional car wash.



#### WARNING

Always read and heed all WARNINGS and other information ⇒ *page 245*.

**Automatic car wash**

*The vehicle can be washed in almost any modern automatic car wash.*

The vehicle paint is so durable that the vehicle can normally be washed without problems in an automatic car wash. However, the effect on the paint depends to a large extent on the design of the facility, the filtering of the wash water, the type of wash and care material, etc. If the paint has a dull appearance after going through the car wash or is scratched, bring this to the attention of the operator immediately. If necessary, use a different car wash.

Before going through a car wash, be sure to take the usual precautions such as closing the windows and the Panoramic sliding sunroof. Factory installed antennas must not be removed.

If you have installed additional accessories on the vehicle - such as spoilers, roof rack, etc. - it is best to ask the car wash operator if these should be removed.

**! WARNING**

Please take note of the following points before going through an automatic car wash with your vehicle, so that you can avoid damage to your vehicle.

- Compare the track of your vehicle with the distance between the guide rails of the facility - there is a risk of damage to the wheels and tires.
- Compare the height and width of your vehicle with the height and width of the tunnel at the facility.
- Fold the exterior mirrors flat - there is a risk of damaging the exterior mirrors. Power folding exterior mirrors\* must not be folded in or out by hand. Use the power function!
- Do not allow the wiper blade to fall onto the windshield after the vehicle is dried - there is a risk of damaging the paint on the hood.
- Always read and heed all WARNINGS and other information ⇒ *page 245*.

**Washing the vehicle by hand**

*A lot of water is needed when washing a vehicle by hand.*

- ▶ Before you start washing, make sure you have read and understood the WARNINGS ⇒  *in General information on page 245.*
- ▶ First soak all dried dirt until it is soft, then rinse it off.
- ▶ As you clean your vehicle, start with the roof and work your way down to the bottom, using a sponge, a sponge glove or a clean brush.
- ▶ Rinse the sponge or the sponge glove often, flushing it clean each time.
- ▶ Use special car shampoo only for very persistent dirt.
- ▶ Rinse the car thoroughly with water.
- ▶ Use a chamois leather to gently wipe the exterior dry.

Use a separate sponge for cleaning the wheels, door sills and other regions exposed to road dirt. In this way, you will not scratch the paint with coarse particles imbedded in the sponge the next time you wash the car.

**! WARNING**

- Do not clean the underside of the chassis, fenders, wheel covers, or other hard to reach parts without protecting your hands and arms. You may cut yourself on sharp-edged metal parts.
- Always read and heed all WARNINGS and other information ⇒ *page 245*.

**! Note**

- Never try to remove dirt, mud or dust if the surface of the vehicle is dry. Never use a dry cloth or sponge, since this could scratch your vehicle's paint or windows.
- Never wash your car in bright sunlight. Drops of water act as magnifying lenses and may damage your paint.
- When you wash your car in the winter: if you rinse your vehicle with a hose, be careful not to aim the stream of water

directly at locks, or at door or hatch openings - they can freeze shut.

- Never use sponges designed to remove insects, or any kitchen scouring sponges or similar products. They can damage your paint finish.
- You should remove debris (such as insects) from the headlight lenses on a regular basis, for example when refueling your vehicle. Never use a dry cloth or sponge to clean the headlights. Only use wet cloths or sponges to prevent scratches. It is best to use soapy water.



### For the sake of the environment

In the interest of the environment, the vehicle should only be washed in special wash bays.

## Washing your vehicle with a power washer

*Cleaning the exterior of your car with a high-pressure power washer is safe as long as you observe a few simple rules.*

- ▶ Before using the power washer, make sure you have read and understood the WARNINGS ⇒  in *General information on page 245*.
- ▶ Always follow the operating instructions for the power washer.
- ▶ Make sure that the jet on the spray hose produces a “fan shaped spray”.
- ▶ Do *not* hold the spray nozzle *too close* to soft materials.

When cleaning the vehicle with a power washer *always* follow the operating instructions. This applies particularly to the **operating pressure** and the **spraying distance**. Maintain a sufficient distance to soft materials such as rubber hoses and sound/vibration deadening materials (particularly on the underside of the engine hood). Do not use a jet which sprays water in a **direct stream** or one that has a **rotating jet**.

Water temperature should not exceed 140 °F (60 °C).



### WARNING

Never wash tires with a jet that sprays water in a direct stream. This could cause invisible damage to the tires and weaken them, even if the spray is from a relatively long distance and for a short time. Damaged and weakened tires can fail and cause accidents and personal injury.



### Note

To avoid damaging your vehicle, always make sure that there is sufficient distance between the spray head and soft materials like rubber hoses, plastic parts and sound-deadening materials. Never aim the spray head at the same point for a long time. This also applies to cleaning headlights and painted bumpers. Remember: the closer the nozzle is to the surface of the material, the greater the stress on the material.

## Sensors and camera lenses

- Remove snow with a hand brush and remove ice with a de-icing spray that does not contain solvents.
- Clean the sensors (adaptive cruise control\*, parking system\*) with a cleaning solution that does not contain solvents and a soft cloth.
- Dampen the camera lens with a household alcohol-based glass cleaner, and then wipe the lens clean with a dry cloth.



### Note

- If you wash your vehicle with a pressure washer,
  - make sure there is enough distance to sensors in the rear bumper.
  - do not clean the camera lenses and the area around them with the pressure washer.
- Never use warm or hot water to remove snow or ice from the camera lens. This could cause the lens to crack.

– Never clean the camera lens with abrasive products.

## Waxing and Polishing

### Waxing

A good wax coating protects the vehicle paint to a large extent against the environmental factors listed under ⇒ *page 245, Washing* and even against slight scratches.

You can use a liquid car wax to protect your paint as soon as one week after your vehicle has been delivered.

Even if you regularly use a **waxing** process in automatic car washes, we recommend that you manually apply a coat of wax to give the paint extra protection, particularly if water no longer beads on the clean paint.

Protect plastic body parts with car wax in the same way as the vehicle body.

During warm weather dead insects tend to collect on the front bumper and on the forward area of the hood. They are much easier to remove from paint that is waxed *often*.

### Polishing

Polish your vehicle only if the paint has lost its shine and the gloss cannot be brought back with wax.

If the polish used does not contain preservative compounds, the paint must be waxed afterwards.

#### **WARNING**

Always read and heed all WARNINGS and other information ⇒ *page 245*.

#### **Note**

Do not use car wax on  
– matte or anodized metal trim  
– rubber or rubber-like trim.

## Trim strips

*Metal trim needs special care.*

For environmental reasons, Audi fabricates the bright trim strips and trim pieces from pure chromium-free aluminum.

Dirt and marks on the trim strips should be removed with a **pH-balanced** cleaning agent (do not use a chrome cleaner). Authorized Audi dealers carry cleaning products which have been tested for use on your vehicle and are not harmful to the environment.

To avoid corrosion on the exterior trim strips, only a pH-balanced solution should be used for the windshield washer.

#### **WARNING**

Always read and heed all WARNINGS and other information ⇒ *page 245*.

## Plastic and vinyl

*Plastic needs special care.*

Use a clean, damp cloth or sponge to remove dust and light surface dirt. For other soil, use a lukewarm all-purpose cleaning solution or a mild saddle soap for vinyl trim. Remove water spots and traces of soap with a clean, damp cloth or sponge. Use a clean, soft cloth to rub dry.

Grease, tar or oil stains can be removed with a clean cloth or sponge soaked with all-purpose cleaner or with a solvent designed especially to clean vinyl.

Occasionally apply a colorless vinyl or leather preservative to retain the material's luster and pliability.

#### **WARNING**

Always read and heed all WARNINGS and other information ⇒ *page 245*.

## Aluminum trim

Use only **neutral-pH** products to remove spots and deposits from aluminum surfaces. ►

Chrome care products and alkaline cleaners will attack aluminum surfaces and can damage them over time.

### WARNING

Always read and heed all WARNINGS and other information ⇒ *page 245*.

## Touch-up paint

*Minor paint damages should be touched up immediately.*

- ▶ Use either a touch-up paint stick or spray paint to cover minor scratches and nicks.

Your authorized Audi dealer has touch-up paint for minor scratches and stone chips. Scratches should be touched up soon after they occur to prevent corrosion.

If a spot starts to rust, however, a simple touch-up job will not be enough. The affected surface must be sanded smooth and coated with an anti-rust primer before the painted finish can be restored.

The number for the original vehicle paint can be found on the vehicle identification label ⇒ *page 320*.

### WARNING

Always read and heed all WARNINGS and other information ⇒ *page 245*.

## Windows

*Clear vision to all sides.*

Clean all windows regularly to remove road film and carwash wax buildup.

- ▶ Remove snow from windows using a brush.
- ▶ Use a plastic ice scraper to remove ice from windows and mirrors.
- ▶ Remove other residue on the windows with a spray-on glass cleaner.
- ▶ Wipe the windows dry with a clean piece of cloth or kitchen paper towel.

The best way to remove snow from windows and mirrors is to use a brush. Use a non-abrasive **plastic ice scraper** - better still, a spray deicer - to remove **ice** from windows and mirrors.

The windows must not be cleaned with insect remover or wax since these can interfere with the function of the windshield wiper blades (chatter).

Oil, grease, or silicone residue can be removed with **glass cleaner** or **silicone remover**. However, wax residue requires the use of a specially formulated solvent. Please contact your authorized Audi dealer for advice on safe products for wax removal.

Windows should also be cleaned on the inside at regular intervals.

Never dry windows with the same chamois that you use to dry painted surfaces. Wax residue on the chamois can impair vision through the windows.

### WARNING

- Always read and heed all WARNINGS and other information ⇒ *page 245*.
- The windshield must not be treated with water-repellent materials. They can increase glare under poor visibility conditions such as wetness, darkness, or when the sun is low on the horizon. In addition, they can cause the windshield wipers to chatter.

### Note

- Never use warm or hot water to remove snow and ice from windows and mirrors. This could cause the glass to crack.
- To prevent damage to the wires of the rear defogger, do not place any adhesive stickers on the inside of the rear window over the wires.
- To help prevent dirt from scratching the window, always scrape in a forward direction - pushing the scraper away from you - never back and forth.

**Cast (light) alloy wheels**

*Cast (light) alloy wheels require special care.*

- ▶ Wash the wheels with a sponge or hose brush every other week.
- ▶ For deep cleaning afterwards, use only a dedicated **acid-free** cast alloy wheel cleaner.
- ▶ Rub a coat of **liquid wax** onto the rims every three months. Be sure to reach and treat all parts of the rim.

To preserve the decorative appearance of the cast alloy wheels, some special care is necessary. In addition to road dirt and salt, brake dust is also corrosive. If left on for too long, brake dust can cause pitting.

Use only special *acid-free* cleaners formulated for alloy rims. Safe products are available at your authorized Audi dealer. Never leave the cleaner on the rims longer than specified on the label. If not rinsed off promptly, the acid contained in some cleaners can attack the threads on the wheel bolts.

Never use abrasive or metal polishing cleaning agents. If the protective coating has been chipped, e.g. by kicked up road dirt, touch it up as soon as possible.

**! WARNING**

- Moisture and ice on brakes may affect braking efficiency ⇒ *page 228, General information*. Test the brakes carefully each time you wash the vehicle.
- Always read and heed all WARNINGS and other information ⇒ *page 245*.

**Body cavity sealing**

*The body cavity sealing does not need to be checked.*

All body cavities which could be affected by corrosion have been thoroughly protected at the factory.

This sealing does not require any inspection or additional treatment. If any wax should seep out of the cavity when the ambient tempera-

ture is high, it can be removed with a plastic scraper and a suitable solvent.

**! WARNING**

- Solvents can be dangerous.
- Benzine is flammable and toxic. If you use benzine for removing the wax, keep sparks, flame and lighted cigarettes away. Never dump benzine on the ground, into open streams or down sewage drains.
  - Be sure to observe all safety and environmental regulations. Follow all instructions on the container.
  - Always read and heed all WARNINGS and other information ⇒ *page 245*.

**Chassis**

*Have the undercoating checked for damage from time to time.*

The lower body shell of your Audi is also thoroughly protected against corrosion.

Any damage to the undercoating caused by road hazards should be repaired promptly.

**! WARNING**

- Too much undercoating in the wrong places can cause a fire.
- Do not apply additional undercoating or rustproofing on or near the exhaust manifold, exhaust pipes, catalytic converter or heat shields. While driving, the substance used for undercoating could overheat and cause a fire.
  - Always read and heed all WARNINGS and other information ⇒ *page 245*.

**Exhaust tail pipes**

Road salt and other corrosive materials will damage the material in the exhaust tail pipes if they are not cleaned regularly. Do not clean the tail pipes with wheel cleaner, paint polish, chrome polish or other abrasive cleaners. Clean the tail pipes with car care products that are suitable for stainless steel. ▶

Your authorized Audi dealer can provide cleaning products that have been tested and approved for your vehicle.

## Care of interior

### MMI display

- ▶ Clean the MMI display with a soft clean cloth and an LCD cleaner.

The MMI display can be cleaned with a professionally available "LCD cleaner". The cloth should be slightly dampened with the cleaning fluid to clean the display.

#### Note

To avoid scratching the MMI display, you should never clean it dry.

### MMI control console

- ▶ First clean the MMI control console with a brush to remove dust from the housing.
- ▶ Then wipe the MMI control console with a clean, soft, slightly damp cloth.

The MMI control console should be cleaned with a brush first so that no dirt is trapped between the buttons and the housing. We recommend giving the MMI control console a final wipe with a cloth moistened with water and dish washing detergent.

#### Note

To prevent damage, make sure that no fluid ever gets into the MMI control console.

### Aluminum trim

Use only **neutral-pH** products to remove spots and deposits from aluminum surfaces. Chrome care products and alkaline cleaners will attack aluminum surfaces and can damage them over time.

#### WARNING

Always read and heed all WARNINGS and other information ⇒ *page 245*.

### Fabrics and fabric coverings

Fabrics and fabric coverings (e.g. seats, door trim panels, etc.) should be cleaned at regular intervals with a vacuum cleaner. This removes surface dirt particles which could become embedded in the fabric through use. Steam cleaners should not be used, because the steam tends to push the dirt deeper into the fabric and lock it there.

#### Normal cleaning

Generally, we recommend using a soft sponge or a lint-free microfiber cloth to clean fabric. Brushes should only be used for carpets and floor mats, since other fabric surfaces could be harmed by brushes.

Normal surface stains can be cleaned using a commercially available foam cleaner. Spread the foam on the surface of the fabric with a soft sponge and work it in gently. Do not saturate the fabric. Then pat the foam dry using absorbent, dry cloths (e.g. microfiber cloth) and vacuum it after it has dried completely.

#### Cleaning stains

Stains caused by beverages (e.g. coffee, fruit juice, etc.) can be treated with a mild detergent solution. Apply the detergent solution with a sponge. In the case of stubborn stains, a detergent paste can be applied directly to the stain and worked into the fabric. Afterwards, use copious amounts of clean water to remove the remaining detergent. Apply the water with a damp cloth or sponge and pat the fabric dry with an absorbent, dry cloth.

Stains from chocolate or makeup should have detergent paste (e.g. ox-gall soap) rubbed into them. Afterwards, remove the soap with water (damp sponge).

Alcohol can be used to treat stains from grease, oil, lipstick or a ballpoint pen. Melted grease or dye must be patted off using absorbent material. It may be necessary to re-treat the areas with detergent paste and water.

In the case of general soiling of the upholstery and cover material, we recommend hiring a specialist that has the equipment to clean the seat covers and other fabric surfaces by shampooing and spray extraction.

### **WARNING**

Always read and heed all WARNINGS and the information ⇒ *page 245*.

### **Tips**

Open Velcro fasteners on your clothing can damage the seat cover. Please make sure that Velcro fasteners are closed.

## **Plastic parts and instrument panel**

Always use a clean cloth moistened in clear water to clean these areas. For persistent dirt use an Audi approved **solvent-free** plastic cleaner/protectant.

### **WARNING**

Solvents can change the properties of some plastics and make it harder for the airbag to deploy.

- Never clean the instrument panel or the surface of airbag modules with cleaning products that contain solvents.
- Products containing solvents will make the surface of this part porous.
- Serious injuries can result if plastic parts come loose when the airbag is deployed.
- Always read and heed all WARNINGS and other information ⇒ *page 245*.

### **Note**

Cleaning agents containing solvents will attack the material and can change the way it behaves.

## **Natural leather**

Applies to vehicles: with natural leather

*Audi makes great efforts to maintain the properties, natural look and feel of interior leather.*

### **General**

We offer many different types of leather on our vehicles. Most are different types of nappa leather, which has a smooth surface and comes in various colors.

The intensity of the color determines the visual characteristics and appearance. If the surface of the leather has a typical natural look, then the leather is a nappa leather that has been left in a relatively natural condition. This leather offers particularly good comfort and breathes well. Fine veins, closed grains, insect bites, skin folds, and subtle variations in color remain visible. These characteristics demonstrate that the material is natural.

Natural nappa leather is not covered by a color finish. It is therefore more sensitive to soiling and wear, which is something you need to consider if children, animals or other factors might prove to be particularly hard on the leather.

By contrast, leather types that are covered by a colored finish layer are more durable. This has a positive effect on the leather's resistance to wear and soiling in daily use. On the other hand, the typical characteristics of natural leather are barely or not apparent. However, this does not mean that the leather itself is of inferior quality.

### **Care and handling**

Because of the exclusive nature of the types of leather that Audi uses and their unique properties (such as sensitivity to oils, grease, soiling, etc.), you will need to be somewhat careful with these leathers, and a certain type of care is required. For example, dark clothing materials can discolor leather seats (especially if such clothing is damp and was not dyed correctly). Dust and dirt particles in pores, folds, and seams can have an abrasive effect ►

and can damage the leather surface as well as weaken seams.

The leather should be cleaned regularly as needed. After having been used for a relatively long time, your leather seats will acquire a rich aged finish. This is a characteristic of natural leather and a sign of true quality.

In order to maintain the value of this natural product over the life of your vehicle, you should follow the recommendations below:

### Note

- To keep your leather from bleaching out, do not allow it to be exposed to bright sunlight for long periods of time. If you have to leave the vehicle parked outside for long periods, cover the leather to protect it from direct exposure to sunlight.
- Sharp objects on clothing, such as zippers, rivets or sharp pieces on belts can leave permanent scratches or scrape marks on the surface of the leather.

### Tips

- After each time you clean the leather and at regular intervals, use a leather preservative creme that contains UV-blockers and that works into the leather. This creme will nourish and moisturize the leather, helping it to breathe and stay supple. It also helps to build up a protective coating on the surface.
- Clean the leather every 2 - 3 months, and clean any areas that get soiled.
- Remove fresh marks made by ballpoint pens, ink, lipstick, shoe polish, etc. as soon as possible.
- Preserve the color of the leather as needed by using a special colored leather care creme to touch up areas of uneven color.

## Cleaning and caring for leather upholstery and trim

Applies to vehicles: with natural leather

*Natural leather requires special care and attention.*

### Normal cleaning

- ▶ Clean soiled areas with a slightly moistened cotton or woolen cloth.

### More stubborn dirt

- ▶ More stubborn dirt can be removed using a cloth saturated with a mild soap solution (2 tablespoons mild liquid soap).
- ▶ Never allow the soap solution to saturate the leather, and make certain that no water soaks into the seams.
- ▶ Wipe off the soap solution with a soft, dry cloth.

### Cleaning spots

- ▶ Remove fresh **water-based** spots (such as coffee, tea, juices, blood) with an absorbent cloth or paper towel.
- ▶ Remove fresh **grease or oil-based spots** (such as butter, mayonnaise, chocolate) with an absorbent cloth or paper towel, or use the cleaner from the leather care kit if the spot has not yet penetrated into the surface of the leather.
- ▶ Use an oil/grease dissolving spray, if **oil/grease spots have dried on**.
- ▶ Remove specific kinds of spots (ballpoint pen, felt marker, fingernail polish, water-based paint, shoe polish, etc.) with a spot remover specifically formulated for leather.

### Leather care

- ▶ Every half year use an approved leather care product (available from your authorized Audi dealer) to care for the leather.
- ▶ Apply the product very sparingly.
- ▶ Wipe it off with a damp cloth.

If you have any questions about cleaning and caring for the leather in your vehicle, it is best to contact your authorized Audi dealer, who will be glad to help you and tell you about our full range of leather care products, such as: ▶

- Leather cleaning and care kit
- Creams to care for colored leather
- Spot removers for ballpoint pens, shoe polish, etc.
- Oil/grease dissolving spray
- New and upcoming products.

 **WARNING**

Always read and heed all WARNINGS and other information ⇒ *page 245*.

 **Note**

- Never use chemical solvents (e.g. lighter fluid, turpentine), waxes, shoe polish or similar products on the leather surfaces in your Audi.
- To avoid damage, have stubborn stains removed by a commercial cleaning specialist.

**Cleaning Alcantara® (synthetic suede)**

Applies to vehicles: with Alcantara upholstery

**Removing dust and dirt**

- ▶ Moisten a cloth, *squeeze out excess water* and wipe down the seat surfaces.

**Removing stains**

- ▶ Moisten a cloth with lukewarm water or with diluted **ethyl (rubbing) alcohol**.
- ▶ Dab at the stain. Start at the outside and work inwards.
- ▶ Once the stain is no longer visible, use a soft dry cloth or tissue to soak up the moisture.

Do not use leather cleaning products on Alcantara.

You may use a suitable shampoo for removing dust and dirt.

Dust and grit in the pores and seams can scratch and damage the surface. If the car is left standing in the sun for long periods, the Alcantara should be protected against direct sunlight to prevent it from fading. Slight color variations will develop in normal use and are not an indication of material deterioration.

 **Note**

- Never use chemical solvents (e.g. lighter fluid, turpentine), waxes, shoe polish or similar products on Alcantara® surfaces.
- To avoid damage, have stubborn stains removed by a commercial cleaning specialist.
- Do not use brushes, stiff sponges or similarly abrasive cleaning aids.

**Safety belts**

*Only well-maintained safety belts work reliably when needed.*

- ▶ Keep belts clean.
- ▶ For cleaning, use a mild soap and water solution. Let belts dry thoroughly and away from direct sunlight.
- ▶ Do not allow inertia reel safety belts to retract before they are completely dry.
- ▶ Check the condition of your safety belts *regularly*.

Heavily soiled safety belts may not retract properly.

 **WARNING**

- Damaged safety belts can break in a crash.
- Anything that might damage your safety belts could mean that you and your passengers would not be adequately protected in an accident.
  - Safety belt performance depends on correct installation. Never remove belts from the vehicle to clean them.
  - Do not use chemical cleaning agents, bleach or dyes. They have corrosive properties which weaken the webbing.
  - When cleaning your safety belts, inspect them for damage. If you discover damage, see your authorized Audi dealer.
  - Always read and heed all WARNINGS and other information ⇒ *page 245*.

## Engine compartment

Be especially careful when cleaning the engine compartment.

**Always switch off the ignition before cleaning the engine** ⇨ ⚠.

### Plenum panel

Remove leaves from the plenum panel in front of the windshield under the engine hood. This prevents the water drain holes from becoming blocked, and it prevents debris from entering the vehicle interior through the heating and ventilation ducts.

### Corrosion protection

The engine compartment and transmission have been corrosion-protected at the factory.

Good anti-corrosion treatment is very important, particularly in the winter. If the vehicle is frequently driven on salt treated roads, the entire engine compartment and plenum panel should be thoroughly cleaned at the end of winter and retreated to prevent salt damage. At the same time, the underside of the vehicle should be washed as well.

If the engine compartment is cleaned at any time with grease removing solutions<sup>1)</sup>, or if you have the engine washed, the anti-corrosion treatment is almost always removed as well. It is therefore essential to have a long-lasting corrosion protection reapplied to all surfaces, seams, joints and components in the engine compartment.

### WARNING

Be aware: The engine compartment of any motor vehicle is a potentially hazardous area.

- Before working in the engine compartment, be sure to read the information ⇨ *page 264*.
- Before reaching into the front plenum panel, always remove the ignition key.

Otherwise, the windshield wiper system could unintentionally be switched on, possibly causing personal injury from the moving wiper linkage.

- Never reach into the area around or touch the radiator fan. The auxiliary fan is temperature controlled and can switch on suddenly - even when the ignition is off.
- Do not wash, wax or dry the engine with the engine running. Moving or hot parts could injure you.
- Do not clean the underside of the chassis, fenders, wheel covers, or other hard to reach parts without protecting your hands and arms. You may cut yourself on sharp-edged metal parts.
- Always read and heed all WARNINGS and other information ⇨ *page 245*.

<sup>1)</sup> Use only the correct cleaning solutions. Never use gasoline or diesel fuel.

## Fuel supply and filling your fuel tank

### Fuel supply

#### Gasoline

Applies to vehicles: with gasoline engine

*Using the right fuel helps keep the environment clean and prevents engine damage.*

#### Fuel recommendation

The fuel recommended for your vehicle is **unleaded premium** grade gasoline. See also ⇒ *page 322, Data*. Audi recommends using TOP TIER Detergent Gasoline with a minimum octane rating of 91 AKI (95 RON). For more information on TOP TIER Detergent Gasoline, please go to the official website ([www.toptier-gas.com](http://www.toptier-gas.com)).

The recommended gasoline octane rating for your engine can also be found on a label located on the inside of the fuel filler flap. This rating may be specified as AKI or RON.

Your vehicle may also be operated using unleaded regular gasoline with a minimum octane rating of 87 AKI/91 RON. However, using 87 AKI/91 RON octane fuel will slightly reduce engine performance.

**Use unleaded gasoline only.** Unleaded gasoline is available throughout the USA, Canada, and in most European countries. We recommend that you do not take your vehicle to areas or countries where unleaded gasoline may not be available.

For more information on refueling your vehicle, see ⇒ *page 258*.

#### Octane rating

Octane rating indicates a gasoline's ability to resist engine damaging "knock" caused by premature ignition and detonation. Therefore, buying the correct grade of gasoline is very important to help prevent possible engine damage and a loss of engine performance.

Gasoline most commonly used in the United States and Canada has the following octane

ratings that can usually be found on the filler pump:

- Premium Grade: 91 - 96 AKI
- Regular Grade: 87 - 90 AKI

Explanation of the abbreviations:

AKI = **A**nti **K**nock **I**ndex =  $(R+M)/2 = (RON + MON)/2$

RON = **R**esearch **O**ctane **N**umber

MON = **M**otor **O**ctane **N**umber.



#### Note

- Do not use any fuel with octane ratings lower than 87 AKI or 91 RON otherwise expensive engine damage will occur.
- Do **not** use leaded gasoline. The use of leaded gasoline will severely damage your vehicle's catalytic converter and its ability to control exhaust emissions.

#### Blended gasoline

Applies to vehicles: with gasoline engine

#### Use of gasoline containing alcohol or MTBE (methyl tertiary butyl ether)

You may use unleaded gasoline blended with alcohol or MTBE (commonly referred to as oxygenates) if the blended mixture meets the following criteria:

#### Blend of gasoline methanol (wood alcohol or methyl alcohol)

- Anti-knock index must be 87 AKI or higher.
- Blend must contain no more than 3% methanol.
- Blend must contain more than 2% co-solvents.

#### Blend of gasoline and ethanol (grain alcohol or ethyl alcohol)

- Anti-knock index must be 87 AKI or higher.
- Blend must not contain more than 10% ethanol.

#### Blend of gasoline and MTBE

- Anti-knock index must be 87 AKI or higher. ►

- Blend must contain not more than 15% MTBE.

### Seasonally adjusted gasoline

Many gasoline grades are blended to perform especially well for winter or summer driving. During seasonal change-over, we suggest that you fill up at busy gas stations where the seasonal adjustment is more likely to be made in time.

#### Note

- Methanol fuels which do not meet these requirements may cause corrosion and damage to plastic and rubber components in the fuel system.
- Do not use fuels that fail to meet the specified criteria in this chapter.
- If you are unable to determine whether or not a particular fuel blend meets the specifications, ask your service station or its fuel supplier.
- Do not use fuel for which the contents cannot be identified.
- Fuel system damage and performance problems resulting from the use of fuels different from those specified are not the responsibility of Audi and are not covered under the New Vehicle or the Emission Control System Warranties.
- If you experience a loss of fuel economy or driveability and performance problems due to the use of one of these fuel blends, we recommend that you switch to unblended fuel.

### Gasoline additives

Applies to vehicles: with gasoline engine

A major concern among many auto manufacturers is carbon deposit build-up caused by the type of gasoline you use.

Although gasoline grades differ from one manufacturer to another, they have certain things in common. All gasoline grades contain substances that can cause deposits to collect on vital engine parts, such as fuel injectors and intake valves. Although most gasoline

brands include additives to keep engine and fuel systems clean, they are not equally effective.

Audi recommends using TOP TIER Detergent Gasoline. For more information on TOP TIER Detergent Gasoline, please go to the official website ([www.toptiergas.com](http://www.toptiergas.com)).

After an extended period of using inadequate fuels, carbon deposit build-ups can rob your engine of peak performance.

#### Note

Damage or malfunction due to poor fuel quality is not covered by the Audi New Vehicle Limited Warranty.

## Diesel fuel

Applies to vehicles: with diesel engine

*Always use ULSD (Ultra Low Sulfur Diesel) sulfur content 15 ppm or less.*

The ULSD (Ultra Low Sulfur Diesel) meets the ASTM-D-975 (grade 2).

**Diesel fuel with a higher concentration than ULSD-Diesel No. 2 ASTM D975 and Bio-diesel with a higher concentration than 5 % like B11, B20 or B100 are strictly prohibited.**

Service station fuel pumps are labeled with the correct fuel information for easy recognition by the user. If the diesel fuel pump is not labeled ask the station operator what fuel is being dispensed before filling up your vehicle.

Service stations offering Diesel fuel are generally located on truck routes or major highways. Directories of Diesel fuel stations are usually available at Diesel fuel stations.

Some states in the USA require permits to purchase Diesel fuel. Check with your State Motor Vehicle Department.

Diesel fuel may not be available outside the USA and Canada. Be sure to check before traveling to other countries. ▶

## Winter operation

At temperatures below 20° F (-7° C), Diesel fuel No. 2 loses its fluidity due to wax separation, which may clog the fuel filter or tank filter and keep the engine from running.

To help the filter from being clogged by wax, the fuel filter in your vehicle is automatically preheated. Preheating the fuel filter makes operation of your vehicle possible with Diesel fuel No. 2 down to -10° F (-24° C).

If you expect temperatures below 5° F (-15° C) ask your fuel dealer whether their Diesel fuel No. 2 is sufficiently winterized for the prevailing and expected temperatures.

If not winterized or insufficiently winterized Diesel fuel has already thickened to the extent that the engine will not start, warm the vehicle up by leaving it in a heated garage.

It is normal that the engine noise level (dieseling) is louder during the warm-up period in winter. It is also normal when whitish-blue smoke comes out of the tailpipe after starting and during warm-up. The amount of smoke depends on the outside temperature.

Do not let your Diesel engine idle unnecessarily after a cold start. Driving off slowly will shorten the warm-up period.

### WARNING

- Never use “starting assist fluids.” They may be potentially explosive or cause a “run-away” engine condition. This could result in serious engine damage and personal injury.
- Never use fuel line anti-freeze offered for gasoline engines.

### Note

- Your Diesel engine has been specifically designed to operate only on Ultra Low Sulfur Diesel fuel. Therefore, never use home heating oil or regular gasoline. The properties of these fuels may cause serious damage to the fuel injection system and to the engine. Using these fuels can

cause expensive engine repairs and will also adversely affect your New Vehicle Limited Warranty.

- If Diesel fuel should get on any rubber hose, it must be wiped off immediately. Then wash the contaminated hose portion with soap and warm water. Do not allow Diesel fuel to remain on connecting hoses. They may develop leaks and cause serious damage.

## Fuel tank

### Fuel filler neck

The fuel filler neck is located on the right rear side panel behind the fuel filler flap.

If the power locking system should fail, you can still open the flap manually - for detailed instructions see ⇒ *page 261*.

You can find the fuel tank capacity of your vehicle in **Technical Data** ⇒ *page 322*.

The label on the inside of the fuel filler flap tells you the correct fuel for your vehicle. For more information about fuel specifications, see ⇒ *page 256*.

Your vehicle fuel tank has an on-board refueling vapor recovery system. This feature helps to prevent fuel vapors from escaping from the tank and polluting the environment while you refuel your vehicle. In order to fill the tank properly while protecting the environment, please follow this refueling procedure carefully.

### WARNING

Under normal operating conditions, never carry additional fuel containers in your car. Gas canisters and other containers used to transport fuel can be dangerous. Such containers, full or empty, may leak and could cause a fire in a collision. If you must transport fuel to use for your lawn mower, snow blower, etc., be very careful and always observe local and state laws regarding the use, transportation and storage of such fuel containers. Make certain the

container meets industry standards (ANSI/ASTM F852 - 86).

### **!** Note

Never drive your vehicle until the fuel tank is completely empty. The irregular supply of fuel can cause misfiring. Gasoline could enter the exhaust system and damage the catalytic converter.

## Refuelling

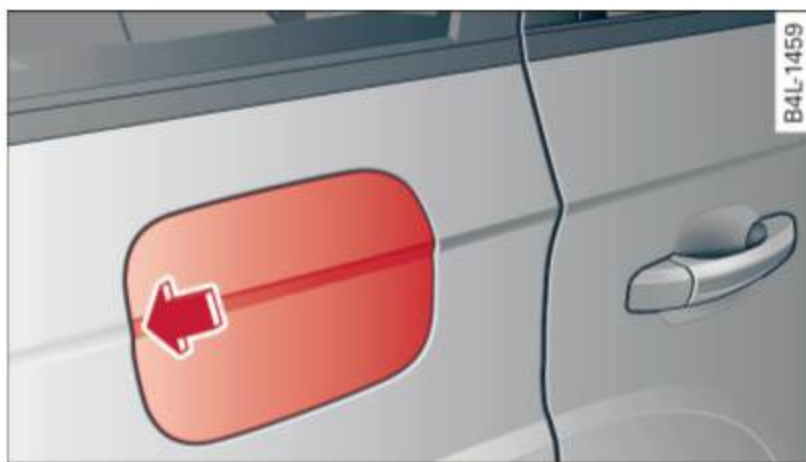

**Fig. 234** Right rear vehicle side: Opening the fuel filler flap



**Fig. 235** Fuel cap hooked on the opened fuel filler flap

When adding fuel, the ignition and any cellular phones in the vehicle must be switched *off*. When activating the central locking, the fuel filler flap is automatically unlocked or locked. Refuel the vehicle with the ignition turned *off*.

### Taking the fuel cap off

- ▶ To open the fuel filler flap, press on the left side of the flap ⇒ *fig. 234 -arrow-*.
- ▶ Unscrew fuel filler cap counter-clockwise and hang it on the fuel filler flap ⇒ *fig. 235*.
- ▶ Check the label on the inside of the fuel filler flap to determine if the vehicle must be fueled with gasoline or diesel fuel.

### Refuelling procedure

- ▶ Insert the fuel nozzle from the gasoline pump into the fuel filler neck as far as it will go.
- ▶ Select a medium refuelling rate so that the nozzle switches off automatically when the tank is full.

### Putting the fuel cap back on

- ▶ After filling your tank, twist the fuel filler cap clockwise as far as it will go.
- ▶ Close the fuel filler flap.

To avoid fuel spilling or evaporating from the fuel tank always close fuel filler cap properly and completely. An improperly closed fuel filler cap may also cause the MIL lamp ⇒ *page 27* to come on (only vehicles with gasoline engine).

### **!** WARNING

Improper refueling or handling of fuel can cause fire, explosion and severe burns.

- Fuel is highly flammable and can cause severe burns and other injuries.
- Failure to shut the engine off while refueling and/or to insert the pump nozzle fully into the fuel filler neck could cause fuel to spray out of filler neck or to overflow. Fuel spray and overflowing fuel can cause a fire.
- Never use a cellular telephone while refueling. The electromagnetic radiation can cause sparks that can ignite fuel vapors and cause a fire.
- Never get back into your vehicle while refueling. If in exceptional circumstances you must get back in your vehicle while refueling, make certain that you close the door and touch metal to discharge static electricity before touching the filler nozzle again. Static electricity can cause sparks that can ignite fuel vapors released during refueling.
- Never smoke or have an open flame anywhere in or near your vehicle when refueling or filling a portable fuel container.

- For your safety, we strongly recommend that you do not travel with a portable fuel container in your vehicle. The container, full or empty may leak and could cause a fire, especially in a crash.
- If, under exceptional circumstances, you must transport a portable fuel container, please observe the following:
  - Never fill a portable fuel container while it is anywhere in or on the vehicle (for example, in the luggage compartment, or on the trunk). Static electricity can build up while filling and can ignite fuel vapors causing a fire.
  - Always place a portable fuel container on the ground before filling.
  - Always keep the filler nozzle completely inside the portable container before and during filling.
  - If filling a portable container made of metal, the filler nozzle must always be in contact with the container. This will help prevent static electricity from discharging and cause a fire.
  - Never spill fuel inside the vehicle or luggage compartment. Fuel vapors are highly flammable.
  - Always observe local and state/provincial laws regarding the use, storage and transportation of fuel containers.
  - Make certain the fuel container meets industry standards (ANSI / ASTM F852-86).

### Note

If any fuel has spilled onto the car, it should be removed immediately to prevent damage to the paint.

### For the sake of the environment

As soon as the correctly operated nozzle switches off automatically for the first time, the tank is full. Do not try to add more fuel because fuel may spill out. In addition, the expansion space in the fuel tank will be filled - causing the fuel to

overflow when it becomes warm and pollute the environment.

### Tips

- Running your engine while refuelling may cause vapors to escape or even cause fuel to spill out of the tank. This would then shut off the fuel nozzle before the tank is full.
- Do not refuel your vehicle with the ignition turned on. The fuel gauge may otherwise not indicate the correct fuel level after refuelling.
- Diesel vehicles\* are equipped with a diesel misfueling protector. It allows the vehicle to be fueled only with a diesel fuel pump nozzle. A worn or damaged nozzle or a nozzle that is too small may not be able to open the diesel misfueling protector. If this is the case, try turning the nozzle before inserting it in the fuel filler neck, use a different fuel pump or see your authorized Audi dealer or authorized repair facility for assistance.

### Unlocking the fuel filler flap by hand

You can open the fuel filler flap by hand if the power locking system should fail.



Fig. 236 Luggage compartment: Prying cover open

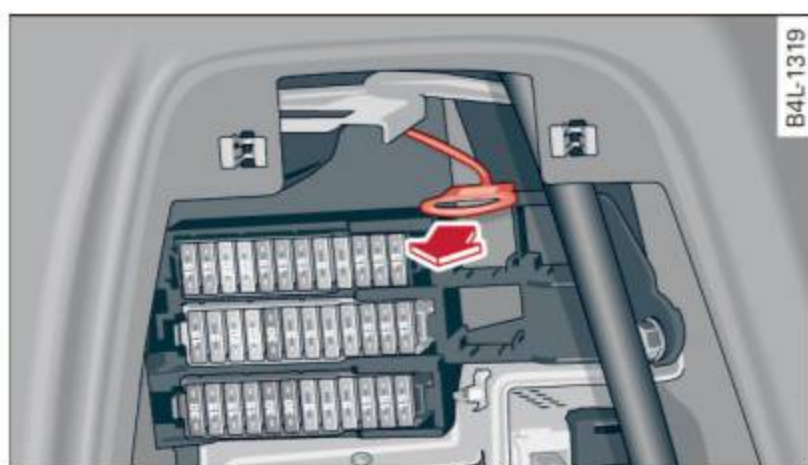

Fig. 237 Luggage compartment: Emergency opening of fuel filler flap

- ▶ Remove the right-side trim panel with the aid of a screwdriver ⇒ *fig. 236*.
- ▶ Pull the loop down in the direction of the arrow to unlock the fuel filler flap ⇒ *fig. 237*.

## Selective catalytic reduction

### General information

Applies to vehicles: with diesel engine

On vehicles with selective catalytic reduction, an urea solution (AdBlue®) is injected into the exhaust system before a nitrogen oxide catalytic converter to reduce nitrogen emissions.

The AdBlue is stored in a separate tank in the vehicle. The AdBlue usage accounts for approximately 0.5% to 1.2% of the diesel fuel that is used. The AdBlue tank capacity is approximately 6 gallons (23 liters).

You must refill the AdBlue or have it refilled by your authorized Audi dealer or qualified workshop as soon as the AdBlue refill mes-

sage appears in the instrument cluster ⇒ *page 262*.

### ! WARNING

Failure to heed AdBlue refill information in the instrument cluster can prevent the vehicle from being started and driven. If the vehicle cannot be driven and an emergency arises, personal injury can occur.

- Always have the AdBlue tank refilled well before the tank runs dry.

### i Tips

- The instrument cluster display indicates the distance remaining that can be driven ⇒ *page 261*. If the AdBlue tank is completely empty, the engine will not start again after the ignition is switched off.
- AdBlue is required by law to operate this vehicle.
- AdBlue® is a registered trademark of the Registered Automobile Association (Verband der Automobilindustrie e. V. - VDA).

### Indicator in the instrument cluster display

Applies to vehicles: with diesel engine

The display indicates if the AdBlue level is low or if it was filled incorrectly.

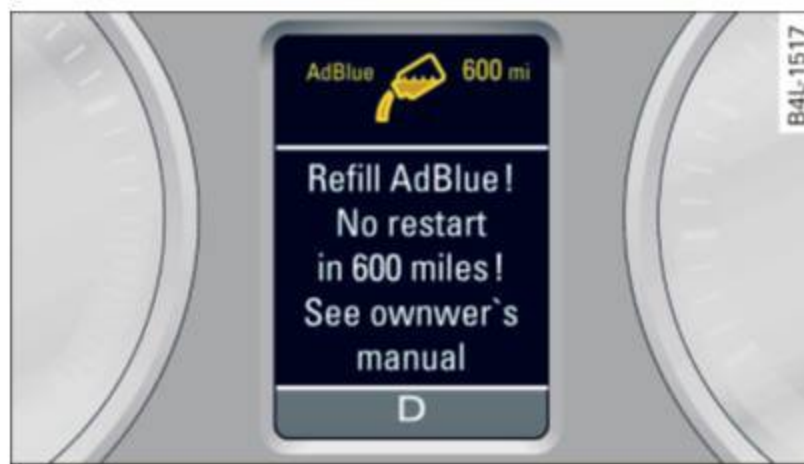

Fig. 238 Instrument cluster: indicator in the display

### AdBlue level low

You will be informed if the AdBlue in the tank drops below a certain level.

**AdBlue 1500 mi (2400 km) Refill AdBlue. See owner's manual**

This indicator appears when there is only enough AdBlue left to drive the distance indicated in the driver information system. Please add AdBlue.

**AdBlue 600 mi (1000 km) Refill AdBlue! No restart in 600 miles (1000 km)! See owner's manual**

This indicator appears when there is only enough AdBlue left to drive the distance indicated in the driver information system. Please add AdBlue. Otherwise the engine will not start again if you stop it once the distance indicated has been driven.

**AdBlue 0 mi (0 km) Refill AdBlue! No restart! See owner's manual**

This message appears when the AdBlue tank is empty. Please add AdBlue. Otherwise you will not be able to start the engine again once you stop it.

When the minimum AdBlue level has been reached, you must add AdBlue ⇒ *page 262*.

### Filling incorrectly

If the AdBlue tank was filled with a different fluid than AdBlue and the system detects that it is incorrect, a message will appear.

**AdBlue 600 mi (1000 km) AdBlue! No restart in 600 miles (1000 km)! See owner's manual**

This message appears when it is only possible to drive the distance indicated in the driver information system. Drive to the nearest qualified workshop to have the malfunction repaired. Otherwise the engine will not start again if you stop it once the distance indicated has been driven.

**AdBlue 0 mi (0 km) AdBlue: system fault. No restart! See owner's manual**

This message appears if the system detects it was filled incorrectly. Drive immediately to the nearest qualified workshop to have the malfunction repaired. Otherwise you will not be able to start the engine again once you stop it.

### Filling AdBlue

Applies to vehicles: with diesel engine

*A special refill bottle must be used to fill the AdBlue.*



Fig. 239 Right rear vehicle side: removing the AdBlue cap

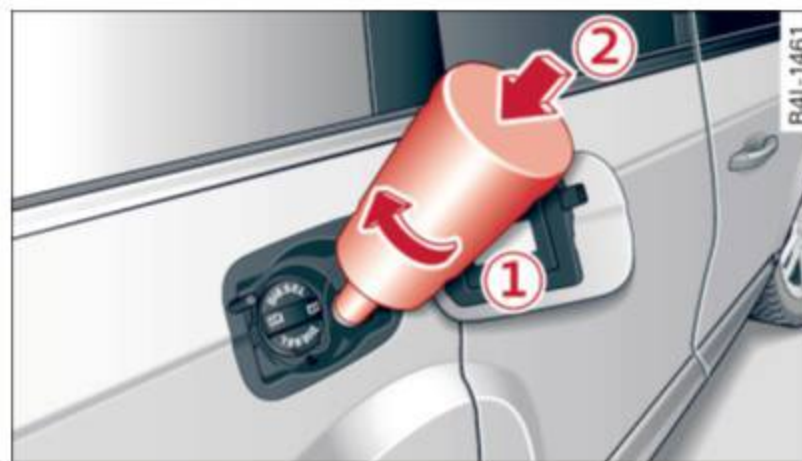

Fig. 240 AdBlue filler tube: inserting the refill bottle

The AdBlue filler tube is located near the diesel filler tube. Always add 1 gallon (3.8 liters) of AdBlue (two bottles). This is the minimum amount required to ensure the system detects the refilling and to start the engine.

### Opening the filler tube and adding AdBlue

Requirement: The request to add AdBlue must appear in the instrument cluster display.

- ▶ Switch the ignition off.
- ▶ Open the tank cover ⇒ *page 259*.
- ▶ Turn the cap counterclockwise with the lug wrench from the vehicle tool kit to remove it ⇒ *fig. 239*.
- ▶ Remove the cap from the refill bottle.
- ▶ Position the refill bottle on the filler tube and turn the bottle clockwise until it stops turning ① ⇒ *fig. 240*.
- ▶ Press lightly against the bottom of the bottle ② to empty it. Continue pressing the

bottom of the bottle until it is empty or until fluid stops flowing into the tank.

- ▶ Turn the bottle to the left without pressing on the bottom.

### Closing the filler tube

- ▶ Turn the cap clockwise on the filler tube with the lug wrench until you hear it tighten completely.
- ▶ Close the tank cover.

### After filling

The vehicle must be driven. The system may take up to two minutes to detect that the AdBlue has been filled.

- ▶ If there was no AdBlue left in the tank and a range of **0 mi (0 km)** was displayed in the instrument cluster, switch the ignition on for about 15 seconds before starting the engine.

### WARNING

AdBlue can irritate the skin, eyes and respiratory system. If there is contact with the fluid, flush immediately with plenty of water. Consult a physician if necessary.

### Note

- Only use AdBlue that conforms to the standard ISO 22241-1. Do not mix any additives with the AdBlue and do not dilute it with water.
- AdBlue is not a diesel additive. Do not add it to the diesel tank. If AdBlue is mixed with diesel fuel, it can lead to damage to the engine and the AdBlue tank system. The Limited New Vehicle Warranty does not cover such damage.
- AdBlue attacks surfaces such as painted vehicle components, plastic and carpet. Remove the fluid as quickly as possible with a damp cloth and plenty of cold water. If the AdBlue has already crystallized, use warm water and a sponge. AdBlue residue that is not removed will crystallize and can damage the affected surface.

- Do not store the refill bottle in the vehicle. If it leaks, the escaping AdBlue could damage the vehicle interior.
- Do not allow AdBlue to come into contact with clothing. If there is contact with the fluid, flush immediately with plenty of water.

### Tips

- You can obtain refill bottles from any authorized Audi dealer or other qualified workshop.
- Follow the AdBlue manufacturer's instructions for usage and storage.

## Checking and filling

### Engine hood

#### Releasing the engine hood

The engine hood is released from inside the vehicle.

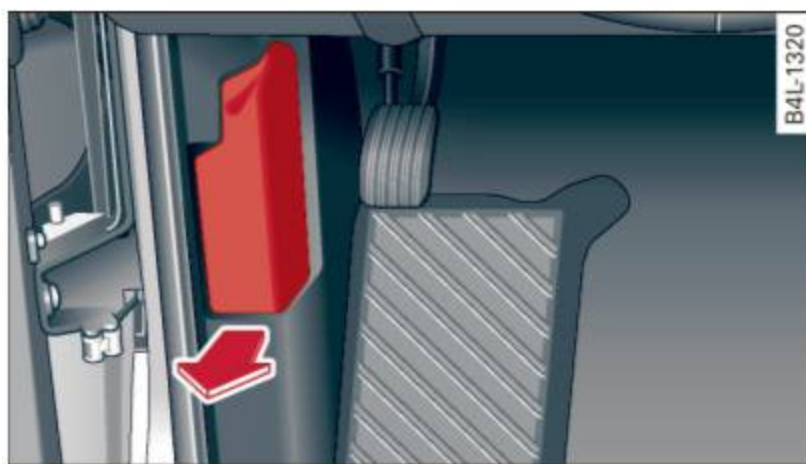

Fig. 241 Driver's side footwell: engine hood release lever

- ▶ Open the driver's door.
- ▶ Pull the release lever on the left under the instrument panel ⇒ *fig. 241* in the direction of the arrow.

The hood pops up slightly under spring pressure.

#### Opening the engine hood



Fig. 242 Release lever under the engine hood

Before opening the engine hood, make sure that the windshield wipers are flat against the windshield. Otherwise, they could damage the paint on the hood.

- ▶ Lift the hood slightly ⇒ ⚠.
- ▶ Pull up on the release under the hood ⇒ *fig. 242*. This releases the catch.
- ▶ Open the hood all the way.

#### ⚠ WARNING

Hot engine coolant can burn you.

- To reduce the risk of being burned, never open the hood if you see or hear steam or coolant escaping from the engine compartment. Wait until no steam or coolant can be seen or heard before carefully opening the hood.

#### Closing the engine hood

- ▶ Pull the hood down until the pressure from the struts is reduced.
- ▶ Let the hood *drop down* and latch in place. *Do not try to push it shut*; it may fail to engage ⇒ ⚠.

#### ⚠ WARNING

A hood that is not completely latched could fly up and block your view while driving.

- When you close the engine hood, check it to make sure the safety catch has properly engaged. The hood should be flush with the surrounding vehicle body parts.
- If you notice while driving that the hood is not secured properly, stop at once and close it.

#### Working in the engine compartment

Be especially careful whenever you work in the engine compartment.

Whenever you must perform any work in the engine compartment, for example checking and filling different fluids, there is a risk of injury, burns and accidents. To prevent personal injury always observe the following **WARNINGS**. The engine compartment of any vehicle is a hazardous area ⇒ ⚠.

#### ⚠ WARNING

To help avoid injury, before you check anything under the hood:

- Turn off the engine.
- Remove the ignition key.

- Apply the parking brake.
- Move selector lever to “P” (Park).
- Always let the engine cool down. Hot components will burn skin on contact.
- To reduce the risk of being burned, never open the hood if you see or hear steam or coolant escaping from the engine compartment. Wait until no steam or coolant can be seen or heard before carefully opening the hood.
- Keep children away from the engine compartment.
- Never spill fluids on hot engine components. They can cause a fire.
- Never touch the radiator fan. The auxiliary electric fan is temperature controlled and can switch on suddenly.
- Never open the coolant reservoir cap when the engine is still warm. The coolant system is pressurized and hot coolant could spray out.
- Protect your face, hands and arm from steam or hot engine coolant by placing a thick rag over the cap when you open the coolant reservoir.
- Do not remove the engine cover under any circumstances. This increases the risk of burns.
- If work on the fuel system or the electrical system is necessary:
  - Always disconnect the battery.
  - Never smoke or work near heaters or open flames. Fluids in the engine compartment could start a fire.
  - Keep an approved fire extinguisher immediately available.
- To avoid electrical shock and personal injury while the engine is running or being started, never touch:
  - Ignition cables
  - Other components of the high voltage electronic ignition system.
- If you must perform a check or repair with the engine running:

- First, fully apply the parking brake, move selector lever to “P” (Park).
- Always use extreme caution to prevent clothing, jewelry, or long hair from getting caught in the radiator fan, V-belts or other moving parts, or from contacting hot parts. Tie back hair before starting, and do not wear clothing that will hang or droop into the engine.
- Minimize exposure to emission and chemical hazards ⇒ .

### **WARNING**

California Proposition 65 Warning:

- Engine exhaust, some of its constituents, and certain vehicle components contain or emit chemicals known to the State of California to cause cancer and birth defects and reproductive harm. In addition, certain fluids contained in vehicles and certain products of component wear contain or emit chemicals known to the State of California to cause cancer and birth defects or other reproductive harm.
- Battery posts, terminals and related accessories contain lead and lead compounds, chemicals known to the State of California to cause cancer and reproductive harms. Wash hands after handling.

### **Note**

When adding fluids, always make sure that they are poured into the proper container or filler opening, otherwise serious damage to vehicle systems will occur.

### **For the sake of the environment**

To detect leaks in time, inspect the vehicle floor pan from underneath regularly. If you see spots from oil or other vehicle fluids, have your vehicle inspected by an authorized Audi dealer.

## Engine compartment

These are the most important items that you can check.

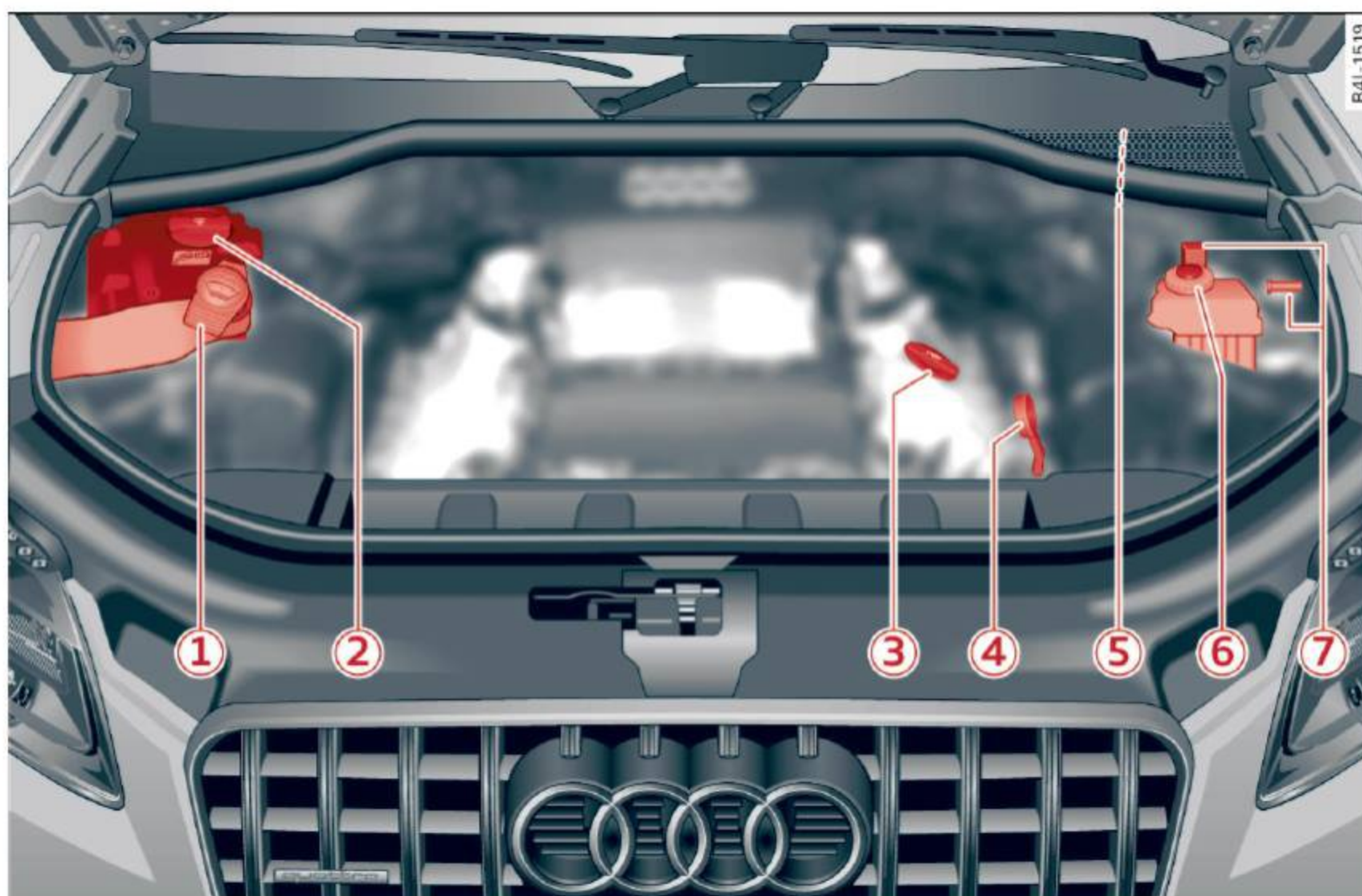

Fig. 243 Typical layout for containers, engine oil dipstick and engine oil filler cap

- |   |   |          |
|---|---|----------|
| ① | Windshield/headlight washer container (☞) . . . . .             | 279      |
| ② | Coolant expansion tank (☞) . . . . .                            | 272      |
| ③ | Engine oil filler cap (☞) . . . . .                             | 270      |
| ④ | Engine oil dipstick (orange) . . . . .                          | 269      |
| ⑤ | Brake fluid reservoir (☞) . . . . .                             | 274      |
| ⑥ | Power steering reservoir . . . . .                              | 230      |
| ⑦ | Jump start connector (+) under a cover, (-) with hex head screw | 277, 314 |

The position of the engine oil filling hole and the engine oil dipstick ⇒ *fig. 243* (position ③ and ④) can vary according to the type of engine.

### ⚠ WARNING

Before you check anything in the engine compartment, always read and heed all WARNINGS ⇒ ⚠ in *Working in the engine compartment* on page 264.

## Engine oil

### Engine oil specifications

*The engine oil used in your Audi needs the right kind of oil.*

The engine in your Audi is a sophisticated powerplant that was built to exacting specifications. This engine needs the right kind of engine oil that meets specifications regarding quality and viscosity so that it can run smoothly and reliably. Choosing the right oil and changing oil within the time and mileage intervals printed in your vehicle's Warranty & Maintenance booklet matters a lot more today than it did years ago. Audi has developed a special quality standard for engine oil that will help assure that your vehicle's engine will get the lubrication it needs for proper operation.

Modern engine lubrication has taken a quantum leap in the last few years. Many synthetic ▶

oils available today provide better engine lubrication that can outlast traditional petroleum-based oils, making them a smart choice for use throughout the life of your Audi.

Whether you use synthetic or petroleum-based engine oil, the oil that you use must conform to Audi's oil quality standard VW 502 00 (vehicles with gasoline engine) or VW 507 00 (vehicles with diesel engine) to help keep your vehicle's engine running smoothly and help prevent the formation of harmful deposits, sometimes called "sludge," that over time can lead to expensive repairs.

At the time of printing, engine oils available in the U.S. and Canada that meet the exacting specifications of Audi oil standard VW 502 00 (vehicles with gasoline engine) or VW 507 00 (vehicles with diesel engine) are synthetic engine oils. This does not mean, however, that every synthetic engine oil will meet Audi oil standard VW 502 00 (vehicles with gasoline engine) or VW 507 00 (vehicles with diesel engine). So always be sure that you use an approved oil.

To help prevent the formation of harmful deposits use only oil with the following specifications printed on the oil container:

- **Audi oil standard VW 502 00 (gasoline engine)**
- **Audi oil standard VW 507 00 (diesel engine)**

Oil container labels may carry the specification singly or in combination with other designations and oil quality standards.

### Viscosity

Engine oils are graded according to their viscosity. The proper viscosity grade oil for your engine depends on climactic or seasonal conditions where you drive. You can use oil with a viscosity grade of SAE 5W40 across all temperature ranges for normal driving conditions.

However, if engine oil viscosity grade SAE 5W40 is not available, you can also use viscosity grade SAE 5W-30 or SAE 0W-40 as long as it meets Audi oil quality standard VW 502 00

(vehicles with gasoline engine) or VW 507 00 (vehicles with diesel engine) specifications.

Because engine oil that meets the Audi oil standard may not be available everywhere when you need it, we strongly recommend that you always carry with you an extra quart (liter) of oil that expressly conforms to the VW 502 00 (vehicles with gasoline engine) or VW 507 00 (vehicles with diesel engine) specification, in case you have to top off the oil while on the road.

**Applies to vehicles with gasoline engine only:** Only if the level of the oil is at or below the minimum mark on the oil dipstick - and no oil that expressly conforms to Audi oil standard VW 502 00 specifications is available - may you top off with a high quality engine oil, preferably synthetic-based, that meets ACEA A3 or API SM specifications, but even then, only in viscosity grades SAE 5W-40, SAE 5W-30, or SAE 0W-40. However, during the entire time between oil change intervals, never top off with more than a total of 0.5 qt/liter engine oil that does not conform to Audi oil specification VW 502 00.

**Applies to vehicles with diesel engine only:** Only if the level of the oil is at or below the minimum mark on the oil dipstick - and no oil that expressly conforms to Audi oil standard VW 507 00 specifications is available - may you top off with a high quality engine oil, that meets ACEA C3 or API CF specifications, but even then, only in viscosity grades SAE 5W-40, SAE 5W-30, or SAE 0W-40. However, during the entire time between oil change intervals, never top off with more than a total of 0.5 qt/liter engine oil that does not conform to Audi oil specification VW 507 00.

For more information about engine oil that has been approved for your vehicle, please contact either your authorized Audi dealer or Audi Customer Relations at 1 (800) 822-2834 or visit our web site at [www.audiusa.com](http://www.audiusa.com) or [www.audicanada.ca](http://www.audicanada.ca). Here you will also find a current list of oils (manufacturers, brand names etc.) that conform to Audi oil standard ►

VW 502 00 (vehicles with gasoline engine) or VW 507 00 (vehicles with diesel engine).

### Changing the engine oil

The engine oil and oil filter must be changed according to the mileage (kilometers) and time intervals specified in your vehicle's Warranty & Maintenance booklet. Do not exceed these intervals – harmful deposits from old engine oil can reduce engine performance and can lead to expensive engine repairs.

Changing the oil at the recommended intervals is so very important because the lubricating properties of oil decrease gradually during normal vehicle use. If you are not sure when you have your oil changed, ask your authorized Audi Service Advisor.

Under some circumstances the engine oil should even be changed more frequently. Change oil more often if you drive mostly short distances, operate the vehicle in dusty areas or mostly under stop-and-go traffic conditions, or when you use your vehicle where temperatures stay below freezing point for long periods.

Detergent additives in the oil will make fresh oil look dark after the engine has been running for a short time. This is normal and is not a reason to change the oil more often than recommended.

### Damage or malfunctions due to lack of maintenance

It is essential that you change your oil at the recommended intervals using only engine oil that complies with Audi oil standard VW 502 00 (vehicles with gasoline engine) or VW 507 00 (vehicles with diesel engine). Your Limited New Vehicle Warranty does not cover damage or malfunctions due to failure to follow recommended maintenance and use requirements as set forth in the Audi Owner's Manual and Warranty & Maintenance booklet. Your dealer will have to deny warranty coverage unless you present to the dealer proof in the form of Service or Repair Orders that all

scheduled maintenance was performed in a timely manner.

### Engine oil consumption

To provide effective lubrication and cooling for internal engine parts, all internal combustion engines use some oil. Oil consumption varies from engine to engine and may change over the life of the engine. Engines tend to use more oil during the break-in period than they do afterward, when oil consumption has stabilized. Depending on the way the vehicle is driven and the operating conditions, oil consumption can be up to 1 quart per 1,200 miles (1 liter per 2,000 km). Consumption may be higher within the first 3,000 miles (5,000 km).

Under normal conditions, the rate of oil consumption depends on oil quality as well as viscosity, engine speed (rpm), outside temperature, road conditions, the amount of oil dilution caused by condensed water or fuel residue, and oxidation of the oil. Oil consumption may increase with engine wear over time, until replacement of worn engine parts may become necessary.

Because of all these variables, there is no standard or "normal" rate of oil consumption. **We urge you to check the engine oil level at regular intervals, preferably every time you fill the fuel tank, and always before a long trip.**

**The oil pressure warning light  is not an indicator of low engine oil level. If the warning light does not go out after starting, or flashes while driving (above 1500 rpm), a buzzer will sound. It indicates that the oil pressure is too low. Stop the engine immediately, check the engine oil level and add oil if necessary. If the engine oil level is normal, but the light continues to flash, do not keep driving or let the engine idle, as damage may occur.**

If you believe your engine uses too much oil, we recommend that you consult your authorized Audi dealer so that the cause of your concern can be properly diagnosed. Keep in mind that accurate measurement of oil consumption requires great care and may take some time. Your Audi dealer has instructions for how to measure oil consumption accurately.

**! WARNING**

Stop! Before working in the engine compartment, always read and heed all WARNINGS ⇒ **! in Working in the engine compartment on page 264.** The engine compartment of any motor vehicle is a potentially dangerous area and can cause serious personal injury.

**! Note**

- The engine depends on oil to lubricate and cool all of its moving parts. The engine oil must be checked regularly and kept at the required level.
- Make it a habit to have the engine oil level checked every time you fill the fuel tank.
- Too little engine oil may cause severe engine damage.

**Checking the engine oil level**

*The dipstick indicates the engine oil level.*

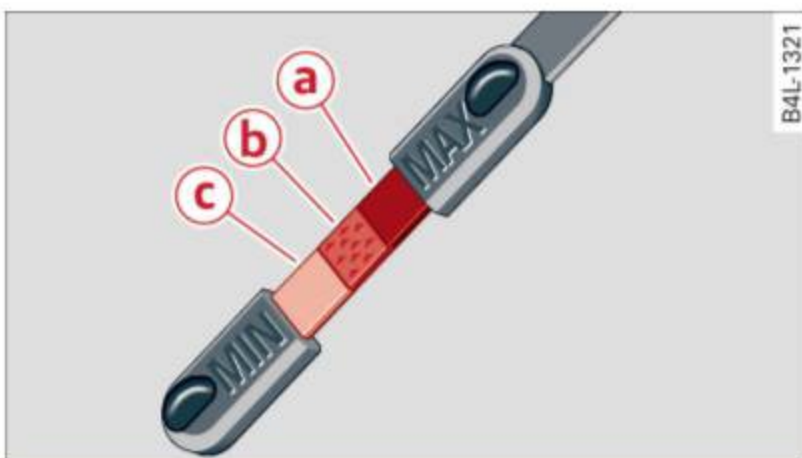

**Fig. 244** Illustration of principle 1: Markers on oil dipstick

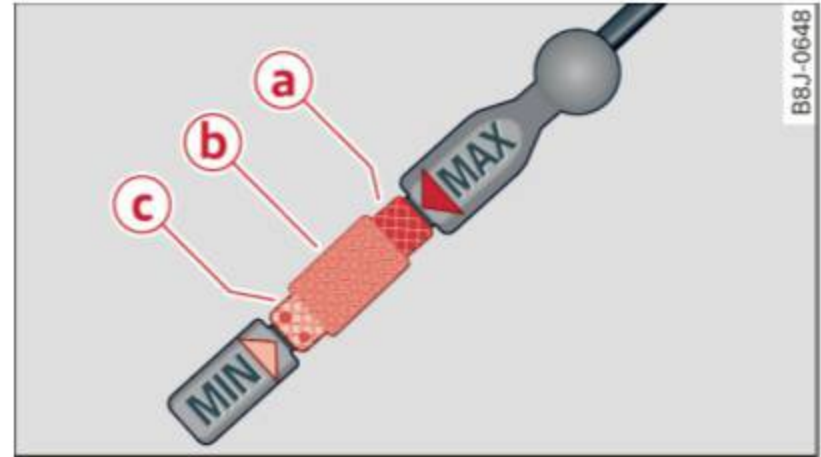

**Fig. 245** Illustration of principle 2: Markers on oil dipstick

Before you check anything in the engine compartment, **always read and heed all WARNINGS** ⇒ **! in Working in the engine compartment on page 264.**

**Determining oil level**

- ▶ Park your vehicle so that it is horizontally level.
- ▶ While at operating state temperature, briefly let the engine run at idle and then shut it off.
- ▶ Wait approx. two minutes.
- ▶ Pull out the oil dipstick. Wipe off the oil dipstick with a clean cloth, and slide it back in as far as it will go.
- ▶ Pull it back out and read off the oil level ⇒ *fig. 244* or ⇒ *fig. 245*. Top off the engine oil, if applicable ⇒ *page 270*.

**Oil level within range (a)**

- ▶ Do *not* add oil.

**Oil level within range (b)**

- ▶ You *can* add oil. Afterwards, the oil level should be within range (a).

**Oil level within range (c)**

- ▶ You *must* add oil. Afterwards, the oil level should be within range (a).

The oil level needs to be checked at regular intervals. The best times to do this are whenever you refuel and prior to long trips.

Depending on the way the vehicle is driven and the operating conditions, oil consumption can be up to 1 quart per 1,200 miles (1 liter ▶

per 2,000 km). Consumption may be higher within the first 3,000 miles (5,000 km).

### Adding engine oil



Fig. 246 Engine compartment: cover on the engine oil filler neck

Before you check anything in the engine compartment, **always read and heed all WARNINGS** ⇒  in *Working in the engine compartment* on page 264.

- ▶ Unscrew the cap  to the engine oil filling hole ⇒ *fig. 246*, ⇒ *page 266*, *fig. 243*.
- ▶ Carefully top off with the appropriate oil in 0.5 liter doses.
- ▶ Check the oil level again after two minutes ⇒ *page 269*.
- ▶ Top off the oil again, if necessary.
- ▶ Screw the cap back on the filling hole and slide the oil dipstick in as far as it will go.

### WARNING

Stop! Before working in the engine compartment, always read and heed all WARNINGS ⇒  in *Working in the engine compartment* on page 264. The engine compartment of any motor vehicle is a potentially dangerous area and can cause serious personal injury.

### WARNING

Spilled oil is a fire hazard.

- The oil filler cap must be properly secured to prevent oil from being sprayed on the hot engine and exhaust system when the engine is running.

### Note

- The oil level must not be above range 
  - danger of converter or engine damage! Contact an authorized dealership to draw off oil, if necessary.
- **Audi does not recommend the use of oil additives. They may damage the engine and adversely affect your New Vehicle Warranty.**

### For the sake of the environment

- Under no circumstances can the oil come in contact with the sewage network or the soil.
- Observe and follow legal regulations when disposing of empty oil containers.

### Changing the engine oil

*Engine oil must be changed at intervals listed in the Warranty & Maintenance booklet.*

The engine oil and oil filter must be changed according to the mileage and time intervals specified in your vehicle's Warranty & Maintenance booklet. Do not exceed these intervals – harmful sludge and deposits from old engine oil can reduce engine performance and can lead to expensive engine repairs.

Changing oil at regular intervals is so very important because the lubricating properties of oil decrease gradually during normal vehicle use. If you are not sure when to have the oil changed, ask your authorized Audi Service Advisor.

Under some circumstances the engine oil should even be changed more often than specified for normal use. Change oil more often if you often drive short distances, operate the vehicle in dusty areas or mostly under stop-and-go traffic conditions, or when you use your vehicle where temperatures stay below freezing point for long periods.

Detergent additives in the oil will make fresh oil look dark after the engine has been running for a short time. This is normal and is not ►

a reason to change the oil more often than recommended.

### WARNING

Stop! Before working in the engine compartment, always read and heed all WARNINGS ⇒  in *Working in the engine compartment on page 264*. The engine compartment of any motor vehicle is a potentially dangerous area and can cause serious personal injury.

### WARNING

If you must change the engine oil in your vehicle:

- Always wear eye protection.
- To reduce the risk of burns from hot engine oil let the engine cool down to the touch.
- When removing the oil drain plug with your fingers, stay as far away as possible. Always keep your forearm parallel to the ground to help prevent hot oil from running down your arm.
- Drain the oil into a container designed for this purpose, one large enough to hold at least the total amount of oil in your engine.
- To reduce the risk of poisoning, never use empty food or beverage containers that might mislead someone into drinking from them.
- Engine oil is poisonous. Keep it well out of the reach of children.
- Continuous contact with used engine oil is harmful to your skin. Always protect your skin by washing thoroughly with soap and water.

### Note

Never mix oil additives with your engine oil. These additives can damage your engine and adversely affect your Audi Limited New Vehicle Warranty.

### For the sake of the environment

- Before changing the oil, first make sure you know where you can properly dispose of the old oil.
- Always dispose of used oil properly. Never dump it on garden soil, in wooded areas, into streams or down sewage drains.
- Recycle used oil by taking it to a used engine oil collection facility in your area, or contact a service station.
- We strongly recommend that you have your oil changed by an authorized Audi dealer or a qualified workshop with the special tools and expertise required, and proper means of disposal.

## Engine cooling system

### Coolant

*The engine coolant performs two functions: it keeps the engine from overheating and it protects the engine from freezing in the winter.*

The cooling system is sealed and generally requires little attention.

The cooling system has been filled at the factory with a permanent coolant which does not need to be changed. The coolant consists of a mixture of water and the manufacturer's glycol-based coolant additive G13 antifreeze with anticorrosion additives (50% for USA models; 60% for Canadian models). This mixture both assures the necessary frost protection and protects metal components in the engine's cooling system from corrosion and scaling. It also raises the boiling point of the coolant.

Do not reduce the concentration of the coolant in the summer by adding plain water. **The proportion of coolant additive must be at least 50% but not more than 60%** to maintain antifreeze protection and cooling efficiency. If the coolant frost protection is too low, the coolant could freeze and damage the vehicle heating and engine cooling system. ►

For year-round driving, antifreeze is added at the factory for temperatures down to:

- - 31 °F ( - 35 °C) USA
- - 40 °F ( - 40 °C) Canada.

### WARNING

Before you check anything in the engine compartment, always read and heed all WARNINGS ⇒  in *Working in the engine compartment* on page 264.

### Note

- Before winter sets in, have the coolant checked to see if the coolant additive in your vehicle is sufficient to meet the climate conditions. This is especially important if you live in a region where the winter is extremely cold. If necessary, increase the proportion of coolant additive to 60%.
- When adding coolant additive to your cooling system, remember:
  - We recommend using only coolant additive G12++ or G13 for your vehicle. This coolant additive is available at authorized Audi dealers. Other types of antifreeze can significantly reduce corrosion protection. The resulting corrosion can cause a loss of coolant and serious engine damage.
  - Do not add any type of radiator leak sealant to your vehicle's engine coolant. Adding radiator repair fluid may adversely affect the function and performance of your cooling system and could result in damage not covered by your New Vehicle Limited Warranty.

### Checking the engine coolant level

The engine coolant level can be checked with a quick glance.



Fig. 247 Engine compartment: Coolant expansion tank

Before you check anything in the engine compartment, **always read and heed all WARNINGS** ⇒  in *Working in the engine compartment* on page 264.

- ▶ Park your vehicle on a level surface.
- ▶ Turn off the ignition.
- ▶ Let the engine cool down.
- ▶ Place a thick rag over the coolant expansion tank ⇒ *fig. 247*, ⇒ *page 266*, *fig. 243* and **carefully** twist the cap counter-clockwise ⇒ .
- ▶ Read the engine coolant level in the open coolant expansion tank. With a cold engine, the coolant level should be between the “min” and “max” markings. When the engine is warm, the level may be slightly above the “max” marking.

The location of the coolant expansion tank can be seen in the engine compartment illustration ⇒ *page 266*.

To obtain an accurate reading, the engine must be switched off.

The expansion tank in your vehicle is equipped with an electric coolant level sensor.

When the coolant level is too low, the warning light in the Auto-Check System ⇒ *page 32* will blink until you add coolant and the level has been restored to normal. Even though there is an electric coolant level sensor, we still recommend you check the coolant level from time to time. ▶

## Coolant loss

Coolant loss may indicate a **leak** in the cooling system. In the event of coolant loss, the cooling system should be inspected immediately by your authorized Audi dealer. It is not enough merely to add coolant.

In a **sealed** system, losses can occur only if the boiling point of the coolant is exceeded as a result of overheating.

### WARNING

The cooling system is under pressure and can get very hot. Reduce the risk of scalding from hot coolant by following these steps.

- Turn off the engine and allow it to cool down.
- Protect your face, hands and arms from escaping fluid and steam by covering the cap with a large, thick rag.
- Turn the cap slowly and very carefully in a counter-clockwise direction while applying light, downward pressure on the top of the cap.
- To avoid being burned, do not spill antifreeze or coolant on the exhaust system or hot engine parts. Under certain conditions, the ethylene glycol in engine coolant can catch fire.

### Note

Do not add any type of radiator leak sealant to your vehicle's engine coolant. Adding radiator repair fluid may adversely affect the function and performance of your cooling system and could result in damage not covered by your New Vehicle Limited Warranty.

## Adding coolant

*Be very careful when adding engine coolant.*

Before you check anything in the engine compartment, **always read and heed all WARNINGS** ⇒  in *Working in the engine compartment* on page 264.

- ▶ Turn off the engine.
- ▶ Let the engine cool down.
- ▶ Place a thick rag over the coolant expansion tank ⇒ *page 272, fig. 247* and **carefully** twist the cap counter-clockwise ⇒ .
- ▶ Add coolant.
- ▶ Twist the cap on again *tightly*.

Replacement engine coolant must conform to exact specifications ⇒ *page 271, Coolant*. We recommend using only coolant additive G12+, G13 or in an emergency G12+. Do **not** use a different additive. In an emergency use plain water until you can get the correct additive and can restore the correct ratio. This should be done as soon as possible.

If you have lost a considerable amount of coolant, then you should add cold antifreeze and cold water only when the engine is cold.

Always use *new* engine coolant when refilling.

Do not fill coolant above the "MAX" mark. Excess coolant will be forced out through the pressure relief valve in the cap when the engine becomes hot.

### WARNING

- The cooling system is under pressure and can get very hot. Reduce the risk of scalding from hot coolant by following these steps.
- Turn off the engine and allow it to cool down.
- Protect your face, hands and arms from escaping fluid and steam by covering the cap with a large, thick rag.
- Turn the cap slowly and very carefully in a counter-clockwise direction while applying light, downward pressure on the top of the cap.
- To avoid being burned, do not spill antifreeze or coolant on the exhaust system or hot engine parts. Under certain conditions, the ethylene glycol in engine coolant can catch fire.
- Antifreeze is poisonous. Always store antifreeze in its original container and well out of the reach of children.

- If you drain the coolant, it must be caught and safely stored in a proper container clearly marked “poison”.

### ! Note

- Coolant pollutes the environment and could cause an engine fire. Excess coolant will be forced out through the pressure relief valve in the cap when the engine becomes hot.
- If, in an emergency, only water can be added, the correct ratio between water and antifreeze ⇒ *page 271* must be restored as soon as possible.

### 🌳 For the sake of the environment

Drained coolant should not be reused. Always dispose of used coolant while observing all environmental regulations.

## Radiator fan

The radiator fan switches on automatically by itself.

The radiator fan is driven by the engine via the V-belt. The viscous clutch regulates the speed of the fan according to the temperature of the coolant.

An auxiliary electric radiator fan\* switches on and off depending on coolant temperature and other vehicle operating conditions.

After you switch the engine off, the auxiliary fan can continue running for up to 10 minutes - even with the ignition off. It can even switch on again later by itself ⇒ ⚠, if

- the temperature of the engine coolant rises due to the heat build-up from the engine in the engine compartment, or
- the engine compartment heats up because the vehicle is parked in intense sunlight.

### ⚠ WARNING

- To reduce the risk of personal injury never touch the radiator fan.

- The auxiliary electric fan is temperature controlled and can switch on suddenly even when the engine is not running.
- The auxiliary radiator fan switches on automatically when the engine coolant reaches a certain temperature and will continue to run until the coolant temperature drops.

## Brake fluid

### Checking brake fluid level

The brake fluid level can be checked with a quick glance.



Fig. 248 Engine compartment: cover on the brake fluid reservoir

Before you check anything in the engine compartment, **always read and heed all WARNINGS** ⇒ ⚠ in *Working in the engine compartment* on *page 264*.

- ▶ Read the brake fluid level from the brake fluid reservoir ⇒ *fig. 248*, ⇒ *page 266*, *fig. 243*. The brake fluid level must be between the “MIN” and “MAX” markings.

The brake fluid reservoir is located at the rear partition of the engine compartment on the left side ⇒ *page 266*.

The fluid level may drop *slightly* after some time due to the automatic adjustment of the brake pads. This is not cause for alarm.

If the brake fluid level falls *considerably* below the “MIN” mark, the brake warning/indicator light (U.S. models: **BRAKE**, Canadian models: ) will come on ⇒ *page 19* and ⇒ *page 32*. Do not continue to operate the vehicle. The complete brake system should be

thoroughly checked by an authorized Audi dealer or qualified workshop and the cause corrected. If the brake fluid level is too low, the brake warning/indicator light will illuminate. Contact an authorized Audi dealer **immediately**.

### Tips

The brake fluid reservoir is located underneath the cover.

## Changing brake fluid

*Have the brake fluid changed by an experienced technician.*

Brake fluid absorbs moisture from the air. If the water content in the brake fluid is too high, corrosion in the brake system may result after a period of time. The boiling point of the brake fluid will also decrease considerably and decrease braking performance.

Therefore, the brake fluid must be changed **every two years**. Always use new brake fluid which conforms to Federal Motor Vehicle Standard “FMVSS 116 DOT 4”.

The brake fluid reservoir can be difficult to reach, therefore, we recommend that you have the brake fluid changed by your authorized **Audi dealer**. Your dealer has the correct tools, the right brake fluid and the know-how to do this for you.

### WARNING

- Brake fluid is poisonous. It must be stored only in the closed original container out of the reach of children!
- Brake failure can result from old or inappropriate brake fluid. Observe these precautions:
  - Use only brake fluid that meets SAE specification J 1703 and conforms to Federal Motor Vehicle Standard 116. Always check with your authorized Audi dealer to make sure you are using the correct brake fluid. The correct type of

brake fluid is also indicated on the brake fluid reservoir.

- The brake fluid must be new. Heavy use of the brakes can cause a vapor lock if the brake fluid is left in the system too long. This can seriously affect the efficiency of the brakes as well as your safety. This could result in an accident.

### Note

Brake fluid will damage the paint of your vehicle.

### For the sake of the environment

Because of the problem of proper disposal of brake fluid as well as the special tools required and the necessary expertise, we recommend that you have the brake fluid changed by your authorized Audi dealer.

## Battery

### General information

Under **normal** operating conditions, the battery in your Audi does not need any maintenance. With *high* outside temperatures or long daily drives we recommend that you have the electrolyte level checked by an authorized Audi dealer or qualified workshop. The electrolyte level should also be checked each time the battery is charged ⇒ *page 277*.

Have the battery checked when you take your vehicle in for service. You are well advised to replace a battery that is older than 5 years.

With certain types of airbag deployment, the battery is disconnected from the vehicle electrical system for safety reasons ⇒  *in Repair, care and disposal of the airbags on page 198*.

### Disconnecting the battery terminals

Some vehicle functions (power window regulators, for example) are lost if the battery terminals are disconnected. These functions have to be relearned after the battery terminals are connected again. To prevent this, the battery ▶

should only be disconnected from the vehicle electrical system when absolutely necessary for repairs.

### Vehicles not driven for long periods

If you do not drive your vehicle over a period of several days or weeks, electrical components are gradually cut back or switched off. This reduces energy consumption and maintains starting capability over a longer period ⇒ *page 231*.

Take into consideration that when you unlock your vehicle, some convenience functions, such as the interior lights or the power seat adjustment, may not be available. The convenience functions will be available again when you turn on the ignition and start the engine.

### Winter operation

During the winter months, battery capacity tends to decrease as temperatures drop. This is because more power is also consumed while starting, and the headlights, rear window defogger, etc., are used more often.

Avoid unnecessary power consumption, particularly in city traffic or when traveling only short distances. Let your authorized Audi dealer check the capacity of the vehicle battery before winter sets in ⇒ *page 277*. A well charged battery will not only prevent starting problems when the weather is cold, but will also last longer.

#### **Tips**

If your vehicle is left standing for several weeks at extremely low temperatures, the vehicle battery should be removed and stored where it will not freeze. This will prevent it from being damaged and having to be replaced.

### Working on the battery

*Be especially careful when working on or near the battery.*

The battery is located under the driver's seat. Before you check anything under the driver's seat, **read and heed all WARNINGS** ⇒ .

Always heed the **safety warnings**, when working on the vehicle battery or the vehicle electrical system to prevent injury.

**The following WARNINGS are very important when working on the battery:**

**Always heed the following WARNING SYMBOLS and safety precautions when working on the battery.**



Always wear eye protection.



Battery acid contains sulfuric acid. Always wear gloves and eye protection.



No  
- sparks  
- flames  
- smoking.



When a battery is charged, it produces hydrogen gas which is explosive and could cause personal injury.



Always keep the battery well out of reach of children.



#### **WARNING**

Whenever working on the battery or on the electrical system, there is the risk of injury, accident and even fire. Read and heed the following WARNINGS:

- Always wear eye protection. Do not let battery acid or any lead particles get on your skin or clothing. Shield your eyes. Explosive gases can cause blindness or other injury.
- Battery acid contains sulfuric acid. Sulfuric acid can cause blindness and severe burns.
- Always wear gloves and eye protection. Do not tilt the battery because acid

could leak out of the ventilation openings.

- If you get battery acid in your eyes or on your skin, immediately rinse with cold water for several minutes and get medical attention.
- If you should ingest any battery acid, seek medical attention immediately.
- Do not expose the battery to an open flame, electric sparks or an open light.
- Do not smoke.
- Do not interchange the positive and negative cables.
- When working on the battery, be sure not to short-circuit the terminals with tools or other metal objects. This would cause the battery to heat up very quickly, which could lead to damage or explosion and personal injury.
- When a battery is charged, it produces hydrogen gas which is explosive and could cause personal injury.
- Always keep the battery well out of the reach of children.
- Before work is done on the electrical system, disconnect the negative ground cable.
- Before performing any work on the electrical system, switch off the engine and ignition as well as any electrical equipment. The negative cable on the battery must be disconnected. If you are just going to replace a light bulb, then it is enough to switch off the lights.
- Before disconnecting the battery, switch off the anti-theft alarm system! Otherwise you will set off the alarm.
- When disconnecting the battery, first disconnect the negative cable and then the positive cable.
- Before reconnecting the battery, make sure all electrical consumers are switched off. Reconnect the positive cable first and then the negative cable. Never interchange the cables - this could start a fire!
- Never charge a frozen or a thawed-out battery. It could explode! If a battery has frozen, then it must be replaced. A dis-

charged battery can freeze over at 32 °F (0 °C).

- Make sure the vent hose is always attached to the opening on the side of the battery.
- Never use batteries which are damaged. There is the danger of an explosion! Always replace a damaged battery.

### WARNING

California Proposition 65 Warning:

- Battery posts, terminals and related accessories contain lead and lead compounds, chemicals known to the State of California to cause cancer and reproductive problems. Wash hands after handling.

### Note

- Do not disconnect the vehicle battery when the ignition is switched on or when the engine is running, otherwise, you will damage electronic components in the electrical system.
- If your vehicle is going to stand for a long period of time without being driven, protect the battery from “freezing”, otherwise it will be damaged and will then have to be replaced.

## Battery charging

*Starting the engine requires a well charged battery.*

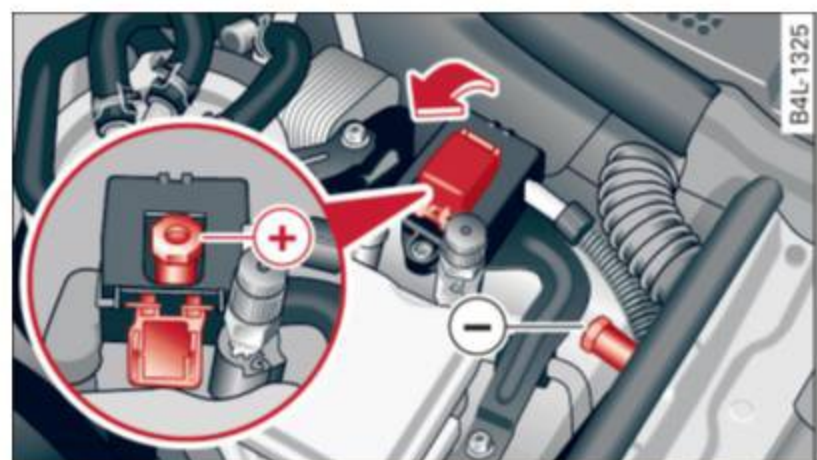

**Fig. 249** Engine compartment: Connectors for charger and jumper cables

Always read and heed all **WARNINGS** below ⇒  and ⇒  in *Working on the battery on page 276*.

- ▶ Turn off the ignition and all electrical consumers.
- ▶ Make sure the area is well ventilated when you charge the battery.
- ▶ Open the hood ⇒ *page 264*.
- ▶ Open the red cover on the positive pole ⇒ *fig. 249*.
- ▶ Connect the charger connectors according to the instructions to the **jump start bolts**. (Bolts under the red cover = “positive”, Bolts with hex head = “negative”).
- ▶ Only now plug the mains lead for the charging equipment into the wall outlet and turn it on ⇒ .
- ▶ **Make sure the charging rate is not over 30 amps/14.8 Volt.**
- ▶ When the battery is fully charged: Turn the charging equipment off and remove the mains lead from the wall outlet.
- ▶ Now remove the clamps for the charging equipment.
- ▶ Close the red cover on the positive pole.
- ▶ Close the hood ⇒ *page 264*.

A discharged battery can **freeze** at temperatures of only 0 °C. Allow a frozen battery to thaw completely before attempting to charge it ⇒ . However, we recommend not using a thawed battery again because the battery casing can be cracked due to ice formation and can leak battery acid.

### Battery charging (Maximum charging rate of 30 amps/14.8 Volt)

When charging at *low* voltages (e.g. with a **trickle charger**), the battery cables do not have to be disconnected first. The battery caps should *not* be opened when charging a battery.

It is not necessary to remove the battery from the luggage compartment.

### Fast charging the battery (charging rate above 14.8 Volts)

For technical reasons do not use a battery charger that uses voltage greater than 14.8 Volts to charge your vehicle's battery.

#### **WARNING**

- Charging a battery can be dangerous.
- Always follow the operating instructions provided by the battery charger manufacturer when charging your battery.
  - Never charge a frozen battery. It may explode because of gas trapped in the ice. Allow a frozen battery to thaw out first.
  - Do not reuse batteries which were frozen. The battery housing may have cracked and weakened when the battery froze.
  - Charge the battery in a well ventilated area. Keep away from open flame or electrical spark. Do not smoke. Hydrogen gas generated by the battery is explosive.
  - To reduce the danger of explosion, never connect or disconnect charger cables while the charger is operating.
  - Fast charging a battery is dangerous and should only be attempted by a competent technician with the proper equipment.
  - Battery acid that may spill during charging should be washed off with a solution of warm water and baking soda to neutralize the acid.

#### **Note**

Never use a fast charger as a booster to start the engine. This will seriously damage sensitive electronic components, such as control units, relays, radio, etc., as well as the battery charger.

## Battery replacement

The new battery must have the same specifications and dimensions as the original equipment battery.

Intelligent energy management in your vehicle is responsible for distributing the electrical energy throughout your vehicle ⇒ *page 231*. The intelligent energy management system will keep the engine battery charged better than vehicles without this system. To make sure the additional electrical energy is available once again after you have changed the battery, we recommend that you install batteries of the same type and manufacture only (the same as those installed at the time your vehicle was delivered). Specifications are listed on the battery housing. Your authorized dealer must code the battery in the energy management system to enable you to use the energy management functions correctly after replacing the battery.

If it is not possible to use a battery of this type, the new battery must have the same capacity, voltage (12 volts), amperage, construction and plug sealing.

When installing the battery, make sure the ignition and all electrical consumers are turned off.

### ! Note

Make sure the ventilation hose on the side of the battery is connected, otherwise fumes or battery acid can leak out.

### 🌳 For the sake of the environment

Because of the problem of proper disposal of a battery, we recommend your authorized Audi dealer change the battery for you. Batteries contain sulfuric acid and lead and must always be disposed of properly in compliance with all environmental regulations. Disposing of vehicle batteries improperly is very dangerous to the environment.

## Windshield/headlight washer container



Fig. 250 Engine compartment: cover on the windshield and headlight\* washer fluid reservoir

The washer fluid container is marked with the symbol  on its cap ⇒ *fig. 250*, ⇒ *page 266*, *fig. 243*.

- ▶ Before you check anything in the engine compartment, **always read and heed all WARNINGS** ⇒  in *Working in the engine compartment on page 264*.
- ▶ Lift the filler cap tongue to add washer fluid. You can fill the container to the top.
- ▶ Press the cap back onto the filler neck after filling the container.

You can find the reservoir **capacity** in the table in ⇒ *page 322*.

Clean water should be used when filling up. If possible, use soft water to prevent scaling on the washer jets. Always add a glass cleaner solution (with frost protection in the winter).

### ! Note

Do not mix engine coolant antifreeze or any other additives to fill up the windshield washer reservoir.

## Tires and wheels

### Tires

#### General notes

*Tires may be the least appreciated and most abused parts of a motor vehicle.*

Tires may be the least appreciated and most abused parts of a motor vehicle. Tires are, however, one of the most important parts of a vehicle, particularly considering the comparatively small patch of rubber on each tire that assures that all-important contact between you, your vehicle and the road.

Maintaining the correct tire pressure, making sure that your vehicle and its tires do not have to carry more weight than they can safely handle, avoiding damage from road hazards and regularly inspecting tires for damage including cuts, slashes irregular wear and overall condition are the most important things that you can do to help avoid sudden tire failure including tread separation and blowouts.

#### Avoiding damage

If you have to drive over a curb or similar obstacle, drive very slowly and as close as possible at a right angle to the curb.

Always keep chemicals including grease, oil, gasoline and brake fluid off the tires.

Inspect the tires regularly for damage (cuts, cracks or blisters, etc.). Remove any foreign bodies embedded in the treads.

#### Storing tires

Mark tires when you remove them to indicate the direction of rotation. This ensures you to be able to mount them correctly when you re-install them.

When removed, the wheels or tires should be stored in a cool, dry and preferably dark place.

Store tires in a vertical position if they are not mounted on rims, in a horizontal position if they are mounted on rims.

#### New tires

New tires have to be broken in ⇒ .

The tread depth of new tires may vary, according to the type and make of tire and the tread pattern.

#### Hidden damage

Damage to tires and rims is often not readily visible. If you notice unusual vibration or the vehicle pulls to one side, this may indicate that one of the tires has been damaged. The tires must be checked immediately by an authorized Audi dealer or qualified workshop.

#### Unidirectional tires

A unidirectional tire can be identified by arrows on the sidewall, that point in the direction the tire is designed to rotate. You must follow the specified direction of rotation. This is necessary so that these tires can develop their optimum characteristics regarding grip, road noise, wear and hydroplaning resistance. For more information ⇒ *page 308*.



#### WARNING

New tires or tires that are old, worn or damaged cannot provide maximum control and braking ability.

- New tires tend to be slippery and must be broken in. To reduce the risk of losing control, a collision and serious personal injuries, drive with special care for the first 350 miles (560 km).
- Driving with worn or damaged tires can lead to loss of control, sudden tire failure, including a blowout and sudden deflation, crashes and serious personal injuries. Have worn or damaged tires replaced immediately.
- Tires age even if they are not being used and can fail suddenly, especially at high speeds. Tires that are more than 6 years old can only be used in an emergency and then with special care and at low speed.

– Never mount used tires on your vehicle if you are not sure of their “previous history.” Old used tires may have been damaged even though the damage cannot be seen that can lead to sudden tire failure and loss of vehicle control.

– If you notice unusual vibration or if the vehicle pulls to one side when driving, always stop as soon as it is safe to do so and check the wheels and tires for damage.

## Glossary of tire and loading terminology

### Accessory weight

means the combined weight (in excess of those standard items which may be replaced) of automatic transmission, power steering, power brakes, power windows, power seats, radio, and heater, to the extent that these items are available as factory-installed equipment (whether installed or not).

### Aspect ratio

means the ratio of the height to the width of the tire in percent. Numbers of 55 or lower indicate a low sidewall for improved steering response and better overall handling on dry pavement.

### Bead

means the part of the tire that is made of steel wires, wrapped or reinforced by ply cords and that is shaped to fit the rim.

### Bead separation

means a breakdown of the bond between components in the bead.

### Cord

means the strands forming the plies in the tire.

### Cold tire inflation pressure

means the tire pressure recommended by the vehicle manufacturer for a tire of a designated size that has not been driven for more than a couple of miles (kilometers) at low speeds in the three hour period before the tire pressure is measured or adjusted.

### Curb weight

means the weight of a motor vehicle with standard equipment including the maximum capacity of fuel, oil, and coolant, air conditioning and additional weight of optional equipment.

### Extra load tire

means a tire design to operate at higher loads and at higher inflation pressures than the corresponding standard tire. Extra load tires may be identified as “XL”, “xl”, “EXTRA LOAD”, or “RF” on the sidewall.

### Gross Axle Weight Rating (“GAWR”)

means the load-carrying capacity of a single axle system, measured at the tire-ground interfaces.

### Gross Vehicle Weight Rating (“GVWR”)

means the maximum total loaded weight of the vehicle.

### Groove

means the space between two adjacent tread ribs.

### Load rating (code)

means the maximum load that a tire is rated to carry for a given inflation pressure. You may not find this information on all tires because it is not required by law.

### Maximum load rating

means the load rating for a tire at the maximum permissible inflation pressure for that tire.

**Maximum loaded vehicle weight**

means the sum of:

- (a) Curb weight
- (b) Accessory weight
- (c) Vehicle capacity weight, and
- (d) Production options weight

**Maximum (permissible) inflation pressure**

means the maximum cold inflation pressure to which a tire may be inflated. Also called “maximum inflation pressure.”

**Normal occupant weight**

means 150 lbs. (68 kilograms) times the number of occupants seated in the vehicle up to the total seating capacity of your vehicle.

**Occupant distribution**

means distribution of occupants in a vehicle.

**Outer diameter**

means the overall diameter of an inflated new tire.

**Overall width**

means the linear distance between the exteriors of the sidewalls of an inflated tire, including elevations due to labeling, decorations, or protective bands or ribs.

**Ply**

means a layer of rubber-coated parallel cords.

**Production options weight**

means the combined weight of those installed regular production options weighing over 5 lbs. (2.3 kg) in excess of those standard items which they replace, not previously considered in curb weight or accessory weight, including heavy duty brakes, ride levelers, roof rack, heavy duty battery, and special trim.

**Radial ply tire**

means a pneumatic tire in which the ply cords that extend to the beads are laid at substantially 90 degrees to the centerline of the tread.

**Recommended inflation pressure**

see ⇒ *page 281, Cold tire inflation pressure.*

**Reinforced tire**

means a tire design to operate at higher loads and at higher inflation pressures than the corresponding standard tire. Reinforced tires may be identified as “XL”, “xl”, “EXTRA LOAD”, or “RF” on the sidewall.

**Rim**

means a metal support for a tire or a tire and tube assembly upon which the tire beads are seated.

**Rim diameter**

means nominal diameter of the bead seat. If you change your wheel size, you will have to purchase new tires to match the new rim diameter.

**Rim size designation**

means rim diameter and width.

**Rim width**

means nominal distance between rim flanges.

**Sidewall**

means that portion of a tire between the tread and bead.

**Speed rating (letter code)**

means the speed at which a tire is designed to be driven for extended periods of time. The ratings range from 93 mph (150 km/h) to 186 mph (298 km/h) ⇒ *page 292*. You may not find this information on all tires because it is not required by law.

The speed rating letter code, where applicable, is molded on the tire sidewall and indicates the maximum permissible road speeds ⇒  *in Winter tires on page 296.*

**Tire pressure monitoring system**

means a system that detects when one or more of a vehicle's tires are underinflated and illuminates a low tire pressure warning tell-tale. ►

**Tread**

means that portion of a tire that comes into contact with the road.

**Tread separation**

means pulling away of the tread from the tire carcass.

**Treadwear indicators (TWI)**

means the projections within the principal grooves designed to give a visual indication of the degrees of wear of the tread. See ⇒ *page 290, Tread Wear Indicator (TWI)* for more information on measuring tire wear.

**Uniform Tire Quality Grading**

is a tire information system developed by the United States National Highway Traffic Safety Administration (NHTSA) that is designed to help buyers make relative comparisons among tires. The UTQG is not a safety rating and not a guarantee that a tire will last for a prescribed number of miles (kilometers) or perform in a certain way. It simply gives tire buyers additional information to combine with other considerations, such as price, brand loyalty and dealer recommendations. Under UTQG, tires are graded by the tire manufacturers in three areas: treadwear, traction, and temperature resistance. The UTQG information on the tires, molded into the sidewalls.

**U.S. DOT Tire Identification Number (TIN)**

This is the tire's "serial number" It begins with the letters "DOT" and indicates that the

tire meets all federal standards. The next two numbers or letters indicate the plant where it was manufactured, and the last four numbers represent the week and year of manufacture. For example,

**DOT ... 2212 ...**

means that the tire was produced in the 22nd week of 2012. The other numbers are marketing codes that may or may not be used by the tire manufacturer. This information is used to contact consumers if a tire defect requires a recall.

**Vehicle capacity weight**

means the rated cargo and luggage load plus 150 lbs. (68 kilograms) times the vehicle's total seating capacity as listed on the label located on the driver's side B-pillar.

**Vehicle maximum load on the tire**

means that load on an individual tire that is determined by distributing to each axle its share of the maximum loaded vehicle weight and dividing by two.

**Vehicle normal load on the tire**

means that load on an individual tire that is determined by distributing to each axle its share of the curb weight, accessory weight, and normal occupant weight (distributed in accordance with table below ⇒ *page 283*) and dividing by two.

**Occupant loading and distribution for vehicle normal load for various designated seating capacities**

| Designated seating capacity, number of occupants | Vehicle normal load, number of occupants | Occupant distribution in a normally loaded vehicle |
|--|--|--|
| 5/6*/7*  | 3  | 2 in front, 1 in second seat                       |

## Cold tire inflation pressure

Tire pressure affects the overall handling, performance and safety of a vehicle.



Fig. 251 Tire pressure label: located on driver's side B-pillar

Tire pressure generally refers to the amount of air in a tire that it needs it to do its job and safely carry the combined load of the entire vehicle and its contents. Tire pressure is measured in kilopascals (kPa), the international measuring unit and in pounds per square inch (PSI). Tire pressure is based in part on the vehicle's design and load limit – the greatest amount of weight that the vehicle can carry safely and the tire size. The proper tire pressure is frequently referred to as the “recommended cold tire inflation pressure.” Air in the tires expands when the tire heats up because of internal friction when it flexes in use. The tire pressure is higher when the tire has warmed up than when it is “cold.” It is the inflation pressure in a “cold” tire that counts. Therefore, you should never let air out of a warm tire to match “cold tire inflation pressure” recommendations. The tires would then be underinflated and could fail suddenly.

Maintaining proper tire pressure is one of the most important things you can do to help avoid sudden tire failure. Underinflated tires are a major cause of sudden tire failure. Keeping tires at the right pressure is also important for safe and responsive vehicle handling, traction, braking and load carrying. **Tire pressures are particularly important when the vehicle is being driven at higher speeds, and then especially when heavily loaded even within the permissible load-carrying capacities approved for your vehicle.**

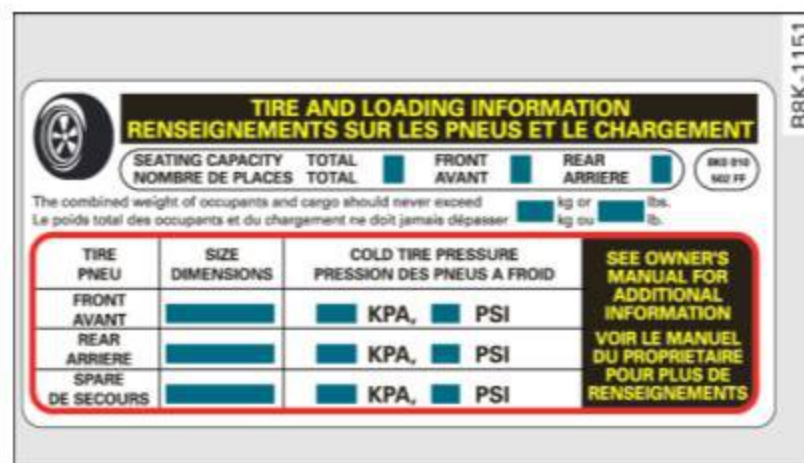

Fig. 252 Tire pressure label

The recommended tire pressures for your Audi depend on the kind of tires on your vehicle and the number of passengers and/or amount of luggage you will be transporting.

The tire pressure label is located on the driver's side B-pillar. The tire pressure label lists the recommended cold tire inflation pressures for the vehicle at its maximum capacity weight and tires that were on your vehicle at the time it was manufactured.

**If you wish to improve comfort when operating the vehicle at normal load (up to 3 occupants), you can adjust tire pressures to those specified for normal vehicle load. Before operating the vehicle at maximum load, you must increase the tire pressures to those specified for maximum vehicle load ⇒ ⚠.**

Bear in mind that the tire pressure monitoring system can only monitor the tire pressures you have stored. The system does not recognize the load condition of your vehicle.

The effectiveness of the tire pressure monitoring system will be impaired if you store normal load pressures but then operate the vehicle at its maximum load ⇒ ⚠.

See the illustration ⇒ *fig. 251* for the location of the label on driver's side B-pillar (color of the actual label and exact location on the vehicle will vary slightly).

Note that the following table is accurate at the time of going to press and is subject to

change. In the event of discrepancies, the tire pressure label located on the driver's side B-pillar always takes precedence.

The table below lists the recommended cold tire inflation pressures for the Audi model

| Model/<br>Engine               | Tire designation                       | Tire pressure         |     |      |     |                     |     |      |     |
|--------------------------------|--|-----------------------|-----|------|-----|---------------------|-----|------|-----|
|                                |  | normal load condition |     |      |     | full load condition |     |      |     |
|                                |  | front                 |     | rear |     | front               |     | rear |     |
|                                |  | PSI                   | kPA | PSI  | kPA | PSI                 | kPA | PSI  | kPA |
| Q7:<br>3.0 liter<br>6-cylinder | 255/55 R18 109H XL<br>All Season       | 35                    | 240 | 35   | 240 | 44                  | 300 | 49   | 340 |
|                                | 265/50 R19 110H XL<br>All Season       | 35                    | 240 | 35   | 240 | 44                  | 300 | 49   | 340 |
|                                | 275/45 R20 110H XL<br>All Season       | 35                    | 240 | 35   | 240 | 44                  | 300 | 49   | 340 |
|                                | 275/45 R20 110Y XL<br>High Performance | 35                    | 240 | 35   | 240 | 44                  | 300 | 49   | 340 |
|                                | 295/35 R21 107Y XL<br>High Performance | 36                    | 250 | 35   | 240 | 44                  | 300 | 49   | 340 |

**XL = reinforced or extra load tire. It may also appear as xl, EXTRA LOAD, or RF on the tire sidewall.**

The correct tire pressure for the *spare wheel* is located on a label on the driver's side B-pillar.

Because technical changes may be made to vehicle equipment during the model year, always compare the tire size designation on the tire pressure label on your vehicle with the tires on your vehicle. Make sure that the tire size information on the vehicle label is the same as the size of the tires on the vehicle. This is especially important if the vehicle belongs to someone else or you bought the vehicle with different rims/tires or you bought the vehicle as a previously owned vehicle.

Remember, your safety and that of your passengers also depends on making sure that load limits are not exceeded. Vehicle load includes everybody and everything in and on the vehicle. These load limits are technically referred to as the vehicle's Gross Vehicle Weight Rating ("GVWR"). The Gross Axle Weight Rating ("GAWR") is the maximum load that can be applied at each of the vehicle's two axles. The Gross Vehicle Weight Rating and the

covered by your Owner's Literature at the vehicle's capacity weight and the tire sizes installed on the respective models as original equipment, or as a factory option.

Gross Axle Weight Rating are listed on the safety compliance sticker label located on the driver's side B-pillar. The tire pressure label on your Audi lists the maximum combined weight of all of the occupants and luggage or other cargo that the vehicle can carry. For the location of the tire pressure label ⇒ *fig. 251*.

 **WARNING**

Overloading a vehicle can cause loss of vehicle control, a crash or other accident, serious personal injury, and even death.

- Carrying more weight than your vehicle was designed to carry will prevent the vehicle from handling properly and increase the risk of a loss of vehicle control.
- The brakes on a vehicle that has been overloaded may not be able to stop the vehicle within a safe distance.
- Tires on a vehicle that has been overloaded can fail suddenly causing loss of control and a crash.

- Always make sure that the total load being transported – including the weight of a trailer hitch and the tongue weight of a loaded trailer – does not make the vehicle heavier than the vehicle's Gross Vehicle Weight Rating.

### WARNING

- Incorrect tire pressures and/or underinflation can lead to a serious or fatal accident.
- Incorrect tire pressures and/or underinflation cause increased tire wear and can affect the handling of the vehicle.
- Incorrect tire pressures and/or underinflation can also lead to sudden tire failure, including a blowout and sudden deflation, causing loss of vehicle control.

### Checking tire pressure

*The correct tire pressure for the tires originally installed on your vehicle is listed on the tire pressure label located on driver's side B-pillar.*

The recommended tire pressures are on the tire pressure label and in the table ⇒ *page 284, Cold tire inflation pressure*. This means that the pressure must be checked and adjusted when the tire has not been driven for more than a couple of miles (kilometers) at low speeds during the previous three hours. Air in the tires expands when the tire heats up as a result of internal friction as it flexes in use. The tire pressure is higher when the tire has warmed up than when it is "cold."

It is the inflation pressure in a "cold" tire that counts. Therefore, you should never let air out of a warm tire to match "Cold tire inflation pressure" recommendations ⇒ *page 284*. The tires would then be underinflated and could fail suddenly.

The tire pressure label on your Audi lists the recommended cold tire inflation pressures at maximum capacity for the new, original equipment tires that were on your vehicle at

the time it was manufactured. For the location of the label ⇒ *page 284, fig. 251*.

Most tires lose air naturally over time. They can also lose some air if you drive over a pothole or hit a curb while parking. It is usually not possible to see whether the radial tires used today are underinflated just by looking at them.

Therefore, be sure to check tire pressures at least once a month and always before going on a long trip. Make sure to take the number of people and the amount of luggage into account when adjusting tire pressure for a trip – even one that you would not consider to be "long." See ⇒ *page 288, Tires and vehicle load limits* for more important information.

Always use an accurate tire pressure gauge when checking and adjusting inflation pressures. Check all of the tires and be sure not to forget the spare tire. If the pressure in any tire is too high when the tire is "cold," let air out of the tire slowly with the edge of the tire gauge and keep checking the pressure until you reach the pressure that is correct for the load (passengers and luggage) and kind of driving you plan to do.

If the pressure in any tire is too low, note the difference between the pressure in the cold tire and the pressure you need and add the air that you need to reach the correct pressure for the vehicle load (passengers and luggage) for the tires on your vehicle as listed on the on your vehicle and in this manual and the kind of driving you plan to do.

**Never exceed the maximum inflation pressure listed on the tire sidewall for any reason.**

Remember that the vehicle manufacturer, not the tire manufacturer, determines the correct tire pressure for the tires on your vehicle.

It is important to check the tire pressure when the tires are cold.

- Read the required tire pressure from the tire pressure label. The tire pressure label is located on the driver's side B-pillar. The tire

pressure label lists the recommended cold tire inflation pressures for the vehicle at its maximum capacity weight and the tires that were on your vehicle at the time it was manufactured. For recommended tire pressures for normal load conditions, please see chapter ⇒ *page 284*.

- Turn the valve stem cap counter-clockwise to remove it from the tire valve.
- Place the air pressure gauge on the valve.
- The tire pressures should only be checked and adjusted when the tires are cold. The slightly raised pressures of warm tires must not be reduced.
- Adjust the tire pressure to the load you are carrying.
- Reinstall the valve stem cap on the valve.

### When should I check the tire pressure?

The correct tire pressure is especially important at high speeds. The pressure should therefore be checked at least once a month and always before starting a journey. Do not forget to check the tire pressure for the spare wheel.

### When should I adjust the tire pressures?

Adjust the tire pressure to the load you are carrying. After changing a wheel **or** replacing wheels you have to adjust the tire pressures on all wheels. In addition, you must then store the new tire pressures in the tire pressure monitoring system ⇒ *page 300*.

#### **WARNING**

Incorrect tire pressures and/or underinflation can lead sudden tire failure, loss of control, collision, serious personal injury or even death.

- When the warning symbol  appears in the instrument cluster, stop and inspect the tires.
- Incorrect tire pressure and/or underinflation can cause increased tire wear and can affect the handling of the vehicle and stopping ability.
- Incorrect tire pressures and/or underinflation can also lead to sudden tire fail-

ure, including a blowout and sudden deflation, causing loss of vehicle control.

- The driver is responsible for the correct tire pressures for all tires on the vehicle. The applicable pressure values are located on a sticker on the driver's side B-pillar.
- Only when all tires on the vehicle are filled to the correct pressure, the tire pressure monitoring system can work correctly.
- The use of incorrect tire pressure values can lead to accidents or other damage. Therefore it is essential that the driver observe the specified tire pressure values for the tires and the correct pressures for the function of the tire pressure monitoring system.
- Always inflate tires to the recommended and correct tire pressure before driving off.
- Driving with underinflated tires bend more, letting them get too hot resulting in tread separation, sudden tire failure and loss of control.
- Excessive speed and/overloading can cause heat build-up, sudden tire failure and loss of control.
- If the tire pressure is too low or too high, the tires will wear prematurely and the vehicle will not handle well.
- If the tire is not flat and you do not have to change a wheel immediately, drive at reduced speed to the nearest service station to check the tire pressure and add air as required.

#### **Note**

Driving without valve stem caps can cause damage to the tire valves. To prevent this, always make sure that factory installed valve stem caps on all wheels are securely mounted on the valve.

#### **For the sake of the environment**

Underinflated tires will also increase the fuel consumption.

### Tires and vehicle load limits

There are limits to the amount of load or weight that any vehicle and any tire can carry. A vehicle that is overloaded will not handle well and is more difficult to stop. Overloading can not only lead to loss of vehicle control, but can also damage important parts of the vehicle and can lead to sudden tire failure, including a blowout and sudden deflation that can cause the vehicle to crash.

Your safety and that of your passengers also depends on making sure that load limits are not exceeded. Vehicle load includes everybody and everything in and on the vehicle. These load limits are technically referred to as the vehicle's **Gross Vehicle Weight Rating** ("GVWR").

The "GVWR" includes the weight of the basic vehicle, all factory installed accessories, a full tank of fuel, oil, coolant and other fluids plus maximum load. The maximum load includes the number of passengers that the vehicle is intended to carry ("seating capacity") with an assumed weight of 150 lbs (68 kg) for each passenger at a designated seating position and the total weight of any luggage in the vehicle. If you tow a trailer, the weight of the trailer hitch and the tongue weight of the loaded trailer must be included as part of the vehicle load.

The **Gross Axle Weight Rating** ("GAWR") is the maximum load that can be applied at each of the vehicle's two axles.

The Gross Vehicle Weight Rating and the Gross Axle Weight Rating are listed on the safety compliance sticker label located on the driver's side B-pillar. Your Audi has 5 seating positions, 2 in the front and 3 in the rear for total seating capacity of 5. On vehicles with six seats\*, your vehicle has two front seats, two seats in the second row seating and two seats in the third row seating. On vehicles with seven seats\*, your vehicle has two front seats, three seats in the second row seating and two seats in the third row seating. Each

seating position has a seat belt ⇒ *page 175, Safety belts.*

The fact that there is an upper limit to your vehicle's Gross Vehicle Weight Rating means that the total weight of whatever is being carried in the vehicle (including the weight of a trailer hitch and the tongue weight of the loaded trailer) is limited. The more passengers in the vehicle or passengers who are heavier than the standard weights assumed mean that less weight can be carried as luggage.

The tire pressure label on your Audi also lists the maximum combined weight of all of the occupants and luggage or other cargo that the vehicle can carry. For the location of the label ⇒ *page 284, fig. 251.*



#### WARNING

Overloading a vehicle can cause loss of vehicle control, a crash or other accident, serious personal injury, and even death.

- Carrying more weight than your vehicle was designed to carry will prevent the vehicle from handling properly and increase the risk of the loss of vehicle control.
- The brakes on a vehicle that has been overloaded may not be able to stop the vehicle within a safe distance.
- Tires on a vehicle that has been overloaded can fail suddenly, including a blowout and sudden deflation, causing loss of control and a crash.
- Always make sure that the total load being transported – including the weight of a trailer hitch and the tongue weight of a loaded trailer – does not make the vehicle heavier than the vehicle's Gross Vehicle Weight Rating.

### Determining correct load limit

Use the example below to calculate the total weight of the passengers and luggage or

other things that you plan to transport so that you can make sure that your vehicle will not be overloaded.

### Steps for Determining Correct Load Limit

1. Locate the statement “THE COMBINED WEIGHT OF OCCUPANTS AND CARGO SHOULD NEVER EXCEED XXX KG OR XXX LBS” on your vehicle’s placard (tire inflation pressure label) ⇒ *page 284, fig. 251.*
2. Determine the combined weight of the driver and passengers that will be riding in your vehicle.
3. Subtract the combined weight of the driver and passengers from “XXX” kilograms or “XXX” pounds shown on the sticker ⇒ *page 284, fig. 251.*
4. The resulting figure equals the available amount of cargo and luggage load capacity. For example, if the “XXX” amount equals 1400 lbs. and there will be five 150 lbs. passengers in your vehicle, the amount of available cargo and luggage load capacity is 650 lbs. (1400-750 (5 x 150) = 650 lbs.)
5. Determine the combined weight of luggage and cargo being loaded on the vehicle. That weight may not safely exceed the available cargo and luggage load capacity calculated in Step 4.
6. If your vehicle will be towing a trailer, load from your trailer will be transferred to your vehicle. Consult this manual to determine how this reduces the available cargo and luggage load capacity of your vehicle.
  - ▶ Check the tire sidewall (⇒ *page 291, fig. 255*) to determine the designated load rating for a specific tire.

### Tire service life

The service life of tires depends on a lot of different things including proper installation and balancing, correct tire pressure and driving style.



Fig. 253 Tire tread: tread wear indicators (TWI)

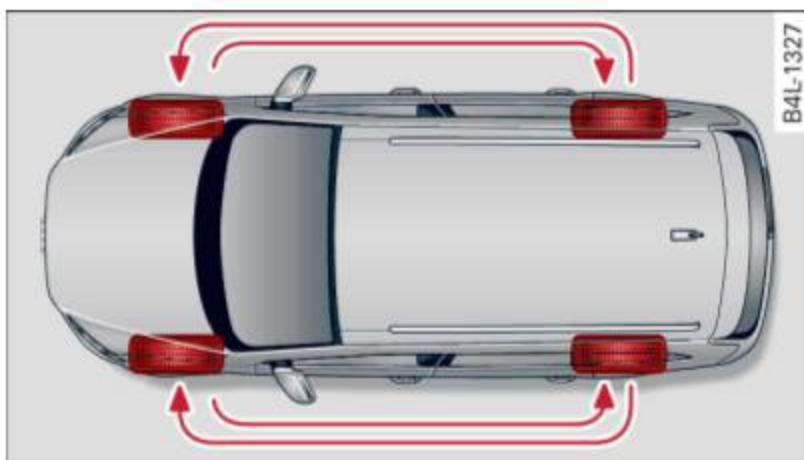

Fig. 254 Rotating tires for more even wear

### Tread Wear Indicator (TWI)

The original tires on your vehicle have 1/16 inch (1.6 mm) high “wear indicators” ⇒ *fig. 253* running across the tread. Depending on the make, there will be six to eight of them evenly placed around the tire. Marks on the tire sidewall (for example “TWI” or other symbols) indicate the positions of the tread wear indicators. Worn tires must be replaced. Different figures may apply in other countries ⇒ ⚠.

### Tire pressure

Incorrect tire pressure causes premature wear and can cause sudden tire blow-out. For this reason, tire pressure must be checked at least once a month ⇒ *page 286*.

### Driving style

Driving fast around curves, heavy acceleration and hard braking increase tire wear.

### Rotating tires for more even wear

For all four tires on your vehicle to have the same service life, we recommend that the front and rear tires are rotated according to the tire manufacturer's suggested tire rotation intervals. Please remember the following:

- Tire rotation intervals may differ from the vehicle service intervals outlined in your Warranty & Maintenance booklet.
- The longer one tire is used in one location on the vehicle, the more it wears at certain points; therefore, we recommend that you follow the tire manufacturer's suggested tire rotation intervals.
- Vehicles with front-wheel drive experience more tread wear on the front wheels compared to all-wheel drive (quattro®).
- Please rotate tires as shown ⇒ *fig. 254*.
- Extra care must be taken when rotating direction-specific tires ⇒ *page 308*.

### Wheel balancing

The wheels on new vehicles are balanced. However, various situations during everyday driving can cause them to become unbalanced, resulting in vibrations you can usually feel through the steering wheel.

Unbalanced wheels must be rebalanced to avoid excessive wear on steering, suspension and tires. A wheel must also be rebalanced when a new tire is installed.

### Incorrect wheel alignment

Incorrect wheel alignment can cause excessive tire wear, impairing the safety of the vehicle. If tires show excessive wear, have the wheel alignment checked by an authorized Audi dealer or qualified workshop.

### All-wheel drive

Vehicles with quattro® must always have tires of the same size, construction and tread type. For details see ⇒ *page 231*. ▶

**! WARNING**

- Sudden tire failure can lead to loss of control, a crash and serious personal injury!
- Never drive a vehicle when the tread on any tire is worn down to the wear indicators.
  - Worn tires are a safety hazard, they do not grip well on wet roads and increase your risk of “hydroplaning” and loss of control.
  - Always keep chemicals that can cause tire damage, such as grease, oil, gasoline and brake fluid away from tires.
  - Tires age even if they are not being used and can fail suddenly, especially at high speeds. Tires that are more than 6 years old can only be used in an emergency and then with special care and at lower speeds.
  - Never mount used tires on your vehicle if you are not sure of their “previous history.” Old used tires may have been damaged even though the damage cannot be seen that can lead to sudden tire failure and loss of vehicle control.

**New tires and replacing tires and wheels**

*New tires and wheels have to be broken in.*

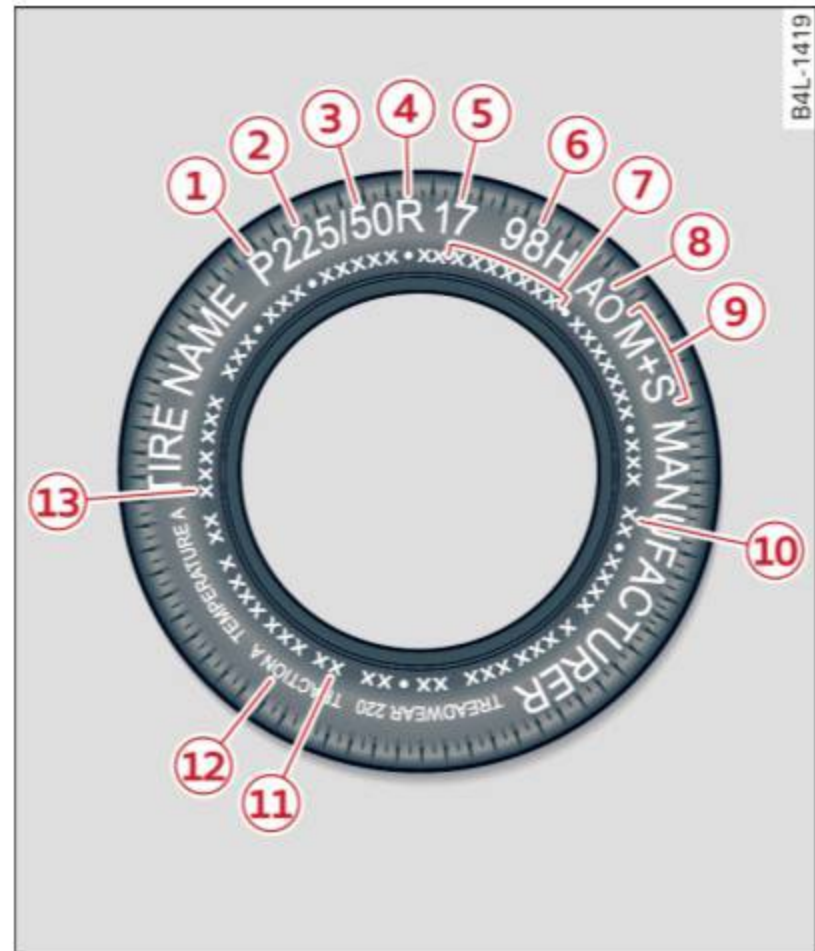

**Fig. 255** Tire specification codes on the sidewall of a tire

| No. | Description                                |
|-----|--|
| ①   | Passenger car tire (where applicable)      |
| ②   | Nominal width of tire in millimeters       |
| ③   | Ratio of height to width (aspect ratio)    |
| ④   | Radial                                     |
| ⑤   | Rim diameter code                          |
| ⑥   | Load index and speed rating                |
| ⑦   | U.S. DOT tire identification number        |
| ⑧   | Audi Original tire                         |
| ⑨   | Sever snow conditions                      |
| ⑩   | Tire ply composition and materials used    |
| ⑪   | Maximum load rating                        |
| ⑫   | Treadwear, traction and temperature grades |
| ⑬   | Maximum permissible inflation pressure     |

The tires and rims are essential parts of the vehicle's design. The tires and rims approved by Audi are specially matched to the characteristics of the vehicle and can make a major

contribution to good road holding and safe handling when in good condition and properly inflated ⇒ .

We recommend that all work on tires and wheels be performed by an authorized Audi dealer. They are familiar with recommended procedures and have the necessary special tools and spare parts as well as the proper facilities for disposing of the old tires.

Authorized Audi dealers have the necessary information about technical requirements for installing or changing tires and rims.

### Replacing tires and wheels

Tires should be replaced at least in pairs and not individually (for example both front tires or both rear tires together).

Be sure to read and heed the information to the tire pressure monitoring system ⇒ *page 298*.

Always buy replacement radial tires that have the same specifications as the tires approved for your vehicle by Audi. Replacement tires must always have the same load rating specification as the original equipment or approved optional tires listed in the table ⇒ *page 284*.

Audi-approved specification tires are specially matched to your vehicle and its load limits, and can contribute to the important roadholding, driving characteristics, and safety of the vehicle. The table (⇒ *page 284*) lists specifications of the tires approved for the Audi models covered by your Owner's Literature.

The tire pressure label located on the driver's side B-pillar ⇒ *page 284, fig. 252* lists the specifications of the original equipment tires installed on your vehicle at the time it was manufactured.

Federal law requires tire manufacturers to place standardized information on the sidewall of all tires ⇒ *fig. 255*. This information identifies and describes the fundamental characteristics, the quality grade of the tire and also provides a tire identification number

for safety standard certification and in case of a recall.

### Tire specifications

Knowledge of tire specifications makes it easier to choose the correct tires. Radial tires have the tire specifications marked on the sidewall, for example:

#### **P255 / 55 R 18 109 H XL**

This contains the following information:

- P** Indicates the tire is for passenger cars (where applicable)
- 255** Nominal tire width in mm of the tire from sidewall edge to sidewall edge. In general, the larger the number, the wider the tire
- 55** Height/width ratio in percent (aspect ratio)
- R** Tire construction: **Radial**
- 18** Rim diameter code (in inches)
- 109** Load rating code
- H** Speed rating letter code
- XL** (or "xl", "EXTRA LOAD", or "RF" Indicates that the tire is a "Reinforced" or an "Extra Load" tire
- M+S** (or "M/S") Indicates that the tire has some mud and snow capability

The tires could also have the information of direction of rotation ⇒ *page 280*.

### Tire manufacturing date

The manufacturing date is also indicated on the tire sidewall (possibly only on the *inner* side of the wheel):

"DOT ... 2212..." means, for example, that the tire was produced in the 22nd week of 2012.

### Speed rating (letter code)

The speed rating letter code on the wheels indicates the maximum permissible road speeds ⇒  in *Winter tires on page 296*.

- P** up to 93 mph (150 km/h)
- Q** up to 99 mph (158 km/h)
- R** up to 106 mph (170 km/h)



|   |  |
|---|--|
| S | up to 110 mph (180 km/h)               |
| T | up to 118 mph (190 km/h)               |
| U | up to 124 mph (200 km/h)               |
| H | up to 130 mph (210 km/h)               |
| V | up to 149 mph (240 km/h) <sup>1)</sup> |
| Z | over 149 mph (240 km/h) <sup>1)</sup>  |
| W | up to 168 mph (270 km/h) <sup>1)</sup> |
| Y | up to 186 mph (298 km/h) <sup>1)</sup> |

Your vehicle is normally factory equipped with tires, which possess excellent driving characteristics and give your Audi optimum driving comfort. An electronic speed limiter ⇒ *page 28* will normally prevent your vehicle from going faster than the tire speed rating ⇒ .

### U.S. DOT Tire Identification Number (TIN) and tire manufacture date

This is the tire's "serial number". It begins with the letters "DOT" and indicates that the tire meets all federal standards. The next two numbers or letters indicate the plant where it was manufactured, and the last four numbers represent the week and year of manufacture. For example, the numbers 2212 mean that the tire was produced in the 22nd week of 2012. The other numbers are marketing codes that may or may not be used by the tire manufacturer. This information is used to contact consumers if a tire defect requires a recall.

### Audi Original tire

Tires with the identification "AO" or "RO" have been specially matched with your Audi. We recommend using only these tires because they meet the highest standards regarding safety and driving characteristics when used correctly. Your authorized Audi dealer will gladly provide you with more information.

### Tire ply composition and materials used

The number of plies indicates the number of layers of rubber-coated fabric in the tire. In

general, the greater the number of plies, the more weight a tire can support. Tire manufacturers also must indicate the materials in the tire, which include steel, nylon, polyester, and others.

### Maximum Load Rating

This number indicates the maximum load in kilograms and pounds that can be carried by the tire.

### Tire quality grading for treadwear, traction, and temperature resistance

Tread wear, traction and temperature grades ⇒ *page 294*.

### Maximum Permissible Inflation Pressure

This number is the greatest amount of air pressure that should ever be put in the tire under normal driving conditions.



### WARNING

- Using incorrect or unmatched tires and / or wheels or improper tire and wheel combinations can lead to loss of control, collision and serious personal injury.
- Always use tires, rims and wheel bolts that meet the specifications of original factory-installed tires or other combinations that have been specifically approved by the vehicle manufacturer.
- Tires age even if they are not being used and can fail suddenly, especially at high speeds. Tires that are more than 6 years old can only be used in an emergency and then with special care and at lower speeds.
- Never mount used tires on your vehicle if you are not sure of their "previous history." Old used tires may have been damaged even though the damage cannot be seen that can lead to sudden tire failure and loss of vehicle control.

<sup>1)</sup> For tires with a maximum speed capability over 149 mph (240 km/h), tire manufacturers sometimes use the letters "ZR."

- All four wheels must be fitted with radial tires of the same type, size (rolling circumference) and the same tread pattern. Driving with different tires reduces vehicle handling and can lead to a loss of control.
- If the spare tire is not the same as the tires that are mounted on the vehicle - for example with winter tires - only use the spare tire for a short period of time and drive with extra care. Refit the normal road wheel as soon as safely possible.
- Never drive faster than the maximum speed for which the tires on your vehicle are rated because tires that are driven faster than their rated speed can fail suddenly.
- Overloading tires cause heat build-up, sudden tire failure, including a blowout and sudden deflation and loss of control.
- Temperature grades apply to tires that are properly inflated and not over or underinflated.
- For technical reasons it is not always possible to use wheels from other vehicles - in some cases not even wheels from the same vehicle model.
- If you install wheel trim discs on the vehicle wheels, make sure that the air flow to the brakes is not blocked. Reduced air-flow to the brakes can lead to overheating, increasing stopping distances and causing a collision.
- Run flat tires may only be used on vehicles that were equipped with them at the factory. The vehicle must have a chassis designed for run flat tires. Incorrect use of run flat tires can lead to vehicle damage or accidents. Check with an authorized Audi dealer or tire specialist to see if your vehicle can be equipped with run flat tires. If run flat tires are used, they must be installed on all four wheels. Mixing tire types is not permitted.

### Note

- For technical reasons, it is not generally possible to use the wheel rims from other vehicles. This can hold true for wheels of the same vehicle type.
- If the spare tire is different from the tires that you have mounted on your vehicle (for example winter tires or wide profile tires), then use the spare tire for a short period of time only and drive with extra care. Replace the flat tire with the tire matching the others on your vehicle as soon as possible.
- Never drive without the valve stem cap. The valves could get damaged.

### For the sake of the environment

Dispose of old tires in accordance with the local requirements.

## Uniform tire quality grading

- Tread wear
- Traction AA A B C
- Temperature A B C

Quality grades can be found where applicable on the tire side wall between tread shoulder and maximum section width ⇒ *page 291, fig. 255.*

**For example:** Tread wear **200**, Traction **AA**, Temperature **A**.

All passenger car tires must conform to Federal Safety Requirements in addition to these grades.

### Tread wear

The *tread wear* grade is a comparative rating based on the wear rate of the tire when tested under controlled conditions on a specified government test course.

For example, a tire graded 150 would wear one and one half (1 1/2) times as well on the government course as a tire graded 100. ▶

The relative performance of tires depends upon the actual conditions of their use, however, and may depart significantly from the norm due to variations in driving habits, service practices and differences in road characteristics and climate.

### Traction

The *traction* grades, from highest to lowest, are AA, A, B and C. Those grades represent the tire's ability to stop on wet pavement as measured under controlled conditions on specified government test surfaces of asphalt and concrete. A tire marked C may have poor traction performance ⇒ ⚠.

### Temperature

The *temperature* grades are A (the highest), B, and C, representing the tire's resistance to the generation of heat and its ability to dissipate heat when tested under controlled conditions on a specified indoor laboratory test wheel.

Sustained high temperature can cause the material of the tire to degenerate and reduce tire life, and excessive temperature can lead to sudden tire failure ⇒ ⚠.

The grade C corresponds to a level of performance which all passenger car tires must meet under the Federal Motor Vehicle Safety Standard No. 109. Grades B and A represent higher levels of performance on the laboratory test wheel than the minimum required by law.

#### WARNING

The traction grade assigned to this tire is based on straight-ahead braking traction tests, and does not include acceleration, cornering, hydroplaning or peak traction characteristics.

#### WARNING

The temperature grade for this tire is established for a tire that is properly inflated and not overloaded. Excessive speed, underinflation, or excessive loading, either

separately or in combination, can cause heat buildup and possible tire failure.

### Winter tires

*Winter tires can improve vehicle handling on snow and ice. At temperatures below 45 °F (7 °C) we recommend changing to winter tires.*

In some heavy snow areas, local governments may require true winter or “snow” tires, those with very deeply cut tread. These tires should only be used in pairs and be installed on all four wheels. Make sure you purchase snow tires that are the same size and construction type as the other tires on your vehicle.

Your vehicle is equipped with all-wheel drive, this will improve traction during winter driving, even with the standard tires. However, we strongly recommend that you always equip all four wheels on your vehicle with correctly fitted winter tires or all-season tires, when winter road conditions are expected. This also improves the vehicle's braking performance and reduces stopping distances.

Summer tires provide less grip on ice and snow.

Winter tires (snow tires) must always be fitted on all four wheels.

Ask your authorized Audi dealer or qualified workshop for permitted **winter tire sizes**. Use only radial winter tires.

Winter tires lose their effectiveness when the tread is worn down to a depth of 0.157 inch (4 mm).

Only drive with winter tires under winter conditions. Summer tires handle better when there is no snow or ice on the roads and the temperature is above 45 °F (7 °C).

If you have a flat tire, see notes on spare wheel ⇒ *page 291*.

Please always remember that winter tires may have a lower speed rating than the tires originally installed on your vehicle at the time it

was manufactured. Please see ⇒ *page 292*, *Speed rating (letter code)* for a listing of the speed rating letter codes and the maximum speed at which the tires can be driven.

The speed rating letter code (⇒ *page 282*) is on the side wall of the tire ⇒ *page 291*.

### WARNING

Winter tires have maximum speed limits that may be lower than your vehicle's maximum speed. Always know the maximum speed before driving off. Never drive faster than the speed permitted for your specific winter tires. This will cause damage to the tires leading to an accident and serious personal injury to you and your passengers.

### WARNING

Driving faster than the maximum speed for which the winter tires on your vehicle were designed can cause tire failure including a blowout and sudden deflation, loss of control, crashes and serious personal injuries. Have worn or damaged tires replaced immediately.

- Winter tires have maximum speed rating that may be lower than your vehicle's maximum speed.
- Never drive faster than the speed for which the winter or other tires installed on your vehicle are rated.

### WARNING

Always adjust your driving to the road and traffic conditions. Never let the good acceleration of the winter tires and all-wheel drive tempt you into taking extra risks. Always remember:

- When braking, an all-wheel drive vehicle handles in the same way as a front drive vehicle.
- Drive carefully and reduce your speed on icy and slippery roads, even winter tires cannot help under black ice conditions.



### For the sake of the environment

Use summer tires when weather conditions permit. They are quieter, do not wear as quickly and reduce fuel consumption.

## Snow chains

Snow chains may be fitted only to the rear wheels, and only to certain tire sizes. Ask your authorized Audi dealer on which tire sizes snow chains can be used.

The snow chains must have low-profile links and must not be thicker than 0.53 inch (13.5 mm), including the lock.

Remove wheel center covers and trim discs before putting snow chains on your vehicle ⇒ . For safety reasons cover caps must then be fitted over the wheel bolts. These are available from authorized Audi dealers.



### WARNING

Using the wrong snow chains for your vehicle or installing them incorrectly can increase the risk of loss of control leading to serious personal injury.

- Snow chains are available in different sizes. Always make sure to follow the instructions provided by the snow chain manufacturer.
- When driving with snow chains never drive faster than the speed permitted for your specific snow chains.
- Always observe local regulations.



### Note

- Remove snow chains before driving on roads not covered with snow to avoid damaging tires and wearing the snow chains down unnecessarily.
- Snow chains, which come into direct contact with the wheel rim, can scratch or damage it. Therefore, make sure that the snow chains are suitably covered. Check the position of the snow chains after

- driving a few yards and correct if necessary. Follow the instructions from the snow chain manufacturer when doing so.
- If the Adaptive Air Suspension\* should malfunction, do not mount or use snow chains because the vehicle will be extremely low. If you do drive with snow chains on while the vehicle is at this level, the snow chains might severely damage the wheelhouse and other parts of the vehicle.

### Tips

Where snow chains are mandatory on certain roads, this normally also applies to vehicles with all-wheel drive.

## Wheel bolts

*Wheel bolts must always be tightened to the correct torque.*

The design of wheel bolts is matched to the factory installed rims. If different rims are fitted, the correct wheel bolts with the right length and correctly shaped bolt heads must be used. This ensures that wheels are fitted securely and that the brake system functions correctly.

In certain circumstances, you may not use wheel bolts from a different vehicle – even if it is the same model ⇒ *page 327*.

### WARNING

Improperly tightened or maintained wheel bolts can become loose causing loss of control, a collision and serious personal injury.

- Always keep the wheel bolts and the threads in the wheel hubs clean so the wheel bolts can turn easily and be properly tightened.
- Never grease or oil the wheel bolts and the threads in the wheel hubs. They can become loose while driving if greased or oiled, even if tightened to the specified torque.

- Only use wheel bolts that belong to the rim being installed.
- Never use different wheel bolts on your vehicle.
- Always maintain the correct tightening torque for the wheel bolts to reduce the risk of a wheel loss. If the tightening torque of the wheel bolts is too low, they can loosen and come out when the vehicle is moving. If the tightening torque is too high, the wheel bolts and threads can be damaged and the wheel can become loose.

### Note

The specified torque for the wheel bolts is 120 ft lb (160 Nm) with a tolerance of  $\pm 7,4$  ft lb ( $\pm 10$  Nm). Torque wheel bolts diagonally. After changing a wheel, the torque must be checked as soon as possible with a torque wrench – preferably by an authorized Audi dealer or qualified workshop.

## Low aspect ratio tires

Your Audi is factory-equipped with low aspect ratio tires. These tires have been thoroughly tested and been selected specifically for your model for their superb performance, road feel and handling under a variety of driving conditions. Ask your authorized Audi dealer for more details.

The low aspect ratio of these tires is indicated by a numeral of **55 or less** in the tire's size designation. The numeral represents the ratio of the tire's sidewall height in relation to its tread width expressed in percentage. Conventional tires have a height/width ratio of 60 or more.

**The performance of low-aspect-ratio tires is particularly sensitive to improper inflation pressure. It is therefore important that low aspect ratio tires are inflated to the specified pressure and that the inflation pressure is regularly checked and maintained. Tire pressures should be checked at least once a**

**month and always before a long trip**

⇒ *page 286, Checking tire pressure.*

**What you can do to avoid tire and rim damage**

Low aspect ratio tires can be damaged more easily by impact with potholes, curbs, gullies or ridges on the road, particularly if the tire is underinflated.

In order to minimize the occurrence of impact damage to the tires of your vehicle, we recommend that you observe the following precautions:

- Always maintain recommended inflation pressures. Check your tire pressure every 2,000 miles (3,000 km) and add air if necessary.
- Drive carefully on roads with potholes, deep gullies or ridges. The impact from driving through or over such obstacles can damage your tires. Impact with a curb may also cause damage to your tires.
- After any impact, immediately inspect your tires or have them inspected by the nearest authorized Audi dealer. Replace a damaged tire as soon as possible.
- Inspect your tires every 2,000 miles (3,000 km) for damage and wear. Damage is not always easy to see. Damage can lead to loss of air and underinflation, which could eventually cause tire failure. If you believe that a tire may have been damaged, replace the tire as soon as possible.
- These tires may wear more quickly than others.
- Please also remember that, while these tires deliver responsive handling, they may ride less comfortably and make more noise than other choices.

**Reduced performance in winter/cold season conditions**

All tires are designed for certain purposes. The low aspect ratio, ultra high performance tires originally installed on your vehicle are intended for maximum dry and wet road performance and handling. They are not suitable for cold, snowy or icy weather conditions. If

you drive under those circumstances, you should equip your vehicle with all-season or winter tires, which offer better traction under those conditions. We suggest you use the recommended snow or all-season tires specified for your vehicle, or their equivalent.

Refer to ⇒ *page 295* for more detailed information regarding winter tires.

**Tire pressure monitoring system****(!) General notes**

Each tire, including the spare (if provided), should be checked monthly when cold and inflated to the inflation pressure recommended by the vehicle manufacturer on the vehicle placard or tire inflation pressure label. (If your vehicle has tires of a different size than the size indicated on the vehicle placard or tire inflation pressure label, you should determine the proper tire inflation pressure for those tires).

As an added safety feature, your vehicle has been equipped with a tire pressure monitoring system (TPMS) that illuminates a low tire pressure telltale when one or more of your tires is significantly under-inflated. Accordingly, when the low tire pressure telltale illuminates, you should stop and check your tires as soon as possible, and inflate them to the proper pressure. Driving on a significantly under-inflated tire causes the tire to overheat and can lead to tire failure. Under-inflation also reduces fuel efficiency and tire tread life, and may affect the vehicle's handling and stopping ability.

Please note that the TPMS is not a substitute for proper tire maintenance, and it is the driver's responsibility to maintain correct tire pressure, even if under-inflation has not reached the level to trigger illumination of the TPMS low tire pressure telltale.

Your vehicle has also been equipped with a TPMS malfunction indicator to indicate when the system is not operating properly. The

TPMS malfunction indicator is combined with the low tire pressure telltale. When the system detects a malfunction, the telltale will flash for approximately one minute and then remain continuously illuminated. This sequence will continue upon subsequent vehicle start-ups as long as the malfunction exists.

When the malfunction indicator is illuminated, the system may not be able to detect or signal low tire pressure as intended. TPMS malfunctions may occur for a variety of reasons, including the installation of replacement or alternate tires or wheels on the vehicle that prevent the TPMS from functioning properly. Always check the TPMS malfunction telltale after replacing one or more tires or wheels on your vehicle to ensure that the replacement or alternate tires and wheels allow the TPMS to continue to function properly.

### Tire pressure indicator appears

The tire pressure indicator in the instrument cluster informs you if the tire pressure is too low or if there is a system malfunction.

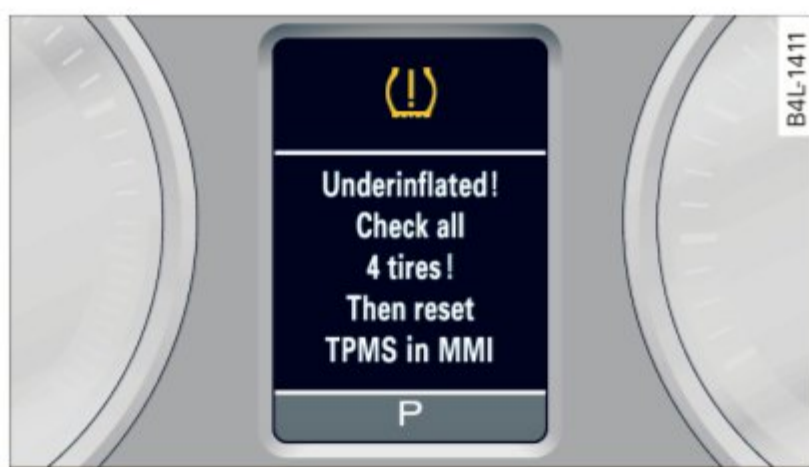



Fig. 256 Display: underinflation warning



Using the ABS sensors, the tire pressure monitoring system compares the tire tread circumference and vibration characteristics of the individual tires. If the pressure decreases in one or more tires, this is indicated in the instrument cluster with a  warning symbol and a message  $\Rightarrow$  fig. 256. The driver message in the display goes out after 5 seconds. The driver message can be displayed again by pressing the **CHECK** button. If only one tire is affected, the display will indicate its position.

The tire pressure monitoring must be reset via MMI each time the pressures are adjusted (e. g. when switching between partial and full load pressure) or after changing or replacing a tire on your vehicle  $\Rightarrow$  page 300. The TPMS indicator only monitors the tire pressure that you have previously stored. You can find the recommended tire pressures for your vehicle on the label on driver's side B-pillar  $\Rightarrow$  page 284.

Tire tread circumference and vibration characteristics can change and cause a tire pressure warning if:

- the tire pressure in one or more tires is too low,
- the tire has structural damage,
- the tire pressure was changed, wheels rotated or replaced but the TPMS was not reset  $\Rightarrow$  page 300.

### Warning symbols

 Loss of pressure in at least one tire  $\Rightarrow$  . Check the tire or tires and replace or repair if necessary. The  indicator light in the instrument cluster also illuminates  $\Rightarrow$  page 14. Check/correct the pressures of all four tires and reset TPMS via MMI.

**TPMS** (Tire Pressure Monitoring System) **Tire pressure: System malfunction!**

If **TPMS** appears after switching the ignition on or while driving and the  indicator light in the instrument cluster blinks for approximately one minute and then stays on, there is a system malfunction.

Attempt to store the correct tire pressure  $\Rightarrow$  page 300. If the indicator light does not turn off or if it turns on shortly thereafter, immediately drive your vehicle to an authorized Audi dealer or authorized repair facility to have the malfunction corrected.

### WARNING

- If the tire pressure indicator appears in the instrument cluster display, one or more of your tires is significantly underinflated. Reduce your speed immediately 

and avoid any hard steering or braking maneuvers. Stop as soon as possible and check the tires and their pressures. Inflate the tire pressure to the proper pressure as indicated on the vehicle's tire pressure label ⇒ *page 284*. Driving on a significantly under-inflated tire causes the tire to overheat and can lead to tire failure. Under-inflation also is likely to impair the vehicle's handling and stopping ability.

- The driver is responsible for maintaining the correct tire pressures. You must check the tire pressures regularly.
- Under certain conditions (such as a sporty driving style, winter conditions or unpaved roads), the pressure monitor indicator may be delayed.
- Ask your authorized Audi dealer if run-flat tires may be used on your vehicle. Your vehicle registration becomes invalid if you use these tires when not permitted. Damage to your vehicle or accidents could also result.

### Tips

- The tire pressure monitoring system stops working when there is an ESC/ABS malfunction.
- Using snow chains may result in a system malfunction.
- The tire pressure monitoring system on your Audi was developed using tires with the “AO” or “RO” identification on the tire sidewall ⇒ *page 291*. We recommend using these tires.

### Reset tire pressure monitoring system

*If the tire pressure is adjusted, wheels are rotated or changed, the TPMS must be reset via MMI.*

- ▶ Before resetting the TPMS, the current pressures of all four tires must correspond to the specified values. Adjust the tire pressure and reset the pressure in the tire pressure

monitoring system according to the load you are carrying ⇒ *page 284*.

- ▶ Turn on the ignition.
- ▶ Select: **CAR** function button > **Systems\*** control button > **Tire pressure monitoring** > **Store now**. Or
- ▶ Select: **CAR** function button > **Car systems\*** control button > **Servicing & checks** > **Tire pressure monitoring** > **Store tire pressures**.

### Tips

Do not store the tire pressure if there are snow chains on the tire.

## What do I do now?

### Jack, tools and inflatable spare tire

#### Tools

The tool kit is located in the luggage compartment under the cargo floor cover.

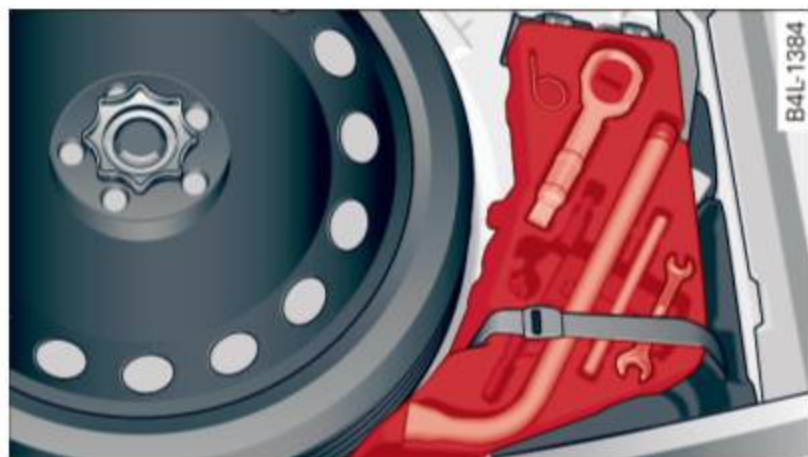

Fig. 257 Luggage compartment: vehicle tool kit

The onboard tool kit includes:

- Hook for removing wheel covers\*
- Plastic hook to remove wheel bolt covers\*
- Wheel bolt wrench
- Alignment pin for changing wheels
- Screwdriver with reversible blade
- 10 x 13 open ended wrench
- Towing eye

#### **i** Tips

Some of the onboard items listed above are provided on certain models only or are optional extras.

#### Jack and folding chocks

The jack and the folding chocks are located in the luggage compartment under the cargo floor cover.

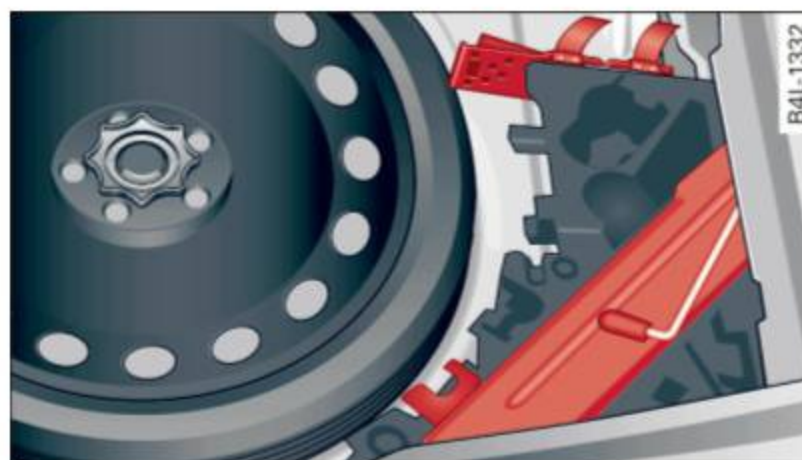

Fig. 258 Luggage compartment vehicle jack and folding chocks

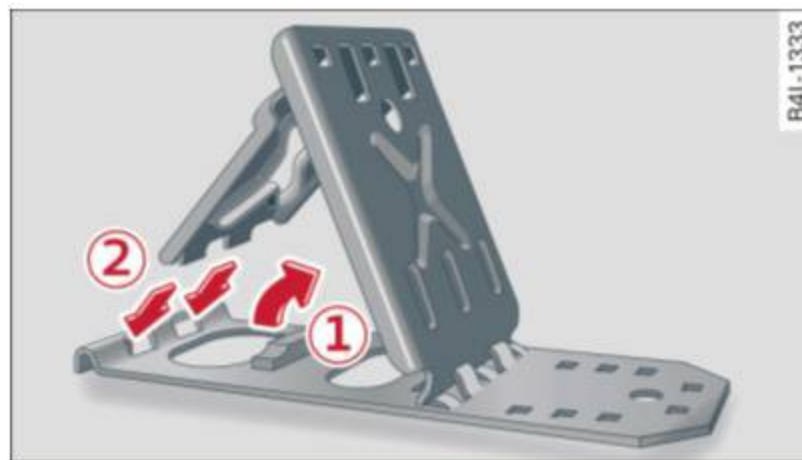

Fig. 259 Opening folding chocks

#### Vehicle jack

The jack is located under the tool kit ⇒ fig. 258. Before storing the jack, make sure it is wound back down as far as it will go.

#### Folding chocks

Two unassembled folding chocks are attached to the foam section at the front with the jack ⇒ fig. 258.

Release the two hook-and-loop fasteners, and remove the two chocks. To use the chocks, you first have to raise the support plate ⇒ fig. 259 ① and then insert the locking plate with the two “tabs” into the elongated holes in the base plate ② ⇒ ⚠.

#### **!** WARNING

- The chock cannot fulfill its function and may lose its stability if the “tabs” on the support plate are not inserted correctly into the elongated holes in the base

plate. If this happens, the vehicle may start to move while a wheel is being changed.

- Never use the folding chocks if they are damaged or if they have not been assembled correctly.

### WARNING

Improper use of the vehicle jack can cause serious personal injuries.

- Never use the jack supplied with your Audi on another vehicle, particularly on a heavier one. The jack is only suitable for use on the vehicle it came with.
- Using a bumper jack to raise the vehicle will damage the bumper system. The jack may slip, causing injury.
- Never support your vehicle on cinder blocks, bricks or other objects. These may not be able to support the load and could cause injury when they fail.
- Never start or run the engine while the vehicle is supported by the jack.
- If you must work under the vehicle, always use safety stands specifically designed for this purpose.
- Always make sure the inflatable spare tire and even a flat tire are secured in place and not loose, otherwise they could fly forward, causing personal injury to passengers in the vehicle in an accident or sudden maneuver.

### Removing bass box

Applies to vehicles: with bass box

*Before the inflatable spare tire can be taken out, the bass box must be removed.*

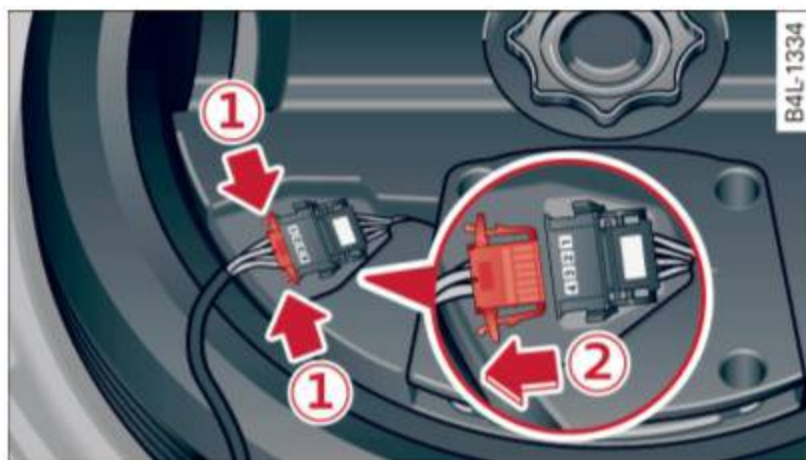

Fig. 260 Spare wheel well: Bass box

### Removing bass box

- ▶ Squeeze the locking tabs ⇒ *fig. 260* ① of the connector.
- ▶ Disconnect the connector ② and place the lead to one side.
- ▶ Turn the large screw counter-clockwise.
- ▶ Carefully remove the bass box.

### Installing bass box

- ▶ Carefully place the bass box in the wheel. The inscription “FRONT” on the bass box must face forward.
- ▶ Reconnect the connector that was removed.
- ▶ Secure the bass box with the large screw.

### Inflatable spare tire

*The inflatable spare tire expands to its full diameter when it is inflated.*



Fig. 261 Inflatable spare tire with compressor

### Removing inflatable spare tire

- ▶ Lift up the cargo floor using the handle.
- ▶ Turn the large screw ⇒ *fig. 261* counter-clockwise.
- ▶ Remove the bass box as required ⇒ *page 302*.
- ▶ Take out the inflatable spare tire.
- ▶ Always store the vehicle tool kit, the jack and the replaced tire in the luggage compartment ⇒ *page 171*.

### Stowing the inflatable spare tire

- ▶ Release the air by unscrewing the valve stem.
- ▶ Screw the valve stem back in afterwards.
- ▶ Wait a few hours before placing the wheel in the spare wheel well ⇒ .
- ▶ Install the bass box as required ⇒ *page 302*. ▶

- ▶ Secure the wheel with the large screw.
- ▶ Fold the cargo floor back down.

### After using the inflatable spare wheel

The inflatable spare tire can be re-used as long as it is not damaged and is not worn down to the tread wear indicators ⇒ .

When you let the air out of the inflatable spare tire, it does not assume its folded shape again for several hours. Until then, it cannot be placed back in the spare wheel well and stowed securely.

#### WARNING

- Never use the spare tire if it is damaged or if it is worn down to the tread wear indicators.
- If the inflatable spare tire is more than 6 years old, use it only in an emergency and with extreme caution and careful driving.
- The inflatable spare tire is intended only for temporary and short-term use. It should be replaced as soon as possible with the normal wheel and tire.
- The tire pressure value for the inflatable spare tire is located on the driver's side B-pillar ⇒ *page 284, fig. 252*.
- Maximum permissible speed is 50 mph (80 km/h).
- Avoid full-throttle acceleration, heavy braking, and fast cornering.
- When the air is let out of the inflatable spare wheel, it does not assume its folded shape for several hours. Until then, it cannot be placed back in the spare wheel well and stowed securely.
- Never drive with more than one inflatable spare tire.
- For technical reasons, the use of tire chains on the inflatable spare tire is not permitted. If it is necessary to drive with tire chains, the inflatable spare wheel must be mounted on the front axle in the event of a flat in a rear tire. The newly available front wheel must then be installed in place of the rear wheel with

the flat tire. Installing the tire chain before mounting the wheel and tire is recommended.

- Loose items in the passenger compartment can cause serious personal injury during hard braking or in an accident. Never store the inflatable spare tire or jack and tools in the passenger compartment.

#### Note

- The inflatable spare tire has been developed specifically for this vehicle model. It must not be exchanged or used for other vehicle models. Similarly, inflatable tires from other vehicle models must not be used.
- Normal summer or winter tires must not be installed on the inflatable tire rim.

### Inflating inflatable spare tire

- ▶ Remove the compressor from the luggage compartment ⇒ *page 302, fig. 261*.
- ▶ Unscrew the valve stem from the spare tire.
- ▶ Screw the tire filler hose from the compressor firmly onto the valve of the spare tire.
- ▶ Insert the plug from the compressor into an outlet of the vehicle ⇒ *page 87*.
- ▶ Switch the compressor on.
- ▶ Let the compressor run until the value specified on the tire pressure label is reached ⇒ *page 284, fig. 252*. Switch the compressor off after running for 12 minutes at the most - danger of overheating!

#### WARNING

The compressor and the tire filler hose can become extremely hot while they are running - danger of burns!





#### Note

Switch the compressor off after running for 12 minutes at the most - danger of overheating! Allow the compressor to cool down for a few minutes before you use it again.

## Changing a wheel

### Before changing a wheel

Observe the following precautions for your own and your passenger's safety when changing a wheel.

- ▶ After you experience a tire failure, pull the car well away from moving traffic and try to reach **level** ground before you stop ⇒ .
- ▶ All passengers should **leave the car** and move to a safe location (for instance, behind the guardrail) ⇒ .
- ▶ Engage the **parking brake** to prevent your vehicle from rolling unintentionally ⇒ .
- ▶ Move **selector lever to position P** ⇒ .
- ▶ If you are towing a trailer: unhitch the trailer from your vehicle.
- ▶ Block the diagonally opposite wheel with the folding chocks or other objects.
- ▶ Take the **jack** and the **inflatable spare tire** out of the luggage compartment ⇒ *page 301*.

### WARNING

You or your passengers could be injured while changing a wheel if you do not follow these safety precautions:

- If you have a flat tire, move a safe distance off the road. Turn off the engine, turn the emergency flashers on and use other warning devices to alert other motorists.
- Make sure that passengers wait in a safe place away from the vehicle and well away from the road and traffic.
- To help prevent the vehicle from moving suddenly and possibly slipping off the jack, always fully set the parking brake and block the wheel diagonally opposite the wheel being changed with the folding chocks or other objects. When one front wheel is lifted off the ground, placing the Automatic Transmission in “P” (Park) will *not* prevent the vehicle from moving.

- Before you change a wheel, be sure the ground is level and firm. If necessary, use a sturdy board under the jack.
- After installing the inflatable spare tire, make sure that you replace the flat tire/wheel in its storage area properly and tighten the knurled retaining screw securely.

### Changing a wheel

When you change a wheel, follow the sequence described below step-by-step and in exactly that order.

1. Activate the vehicle jack mode (only vehicles with Adaptive Air Suspension) ⇒ *page 159*.
2. Remove the **decorative wheel cover\***. For more details see also ⇒ *page 305, Decorative wheel covers* or ⇒ *page 305, Wheels with wheel bolt caps*.
3. Loosen the **wheel bolts** ⇒ *page 305*.
4. Locate the proper mounting point for the jack and align the jack below that point ⇒ *page 306*.
5. **Lift** the car with the jack ⇒ *page 306*.
6. Remove the **wheel with the flat tire** and then install the **inflatable spare tire** ⇒ *page 307*.
7. Tighten all wheel bolts lightly.
8. **Lower** the vehicle with the jack.
9. Use the wheel bolt wrench and **firmly** tighten all wheel bolts ⇒ *page 305*.
10. Replace the decorative **wheel cover\***.
11. Deactivate the vehicle jack mode (only vehicles with Adaptive Air Suspension) ⇒ *page 159*.

### WARNING

Always read and follow all WARNINGS and information ⇒  in *Raising the vehicle on page 307* and ⇒ *page 308*.

## After changing a wheel

A wheel change is not complete without doing the following.

- ▶ Always store the vehicle tool kit, the jack and the replaced tire in the luggage compartment ⇒ *page 171*.
- ▶ As soon as possible, have the **tightening torques** on all wheel bolts checked with a torque wrench. The correct tightening torque is 120 ft lb (160 Nm).
- ▶ Have the flat tire **replaced** as soon as possible.

### **i** Tips

- If you notice that the wheel bolts are corroded and difficult to turn while changing a tire, they should be replaced before you check the tightening torque.
- Drive at reduced speed until you have the tightening torques checked.

## Decorative wheel covers

Applies to vehicles: with decorative wheel covers

The decorative wheel covers must be removed first to access the wheel bolts.



Fig. 262 Changing a wheel: Removing the wheel cover

### Removing

- ▶ Insert the **hook** provided with the vehicle tool kit in the hole in the hub.
- ▶ Pull off the **decorative wheel cover** ⇒ *fig. 262*.

## Wheels with wheel bolt caps

Applies to vehicles: with wheel bolts with caps

The caps must be removed first from the wheel bolts before the bolts can be unscrewed.



Fig. 263 Changing a wheel: removing the wheel bolt caps

### Removing

- ▶ Push the **plastic clip** provided with the vehicle tool kit over the wheel bolt cap until it engages.
- ▶ Pull on the **plastic clip** to remove the cap ⇒ *fig. 263*.

### Refitting

- ▶ Place the caps over the wheel bolts and push them back on.

The caps are to protect and keep the wheel bolts clean.

## Loosening and tightening the wheel bolts

The wheel bolts must be loosened before raising the vehicle.



Fig. 264 Changing a wheel: loosening the wheel bolts

### Loosening

- ▶ Install the **wheel bolt wrench** over the wheel bolt and push it down as far as it will go.
- ▶ Take tight hold of the *end* of the wrench handle and turn the wheel bolts **counter-clockwise** about *one single* turn in the direction of arrow ⇒ *fig. 264*.

### Tightening

- ▶ Install the **wheel bolt wrench** over the wheel bolt and push it down as far as it will go.
- ▶ Take tight hold of the *end* of the wrench handle and turn each wheel bolt **clockwise** until it is seated.

#### **WARNING**

- Do not use force or hurry when changing a wheel - you can cause the vehicle to slip off the jack and cause serious personal injuries.
- *Do not* loosen the wheel bolts *more than one turn* before you raise the vehicle with the jack. - You risk an injury.

#### **Tips**

If a wheel bolt is very tight, you may find it easier to loosen by carefully pushing down on the end of the wheel bolt wrench with *one foot only*. As you do so, hold on to the car to keep your balance and take care not to slip.

### Raising the vehicle

*The vehicle must be lifted with the jack first before the wheel can be removed.*

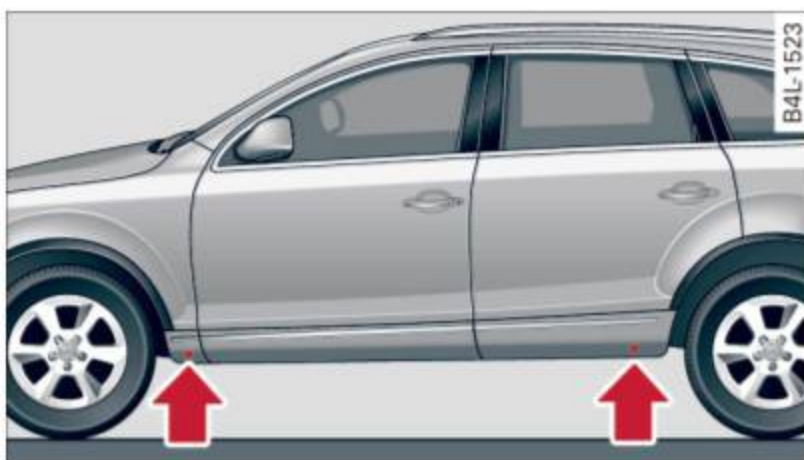

Fig. 265 Sill panels: markings

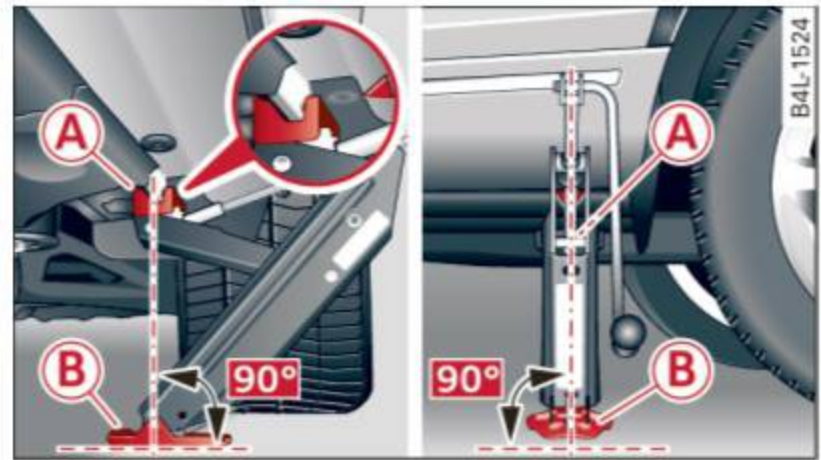







Fig. 266 Sill: positioning the jack

- ▶ Activate the vehicle jack mode\* (only vehicles with Adaptive Air Suspension) ⇒ *page 159*.
- ▶ Engage the **parking brake** to prevent your vehicle from rolling unintentionally
- ▶ Move the **selector lever to position P**.
- ▶ Find the **marking** (imprint) on the sill that is nearest the wheel that will be changed ⇒ *fig. 265*. Behind the marking, there is a **lifting point** on the sill for the jack.
- ▶ Turn the **jack** located under the lifting point on the sill to raise the jack until its arm **A** ⇒ *fig. 266* is located under the designated plastic mount ⇒  ⇒ .
- ▶ Align the jack so that its arm **A** ⇒ *fig. 266* engages in the designated lifting point in the door sill and the movable base **B** lies flat on the ground. The base **B** must be *vertical* under the lifting point **A**.
- ▶ Wind the jack up further until the flat tire comes off the ground ⇒ .

Position the jack **only** under the designated lifting points on the sill ⇒ *fig. 265*. There is exactly *one* location for each wheel. The jack must not be positioned at any other location ⇒  ⇒ .

An **unstable surface** under the jack can cause the vehicle to slip off the jack. Always provide a firm base for the jack on the ground. If necessary place a sturdy board or similar support under the jack. On **hard, slippery surfaces** (such as tiles) use a rubber mat or similar to prevent the jack from slipping ⇒ .

**! WARNING**

- You or your passengers could be injured while changing a wheel if you do not follow these safety precautions:
  - Position the jack only at the designated lifting points and align the jack. Otherwise, the jack could slip and cause an injury if it does not have sufficient hold on the vehicle.
  - A soft or unstable surface under the jack may cause the vehicle to slip off the jack. Always provide a firm base for the jack on the ground. If necessary, use a sturdy board under the jack.
  - On hard, slippery surface (such as tiles) use a rubber mat or similar to prevent the jack from slipping.
- To help prevent injury to yourself and your passengers:
  - Do not raise the vehicle until you are sure the jack is securely engaged.
  - Passengers must not remain in the vehicle when it is jacked up.
  - Make sure that passengers wait in a safe place away from the vehicle and well away from the road and traffic.
  - Make sure jack position is correct, adjust as necessary and then continue to raise the jack.

**! Note**

Do not lift the vehicle by the sill. Position the jack only at the designated lifting points on the sill. Otherwise, your vehicle will be damaged.

**Taking the wheel off/installing the inflatable spare tire**

Follow these instructions step-by-step for changing the wheel



**Fig. 267** Changing a wheel: alignment pin inside the top hole

After you have loosened all wheel bolts and raised the vehicle off the ground, remove and replace the wheel as follows:

**Removing the wheel**

- ▶ Remove the topmost wheel bolt completely and set it aside on a *clean* surface.
- ▶ Screw the threaded end of the **alignment pin** from the tool kit hand-tight into the empty bolt hole ⇒ *fig. 267*.
- ▶ Then remove the other wheel bolts as described above.
- ▶ Take off the wheel leaving the alignment pin in the bolt hole ⇒ **!**

**Putting on the inflatable spare tire**

- ▶ Inflate the inflatable spare tire ⇒ *page 303* and push the wheel over the alignment pin.
- ▶ Screw in and tighten all wheel bolts *slightly*.
- ▶ Remove the alignment pin and insert and tighten the remaining wheel bolt slightly like the rest.
- ▶ Turn the jack handle counter-clockwise to lower the vehicle until the jack is fully released.
- ▶ Use the wheel bolt wrench to tighten all wheel bolts firmly ⇒ *page 305*. Tighten them *crosswise*, from one bolt to the (approximately) opposite one, to keep the wheel centered.

**! Note**

When removing or installing the wheel, the rim could hit the brake rotor and damage the rotor. Work carefully and have a second person help you.

**i Tips**

- When mounting tires with **unidirectional tread design** make sure the tread pattern is pointed the right way  
⇒ page 308.
- The wheel bolts should be clean and easy to turn. Check for dirt and corrosion on the mating surfaces of both the wheel and the hub. Remove all dirt from these surfaces before remounting the wheel.

**Tires with unidirectional tread design**

*Tires with unidirectional tread design must be mounted with their tread pattern pointed in the right direction.*

**Using a spare tire with a tread pattern intended for use in a specific direction**

When using a spare tire with a tread pattern intended for use in a specific direction, please note the following:

- The direction of rotation is marked by an arrow on the side of the tire.
- If the spare tire has to be installed in the incorrect direction, use the spare tire only temporarily since the tire will not be able to achieve its optimum performance characteristics with regard to aquaplaning, noise and wear.
- We recommend that you pay particular attention to this fact during wet weather and that you adjust your speed to match road conditions.
- Replace the flat tire with a new one and have it installed on your vehicle as soon as possible to restore the handling advantages of a unidirectional tire.

**Notes on wheel changing**

Please read the information ⇒ page 291, *New tires and replacing tires and wheels* if you are going to use a spare tire which is different from the tires on your vehicle.

After you change a tire:

- **Check the tire pressure on the spare immediately after installation.**
- **Have the wheel bolt tightening torque checked with a torque wrench as soon as possible by your authorized Audi dealer or a qualified workshop.**
- **With steel and alloy wheel rims, the wheel bolts are correctly tightened at a torque of 120 ft lb (160 Nm).**
- **If you notice that the wheel bolts are corroded and difficult to turn while changing a tire, they should be replaced before you check the tightening torque.**
- **Replace the flat tire with a new one and have it installed on your vehicle as soon as possible. Remount the wheel cover.**

**Until then, drive with extra care and at reduced speeds.**

**WARNING**

- If you are going to equip your vehicle with tires or rims which differ from those which were factory installed, then be sure to read the information ⇒ page 291, *New tires and replacing tires and wheels*.
- Always make sure the damaged wheel or even a flat tire and the jack and tool kit are properly secured in the luggage compartment and are not loose in the passenger compartment.
- In an accident or sudden maneuver they could fly forward, injuring anyone in the vehicle.
- Always store damaged wheel, jack and tools securely in the luggage compartment. Otherwise, in an accident or sudden maneuver they could fly forward, causing injury to passengers in the vehicle.

## Fuses and bulbs

### Electrical fuses

#### Replacing fuses

Fuses that have blown will have metal strips that have burned through.

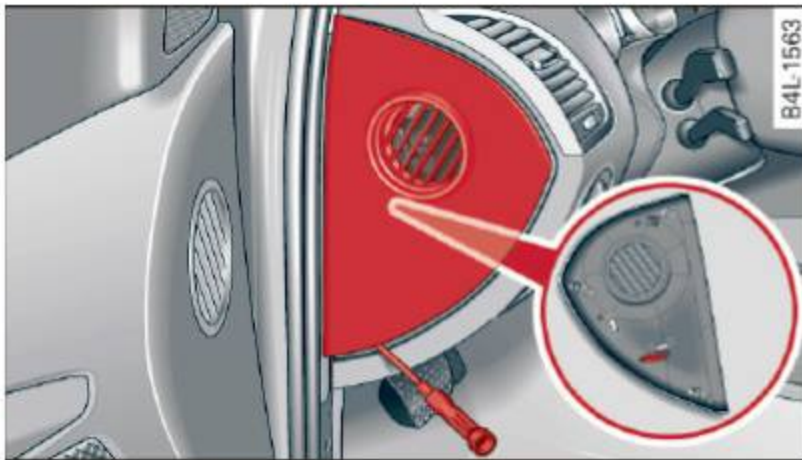

Fig. 268 Left cockpit: fuse panel cover

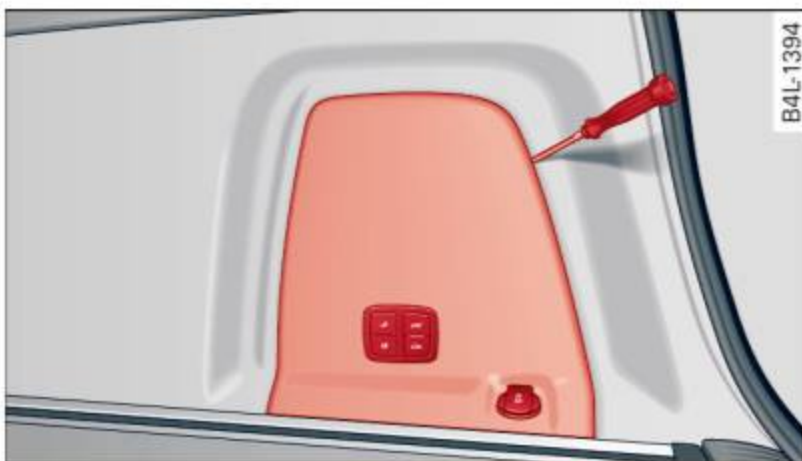

Fig. 269 Right luggage compartment: side trim

The fuses are located at the front left and right of the cockpit and behind the trim on the right side of the luggage compartment.

- ▶ Turn off the ignition and the affected electrical consumers.

- ▶ Check the following table to see which fuse belongs to the consumer.
- ▶ Remove the appropriate cover.
- ▶ To remove the purple plastic clip if necessary <sup>1)</sup>, hold onto it at the small side and pull it out of the fuse panel ⇒ page 310, fig. 270.
- ▶ Remove the clamp from the rear side of the fuse cover ⇒ fig. 268.
- ▶ Remove the fuse using the clamp and replace the blown fuse with an identical new one.

#### ⚠ WARNING

Do not repair fuses and never replace a blown fuse with one that has a higher amp rating. This can cause damage to the electrical system and a fire.

#### ! Note

If a new fuse burns out again after shortly have you have installed it, have the electrical system checked by your authorized Audi dealer.

#### i Tips

- The following table does not list fuse locations that are not used.
- Some of the equipment items listed are optional or only available on certain model configurations.

<sup>1)</sup> You can dispose of the plastic clip after removing it.

## Left cockpit fuse assignment

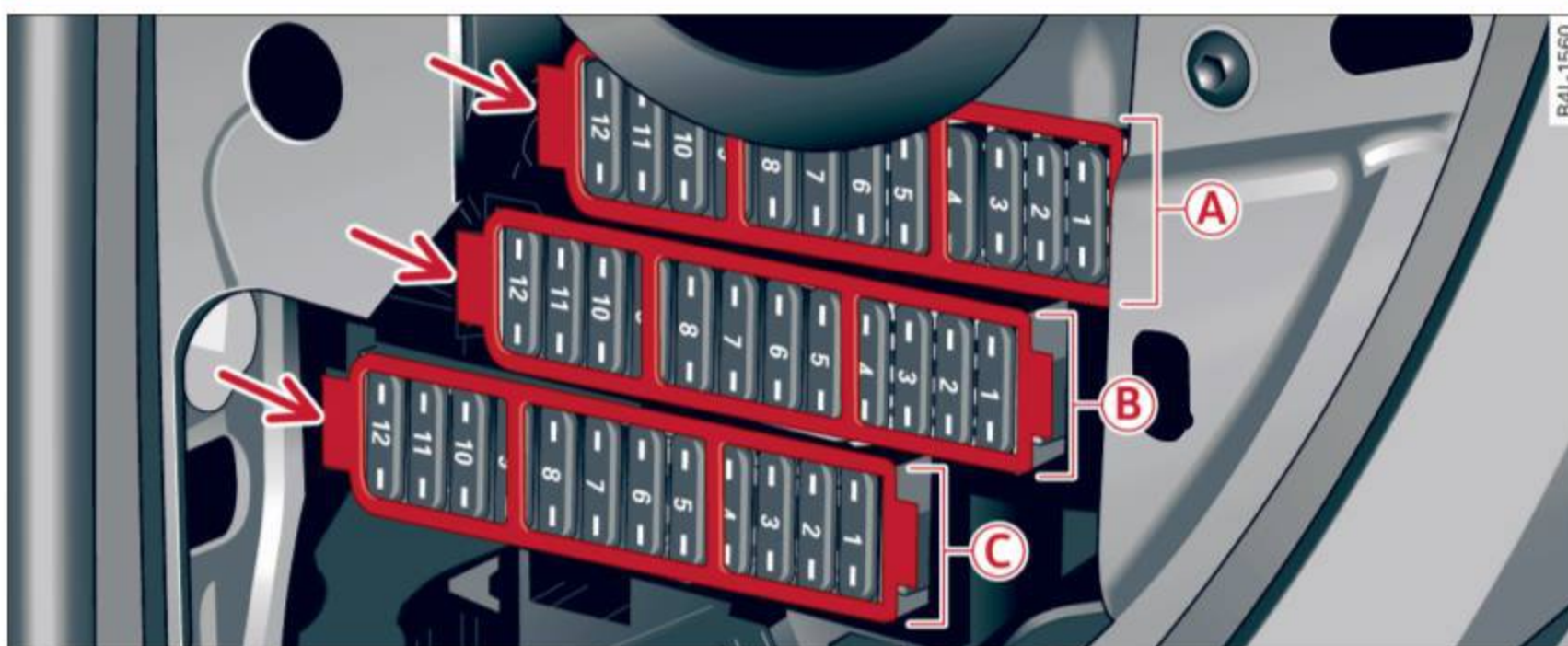

Fig. 270 Left cockpit: fuse panel with plastic clip

| No.                           | Consumer   | Amps |
|-------------------------------|--|------|
| <b>Fuse panel (A) (red)</b>   |  |      |
| 1                             | DC/DC converter  | 5    |
| 3                             | MMI  | 7,5  |
| 6                             | Lumbar support driver's seat                               | 10   |
| 7                             | Window regulators (left side of vehicle)                   | 35   |
| 8                             | Door control module (left side of vehicle)                 | 15   |
| 9                             | Tire pressure monitoring system                            | 5    |
| 10                            | Electronic ignition lock, power steering column adjustment | 30   |
| 11                            | Switch module steering column                              | 10   |
| 12                            | Intelligent power module convenience                       | 5    |
| <b>Fuse panel (B) (brown)</b> |  |      |
| 3                             | Seat ventilation (left)                                    | 15   |
| 4                             | Wiper system   | 30   |
| 5                             | Rain sensor  | 5    |
| 6                             | Horn   | 25   |
| 7                             | Intelligent power module driver                            | 30   |

| No.                           | Consumer   | Amps |
|-------------------------------|--|------|
| 8                             | Intelligent power module driver (lights left side of vehicle)  | 25   |
| 9                             | Intelligent power module driver (lights right side of vehicle) | 25   |
| 10                            | Instrument cluster   | 10   |
| 11                            | Headlight washer system  | 30   |
| 12                            | Diagnostic connector   | 10   |
| <b>Fuse panel (C) (black)</b> |  |      |
| 1                             | Headlight electronic system (left side of vehicle)             | 10   |
| 2                             | Adaptive cruise control  | 5    |
| 5                             | Rear Seat Entertainment  | 5    |
| 6                             | Terminal 15 (interior)   | 5    |
| 7                             | Oil level sensor   | 5    |
| 8                             | Diagnostic connector   | 5    |
| 9                             | Automatic dipping interior mirror                              | 5    |
| 10                            | HomeLink   | 5    |
| 11                            | Control module Gateway   | 5    |
| 12                            | Headlight range adjustment                                     | 5    |

## Right cockpit fuse assignment

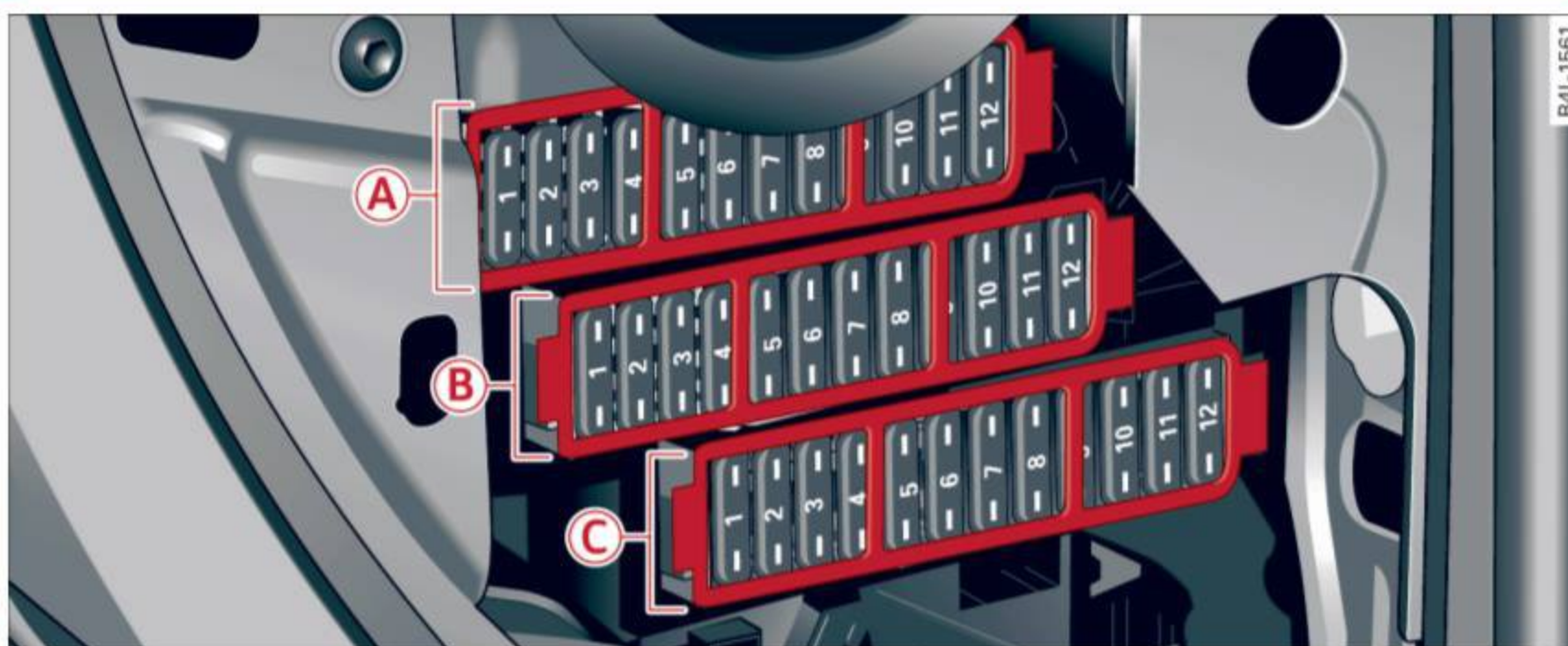

Fig. 271 Right cockpit: fuse panel with plastic clip

| No.                           | Consumer  | Amps  |
|-------------------------------|---|-------|
| <b>Fuse panel (A) (black)</b> |   |       |
| 1                             | Heated rear seats                                   | 20    |
| 2                             | Telephone, cell phone package                       | 5     |
| 3                             | Front seat heating/seat ventilation (right)         | 30/15 |
| 4                             | Electronic Stabilization Control (ESC)              | 20    |
| 5                             | Door control module (right side of vehicle)         | 15    |
| 6                             | Rear electrical outlets                             | 25    |
| 7                             | Lumbar support passenger's seat                     | 10    |
| 9                             | Front electrical outlets                            | 25    |
| 10                            | A/C controls  | 10    |
| 11                            | Cooler  | 15    |
| 12                            | Intelligent power module passenger                  | 15    |
| <b>Fuse panel (B) (brown)</b> |   |       |
| 1                             | Headlight electronic system (right side of vehicle) | 10    |
| 2                             | Ride height adjustment                              | 5     |
| 3                             | Telephone package                                   | 5     |
| 4                             | Audi side assist                                    | 5     |
| 5                             | Electronic Stabilization Control (ESC)              | 5     |

| No.                         | Consumer                                  | Amps |
|-----------------------------|---|------|
| 6                           | Automatic transmission                    | 5/20 |
| 7                           | Electronic Stabilization Control (ESC)    | 5    |
| 8                           | Shift gate automatic transmission         | 5    |
| 9                           | Parking system                            | 5    |
| 10                          | Airbag                                    | 5    |
| 11                          | Heated rear seats                         | 5    |
| 12                          | Air-conditioning                          | 5    |
| <b>Fuse panel (C) (red)</b> |   |      |
| 1                           | Instrument cluster                        | 10   |
| 2                           | Rearview camera                           | 5    |
| 3                           | CD player, DVD drive                      | 5    |
| 4                           | MMI Display                               | 5    |
| 5                           | Automatic transmission                    | 15   |
| 7                           | Panoramic sliding sunroof segment 1       | 20   |
| 8                           | Panoramic sliding sunroof segment 2       | 20   |
| 9                           | Panoramic sliding sunroof sunblind        | 20   |
| 11                          | Window regulators (right side of vehicle) | 35   |
| 12                          | Rear air-conditioning controls            | 10   |

### Right luggage compartment fuse assignment

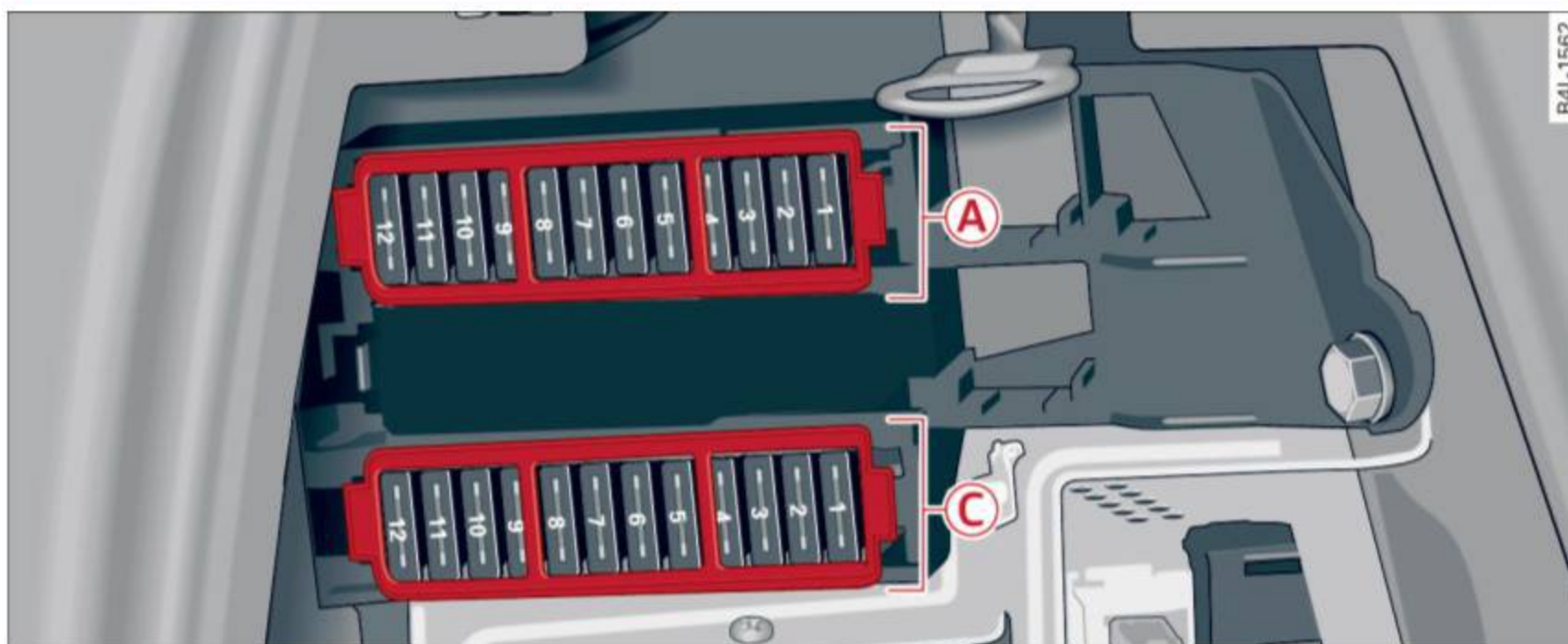

Fig. 272 Right luggage compartment: fuse panel with plastic clip

| No.                           | Consumer   | Amps   |
|-------------------------------|--|--------|
| <b>Fuse panel (A) (black)</b> |  |        |
| 1                             | Rear Seat Entertainment  | 15     |
| 2                             | AdBlue heater  | 30     |
| 3                             | Fuel filler door detection                                     | 5      |
| 5                             | Parking system   | 5      |
| 6                             | Intelligent power module convenience 2 (right side of vehicle) | 15     |
| 7                             | Intelligent power module convenience 2 (left side of vehicle)  | 15     |
| 9                             | Luggage compartment electrical outlet                          | 20     |
| 10                            | Intelligent power module convenience 1 (right side of vehicle) | 20     |
| 11                            | Convenience control module                                     | 15     |
| 12                            | Intelligent power module convenience 1 (left side of vehicle)  | 30     |
| <b>Fuse panel (C) (red)</b>   |  |        |
| 1                             | Radio  | 7,5/30 |
| 3                             | Digital Signal Processing (DSP)/BOSE amplifier                 | 30     |
| 4                             | Bang & Olufsen amplifier                                       | 30     |
| 5                             | Ride height adjustment   | 15     |

| No. | Consumer                              | Amps |
|-----|---------------------------------------|------|
| 6   | Soft close                            | 20   |
| 7   | Power rear lid                        | 30   |
| 8   | Power rear lid                        | 30   |
| 9   | Trailer hitch                         | 15   |
| 10  | Trailer hitch (left side of vehicle)  | 20   |
| 11  | Trailer hitch (right side of vehicle) | 20   |

## Bulbs

### Replacing light bulbs

*For your safety, we recommend that you have your authorized Audi dealer replace burned out bulbs for you.*

It is becoming increasingly more and more difficult to replace vehicle light bulbs since in many cases, other parts of the car must first be removed before you are able to get to the bulb. This applies especially to the light bulbs in the front of your car which you can only reach through the engine compartment.

Sheet metal and bulb holders can have sharp edges that can cause serious cuts, and parts must be correctly taken apart and then properly put back together to help prevent breakage of parts and long term damage from water that can enter housings that have not been properly resealed.

For your safety, we recommend that you have your authorized Audi dealer replace any bulbs for you, since your dealer has the proper tools, the correct bulbs and the expertise.

#### Gas discharge lamps (Xenon lights)\*:

Due to the high electrical voltage, have the bulbs replaced by a qualified technician. Headlights with Xenon light can be identified by the high voltage sticker.

#### WARNING

Contact with high-voltage components of the electrical system and improper replacement of gas discharge (Xenon) headlight bulbs can cause serious personal injury and death.

- Xenon bulbs are pressurized and can explode when being changed.
- Changing Xenon lamps requires the special training, instructions and equipment.
- Only an authorized Audi dealer or other qualified workshop should change the bulbs in gas discharge lamps.

#### WARNING

There are parts with sharp edges on the openings and on the bulb holders that can cause serious cuts.

- If you are uncertain about what to do, have the work performed by an authorized Audi dealer or other qualified workshop. Serious personal injury may result from improperly performed work.

#### Tips

- If you must replace the light bulbs yourself, always remember that the engine compartment of any vehicle is a hazardous area to work in. Always read and heed all WARNINGS ⇒ *page 255, Engine compartment* ⇒ .
- It is best to ask your authorized Audi dealer whenever you need to change a bulb.

## Emergency situations

### General

This chapter is intended for trained emergency crews and working personnel who have the necessary tools and equipment to perform these operations.

### Starting by pushing or towing

#### Note

Your vehicle is equipped with an automatic transmission. Consequently, the engine cannot be started by pushing or towing.

### Starting with jumper cables

*If necessary, the engine can be started by connecting it to the battery of another vehicle.*

If the engine should fail to start because of a discharged or weak battery, the battery can be connected to the battery of *another* vehicle, using a **pair of jumper cables** to start the engine.

#### Jumper cables

Use *only* jumper cables of sufficiently large **cross section** to carry the starter current safely. Refer to the manufacturer's specifications.

Use only jumper cables with *insulated* terminal clamps which are distinctly marked:

**plus (+) cable** in most cases colored **red**

**minus (-) cable** in most cases colored **black**.

#### WARNING

Batteries contain electricity, acid, and gas. Any of these can cause very serious or fatal injury. Follow the instructions below for safe handling of your vehicle's battery.

- Always shield your eyes and avoid leaning over the battery whenever possible.

- A discharged battery can freeze at temperatures just below 32 °F (0 °C). Before connecting a jumper cable, you must thaw the frozen battery completely, otherwise it could explode.
- Do not allow battery acid to contact eyes or skin. Flush any contacted area with water immediately.
- Improper use of a booster battery to start a vehicle may cause an explosion.
- Vehicle batteries generate explosive gases. Keep sparks, flame and lighted cigarettes away from batteries.
- Do not try to jump start any vehicle with a low acid level in the battery.
- The voltage of the booster battery must also have a 12-Volt rating. The capacity (Ah) of the booster battery should not be lower than that of the discharged battery. Use of batteries of different voltage or substantially different "Ah" rating may cause an explosion and personal injury.
- Never charge a frozen battery. Gas trapped in the ice may cause an explosion.
- Never charge or use a battery that has been frozen. The battery case may have been weakened.
- Use of batteries of different voltage or substantially different capacity (Ah) rating may cause an explosion and injury. The capacity (Ah) of the booster battery should not be lower than that of the discharged battery.
- Before you check anything in the engine compartment, always read and heed all WARNINGS ⇒ *page 255, Engine compartment*.

#### Note

- Applying a higher voltage booster battery will cause expensive damage to sensitive electronic components, such as control units, relays, radio, etc.
- There must be no electrical contact between the vehicles as otherwise current could already start to flow as soon as the positive (+) terminals are connected.

**i** Tips

- The discharged battery must be properly connected to the vehicle's electrical system. When jump starting or charging the battery, never connect the negative ground cable to the battery negative post because the battery manager system must be able to detect the battery's state of charge. Always connect the negative ground cable to the negative ground post of the battery manager control unit.

## Use of jumper cables

Make sure to connect the jumper cable clamps in exactly the order described below!

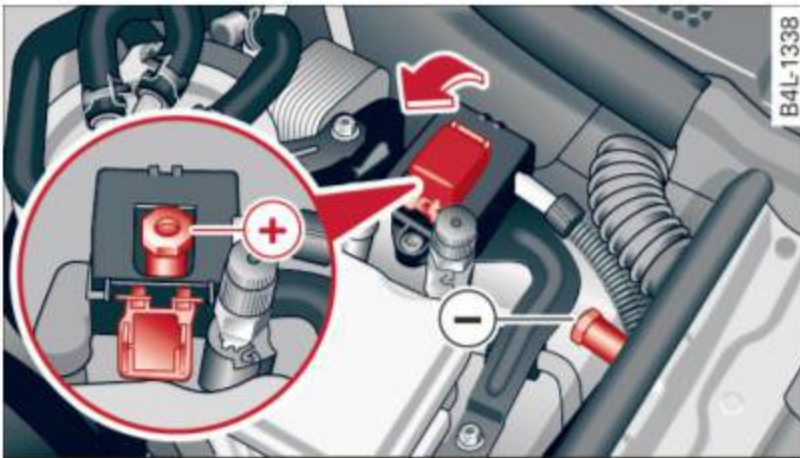

Fig. 273 Engine compartment: Connectors for jumper cables and charger

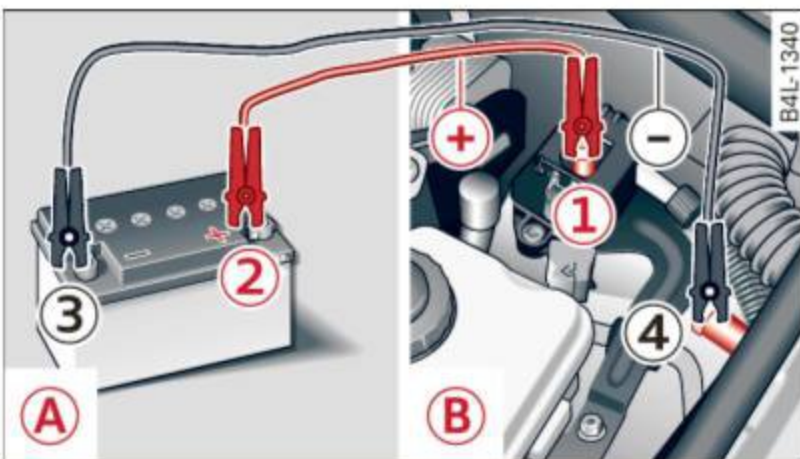

Fig. 274 Jump starting with the battery of another vehicle: A – booster battery, B – discharged vehicle battery

The procedure described below for connecting jumper cables is intended to provide a jump start for your vehicle.

### Vehicle with discharged battery:

- ▶ Turn off lights and accessories, move lever of automatic transmission to **N** (Neutral) or **P** (Park) and set parking brake.

### Connect POSITIVE (+) to POSITIVE (+) (red)

- ▶ Open the red cover on the positive pole ⇒ fig. 273.
1. Connect one end of the red positive cable on the **jump start bolt** ⇒ fig. 274 **1** (Bolts under red cover = “positive”) of the vehicle to be started **B**.
  2. Connect the other end to the positive terminal **2** of the booster battery **A**.

### Connect NEGATIVE (-) to NEGATIVE (-) (black)

3. Connect one end of the black negative cable to the negative terminal **3** of the booster battery **A**.
4. Connect the other end of the black negative cable to the **jump start bolt** **4** (Bolts with hex head = “negative”) of the vehicle to be started **B**.

### Starting the engine

- ▶ Start the engine of the vehicle with the booster battery **A**. Run the engine at a moderate speed.
- ▶ Start engine with discharged vehicle battery **B** in the usual manner.
- ▶ If the engine fails to start: do not keep the starter cranking for longer than 10 seconds. Wait for about 30 seconds and then try again.
- ▶ With engine running, remove jumper cables from both vehicles in the exact *reverse* order.
- ▶ Close the red cover on the positive pole.

The battery is vented to the outside to prevent gases from entering the vehicle interior. Make sure that the jumper clamps are well connected with their *metal parts in full contact* with the battery terminals.

### **!** WARNING

To avoid serious personal injury and damage to the vehicle, heed all warnings and instructions of the jumper cable manufacturer. If in doubt, call for road service.

- Jumper cables must be long enough so that the vehicles do not touch.
- When connecting jumper cables, make sure that they cannot get caught in any moving parts in the engine compartment.
- Before you check anything in the engine compartment, always read and heed all WARNINGS ⇒ *page 255, Engine compartment*.

### Note

Improper hook-up of jumper cables can ruin the generator.

- Always connect POSITIVE (+) to POSITIVE (+), and NEGATIVE (-) to NEGATIVE (-) ground post of the battery manager control unit.
- Check that all screw plugs on the battery cells are screwed in firmly. If not, tighten plugs prior to connecting clamp on negative battery terminal.
- Please note that the procedure for connecting a jumper cable as described above applies specifically to the case of your vehicle being jump started. When you are giving a jump start to another vehicle, do *not* connect the negative (-) cable to the negative (-) terminal on the discharged battery  ⇒ *fig. 274*. Instead, securely connect the negative (-) cable to either a solid metal component that is firmly bolted to the engine block or to the engine block itself. If the battery that is being charged does not vent to the outside, escaping battery gas could ignite and explode!

## Emergency towing with commercial tow truck

### General hints

*Your Audi requires special handling for towing.*

The following information is to be used by commercial tow truck operators who know how to operate their equipment safely.

- **Never tow your Audi, towing will cause damage to the engine and transmission.**
- **Never wrap the safety chains or winch cables around the brake lines.**
- **To prevent unnecessary damage, your Audi must be transported with a flat bed truck.**
- **To load the vehicle on to the flat bed, use the towing loop found in the vehicle tools and attach to the front or rear anchorage** ⇒ *page 317* and ⇒ *page 317*.



### WARNING

A vehicle being towed is not safe for passengers. Never allow anyone to ride in a vehicle being towed, for any reason.

## Front towing loop

Do not install the front towing loop until it is needed.

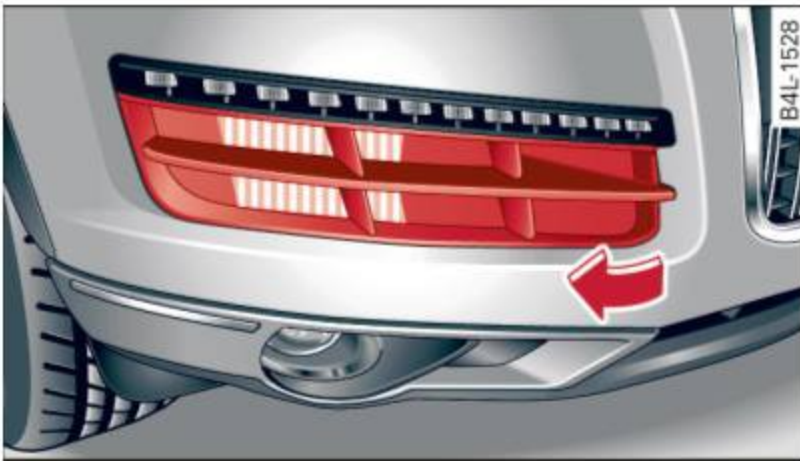

Fig. 275 Right front bumper: Removing the cover



Fig. 276 Right front bumper without cover: Screwing in towing loop

The towing loop fits into the threaded hole located on the right side of the front bumper and covered by a cover when not in use.

- ▶ Remove the towing loop from the vehicle tool kit ⇒ *page 301*.
- ▶ Carefully remove the cover ⇒ *fig. 275*.
- ▶ Screw the towing loop tightly into the threaded hole as far as it will go ⇒ *fig. 276*.

When it is no longer needed, unscrew the towing loop and put it back into the vehicle toolkit. Be sure to have the towing loop stored in the vehicle at all times.

### WARNING

If the towing loop is not screwed in as far as it will go, the thread can pull out when the vehicle is towed - potential risk of an accident.

## Rear towing loop

Do not install the rear towing loop until it is needed.



Fig. 277 Rear bumper: Cover



Fig. 278 Rear bumper: Screwing in towing loop

On the right side of the rear bumper there is a threaded hole for the towing loop. The threaded hole is protected by a cover.

- ▶ Remove the towing loop from the vehicle tool kit ⇒ *page 301*.
- ▶ To release the cover from the bumper, press it in by applying short, sharp pressure to the outer part ⇒ *fig. 277*.
- ▶ Screw the towing loop tightly into the threaded hole as far as it will go ⇒ *fig. 278*.

Unscrew the towing loop again after use and install the cover in the bumper. Return the towing loop to the toolkit. Be sure to have the towing loop stored in the vehicle at all times.

### WARNING

If the towing loop is not screwed in as far as it will go, the thread can pull out when the vehicle is towed - potential risk of an accident.

### Loading the vehicle onto a flat bed truck



Fig. 279 Vehicle on flat bed truck

#### Front hook up

- ▶ Align the vehicle with the centerline of the car carrier ramp.
- ▶ Attach the winch hook to the front towline eye previously installed.

#### Rear hook up

- ▶ Align the vehicle with the centerline of the car carrier ramp.
- ▶ Attach the winch hook to the rear towline eye previously installed.

#### **i** Tips

Check carefully to make sure the hook-up is secure before moving the car up the flat-bed truck ramp.

## Lifting vehicle

### Lifting with workshop hoist and with floor jack

The vehicle may only be lifted at the lifting points illustrated.

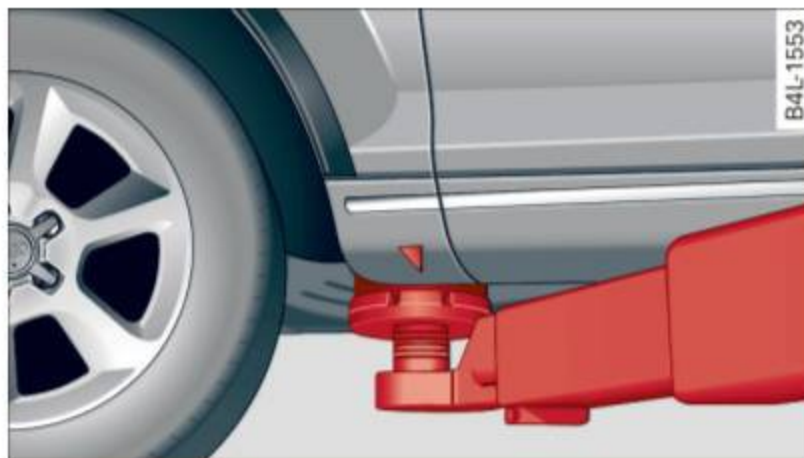

Fig. 280 Front lifting point

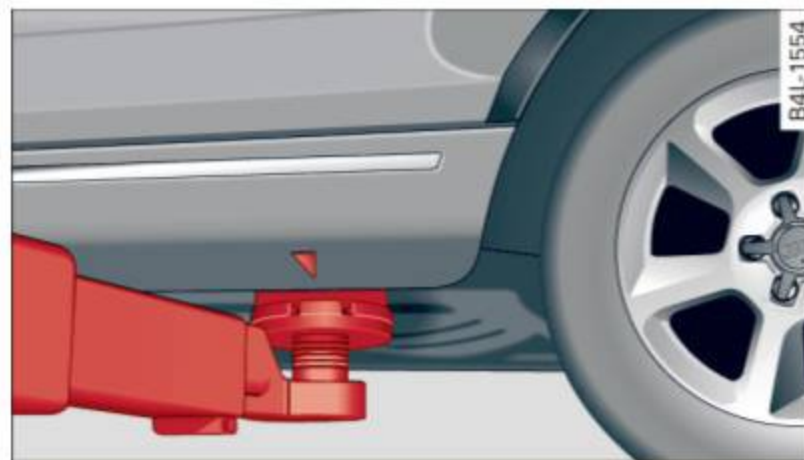



Fig. 281 Rear lifting point

- ▶ Read and heed WARNING ⇒ .
- ▶ Locate lifting points ⇒ *fig. 280* and ⇒ *fig. 281*.
- ▶ Adjust lifting arms of workshop hoist or floor jack to match vehicle lifting points.
- ▶ Insert a rubber pad between the floor jack/workshop hoist and the lifting points.

**If you must lift your vehicle with a floor jack to work underneath, be sure the vehicle is safely supported on stands intended for this purpose.**

#### Front lifting point

The lifting point is located on the floor pan reinforcement about at the same level as the jack mounting point ⇒ *fig. 280*. **Do not lift the vehicle at the vertical sill reinforcement.**

#### Rear lifting point

The lifting point is located on the vertical reinforcement of the lower sill for the onboard jack ⇒ *fig. 281*.

#### Lifting with vehicle jack

Refer to ⇒ *page 306*.

#### WARNING

- To reduce the risk of serious injury and vehicle damage.
- Always lift the vehicle only at the special workshop hoist and floor jack lift points illustrated ⇒ *fig. 280* and ⇒ *fig. 281*.
- Failure to lift the vehicle at these points could cause the vehicle to tilt or

fall from a lift if there is a change in vehicle weight distribution and balance. This might happen, for example, when heavy components such as the engine block or transmission are removed.

- When removing heavy components like these, anchor vehicle to hoist or add corresponding weights to maintain the center of gravity. Otherwise, the vehicle might tilt or slip off the hoist, causing serious personal injury.

### Note

- Be aware of the following points before lifting the vehicle:
  - **The vehicle should never be lifted or jacked up from underneath the engine oil pan, the transmission housing, the front or rear axle or the body side members. This could lead to serious damage.**
  - **To avoid damage to the underbody or chassis frame, a rubber pad must be inserted between the floor jack and the lift points.**
  - **Before driving over a workshop hoist, check that the vehicle weight does not exceed the permissible lifting capacity of the hoist.**
  - **Before driving over a workshop hoist, ensure that there is sufficient clearance between the hoist and low parts of the vehicle.**

## General information

### Explanation of technical data

Some of the technical data listed in this manual requires further explanation.

The technical data for your vehicle is listed in the charts starting on ⇒ page 322. This section provides general information, notes and restrictions which apply to this data.

### Vehicle identification

The key data is given on the vehicle identification number (VIN) plate and the vehicle data sticker.

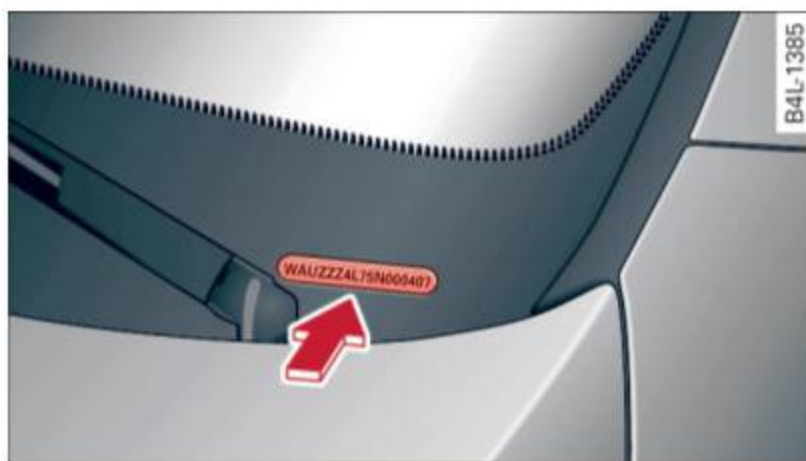

Fig. 282 Vehicle Identification Number (VIN) plate: location on driver's side dash panel

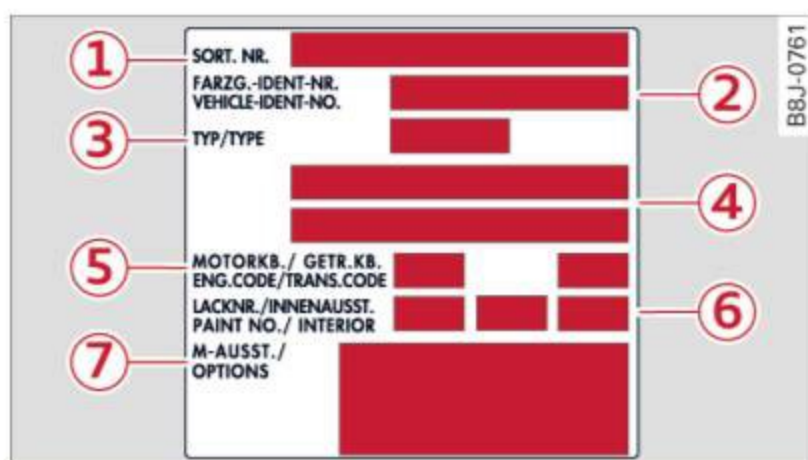

Fig. 283 The vehicle identification label – inside the luggage compartment

#### The Vehicle Identification Number (VIN)

is located on the driver's side so that it is visible from the outside through the windshield ⇒ fig. 282. You can also display the Vehicle Identification Number of your vehicle in the MMI. Select **CAR** function button > **Systems\*** control button > **Vehicle ID number (VIN)** or **CAR** function button > **Car systems\*** control button > **Servicing & checks** > **VIN number**.

#### The vehicle identification label

is located in the luggage compartment under the cargo floor cover.

The label ⇒ fig. 283 shows the following vehicle data:

- ① Production control No.
- ② Vehicle identification No.
- ③ Type code number
- ④ Type designation/engine output in Kilowatts
- ⑤ Engine and transmission code letter
- ⑥ Paint No./Interior
- ⑦ Optional equipment No.'s

Vehicle data 2 to 7 are also found in your Warranty & Maintenance booklet.

#### The safety compliance sticker

is your assurance that your new vehicle complies with all applicable Federal Motor Vehicle Safety Standards which were in effect at the time the vehicle was manufactured. You can find this sticker on the left door jamb. It shows the month and year of production and the vehicle identification number of your vehicle (perforation) as well as the Gross Vehicle Weight Rating (GVWR) and the Gross Axle Weight Rating (GAWR).

#### The high voltage warning label

is located on the lock carrier.

The spark ignition system complies with the Canadian standard ICES-002.

## Weights

### Gross Vehicle Weight Rating

The Gross Vehicle Weight Rating (GVWR), and the Gross Axle Weight Rating (GAWR) for front and rear are listed on a sticker on the left door jamb.

The Gross Vehicle Weight Rating includes the weight of the basic vehicle plus full fuel tank, oil and coolant, plus maximum load, which includes passenger weight (150 lbs/68 kg per ▶

designated seating position) and luggage weight ⇒ .

### Gross Axle Weight Rating

The Gross Axle Weight Rating is the maximum load that can be applied at each axle of the vehicle ⇒ .

### Vehicle capacity weight

The vehicle capacity weight (max. load) is listed on the driver's side B-pillar.

### Roof weight

The maximum permissible roof weight is **220 lb (100 kg)**. The roof weight is made up of the weight of the roof rack system and the weight of the object being transported ⇒ *page 84, Loading the roof rack.*

#### WARNING

- The Gross Vehicle Weight Rating for your vehicle, found on the safety compliance label on the driver's side B-pillar, must never be exceeded under any circumstances. Exceeding the Gross Vehicle Weight Rating of your vehicle is likely to damage your vehicle, and such damage will not be covered by your Limited New Vehicle Warranty. Exceeding the Gross Vehicle Weight Rating will also change the performance and handling characteristics of your vehicle, which could cause a crash resulting in serious injury or death.
- The Gross Vehicle Weight Rating for your vehicle would be exceeded if your vehicle is simultaneously equipped with Panoramic sliding sunroof; third-row seating; trailer towing equipment (factory or dealer-installed), and running boards (dealer-installed). **UNDER NO CIRCUMSTANCES MAY ALL SUCH ITEMS BE INSTALLED ON THE SAME VEHICLE.**
- The actual Gross Axle Weight Rating at the front and rear axles should not exceed the permissible weights, and their combination must not exceed the Gross Vehicle Weight Rating.

- Exceeding permissible weight ratings can result in vehicle damage, accidents and personal injury.

#### Note

- The vehicle capacity weight figures apply when the load is distributed evenly in the vehicle (passengers and luggage). When transporting a heavy load in the luggage compartment, carry the load as near to the rear axle as possible so that the vehicle's handling is not impaired.
- Do not exceed the maximum permissible axle loads or the maximum gross vehicle weight. Always remember that the vehicle's handling will be affected by the extra load. Therefore, adjust your speed accordingly.
- Always observe local regulations.

## Dimensions

The specifications refer to the basic model. Differences may occur depending on the model type and options ordered, for example, tire sizes.

#### Note

When driving up steep ramps, on rough roads, over curbs, etc. it is important to remember that some parts of your vehicle, such as spoilers or exhaust system components, may be close to the ground. Be careful not to damage them.

## Data

### 280 hp, 6-cylinder engine, with all-wheel drive

#### Engine data

|                        |   |                   |
|------------------------|---|-------------------|
| Maximum output SAE net | hp @ rpm  | 280 @ 4900 - 6500 |
| Maximum torque SAE net | lb-ft @ rpm   | 295 @ 2150 - 4900 |
| No. of cylinders       |   | 6 cylinder        |
| Displacement           | CID (cm <sup>3</sup> )  | 182.8 (2995)      |
| Stroke                 | in (mm)   | 3.50 (89.0)       |
| Bore                   | in (mm)   | 3.33 (84.5)       |
| Compression ratio      |   | 10.5 : 1          |
| Fuel                   | <b>Premium unleaded (91 AKI)</b> Recommended for maximum engine performance. Further details ⇒ <i>page 256, Fuel supply</i> |                   |

#### Dimensions (approx.)

|  |         |              |
|--|---------|--------------|
| Length (with license plate bracket)    | in (mm) | 200.3 (5089) |
| Width (with outside mirrors folded)    | in (mm) | 78.1 (1983)  |
| Height (unloaded)                      | in (mm) | 68.4 (1737)  |
| Turning circle diameter (curb to curb) | ft (m)  | 39.4 (12)    |

#### Capacities (approx.)

|   |                 |                 |
|---|-----------------|-----------------|
| <b>Fuel tank</b>  |                 |                 |
| - Total capacity  | gal (liters)    | 26.4 (100)      |
| - Reserve (of total capacity)                           | gal (liters)    | 2.6-3.2 (10-12) |
| <b>Windshield and headlight* washer fluid container</b> | quarts (liters) | 4.8 (4.5)       |
| <b>Engine oil with filter change</b>                    | quarts (liters) | 7.2 (6.8)       |

## 333 hp, 6-cylinder engine, with all-wheel drive

### Engine data

|                        |   |                   |
|------------------------|---|-------------------|
| Maximum output SAE net | hp @ rpm  | 333 @ 5500 - 6500 |
| Maximum torque SAE net | lb-ft @ rpm   | 325 @ 2900 - 5300 |
| No. of cylinders       |   | 6 cylinder        |
| Displacement           | CID (cm <sup>3</sup> )  | 182.8 (2995)      |
| Stroke                 | in (mm)   | 3.50 (89.0)       |
| Bore                   | in (mm)   | 3.33 (84.5)       |
| Compression ratio      |   | 10.5 : 1          |
| Fuel                   | <b>Premium unleaded (91 AKI)</b> Recommended for maximum engine performance. Further details ⇨ <i>page 256, Fuel supply</i> |                   |

### Dimensions (approx.)

|  |         |              |
|--|---------|--------------|
| Length (with license plate bracket)    | in (mm) | 200.3 (5089) |
| Width (with outside mirrors folded)    | in (mm) | 78.1 (1983)  |
| Height (unloaded)                      | in (mm) | 68.4 (1737)  |
| Turning circle diameter (curb to curb) | ft (m)  | 39.4 (12)    |

### Capacities (approx.)

|   |                 |                 |
|---|-----------------|-----------------|
| <b>Fuel tank</b>  |                 |                 |
| - Total capacity  | gal (liters)    | 26.4 (100)      |
| - Reserve (of total capacity)                           | gal (liters)    | 2.6-3.2 (10-12) |
| <b>Windshield and headlight* washer fluid container</b> | quarts (liters) | 4.8 (4.5)       |
| <b>Engine oil with filter change</b>                    | quarts (liters) | 7.2 (6.8)       |

## 240 hp, 6-cylinder engine, with all-wheel drive

Applies to vehicles: with diesel engine

### Engine data

|                        |   |                   |
|------------------------|---|-------------------|
| Maximum output SAE net | hp @ rpm  | 240 @ 3500 - 4000 |
| Maximum torque SAE net | lb-ft @ rpm   | 406 @ 1750 - 2250 |
| No. of cylinders       |   | 6 cylinder        |
| Displacement           | CID (cm <sup>3</sup> )  | 181.1 (2967)      |
| Stroke                 | in (mm)   | 3.60 (91.4)       |
| Bore                   | in (mm)   | 3.27 (83.0)       |
| Compression ratio      |   | 16.8 : 1          |
| Fuel                   | <b>ULSD-Diesel No. 2</b> Further details ⇨ <i>page 257, Diesel fuel</i> |                   |

### Dimensions (approx.)

|  |         |              |
|--|---------|--------------|
| Length (with license plate bracket)    | in (mm) | 200.3 (5089) |
| Width (with outside mirrors folded)    | in (mm) | 78.1 (1983)  |
| Height (unloaded)                      | in (mm) | 68.4 (1737)  |
| Turning circle diameter (curb to curb) | ft (m)  | 39.4 (12)    |

### Capacities (approx.)

|   |                 |                 |
|---|-----------------|-----------------|
| <b>Fuel tank</b>  |                 |                 |
| - Total capacity  | gal (liters)    | 26.4 (100)      |
| - Reserve (of total capacity)                           | gal (liters)    | 2.6-3.2 (10-12) |
| <b>Windshield and headlight* washer fluid container</b> | quarts (liters) | 4.8 (4.5)       |
| <b>Engine oil with filter change</b>                    | quarts (liters) | 8.1 (7.7)       |

## Consumer Information

### Warranty coverages

Your Audi is covered by the following warranties:

- *New Vehicle Limited Warranty*
- *Limited Warranty Against Corrosion Performance*
- *Emissions Control System Warranty*
- *Emissions Performance Warranty*
- *California Emissions Control Warranty (USA vehicles only)*
- *California Emissions Performance Warranty (USA vehicles only)*

Detailed information regarding your warranties can be found in your **Warranty & Maintenance booklet**.

### Operating your vehicle outside the U.S.A. or Canada

Government regulations in the United States and Canada require that automobiles meet specific emission regulations and safety standards. Therefore, vehicles built for the U.S.A. and Canada differ from vehicles sold in other countries.

If you plan to take your vehicle outside the continental limits of the United States or Canada, there is the possibility that:

- unleaded fuels for vehicles with catalytic converter may not be available;
- fuel may have a considerably lower octane rating. Improper fuel may cause engine damage;
- service may be inadequate due to lack of proper service facilities, tools or testing equipment;
- replacement parts may not be readily available.
- Navigation systems for vehicles built for the U.S.A. and Canada will not necessarily work in Europe, and may not work in other countries outside North America.

#### Note

Audi cannot be responsible for mechanical damage that could result from inadequate fuel, service or parts availability.

### Audi Service Repair Manuals and Literature

Audi Official Factory Service Manuals and Literature are published as soon as possible after model introduction. Service Manuals and literature are available to order from the Audi Technical Literature Ordering Center at:

[www.audi.techliterature.com](http://www.audi.techliterature.com)

### Maintenance

#### General

Your vehicle has been designed to help keep maintenance requirements to a minimum. However, a certain amount of regular maintenance is still necessary to assure your vehicle's safety, economy and reliability. For detailed vehicle maintenance consult your Warranty & Maintenance booklet.

**Under difficult operating conditions**, for example at extremely low outside temperatures, in very dusty regions, when towing a trailer very frequently, etc., some service work should be performed between the intervals specified. This applies particularly to:

- oil changes, and
- cleaning or replacing the air filter.

#### For the sake of the environment

By regularly maintaining your vehicle, you help make sure that emission standards are maintained, thus minimizing adverse effects on the environment.

#### Important considerations for you and your vehicle

The increasing use of electronics, sophisticated fuel injection and emission control systems, and the generally increasing technical

complexity of today's automobiles, have steadily reduced the scope of maintenance and repairs which can be carried out by vehicle owners. **Also, safety and environmental** concerns place very strict limits on the nature of repairs and adjustments to engine and transmission parts which an owner can perform.

Maintenance, adjustments and repairs usually require special tools, testing devices and other equipment available to specially trained workshop personnel in order to assure proper performance, reliability and safety of the vehicle and its many systems.

Improper maintenance, adjustments and repairs can impair the operation and reliability of your vehicle and even void your vehicle warranty. Therefore, proof of servicing in accordance with the maintenance schedule may be a condition for upholding a possible warranty claim made within the warranty period.

Above all, operational safety can be adversely affected, creating unnecessary risks for you and your passengers.

If in doubt about any servicing, have it done by your authorized Audi dealer or any other properly equipped and qualified workshop. We strongly urge you to give your authorized Audi dealer the opportunity to perform all scheduled maintenance and necessary repairs. Your dealer has the facilities, original parts and trained specialists to keep your vehicle running properly.

### **Performing limited maintenance yourself**

The following pages describe a limited number of procedures which can be performed on your vehicle with ordinary tools, should the need arise and trained personnel be unavailable. Before performing any of these procedures, always thoroughly read all of the applicable text and carefully follow the instructions given. Always rigorously observe the **WARNINGS** provided.

**Before you check anything in the engine compartment, always read and heed all**

**WARNINGS** ⇨ ⚠ and ⇨ ⚠ *in Working in the engine compartment on page 264.*

### **⚠ WARNING**

- Serious personal injury may occur as a result of improperly performed maintenance, adjustments or repairs.
- Always be extremely careful when working on the vehicle. Always follow commonly accepted safety practices and general common sense. Never risk personal injury.
- Do not attempt any of the maintenance, checks or repairs described on the following pages if you are not fully familiar with these or other procedures with respect to the vehicle, or are uncertain how to proceed.
- Do not do any work without the proper tools and equipment. Have the necessary work done by your authorized Audi dealer or another properly equipped and qualified workshop.
- The engine compartment of any motor vehicle is a potentially hazardous area. Never reach into the area around or touch the radiator fan. It is temperature controlled and can switch on suddenly - even when the engine is off and the ignition key has been removed. The radiator fan switches on automatically when the coolant reaches a certain temperature and will continue to run until the coolant temperature drops.
- Always remove the ignition key before anyone gets under the vehicle.
- Always support your vehicle with safety stands if it is necessary to work underneath the vehicle. The jack supplied with the vehicle is not adequate for this purpose and could collapse causing serious personal injury.
- If you must work underneath the vehicle with the wheels on the ground, always make sure the vehicle is on level ground, that the wheels are always securely blocked and that the engine cannot be started.

- Always make sure the transmission selector lever (automatic transmission) is in “P” (Park position) and the park brake is firmly applied.



### For the sake of the environment

- Changing the engine settings will adversely affect emission levels. This is detrimental to the environment and increases fuel consumption.
- Always observe environmental regulations when disposing of old engine oil, used brake fluid, dirty engine coolant, spent batteries or worn out tires.
- Undeployed airbag modules and pretensioners might be classified as Perchlorate Material -special handling may apply, see [www.dtsc.ca.gov/hazardous-waste/perchlorate](http://www.dtsc.ca.gov/hazardous-waste/perchlorate). When the vehicle or parts of the restraint system including airbag modules safety belts with pretensioners are scrapped, all applicable laws and regulations must be observed. Your authorized Audi dealer is familiar with these requirements and we recommend that you have your dealer perform this service for you.

## Additional accessories, modifications and parts replacement

### Additional accessories and parts replacement

*Always consult an authorized Audi dealer before purchasing accessories.*

Your vehicle incorporates the latest safety design features ensuring a high standard of active and passive safety.

This safety could be compromised by non-approved changes to the vehicle. For this reason, if parts have to be replaced, please observe the following points when installing additional accessories:

Approved Audi accessories and genuine Audi parts are available from authorized Audi dealers.

These dealers also have the necessary facilities, tools and trained specialists to install the parts and accessories properly.



### WARNING

- Using the wrong spare parts or using non-approved accessories can cause damage to the vehicle and serious personal injury.
- Use only accessories expressly approved by Audi and genuine Audi spare parts
  - These parts and accessories have been specially designed to be used on your vehicle.
  - Never install accessories such as telephone cradles or beverage holders on airbag covers or within the airbag deployment zones. Doing so will increase the risk of injury if airbags are triggered in an accident!
  - Before you check anything in the engine compartment, always read and heed all WARNINGS ⇨ *page 255*.



### Note

- If items other than genuine Audi spare parts, add-on equipment and accessory items are used or if repair work is not performed according to specified methods, this can result in severe damage to your vehicle's engine and body (such as corrosion) and adversely affect your vehicle's warranty.
- If emergency repairs must be performed elsewhere, have the vehicle examined by an authorized Audi dealer as soon as possible.
- The manufacturer cannot be held liable for damage which occurs due to failure to comply with these stipulations.

## Technical Modifications

*Our guidelines must be complied with when technical modifications are made.*

Always consult an authorized Audi dealer **before** starting work on any modifications.

This will help ensure that vehicle function, performance and safety are not impaired ⇒ ⚠.

Attempting to work on electronic components and the software used with them can cause malfunctions. Because of the way electronic components are interconnected with each other, such malfunctions can also have an adverse affect on other systems that are not directly involved. This means that you risk both a substantial reduction in the operational safety of your vehicle and an increased wear of vehicle parts ⇒ ⚠.

Authorized Audi dealers will perform this work in a professional and competent manner or, in special cases, refer you to a professional company that specializes in such modifications.

### **WARNING**

Improper repairs and modifications can change the way vehicle systems work and cause damage to the vehicle and serious personal injury.

### **Note**

If emergency repairs must be performed elsewhere, have the vehicle examined by an authorized Audi dealer as soon as possible.

## Declaration of Compliance, Telecommunications and Electronic Systems

*Radio Frequency Devices and Radio Communication Equipment User Manual Notice.*

The manufacturer is not responsible for any radio or TV interference caused by unauthorized modifications to this equipment.

### Devices

The following devices each comply with FCC Part 15.19, FCC Part 15.21 and RSS-Gen Issue 1:

- Adaptive cruise control
- Convenience key
- Audi side assist
- Cell phone package
- Electronic immobilizer
- HomeLink® universal remote control
- Remote control key

### FCC Part 15.19

This device complies with part 15 of the FCC Rules. Operation is subject to the following two conditions:

- (1) This device may not cause harmful interference, and
- (2) this device must accept any interference received, including interference that may cause undesired operation.

### FCC Part 15.21

CAUTION:

Changes or modifications not expressly approved by the party responsible for compliance could void the user's authority to operate the equipment.

### RSS-Gen Issue 1

Operation is subject to the following two conditions:

- (1) this device may not cause interference, and

(2) this device must accept any interference, including interference that may cause undesired operation of the device.

## A

- Accessories ..... 327
- Adaptive Air Suspension ..... 155
  - Cargo mode in the MMI ..... 160
  - Controls ..... 155
  - Description ..... 155
  - High level ..... 155
  - Highway level ..... 155
  - Instrument cluster display ..... 158
  - Jacking mode when changing a flat tire ..... 159
  - Low level ..... 155
  - Normal level ..... 155
  - Segment display ..... 157
  - Setting the driving modes ..... 157
  - Trailer towing mode ..... 159
  - Using switch for cargo mode ..... 160
  - Warning/indicator lights ..... 17
- Adaptive cruise control ..... 113
  - Changing speed ..... 117
  - Cleaning sensors ..... 247
  - Driver information ..... 120
  - Driver intervention prompt ..... 124
  - Driving in traffic ..... 114
  - Driving program ..... 124
  - Error messages ..... 122
  - Open road ..... 114
  - Override ..... 114
  - Request for driver to assume control .. 114
  - Save speed ..... 116
  - Setting distance ..... 118
  - Settings ..... 124
  - Setting time interval ..... 118
  - Special driving situations ..... 125
  - Status messages ..... 122
  - Switching on and off ..... 116
  - System limits ..... 125
  - Temporarily turning off ..... 118
  - warning/indicator lights ..... 121
- Adaptive light ..... 59
  - defective ..... 37
- AdBlue ..... 261
  - Filling ..... 262
  - Messages in the instrument cluster display ..... 261
- Adding
  - Engine coolant ..... 273
  - Engine oil ..... 270
  - Windshield washer fluid ..... 279
- Additional accessories ..... 327
- Additives
  - Engine oil ..... 270
- Adjusting
  - Instrument cluster illumination ..... 13
  - Steering column electrically ..... 103
  - Steering column manually ..... 103
- Adjusting front seats ..... 71
- Airbag
  - Warning/indicator lights ..... 16
- Airbag system ..... 184, 201
  - Advanced Airbag System ..... 188
  - Advanced Airbag System components . 191
  - Care ..... 198
  - Children ..... 206
  - Child restraints ..... 207
  - Components (front airbags) ..... 191
  - Danger of fitting a child safety seat on the front passenger seat ..... 186
  - Disposal ..... 198
  - Front airbags ..... 188, 189
  - How do the front airbags work? ..... 193
  - How many airbags does my vehicle have? ..... 191
  - How the Advanced Airbag System components work together ..... 192
  - Important things to know ..... 184
  - Indicator light ..... 195
  - Monitoring ..... 195
  - PASSENGER AIR BAG OFF light ..... 195
  - Repairs ..... 198
  - Safety instructions ..... 197
  - Side airbags ..... 199
  - Side curtain airbags ..... 202
  - Weight-sensing mat ..... 206
  - When must the system be inspected? . 195
- Air conditioning
  - refer to* Climate controls ..... 91
- Air distribution
  - Climate controls ..... 94
  - Four-zone automatic comfort air conditioning ..... 99
- Air pollutants filter
  - Climate controls ..... 91

- All-wheel drive ..... 231  
 Winter tires ..... 295
- Alloy wheels ..... 250
- Alternator  
 Malfunction ..... 31
- Ambience lighting  
 Lighting profiles ..... 62
- Anti-freeze  
*refer to* Engine coolant system ..... 271
- Anti-lock brake system  
 How the ABS system works ..... 229  
 Warning/indicator lights ..... 18
- Anti-Slip Regulation System (ASR)  
 How the system works ..... 227
- Anti-theft systems  
 Anti-theft alarm system ..... 50  
 Electronic immobilizer ..... 40
- Approach/departure angle ..... 238
- Ashtray ..... 86
- ASR  
 How the Anti-Slip Regulation System works ..... 227
- Asterisk  
 What does it mean when something is marked with an asterisk? ..... 6
- Audi braking guard ..... 127  
 Error messages ..... 128  
 Settings ..... 128  
 Status messages ..... 128  
 Switching on and off ..... 128
- Audi Service Repair Manuals and Literature ..... 325
- Auto-Check Control ..... 30
- Automatic belt retractor ..... 179
- Automatic car wash  
*refer to* Washing ..... 246
- Automatic mode  
 Four-zone automatic comfort air conditioning ..... 98
- Automatic Shift Lock (ASL) ..... 139
- Automatic transmission ..... 137  
 Automatic Shift Lock (ASL) ..... 139  
 Driving ..... 137  
 Dynamic shift program ..... 140  
 Emergency mode ..... 141  
 Emergency release for selector lever .. 142  
 Ignition key safety lock ..... 105
- Kick-down ..... 140
- Manual shift program ..... 140
- Selector lever ..... 138
- Shift buttons ..... 141
- Steering wheel with tiptronic® ..... 141
- AUTO mode  
 AC climate controls ..... 94
- Auto Safety Hotline ..... 172
- Average speed ..... 24
- Avoid damaging the vehicle ..... 236
- B**
- Bass box ..... 302
- Battery ..... 275  
 Battery location ..... 276  
 Charging ..... 277  
 Important warnings when working on the battery ..... 276  
 Jump starting ..... 314  
 Low ..... 231  
 Replacing the battery ..... 279  
 State of charge ..... 231  
 Voltage ..... 36  
 Winter operation ..... 275  
 Working on the battery ..... 276
- Before driving ..... 165
- Blended gasoline ..... 256
- Body cavity sealing ..... 250
- Booster seats ..... 213
- Brake assistant ..... 230
- Brake booster ..... 229
- Brake fluid  
 Changing the brake fluid ..... 275  
 Checking the brake fluid level ..... 274  
 Reservoir ..... 274  
 What is the correct brake fluid level? .. 274  
 What should I do if the brake fluid warning light comes on? ..... 274
- Brake light  
 Defective ..... 23
- Brake system ..... 274  
 Anti-lock brake system ..... 18  
 Brake fluid ..... 274  
 Brake fluid specifications for refill and replacement ..... 275  
 Brake pads ..... 234  
 General information ..... 228

- How does moisture or road salt affect the brakes? . . . . . 228
  - Malfunction . . . . . 32
  - Parking brake . . . . . 109
  - Warning/indicator lights . . . . . 19
  - Worn brake pads symbol . . . . . 36
  - Braking guard
    - refer to Audi braking guard* . . . . . 127
  - Break-in period . . . . . 234
    - Brake pads . . . . . 234
    - Tires . . . . . 234
  - Breakover angle . . . . . 238
  - Bulbs . . . . . 312
  - Bumper cover
    - Caution when parking near a parking barrier or curb . . . . . 110
- C**
- California Proposition 65 Warning . . . . . 265
    - Battery specific . . . . . 277
  - Capacities . . . . . 322
  - Car - Systems
    - Ambience lighting . . . . . 62
    - Lighting profiles . . . . . 62
  - Car care . . . . . 245
    - Interior . . . . . 251
    - Plastic and vinyl . . . . . 248
  - Care of exterior . . . . . 245
  - Cargo area
    - refer to Loading the luggage compartment* . . . . . 171
  - Cargo floor . . . . . 82
  - Cargo net . . . . . 80
  - Catalytic converter . . . . . 235
  - Center armrest
    - Cup holder . . . . . 77
    - Storage compartment . . . . . 77
  - Center console in rear . . . . . 78
  - Central locking
    - Emergency locking . . . . . 45
    - Panoramic sliding sunroof . . . . . 55
  - Certification . . . . . 328
  - Changing a flat tire . . . . . 304
  - Changing a wheel . . . . . 304
  - Changing engine oil . . . . . 270
  - Chassis
    - Undercoating . . . . . 250
      - also refer to Adaptive Air Suspension* . . . . . 155, 157
  - CHECK button . . . . . 12
  - Checking
    - Engine coolant level . . . . . 272
  - Checking tire pressure . . . . . 286
  - Child restraints
    - Danger of using child restraints in the front seat . . . . . 186
    - Where can I get additional information about child restraints and their use? . . . . . 224
  - Child restraint system anchors . . . . . 218
  - Child safety . . . . . 205
    - Convertible locking retractor . . . . . 215
    - Guidance fixtures for lower anchorages . . . . . 220
    - Important safety instructions for using child safety seats . . . . . 208
    - Important things to know when driving with children . . . . . 205
    - Installing a child restraint using the LATCH system . . . . . 221
    - Mounting and releasing the anchorage hook . . . . . 221
    - Tether anchors . . . . . 222
    - Tether straps . . . . . 222
  - Child safety lock
    - rear doors (power) . . . . . 48
  - Child safety seat
    - Unused safety belts on the rear seat . . . . . 210
  - Child safety seats . . . . . 211
    - Booster seats . . . . . 213
    - Convertible child seats . . . . . 212
    - Convertible locking retractor . . . . . 215
    - Danger of using child restraints in the front seat . . . . . 186
    - How do I properly install a child safety seat in my vehicle? . . . . . 208
    - Infant seats . . . . . 211
    - Installing . . . . . 215
    - LATCH system . . . . . 221
    - Safety instructions . . . . . 208
  - Child seats
    - Lower anchorages . . . . . 219

- Cleaning
    - Alcantara (synthetic suede) . . . . . 254
    - Engine compartment . . . . . 255
    - Exhaust tail pipes . . . . . 250
    - Fabrics and fabric coverings . . . . . 251
    - Instrument panel . . . . . 252
    - Interior . . . . . 251
    - Leather . . . . . 253
    - MMI control console . . . . . 251
    - MMI display . . . . . 251
    - Plastic and vinyl . . . . . 248
    - Plastic parts . . . . . 252
    - Safety belts . . . . . 254
    - trim strips . . . . . 248
    - Trim strips . . . . . 248
  - Cleaning and protection . . . . . 245
  - Climate control . . . . . 91
    - Synchronizing . . . . . 92
    - Warm and cold . . . . . 91
  - Climate controls
    - Air conditioner on/off . . . . . 93
    - Air distribution . . . . . 94
    - Air outlets . . . . . 96
    - Air outlets (rear) . . . . . 96
    - Air recirculation . . . . . 95
    - AUTO (standard setting) . . . . . 94
    - Basic settings . . . . . 99
    - Controls . . . . . 92
    - Defrosting/defogging . . . . . 94
    - Description . . . . . 91
    - Energy management . . . . . 91
    - Fan . . . . . 94
    - Front seat ventilation . . . . . 100
    - Heated seats, front . . . . . 100
    - Key coded setting . . . . . 91
    - Recirculation mode (automatic) . . . . . 99
    - Recommended settings . . . . . 91
    - Residual heat . . . . . 93
    - Setting the temperature . . . . . 94
    - Supplementary heater . . . . . 100
    - Synchronization . . . . . 99
    - Turning on and off . . . . . 93
    - Using climate control economically . . . . . 97
  - Clock . . . . . 11
  - Closing
    - Panoramic sliding sunroof . . . . . 55
  - Coat hooks . . . . . 89
  - Cold tire inflation pressure . . . . . 284
  - Compass mirror . . . . . 69
  - Compliance . . . . . 328
  - Consumer Information . . . . . 172, 325
  - Contacting NHTSA . . . . . 172
  - Convenience key . . . . . 49
    - Driver messages . . . . . 108
    - Locking vehicle . . . . . 50
    - START button . . . . . 107
    - Starting engine . . . . . 107
    - STOP button . . . . . 108
    - Switching engine off . . . . . 108
    - Switching on ignition . . . . . 107
    - Unlocking vehicle . . . . . 49
  - Convertible child safety seats . . . . . 212
  - Convertible locking retractor
    - Activating . . . . . 217
    - Deactivating . . . . . 218
    - Using to secure a child safety seat . . . . . 215, 217
  - Coolant system . . . . . 271
  - Cooling box in glove compartment . . . . . 88
  - Cooling System
    - Expansion tank . . . . . 272
  - Cornering light . . . . . 59
  - Cruise control
    - Changing speed . . . . . 112
    - Presetting your speed . . . . . 112
    - Switching off . . . . . 112
    - Switching on . . . . . 111
    - Warning/indicator lights . . . . . 18
    - also refer to Adaptive cruise control . . . . . 113*
  - Cruising range . . . . . 24
  - Cupholder . . . . . 78, 85, 86
- ## D
- Damping
    - refer to Adaptive Air Suspension . . . . . 155, 157*
  - Data . . . . . 322
  - Data recorder . . . . . 225
  - Date display . . . . . 11
  - Daytime running lights . . . . . 57, 58
  - Declaration of compliance
    - Adaptive cruise control . . . . . 328
    - Audi side assist . . . . . 328
    - Cell phone package . . . . . 328
    - Convenience key . . . . . 328
    - Electronic immobilizer . . . . . 328

- HomeLink® universal remote control . . . 328
  - Remote control key . . . . . 328
  - def
    - What does this mean when it appears in the trip odometer display? . . . . . 12
  - Defective light bulb warning . . . . . 23
  - Defrosting/defogging the windows . . . . . 94
  - Defrosting/defogging windows . . . . . 96
  - Determining correct load limit . . . . . 288
  - Diesel fuel . . . . . 257
  - Diesel particulate filter . . . . . 37, 235
  - Digital clock . . . . . 11
  - Digital compass . . . . . 69
  - Digital speedometer . . . . . 22
  - Dimensions . . . . . 321
  - Dimming the rearview mirror . . . . . 69
  - Dipstick
    - Reading the dipstick properly . . . . . 269
  - Distance control system
    - refer to* Adaptive cruise control . . . . . 113
  - Doors
    - Power child safety lock . . . . . 48
  - Driver information system . . . . . 21
    - Digital speedometer . . . . . 22
    - Driver information messages . . . . . 30
    - Open door or rear lid warning . . . . . 22
    - Outside temperature display . . . . . 22
    - Sound system display . . . . . 21
  - Driver seat
    - refer to* Seating position . . . . . 166
  - Driver's seat . . . . . 72
  - Driver's seat memory . . . . . 73
    - Activating remote control key . . . . . 74
    - Recalling a seat position . . . . . 73
    - Storing a seat position . . . . . 73
  - Driving messages . . . . . 30
  - Driving mode
    - refer to* Adaptive Air Suspension . . . 155, 157
  - Driving offroad
    - Driving through water . . . . . 239
    - Driving tips . . . . . 238
    - Rules of behavior . . . . . 238
    - Sand and mud . . . . . 239
    - Snow-covered ground . . . . . 239
    - Unpaved roads . . . . . 239
  - Driving safely . . . . . 165
  - Driving through water . . . . . 239
  - Driving time . . . . . 24
  - Duplicate key . . . . . 38
  - Dust filter
    - Climate controls . . . . . 91
- ## E
- Easy entry feature . . . . . 104
  - Efficiency program . . . . . 26
    - Fuel economy messages . . . . . 27
    - Memory levels . . . . . 25
    - Other equipment . . . . . 27
  - Electric seat adjustment
    - refer to* Power seat . . . . . 72
  - Electronic differential lock (EDL)
    - How the system works . . . . . 227
    - Warning/indicator lights . . . . . 18
  - Electronic immobilizer . . . . . 40
  - Electronic power control
    - (EPC) warning/indicator light . . . . . 15
  - Electronic speed limiter . . . . . 28
  - Electronic Stabilization Control (ESC)
    - Hill descent control . . . . . 225
    - How the system works . . . . . 225
    - Offroad mode . . . . . 225
    - Warning/indicator lights . . . . . 16
  - Emergency flasher . . . . . 60
    - Warning/indicator lights . . . . . 16
  - Emergency locking of doors . . . . . 45
  - Emergency operation
    - Rear lid . . . . . 48
  - Emergency starting . . . . . 314
  - Emergency towing . . . . . 316
  - Energy management . . . . . 231
    - Battery power . . . . . 233
    - Driver notification . . . . . 233
  - Engine
    - Compartment . . . . . 266
    - Coolant . . . . . 271
    - Hood . . . . . 264
    - Starting . . . . . 105, 106
    - Starting with jumper cables . . . . . 314
    - Stopping . . . . . 106
  - Engine compartment
    - Safety instructions . . . . . 264
    - Working the engine compartment . . . . 264

- Engine coolant system . . . . . 271
- Adding coolant . . . . . 273
  - Checking coolant level . . . . . 272
  - Checking the engine coolant level . . . . . 272
  - Malfunction . . . . . 32
  - Radiator fan . . . . . 274
- Engine coolant temperature
- Temperature gauge . . . . . 10
- Engine data . . . . . 322
- Engine hood
- Closing . . . . . 264
  - How to release the hood . . . . . 264
- Engine oil . . . . . 266
- Adding . . . . . 270
  - Additives . . . . . 270
  - Changing . . . . . 270
  - Checking the engine oil level . . . . . 269
  - Consumption . . . . . 268
  - Indications and conditions requiring extra checking . . . . . 269
  - Oil grades . . . . . 266
  - Recommended oil check intervals . . . . . 269
  - Specification and viscosity . . . . . 266
- Engine oil level . . . . . 36
- Engine oil pressure
- Malfunction . . . . . 33
- Engine oil sensor defective . . . . . 36
- Engine speed limitation . . . . . 36
- Entry assist
- Rear seats . . . . . 75
- Environment
- Break-in period . . . . . 234
  - Catalytic converter . . . . . 235
  - Diesel particulate filter . . . . . 235
  - Disposing of your vehicle battery . . . . . 279
  - Driving at high speeds . . . . . 236
  - Driving to minimize pollution and noise . . . . . 236
  - Fuel . . . . . 259
  - Fuel economy . . . . . 236
  - Leaks under your vehicle . . . . . 264
  - Letting the vehicle stand and warm up . . . . . 236
  - Proper disposal of drained brake fluid . . . . . 275
  - Proper disposal of drained engine coolant . . . . . 273
  - Proper disposal of drained engine oil . . . . . 270
  - Recycling used engine oil . . . . . 270
  - Unleaded fuel . . . . . 256
  - What should I do with an old battery? . . . . . 279
- EPC
- refer to* Electronic power control . . . . . 15
- ESC
- refer to* Electronic Stabilization Control (ESC) . . . . . 16
- Event Data Recorder (EDR) . . . . . 225
- Exhaust tail pipes
- Cleaning . . . . . 250
- Expansion tank . . . . . 272
- Explanation of some technical terms . . . . . 238
- Exterior lighting in the mirror housing . . . . . 59
- Exterior mirrors
- Adjusting . . . . . 68
  - Dimming . . . . . 69
  - Heating . . . . . 68
- Eyeglasses compartment . . . . . 89
- F**
- Fall line . . . . . 238
- Fan
- Four-zone automatic comfort air conditioning . . . . . 98
  - Radiator . . . . . 274
- Fastening
- Booster seats . . . . . 213
  - Convertible child safety seats . . . . . 212
  - Infant seats . . . . . 211
- Flat tire
- Changing . . . . . 304
- Floor mats . . . . . 170
- Fog lights . . . . . 58
- Folding chocks . . . . . 301
- Folding master key with remote control . . . . . 38
- Foot pedals . . . . . 170
- For the sake of the environment
- Gasoline fumes and the environment . . . . . 259
  - Letting your engine warm up . . . . . 106
  - Reducing engine noise by early upshifting . . . . . 10
  - Refueling . . . . . 259
  - Saving fuel by early upshifting . . . . . 10
  - Using the rear window defogger . . . . . 95
- Four-zone automatic comfort air conditioning . . . . . 97
- Automatic mode in rear . . . . . 98
  - Heated rear seats . . . . . 101

- Rear air distribution . . . . . 99
- Rear controls . . . . . 97
- Rear fan . . . . . 98
- Rear operation . . . . . 100
- Rear temperature . . . . . 98
- Synchronization . . . . . 100
- Turning on/off . . . . . 98
- Front airbags
- Description . . . . . 188
- How they work . . . . . 193
- Frontal collisions and the laws of physics 176
- Front fog lights . . . . . 58
- Front seats . . . . . 71
- Adjusting . . . . . 167
- Child restraints in the front seat . . . . . 186
- Fuel
- Additives . . . . . 256
- Blended gasoline . . . . . 256
- Consumption . . . . . 24
- Filler neck . . . . . 258
- Fuel gauge . . . . . 12
- Gasoline . . . . . 256
- Gasoline additives . . . . . 257
- Low fuel level . . . . . 12, 35
- Octane rating . . . . . 256
- Recommendation . . . . . 256
- Refuelling . . . . . 259
- Reserve . . . . . 12
- Tank capacity . . . . . 322
- Unlocking the fuel filler flap by hand . . 261
- Fuel economy messages (efficiency program) . . . . . 27
- Fuse arrangement . . . . . 309
- G**
- Garage door opener (HomeLink®) . . . . . 161
- Gas discharge lamps . . . . . 312
- Gauges
- Engine coolant temperature . . . . . 10
- Fuel gauge . . . . . 12
- Speedometer . . . . . 12
- Tachometer . . . . . 11
- Trip odometer . . . . . 12
- General illustration
- Instruments and controls . . . . . 8
- General rules and driving tips . . . . . 238
- Before driving offroad . . . . . 238
- Driving offroad . . . . . 238
- Glossary of tire and loading terminology 281
- Glove compartment . . . . . 88
- Cooling box . . . . . 88
- Valet key function . . . . . 41
- Glove compartment - emergency unlocking . . . . . 88
- Glow plug system
- Indicator light . . . . . 15
- Gradient angle . . . . . 238
- Gross Vehicle Weight Rating (GVWR) . . . 320
- Ground clearance . . . . . 238
- H**
- Headlights . . . . . 57
- Adaptive light . . . . . 59
- Defective . . . . . 23
- Front fog lights . . . . . 58
- Headlight range control . . . . . 36
- Switching off . . . . . 57
- Switching on . . . . . 57
- Washer system . . . . . 66
- Xenon headlights . . . . . 57
- Headlight washer reservoir . . . . . 279
- Head restraints . . . . . 168
- Adjusting . . . . . 168
- Front seats . . . . . 76
- Rear seats . . . . . 77
- Heated
- Exterior mirrors . . . . . 68
- Front seats . . . . . 100
- Rear seats . . . . . 101
- Rear seats (four-zone automatic comfort air conditioning) . . . . . 101
- Steering wheel . . . . . 101
- Washer jets . . . . . 63
- Heating
- Climate controls . . . . . 91
- Heavy clothing and safety belts . . . . . 178
- High beam . . . . . 57, 60
- Warning/indicator lights . . . . . 18
- High voltage warning label . . . . . 320
- Hill descent control . . . . . 225

|  |     |
|--|-----|
| Hill hold  |     |
| Starting on hills  | 110 |
| HomeLink® universal remote control                             | 161 |
| Hood   |     |
| Opening  | 264 |
| Release lever  | 264 |
| Horn   | 8   |
| How are child restraint system anchors related to child safety | 218 |
| How many airbags does my vehicle have?                         | 191 |
| How often should I check my tire pressures?                    | 287 |
| How safety belt pretensioners work                             | 182 |
| Hydroplaning   | 291 |

## I

|  |        |
|--|--------|
| Ignition key                                       | 105    |
| Ignition lock                                      | 105    |
| Malfunction  | 34, 37 |
| Ignition lock positions                            | 105    |
| Important things to do before driving              | 165    |
| Improperly worn safety belts                       | 182    |
| Indicator lights                                   | 14     |
| Airbag system                                      | 195    |
| PASSENGER AIR BAG OFF                              | 195    |
| Infant seats                                       | 211    |
| Inflatable spare tire                              | 302    |
| Inflating  | 303    |
| Installing child safety seats                      |        |
| Safety belts                                       | 215    |
| Installing the upper tether strap on the anchorage | 223    |
| Instrument cluster illumination                    | 13     |
| Instruments and controls                           | 10     |
| General illustration                               | 8      |
| Interior lights                                    |        |
| Front  | 61     |
| Rear   | 61     |
| Intermittent wiping                                |        |
| Rain sensor  | 63     |

## J

|               |     |
|---------------|-----|
| Jack          | 301 |
| Jump-starting | 314 |
| Jumper cables | 315 |

## K

|  |     |
|--|-----|
| Key  | 38  |
| Battery replacement                        | 40  |
| Coded settings                             | 91  |
| Convenience opening and closing of windows | 53  |
| Emergency key                              | 38  |
| Key replacement                            | 38  |
| Master key                                 | 38  |
| Valet key                                  | 38  |
| Key coded settings                         |     |
| Climate controls                           | 91  |
| Keyless entry remote control               | 38  |
| Kick-down                                  |     |
| tiptronic®                                 | 140 |

## L

|   |          |
|---|----------|
| LATCH                                     | 218      |
| Description                               | 219      |
| Guidance fixtures for lower anchorages    | 220      |
| Installing a child restraint              | 221      |
| Location                                  | 219      |
| Mounting and releasing the anchorage hook | 221      |
| Lateral angle                             | 238      |
| Leather                                   | 252      |
| Cleaning                                  | 253      |
| Level adjustment                          |          |
| <i>refer to Adaptive Air Suspension</i>   | 155, 157 |
| Lifting jack                              | 306      |
| Lifting vehicle                           | 318      |
| Light                                     |          |
| Exterior lighting in the mirror housing   | 59       |
| leaving home                              | 59       |
| <i>also refer to Ambience lighting</i>    | 62       |
| Lighting                                  |          |
| <i>refer to Ambience lighting</i>         | 62       |
| Lighting in the mirror housing            | 59       |
| Lights                                    | 57       |
| Coming home                               | 58       |
| Daytime running lights                    | 58       |
| Emergency flashers                        | 60       |
| Exterior lights                           | 58       |
| Front fog lights                          | 58       |
| Headlights                                | 57       |
| High beam                                 | 57, 60   |

|  |     |
|--|-----|
| High beam warning/indicator light . . . . .                    | 18  |
| Leaving home . . . . .   | 58  |
| Rear fog lights . . . . .                                      | 59  |
| Side marker lights . . . . .                                   | 57  |
| Turn signals . . . . .   | 60  |
| Xenon headlights . . . . .                                     | 57  |
| Light sensor defective . . . . .                               | 35  |
| Loading the luggage compartment . . . . .                      | 171 |
| Loading the roof rack . . . . .                                | 84  |
| Locking  |     |
| Power locking switch . . . . .                                 | 44  |
| Rear lid/trunk lid . . . . .                                   | 45  |
| Remote control key . . . . .                                   | 43  |
| Using the key . . . . .  | 43  |
| Lower universal anchorage bars (Canada) . . . . .              | 218 |
| Lower universal anchorages (Canada) . . . . .                  | 218 |
| Luggage  |     |
| Stowing . . . . .  | 171 |
| luggage compartment  |     |
| Tie-down rings . . . . .                                       | 80  |
| Luggage compartment . . . . .                                  | 79  |
| Cargo net . . . . .  | 80  |
| Expanding . . . . .  | 79  |
| Retractable cover . . . . .                                    | 81  |
| Ski sack . . . . .   | 82  |
| <i>also refer to</i> Loading the luggage compartment . . . . . | 171 |

## M

|   |        |
|---|--------|
| Maintenance . . . . .                           | 325    |
| Malfunction Indicator Lamp (MIL) . . . . .      | 17, 27 |
| Master key . . . . .                            | 38     |
| Battery replacement . . . . .                   | 39, 40 |
| Check light . . . . .                           | 39     |
| Mileage   |        |
| Average . . . . .                               | 24     |
| Instantaneous . . . . .                         | 24     |
| Mirrors   |        |
| Activating the digital compass . . . . .        | 69     |
| Adjusting the exterior mirrors . . . . .        | 68     |
| dimming . . . . .                               | 69     |
| Recalling position of outside mirrors . . . . . | 73     |
| Storing position of outside mirrors . . . . .   | 73     |
| Monitoring the Advanced Airbag System . . . . . | 195    |

## N

|  |     |
|--|-----|
| Natural leather . . . . .                | 252 |
| New tires and wheels . . . . .           | 291 |
| NHTSA                                    |     |
| Contacting . . . . .                     | 172 |
| Nitrogen oxide (NOx) catalytic converter |     |
| <i>refer to</i> AdBlue . . . . .         | 261 |
| Number of seats . . . . .                | 175 |

## O

|  |     |
|--|-----|
| Occupant seating positions . . . . .                               | 166 |
| Octane rating . . . . .  | 256 |
| Odometer . . . . .   | 12  |
| Offroad mode . . . . .   | 225 |
| Oil  |     |
| <i>refer to</i> Engine oil . . . . .                               | 266 |
| On-Board Diagnostic System (OBD)                                   |     |
| Data Link Connector (DLC) . . . . .                                | 28  |
| Electronic speed limiter . . . . .                                 | 28  |
| Malfunction Indicator Lamp (MIL) . . . . .                         | 27  |
| Open door or rear lid warning . . . . .                            | 22  |
| open sky system  |     |
| <i>refer to</i> Panoramic sliding sunroof . . . . .                | 54  |
| Operate your vehicle economically and minimize pollution . . . . . | 236 |
| Optional equipment   |     |
| Marked with an asterisk . . . . .                                  | 6   |
| Other equipment (efficiency program) . . . . .                     | 27  |
| Outlets . . . . .  | 87  |
| Outside air pollution  |     |
| How to prevent from entering the vehicle . . . . .                 | 95  |
| Outside mirrors  |     |
| <i>refer to</i> Exterior mirrors . . . . .                         | 68  |
| Outside temperature display . . . . .                              | 22  |
| Owner's manual   |     |
| How the Owner's Manual is organized . . . . .                      | 6   |

## P

|                                     |     |
|-------------------------------------|-----|
| Paint                               |     |
| Touch-up . . . . .                  | 249 |
| Paint No. . . . .                   | 320 |
| Panoramic sliding sunroof . . . . . | 54  |
| closing . . . . .                   | 54  |
| Closing . . . . .                   | 55  |

- Convenience closing . . . . . 55
  - Emergency closing . . . . . 56
  - sliding open . . . . . 54
  - Sunshade . . . . . 56
  - tilting . . . . . 54
  - Parking . . . . . 110
    - Automatic transmission . . . . . 137
    - Caution when parking near a parking barrier or curb . . . . . 110
    - Low bumper cover, spoilers and suspension . . . . . 110
  - Parking brake . . . . . 109
    - Parking . . . . . 110
    - Warning/indicator lights . . . . . 19
  - Parking on a decline (downhill) . . . . . 110
  - Parking on an incline (uphill) . . . . . 110
  - Parking systems . . . . . 143
    - Adjusting the display/warning tone . . . 153
    - Audi parking system plus with front- and rearview camera . . . . . 148
    - Audi parking system plus with rearview camera . . . . . 144
    - Cleaning sensors/camera . . . . . 247
    - Malfunction . . . . . 153
    - Rear park assist . . . . . 144
    - Safety precautions . . . . . 145
    - Trailer hitch . . . . . 153
  - Particle filter
    - refer to* Diesel particulate filter . . . . . 37
  - Parts replacement . . . . . 327
  - PASSENGER AIR BAG OFF light . . . . . 195
  - Passenger's seat . . . . . 72
  - Passive safety system . . . . . 165
  - Pedals . . . . . 170
  - Perimeter lighting . . . . . 59
  - Physical principles of a frontal collision . 176
  - Polishing . . . . . 248
  - Pollen filter
    - Climate controls . . . . . 91
  - Power locking switch . . . . . 44
  - Power locking system . . . . . 41
    - Convenience close/open feature . . . . . 53
    - Locking and unlocking the vehicle from inside . . . . . 44
    - Opening and closing the windows . . . . . 53
    - Rear lid/trunk lid . . . . . 45
    - Remote control key . . . . . 38
    - Selective unlock feature . . . . . 44
    - Settings . . . . . 44
    - Unlocking and locking vehicle . . . . . 43
  - Power outlets . . . . . 87
  - Power seat
    - Controls . . . . . 72
    - Seat adjustment . . . . . 72
  - Power steering . . . . . 230
  - Power window switches . . . . . 51
    - In the driver's door . . . . . 52
    - In the front passenger's door . . . . . 53
    - Reactivating the system . . . . . 54
  - Pregnant women
    - Special considerations when wearing a safety belt . . . . . 180
  - Programming the HomeLink® universal remote control . . . . . 161
  - Proper occupant seating positions . . . . . 166
  - Proper safety belt position . . . . . 180
  - Proper seating position
    - Front passenger . . . . . 167
    - Occupants . . . . . 166
    - Rear passengers . . . . . 168
  - Protective tray . . . . . 82
- ## Q
- quattro®
    - refer to* All-wheel drive . . . . . 231
  - Question
    - What happens to unbelted occupants? 177
    - Why safety belts? . . . . . 175
- ## R
- Radiator fan . . . . . 274
  - Rain sensor . . . . . 63
  - Rain sensor defective . . . . . 35
  - Reading lights
    - Front . . . . . 61
    - Rear . . . . . 61
  - Rear ashtray . . . . . 86
  - Rear fog lights . . . . . 59
  - Rear lid
    - Automatic operation . . . . . 46
    - Emergency unlocking . . . . . 48
    - Opening and closing . . . . . 45
    - Valet key function . . . . . 41

- Rear light  
 Defective ..... 23
- Rear operation  
 Four-zone automatic comfort air conditioning ..... 100
- Rear seats  
 Adjusting seat ..... 75  
 Entry assist ..... 75  
 Folding seatback up and down ..... 76
- Rearview camera  
*refer to* Parking systems ..... 144
- Rear view mirror ..... 69
- Rear window defogger ..... 95
- Red symbols ..... 31
- Refuelling ..... 259  
 Gasoline inhibitor flap ..... 259
- Release lever for hood ..... 264
- Remote control garage door opener (HomeLink®) ..... 161
- Remote control key ..... 38  
 Unlocking and locking ..... 43
- Remote rear lid release ..... 45
- Repair manuals ..... 325
- Repairs  
 Airbag system ..... 198
- Replacing a fuse ..... 309
- Replacing light bulbs ..... 312
- Replacing tires and wheels ..... 292
- Reporting Safety Defects ..... 172, 173
- Reset button ..... 12
- Residual heat ..... 92
- Retractor ..... 179
- Rims  
 Cast alloy ..... 250
- Roof rack ..... 83  
 Loading ..... 84  
 Mounting locations ..... 84
- Roof weight ..... 84
- Rule of behavior offroad ..... 238
- S**
- Safe driving habits ..... 165
- Safety belt height adjustment ..... 181
- Safety belt position ..... 180  
 Safety belt height adjustment ..... 181  
 Safety belts worn by pregnant women . 180
- Safety belt pretensioner ..... 182  
 Service and disposal ..... 182
- Safety belts ..... 179  
 cleaning ..... 254  
 Danger to passengers who do not wear a safety belt ..... 177  
 Fastening ..... 179  
 Improperly worn ..... 182  
 Not worn ..... 177  
 Safety belt position ..... 180  
 Safety instructions ..... 178  
 Securing child safety seats ..... 215  
 Special considerations for pregnant women ..... 180  
 Unfastening ..... 181  
 Warning/indicator light ..... 175  
 Why YOU MUST wear them ..... 175  
 Worn properly ..... 177
- Safety belt warning light ..... 18, 175
- Safety compliance sticker ..... 320
- Safety equipment ..... 165
- Safety features for occupant restraint and protection ..... 165
- Safety guidelines  
 Seat adjustment ..... 71
- Safety instructions  
 Engine compartment ..... 264  
 for side curtain airbags ..... 204  
 for using child safety seats ..... 208  
 for using safety belts ..... 178  
 Monitoring the Advanced Airbag System ..... 197
- Safety lock  
 Ignition key, automatic transmission .. 105
- Safety systems  
 Warning/indicator lights ..... 16
- Seat adjustment  
 Driver's seat ..... 71  
 Driver's seat memory ..... 73  
 Front passenger's seat ..... 72  
 Front seats ..... 71  
 Head restraints ..... 76, 168  
 Power ..... 72

- Seat belts  
*refer to* Safety belts ..... 175
- Seating capacity ..... 175
- Seating position  
 Driver ..... 166  
 Front passenger ..... 167  
 How to adjust the front seats ..... 167  
 Incorrect seat position ..... 169  
 Occupants ..... 166  
 Rear passengers ..... 168
- Seat memory ..... 73
- Seats  
 Number of seats ..... 175
- Seat ventilation ..... 100
- Selective catalytic reduction  
*refer to* AdBlue ..... 261
- Selective unlock feature ..... 44
- Selector lever ..... 138
- Service and disposal  
 Safety belt pretensioner ..... 182
- Service interval display ..... 23
- Service position  
 Windshield wipers ..... 66
- Servotronic  
 Power steering ..... 230
- Shift buttons ..... 141
- Side airbags  
 Description ..... 199  
 How they work ..... 201
- Side assist  
 Activating and deactivating ..... 129  
 Cleaning sensors ..... 247  
 Description ..... 129  
 Informational and alert stage signals . 131  
 Messages in instrument cluster display 135  
 MMI settings ..... 134  
 Operation ..... 131  
 Safety tips ..... 136  
 Sensor detection area ..... 130
- Side curtain airbags  
 Description ..... 202  
 How they work ..... 203  
 Safety instructions ..... 204
- Side curtain airbags) ..... 202
- Side marker lights ..... 57
- Ski sack ..... 82
- Snow chains ..... 296
- Sockets ..... 87
- Sound system display  
 Driver information display ..... 21
- Sources of information about child restraints and their use ..... 224
- Speed control system  
*refer to* Adaptive cruise control ..... 113
- Speedometer ..... 12
- Speed rating letter code ..... 292
- Speed warning system ..... 28
- Starting on hills  
 Hill hold ..... 110
- Starting the engine ..... 105, 106  
 What should I do if the engine does not start? ..... 106
- Steering ..... 103  
 Easy entry feature ..... 104  
 Electrically adjusting the steering wheel ..... 103  
 Locking the steering ..... 105  
 Malfunction ..... 33  
 Manually adjusting the steering wheel . 103
- Steering wheel column  
 Adjusting electrically ..... 103  
 Adjusting manually ..... 103
- Steering wheel heating ..... 101
- Steps for determining correct load limit . 288
- Stopping the engine ..... 106
- Storage ..... 87  
 Cupholder ..... 85  
 Cupholder door pockets ..... 86  
 Cupholder in the rear center console ... 78  
 Cupholder rear center armrest ..... 85  
 Glove compartment ..... 88
- Storage compartment  
 Expanding ..... 79
- Storage net  
 Footwell ..... 89  
 Luggage compartment ..... 90  
 Seatbacks ..... 90
- Sunroof  
*refer to* Panoramic sliding sunroof ..... 54
- Sun shade ..... 63
- Sunshade  
 Panoramic sliding sunroof ..... 56
- Sun visors ..... 62

- Supplementary heater  
Climate controls . . . . . 100
- Suspension  
*refer to Adaptive Air Suspension . . . . .* 155, 157
- Switches  
Emergency flashers . . . . . 60  
Rear window defogger . . . . . 95
- Symbols  
Red . . . . . 31  
Yellow . . . . . 34
- Synchronization  
Climate controls . . . . . 99  
Four-zone automatic comfort air conditioning . . . . . 100
- Synchronizing climate control . . . . . 92
- T**
- Tachometer . . . . . 11
- Tank flap  
Unlocking the fuel filler flap by hand . . . . . 261
- TDI clean diesel  
*refer to AdBlue . . . . .* 261
- Technical modifications . . . . . 328
- Temperature  
Climate controls . . . . . 94  
Four-zone automatic comfort air conditioning . . . . . 98  
Setting for the driver's and front passenger's side . . . . . 94
- Tether anchors . . . . . 222
- Tether strap . . . . . 222
- The first 1,000 miles (1,500 km) and afterwards . . . . . 234
- Tie-down rings . . . . . 80
- Tie-downs . . . . . 172
- Tips for the environment  
Saving fuel . . . . . 84  
Using the air conditioner only when necessary . . . . . 97
- tiptronic® . . . . . 137  
Automatic Shift Lock (ASL) . . . . . 139  
Driving . . . . . 137  
Dynamic shift program . . . . . 140  
Emergency mode . . . . . 141  
Kick-down . . . . . 140
- Manual shift program . . . . . 140
- Selector lever . . . . . 138
- Tire pressure . . . . . 286
- Tire pressure monitoring system . . . . . 298  
Loss of air pressure . . . . . 18, 299  
Malfunction . . . . . 299  
Resetting tire pressures . . . . . 300
- Tires . . . . . 280  
Service life . . . . . 290  
speed rating letter code . . . . . 292  
Tire manufacturing date . . . . . 292  
Tire specifications . . . . . 292  
Tread depth . . . . . 290  
Uniform tire quality grading . . . . . 294  
Winter tires . . . . . 295
- Tires/Wheels  
Low aspect ratio tires . . . . . 297  
Tire pressure monitoring system . . . . . 18, 298
- Tires and vehicle load limits . . . . . 288
- Tires and wheels  
Checking tire pressure . . . . . 286  
Cold tire inflation pressure . . . . . 284  
Dimensions . . . . . 291  
General notes . . . . . 280  
Glossary of tire and loading terminology . . . . . 281  
New tires and wheels . . . . . 291  
Replacing . . . . . 292  
Snow chains . . . . . 296  
Tires and vehicle load limits . . . . . 288  
Wheel bolts . . . . . 297  
Winter tires . . . . . 295
- Tire service life . . . . . 290
- Tools . . . . . 301
- Torn or frayed safety belts . . . . . 178
- Touch-up paint . . . . . 249
- Towing  
Front eyelet . . . . . 317  
Rear eyelet . . . . . 317  
Tow truck procedures . . . . . 316
- TPMS  
Tire pressure monitoring system . . . . . 299
- Trailer towing . . . . . 241  
Operating instructions . . . . . 242  
Parking systems . . . . . 153  
Technical requirements . . . . . 241, 243

- Tongue load ..... 242
- Trailer towing tips ..... 243
- Trailer turn signal assembly  
Warning/indicator lights ..... 16
- Transmission  
tiptronic® ..... 137
- Transmission malfunction (indicator light) ..... 141
- Transport Canada ..... 173
- Tread Wear Indicator (TWI) ..... 290
- Trip computer  
Fuel consumption ..... 24  
Mileage ..... 24  
Single-trip memory ..... 25  
Total-trip memory ..... 25
- Trip odometer ..... 12  
What does it mean when dEF appears in the trip odometer display? ..... 12
- Trunk  
*refer to* Rear lid ..... 45, 46
- Turning rear air conditioning on/off  
Four-zone automatic comfort air conditioning ..... 98
- Turn signals ..... 60  
Warning/indicator lights ..... 16
- U**
- Undercoating ..... 250
- Unfastening safety belts ..... 181
- Unidirectional tires ..... 280
- Uniform tire quality grading ..... 294
- Unlocking  
Power locking switch ..... 44  
Rear lid/trunk lid ..... 45  
Remote control key ..... 43  
Using the key ..... 43
- V**
- Valet key function  
Activating and deactivating ..... 41
- Vanity mirror ..... 62
- Vehicle-care products ..... 245
- Vehicle Identification Number (VIN) ..... 320
- Vehicle jack ..... 301, 306
- Vehicle literature ..... 5
- Ventilation  
Climate controls ..... 91
- W**
- Warning/indicator lights ..... 10  
Adaptive Air Suspension ..... 17  
Adaptive cruise control ..... 121  
Airbag system ..... 16  
Anti-lock brake system (ABS) ..... 18  
Brake system ..... 19  
Cruise control ..... 18  
Electronic power control ..... 15  
Electronic Stabilization Control (ESC) ... 16  
Glow plug system ..... 15  
High beam ..... 18  
Malfunction Indicator Lamp (MIL) ..... 17  
Parking brake ..... 19  
Safety belt ..... 18  
Tire pressure monitoring system ..... 18  
Trailer turn signal assembly ..... 16  
Turn signals ..... 16
- Warning lights ..... 14
- Warranty coverages ..... 325
- Washer reservoir ..... 279
- Washing ..... 245  
Automatic car wash ..... 246  
by hand ..... 246  
General information ..... 245  
with a power washer ..... 247
- Waxing ..... 248
- Wear indicator ..... 290
- Weights ..... 320
- What happens if you wear your safety belt too loose? ..... 180
- What happens to unbelted occupants? .. 177
- What impairs driving safety? ..... 166
- What should I do after changing a wheel? ..... 287
- What should I do after replacing wheels? 287
- Wheel bolts  
Torque ..... 297
- Wheels ..... 280  
Cast alloy ..... 250  
Checking tire pressure ..... 286  
Cold tire inflation pressure ..... 284  
General notes ..... 280

|   |          |
|---|----------|
| Glossary of tire and loading terminology .....        | 281      |
| New tires and wheels .....                            | 291      |
| Tires and vehicle load limits .....                   | 288      |
| When must a safety belt be replaced? ..               | 178      |
| When must the airbag system be inspected? .....       | 195      |
| When should I adjust the tire pressures?              | 287      |
| When should I check the tire pressures? .             | 287      |
| Where are lower anchorages located? ...               | 219      |
| Where can I find the tire pressures for my car? ..... | 286      |
| Why safety belts? .....                               | 175, 176 |
| Windows   |          |
| Cleaning .....  | 249      |
| Convenience close/open feature .....                  | 53       |
| Defogging .....                                       | 94       |
| Defrosting .....                                      | 94       |
| Rapid defrosting/defogging .....                      | 96       |
| Windshield washer fluid                               |          |
| Low level .....                                       | 35       |
| Windshield wipers                                     |          |
| Changing the rear wiper blade .....                   | 67       |
| Faulty .....  | 37       |
| Intermittent wiping .....                             | 63       |
| One-tap wiping .....                                  | 63       |
| Rain sensor .....                                     | 63       |
| Rear window wiper .....                               | 65       |
| Service position .....                                | 66       |
| Washer reservoir .....                                | 279      |
| Winter operation                                      |          |
| Battery .....   | 275      |
| Coolant system .....                                  | 271      |
| Heated front seats .....                              | 100      |
| Heated rear seats .....                               | 101      |
| Steering wheel heating .....                          | 101      |
| Tires .....   | 231      |
| Windows .....   | 249      |
| Winter tires .....                                    | 295      |
| All-wheel drive .....                                 | 295      |
| Wiper blades  |          |
| Installing new wiper blades .....                     | 66       |
| <i>also refer to</i> Windshield wipers ...            | 66, 67   |

## X

|                    |     |
|--------------------|-----|
| Xenon-Lights ..... | 312 |
|--------------------|-----|

## Y

|                      |    |
|----------------------|----|
| Yellow symbols ..... | 34 |
|----------------------|----|

It has always been Audi's policy to continuously improve its products. Audi, therefore, reserves the right to make changes in design and specifications, and to make additions or improvements in its products, without incurring any obligation to install them on products previously manufactured.

Text, illustrations and specifications in this manual are based on the most up-to-date information available at the time of printing.

All rights reserved. May not be reproduced or translated in whole or in part without the

written consent of AUDI AG. Specifications are subject to change without notice.

"Audi", "quattro" and the four rings emblem are registered trademarks of AUDI AG.

**Editorial deadline: 04/20/2012**



**For the sake of the environment**

Printed on environmentally friendly paper (bleached without chlorine, recyclable).

Printed in Germany

© 2012 AUDI AG

2013 Audi Q7  
Owner's Manual  
Englisch USA 05.2012  
131.561.4L0.23



1315614L023

[www.audi.com](http://www.audi.com)