

# Owner's Manual

2018 Q5



## Foreword

Thank you for choosing an Audi - we value your trust in us.

Your new Audi will allow you to experience the best in groundbreaking technology and premium quality equipment a vehicle has to offer. We recommend that you read your Owner's Manual thoroughly so that you quickly become acquainted with your Audi and make use of all of its features.

In addition to explaining how the different features work, we provide many useful tips and information concerning your safety, how to care for your vehicle and how to maintain your vehicle's value. We also give you useful tips and information on how to drive your vehicle more efficiently and in an environmentally friendly manner.

We hope you enjoy driving your Audi and we wish you safe and pleasant motoring.

**AUDI AG**

## Table of contents

---

<b>About this Owner's Manual</b> .....	6	Start/Stop system .....	78
<b>Cockpit</b> .....	8	Electromechanical parking brake .....	80
<b>Cockpit overview</b> .....	<b>8</b>	Starting to drive .....	82
Controls at a glance .....	8	Offroad driving .....	82
Instrument cluster .....	10	Tilt angle display .....	84
Multifunction steering wheel plus .....	12	Automatic transmission .....	84
Multifunction steering wheel .....	15	<b>Trailer towing</b> .....	<b>92</b>
Vehicle functions .....	16	Driving with a trailer .....	92
Head-up display .....	18	<b>Driver assistance</b> .....	<b>95</b>
Indicator lights .....	19	<b>Assistance systems</b> .....	<b>95</b>
<b>Starting and driving</b> .....	<b>30</b>	Speed warning system .....	95
<b>Opening and closing</b> .....	<b>30</b>	Cruise control system .....	95
Central locking .....	30	Camera-based traffic sign recognition ...	97
Luggage compartment lid .....	36	Lap timer .....	98
Child safety lock .....	40	Predictive efficiency assist .....	99
Power windows .....	40	Audi adaptive cruise control .....	102
Panorama glass roof .....	42	Audi pre sense .....	112
Garage door opener (HomeLink) .....	43	Audi active lane assist .....	117
<b>Lights and Vision</b> .....	<b>45</b>	Audi side assist .....	120
Exterior lighting .....	45	Audi drive select .....	125
Interior lighting .....	48	<b>Parking aid</b> .....	<b>130</b>
Vision .....	49	General information .....	130
Windshield wipers .....	51	Rear parking system .....	131
Digital compass .....	54	Parking system plus .....	131
<b>Seats and storage</b> .....	<b>56</b>	Rearview camera .....	133
General information .....	56	Peripheral cameras .....	135
Front seats .....	56	Adjusting the parking aid .....	138
Rear seats .....	57	Error messages .....	138
Head restraints .....	58	Trailer hitch .....	139
Memory function .....	59	<b>Intelligent Technology</b> .....	<b>140</b>
Power sources .....	60	Electronic Stabilization Control (ESC) ...	140
Storage .....	60	Brakes .....	142
Luggage compartment .....	62	Electromechanical steering, Dynamic	
Roof rack .....	67	steering .....	144
<b>Warm and cold</b> .....	<b>69</b>	All-wheel drive (quattro) .....	144
Climate control system .....	69	Energy management .....	145
3 zone deluxe automatic climate control .	70	Notice about data recorded by the Event	
Steering wheel heating .....	72	Data Recorder and vehicle control	
<b>Driving</b> .....	<b>73</b>	modules .....	145
General information .....	73	<b>Infotainment system</b> .....	<b>147</b>
Steering .....	75	<b>Multi Media Interface</b> .....	<b>147</b>
Starting and stopping the engine .....	76	Traffic safety information .....	147
		Introduction .....	147

MMI On/Off knob with joystick function . . .	148	<b>Audi connect vehicle control . . . . .</b>	<b>197</b>
Infotainment system display . . . . .	148	Introduction . . . . .	197
MMI operation . . . . .	149	Setup . . . . .	197
MMI touch . . . . .	151	Additional options . . . . .	198
Control knob with joystick function . . . . .	153	Remote locking and unlocking . . . . .	198
Shortcut keys . . . . .	155	Vehicle status report . . . . .	198
Letter/number speller . . . . .	155	Parking location . . . . .	198
Free text search . . . . .	157	Geofencing Alert . . . . .	199
Menus and Symbols . . . . .	158	Speed Alert . . . . .	199
		Valet Alert . . . . .	199
<b>Multifunction steering wheel . . . . .</b>	<b>160</b>	Stolen Vehicle Locator . . . . .	199
Introduction . . . . .	160	Online Audi service request . . . . .	199
Radio . . . . .	160		
Media . . . . .	160	<b>Emergency call . . . . .</b>	<b>201</b>
Telephone . . . . .	161	Introduction . . . . .	201
Navigation . . . . .	162	Emergency call . . . . .	201
		Online roadside assistance . . . . .	202
<b>Voice recognition system . . . . .</b>	<b>167</b>		
Operating . . . . .	166	<b>Navigation . . . . .</b>	<b>203</b>
Command overview information . . . . .	167	Opening navigation . . . . .	203
Commands . . . . .	168	Entering a destination . . . . .	204
External voice operation . . . . .	172	Personal route assistance . . . . .	209
		Alternative routes . . . . .	210
<b>Telephone . . . . .</b>	<b>174</b>	Additional settings . . . . .	210
Introduction . . . . .	174	Map . . . . .	213
Setup . . . . .	174	Satellite map . . . . .	215
Using the telephone . . . . .	177	Map update . . . . .	216
Favorites . . . . .	179	Traffic information . . . . .	217
Messages . . . . .	180	Troubleshooting . . . . .	219
Listening to voicemail . . . . .	182		
Directory . . . . .	183	<b>Radio . . . . .</b>	<b>220</b>
Additional settings . . . . .	184	Opening the radio . . . . .	220
Troubleshooting . . . . .	186	Radio functions . . . . .	221
		Radio menu . . . . .	223
<b>Audi connect (Infotainment) . . . . .</b>	<b>187</b>	Presets . . . . .	223
Introduction . . . . .	187	Additional settings . . . . .	223
Setup . . . . .	187	Troubleshooting . . . . .	224
Configuration through myAudi . . . . .	187		
Opening Audi connect (Infotainment) . . . . .	188	<b>Media . . . . .</b>	<b>225</b>
Audi connect Infotainment services . . . . .	188	Introduction . . . . .	225
Wi-Fi hotspot . . . . .	193	Notes . . . . .	225
Configuring the data connection . . . . .	194	Media drives . . . . .	226
Audi connect (Infotainment) general		Bluetooth audio player . . . . .	228
information . . . . .	194	Wi-Fi audio player . . . . .	229
Troubleshooting . . . . .	196	Online media and Internet radio . . . . .	230
		Multimedia connections . . . . .	231
		Playing media . . . . .	234
		Additional settings . . . . .	237

## Table of contents

---

Supported media and file formats . . . . .	240	<b>Maintenance and Care . . . . .</b>	<b>310</b>
Troubleshooting . . . . .	241	<b>Checking and Filling . . . . .</b>	<b>310</b>
<b>Audi smartphone interface . . . . .</b>	<b>243</b>	Fuel . . . . .	310
Setup . . . . .	243	Refueling . . . . .	311
Operating . . . . .	243	Emissions control system . . . . .	313
Troubleshooting . . . . .	244	On Board Diagnostic System (OBD) . . . . .	313
<b>System settings . . . . .</b>	<b>245</b>	Engine compartment . . . . .	314
Setting the date and time . . . . .	245	Engine oil . . . . .	317
MMI settings . . . . .	245	Cooling system . . . . .	319
Connection manager . . . . .	246	Brake fluid . . . . .	321
System update . . . . .	248	Battery . . . . .	321
Sound settings . . . . .	249	Windshield washer system . . . . .	323
Volume settings . . . . .	249	Service interval display . . . . .	324
Restarting the MMI . . . . .	250	<b>Wheels . . . . .</b>	<b>325</b>
Software license information . . . . .	250	Wheels and Tires . . . . .	325
<b>Safety first . . . . .</b>	<b>252</b>	Tire pressure monitoring system . . . . .	342
<b>Driving safety . . . . .</b>	<b>252</b>	<b>Care and cleaning . . . . .</b>	<b>344</b>
Basics . . . . .	252	General information . . . . .	344
Correct passenger seating positions . . . . .	253	Car washes . . . . .	344
Pedal area . . . . .	256	Cleaning and care information . . . . .	345
Storing cargo correctly . . . . .	257	Placing your vehicle out of service . . . . .	349
Reporting Safety Defects . . . . .	259	<b>Troubleshooting . . . . .</b>	<b>350</b>
<b>Safety belts . . . . .</b>	<b>261</b>	<b>Emergency assistance . . . . .</b>	<b>350</b>
General information . . . . .	261	General information . . . . .	350
Why use safety belts? . . . . .	262	Equipment . . . . .	350
Safety belts . . . . .	264	Tire mobility kit . . . . .	350
Belt tensioners . . . . .	267	Replacing a wheel . . . . .	352
<b>Airbag system . . . . .</b>	<b>269</b>	Collapsible spare tire . . . . .	356
Important information . . . . .	269	<b>Fuses and bulbs . . . . .</b>	<b>358</b>
Front airbags . . . . .	273	Fuses . . . . .	358
Monitoring the Advanced Airbag System . . . . .	281	Bulbs . . . . .	362
Side airbags . . . . .	285	<b>Emergency situations . . . . .</b>	<b>363</b>
Side curtain airbags . . . . .	288	General . . . . .	363
<b>Child safety . . . . .</b>	<b>291</b>	Starting by pushing or towing . . . . .	363
Important information . . . . .	291	Starting with jumper cables . . . . .	363
Child safety seats . . . . .	297	Using the jump start cable . . . . .	364
Securing child safety seats . . . . .	302	Towing with a tow truck . . . . .	365
LATCH system (lower anchorages and tethers for children) . . . . .	305	Raising the vehicle . . . . .	367
Additional information . . . . .	309	<b>Accessories and Technical Data . . . . .</b>	<b>369</b>
		<b>Technical data . . . . .</b>	<b>369</b>
		Vehicle specifications . . . . .	369
		Notes about technical data . . . . .	369

---

Dimensions . . . . .	369
Capacities . . . . .	369
Weights . . . . .	370
<b>Consumer Information . . . . .</b>	<b>371</b>
Warranty coverages . . . . .	371
Operating your vehicle outside the U.S.A. or Canada . . . . .	371
Audi Service Repair Manuals and Literature . . . . .	371
Maintenance . . . . .	371
Accessories and technical changes . . . . .	373
Declaration of compliance for telecommunications equipment and electronic systems . . . . .	374
<b>Index . . . . .</b>	<b>375</b>

## About this Owner's Manual

---

This Owner's Manual applies to all versions of this model. It contains important information, tips, suggestions and warnings for using your vehicle.

Keep this manual in your vehicle at all times. This is especially important if you loan your vehicle to others or sell it.

This owner's manual describes the **equipment range** specified for this model at the time of printing. Individual equipment options described may only be available at a later date or may only be offered in certain countries.

Some sections in this manual do not apply to all vehicles. When this is the case, the beginning of the section indicates the **validity**, for example "Applies to vehicles: with cruise control system". Optional or vehicle-specific equipment is also identified with an asterisk "\*".

The **illustrations** in this manual are a guide. Some of the details in your vehicle may differ from the illustration.

All **directions**, such as "left", "right", "front" and "rear", are based on the vehicle's direction of travel.

\* Optional or vehicle-specific equipment

▶ The section continues on the next page.

⇒ ⚠ Cross reference to a "WARNING" within a section. If a page number is indicated, the WARNING is located outside of the section.

### **WARNING**

Text with this symbol contains information about safety and how to reduce the risk of serious personal injury or death.

### **Note**

Text with this symbol contains information about reducing the risk of damage to your vehicle.

### **For the sake of the environment**

Text with this symbol contains information on protecting the environment.

### **Tips**

Text with this symbol contains additional useful information.



# Cockpit overview

## Controls at a glance

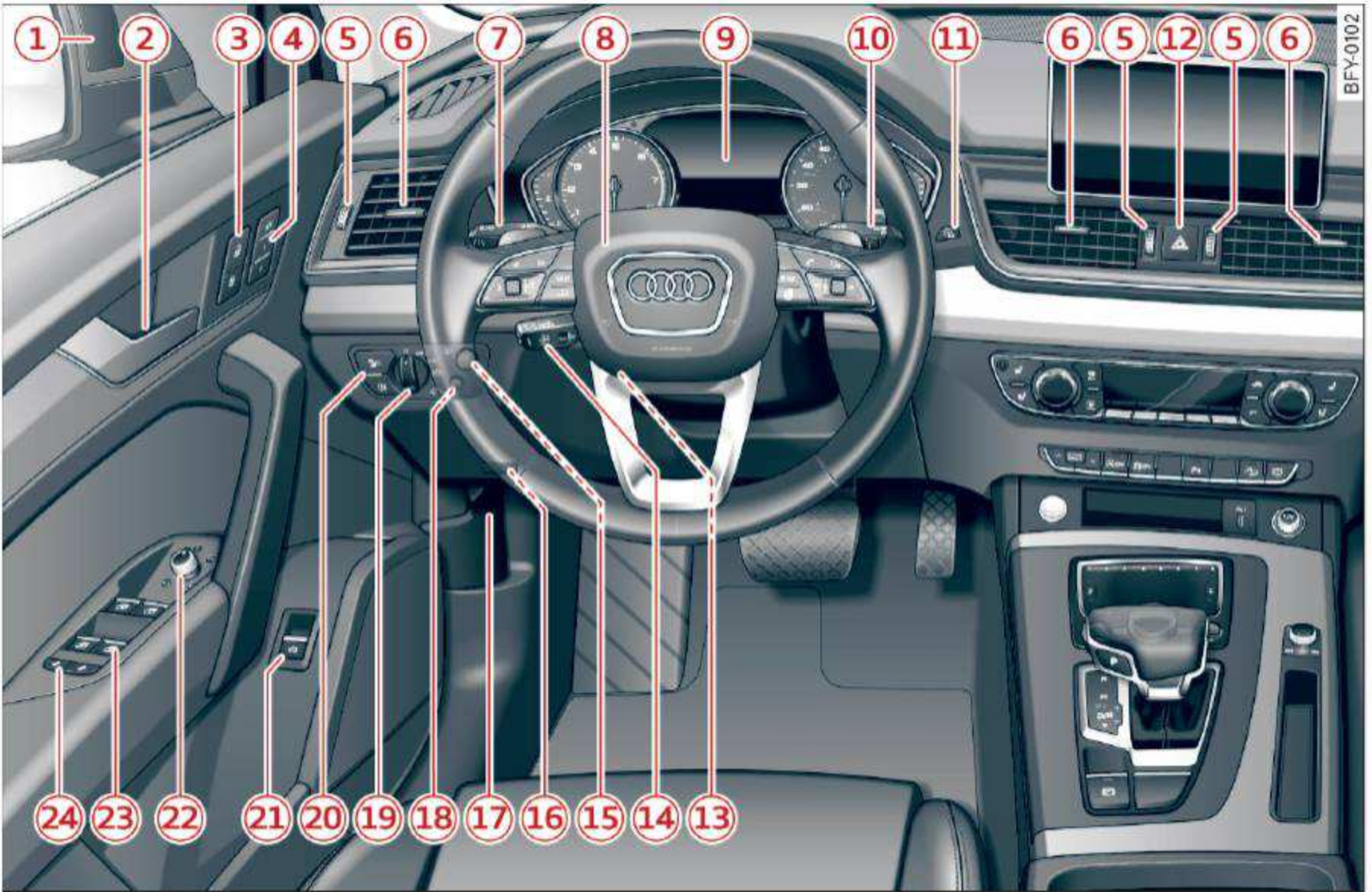

Fig. 1 Cockpit: left section

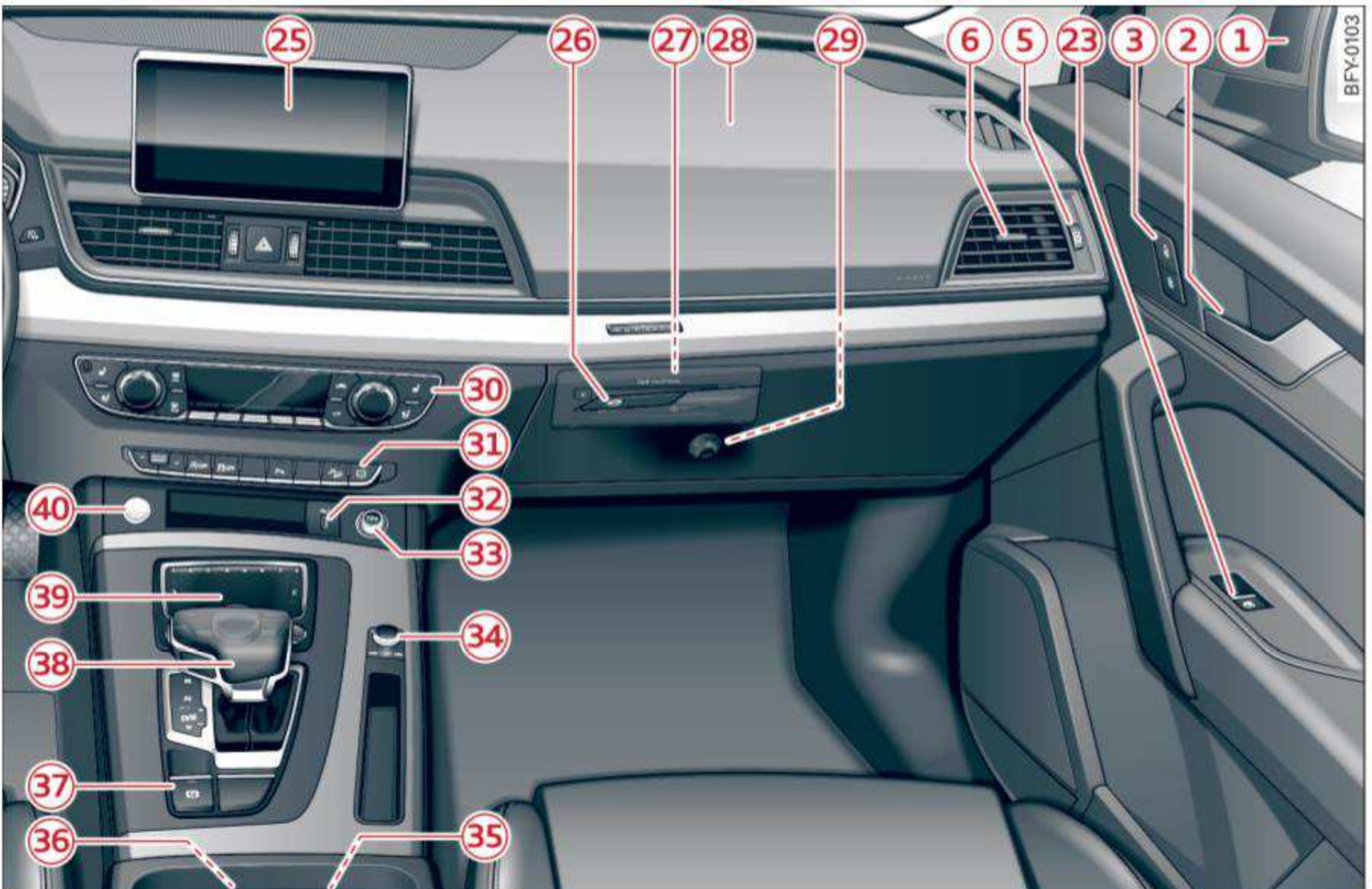

Fig. 2 Cockpit: right section

①	side assist displays, warning about exiting the vehicle	120	– Rear fog lights	45	
②	Door handle		②①	Switch for luggage compartment lid	36
③	Central locking switch	34	②②	Power exterior mirror adjustment	49
④	Memory buttons	59	②③	Power windows	40
⑤	Thumbwheel for vent		②④	Child safety lock	40
⑥	Vent		②⑤	Infotainment system display	148
⑦	Lever for:		②⑥	Lockable glove compartment	61
	– Turn signals and high beams	46	②⑦	Drives for CD, DVD, SIM cards	226
	– High beam assistant	46	②⑧	Front passenger's airbag	273
	– Active lane assist	117	②⑨	Switch for cooled glove compartment	61
	– Traffic jam assist	109	③⑩	Climate control system	69
⑧	Multifunction steering wheel with:		③①	Depending on equipment, buttons for:	
	– Horn			– drive select	125
	– Driver's airbag	273		– Start/Stop system	78
	– Driver information system controls	12, 15		– Electronic Stabilization Control (ESC)	141
	– Audio/video, telephone, navigation and voice recognition controls	14, 15		– Parking system	130
	– /steering wheel heating button	14		– Hill hold assist	142
	– Shift paddles	88		– Infotainment system display	148
⑨	Instrument cluster	10	③②	Audi music interface	232
⑩	Windshield washer system lever	51	③③	Socket	60
⑪	Reset trip odometer	12	③④	Infotainment system on/off button	148
⑫	Emergency flashers	47	③⑤	Center armrest with storage compartment. Depending on vehicle equipment, it may have:	
⑬	Steering wheel adjustment, depending on equipment			– Cup holder	60
	– Mechanical	75		– Audi music interface	232
	– Power	75	③⑥	Starting the engine if there is a malfunction	78
⑭	Lever for:		③⑦	Electromechanical parking brake	80
	– Cruise control system	95	③⑧	Automatic transmission selector lever	84
	– Adaptive cruise control	102	③⑨	Infotainment system unit	147
⑮	Button for switching the head-up display on/off, adjusting the height	18	④⑩	button	76
⑯	Data link connector for On-Board Diagnostic System (OBD II)	314			
⑰	Hood release	315			
⑱	Instrument illumination	49			
⑲	Headlight control switch	45			
⑳	Buttons for:				
	– All-weather lights	45			

**i Tips**  
 Some the equipment listed here is only installed in certain models or is available as an option.

# Instrument cluster

## Instrument cluster overview

The instrument cluster is the central information center for the driver.



Fig. 3 Instrument cluster overview (analog)

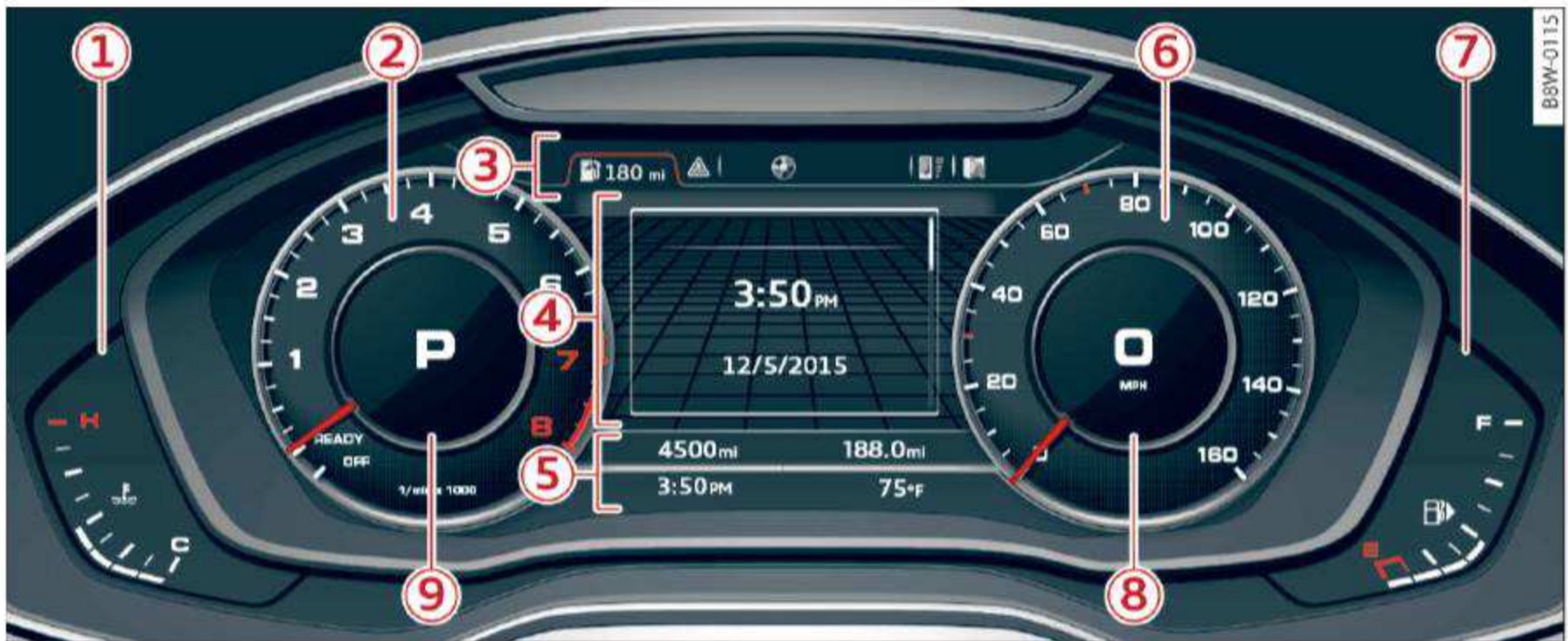

Fig. 4 Instrument cluster overview (Audi virtual cockpit)

- ① Engine coolant temperature gauge .. 11
- ② Tachometer ..... 11
  - with **OFF** status indicator ..... 76
  - with **READY** status indicator ... 76, 78
- ③ Tab area ..... 12
- ④ Central area with
  - Driver information system ..... 12, 15
  - Indicator lights ..... 19
- ⑤ Status line (displayed on one or two lines)
- ⑥ Speedometer/convenience display
- ⑦ Fuel level ..... 12

- ⑧ Speedometer
- ⑨ Left additional display (divided in two sections in the enhanced view)

There may be additional indicator lights in the tachometer ②, the speedometer ⑥, the status line ⑤ and, depending on the instrument cluster, above or below the central area ④.

The following pages will primarily show illustrations of the multi-color analog instrument cluster\*. The display and/or position of the element shown may vary in monochrome instrument clusters or in the Audi virtual cockpit\*.

Certain instrument cluster content can also be displayed in the head-up display\* ⇒ *page 18*.

### **WARNING**

Do not assume the roads are free of ice based on the outside temperature display. Be aware that there may be ice on roads even when the outside temperature is around 41 °F (+5 °C) and that ice can increase the risk of accidents.

### **Tips**

- Depending on vehicle equipment, the instrument illumination (needles and gauges) may turn on when the lights are off and the ignition is switched on. The illumination for the gauges reduces automatically and eventually turns off as brightness outside increases. This function reminds the driver to turn the low beams on at the appropriate time.
- You can select the units used for temperature, speed and other measurements in the Infotainment system ⇒ *page 245*.
- If your vehicle is stationary or if you are driving at very low speeds, the temperature displayed may be slightly higher than the actual temperature outside due to the heat radiating from the engine.
- At temperatures below 41 °F (+5 °C), a snowflake symbol appears in front of the temperature display ⇒ .

## Coolant temperature indicator

The coolant temperature display  ⇒ *page 10, fig. 3* or ⇒ *page 10, fig. 4* only functions when the ignition is switched on. To prevent engine damage, please observe the following notes about the temperature ranges.

### Cold range

If only the LEDs at the bottom of the gauge turn on, the engine has not reached operating temperature yet. Avoid high engine speeds, full acceleration and heavy engine loads.

### Normal range

The engine has reached its operating temperature once the LEDs up to the center of the gauge turn on. If the  indicator light in the instrument cluster display turns on, the coolant temperature is too high ⇒ *page 23*.

### **Note**

- Auxiliary headlights and other accessories in front of the cooling-air intake impair the cooling effect of the coolant. This increases the risk of the engine overheating during high outside temperatures and heavy engine load.
- The front spoiler also helps to distribute cooling air correctly while driving. If the spoiler is damaged, the cooling effect will be impaired and the risk of the engine overheating will increase. See an authorized Audi dealer or authorized Audi Service Facility for assistance.

## Tachometer

*The tachometer displays the engine speed in revolutions per minute (RPM).*

The beginning of the red zone in the tachometer indicates the maximum permissible engine speed for all gears once the engine has been broken in and when it is warmed up to operating temperature. Before reaching this zone, you should shift into the next highest gear, select the "D/S" selector lever position, or remove your foot from the accelerator pedal.

### **Note**

The needle in the tachometer  ⇒ *page 10, fig. 3* or ⇒ *page 10, fig. 4* may only be in the red area of the gauge for a short time or there is a risk of engine damage. The location where the red zone begins varies depending on the engine.

### **For the sake of the environment**

Upshifting early helps you to save fuel and reduces operating noise.

**Fuel level**

The display ⑦ ⇒ page 10, fig. 3 or ⇒ page 10, fig. 4 only functions when the ignition is switched on. When the display has reached the reserve mark, a red LED turns on and the  indicator light turns on ⇒ page 27. The red LED will blink when the fuel level is very low.

For the tank capacity in your vehicle, refer to the Technical Data ⇒ page 369.

**Note**

Never drive until the tank is completely empty. The irregular supply of fuel that results from that can cause engine misfires. Uncombusted fuel will then enter the exhaust system. This can cause overheating and damage to the catalytic converter.

**Odometer**



Fig. 5 Instrument cluster: odometer and reset button

**Trip odometer and odometer**

The trip odometer shows the distance driven since it was last reset. It can be used to measure short distances.

The trip odometer can be reset to zero by pressing the  reset button.

The odometer shows the total distance that the vehicle has been driven.

**Malfunction indicator**

If there is a malfunction in the instrument cluster, **DEF** will appear in the trip odometer display. Have the malfunction corrected as soon as possible.

**Tips**

The units of measurement can be set in the Infotainment system ⇒ page 245.

**Multifunction steering wheel plus**

**Operating**

Applies to: vehicles with multifunction steering wheel plus



Fig. 6 Driver information system display

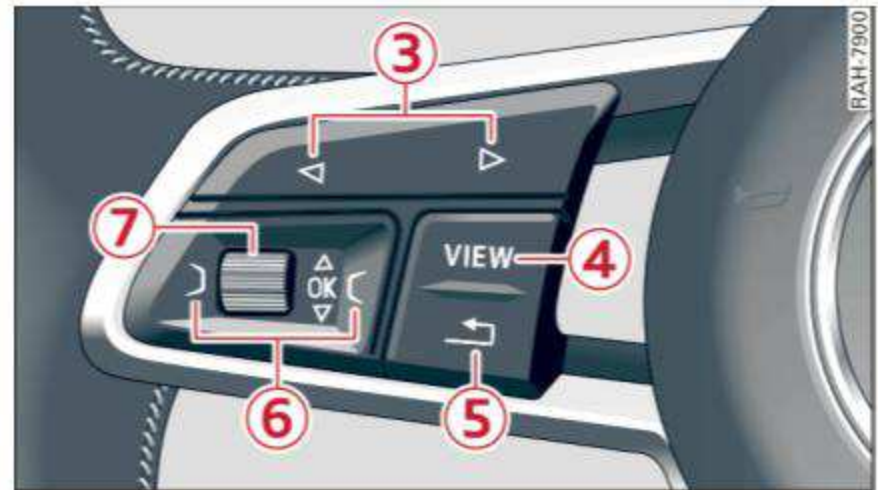

Fig. 7 Left side of multifunction steering wheel

Requirement: the ignition must be switched on.

The driver information system contains multiple tabs ① ⇒ fig. 6 that display various information ②.

The following tabs are available, depending on vehicle equipment:

First tab	Vehicle functions ⇒ page 16
Second tab <sup>a)</sup>	Messages
Third tab	Radio ⇒ page 160 Media ⇒ page 160

Fourth tab	Telephone* ⇒ page 161
Fifth tab	Navigation* ⇒ page 162 Map* ⇒ page 163

a) This tab is only visible when there is at least one indicator light or message displayed.

### ③ ◀▶ Button

– **Switching tabs:** press the ◀▶ button repeatedly until the desired tab is shown (for example, Radio).

### ④ VIEW button

Switching views or reducing the display  
⇒ page 14.

### ⑤ ↶ Button

Return to functions at higher levels.

### ⑥ ] and [ control buttons

Open/close the selection menu or options menu  
⇒ page 13.

### ⑦ Left thumbwheel

- **Selecting a function in a menu/list:** turn the left thumbwheel to the desired function (for example, selecting a frequency).
- **Confirming a selection:** press the left thumbwheel ⑦ ⇒ fig. 7.
- **Zooming in/out on the map:** when a map is displayed, turn the left thumbwheel to zoom in and out on the map.

## Control buttons

Applies to: vehicles with multifunction steering wheel plus

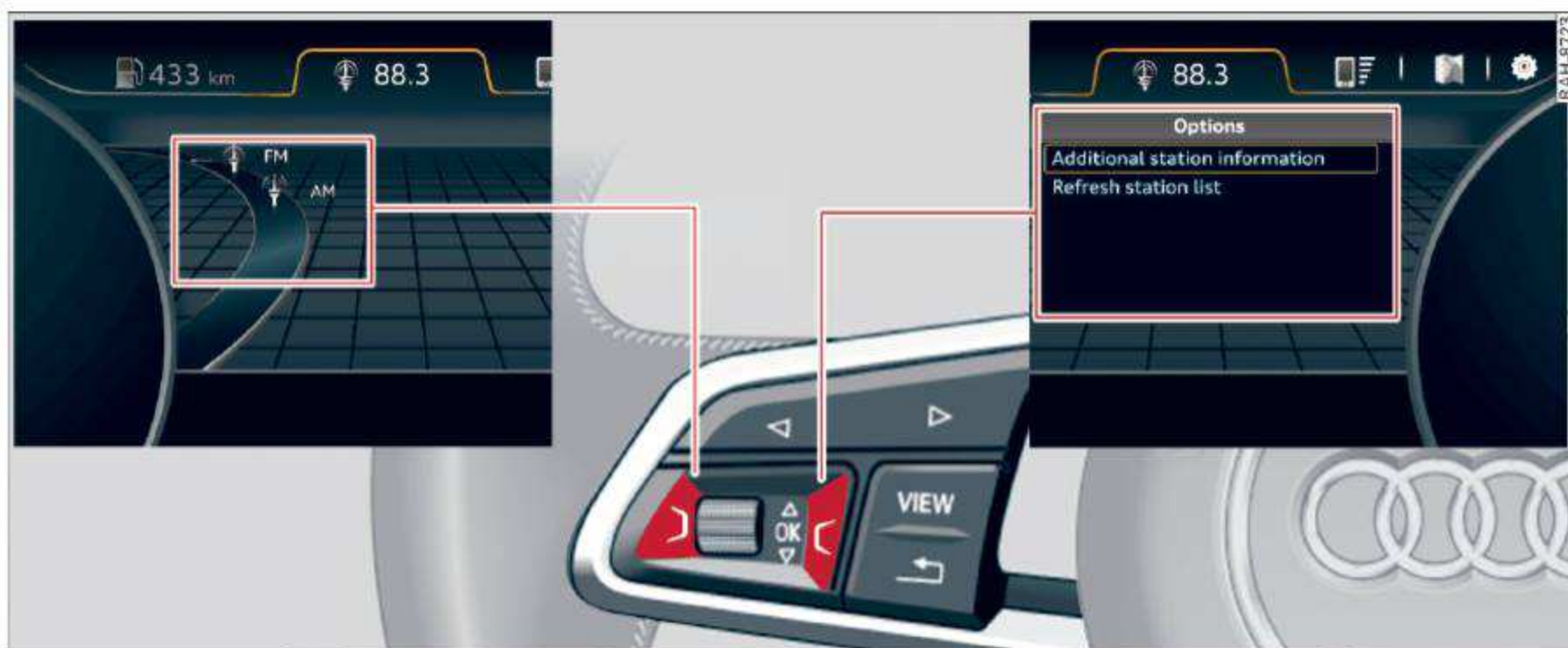

Fig. 8 Selection menu and options menu view

### Left control button

– **Opening/closing the selection menu:** press the respective left control button on the steering wheel ⇒ fig. 8. You can select and confirm a function in the selection menu using the left thumbwheel (for example, selecting a frequency band).

### Right control button

– **Opening/closing the options menu:** press the respective right control button on the steering

wheel ⇒ fig. 8. You can change any context-dependent functions and settings using the left thumbwheel (for example, additional station information).

### **i** Tips

The availability of a selection menu or options menu depends on the function that is selected.

## Switching views

Applies to: vehicles with multifunction steering wheel plus



Applies to: vehicles with Audi virtual cockpit

Fig. 9 Default view: classic/sport\*



Applies to: vehicles with Audi virtual cockpit

Fig. 10 Enhanced view

## Change view

Applies to: vehicles with Audi virtual cockpit

- ▶ Press the **VIEW** button (4) ⇒ page 12, fig. 7 to switch from the default view ⇒ fig. 9 to the enhanced view ⇒ fig. 10. To return to the default view, press the **VIEW** button again.

## Setting the default view

Applies to: vehicles with sport view

Depending on the vehicle equipment, you can choose between the classic and the sport view.

- ▶ Open the first vehicle functions tab using the **◀▶** button on the multifunction steering wheel.

- ▶ Select on the multifunction steering wheel: left control button > **Layout** > **Sport layout** or **Classic layout**.

## Reducing the display

Applies to: vehicles with analog instrument cluster

- ▶ Press the **VIEW** button to switch from the classic to the reduced display. To return to the classic view, press the **VIEW** button again.

## Adjusting the additional display

Applies to: vehicles with Audi virtual cockpit

Depending on the vehicle equipment, the additional displays that can be selected may vary.

- ▶ Open the first vehicle functions tab using the **◀▶** button on the multifunction steering wheel.
- ▶ On the multifunction steering wheel, select the right control button > **Additional display**.
- ▶ Select the desired additional display.

## **i** Tips

Applies to: vehicles with sport view

Always set the desired default view before driving, because the display functions will not be available for several seconds.

## Other function buttons

Applies to: vehicles with multifunction steering wheel plus

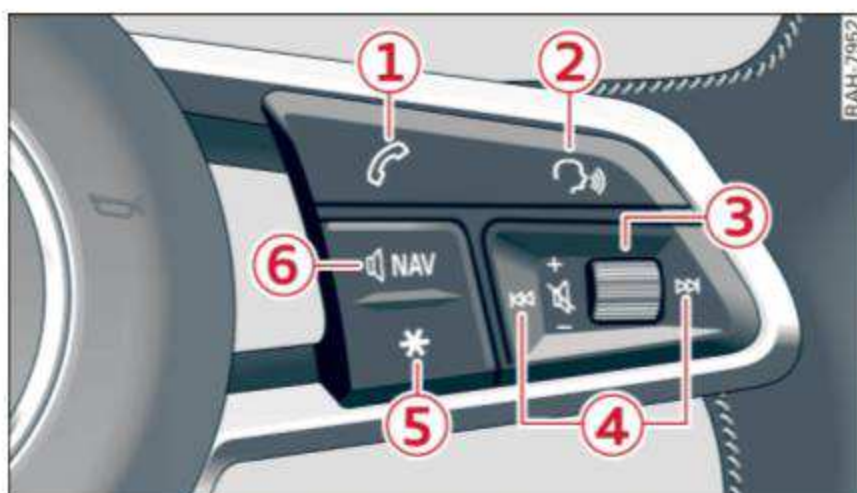





Fig. 11 Right side of the multifunction steering wheel

### **1** Button

- **Accepting a call:** press the button when there is an incoming call.
- **Ending a call:** press the button during a phone call to end the call.

- **Opening the call list:** if no phone call is in progress and there are no incoming calls, press the  button.

## ② Button

- **Switching the voice recognition system on:** briefly press the  button. Say the desired command after the **Beep**.
- **Switching the voice recognition system off:** press and hold the  button. **Or:** say the command **Cancel**.

For more information about the voice recognition system, see ⇒ page 167, *Voice recognition system* or ⇒ page 245.

## ③ Right thumbwheel

You can adjust the volume of an audio source or a system message (for example, from the voice recognition system) when the sound is playing.

- **Increasing or decreasing the volume:** turn the right thumbwheel up or down.
- **Muting or pausing:** turn the right thumbwheel down. **Or:** press the right thumbwheel.
- **Unmuting or resuming:** turn the right thumbwheel up. **Or:** press the right thumbwheel.

## ④ / Button

- **Selecting the previous/next track or station:** press the  or  button.
- **Fast forwarding/rewinding audio files:** press and hold the  or  button until the desired location in the file is reached.

## ⑤ / Steering wheel heating button

- **Steering wheel heating\*:** you can find additional information in ⇒ page 72.
- **Programmable steering wheel button - opening a function:** press the  button on the multifunction steering wheel.
- **Programmable steering wheel button - requesting a function:** press and hold the  button.
- **Programmable steering wheel button - changing a function:** press and hold the  button. Select and confirm an entry. **Or**

- Select in the Infotainment system: **MENU** button > **Vehicle** > left control button > **Vehicle settings** > **Steering wheel button assignment**.

## ⑥ Button

- **Repeating the last navigation prompt:** press the  button when route guidance is active.
- **Changing the voice guidance volume:** when route guidance is active, turn the right thumbwheel upward or downward during a navigation prompt.

## Multifunction steering wheel

### Operating

Applies to: vehicles with multifunction steering wheel

*With the multifunction steering wheel, you can operate the driver information system as well as the MMI functions and you can also adjust the volume.*

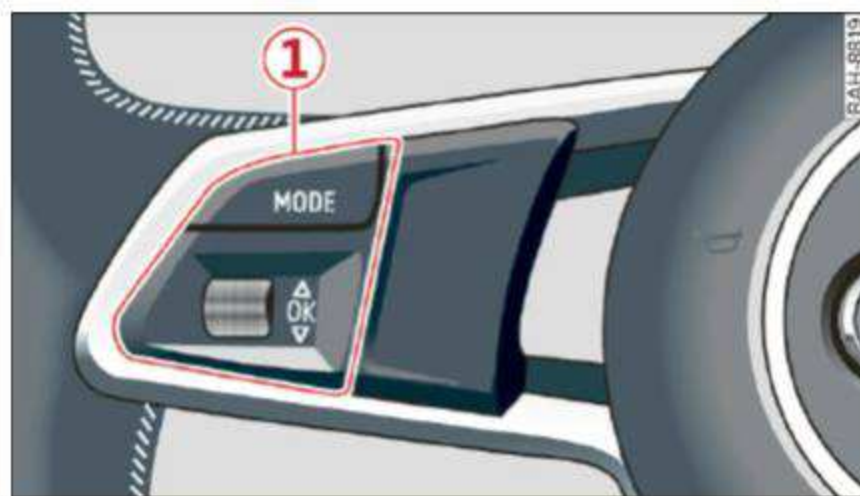

Fig. 12 Left side of multifunction steering wheel

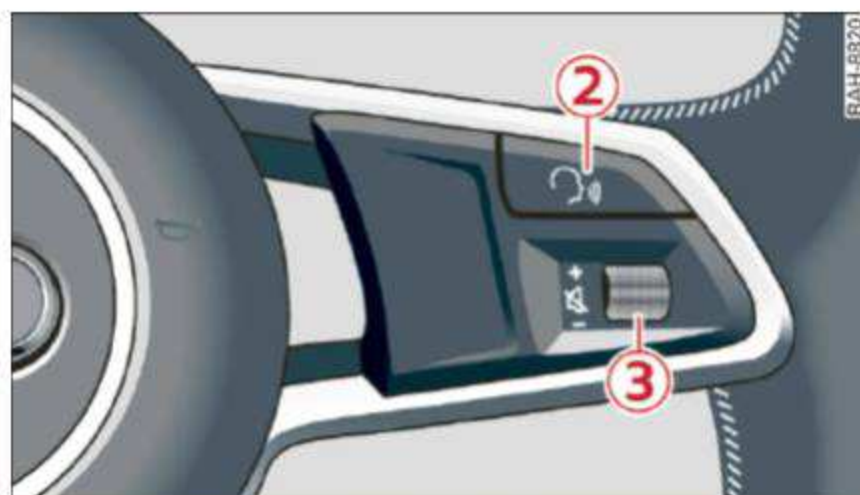

Fig. 13 Right side of the multifunction steering wheel

Requirement: the ignition must be switched on. ►

### ① Operating the driver information system

The driver information system contains multiple tabs ① ⇒ page 12, fig. 6 that display various information ② ⇒ page 12, fig. 6.



The following tabs are available, depending on vehicle equipment:

First tab	On-board computer ⇒ page 16
Second tab <sup>a)</sup>	Messages
Third tab	Radio ⇒ page 160 Media ⇒ page 160
Fourth tab	Telephone ⇒ page 161

a) This tab is only visible when there is at least one indicator light or message displayed.

- **Switching tabs:** press the **MODE** button ⇒ fig. 12 on the multifunction steering wheel repeatedly until the desired tab is displayed.
- **Selecting a function in the menu/list:** turn the left thumbwheel on the multifunction steering wheel to the desired function.
- **Confirming a selection:** press the left thumbwheel on the multifunction steering wheel to confirm your selection.
- **Scrolling within the lists:** turn the left thumbwheel on the multifunction steering wheel quickly to scroll within the lists.

### ② Button

- **Switching the voice recognition system on:** briefly press the  button ⇒ fig. 13. Say the desired command after the **Beep**.
- **Switching the voice recognition system off:** press and hold the  button. **Or:** say the command **Cancel**.

For more information about the voice recognition system, see ⇒ page 167, *Voice recognition system* or ⇒ page 245.

### ③ Right thumbwheel

The volume of an audio source or a system message (such as traffic announcements) can be directly adjusted during the audio output.

- **Increasing or decreasing the volume:** turn the right thumbwheel ⇒ fig. 13 up or down.

- **Muting or pausing:** turn the right thumbwheel down. **Or:** press the right thumbwheel.
- **Unmuting or resuming:** turn the right thumbwheel upward. **Or:** press the right thumbwheel.

## Vehicle functions

### Overview

The trip computer is displayed in the first tab of the driver information system. Additional vehicle functions can be accessed depending on the vehicle equipment.

- ▶ Press the left control button.

- On-board computer ⇒ page 16
- Lap times ⇒ page 98
- Statistics ⇒ page 99
- Layout ⇒ page 14

### Trip computer



Fig. 14 Instrument cluster: fuel consumption display

### Resetting values to zero

Requirement: the **Fuel consumption**, **Short-term memory** or **Long-term memory** display must be selected.

- ▶ To reset the values in the respective memory to zero, press and hold the left thumbwheel on the multifunction steering wheel for one second. **Or**
- ▶ On the multifunction steering wheel, select: the right control button > **Reset values\***.

In the trip computer, you can call up the following displays one after the other by turning the left thumbwheel on the multifunction steering wheel.

- Time and date ⇒ *page 245*
- Digital speedometer\*
- Average consumption
- Remaining range\*
- Short-term memory overview
- Long-term memory overview
- Energy consumers\* ⇒ *page 17*
- Driver assistance\* ⇒ *page 102*
- Traffic sign recognition\* ⇒ *page 97*

The short-term memory collects driving information from the time the ignition is switched on until it is switched off. If you continue driving within two hours after switching the ignition off, the new values are included when calculating the current trip information.

Unlike the short-term memory, the long-term memory is not erased automatically. You can select the time period for evaluating trip information yourself.

### Fuel consumption

The current fuel consumption can be shown using a bar graph ⇒ *fig. 14*. The average consumption stored in the short-term memory is also displayed. If the bars are green or the gray tone on the bars changes (depending on the equipment), your vehicle is saving fuel by the following function:

- **Recuperation:** electrical energy can be stored in the vehicle battery when the vehicle is coasting or driving downhill. The bar will move toward .

### Tips

The date, time of day and time and date format can be set in the Infotainment system ⇒ *page 245*.

### Energy consumers

Applies to: vehicles with energy consumers

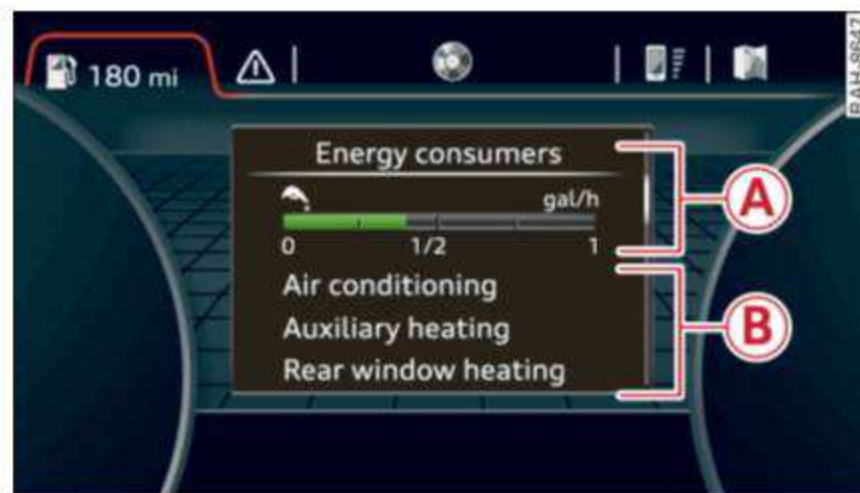

Fig. 15 Instrument cluster: energy consumers

In the **Energy consumers** view, the other equipment that is currently affecting fuel consumption is listed in the first tab (on-board computer). The display shows up to three energy consumers **B** ⇒ *fig. 15*. The equipment using the most power is listed first. If more than three items using power are switched on, the equipment that is currently using the most power is displayed.

A gauge **A** also shows the current total consumption of all other consumers.

### Engine oil temperature display and boost indicator

Applies to: vehicles with engine oil temperature display/boost indicator

Applies to: vehicles with analog instrument cluster

The engine oil temperature and boost indicator are only shown in the lap timer display ⇒ *page 98*.



### Engine oil temperature indicator

Applies to: vehicles with Audi virtual cockpit

The engine oil temperature is only shown in the enhanced view or in the sport view ⇒ *page 14*.

When engine oil temperatures are low, the display --- °F (--- °C) appears in the instrument cluster.

The engine has reached its operating temperature when the engine oil temperature is between 176 °F (80 °C) and 248 °F (120 °C) under normal driving conditions. The engine oil temperature

may be higher if there is heavy engine load and high temperatures outside. This is not a cause for concern as long as the  ⇒ *page 24* or  ⇒ *page 24* indicator lights do not turn on.

### Boost indicator

Applies to: vehicles with Audi virtual cockpit

The boost indicator is only displayed in the sport view ⇒ *page 14*.

The current engine load (meaning the current boost pressure) is indicated by a bar.

## Head-up display



Applies to: vehicles with head-up display



Fig. 16 Instrument panel: knob for the head-up display

The head-up display projects certain warnings or selected information from the assist systems\* or navigation\* on the windshield. The display appears within the driver's field of vision.

### Switching on/off

- ▶ To switch the head-up display on, press the  knob.
- ▶ To switch the head-up display off, press the  knob.

### Adjusting the height

The height of the display can be adjusted to the individual driver.

- ▶ Make sure you are seated correctly ⇒ *page 253*.
- ▶ Turn the knob  to adjust the display.

## Settings in the Infotainment system

- ▶ Select in the Infotainment system: **MENU** button > **Vehicle** > left control button > **Driver assistance** > **Head-up display**.

### Display content

In the Infotainment system, you can specify which information should be displayed: For example, this can include navigation information\*, adaptive cruise control\* or camera-based traffic sign recognition\*.

The display of certain information and some of the red indicator lights cannot be hidden in the Infotainment system.

### Brightness

You can adjust the display brightness in the Infotainment system. The display brightness decreases automatically as the amount of light decreases. The background brightness is adjusted with the instrument illumination ⇒ *page 49*.

### Picture rotation

You can rotate the picture in the Infotainment system clockwise or counterclockwise.

#### Note

To prevent scratches on the glass covering the head-up display, do not place any objects in the projection opening.

#### Tips

- Sunglasses with polarization filters and unfavorable lighting conditions can have a negative effect on the display.
- An optimum display depends on the seat position and the height adjustment of the head-up display.
- A special windshield is needed for the head-up display function.
- For information on cleaning, see ⇒ *table Interior cleaning on page 346*.

## Indicator lights

### Description

The indicator lights in the instrument cluster blink or turn on. They indicate functions or malfunctions.

Messages may appear with some indicator lights. A warning signal will sound at the same time. The indicator lights and messages in the instrument cluster display can be covered by other displays. To show them again, select the second tab with the multifunction steering wheel ⇒ *page 12*. If there are several malfunctions, you can display them one at a time using the thumbwheel.



Some indicator lights in the display can display in several colors.

### ⚠ Central indicator light

If the  or  indicator light turns on, check the message in the instrument cluster.















### Overview

Some indicator lights turn on briefly as a function check when you switch the ignition on. These systems are marked with a ✓ in the following tables. If one of these indicator lights does not turn on, there is a malfunction in that system.



Your vehicle has either a monochrome display or a multicolored display, depending on vehicle equipment. Some indicator lights appear white on a monochrome display. The  or  central indicator light turns on at the same time to indicate the priority of these indicator lights.

#### Red indicator lights















	Central indicator light ⇒ <i>page 19</i> ,
	Audi pre sense* ⇒ <i>page 112</i>
<b>BRAKE</b>	<b>USA models:</b> brake system ✓ ⇒ <i>page 22</i>













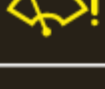







	<b>Canada models:</b> brake system ✓ ⇒ <i>page 22</i>
<b>PARK</b>	<b>USA models:</b> electromechanical parking brake ⇒ <i>page 23</i>
	<b>Canada models:</b> electromechanical parking brake ⇒ <i>page 23</i>
	Cooling system ⇒ <i>page 23</i>
	Engine oil pressure ⇒ <i>page 24</i>
	Engine oil level (MIN)* ⇒ <i>page 24</i>
	Alternator ⇒ <i>page 24</i>
	Safety belt ⇒ <i>page 24</i>
	Electromechanical steering ✓ ⇒ <i>page 144</i>
	Steering lock ⇒ <i>page 24</i>
	Engine start system ⇒ <i>page 25</i>
	Transmission ⇒ <i>page 89</i>
	Hood ⇒ <i>page 25</i>
	Adaptive cruise control* ✓ ⇒ <i>page 104</i>
	Traffic jam assist* ⇒ <i>page 109</i>
	Air suspension* ⇒ <i>page 25</i>



#### Yellow indicator lights

	Central indicator light ⇒ <i>page 19</i>
	Electronic Stabilization Control (ESC) ⇒ <i>page 26</i>











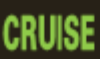

## Cockpit overview









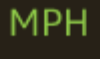
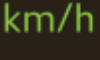









	Electronic Stabilization Control (ESC) ✓ ⇒ page 26
<b>ESC OFF</b>	Electronic Stabilization Control (ESC) ⇒ page 141
	Brake system ⇒ page 26
<b>ABS</b>	<b>USA models:</b> anti-lock braking system (ABS) ✓ ⇒ page 26
	<b>Canada models:</b> anti-lock braking system (ABS) ✓ ⇒ page 26
	Safety systems ✓ ⇒ page 26
<b>BRAKE WEAR</b>	<b>USA models:</b> brake pads ⇒ page 26
	<b>Canada models:</b> brake pads ⇒ page 26
	Electromechanical parking brake ⇒ page 23
	Tire pressure ⇒ page 342
<b>TPMS</b>	Tire pressure ⇒ page 342
	Engine control ⇒ page 26
	Malfunction Indicator Lamp (MIL) ✓ ⇒ page 313
	Engine speed limitation ⇒ page 26
	Engine oil level (MIN)* ⇒ page 24
	Engine oil level (MAX) ⇒ page 317
	Engine oil sensor ⇒ page 27
	Engine warm-up request ⇒ page 27

	Battery charge ⇒ page 24
	Tank system ⇒ page 27
	Washer fluid level ⇒ page 27
	Windshield wipers ⇒ page 27
	Remote control key ⇒ page 76
	Driver's door ⇒ page 27
	Battery in remote control key ⇒ page 32
	Bulb failure indicator ⇒ page 28
	Headlight range control system ⇒ page 28
	Adaptive light* ⇒ page 28
	Light/rain sensor ⇒ page 28
	Active lane assist* ⇒ page 118
	Audi side assist* ⇒ page 125
	Audi pre sense* ⇒ page 116
<b>P</b> 	Parking aid* ⇒ page 138
	Transmission ⇒ page 89
	Steering lock ⇒ page 24
	Engine start system ⇒ page 25
	Electromechanical steering ⇒ page 144
	Air suspension* ⇒ page 25
	Air suspension* ⇒ page 25

	Suspension control* ⇒ page 28
	All wheel drive/sport differential* ⇒ page 28
	Emergency call function* ⇒ page 202

**Other indicator lights**

	Turn signals ⇒ page 29
	Trailer turn signals* ⇒ page 29
	<b>USA models:</b> cruise control system* ⇒ page 95
	<b>Canada models:</b> cruise control system* ⇒ page 95
	Adaptive cruise control* ⇒ page 104
	Adaptive cruise control* ⇒ page 104
	Adaptive cruise control* ⇒ page 104
	Adaptive cruise control* ⇒ page 104
	Adaptive cruise control* ⇒ page 106, ⇒ page 101
	Adaptive cruise control* ⇒ page 101
	Traffic jam assist* ⇒ page 109
	Active lane assist* ⇒ page 118
	Predictive efficiency assist* ⇒ page 100
	<b>USA models:</b> Predictive efficiency assist* ⇒ page 100
	<b>Canada models:</b> Predictive efficiency assist* ⇒ page 100

	Predictive efficiency assist* ⇒ page 100
	Predictive efficiency assist* ⇒ page 100
	Predictive efficiency assist* ⇒ page 100
	Hill descent assist ⇒ page 142
	Start/Stop system* ⇒ page 78
	Start/Stop system* ⇒ page 78
	Remote control key ⇒ page 78
	Transmission ⇒ page 89
	Dynamic steering* ⇒ page 144
	Air suspension* ⇒ page 129
	Adaptive cruise control* ⇒ page 106, Traffic jam assist* ⇒ page 110
	Traffic jam assist* ⇒ page 110
	Audi pre sense* ⇒ page 116
	<b>USA models:</b> electromechanical parking brake ⇒ page 23
	<b>Canada models:</b> electromechanical parking brake ⇒ page 23
	Hill descent assist ⇒ page 142
	Child safety lock ⇒ page 40
	<b>USA models:</b> speed warning system* ⇒ page 95

	<b>Canada models:</b> speed warning system* ⇒ page 95
	Active lane assist* ⇒ page 118
	Audi side assist* ⇒ page 125
	Camera-based traffic sign recognition* ⇒ page 98
	High beam assistant* ⇒ page 46
	High beams ⇒ page 46 High beam assistant* ⇒ page 46

### **BRAKE** / Brake system

If this indicator light turns on, there is a malfunction in the brake system.

**BRAKE** (USA models) /  (Canada models)





**Brakes: stop vehicle and check brake fluid level**

Stop the vehicle and check the brake fluid level. See an authorized Audi dealer or authorized Audi Service Facility for assistance if necessary.

**BRAKE** (USA models) /  (Canada models)

**Brakes: malfunction! Stop vehicle safely**

If the indicator light turns on and this message appears, there is a malfunction in the brake booster.

If the ABS indicator light **ABS** (USA models) /  (Canada models), the ESC indicator light , and the brake system indicator light **BRAKE** (USA models) /  (Canada models) all turn on and this message appears, then the ABS, ESC and braking distribution are malfunctioning ⇒ .

Do not continue driving. See an authorized Audi dealer or authorized Audi Service Facility for assistance ⇒ .

**BRAKE** (USA models) /  (Canada models) **Parking brake: malfunction! Safely stop vehicle. See owner's manual**

- If the indicator light and the message appear **when the vehicle is stationary or after switching the ignition on**, check if you can release the parking brake. If you cannot release the parking brake, see an authorized Audi dealer or authorized Audi Service Facility. If you can release the parking brake and the message still appears, see an authorized Audi dealer or authorized Audi Service Facility immediately to have the malfunction corrected.
- If the indicator light and message appear **while driving**, the hill start assist or emergency braking function may be malfunctioning. It may not be possible to set the parking brake or release it once it has been set. Do not park your vehicle on hills. See an authorized Audi dealer or authorized Audi Service Facility for assistance.

**Brake booster: limited functionality. You can continue driving. Please contact Service**

There is a malfunction in the brake booster. The brake booster is available, but its effectiveness is reduced. Braking behavior may be different from how it normally functions and the brake pedal may vibrate.

Drive to an authorized Audi dealer or authorized Audi Service Facility immediately to have the malfunction corrected.

### **WARNING**

- Read and follow the warnings in ⇒ page 314, *Working in the engine compartment* before opening the hood and checking the brake fluid level.
- If the brake system indicator light does not turn off or it turns on while driving, the brake fluid level in the reservoir is too low, and this increases the risk of an accident. Stop the vehicle and do not continue driving. See an authorized Audi dealer or authorized Audi Service Facility for assistance.
- If the brake system indicator light turns on together with the ABS and ESC indicator lights, the ABS/ESC regulating function may be malfunctioning. Functions that stabilize the vehicle are no longer available. This could cause the vehicle to swerve, which

increases the risk that the vehicle will slide. Do not continue driving. See an authorized Audi dealer or authorized Audi Service Facility for assistance.

## **PARK/Ⓟ/Ⓟ Electromechanical parking brake**

If the **PARK** (USA models) / **Ⓟ** (Canada models) indicator light turns on, the parking brake was set.

If the **PARK** (USA models) / **Ⓟ** (Canada models) indicator light blinks, the braking force is not building up enough or not building up at all. Select the "P" selector lever position to help secure the vehicle. Make sure the indicator light is off before you start driving.

### **Ⓟ Parking brake: malfunction! Please contact Service**

There is a malfunction in the parking brake. Drive to an authorized Audi dealer or authorized Audi Service Facility immediately to have the malfunction corrected.

### **Ⓟ (USA models) / Ⓟ (Canada models) Parking brake: warning! Vehicle parked too steep**

There is not enough braking force to hold the vehicle in place. The brakes have overheated. The vehicle could roll away even on a small incline.

### **Ⓟ (USA models) / Ⓟ (Canada models) Parking brake: applied**

If this message appears, press the brake pedal first and then release the parking brake if necessary.

### **Ⓟ (USA models) / Ⓟ (Canada models) Parking brake: emergency braking**

The emergency braking function was triggered.

#### **Please release parking brake**

Release the parking brake if this message appears.

#### **Please press the brake pedal to release the parking brake**

To release the parking brake, press the brake pedal and press the **Ⓟ** button at the same time, or start driving with hill start assist ⇒ *page 82, Starting to drive*.

### **i Tips**

For additional information on the parking brake, see ⇒ *page 80*.

## **🔧 Cooling system**

### **🔧 Turn off engine and check coolant level. See owner's manual**

The coolant level is too low.

Do not continue driving and switch the engine off. Check the coolant level ⇒ *page 319*.

- If the coolant level is too low, add coolant ⇒ *page 320*. Only continue driving once the indicator light turns off.

### **🔧 Coolant temperature: too high. Let engine run with vehicle stationary**

Let the engine run at idle for a few minutes to cool off, until the indicator light turns off.

- If the indicator light does not turn off, do not continue driving the vehicle. See an authorized Audi dealer or authorized Audi Service Facility for assistance.

### **⚠️ WARNING**

- Never open the hood if you can see or hear steam or coolant escaping from the engine compartment. This increases the risk of burns. Wait until you no longer see or hear steam or coolant escaping.
- The engine compartment in any vehicle can be a dangerous area. Stop the engine and allow it to cool before working in the engine compartment. Always follow the information found in ⇒ *page 314, Working in the engine compartment*.

### **! Note**

Do not continue driving if the **🔧** indicator light turns on as this increases the risk of engine damage.



### Safety belt

The  indicator light stays on until the driver's and front passenger's safety belts are fastened. Above a certain speed, there will also be a warning tone.

### Tips

For additional information on safety belts, see  $\Rightarrow$  page 261.

### Generator/vehicle battery

If the  or  indicator light turns on, there is a malfunction in the generator or the vehicle electrical system.

#### **Electrical system: malfunction! Safely stop vehicle**

Do not continue driving and switch the engine off. See an authorized Audi dealer or authorized Audi Service Facility for assistance.

#### **Electrical system: malfunction! Restart not possible. Please contact Service**

The vehicle battery was disconnected from the vehicle electrical system and will no longer charge. Drive to an authorized Audi dealer or authorized Audi Service Facility immediately.

Do not stop the engine, or you will not be able to start it again. If you can no longer start the engine, see an authorized Audi dealer or authorized Audi Service Facility for assistance.

#### **Electrical system: malfunction! Please contact Service**

Drive to an authorized Audi dealer or authorized Audi Service Facility immediately. Because the vehicle battery is discharging, turn off all unnecessary electrical equipment such as the radio. See an authorized Audi dealer or authorized Audi Service Facility if the battery charge level is too low.

#### **Electrical system: low battery charge. Battery will be charged while driving**

The starting ability may be impaired.

If this message turns off after a little while, the vehicle battery charged enough while driving.

If the message does not turn off and stay off when driving, have an authorized Audi dealer or authorized Audi Service Facility repair the malfunction.

### Engine oil pressure

#### **Turn off engine. Oil pressure too low**

Stop the engine and do not continue driving. Check the engine oil level  $\Rightarrow$  page 317.

- If the engine oil level is too low, add engine oil  $\Rightarrow$  page 317. Only continue driving once the indicator light turns off.
- If the engine oil level is correct and the indicator light still turns on, turn the engine off and do not continue driving. See an authorized Audi dealer or authorized Audi Service Facility for assistance.

### Tips

The oil pressure warning is not an oil level indicator. Always check the oil level regularly.

### Engine oil level (MIN)

Applies to: vehicles with oil level warning

#### **Please add oil immediately.**

Add engine oil immediately  $\Rightarrow$  page 317.

#### **Please add max. x qt (l) oil. You can continue driving**

Add the maximum amount of oil indicated in the display as soon as possible  $\Rightarrow$  page 317.

### Steering lock

#### **Steering: malfunction! Please stop vehicle**

There is a malfunction in the electronic steering lock. You cannot turn the ignition on.

Do **not** tow your vehicle because it cannot be steered. See an authorized Audi dealer or authorized Audi Service Facility for assistance. 

### **Steering lock: malfunction! Please contact Service**

There is a malfunction in the electronic steering lock.

Drive to an authorized Audi dealer or authorized Audi Service Facility immediately to have the malfunction corrected.

#### **WARNING**

Do not tow your vehicle when there is a malfunction in the electronic steering lock - this increases the risk of an accident.

### **Engine start system**

#### **Engine start system: malfunction! Please contact Service**

Do **not** switch the ignition off because you may not be able to switch it on again.

Drive to an authorized Audi dealer or authorized Audi Service Facility immediately to have the malfunction corrected.

#### **Engine start system: malfunction! Please contact Service**

There is a malfunction in the engine starting system.

Drive to an authorized Audi dealer or authorized Audi Service Facility immediately to have the malfunction corrected.

### **Hood**

#### **Warning! Hood is not locked. Stop vehicle and check the lock**

If the indicator light turns on and the message appears, the hood locking mechanism is not engaged correctly.

Stop immediately and close the hood  
⇒ *page 315*.

### **Air suspension**

Applies to: vehicles with air suspension

#### **Air suspension: malfunction. Safely stop vehicle. Steering and ground clearance limited**

Due to a system malfunction, your vehicle's ground clearance is very low at the front or rear axle\* (in vehicles with all-wheel steering). Because of this, the wheels no longer have enough clearance to steer correctly.

See an authorized Audi dealer or authorized Audi Service Facility for assistance.

#### **Air suspension: malfunction! You can continue driving slowly. Speed limited to max. 35 mph (60 km/h)**

There is a malfunction that can result in restricted driving stability. The speed is limited to a maximum of 35 mph (60 km/h).

Drive to an authorized Audi dealer or authorized Audi Service Facility immediately to have the malfunction corrected.

#### **Air suspension: malfunction! You may continue driving slowly at max. 35 mph (60 km/h)**

There is a malfunction that can result in restricted driving stability.

Drive to an authorized Audi dealer or authorized Audi Service Facility immediately at a maximum speed of 35 mph (60 km/h) to have the malfunction corrected.

#### **Air suspension: service mode! Vehicle can be moved but handling may be impaired**

Carefully drive to an authorized Audi dealer or authorized Audi Service Facility immediately to have the service mode deactivated.

#### **Air suspension: malfunction! Please contact Service**

There is a system malfunction that can result in restricted driving stability or reduced ground clearance.

Drive to an authorized Audi dealer or authorized Audi Service Facility immediately to have the malfunction corrected.

#### **Air suspension: vehicle too low. Limited ground clearance**

The ground clearance is very low due to a system malfunction. Wait until the air suspension system has restored normal ground clearance. ▶

Otherwise, conditions such as an uneven road surface can lead to vehicle damage.

### **Suspension: malfunction! You may continue driving**

There is a suspension control malfunction.

Drive to an authorized Audi dealer or authorized Audi Service Facility immediately to have the malfunction corrected.



### **Electronic Stabilization Control (ESC)**

If the  indicator light blinks while driving, the ESC or ASR (Anti-Slip Regulation) is actively regulating.

If the  indicator light turns on, the system has switched the ESC off. In this case, you can switch the ignition off and then on to switch the ESC on again. The indicator light turns off when the system is functioning fully.

If the  indicator light turns on, ESC was switched off using the  button ⇒ *page 140*.

### **Stabilization control (ESC/ABS): malfunction! See owner's manual**

If the  indicator light and the **ABS** (USA models)/ (Canada models) ABS indicator light turn on and the message appears, there is a malfunction in the ABS or the electronic differential lock. This also causes the ESC to malfunction. The brakes still function with their normal power, but ABS is not active.

Drive to an authorized Audi dealer or authorized Audi Service Facility immediately to have the malfunction corrected.

### **Tips**

For additional information on ESC and ABS, see ⇒ *page 140*.

### **Safety systems**

The  indicator light monitors the safety systems.

If the  indicator light turns on or blinks, there is a malfunction in a safety system.

Drive to an authorized Audi dealer or authorized Audi Service Facility immediately to have the malfunction corrected.

### **WARNING**

Have the safety systems inspected immediately. Otherwise, there is a risk that the systems may not activate during a collision, which increases the risk of serious injury or death.

### **Brake system**

#### **Brakes overheating. Please shift to D**

There was a heavy load on the brakes. Place the selector lever in the "D/S" position in order to use the engine braking effect and reduce the load on the brakes.

### **Brake pads**

 (USA models)/ (Canada models) **Brake pads: wear limit reached. You can continue driving. Please contact Service**

The brake pads are worn.

Drive to an authorized Audi dealer or authorized Audi Service Facility as soon as possible to have the malfunction corrected.

### **Engine control**

#### **Drive system: malfunction! Please contact Service**

There is an engine control malfunction.

Drive slowly to an authorized Audi dealer or authorized Audi Service Facility to have the engine checked.

### **Engine speed limitation**

#### **Maximum engine speed: XXXX rpm**

The engine speed is automatically limited to the speed displayed in the instrument cluster. This protects the engine from overheating.

The engine speed limitation deactivates once the engine is no longer in the critical temperature

range and you have released the accelerator pedal once.

If the engine speed limitation was activated by an engine control malfunction, the  indicator light also turns on. Make sure the engine speed does not go above the speed displayed, for example when downshifting. Drive to an authorized Audi dealer or authorized Audi Service Facility immediately to have the malfunction corrected.

### Engine oil sensor

#### Oil level system: malfunction! Please contact Service

The sensor to check the engine oil level has failed. Drive to an authorized Audi dealer or authorized Audi Service Facility immediately to have the malfunction corrected.

#### Oil level sensor: oil change necessary. Please contact Service

Fuel has entered the engine oil as a result of frequent short drives. Avoid high engine speeds, full acceleration and heavy engine loads. Drive to an authorized Audi dealer or authorized Audi Service Facility immediately to have the oil changed.

#### Oil pressure sensor: malfunction! Please contact Service

There is a malfunction in the oil pressure sensor. Drive to an authorized Audi dealer or authorized Audi Service Facility immediately to have the malfunction corrected.

### Engine warm-up request

#### Please drive to warm up engine

Fuel has entered the engine oil, either from low outside temperatures or frequent short drives. Drive until the engine is warm so that the fuel in the engine oil will evaporate. Avoid high engine speeds, full accelerating and heavy engine loads when doing this.

### Tank system

#### Please refuel

If the indicator light turns on for the first time and the message appears, there are about 2.1 gallons (8 liters) of fuel left in the tank.

#### Please refuel immediately

If the indicator light turns on the message appears, the fuel tank is almost empty. Refuel the vehicle immediately.

#### Tank system: malfunction! Please contact Service

There is a malfunction in the fuel tank system.

Drive to an authorized Audi dealer or authorized Audi Service Facility immediately to have the malfunction corrected.

#### Tips

For more information on fueling, see [⇒ page 311](#).

### Washer fluid level

#### Please add washer fluid

Fill the washer fluid for the windshield washer system and the headlight washer system\* when the ignition is switched off [⇒ page 323](#).

### Windshield wipers

#### Windshield wipers: malfunction! Please contact Service

There is a malfunction with the windshield wipers.

Drive to an authorized Audi dealer or authorized Audi Service Facility immediately to have the malfunction corrected.

### Driver's door

#### Driver's door: malfunction! Shift to P before leaving vehicle. See owner's manual

There is a malfunction in the driver's door. Select the "P" selector lever position to secure the vehicle. 

Drive to an authorized Audi dealer or authorized Audi Service Facility immediately to have the malfunction corrected.

### **Bulb failure indicator**

If the  indicator light turns on, a bulb has failed. The message indicates the location of the bulb. Replace the bulb immediately.

### **Vehicle lights: malfunction! Please contact Service**

There is a malfunction in the headlights or the light switch. Drive to an authorized Audi dealer or authorized Audi Service Facility immediately to have the malfunction corrected.

### **WARNING**

- Light bulbs are under pressure and can explode when bulbs are replaced, which increases the risk of injury.
- With HID headlights (xenon headlights), the high-voltage component must be handled correctly. Otherwise, there is a risk of fatal injury.

### **Dynamic headlight range control**

#### **Headlight range control: malfunction! See owner's manual**

There is a malfunction in the headlight range control system, which may cause glare for other drivers.

Drive to an authorized Audi dealer or authorized Audi Service Facility immediately to have the malfunction corrected.

### **Audi adaptive light**

Applies to: vehicles with Audi adaptive light

#### **Audi adaptive light: malfunction! See owner's manual**

Adaptive light is not working. The headlights still function.

Drive to an authorized Audi dealer or authorized Audi Service Facility immediately to have the malfunction corrected.

### **Light/rain sensor**

#### **Automatic headlights: malfunction! See owner's manual**

#### **Automatic wipers: malfunction! See owner's manual**

The light/rain sensor is malfunctioning.

The low beams remain switched on at all times for safety reasons when the light switch is in the **AUTO** position. However, you can continue to turn the lights on and off using the light switch. You can still control all functions that are independent of the rain sensor through the windshield wiper lever.

Drive to an authorized Audi dealer or authorized Audi Service Facility immediately to have the malfunction corrected.

### **Suspension control**

Applies to: vehicles with suspension control

#### **Suspension: malfunction! You may continue driving**

There is a suspension control malfunction.

Drive to an authorized Audi dealer or authorized Audi Service Facility immediately to have the malfunction corrected.

### **All wheel drive/sport differential**

Applies to: vehicles with all wheel drive/sport differential

#### **All-wheel drive: malfunction! You may continue driving. Please contact Service**

#### **Sport differential: malfunction! Please contact Service**

There is a malfunction.

Drive to an authorized Audi dealer or authorized Audi Service Facility immediately to have the malfunction corrected.

#### **All-wheel drive overheating. Please adapt driving style. See owner's manual**

#### **Sport differential: temperature too high. Please adapt driving style**



The transmission temperature has increased significantly due to the sporty driving manner. Drive in a less sporty manner until the temperature returns to the normal range and the indicator light switches of.



### WARNING

Contact an authorized Audi dealer or authorized Audi Service Facility if the all wheel drive/sport differential is faulty or malfunctioning. The repair must be performed by trained personnel using the correct oil in order to ensure safety.

### Turn signals

If the  or  indicator light blinks, a turn signal is turned on. If both indicator lights are blinking, the emergency flashers are on.

If an indicator light blinks twice as fast as usual, a turn signal bulb has failed. Carefully drive to an authorized Audi dealer or authorized Audi Service Facility immediately to have the malfunction corrected.

### Trailer turn signals

Applies to: vehicles with trailer hitch

The turn signals are activated in trailer mode if the  indicator light blinks.

If a turn signal on the trailer or on the vehicle fails while in trailer mode, the indicator light will **not** blink twice as fast to indicate this.

# Opening and closing

## Central locking

### Description

You can lock and unlock the vehicle centrally. You have the following options:

- Remote control key ⇒ *page 33*
- Sensors in the door handles\* ⇒ *page 33*
- Lock cylinder on the driver's door ⇒ *page 35*,  
or
- Interior central locking switch ⇒ *page 34*

### Turn signals

The turn signals flash twice when you unlock the vehicle and flash once when you lock the vehicle. If they do not flash, then one of the doors, the luggage compartment lid or the hood is not closed completely.

### Automatic locking (Auto Lock)

The Auto Lock function locks all doors and the luggage compartment lid once the speed has exceeded approximately 9 mph (15 km/h).

The vehicle can be unlocked if the opening function in the central locking system switch is used or one of the door handles is pulled.

In the event of a crash with airbag deployment, the doors will also automatically unlock to allow access to the vehicle.

### Selective door unlocking

The doors and luggage compartment lid will lock when they close. You can set in the Infotainment system whether *only* the driver's door or the entire vehicle should be unlocked when unlocking ⇒ *page 35*.

### Unintentionally locking yourself out

Only lock your vehicle when all of the doors and the luggage compartment lid are closed and the remote control key is not in the vehicle. This helps to prevent you from locking yourself out accidentally.

The following conditions prevent you from locking your remote control key in the vehicle:

- If the driver's door is open, the vehicle cannot be locked by pressing the  button on the remote control key or by touching the locking sensor\* on a door.
- If the most recently used convenience key\* is detected in the luggage compartment, the luggage compartment lid automatically unlocks again after closing it.
- If the convenience key\* that was last used is detected inside the vehicle, then the vehicle cannot be locked from the outside.

### WARNING

- If you leave the vehicle, switch the ignition off and take the vehicle key with you. This applies particularly when children remain in the vehicle. Otherwise, children could start the engine or operate electrical equipment (such as power windows), which increases the risk of an accident.
- No one, especially children, should stay in the vehicle when it is locked from the outside, because the windows can no longer be opened from the inside ⇒ *page 36*. Locked doors make it more difficult for emergency workers to get into the vehicle, which puts lives at risk.

### Tips

- Do not leave valuables unattended in the vehicle. A locked vehicle is not a safe!
- The LED in the driver's door rail blinks when you lock the vehicle. If the LED lights up for approximately 30 seconds after locking, there is a malfunction in the central locking system. Have the problem corrected by an authorized Audi dealer or authorized Audi Service Facility.

## Key set

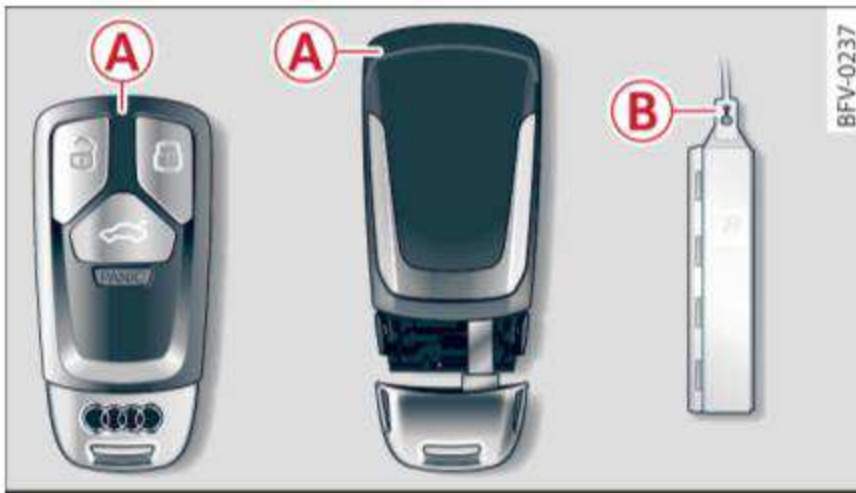

Fig. 17 Your vehicle key set

**(A) Remote control key or convenience key\***

The convenience key\* is a remote control key with special functions ⇒ *page 33* and ⇒ *page 76*.

You can unlock/lock your vehicle with the remote control key. A mechanical key is integrated in the remote control key ⇒ *page 32*.

**(B) Key fob with vehicle code**

Applies to vehicles with Audi connect vehicle control

Open the key tag and scratch to reveal the vehicle code. You can unlock the Audi connect vehicle control services\* for your vehicle with this vehicle code. For additional information, see ⇒ *page 197*.

**Replacing a key**

If a key is lost, see an authorized Audi dealer or authorized Audi Service Facility. Have this key deactivated. It is important to bring all keys with you. If a key is lost, you should report it to your insurance company.

**Number of keys**

You can check the number of keys assigned to your vehicle in the Infotainment system. To do this, select the **MENU** button > **Vehicle** > left control button > **Service & checks** > **Vehicle information**. This way, you can make sure that you have all the keys when purchasing a used vehicle.

**Electronic immobilizer**

The immobilizer prevents unauthorized use of the vehicle.

Under certain circumstances, the vehicle may not be able to start if there is a key from a different vehicle manufacturer on the key chain.

**Data in the master key**

When driving, service and maintenance-relevant data is continuously stored in your remote control key. Your Audi service advisor can read out this data and tell you about the work your vehicle needs. This applies also to vehicles with a convenience key\*.

**Personal convenience settings**

If two people use one vehicle, it is recommended that each person always uses their own remote control key. When the ignition is turned off or when the vehicle is locked, personal convenience settings for the following systems are stored and assigned to the remote master key.

- Climate control system
- Steering wheel heating\*
- Central locking system
- Interior lighting\*
- Exterior lighting
- Rain sensor
- Memory function\*
- Parking aid\*
- Adaptive cruise control\*
- Active lane assist\*
- Side assist\*
- Traffic jam assist\*
- Distance warning\*
- Audi pre sense\*
- Speed warning\*

The stored settings are automatically recalled when you unlock the vehicle, open the doors or turn on the ignition.

**! Note**

Protect the remote control key against high temperatures and direct sunlight.

**i Tips**

- The operation of the remote control key can be temporarily disrupted by interference from transmitters near the vehicle working

in the same frequency range (such as a cell phone or radio equipment). Always check if your vehicle is locked!

- For an explanation on conformity with the FCC regulations in the United States and the Industry Canada regulations, see ⇒ page 374.

### Removing the mechanical key

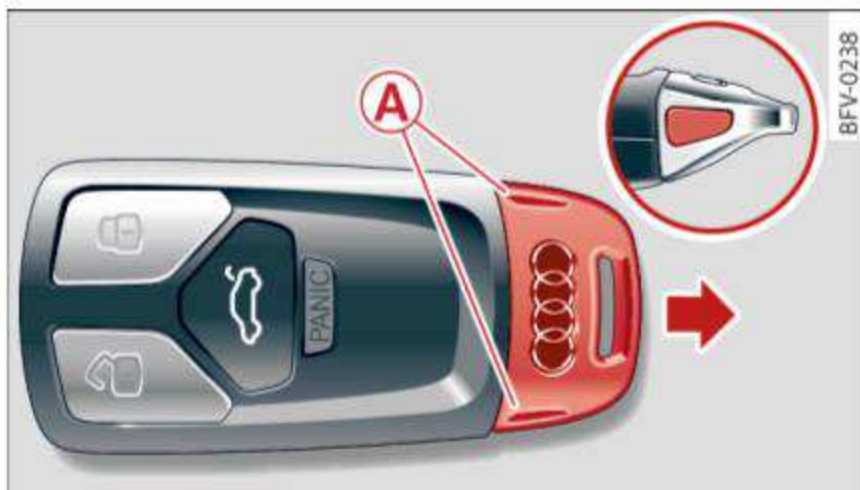

Fig. 18 Remote control master key: removing the mechanical key

- ▶ Press the release buttons **A** ⇒ fig. 18 and remove the mechanical key from the remote control key.

Using the mechanical key, you can:

- Lock/unlock the glove compartment.
- Manually lock/unlock the vehicle ⇒ page 35.
- Mechanically lock the doors ⇒ page 35.

### LED and battery in the remote control key

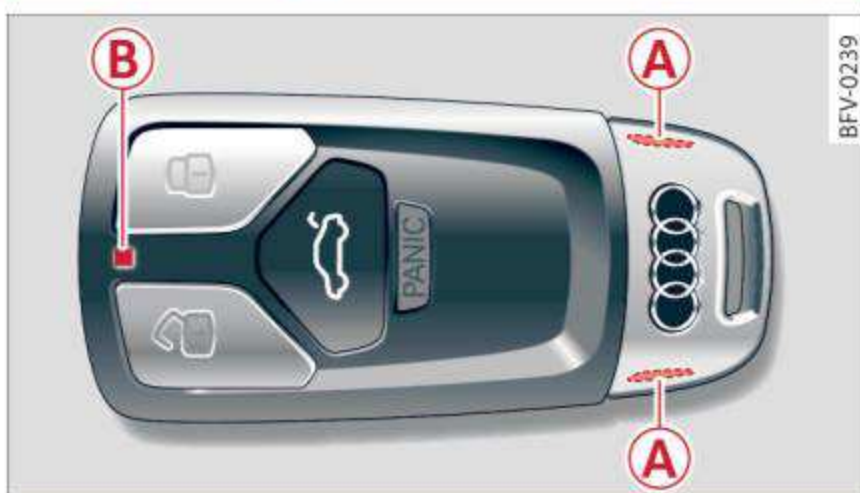

Fig. 19 Remote control key: removing the battery holder

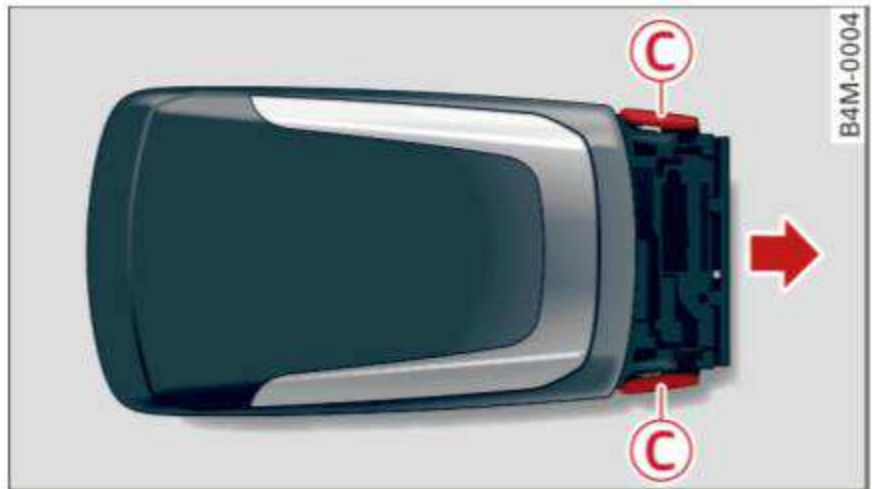



Fig. 20 Remote control key (rear side): removing the battery holder

### LED on the remote control key

The LED **B** informs you of the remote control key function.

- ▶ If you press a button briefly, the LED blinks once.
- ▶ If you press and hold a button (convenience opening/closing), the LED blinks several times.
- ▶ If the LED does not blink, the remote control key battery is dead. The  indicator light turns on and the message **Remote control key: replace key battery** appears in the driver information system. Replace the battery in the remote control key.

### Replacing the remote control key battery

- ▶ Press the release buttons **A** ⇒ fig. 19 and remove the mechanical key.
- ▶ Press the release buttons **C** ⇒ fig. 20 on the battery holder while pulling the battery holder out of the remote control key in the direction of the arrow.
- ▶ Insert the new battery with the “+” facing down.
- ▶ Slide the battery holder carefully into the remote control key.
- ▶ Insert the mechanical key.



### For the sake of the environment

Discharged batteries must be disposed of using methods that will not harm the environment. Do not dispose of them in household trash.

**i Tips**

The replacement battery must meet the same specifications as the original battery in the remote control key.







**Unlocking/locking by remote control**

Fig. 21 Remote control key: button programming

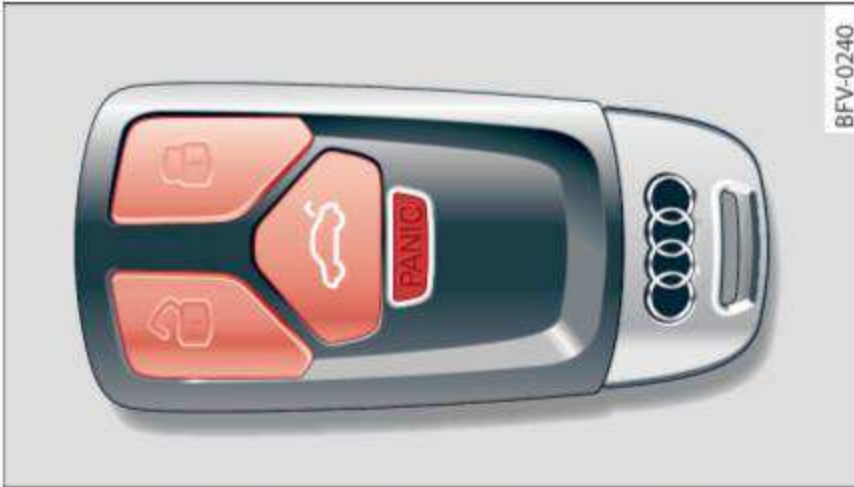
- ▶ To unlock the vehicle, press the  button ⇒ *fig. 21*.
- ▶ To lock the vehicle, press the  button **one time** ⇒ .
- ▶ To unlock the luggage compartment lid, press the  button briefly.
- ▶ To open the luggage compartment lid, press and hold the  button for at least one second.
- ▶ To trigger the alarm, press the red **PANIC** button. The vehicle horn and emergency flashers will activate.
- ▶ To switch off the alarm, press the red **PANIC** button again.

If you unlock the vehicle and do not open any of the doors, the hood, or the luggage compartment lid within 45 seconds, the vehicle automatically locks again. This feature prevents the vehicle from being accidentally left unlocked over a long period of time.

The settings in the Infotainment system determine if the entire vehicle or only the driver's door is unlocked when unlocking the vehicle ⇒ *page 35*.

**! WARNING**

No one, especially children, should stay in the vehicle when it is locked from the outside, because the windows can no longer be opened

from the inside ⇒ *page 36*. Locked doors make it more difficult for emergency workers to get into the vehicle, which puts lives at risk.

**i Tips**

- Only use the remote control key when you are within view of the vehicle.
- The vehicle can only be locked when the selector lever is in the "P" position.
- Do not use the remote control when you are inside the vehicle. Otherwise, you could unintentionally lock the vehicle. If you then try to open a door, the anti-theft alarm will trigger. If this happens, press the unlock button .
- Only use the panic function in an emergency.

**Unlocking/locking with the convenience key**

Applies to: vehicles with convenience key

*The doors and luggage compartment lid can be unlocked/locked without using the remote control key.*



Fig. 22 Door handle: locking the vehicle

**Unlocking the vehicle**

- ▶ Grip the door handle. The door unlocks automatically.
- ▶ Pull on the door handle to open the door.

**Locking the vehicle**

- ▶ Select the "P" position. The vehicle cannot be locked if "P" is not selected.

## Opening and closing

- ▶ To lock the vehicle, close the door and touch the sensor in the door handle **once** ⇒ *fig. 22*. Do not hold the door handle while doing this.

You can unlock/lock the vehicle at every door. The remote control key cannot be more than approximately 4 feet (1.5 m) away from the door handle. It makes no difference whether the master key is in your jacket pocket or in your briefcase, for example.

If you hold the door handle while locking, this can impair the locking function.

The door cannot be opened for a brief period directly after locking it. This way you have the opportunity to check if the doors locked correctly.

The settings in the Infotainment system determine if the entire vehicle or only one of the doors is unlocked when unlocking the vehicle ⇒ *page 35*.

### **WARNING**

Read and following all WARNINGS ⇒  *in Description on page 30*.

### **Tips**

If your vehicle is left standing for a long period of time, note the following:

- The energy management system gradually turns off unnecessary convenience functions to prevent the vehicle battery from draining and to maintain the vehicle's ability to start for as long as possible. You may not be able to unlock your vehicle using the convenience key.



### **Tips**

Unlocking with the convenience key (keyless access) can be deactivated in the Infotainment system ⇒ *page 35*.

## Central locking switch





**Fig. 23** Driver's door: central locking switch

- ▶ To lock the vehicle, press the  button ⇒ .
- ▶ To unlock the vehicle, press the .

When locking the vehicle with the central locking switch, the following applies:

- Opening the doors and the luggage compartment lid from the outside is not possible for security reasons, such as when stopped at a light.
- The LED in the central locking switch turns on when all doors are closed and locked.
- You can open the doors individually from the inside by pulling the door handle.
- In the event of a crash with airbag deployment, the doors unlock automatically to allow access to the vehicle.

### **WARNING**

- The central locking switch also works when the ignition is switched off and automatically locks the entire vehicle when the  button is pressed.
- The central locking switch is inoperative when the vehicle is locked from the outside.
- Locked doors make it more difficult for emergency workers to get into the vehicle, which puts lives at risk. Do not leave anyone behind in the vehicle, especially children.
- Read and following all WARNINGS ⇒  *in Description on page 30*.

### **Tips**

Your vehicle locks automatically when it reaches a speed of 9 mph (15 km/h) (Auto Lock) ⇒ *page 30*. You can unlock the vehicle

again using the  button in the central locking switch.

### Setting the central locking system

You can set which functions are controlled by the central locking system.

- ▶ Select in the Infotainment system: **MENU** button > **Vehicle** > left control button > **Vehicle settings** > **Central locking**.

**Door unlocking** - you can decide if **All** doors or only the **Driver's door** should unlock. The luggage compartment lid also unlocks when **All** is selected. If you select **Driver's door\*** in a vehicle with a **convenience key**, only the driver's door will unlock when you grasp the driver's door handle. If you grasp another door handle, the entire vehicle will be unlocked.

If you select **Driver's door**, all the doors and luggage compartment lid will unlock if you press the  button on the remote control key twice.

Applies to: vehicles with convenience key: **Open with convenience key** - you can deactivate the function for unlocking via the sensor. The function for locking via the sensor will still be enabled ⇒ *page 33*.

**Disable rear lid handle** - if you select **On**, the luggage compartment lid handle is locked. In this case, the luggage compartment lid can be opened with the  button on the remote control key or with the unlock button in the driver's door. In vehicles with a convenience key\*, you can still open the luggage compartment lid using the handle if an authorized remote control key is near the proximity sensor\*.

**Fold mirrors\*** - if you select **On**, the exterior rear-view mirrors fold in automatically when you press the  button on the remote control key or touch the sensor\* in the handle.

**Tone when locking<sup>1)</sup>** - if you select **On**, a tone will sound when you lock the vehicle.

### Mechanically locking/unlocking the doors

If the central locking fails, you must unlock/lock the doors separately.

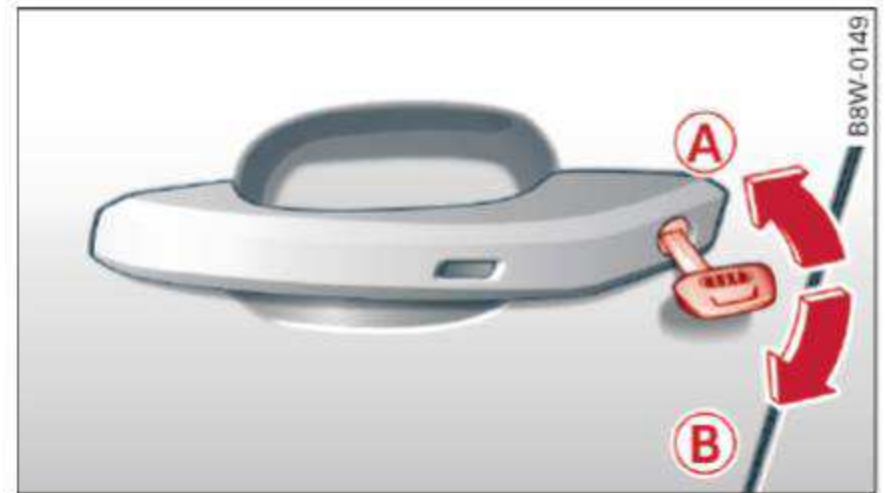



Fig. 24 Driver's door: door lock cylinder



Fig. 25 Door: mechanically locking

### Unlocking/locking the driver's door with the mechanical key

- ▶ Remove the mechanical key ⇒ *page 32*.
- ▶ To unlock the driver's door, turn the key to the unlock position **A** ⇒ *fig. 24*.
- ▶ To lock the driver's door, select the "P" position and turn the key **once** to the closing position **B** ⇒ .

### Locking the front passenger's door/rear doors with the mechanical key

The mechanical lock is located on the edge of the front passenger's door and the rear doors. It is only visible when the door is open.

- ▶ Remove the mechanical key ⇒ *page 32*.
- ▶ Remove the cap from the opening ⇒ *fig. 25*.
- ▶ Insert the key in the inside slot and turn it all the way to the right (right door) or left (left door).

<sup>1)</sup> This function is not available in all countries.

### **WARNING**

Read and following all WARNINGS ⇨  in Description on page 30.

### **Anti-theft alarm system**

Applies to: vehicles with anti-theft alarm system

If the anti-theft alarm system detects a vehicle break-in, audio and visual warning signals are triggered. The anti-theft alarm system is switched on or off when locking/unlocking your vehicle. If the alarm is triggered, it will shut off automatically after a certain amount of time.

#### **Switching the alarm off manually**

- ▶ To switch the alarm off, press the  button on the remote control key or switch the ignition on.

Depending on the vehicle equipment, the anti-theft alarm system may have the following features:

#### **Break-in security feature**

The alarm will sound if there is a break-in at the doors, hood, and/or luggage compartment lid.

#### **Interior/towing protection monitoring button\***

The alarm will be triggered if there are movements detected in the vehicle interior or if there is a change in the vehicle angle.

If you leave persons/animals in the vehicle or have the vehicle transported, switch off the interior/towing protection monitoring alarm to prevent the alarm from being triggered:

- ▶ Press the  button on the remote control key a second time **within 2 seconds**. Or
- ▶ Applies to vehicles with convenience key: touch the sensor on the door handle a second time **within 2 seconds**. Or
- ▶ Turn the mechanical key in the door lock to the close position a second time **within 2 seconds**.
- ▶ If you lock the vehicle now, then the interior/towing protection monitor will stay off until the next time the vehicle is unlocked.

### **Tips**

The interior/towing protection monitoring\* only functions correctly when the windows and the roof\* are closed.



## Luggage compartment lid

### **Opening/closing the luggage compartment lid**



Fig. 26 Driver's door: opening the luggage compartment lid

#### **Opening the luggage compartment lid**

- ▶ Press and hold the  button on the remote control key for at least one second. The luggage compartment lid unlocks and opens slightly. Or
- ▶ Press the handle in the luggage compartment lid. Or
- ▶ Move the selector lever to the "P" position and pull the  button\* in the driver's door.

#### **Closing the luggage compartment lid**

- ▶ Use the inside grip to pull the luggage compartment lid down and allow it to close using a gentle push ⇨ .

### **WARNING**

- After closing the luggage compartment lid, make sure that it is latched. Otherwise, the luggage compartment lid could open suddenly when driving, which increases the risk of an accident.
- Never drive with the luggage compartment lid ajar or open, because poisonous gases can enter the vehicle interior and create the risk of asphyxiation.

- Never leave your vehicle unattended when the luggage compartment lid is open. A child could climb into the vehicle through the luggage compartment. If the luggage compartment lid was then closed, the child would be trapped in the vehicle and unable to escape. To reduce the risk of injury, do not allow children to play in or around the vehicle. Always keep the luggage compartment lid and the doors closed when the vehicle is not in use.
- Always make sure no one is in the luggage compartment lid's range of motion when it is closing, especially near the hinges. Fingers or hands could be pinched.

### **i** Tips

- When the vehicle is locked, the luggage compartment lid can be unlocked separately by pressing the  button on the remote control key. The luggage compartment lid locks automatically when it is closed again.
- The settings in the Infotainment system determine if the luggage compartment lid can be opened using the handle ⇒ *page 35*.

### Automatic luggage compartment lid

Applies to: vehicles with automatic luggage compartment lid

*The luggage compartment lid can be opened and closed electrically.*





**Fig. 27** Driver's door: opening the luggage compartment lid













**Fig. 28** Luggage compartment lid: (A) closing button, (B) lock button (vehicles with convenience key\*)

### Opening the luggage compartment lid

- ▶ Press and hold the  button on the remote control key for at least one second. Or
- ▶ Press the handle in the luggage compartment lid. Or
- ▶ Move the selector lever to the "P" position and pull the  button\* in the driver's door.





### Closing the luggage compartment lid



- ▶ When the ignition is switched on, pull the  switch in the driver's door until the luggage compartment lid is closed ⇒ . Or
- ▶ Press the  button in the luggage compartment lid ⇒ *fig. 28*. The luggage compartment lid will automatically lower and close ⇒ . Or
- ▶ Applies to: vehicles with convenience key: Press the  button on the remote control key until the luggage compartment lid closes ⇒ . Make sure there is enough distance between you and the luggage compartment lid. There should be a maximum 9 feet (3 m) of distance. Or
- ▶ Applies to: vehicles with convenience key: press the  button in the luggage compartment lid ⇒ *fig. 28*. The remote control key must not be more than approximately 4 feet (1.5 m) away from the luggage compartment and it must not be inside the vehicle. The luggage compartment lid will automatically lower and close. The vehicle locks ⇒ . Or
- ▶ Lightly pull the luggage compartment lid at the inner grip. The luggage compartment lid will automatically lower and close ⇒ . Or
- ▶ Press the handle in the luggage compartment lid. The luggage compartment lid will automatically lower and close ⇒ .

### Storing the luggage compartment lid opening position

- ▶ Bring the luggage compartment lid into the desired open position. The position must be at a certain height or higher to store.
- ▶ Press and hold the  button in the luggage compartment lid for at least four seconds to store the new open position. A visual and audio signal will follow.
- ▶ To set a higher open position, wait at least five seconds and then carefully press the luggage compartment lid upward.
- ▶ Press and hold the  button again for at least four seconds to store the desired opening position.

The opening/closing process will stop immediately if:

- You pull/release the  switch in the driver's door, or
- Applies to: vehicles with convenience key: press/release the  button on the remote control key, or
- Applies to: vehicles with convenience key: press the  button or the  button in the luggage compartment lid, or
- You push the handle in the luggage compartment lid, or
- When something blocks the luggage compartment lid or makes it difficult for the lid to move.

If you press the handle or one of the  or  buttons (vehicles with convenience key\*) now, the luggage compartment lid will either open or close, depending on its angle.

### WARNING



- After closing the luggage compartment lid, make sure that it is latched. Otherwise, the luggage compartment lid could open suddenly when driving, which increases the risk of an accident.
- Pay careful attention when closing the luggage compartment lid. Otherwise, you could cause serious injury to yourself or others despite the pinch protection.

- To reduce the risk of pinching injuries, always make sure that no one is in the operating area of the luggage compartment lid, including the hinge areas and the upper and lower edge of the luggage compartment lid.
- Never drive with the luggage compartment lid ajar or open, because poisonous gases can enter the vehicle interior and create the risk of asphyxiation.
- If there is a luggage rack (such as a bicycle rack) on the luggage compartment lid, the luggage compartment lid may not open completely under certain circumstances or it could close by itself if open due to the extra weight. Therefore, the open luggage compartment lid must be given additional support or the cargo must first be removed from the luggage rack.

### Note

The luggage compartment lid can bump into objects such as the garage ceiling when opening and become damaged.

### Tips

- The settings in the Infotainment system determine if the luggage compartment lid can be opened using the handle  *page 35*.
- There are audible signals when closing the luggage compartment lid with the remote control key (vehicles with convenience key\*) or with the  button in the driver's door.
- When the vehicle is locked, the luggage compartment lid can be unlocked separately by pressing the  button on the remote control key. The luggage compartment lid locks automatically when it is closed again.
- Applies to: vehicles with convenience key: The luggage compartment lid can be closed with the convenience from a distance up to approximately 9 ft (3 m).
- The luggage compartment lid can be operated manually if the vehicle battery is low. It is necessary to use more force when doing this. Move the lid slowly to reduce the amount of force needed.

- When the trailer socket is being used (for example, for a bicycle rack), the luggage compartment lid can be opened and closed using the handle or the foot motion activation (vehicles with convenience key\*).

### Opening/closing the luggage compartment lid with foot motion activation (kicking movement)

Applies to: vehicles with convenience key and sensor-controlled luggage compartment lid



Fig. 29 Rear of the vehicle: foot movement

You can open and close the luggage compartment lid with foot motion activation.

Requirements: you must be carrying your convenience key\* with you. You must be standing at the center behind the luggage compartment lid. The ignition must be switched off. Make sure you have firm footing.

- Move your foot back and forth under the bumper one time ⇒ *fig. 29*. Do not touch the bumper. The luggage compartment lid will open/close once the system detects the movement.

The luggage compartment lid will only open/close if you perform the movement as described. This prevents the luggage compartment lid from opening or closing due to similar movements, such as when you walk between the rear of the vehicle and your garage door.

The closing of the luggage compartment lid is indicated by a warning signal and can be canceled by making the described movement again.

The foot movement does not lock the vehicle.

### General information

In some situations, the function may be limited or temporarily unavailable. This may happen if:

- the luggage compartment lid was closed immediately before
- you park close to a hedge and the branches move back and forth under the vehicle for a long period of time
- you clean your vehicle, for example with a pressure washer or in a car wash
- there is heavy rain
- the bumper is very dirty, for example after driving on salt-covered roads
- there is interference to the radio signal from the vehicle key, such as from cell phones or remote controls

### WARNING

- Pay careful attention when closing the luggage compartment lid. Otherwise, you could cause serious injury to yourself or others despite the pinch protection.
- To reduce the risk of pinching injuries, always make sure that no one is in the operating area of the luggage compartment lid, including the hinge areas and the upper and lower edge of the luggage compartment lid.
- Never drive with the luggage compartment lid ajar or open, because poisonous gases can enter the vehicle interior and create the risk of asphyxiation.
- If there is a luggage rack (such as a bicycle rack) on the luggage compartment lid, the luggage compartment lid may not open completely under certain circumstances or it could close by itself if open due to the extra weight. Therefore, the open luggage compartment lid must be given additional support or the cargo must first be removed from the luggage rack.

### Luggage compartment lid emergency release

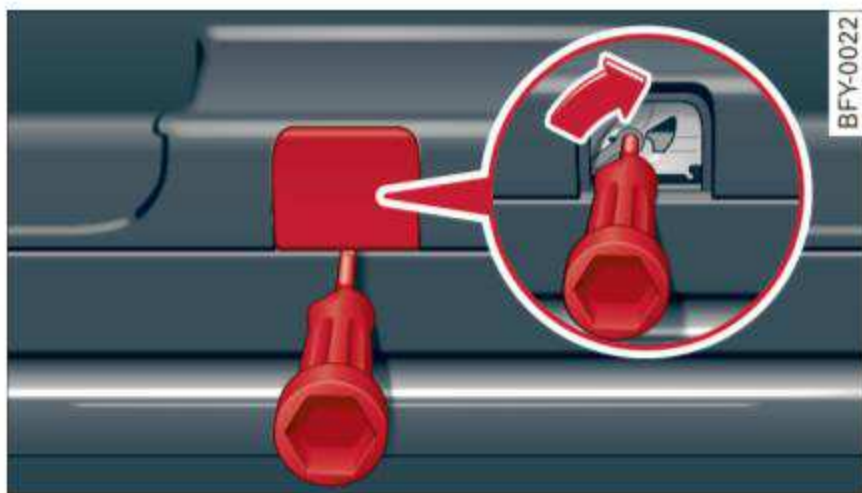

Fig. 30 Inner luggage compartment lid: access to the emergency release

- ▶ Remove the screwdriver from the vehicle tool kit.
- ▶ Use the screwdriver to pry the cover off ⇒ fig. 30.
- ▶ Press the lever in the direction of the arrow to release the luggage compartment lid.

### Child safety lock

The child safety lock prevents the rear doors from being opened from the inside and the rear power windows from being operated.



Fig. 31 Section of driver's door: controls



Fig. 32 Rear door: child safety lock

- ▶ To deactivate/activate the power window switch in the rear doors, press the  button in the driver's door ⇒ fig. 31. The indicator light in the button turns on/blinks.
- ▶ To also deactivate/activate the inner door handle, open the respective rear door and turn the key switch with the mechanical key in the direction of the arrow or opposite the direction of the arrow ⇒ fig. 32.

### Message in the instrument cluster display

#### Childproof catch: malfunction! Please contact Service

There is a malfunction in the child safety lock. Press the  button again.

If the message stays on, drive immediately to an authorized Audi dealer or authorized Audi Service Facility to have the malfunction repaired.

#### WARNING

- If you leave the vehicle, switch the ignition off and take the vehicle key with you. This applies particularly when children remain in the vehicle. Otherwise children could start the engine or operate electrical equipment (such as power windows), which increases the risk of an accident.
- A malfunction in the child safety lock could allow the rear doors to be opened from the inside, which increases the risk of an accident.

### Power windows

#### Controls

The driver can control all power windows.

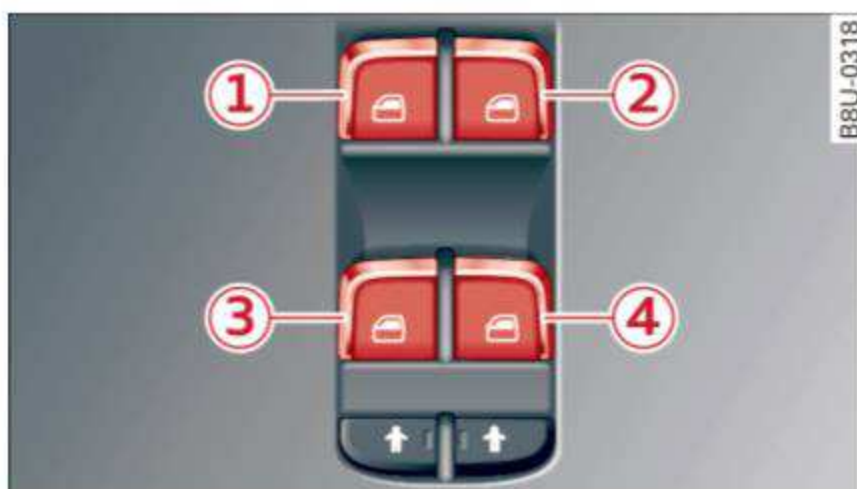

Fig. 33 Driver's door: power window controls

All power window switches are equipped with a two-stage function\*:

### Opening and closing the windows

- ▶ To open or close the window completely, press the switch down or pull the switch up briefly to the second level. The operation will stop if the switch is pressed/pulled again.
- ▶ To select a position in between opened and closed, press/pull the switch to the first level until the desired window position is reached.

### Power window switches

- ① Left front door
- ② Right front door
- ③ Left rear door\*
- ④ Right rear door\*

#### WARNING

- If you leave the vehicle, switch the ignition off and take the vehicle key with you. This applies particularly when children remain in the vehicle. Otherwise children could start the engine or operate electrical equipment (such as power windows), which increases the risk of an accident. The power windows continue to function until the driver's door or front passenger's door has been opened.
- Pay careful attention when closing the windows. Pinching could cause serious injuries.
- When locking the vehicle from outside, the vehicle must be unoccupied since the windows can no longer be opened in an emergency.

#### Tips

You can still open and close the windows for approximately 10 minutes after turning the ignition off. The power windows do not switch off until the driver's door or front passenger's door has been opened.

### Convenience opening/closing



Applies to: vehicles with convenience key

*All of the windows and the roof\* can be opened/closed at the same time.*

#### Convenience opening feature

- ▶ Press and hold the  button on the remote control key until all of the windows reach the desired position and the roof\* is tilted open.



#### Convenience closing feature

- ▶ Press the  button on the remote control key until the roof\* is closed ⇒ , or
- ▶ Touch the sensor\* on the door handle until all of the windows and the roof\* are closed. Do not place your hand in the door handle when doing this.

#### Setting convenience opening in the Infotainment system

- ▶ Select in the Infotainment system: **MENU** button > **Vehicle** > left control button > **Vehicle settings** > **Central locking** > **Long press to open windows**.

#### WARNING

- Never close the windows or the roof\* carelessly or in an uncontrolled manner, because this increases the risk of injury.
- For security reasons, the windows and the roof\* can only be opened and closed with the remote control key at a maximum distance of approximately 6.5 feet (2 m) away from the vehicle. Always pay attention when using the  button to close the windows and the roof\* so that no one is pinched. The closing process will stop immediately when the  button is released.

#### Tips

Applies to: vehicles with panorama glass roof: the power sunshade also opens/closes when opening/closing the roof.

### Correcting power window malfunctions

You can reactivate the one-touch up/down function if it malfunctions.

- ▶ Pull the power window switch up until the window is completely raised.
- ▶ Release the switch and pull it up again for at least one second.

## Panorama glass roof

### Panorama glass roof, opening/closing the sunshade

Applies to: vehicles with panorama glass roof

The front segment can tilt and slide open.

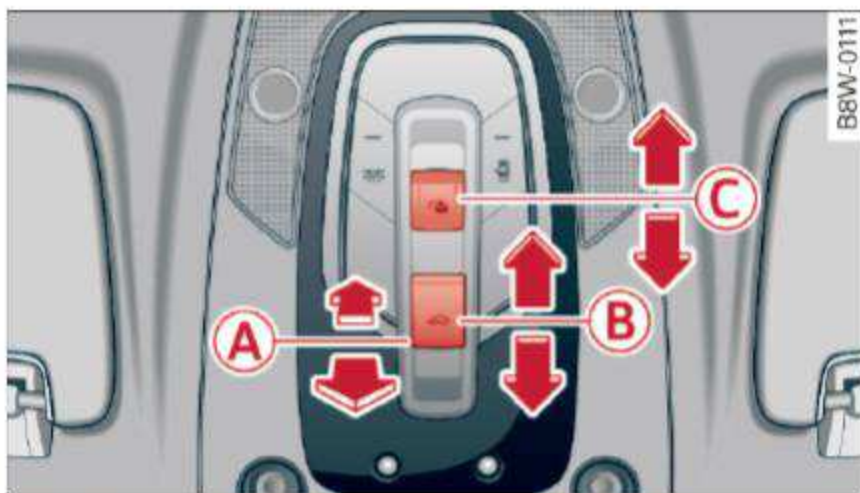

Fig. 34 Section of the front headliner: panorama glass roof button

#### A Tilting and closing the roof

- ▶ To tilt the sunroof completely open, press the ☁ button up briefly to the second level.
- ▶ To close the sunroof completely, pull the ☁ button down briefly to the second level ⇒ ⚠.
- ▶ To set a position between opened and closed, press/pull the ☁ button up to the first level until the roof reaches the desired position.

#### B Opening and closing the roof

- ▶ To move the roof into the reduced wind noise position, push the ☁ button back briefly to the second level.
- ▶ To open the sunroof completely, push the ☁ button back briefly again to the second level.
- ▶ To close the sunroof completely, push the ☁ button forward briefly to the second level ⇒ ⚠.

- ▶ To select a partially open position, push the ☁ button forward/back to the first level until the desired position is reached.

#### C Opening and closing the sunshade

- ▶ To open the sunshade completely, slide the ☁ button back briefly to the second level.
- ▶ To close the sunshade completely, slide the ☁ button forward briefly to the second level.
- ▶ To select a partially open position, slide the ☁ button to the first level until the sunshade reaches the desired position.

#### ⚠ WARNING

To reduce the risk of injury, always pay attention when closing the panorama glass roof. Always switch the ignition off when leaving the vehicle and always take the vehicle with you.

#### ! Note

Always close the panorama glass roof when leaving your vehicle. Rain can cause damage to the interior equipment of your vehicle, particularly the electronic equipment.

#### i Tips

- For information about convenience opening/closing, see ⇒ page 41.
- You can still operate the panorama glass roof for about 10 minutes after the ignition is switched off. The switch is deactivated once the driver's or front passenger's door is opened.
- The panorama glass roof will only open at temperatures down to -4°F (-20°).

### Panorama glass roof emergency operation

Applies to: vehicles with panorama glass roof

If an object is detected when closing, the roof will open again automatically. In this case, you can then close it with the power emergency closing function.

- ▶ Within five seconds after the sunroof opens automatically, pull the applicable button until the roof is closed.

## Garage door opener (HomeLink)

### Description

Applies to: vehicles with garage door opener (HomeLink)



Fig. 35 Garage door opener: examples of usage for different systems

With the garage door opener (HomeLink), you can activate systems such as the garage doors, security systems or house lights from inside your vehicle. Three buttons are integrated in the headliner that can be programmed to up to three remote controls.

To be able to operate systems using the garage door opener, the buttons in the headliner must first be programmed.

### ⚠ WARNING

When operating or programming the garage door opener, make sure that no people or objects are in the area immediately surrounding the equipment. People can be injured or property can be damaged if struck when closing.

### i Tips

- For security reasons, we recommend that you clear the programmed buttons before selling the vehicle.
- For additional information about HomeLink, visit [www.homelink.com](http://www.homelink.com).
- For an explanation on conformity with the FCC regulations in the United States and the Industry Canada regulations, see ⇒ page 374.

### Operating

Applies to: vehicles with garage door opener (HomeLink)

Requirements: the button in the headliner must be programmed ⇒ page 43 and the vehicle must be within range of the system, such as the garage door.

- ▶ Press the button to open the garage door. The LED (A) ⇒ page 43, fig. 36 blinks or turns on.
- ▶ Press the button again to open the garage door.

### i Tips

When opening or closing the garage door, do not press and hold the button longer ten seconds or the garage door opener will switch to programming mode.

### Programming buttons

Applies to: vehicles with garage door opener (HomeLink)

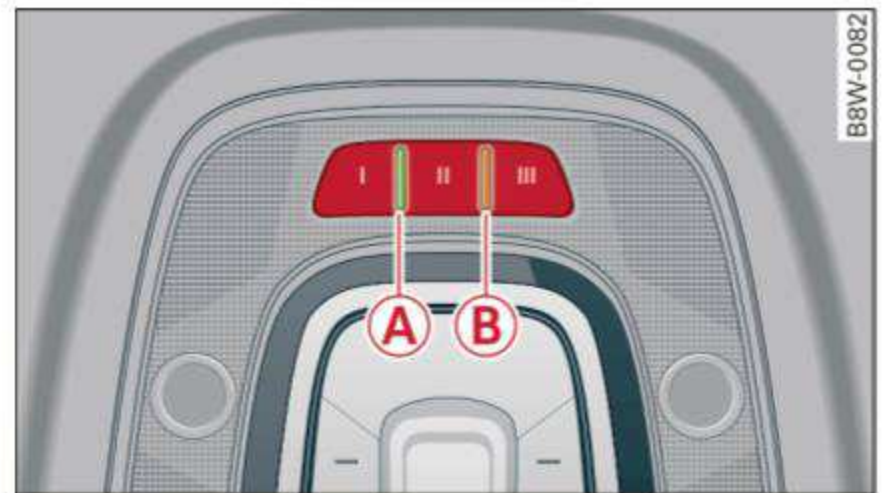

Fig. 36 Headliner: controls

You can program both fixed code and rolling code systems using this procedure.

### Programming/reprogramming buttons

Requirement: the vehicle must be in range of the system, such as the garage door, that you would like to program.

- ▶ Switch the ignition on.
- ▶ Press and hold the button in the headliner that you would like to program for at least two seconds. Or
- ▶ Select in the Infotainment system: **MENU** button > **Vehicle** > left control button > **Vehicle settings** > **Garage door opener** > **Program garage door opener** > **Program button I/Program** ▶

**button II/Program button III** (reprogram).

The yellow LED **B** blinks.

- ▶ Follow the instructions in the Infotainment system.

### Synchronizing a button<sup>1)</sup>

Requirement: the button must already be programmed and must be synchronized with the system that you would like to program.

- ▶ Switch the ignition on.
- ▶ Press the button in the headliner that you would like to synchronize.
- ▶ Follow the instructions in the Infotainment system.

### Deleting button programming

The programmed buttons cannot be deleted individually. They must be deleted all at once. Reprogram the buttons if necessary.

- ▶ Switch the ignition on.
- ▶ Select in the Infotainment system: **MENU** button > **Vehicle** > left control button > **Vehicle settings** > **Garage door opener** > **Delete button programming** > **Yes, delete now**.

### Displaying the version/status/country code

- ▶ Select in the Infotainment system: **MENU** button > **Vehicle** > left control button > **Vehicle settings** > **Garage door opener** > **Version information**.

#### **Tips**

- The garage door opener may need to be synchronized with the system motor after the programming. Follow the manufacturer's instructions for doing this.
- The programming process can take up to 30 seconds. The hand transmitter may need to be operated again during the process.
- Make sure the batteries in the hand transmitter are charged before starting the programming process.
- In some cases, the system must be programmed using an alternative mode. Select in the Infotainment system: **MENU** > **Vehi-**

**cle** > left control button > **Vehicle settings** > **Garage door opener** > **Program garage door opener** > right control button > **UR-Mode/D-Mode**.

---

<sup>1)</sup> Only applies to rolling code systems

## Lights and Vision

### Exterior lighting

#### Switching the lights on and off



Fig. 37 Instrument panel: light switch with buttons

#### Light switch ☀

Turn the light switch to the corresponding position when the ignition is switched on. ☀ and the selected position turn on (except position 0).

0 - The daytime running lights automatically turn on. In vehicles for certain markets, you can switch the automatic daytime running lights on and off in the Infotainment system\*.

AUTO - The headlights automatically adapt to the surrounding brightness.

☀ - Parking lights

☀ - Low beam headlights

#### Buttons

When you turn the light switch to the AUTO or low beam headlight position ☀, you can activate the following functions:

☀ - All-weather lights. The headlights automatically adjust so that there will be less glare, for example when the road surface is wet.

☀ - Rear fog lights

#### Automatic headlight range control system

Your vehicle is equipped with an automatic headlight range control system that reduces glare for oncoming traffic if the vehicle load changes. The headlight range adjusts automatically.

#### Audi adaptive light

Applies to: vehicles with adaptive light

Adaptive light provides better visibility when it is dark by adapting the lights to the road conditions based on speed, such as on expressways, rural roads, at intersections, and in curves. The adaptive light only functions when the light switch is in the AUTO position.

#### ⚠ WARNING

- Automatic headlights\* are only intended to assist the driver. They do not relieve the driver of responsibility to check the headlights and to turn them on manually based on the current light and visibility conditions. For example, fog cannot be detected by the light sensors. So always switch on the low beams under these weather conditions and when driving in the dark ☀.
- To prevent glare for traffic behind your vehicle, the rear fog lights should only be turned on in accordance with traffic regulations.
- Always observe legal regulations when using the lighting systems described.

#### i Tips

- The light sensor for the automatic headlights\* is in the rearview mirror mount. Do not place any stickers in this area on the windshield.
- A warning tone will sound if you open the door when the exterior lights are switched on.
- Only the front headlights turn on when the daytime running lights are switched on\*. In vehicles in certain markets, the tail lights will also turn on.
- In cool or damp weather, the inside of the headlights, turn signals and tail lights can fog over due to the temperature difference between the inside and outside. They will clear shortly after switching them on. This does not affect the service life of the lighting.

**Turn signal and high beam lever**

The lever operates the turn signals, the high beams and the headlight flasher.

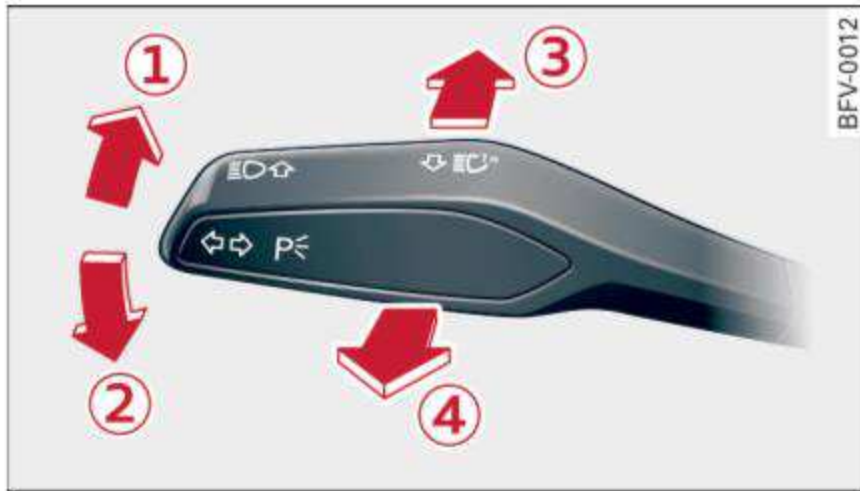

Fig. 38 Turn signal and high beam lever

**Turn signals** ⇐ ⇨

The turn signals activate when you move the lever into a turn signal position when the ignition is switched on.

- ① - Right turn signal
- ② - Left turn signal

The turn signal blinks three times if you just tap the lever.

**High beams and headlight flasher** ☰

Move the lever to the corresponding position:

- ③ - High beams on (vehicles with high beam assistant\* ⇒ page 46)
- ④ - High beams off or headlight flasher

The ☰ indicator light in the instrument cluster turns on.

**! WARNING**

High beams can cause glare for other drivers, which increases the risk of an accident. For this reason, only use the high beams or the headlight flasher when they will not create glare for other drivers.

**High beam assistant**

Applies to: vehicles with high beam assistant

The high beam assistant automatically turns the high beams on or off depending on the surrounding conditions.

A camera on the rearview mirror mount can detect light sources from other road users. The high beams switch on or off automatically depending on the position of vehicles driving ahead and oncoming vehicles, the vehicle speed and other environmental and traffic conditions.

**Activating high beam assistant**

Requirement: the light switch must be set to the AUTO position and the high beam assistant must be switched on in the Infotainment system ⇒ page 47.

- ▶ To activate the high beam assistant, tap the lever forward ③ ⇒ page 46, fig. 38. The indicator light appears in the instrument cluster display and the high beams are switched on/off automatically. If the high beams were completely or partially switched on, the indicator light turns on.

**Switching the high beams on/off manually**

If the high beams did not switch on/off automatically as expected, you may switch them on or off manually instead:

- ▶ To switch the high beams on manually, tap the lever forward ③ ⇒ page 46, fig. 38. The indicator light turns on.
- ▶ To switch the high beams off manually, pull the lever back ④ ⇒ page 46, fig. 38. The high beam assistant is deactivated.

**Operating the headlight flasher**

- ▶ To operate the headlight flasher when the high beam assistant is activated and high beams are switched off, pull the lever back ④ ⇒ page 46, fig. 38. The high beam assistant remains active.

**Messages in the instrument cluster display**

Audi adaptive light: malfunction! See owner's manual

**Headlight assistant: malfunction! See owner's manual**

Drive to an authorized Audi dealer or authorized Audi Service Facility immediately to have the malfunction corrected. You can still switch the high beams on or off manually.

**Headlight assistant: currently unavailable. Camera view restricted due to surroundings. See owner's manual**

The camera view is blocked, for example by a sticker or debris.

The sensor is located between the interior rear-view mirror and the windshield. Do not place any stickers in this area on the windshield.

**! WARNING**

High beam assistant is only intended to assist the driver. The driver is still responsible for controlling the headlights and may need to switch them on and off manually depending on light and visibility conditions. It may be necessary to operate them manually in situations such as:

- In adverse weather conditions such as fog, heavy rain, blowing snow or spraying water.
- On roads where oncoming traffic may be partially obscured, such as expressways.
- When there are road users that do not have sufficient lighting, such as bicyclers or vehicles with dirty tail lamps.
- In tight curves and on steep hills.
- In poorly lit areas.
- With strong reflectors, such as signs.
- If the area of the windshield near the sensor is fogged over, dirty, icy or covered with a sticker.

**Adjusting the exterior lighting**

The functions are adjusted in the Infotainment system.

- ▶ Select in the Infotainment system: **MENU** button > **Vehicle** > left control button > **Vehicle settings** > **Exterior lighting**.

**Automatic headlights**

You can adjust the following settings in the **Automatic headlights** menu:

**Activation time** - you can adjust if the automatic headlights switch on **Early**, **Medium** or **Late** according to the sensitivity of the light sensor.

**Headlight assistant\*** - you can switch the high beam assistant\* on and off.

**Entry/exit lighting**

When it is dark, the **Entry/exit lighting** illuminates the area around the vehicle when unlocking the vehicle and after switching off the ignition and opening the driver's door.

The **Entry/exit lighting** only works when it is dark and the light switch is in the **AUTO** position.

**Daytime running lights**

**USA models:** the daytime running lights can be switched on/off. Select **On** or **Off**.

**Canada models:** this function cannot be switched off. They activate automatically each time the ignition is switched on.

**Emergency flashers**



Fig. 39 Center console: emergency flasher button

The emergency flashers makes other drivers aware of your vehicle in dangerous situations.

- ▶ Press the **△** button to switch the emergency flashers on or off.

You can indicate a lane change or a turn when the emergency flashers are switched on by using the turn signal lever. The emergency flashers stop temporarily.

The emergency flashers also work when the ignition is turned off.

### **i** Tips

You should switch the emergency flashers on if:

- you are the last car in a traffic jam so that all other vehicles approaching from behind can see your vehicle
- your vehicle has broken down or you are having an emergency
- your vehicle is being towed or if you are towing another vehicle

## Interior lighting

### Front interior lighting

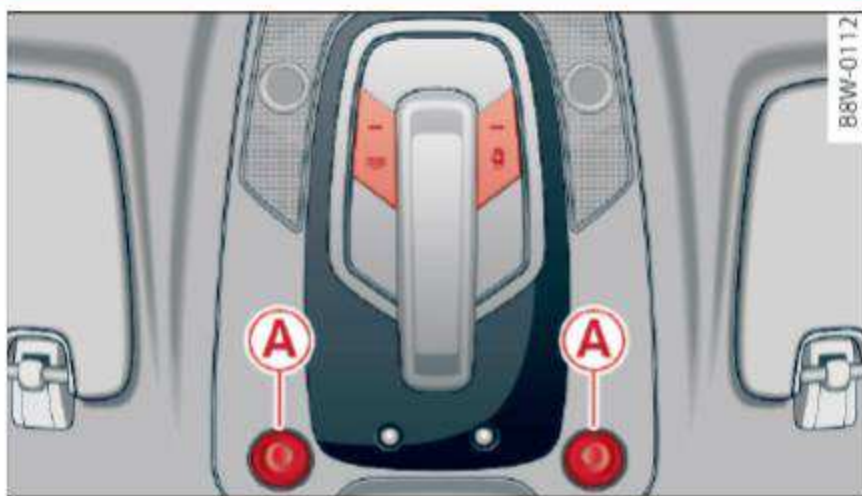



Fig. 40 Headliner: front interior lighting

Press the corresponding button ⇒ *fig. 40*:

 - Door contact switch on/off. The interior lighting is controlled automatically.

 - Interior lighting on/off

Applies to: vehicles with touch-sensitive reading lights: To turn the respective reading light on or off, touch the surface **A** briefly. To activate the manual dimming function, touch the surface **A** when the light is switched off and keep touching it until the desired brightness is reached.

### Rear interior lighting



Fig. 41 Headliner: reading lights, version 1

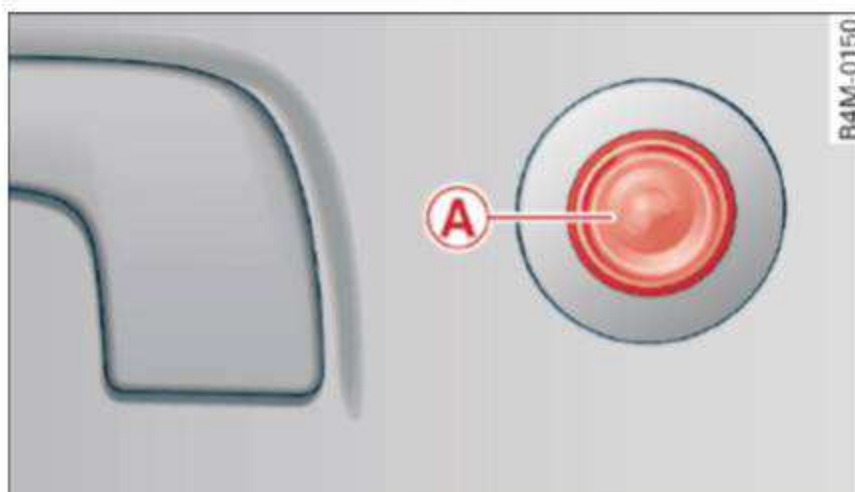



Fig. 42 Headliner: reading lights, version 2

- ▶ **Version 1:** to turn a reading light on or off, press the  button.
- ▶ To activate the manual dimming function\*, touch the surface when the light is switched off  and keep touching it until the desired brightness is reached.
- ▶ **Version 2 (touch-sensitive reading lights with manual dimming function\*):** to turn a reading light on or off, briefly touch the surface **A** ⇒ *fig. 42*.
- ▶ To activate the manual dimming function, touch the surface **A** when the light is switched off and keep touching it until the desired brightness is reached.

### Interior lighting

Applies to: vehicles with interior lighting

- ▶ Select in the Infotainment system: **MENU** button > **Vehicle** > left control button > **Vehicle settings** > **Interior lighting**.

The interior lighting turns on when you switch the headlights on while the ignition is on. ▶

**Version 1**

To adjust the brightness of individual zones, select **Front brightness\***, **Door brightness** or **Footwell brightness**. Turn the control knob to the left or to the right. Press the control knob to confirm the brightness.

**Version 2**

Select and confirm one of the displayed profiles by pressing the control knob.

**Individual:** you can customize the brightness and color of individual zones. Press the right control button. Press the control knob again to confirm the settings.

**Audi drive select:** the interior and contour lighting color changes depending on the driving mode selected in drive select\* ⇒ *page 125*.

**i Tips**

The setting is automatically stored and assigned to the remote control key that is being used.

**Instrument illumination**

*The brightness of the illumination for the instruments, display and head-up display\* can be adjusted.*



Fig. 43 Instrument illumination

- ▶ Press the knob to release it.
- ▶ Turn the knob toward "-" or "+" to reduce or increase the brightness.
- ▶ Press the knob again to return it to its original position.

**i Tips**

Depending on vehicle equipment, the instrument illumination (needles and gauges) may turn on when the lights are off and the ignition is switched on. The illumination for the gauges reduces automatically and eventually turns off as brightness outside increases. This function reminds the driver to turn the low beams on at the appropriate time.

**Vision**

**Adjusting exterior mirrors**



Fig. 44 Driver's door: knob for the exterior mirrors

Turn the knob to the desired position:

- 0 - all adjustment functions are deactivated.
- ↔ - adjusting the left/right exterior mirror. Move the knob in the desired direction.
- ☀ - Heats\* the mirror glass depending on the outside temperature.
- ↔ - Folds the exterior mirrors\*. To fold the mirrors out, turn the knob to one of the other positions. In the Infotainment system, you can select if the mirrors fold in automatically when you lock the vehicle ⇒ *page 35*.

**Front passenger's exterior mirror tilt function\***

To help you see the curb when backing into a parking space, the surface of the mirror tilts slightly. For this to happen, the knob must be in the position for the front passenger's exterior mirror.

You can adjust the tilted mirror surface by turning the knob in the desired direction. When you ▶

move out of reverse and into another gear, the new mirror position is stored and assigned to the key you are using.

The mirror goes back into its original position once you drive forward faster than 9 mph (15 km/h) or turn the ignition off.

### **WARNING**

Curved mirror surfaces (for example convex) enlarge the field of vision. However, they make objects in the mirror appear smaller and farther away. You may estimate incorrectly when you use these mirrors to gauge your distance from the vehicles behind you when changing lanes, which increases the risk of an accident.

### **Note**

- Applies to vehicles with power folding exterior mirrors: if the mirror housing was moved by outside forces (such as an impact when maneuvering), you must use the power folding function to fold the mirror all the way out. The mirrors will make a loud noise when they latch into place. The mirror housing must not be moved back into place by hand because this would impair the function of the mirror mechanism.
- Applies to vehicles without power folding exterior mirrors: if the mirror housing was moved by outside forces (such as an impact when maneuvering), you must move it back in place by hand.
- If you wash the vehicle in an automatic car wash, you must fold the exterior mirrors in to reduce the risk of damage to the mirrors. Never fold power folding exterior mirrors\* by hand. Only fold them in and out using the power controls.

### **Tips**

- If the power adjusting function malfunctions, the glass in both mirrors can be adjusted by pressing on the edge of it by hand.
- The exterior mirror settings are stored with the memory function\* ⇒ *page 59*.

## Dimming the mirrors

*Your vehicle is equipped with a manual or automatic\* dimming rearview mirror.*

### Manual dimming rearview mirror

- ▶ Pull the lever on the bottom of the mirror back.

### Automatic dimming rearview mirror\*

- ▶ The interior and exterior mirrors dim automatically when light shines on them, for example from headlights on a vehicle behind you.

### **WARNING**

If the glass on an automatic dimming mirror breaks, electrolyte can leak out. This liquid can irritate the skin, eyes and respiratory system. If there is contact with the fluid, flush immediately with plenty of water. Consult a physician if necessary.

- Repeated or long-term exposure to electrolyte fluid can lead to irritation of the airways, especially in people with asthma or other respiratory conditions. Take deep breaths immediately after leaving the vehicle or, if this is not possible, open all of the doors and windows as wide as possible.
- If electrolyte fluid enters the eyes, flush them thoroughly with a large amount of clean water for at least 15 minutes and then seek medical attention.
- If electrolyte fluid comes into contact with the skin, flush the affected area with clean water for at least 15 minutes and then clean with soap and water and seek medical attention. Clean affected clothing and shoes thoroughly before wearing again.
- If the fluid was swallowed and the person is conscious, flush the mouth with water for at least 15 minutes. Do not induce vomiting unless this is recommended by medical professionals. Seek medical attention immediately.

### **Note**

If the glass on an automatic dimming mirror breaks, electrolyte can leak out. This liquid damages plastic surfaces and paint. Clean

this liquid as quickly as possible, for example with a wet sponge.

**i Tips**

- If the light reaching the rearview mirror is obstructed, the automatic dimming mirror will not function correctly,
- The automatic dimming mirrors do not dim when the interior lighting is turned on or the reverse gear is selected.

**Sun visors**



Fig. 45 Sun visor

**Sun visor**

The sun visors for the driver and front passenger can be released from their mounts and turned toward the doors ⇨ fig. 45 ①.

They can also be moved back and forth lengthwise in this position.

**Vanity mirror**

The -mirror lighting- switches on when the cover over the vanity mirror 2\* opens.

**Sunshade**

Applies to: vehicles with sunshade



Fig. 46 Rear door: sunshade

**Rear door sunshade**

- ▶ Pull the sunshade out and attach it to the retainer on the upper door frame ⇨ fig. 46.

**Windshield wipers**

**Switching the wipers on**

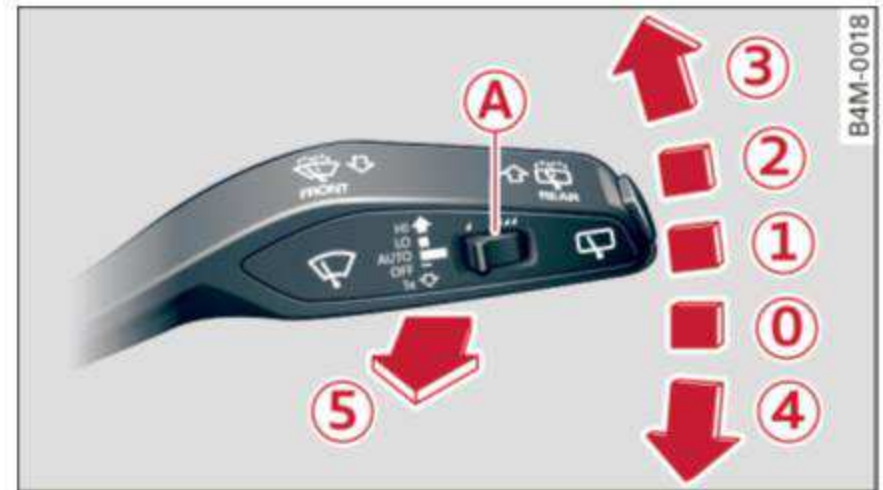

Fig. 47 Windshield wiper lever



Fig. 48 Rear window wiper operation

Move the windshield wiper lever to the corresponding position:

- ① - Windshield wipers off
- ② - Rain sensor mode. The windshield wipers switch on once the vehicle speed exceeds approximately 2 mph (4 km/h) and it is raining. The higher the sensitivity of the rain sensor that is set (switch A to the right), the earlier the windshield wipers react to moisture on the windshield. You can deactivate the rain sensor mode in the Infotainment system, which switches the intermittent mode on. To do this, select: **MENU** button > **Vehicle** > left control button > **Driver assistance** > **Rain sensor**. In intermittent mode, you can adjust the interval time using the switch A.
- ③ - Slow wiping

- ③ - Fast wiping
- ④ - Single wipe. If you hold the lever in this position longer, the wipers switch from slow wiping to fast wiping.
- ⑤ - Clean the windshield. The wipers wipe one time after several seconds of driving to remove water droplets. You can switch this function off by moving the lever to position ⑤ within 10 seconds of the afterwipe. The afterwipe function is reactivated the next time you switch the ignition on.

Clean the headlights\*. The headlight washer system\* operates only when the low beam headlights are on. If you move the lever into position ⑤, the headlights will be cleaned at fixed intervals.

- ⑥ - Wipe the rear window. The number of wipes depends on the windshield wiper movement.

The rear wiper automatically switches on when the reverse gear is selected and the front windshield wipers are on and running.

- ⑦ - Clean the rear window. The number of wipes depends on how long the lever is held in position ⑦. This may also clean the rearview camera, depending on the vehicle equipment.

### WARNING

- The rain sensor is only intended to assist the driver. The driver may still be responsible for manually switching the wipers on based on visibility conditions.
- The windshield may not be treated with water-repelling windshield coating agents. Unfavorable conditions, such as wetness, darkness or low sun, can result in increased glare, which increases the risk of an accident. Wiper blade chatter is also possible.
- Properly functioning windshield wiper blades are required for a clear view and safe driving ⇒ *page 53, Replacing wiper blades.*

### Note

- If there is frost, make sure the windshield wiper blades are not frozen to the wind-

shield. Switching on the windshield wipers when the blades are frozen to the windshield can damage the wiper blades.

- The windshield wiper system must be switched off (lever in position 0) before using a car wash. This prevents the wipers from switching on unintentionally and causing damage to the windshield wiper system.

### Tips

- The windshield wipers switch off when the ignition is switched off. You can activate the windshield wipers after the ignition is switched back on by moving the windshield wiper lever to any position.
- Worn or dirty windshield wiper blades result in streaking. This can affect the rain sensor function. Check your windshield wiper blades regularly.
- The washer fluid nozzles for the windshield washer system are heated at low temperatures when the ignition is on.
- When stopping temporarily, such as at a traffic light, the speed of the windshield wipers automatically reduces by one level.

## Cleaning the wiper blades

Clean the wiper blades when you see wiper streaks. Use a soft cloth and a glass cleaner.

### Windshield wiper

- ▶ Place the windshield wiper arms in the service position ⇒ *page 53.*
- ▶ Fold the windshield wiper arms away from the windshield.

### Rear window wiper

- ▶ Fold the wiper arm away from the rear window.

### WARNING

Dirty windshield wiper blades can impair vision, which increases the risk of an accident.

## Replacing wiper blades

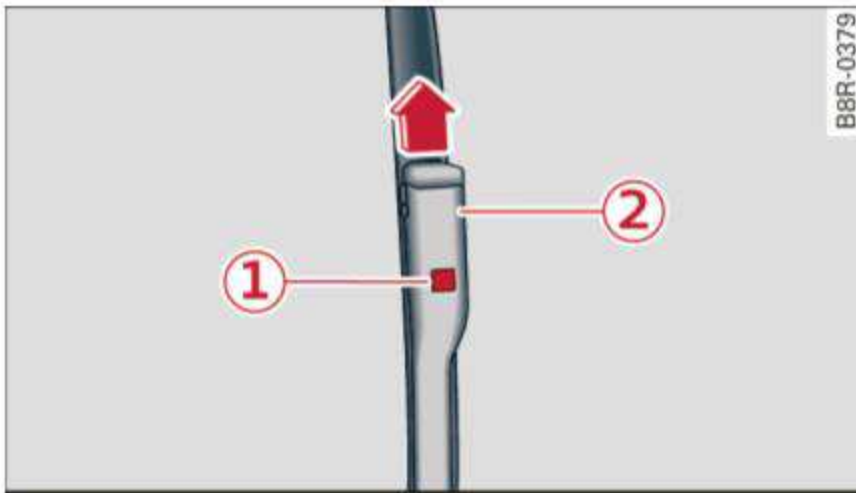

Fig. 49 Removing windshield wiper blades

### Windshield wiper service position/blade replacement position

- ▶ To bring the windshield wipers into the service position, turn the ignition off and move the windshield wiper lever into position ④ ⇒ page 51, fig. 47.
- ▶ To bring the windshield wipers back to the normal position, switch the ignition on and hold the windshield wiper lever in position ④ until the windshield wipers go back to the normal position, or drive faster than 8 mph (12 km/h).

You can also turn the service position on or off in the Infotainment system:

- ▶ Switch the windshield wipers off (position ① ⇒ page 51, fig. 47).
- ▶ Select: the **MENU** button > **Vehicle** > left control button > **Service & checks** > **Wiper change position**.

### Removing the wiper blade

- ▶ Fold the windshield wiper arm away from the windshield.
- ▶ Press the locking knob ① ⇒ fig. 49 on the wiper blade. Hold the wiper blade firmly.
- ▶ Remove the wiper blade in the direction of the arrow.

### Installing the wiper blade

- ▶ Insert the new wiper blade into the mount on the wiper arm ② until it clicks into place.
- ▶ Place the wiper arm back on the windshield.
- ▶ Turn the service position off.

### ⚠ WARNING

For safety reasons, the windshield wiper blades should be replaced once or twice each year.

### ⓘ Note

- Only fold the windshield wipers away when they are in the service position. Otherwise, you risk damaging the paint on the hood or the windshield wiper motor.
- You should not move your vehicle or operate the windshield wiper lever when the wiper arms are folded away from the windshield. The windshield wipers would move back into their original position and could damage the hood and windshield.
- To reduce the risk of damage to the wiper system, always loosen blades which are frozen to the windshield before operating the wipers.
- To reduce the risk of damage to the wiper blades, do not use gasoline, kerosene, paint thinner, or other solvents on or near the wiper blades.
- To reduce the risk of damage to the wiper arms or other components, do not attempt to move the wipers by hand.

### ⓘ Tips

- You can also use the service position, for example, if you want to protect the windshield from icing by using a cover.
- You cannot activate the service position when the hood is open.

## Replacing rear wiper blade



Fig. 50 Rear window wiper: installing the wiper blade

### Removing the wiper blade

- ▶ Fold the wiper arm away from the rear window.
- ▶ Remove the wiper blade from its holder.

### Installing the wiper blade

- ▶ Press the wiper blade mount into the retainer.
- ▶ Fold the window wiper arm back onto the rear window.

#### **WARNING**

For safety reasons, the windshield wiper blades should be replaced once or twice each year.

- ▶ To turn the compass on or off, press the button  until the compass in the mirror appears or disappears.

The digital compass only works when the ignition is turned on. The directions are indicated with abbreviations: **N** (north), **NE** (northeast), **E** (east), **SE** (southeast), **S** (south), **SW** (southwest), **W** (west), **NW** (northwest).

#### **Tips**

To prevent inaccurate compass readings, do not bring any remote controls, electrical devices or metallic objects near the mirror.

## Digital compass

### Switching the compass on and off

Applies to: vehicles with digital compass

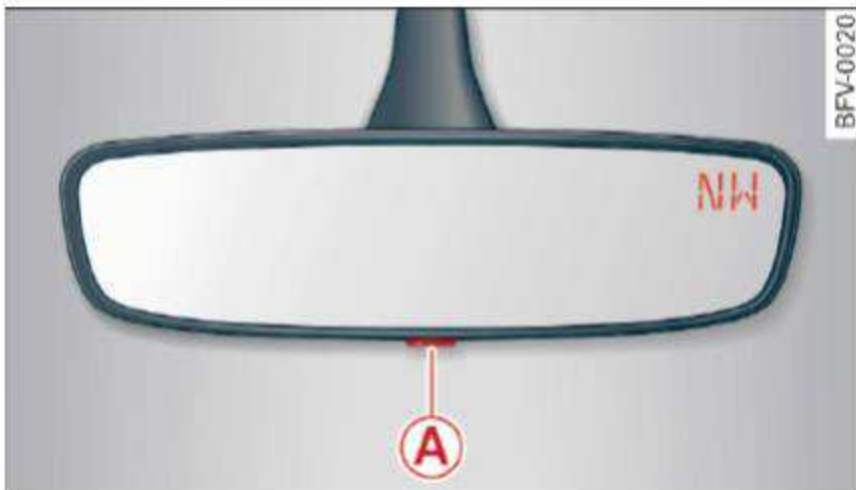

Fig. 51 Rearview mirror: digital compass is switched on

## Adjusting the magnetic zone

Applies to: vehicles with digital compass

*The magnetic zone must be adjusted correctly for the compass to read accurately.*

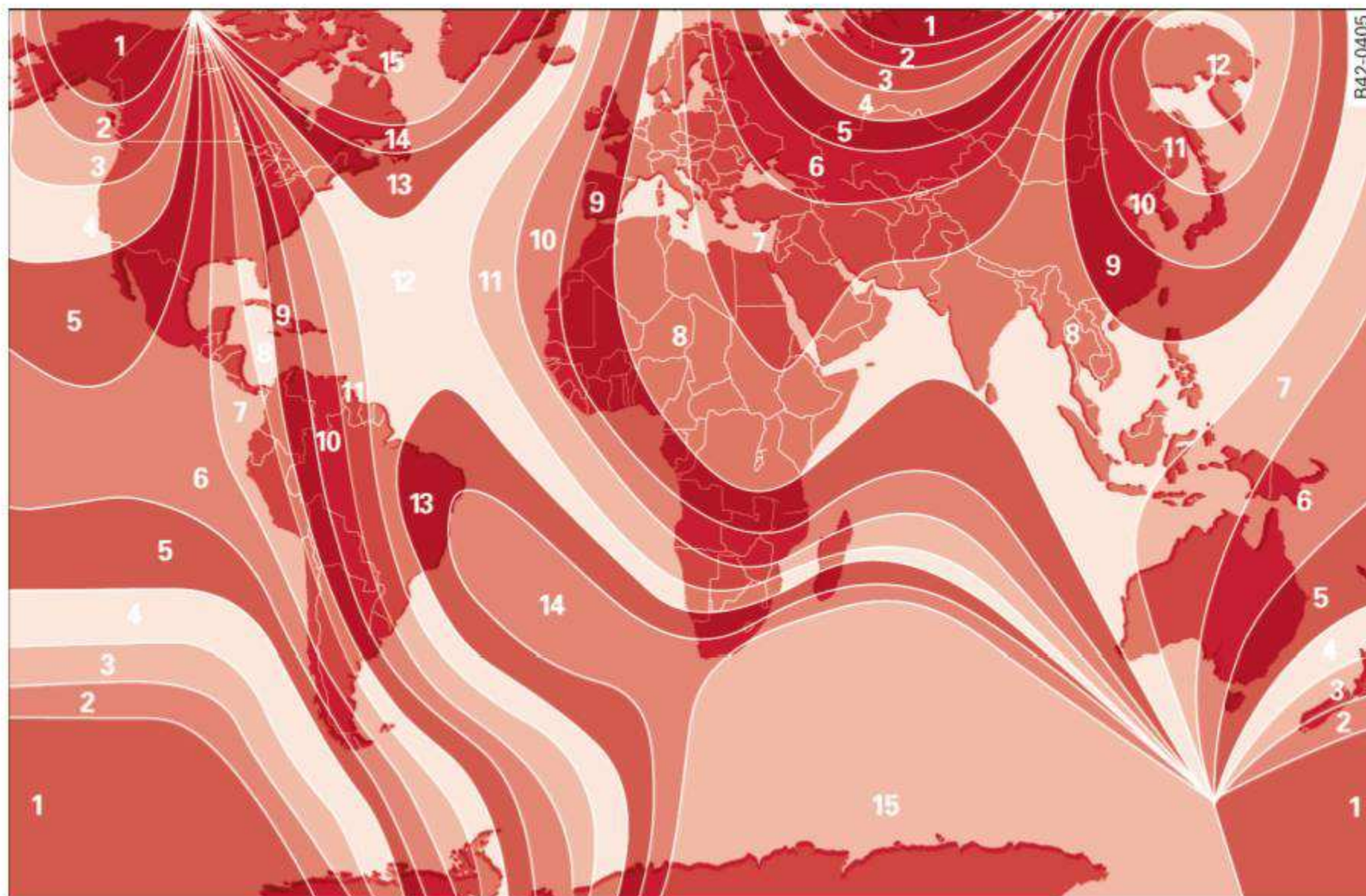

Fig. 52 Magnetic zone map

- ▶ Press and hold the button **(A)** ⇨ *page 54, fig. 51* until the number of the selected magnetic zone appears in the rearview mirror.
- ▶ Press the button **(A)** repeatedly to select the correct magnetic zone. The selection mode turns off after a few seconds.

### **!** WARNING

To reduce the risk to yourself and other drivers, calibrate the compass in an area where there is no traffic.

## Calibrating the compass

Applies to: vehicles with digital compass

*If the display is incorrect or inaccurate, the compass must be recalibrated.*

- ▶ Press and hold the button **(A)** until a **C** appears in the interior rearview mirror.
- ▶ Drive in a circle at about 6 mph (10 km/h) until a direction is displayed in the interior rearview mirror.

## Seats and storage

### General information

#### WARNING

See ⇒ page 252, *Driving safety* for important information, tips, suggestions and warnings that you should read and follow for your own safety and the safety of your passengers.

### Front seats

#### Power seat adjustment

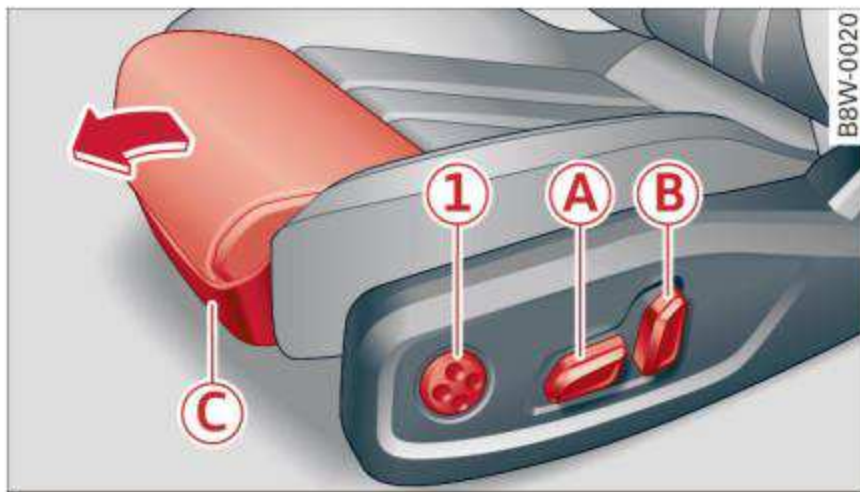

Fig. 53 Front seat: adjusting the seat (version A)

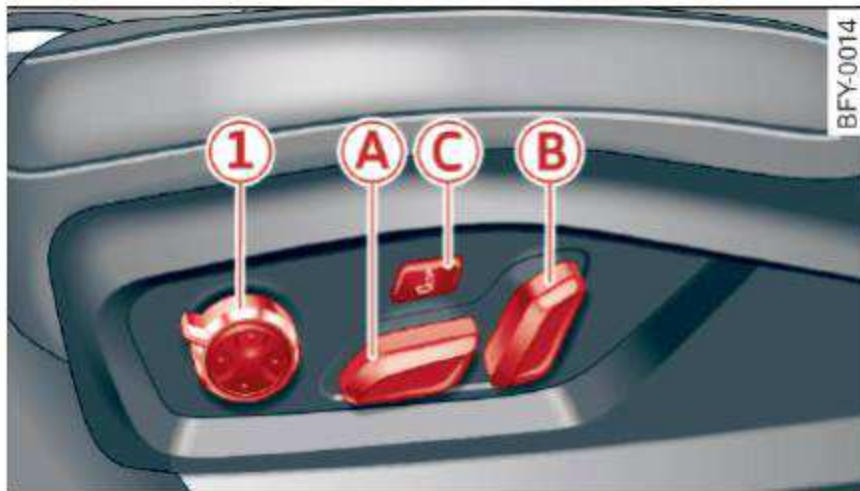

Fig. 54 Front seat: adjusting the seat (version B)

**A** - Moving the seat forward/back: press the button forward/back.

**A** - Moving the seat up/down: press the button up/down. To adjust the front seat cushion, press the front button up/down. To adjust the rear seat cushion, press the rear button up/down.

**B** - Adjusting the backrest angle: press the button forward/back.

**C** - Lengthening/shortening the upper thigh support ⇒ fig. 53. Lift the grip handle. A spring moves the support forward.

**C** - Switching the massage function\* on/off ⇒ fig. 54. Select the type of massage with the multifunction button\* ⇒ page 56.

**1** - Lumbar support\* or multifunction button\* ⇒ page 56. To adjust the lumbar support, press the button in the applicable location.

#### WARNING

- The power front seats can also be adjusted when the ignition is switched off. To reduce the risk of injury, children should never be left unattended in the vehicle for this reason.
- To reduce the risk of an accident, only adjust the driver's seat when the vehicle is stationary.
- Exercise caution when adjusting the seat height. Unsupervised or careless seat adjustment can pinch fingers or hands, which increases the risk of injury.
- The front seat backrests must not be reclined too far back when driving, because this impairs the effectiveness of the safety belts and airbag system, which increases the risk of injury.

#### Multifunction button

Applies to: vehicles with multifunction button

You can adjust the massage function and lumbar support using the multifunction button.

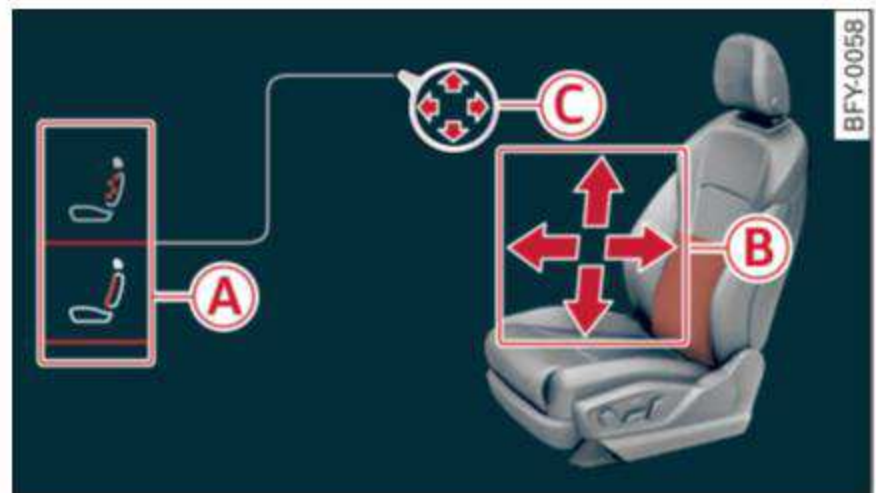

Fig. 55 Infotainment system: seat settings

#### Operating

- If you turn the multifunction button **1** ⇒ page 56, fig. 54 to the left or to the right, the possible seat settings **A** are shown in the Infotainment system ⇒ fig. 55.

- ▶ To select a seat setting, turn the multifunction button **1** in the corresponding direction until the desired seat setting is outlined in red.
- ▶ The arrows **B** represent the possible adjustments. For example, to lower the lumbar support, press the multifunction button **1** down. The corresponding arrow **C** lights up.

The following seat settings **A** are possible:

**Massage function\*** - select the massage type **Wave, Stretch, Knead** or **Off**. You can adjust the intensity of each massage from 1 to 3. You can switch the selected massage on/off using the button **B** ⇒ *fig. 55*.

**Lumbar support** - you can adjust the lumbar support up/down and to be stronger/weaker.

**i Tips**

The massage function switches off automatically after approximately 10 minutes.

**Center armrest**

There is a storage compartment under the armrest.



Fig. 56 Comfort center armrest between the driver's seat and front passenger's seat

- ▶ To adjust the angle, raise the armrest from the starting position notch by notch.
- ▶ To bring the armrest back into the starting position, raise it out of the top notch and fold it back down.

The armrest can slide forward and back.

**Rear seats**

**Adjusting the seats**



Fig. 57 Adjusting the angle of the backrest\*

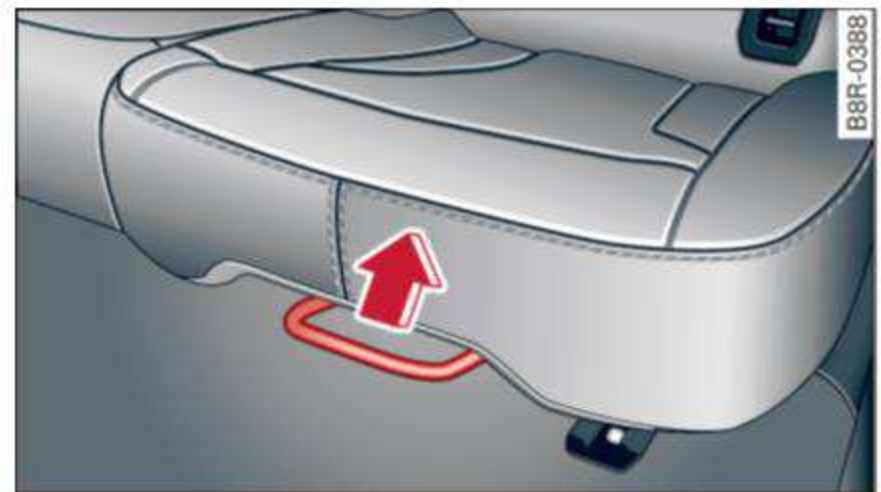

Fig. 58 Adjusting forward and backward\*

**Adjusting the angle of the backrest\***

- ▶ Pull the lever upward and push the backrest back to the desired position ⇒ *fig. 57*. Release the lever and press the backrest farther back until it locks in place.
- ▶ Pull the handle upward so that the backrest will tilt forward. Release the lever and push the backrest back to put the backrest in its basic position.

**Adjusting forward and backward\***

- ▶ Pull the handle up and slide the seat forward/back ⇒ *fig. 58*.
- ▶ Release the handle and continue sliding the seat until it locks in place.

**! WARNING**

- To reduce the risk of an accident, the seat can only be adjusted when the vehicle is stationary.
- Adjusting the seat without paying attention can pinch fingers or limbs, which increases the risk of injury.

## Head restraints

### Front head restraints

Applies to: vehicles with adjustable head restraints

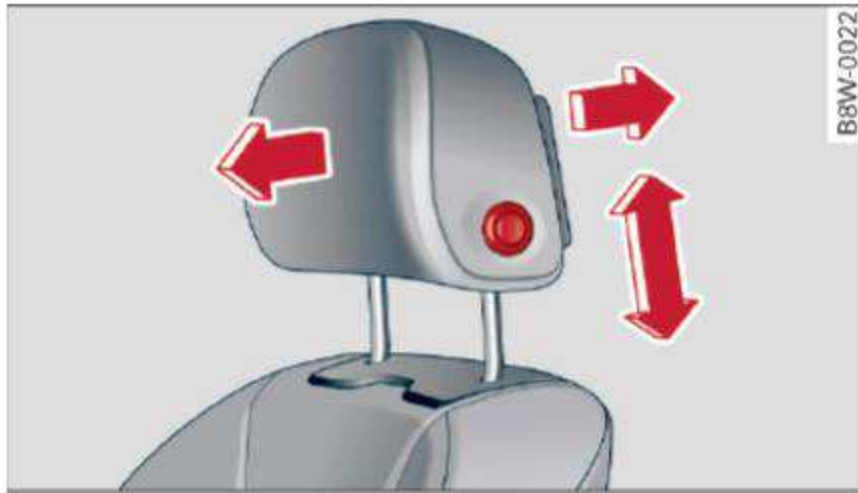

Fig. 59 Front seat: adjusting the head restraint\*

Adjust the head restraints so the upper edge is as even as possible with the top of your head. If that is not possible, try to adjust as close to this position as possible.

### Adjusting the head restraints

- ▶ To move the head restraint upward/forward, hold it at the sides with both hands and slide it upward/forward until you feel it click into place.
- ▶ To move the head restraint downward/backward, press the side button and slide the head restraint downward/backward. Release the button and slide the head restraint farther until it locks into place.

#### WARNING

Always read and follow the applicable warnings ⇒ page 255, *Proper adjustment of head restraints*.

### Rear head restraints

Applies to: vehicles with adjustable head restraints

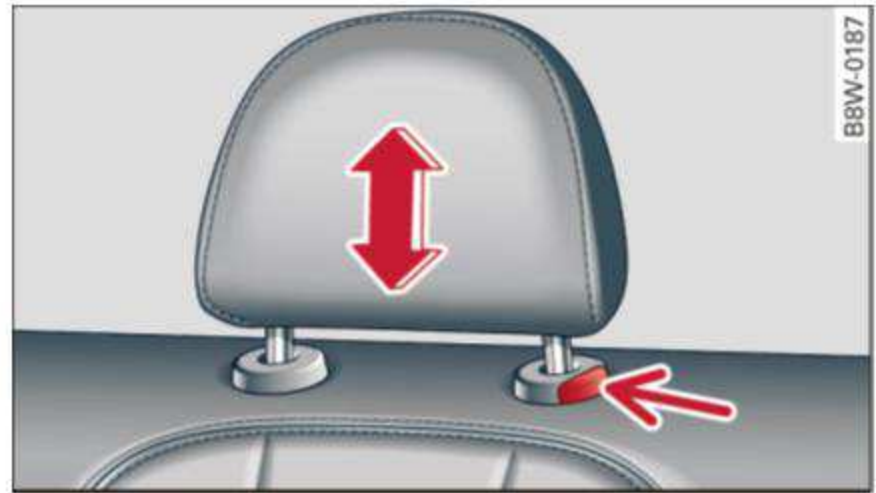

Fig. 60 Rear seat: adjusting the head restraint

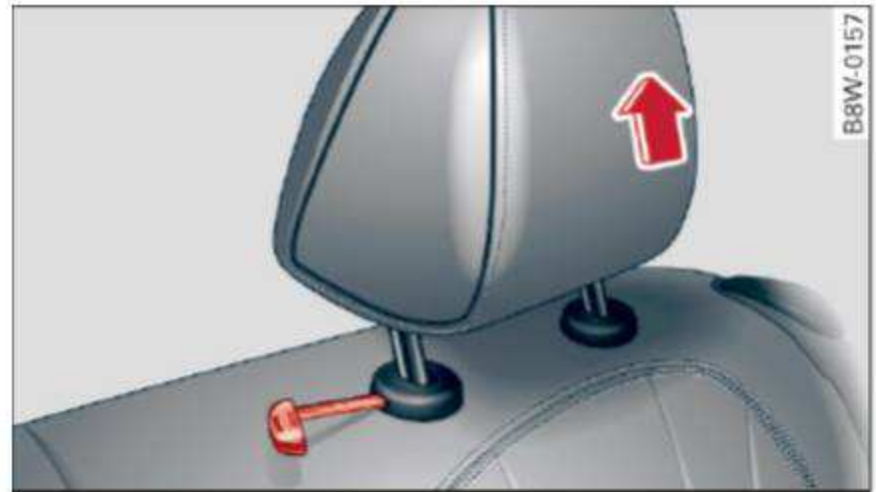



Fig. 61 Rear seat: removing the head restraint

If passengers are sitting in the outer rear seats, adjust the head restraints so that the upper edge of the head restraint is as level as possible with the upper part of their head. If that is not possible, try to adjust as close to this position as possible. If your vehicle has a middle seat, adjust that head restraint all the way up ⇒ .

### Moving the head restraints

- ▶ To move the head restraint upward, hold it at the sides with both hands and slide it upward until it clicks into place ⇒ fig. 60.
- ▶ To move the head restraint down, press the button -arrow- ⇒ fig. 60 and slide the head restraint downward.

### Removing the head restraints

- ▶ Move the head restraint upward as far as it can go.
- ▶ Press the release point ⇒ fig. 61 using the mechanical key ⇒ page 31, *Key set* and press the button -arrow- ⇒ fig. 60. Pull the head restraint out of the backrest at the same time ⇒ .

### Installing the head restraints

- ▶ Slide the posts on the head restraint down into the guides until the posts click into place.
- ▶ Press the button -arrow- ⇒ *fig. 60* and slide the head restraint all the way down. You should not be able to remove the head restraint from the backrest without pressing the button.

#### **WARNING**

- Always read and follow the applicable warnings ⇒ *page 255, Proper adjustment of head restraints.*
- Only remove the head restraints from the rear seats when it is necessary for installing a child safety seat ⇒ *page 291, Child safety.* Install the head restraint again immediately once the child safety seat is removed. Driving with the head restraints removed or not in the upright position increases the risk of serious injury.

## Memory function

### Description

Applies to: vehicles with memory function

Using the memory function, you can quickly and easily store a personal seat profile for the driver and recall the settings later. The memory function is controlled by the remote control key and the memory buttons in the driver's door.

The driver's seat profile is stored again and assigned to the remote control key each time the vehicle is locked. When you open the door, the seat profile is automatically recalled. If two people use the vehicle, it is recommended that each person always uses their "own" remote control key.

Two seat profiles can be stored each using the memory buttons. Once they are stored, these seat profiles can be selected at any time.

The following settings are stored:

	Remote control key	Memory button
	Driver	Driver
Seat	X	X
Both exterior mirrors*	X	X

### Remote control key

Applies to: vehicles with memory function

*The driver's seat profile can be assigned to the remote control key when the vehicle is locked.*

- ▶ Select in the Infotainment system: **MENU** button > **Vehicle** > left control button > **Vehicle settings** > **Seats** > **Driver's seat** > **Store settings on remote control key.**

#### **Tips**

If you do not wish to have the seat profile for another driver assigned to the remote control key, switch the memory function off in the Infotainment system.

### Memory buttons

Applies to: vehicles with memory function



**Fig. 62** Driver's door: memory function buttons

### Storing a seat profile

- ▶ Press the **SET** button. The LED in the button turns on.
- ▶ Press memory button **1** or **2**.

A signal tone will sound when it is successfully stored.

### Accessing a seat profile

- ▶ If the driver's door is open and the ignition is switched off, press the memory button.

## Seats and storage

- ▶ If the driver's door is closed or the ignition is switched on, press and hold the memory button until the seat adjustment is complete.

### WARNING

- For safety reasons, the seat setting can only be recalled when the vehicle is stationary to reduce the risk of an accident.
- In an emergency, seat adjustment operation can be stopped by pressing the **SET** button or the buttons **A** or **B** ⇒ page 56, fig. 54.

## Power sources



Fig. 63 12 volt socket and USB ports\*

When the ignition is switched on, you may be able to use the electric power sources for external devices, depending on the vehicle equipment.

### 12 volt sockets ①

The 12-volt sockets can be used for electrical accessories. The power usage must not exceed 120 watts.

The 12 volt sockets are in the front center console\*, in the rear\* and on the luggage compartment side trim panel\*.

### USB ports ②

You can charge mobile devices and/or connect to the Audi music interface\* using the USB ports\*. For additional information about the USB ports, see ⇒ page 231, *Multimedia connections*.

### WARNING

Incorrect usage can lead to serious injuries or burns. To reduce the risk of injuries, never

leave children unattended in the vehicle with the vehicle key.

### Note

- Disconnect the connectors from the power sources carefully to reduce the risk of damaging them.
- To reduce the risk of damage to the vehicle electrical system, never attempt to charge the vehicle battery by connecting accessories that provide power, such as solar panels or battery chargers, to the power sources.
- To reduce the risk of damage to the power sources, only use plugs and connectors that fit correctly.

## Storage

### Cup holders

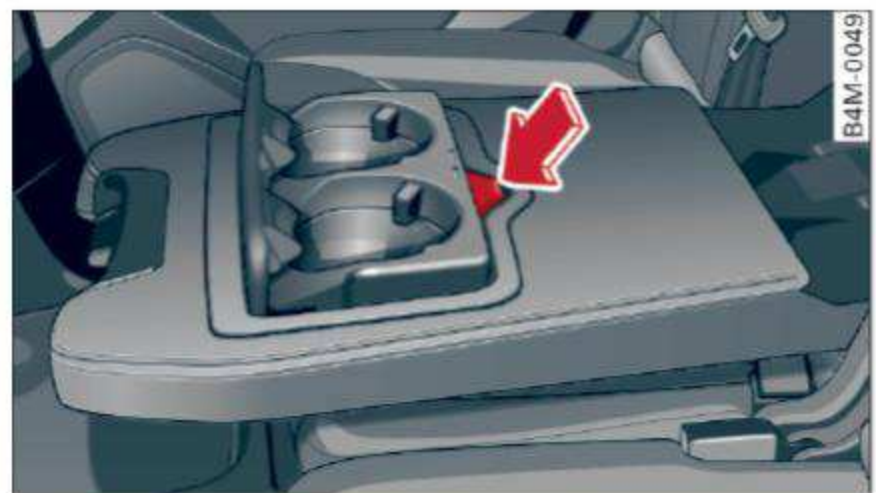

Fig. 64 Rear center armrest: cup holders\*

Your vehicle has cup holders in the front center console and in the center rear seat\*.

### Cup holders in the rear center armrest\*

- ▶ Fold down the center armrest by pressing on the release lever ① ⇒ page 63, fig. 70.
- ▶ Press the button to open the cup holder ⇒ fig. 64.
- ▶ Set your beverage in the holder.
- ▶ To close the cup holder, fold the cover back until it clicks into place.

### WARNING

- Do not put any hot beverages in the cup holder while the vehicle is moving. Hot beverages could spill, which increases the risk of injury.

– Do not use any breakable beverage containers (for example, made out of glass or porcelain). You could be injured by them in the event of an accident.

**! Note**

Beverage containers in the cup holders should always have a lid. If not, beverages could spill and cause damage to vehicle equipment, such as electronics or seat covers.

**Climatized cup holder**

Applies to: vehicles with climatized cup holders



Fig. 65 Center console: climatized cup holder

Press the button to keep your beverage cold ⇒ fig. 65. The LED turns blue ①.

Press the button again to keep your beverage warm ⇒ fig. 65. The LED turns red ②.

To turn off the cooling/heating function, press the button repeatedly until the LED ① and ② turns off.

When cooling, the temperature will reach approximately 38 °F (3 °C). When heating, the temperature will reach approximately 128 °F (53 °C). When the temperature reaches 104 °F (40 °C), the heat indicator ③ also turns on to remind you not to touch the plate when it is too hot. The display turns off if the temperature falls below this value.

**! WARNING**

– To reduce the risk of burns, never touch the beverage holder plate when the heat indicator is on.

– Do not use any breakable beverage containers, such as ones made out of glass or porcelain. You could be injured in the event of an accident.

**! Note**

You should only place sealable beverage containers in the cup holders to avoid damaging vehicle equipment such as vehicle electronics or seat cushions.

**i Tips**

Do not cover the ventilation grille -arrow-, or else the cup holder function may be impaired.

**Cooled glove compartment**

Applies to: vehicles with cooled glove compartment

The cooled glove compartment only functions when the A/C system is switched on.



Fig. 66 Glove compartment: switching cooling mode on/off

- ▶ Turn the knob A counter-clockwise to switch the cooling on.
- ▶ Turn the knob A clockwise to switch the cooling off. The symbols on the knob must appear as they do in ⇒ fig. 66.

If the heating is switched on, switching the glove compartment cooling mode off is recommended.

**Additional storage compartments**

You will find a variety of storage compartments and holders at various locations in the vehicle.

- Glove compartment: the glove compartment can be locked using the mechanical key ⇒ page 31, Key set.

## Seats and storage

- In the door trim panels
- Storage compartment under the front center armrest
- Garment hooks above the rear doors
- Nets\* on the left/right luggage compartment trim panel
- Tie-downs\* on the left/right luggage compartment trim panel
- Bag hooks\* in the luggage compartment

### WARNING

- Always keep the glove compartment lid closed while driving to reduce the risk of injury.
- Only use the storage compartments in the door trim panels to store small objects that will not stick out of the compartment and impair the range of the side airbags.
- Due to strength reasons, only secure objects up to 11 lbs (5 kg) with the tie-downs\*. Heavier objects are not adequately secured. There is risk of personal injury.
- Make sure that the view to the rear is not obstructed by hanging garments.
- Hang only lightweight clothing and be sure that there are no heavy or sharp-edged objects in the pockets.
- Do not use coat hangers to hang the clothing because this could impair the effectiveness of the side curtain airbags.

## Luggage compartment

### General information

### WARNING

Read and follow the important safety precautions in ⇒ *page 257, Storing cargo correctly.*

### Luggage compartment cover

Applies to: vehicles with luggage compartment cover



Fig. 67 Luggage compartment: cover attached



Fig. 68 Luggage compartment: removing and installing the luggage compartment cover

### Attaching

- ▶ Pull the cover out and attach it in the mounting eyelets in the side trim panel ⇒ *fig. 67.*

### Removing

- ▶ Pull both levers in the direction of the arrow ⇒ *fig. 68* and remove the cover upward.

### Installing

- ▶ Place the left and right sides of the cover into the mounts on the side trim panel.
- ▶ Push the cover downward until it clicks into place.

### WARNING

The luggage compartment cover is not a surface for storing objects. Objects placed on the cover could endanger all vehicle occupants during sudden braking maneuvers or in a crash.

**! Note**

Let the luggage compartment cover roll up slowly to reduce the risk of damage.

**Increasing the size of the vehicle interior**

Applies to: vehicles with folding backrests

The rear seat backrests can be folded forward either separately\* or together.

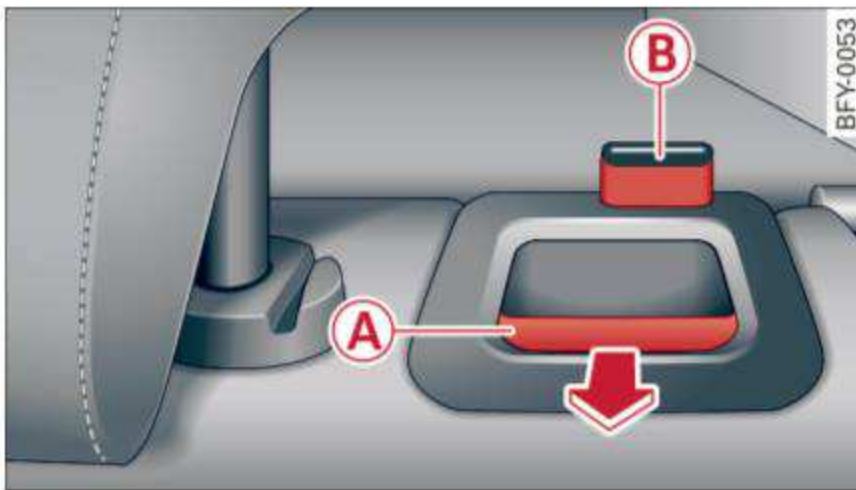

Fig. 69 Outer backrest: release lever and securing knob

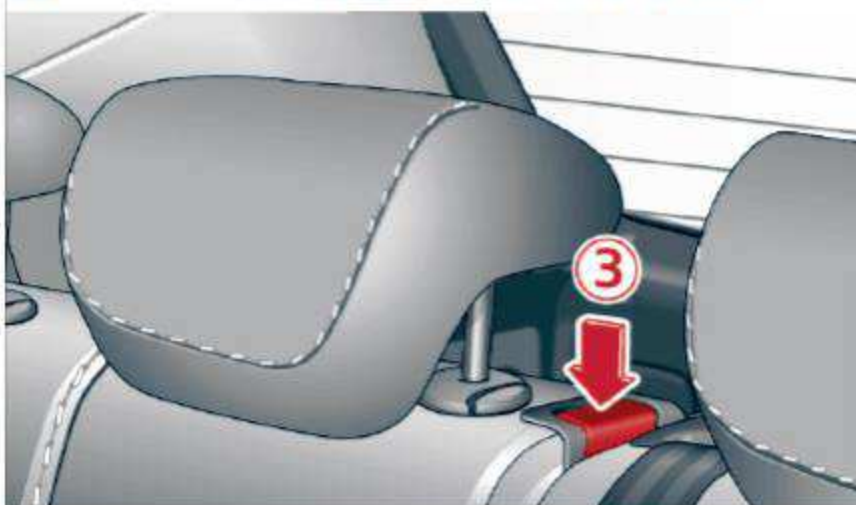
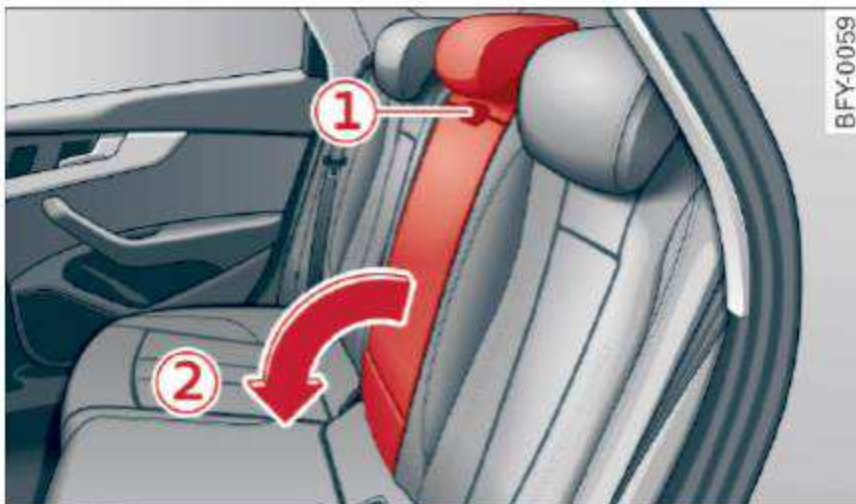

Fig. 70 Center backrest: release lever and release button\*

**Folding the outer rear backrests forward and backward**

- ▶ Pull the release lever **A** ⇒ fig. 69 in the direction of the arrow or pull the lever\* ⇒ page 57, fig. 57 upward. The backrest will swing forward. Allow it to lock into the lowest position.

- ▶ Fold the backrest back up again until it latches or the red marking **B** is no longer visible ⇒ **!**.

**Folding the center rear backrest forward and backward**

- ▶ Pull the upper release lever **1** and fold the backrest forward **2** ⇒ fig. 70 or press the release button\* **3** ⇒ fig. 70 and the red marking on the release button\* will become visible. Fold the backrest forward.
- ▶ Fold the backrest back up again until it locks into place and the red marking is no longer visible ⇒ **!**.

**! WARNING**

- The backrest must be securely latched to ensure the safety belt is protecting the rear seat positions.
- The backrest must be securely latched so objects cannot slide forward out of the luggage compartment during sudden braking.
- Be careful when releasing the backrest and folding it forward. To reduce the risk of being pinched, pay attention and check when folding backrests forward.

**! Note**

- If you move the front seat back when the rear seat backrest is folded forward, you could damage the head restraints on the rear seat.
- To reduce the risk of damage, move the rear head restraints down before folding the rear backrests forward ⇒ page 58.
- Make sure the outer safety belts are not pinched or damaged when folding the seat back.

### Increasing the size of the luggage compartment

The rear seat backrests can be folded forward either separately\* or together.

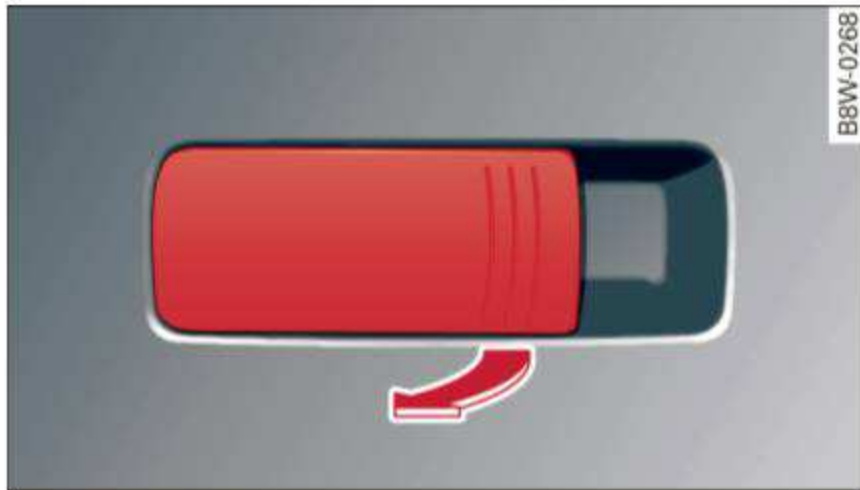

Fig. 71 Luggage compartment: release lever (example)

### Folding the backrest forward

- ▶ Pull the release lever ⇒ *fig. 71* in the direction of the arrow to fold the backrest forward.

### Folding the backrest back into the upright position

- ▶ Fold the backrest back up again until it latches or the red marking ⇒ *page 63, fig. 69* is no longer visible ⇒ ⚠ in *Increasing the size of the vehicle interior on page 63*.

### ⚠ WARNING

- When releasing the rear seat backrest, make sure there are no people or animals within its range of motion. The backrest will fold forward automatically after it is released.
- Be careful when releasing the backrest and folding it forward. To reduce the risk of being pinched, pay attention and check when folding backrests forward.

### ! Note

To reduce the risk of damage, move the rear head restraints down before folding the rear backrests forward ⇒ *page 58*.

### Partition net

Applies to: vehicles with partition net

The partition net prevents objects from sliding from the luggage compartment into the passenger compartment.

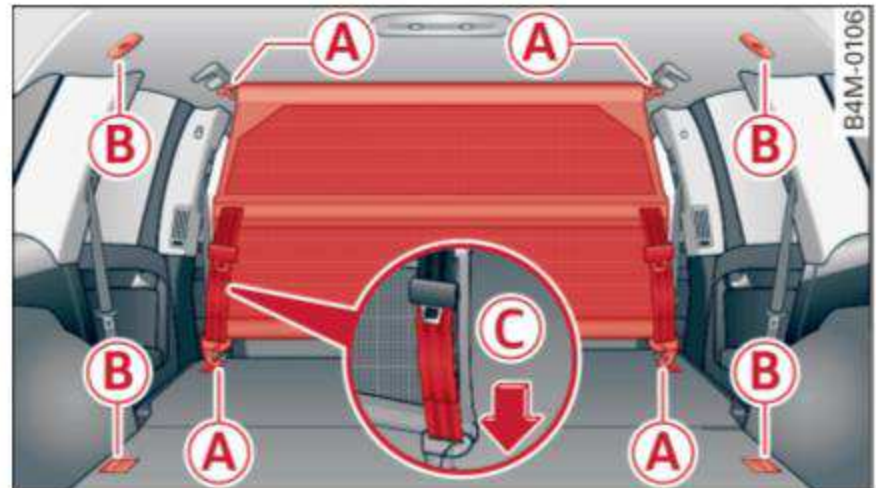

Fig. 72 Folded backrest: attaching the partition net

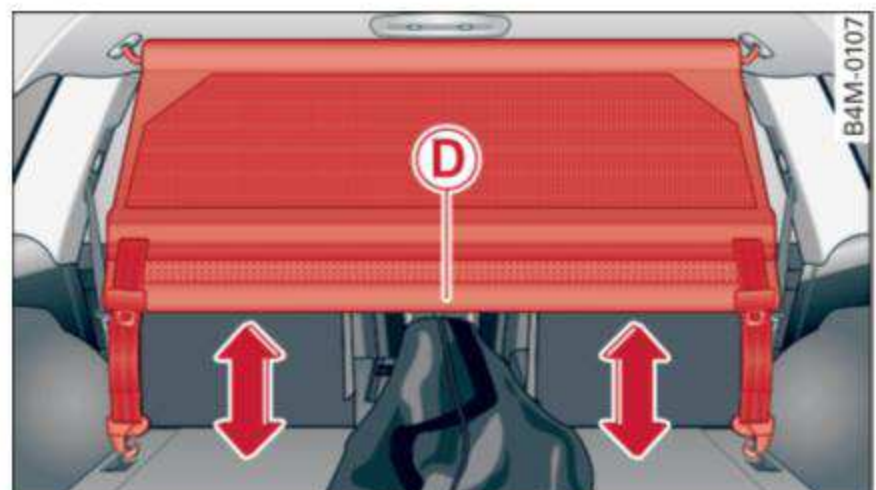

Fig. 73 Behind the backrest: positioning the partition net

### Attaching

- ▶ Attach the partition net to the top mounting eyelets first and then at the bottom eyelets (B) ⇒ *fig. 72*.
- ▶ Tighten and secure the straps (C).

### Attaching with the backrests folded down

- ▶ Fold the backrests down ⇒ *page 63*.
- ▶ Attach the partition net to the mounting eyelets (A) ⇒ *fig. 72*.
- ▶ Tighten and secure the straps (C).

### Positioning

- ▶ Position the partition net at the desired height (D) ⇒ *fig. 73*.

### Removing

- ▶ Loosen the straps (C).
- ▶ Disengage the partition net.

The height of the partition net can be adjusted. This allows you to transport long objects using the cargo pass-through, while keeping the partition net attached at the same time.

**i Tips**

- The straps must face toward the rear when attaching the partition net.
- You must disengage the partition net before folding the backrest back into the upright position.
- The partition net can also be attached to the adjustable tie-downs\* ⇒ page 65.

**Tie-downs and luggage compartment net**

Applies to: vehicles with tie-downs and luggage compartment net

The cargo net prevents small objects from sliding.

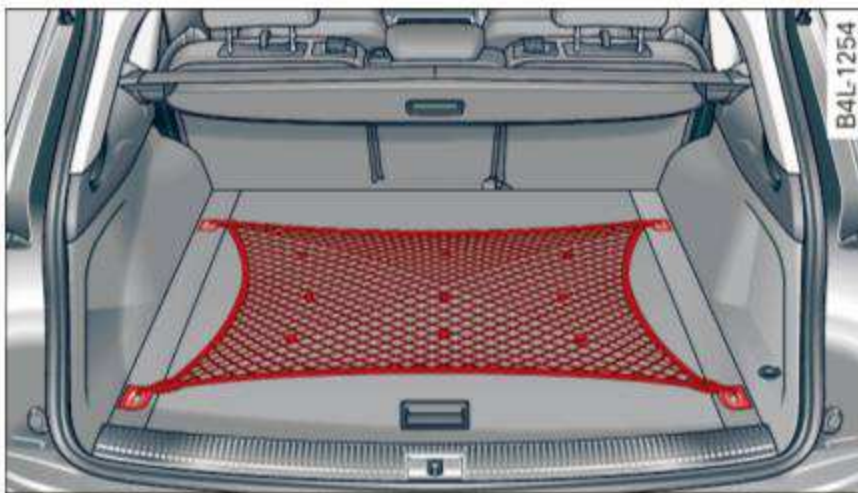

Fig. 74 Luggage compartment: cargo net stretched out

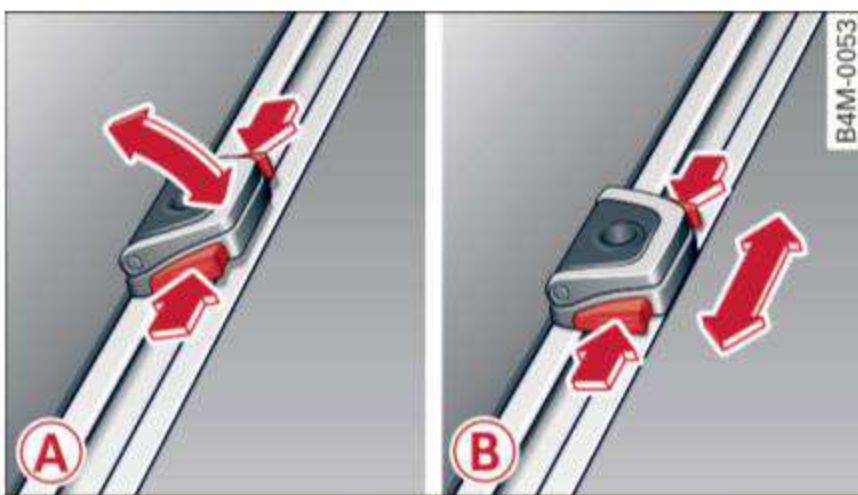

Fig. 75 Luggage compartment: adjustable\* tie-downs

**Fixed tie-downs**

- ▶ Attach the hooks for the luggage compartment net in the tie-downs ⇒ fig. 74.

**Removing and installing adjustable tie-downs\***

- ▶ To install the tie-downs, press both buttons at the sides and insert the tie-down in the rail (A) ⇒ fig. 75.
- ▶ To remove the tie-downs, press both buttons at the sides and remove the tie-down from the rail.
- ▶ To secure the luggage compartment net, fold the tie-down retainer upward.
- ▶ Attach the hooks for the luggage compartment net in the tie-downs.

**Sliding the adjustable tie-downs\***

- ▶ To slide the tie-downs, press both of the side buttons and slide the tie-downs to the desired position (B) ⇒ fig. 75.

**Fixture set**

Applies to: vehicles with a fixture set

The securing attachments prevent objects in the luggage compartment from sliding back and forth.

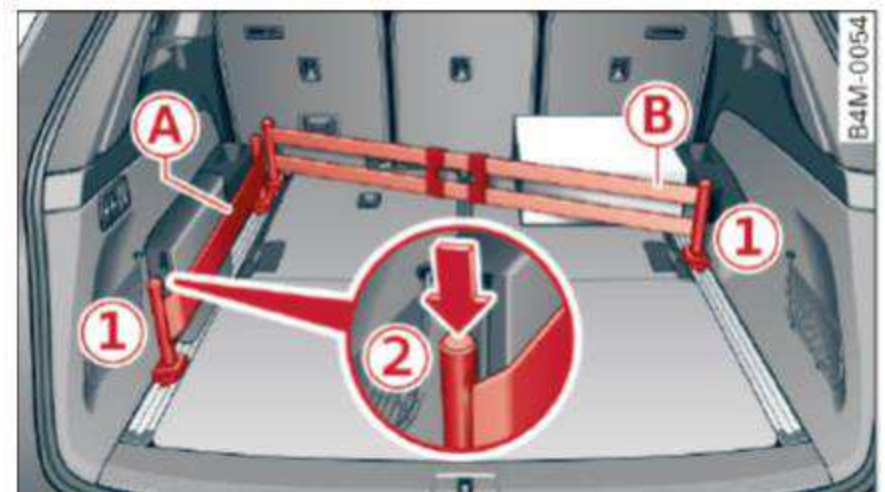

Fig. 76 Luggage compartment: securing attachments

Make sure the backrests are folded upright and the partition net is installed ⇒ page 64.

**Installing the securing strap (A)**

- ▶ Insert the tie-downs ⇒ page 65.
- ▶ Press the button (2) on the retainers (1) and place them on the tie-downs ⇒ fig. 76.
- ▶ Make sure the brackets are locked into place.
- ▶ Slide the tie-downs in order to move the securing strap to the desired position ⇒ page 65.
- ▶ Press the button (2) to tighten the securing straps.

### Installing telescoping rod **B**

- ▶ Insert the tie-downs ⇒ *page 65*.
- ▶ Press the button **2** on the retainers **1** and place them on the tie-downs ⇒ *fig. 76*.
- ▶ Make sure the brackets are locked into place.
- ▶ Slide the tie-downs in order to move the telescoping rod to the desired position ⇒ *page 65*.
- ▶ Press the bracket **1** downward **2** and, using your other hand, slide the lower area to the desired position.
- ▶ Make sure the brackets are locked into place.

#### **!** WARNING

- The backrest must be securely latched so objects cannot slide forward out of the luggage compartment during sudden braking.
- Loose objects in the passenger compartment can fly forward during abrupt maneuvers or accidents and can injure occupants.

### Folding cargo mat

Applies to: vehicles with cargo mat

*The cargo mat protects the luggage compartment and bumper from dirt and scratches.*

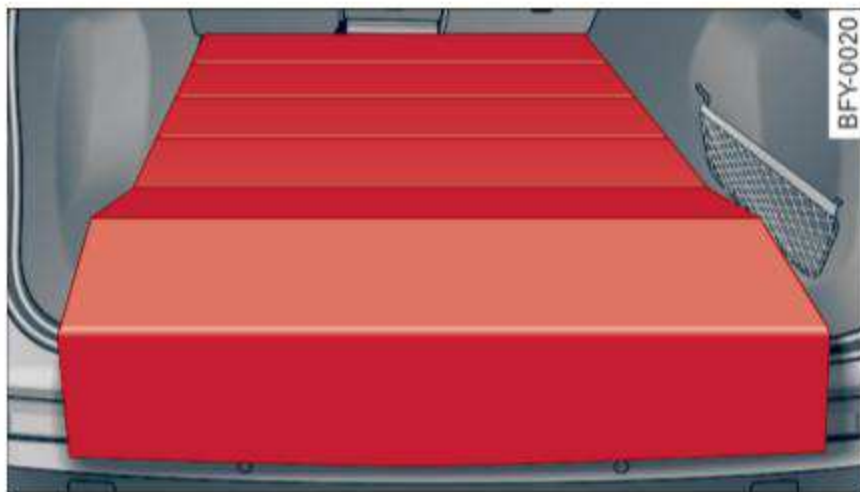

**Fig. 77** Luggage compartment: cargo mat spread out lengthwise

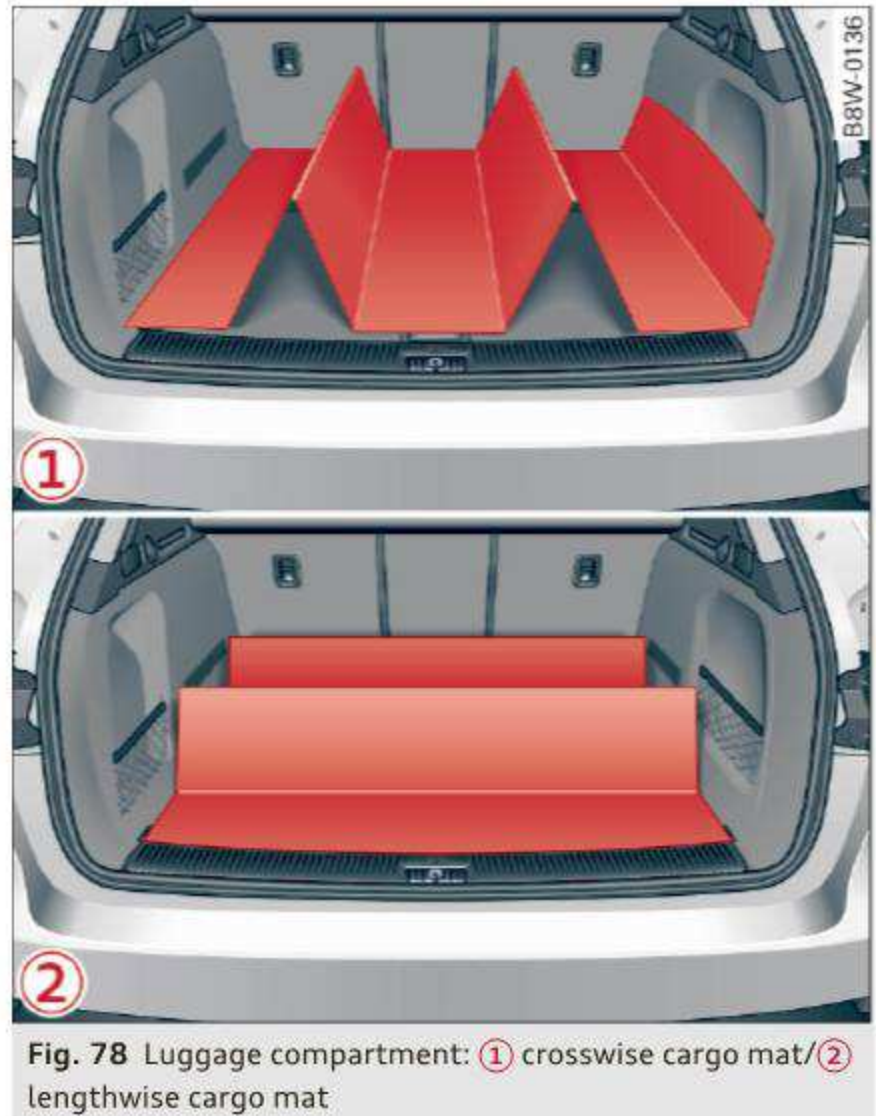

**Fig. 78** Luggage compartment: **1** crosswise cargo mat/**2** lengthwise cargo mat

The cargo mat is foldable and makes it possible to partition the loading surfaces into separate sections ⇒ *fig. 78*.

You can extend the cargo mat lengthwise when the backrest is folded up or down ⇒ *fig. 77*. If you extend it crosswise, you can also protect the side trim panels.

The cargo mat can be used on both sides. After loading or unloading, fold up the cargo mat and close the luggage compartment lid. Only store the cargo mat if it is dry.

You can save room by storing the cargo mat at the sides of the luggage compartment.

### Cargo floor

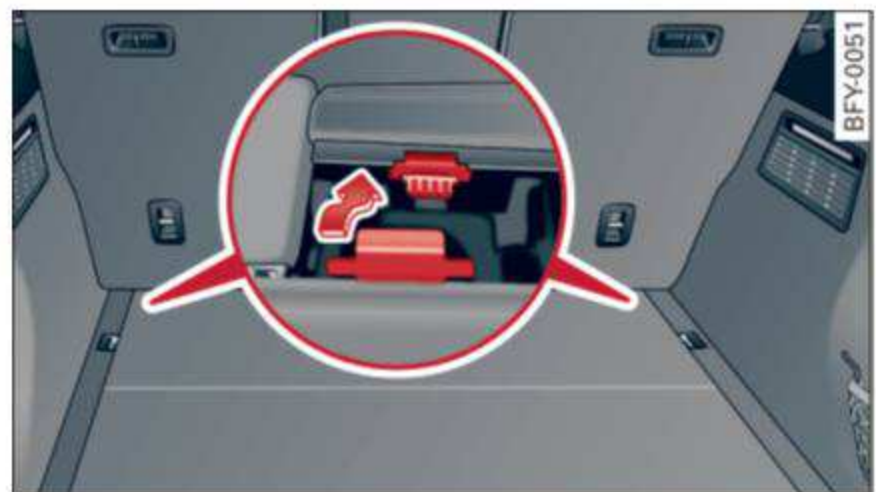

**Fig. 79** Luggage compartment: installing the cargo floor

### Removing and installing the cargo floor

- ▶ To remove the cargo floor, pull the entire cargo floor toward the back of the vehicle.
- ▶ To insert the cargo floor, slide it toward the backrests until it audibly engages into the tabs ⇒ *fig. 79*.

## Roof rack

Applies to: vehicles with roof rack

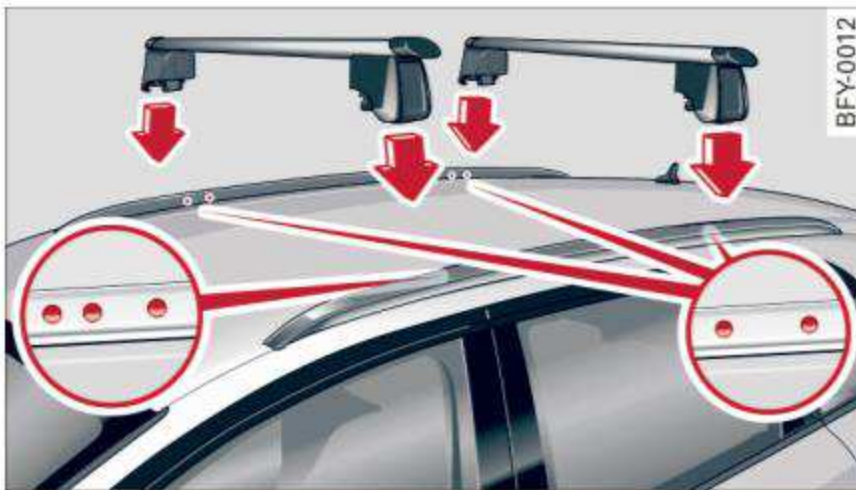

Fig. 80 Roof: mounting points for the roof rack

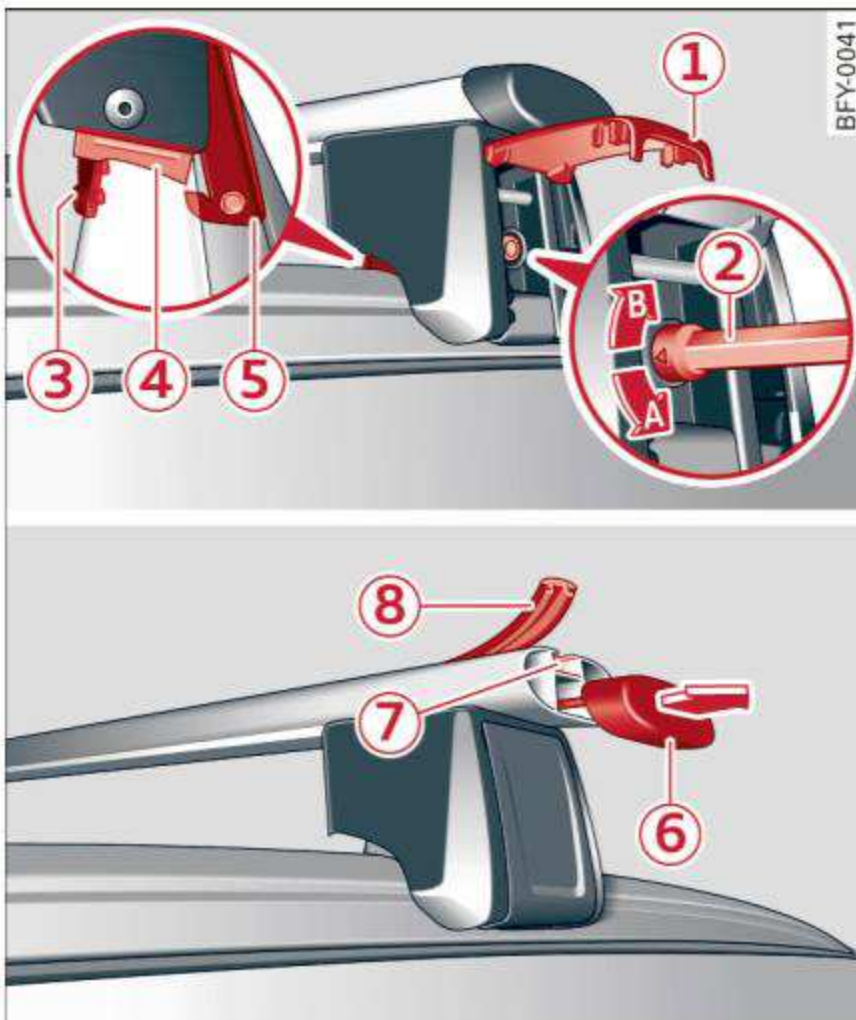

Fig. 81 Roof rail: installing a roof rack

If luggage or cargo is to be carried on the roof, you must observe the following:

- Only a specially designed roof rack may be used on your vehicle. These roof racks are the basis for a complete roof rack system. Additional attachments/carrier systems are necessary to transport luggage and sports equipment. We

recommend roof racks and attachments from the Audi Genuine Accessories program.

- Note the permitted axle load, permitted total weight, and permitted roof load of your vehicle ⇒ *page 370*. The roof load is the total of the weight of the roof rack, the attachments and the cargo you are carrying. However, you must also note the permitted load of the carrier system being used.

### Installing the roof rack

Applies to: vehicles with roof racks supplied by the factory

The roof rack set consists of a front and rear roof rack, the cover profile and a socket wrench. On the inner side of the roof rail, there are two holes for the rear roof rack. To prevent confusing the front and rear roof rack, there are three holes on the left inner side and two holes on the right inner side ⇒ *fig. 80*.

- Before mounting the roof rack, open the cap ① upward ⇒ *fig. 81*.
- Use the socket wrench ② to loosen the left and right screw in the direction of ③ until resistance is felt. Make sure the arrow on the socket wrench and the arrow on the screw line up exactly.
- Clean the rubber washers ④ and the roof rail around the mounting points.
- Carefully place the roof rack over the holes in the roof rail ⇒ *fig. 81*. Make sure the sticker is on the left side of the vehicle and the imprinted arrow points in the direction of travel.
- Place the pins ⑤ into the holes. The claw fastener ⑥ must engage into the edge of the roof rail. Make sure the rubber washers ④ lie flat on the roof rail.
- Tighten the screw in the direction of ⑦ using the socket wrench. Make sure the arrow on the socket wrench and the arrow on the screw line up exactly. The required tightening specification is 4 ft lbs (6 Nm).
- Repeat these steps for the other mounting points for the roof rack.

### Installing the attachments

Applies to: vehicles with roof racks supplied by the factory

- Remove the cap ⑧ to mount attachments on the roof rack. ⇒ *fig. 81*

## Seats and storage

- Slide the attachment into the T-groove ⑦.
- Tighten the attachment according to the roof rack installation instructions.
- Close the cap ⑥.

### Installing the cover profile

Applies to: vehicles with roof racks supplied by the factory

- After you have mounted the attachments, seal the openings in the T-groove ⑦ with the cover profile ⑧.
- If you do not want to use the attachment, seal the whole T-groove ⑦ with the cover profile ⑧.
- If necessary, cut the cover profile to the necessary length.

### WARNING

- Follow the installation instructions provided with the roof rack system. If you do not secure the roof rack system and objects on the roof correctly, they could come loose from the vehicle and cause an accident.
- The risk of an accident increases when using a roof rack system, because it changes the driving characteristics by shifting the center of gravity and/or the increasing the surface area exposed to wind. You may need to adapt your driving style and speed to the current conditions. We recommend that you do not drive faster than 80 mph (130 km/h).
- Distribute the cargo evenly on the roof rack and do not exceed the maximum width or the maximum total roof load weight.
- Before every trip, all bolts and connections on the roof rack must be checked. Tighten them if necessary and recheck them regularly. If you do not do this, there is a higher risk of the roof rack or the attachments loosening or falling off.

### Note

- If you use other roof luggage rack systems or do not install the roof racks as specified, then any damage to the vehicle is not covered by the warranty. Carefully follow the assembly and installation instructions included with the roof rack carrier system.

- To reduce the risk of damage, you must remove the roof rack and attachment before taking your vehicle through an automatic car wash.
- Make sure that the luggage compartment lid and the panorama glass roof\* do not come into contact with objects on the roof when they are open.

### For the sake of the environment

Your vehicle will use more fuel due to the increased wind resistance. So remove the roof rack after using it.

### Tips

Applies to: vehicles with roof racks supplied by the factory: when installing the roof rack supplied by the factory on the roof rail, sensor technology is used to adjust the ESC to any possible change in the vehicle's center of gravity resulting from the load.

## Warm and cold

### Climate control system

#### Description

The climate control system warms, cools and removes humidity from the air in the vehicle interior. It is the most effective when the windows and sunroof\* are closed. If there is a build-up of heat inside the vehicle, ventilation can help to speed up the cooling process.

In all heating mode functions except for *defrost*, the blower only switches to a higher speed once the engine coolant has reached a sufficient temperature.

#### Pollutant filter

The pollutant filter removes pollutants such as dust and pollen from the air.

#### Key recognition

The climate control settings are automatically stored and assigned to the remote control key that is in use.



#### For the sake of the environment

If you would like to reduce fuel consumption, switch the air conditioning off. This will also reduce emissions.



#### Tips

- To prevent interference with the heating and cooling output and to prevent the windows from fogging over, the air intake in front of the windshield must be free of ice, snow or leaves.
- Condensation from the cooling system can drip and form a puddle of water under the vehicle. This is normal and does not mean there is a leak.
- The energy management system may temporarily switch off certain functions, such as the seat heating\* or rear window defogger. These systems are available again as soon as the energy supply has been restored.

## 3 zone deluxe automatic climate control

### Operation

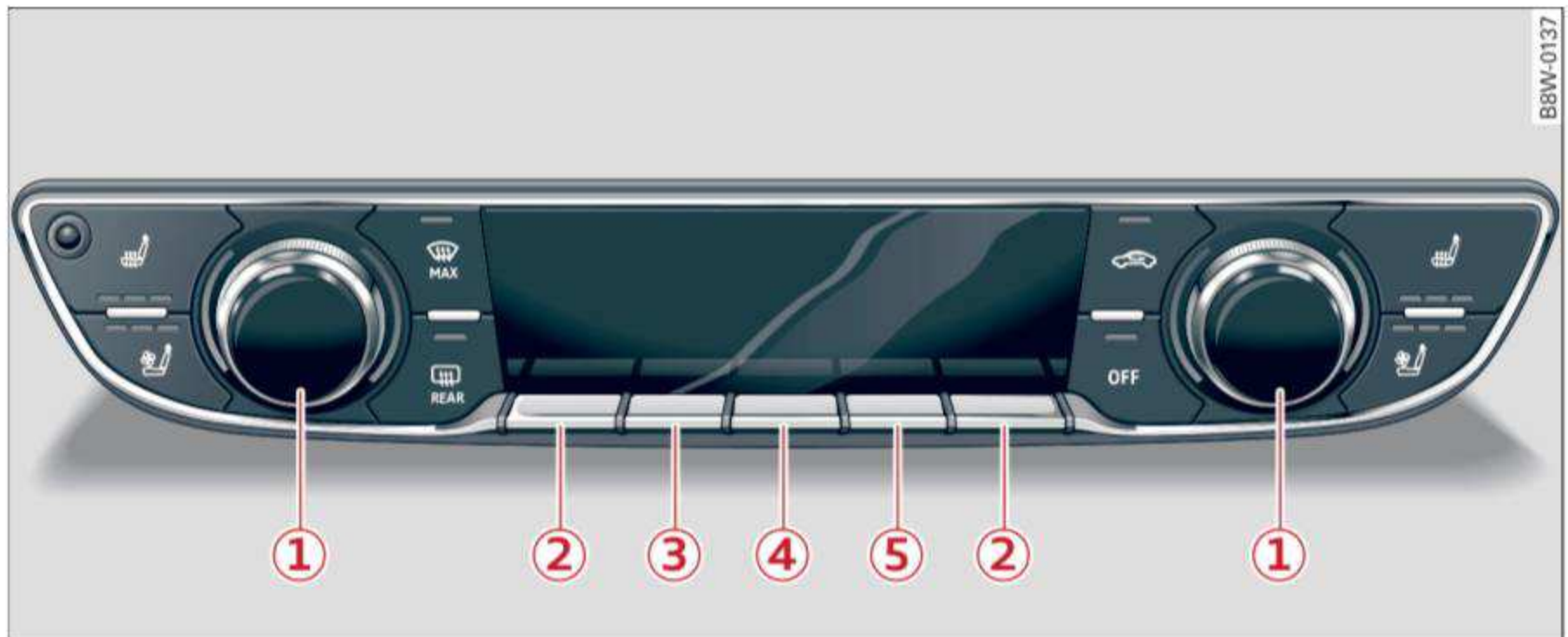

Fig. 82 3-zone deluxe automatic climate control: cockpit controls



Fig. 83 3-zone deluxe automatic climate control system: rear controls

Press the knobs, buttons or rocker switches to turn the functions on or off. When the function is switched on, the LED in the respective button or knob turns on ⇒ *fig. 82*. The rocker switches are sensitive to touch. The driver and front passenger settings can be adjusted separately.

You can adjust the settings for the rear of the vehicle using the controls in the rear ⇒ *fig. 83*.

On right-hand drive vehicles\*, the functions of the rocker switched ③ and ⑤ are switched.

#### OFF climate control system

The OFF button switches the climate control system on or off. It also switches on when you press

another button or a knob. Airflow from outside is blocked when the climate control system is switched off.

#### A/C Cooling mode

You can switch the cooling mode on or off using the rocker switch ③. The air is not cooled and humidity is not removed when cooling mode is switched off. This can cause fog on the windows. Cooling mode switches off automatically when the outside temperature is below zero.

#### A/C eco Cooling mode\*

You can switch the eco cooling mode on or off using the rocker switch ③. The climate control



system operates most efficiently in eco cooling mode.

### A/C MAX Cooling mode\*

You can switch the maximum cooling mode on or off using the rocker switch **③**. The air is not cooled and humidity is not removed when cooling mode is switched off. This can cause fog on the windows. Cooling mode switches off automatically when the outside temperature is below zero. When the cooling mode is switched on, the vehicle interior is cooled as quickly as possible and dehumidified.

### Recirculation mode

In recirculation mode, the air inside the vehicle is circulated and filtered. This prevents the unfiltered air outside the vehicle from entering the vehicle interior. Switching recirculation mode on when driving through a tunnel or when sitting in traffic is recommended ⇒ .

You can switch the recirculation mode on or off using the  button. You can also switch the recirculation mode off by pressing the knob **①** or the  button.

### AUTO automatic mode

Automatic mode maintains a constant temperature inside the vehicle. Air temperature, airflow and air distribution are controlled automatically. You can switch automatic mode on or off by pressing the knob **①**.

### Temperature

You can adjust the temperature between 60°F (+16°C) and 84°F (+28°C) by turning the knob **①**. If outside of this range, **LO** or **HI** will appear in the climate control system display. In both settings, the climate control runs constantly at the maximum cooling or heating level. The temperature is not regulated.

The temperature can be adjusted in the rear using the rear controls ⇒ *fig. 83*.

### Blower

You can adjust the volume of air generated by the blower to your preference using the rocker switch **④**. The blower should always run at a low setting

to prevent the windows from fogging and to ensure a continuous exchange of air inside the vehicle. To have the blower regulated automatically, press one of the knobs **①**.

### Air distribution

You can use the rocker switches **②** to adjust the vents where the air will flow out of. Press the rocker switches **②** repeatedly until the desired air distribution setting is displayed in the climate control system controls. To have the air distribution regulated automatically, press one of the knobs **①**.

### Seat heating/ventilation\*

Pressing the  button switches the seat heating/ventilation on at the highest setting (level 3). The LEDs indicate the temperature level. To reduce the temperature, press the button again. To switch the seat heating/ventilation off, press the button repeatedly until the LED turns off.

### Defrosting

The windshield and side windows are defrosted or cleared of condensation as quickly as possible. The maximum amount of air flows mainly from the vents below the windshield. Recirculation mode switches off. The temperature should be set at +72°F (+22°C) or higher. The temperature is controlled automatically.

You can switch the defroster on or off using the  button. You can switch the function off by pressing a knob **①**.

### REAR Rear window defogger

You can switch the rear window defogger on by pressing the  button. It only operates when the engine is running. It switches off automatically after 10 to 20 minutes, depending on the outside temperature.

To prevent the rear window defogger from switching off automatically, press and hold the  REAR button for more than three seconds. This is stored until the ignition is switched off. ►

### SYNC Synchronization

Use the rocker switch  to select the function. When synchronization is switched on, the settings for the driver's side are applied to the front passenger's side and the rear (except for seat heating/ventilation\*). When the settings on the front passenger's side or in the rear are changed, the synchronization is automatically switched off and **3-zone** appears in the display.

### SET REAR function

Use the rocker switch  to select the function. When the function is switched on, you can adjust all settings for the rear using the climate control system controls in the cockpit. The rear climate control system controls cannot be operated at the same time. This function switches off automatically after a certain period of time or after leaving the menu.

### Vents

You can open or close the center and rear vents in the cockpit and the vents in the rear center console using the ridged thumbwheels. The levers adjust the direction of the airflow from the vents.

### Residual heat

You can activate the residual heat function when the ignition is switched off by pressing the knob . The residual heat from the coolant is used to heat the vehicle interior. The residual heat function switches off automatically after about 15 minutes.

### WARNING

- You should not use the recirculation mode for an extended period of time, because no fresh air is drawn in and the windows can fog when cooling mode is switched off. This increases the risk of an accident.
- Individuals with reduced sensitivity to pain or temperature could develop burns when using the seat heating\* function. To reduce the risk of injury, these individuals should not use seat heating\*.

### Note

To avoid damaging the seat heating\* elements, do not kneel on the seats or place heavy pressure on one area of the seat.

### Setup

*The climate control system basic settings are accessed in the Infotainment system.*

- ▶ Select in the Infotainment system: **MENU** button > **Vehicle** > left control button > **Air conditioning**

### Auto recirculation

When switched on, automatic recirculation controls the recirculation mode automatically. If the windows fog up, press the  MAX button.



### Automatic auxiliary heater\*

The auxiliary heater helps to warm the vehicle interior more quickly.

## Steering wheel heating

Applies to: vehicles with steering wheel heating

*The steering wheel rim can be heated.*

- ▶ Press the   page 14, fig. 11 button on the multifunction steering wheel to switch the steering wheel heating on and off. The message **Steering wheel heating: on/Steering wheel heating: off** appears in the instrument cluster display.

The temperature is maintained at a constant level when steering wheel heating is switched on.

The steering wheel heating settings are stored automatically and assigned to the remote control key that is in use.

## Driving

### General information

#### Breaking in

A new vehicle must be broken in for the first 1,000 miles (1,500 km). Do not drive at speeds that will exceed 2/3 of the maximum permitted engine speed (RPM) for the first 600 miles (1,000 km), and avoid full acceleration during this period. You may gradually start increasing the RPM and the speed between 600 miles (1,000 km) and 1,000 miles (1,500 km).

During the first hours of use, the engine has a higher internal friction than later on when all moving parts have settled into place with each other.

How the vehicle is driven during the first 1,000 miles (1,500 km) also affects the engine quality. Drive at moderate engine speeds after the initial break-in period, particularly when running a cold engine. This will reduce engine wear and improve the mileage.

Do not drive at too low of an engine speed (RPM). Shift down if the engine stops running "smoothly". Extremely high engine speeds are automatically reduced.

#### Reducing the risk of vehicle damage

##### Note

When driving on poor roads, by curbs and on steep ramps, make sure that low-hanging components such as the spoiler and exhaust system do not come into contact with these or they could be damaged. This especially applies to vehicles with low ground clearance and vehicles that are heavily loaded.

#### Driving through water on roads

Note the following to reduce the risk of vehicle damage when driving through water, for example on flooded roads:

- The water must not be any higher than the bottom of the vehicle body.

- Do not drive faster than walking speed.

##### WARNING

After driving through water or mud, the effectiveness of the brakes may be reduced due to moisture on the brake rotors and brake pads. A few careful brake applications should dry off the brakes and restore the full braking effect.

##### Note

- Vehicle components such as the engine, transmission, suspension or electrical system can be severely damaged by driving through water.
- Always switch the Start/Stop system\* off when driving through water ⇒ *page 78*.

##### Tips

- Determine the depth before driving through water.
- Do not stop the vehicle, drive in reverse or switch the engine off when driving through water.
- Keep in mind that oncoming vehicles may create waves that raise the water level and make it too deep for your vehicle to drive through safely.
- Avoid driving through salt water, because this can cause corrosion.

#### Economical and environmentally-friendly driving

The amount of fuel consumption, the environmental impact and the wear to the engine, brakes and tires depends mostly on your driving style. With an anticipatory and economic driving style, fuel consumption can be reduced by approximately 10-15%. The following tips will help you conserve the environment and your money at the same time.

##### Anticipatory driving

A vehicle uses the most fuel when accelerating. When you drive with anticipation, you do not need to brake as often and so you accelerate less. When possible, let your vehicle coast with a gear ►

engaged, for example when you notice that the next traffic light is red. This produces an engine braking effect, which helps to protect the brakes and tires and reduces the emissions and fuel consumption to zero (fuel shut-off during deceleration).

### Shift efficiently

Upshifting earlier is an effective way to save fuel. Staying in a gear too long uses fuel unnecessarily.

Press down on the accelerator pedal slowly and avoid “kick-down”.

### Avoid full acceleration

You should rarely travel at the maximum vehicle speed. High speeds cause a disproportionately high increase in fuel consumption, emissions and traffic noise. Driving more slowly saves fuel.

### Reduce idling time

The Start/Stop system\* helps to reduce the idling time automatically. In vehicles without the Start/Stop system\*, it is efficient to switch the engine off when stopped at railroad crossings and long red lights. Stopping the engine for 30-40 seconds already saves more fuel than the amount of extra fuel needed to restart the engine.

It takes a very long time in idle to warm the engine up to operating temperature. Wear and emissions are especially high in the warm-up phase. Therefore, you should begin driving immediately after starting the engine. Avoid high RPMs while doing this.

### Have maintenance performed regularly

By having maintenance performed regularly on your vehicle, you can help to reduce fuel consumption before you even start to drive. The maintenance condition of your vehicle not only affects traffic safety and long-term value but also impacts fuel consumption. A poorly maintained engine can lead to fuel consumption that is 10% higher than normal.

### Avoid short trips

The engine and exhaust cleaning system must reach their optimal operating temperature to effectively reduce consumption and emissions.

A cold engine uses a disproportionately high amount of fuel. The engine reaches operating temperature and consumption normalizes only after approximately 2.5 miles (4 km).

### Check the tire pressure

To save fuel, make sure the tires are always inflated to the correct pressure ⇒ *page 335*. The fuel consumption can increase by 5% if the pressure is only 0.5 bar too low. Due to the increased rolling resistance, low tire pressures will also lead to greater tire wear and will affect driving behavior.

Do not drive on winter tires year-round, as this will consume up to 10% more fuel.

### Eliminate unnecessary weight

Since every pound of extra weight increases fuel consumption, a quick inspection of the luggage compartment may be worth it to avoid unnecessary weight.

When not being used, a roof rack should be removed to decrease the wind resistance of the vehicle. This will save you approximately 12% fuel at speeds from 62 - 75 mph (100 - 120 km/h).

### Save energy

The engine drives the generator, which generates electricity; the fuel consumption also increases with the demand for electricity. Therefore, switch electrical equipment off when you no longer need it. Examples of equipment that uses a lot of energy are air blowers at a high setting, the rear window defogger and seat heating\*.

#### Note

Do not leave engine idling unattended after starting. If warning lights should come on to indicate improper operation, they would go unheeded. Extended idling also produces heat, which could result in overheating or other damage to the vehicle or other property.

**Note**

- Have your vehicle maintained properly and in accordance with the service recommendations in your Warranty & Maintenance booklet. Lack of proper maintenance as well as improper use of the vehicle will impair the function of the emission control system and could lead to damage.
- Do not alter or remove any component of the Emission Control System unless approved by the manufacturer.
- Do not alter or remove any device, such as heat shields, switches, ignition wires, valves, which are designed to protect your vehicle's Emission Control System and other important vehicle components.

**Tips**

The consumption estimates as published by ENVIRONMENTAL PROTECTION AGENCY (EPA) and Transport Canada may not correspond to your actual consumption on the road, which will vary depending upon vehicle load and speed, road and weather conditions, trip length, etc.

## Steering

**Manual steering wheel position adjustment**

Applies to: vehicles with manual steering wheel adjustment

*The steering wheel position is adjustable up and down and forward and back.*



**Fig. 84** Steering column: lever for adjusting the steering wheel position

- ▶ Pull the lever in the direction of the arrow



- ▶ Bring the steering wheel into the desired position.
- ▶ Push the lever against the steering column until it is secure.

**WARNING**

Incorrect use of the steering wheel adjustment and an incorrect seating position can cause serious injuries.

- Only adjust the steering column when the vehicle is stationary so that you do not lose control of the vehicle.
- Adjust the driver's seat or steering wheel so that there is at least a 10 in (25 cm) distance between your chest and the steering wheel. If you do not maintain this distance, the airbag system will not be able to provide its full protection.
- If your physical characteristics prevent you from sitting at least 10 in (25 cm) or more away from the steering wheel, see if an authorized Audi dealer or authorized Audi Service Facility can provide adapters that will help.
- If your face is level with the steering wheel, the airbag does not provide as much protection during a collision. Always make sure that the steering wheel is level with your chest.
- Always hold the steering wheel with your hands in the 9 o'clock and 3 o'clock positions to reduce the risk of injury if the airbag deploys.
- Never hold the steering wheel in the 12 o'clock position or with both hands on the rim or the center of the steering wheel. Holding the steering wheel incorrectly significantly increases the risk of injury to the hands, arms and head if the driver airbag deploys.

### Power steering wheel position adjustment

Applies to: vehicles with power steering wheel adjustment

The steering wheel position can be adjusted electrically up and down and forward and back.

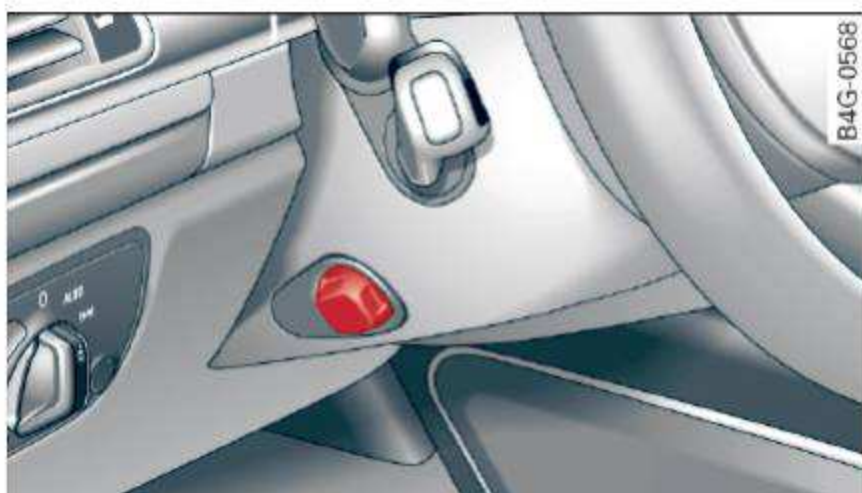

Fig. 85 Steering column: switch for adjusting the steering wheel position

- ▶ To adjust the height, press the switch up/down. The steering column will continue moving as long as you are pressing the switch.
- ▶ To move the steering wheel forward or back, press the switch forward/back. The steering column will continue moving as long as you are pressing the switch.

The steering wheel can also be adjusted when the ignition is switched off.

In vehicles with memory function\*, the steering column settings are stored together with the seat position.

### Easy seat entry

Applies to: vehicles with power steering wheel adjustment

Easy seat entry makes it easier to enter and exit the vehicle by adjusting the steering column automatically.

- ▶ Select in the Infotainment system: **MENU** button > **Vehicle** > left control button > **Vehicle settings** > **Seats** > **Driver's seat** > **Easy entry function**.

When easy seat entry is switched on, the steering column goes back up into the park position when the ignition is switched off. After entering the vehicle, the steering column returns to the stored position once the ignition is switched on.

## Starting and stopping the engine

### Starting the engine

The **START ENGINE STOP** button switches the ignition on and starts the engine.



Fig. 86 Cockpit: START ENGINE STOP button

### Starting the engine

- ▶ Press the brake pedal.
- ▶ Press the **START ENGINE STOP** button  
⇒ *fig. 86*. The engine will start.

### Switching the ignition on/off

If you would like to switch the ignition on without starting the engine, follow these steps:

- ▶ Press the **START ENGINE STOP** button without pressing the brake pedal. Vehicles without the Start/Stop system\*: the needle in the tachometer moves into the **READY** position.
- ▶ To switch the ignition off, press the button again. The needle in the tachometer moves into the **OFF** position.

Equipment that uses a lot of electricity is switched off temporarily when you start the engine.

If the engine does not start immediately, the starting procedure stops automatically after a short time. Repeat the starting procedure.

### Start/Stop system\*

See the information in ⇒ *page 78, Start/Stop system*.

### WARNING

To reduce the risk of poisoning, never allow the engine to run in confined spaces.

**Note**

Avoid high engine speed, full throttle, and heavy engine load if the engine has not reached operating temperature yet. You could damage the engine.

**For the sake of the environment**

Do not let the engine run while parked to warm up. Begin driving immediately. This reduces unnecessary emissions.

**Tips**

- Some noise after starting the engine is normal and is no cause for concern.
- If you leave the vehicle with the ignition switched on, the ignition will switch off after a certain amount of time. Make sure that electrical equipment such as the exterior lights are switched off.

**Starting the engine**

- ▶ Bring the vehicle to a full stop.
- ▶ Press the **START ENGINE STOP** button  
⇒ page 76, fig. 86.

**Emergency off function\***

If it is absolutely necessary, the engine can also be turned off while driving at speeds starting at 4 mph (7 km/h). To switch the engine off, press the **START ENGINE STOP** button twice in a row briefly or press and hold for longer than two seconds.

**WARNING**

- Never turn off the engine before the vehicle has come to a complete stop. The full functionality of the brake booster and the power steering is not guaranteed. You must use more force to steer and brake the vehicle. The fact that you cannot steer and brake as usual can increase the risk of accidents and serious injuries.
- If you leave the vehicle, switch the ignition off and take the vehicle key with you. If you do not, the engine could be started and electrical equipment such as the power win-

dows could be activated. This can lead to serious injuries.

- For safety reasons, always park the vehicle with the selector lever in the "P" position. Otherwise, there is the risk that the vehicle could roll unintentionally.

**Note**

If the engine has been under heavy load for an extended period of time, heat builds up in the engine compartment after the engine is switched off and there is a risk of damaging the engine. For this reason, let the engine run at idle for approximately two minutes before shutting it off.

**Tips**

For up to 10 minutes after stopping the engine, the radiator fan may turn on again automatically or it may continue to run (even if the ignition is switched off) for the following reasons:

- The coolant temperature is increasing due to trapped heat.
- If the engine is warm and the engine compartment also heats up from strong sunlight.

**Messages****Engine running. Warning! Turn off ignition before leaving vehicle**

This message appears and a warning tone sounds if you open the driver's door when the engine is running.

**Please press the brake pedal**

This message appears if you do not press the brake pedal when starting the engine.

**Remote control key: key not detected. Is the key still in the vehicle?**

This indicator light turns on and this message appears if the ignition key was removed from the vehicle when the engine was running. If the ignition key is no longer in the vehicle, you cannot switch on the ignition or start the engine once

you stop it. You also cannot lock the vehicle from the outside.

### Shift to P, otherwise vehicle can roll away. Doors do not lock if gearshift is not in P

This message appears for safety reasons if the selector lever is in the "N" position when you switch the ignition off. Move the selector lever to the "P" position. Otherwise the vehicle is not protected from rolling and it cannot be locked.

### Remote control key: hold back of key against the designated area. See owner's manual

If the indicator light turns on and this message appears, there is a malfunction ⇒ *page 78*.

### Shift to P before leaving vehicle, otherwise vehicle can roll away

This message appears if the driver's door is opened while the ignition is switched on and the transmission has not been shifted to the "P" position. Shift the transmission into the "P" position and turn off the ignition if you are leaving the vehicle. Otherwise the vehicle could roll. Also see ⇒ *page 79*.

### Starting the engine when there is a malfunction

*It may not be possible to start the engine under certain circumstances, for example, if the battery in the vehicle key is drained, if interference is affecting the key or if there is a system malfunction.*



**Fig. 87** Center console/remote control key: starting the engine if there is a malfunction

Requirement: the message **Remote control key: hold back of key against the designated area**.

**See owner's manual** must display and the  indicator light must turn on.

- ▶ Place the remote control key on the location shown in the illustration  ⇒ *fig. 87*.
- ▶ Press the brake pedal.
- ▶ Press the **START ENGINE STOP** button. The engine will start.
- ▶ Drive to an authorized Audi dealer or authorized Audi Service Facility immediately to have the malfunction corrected.

### Tips

You can view the message again by pressing the **START ENGINE STOP** button.

## Start/Stop system

### Description

Applies to: vehicles with Start/Stop system

The Start/Stop system can help increase fuel economy and reduce CO<sub>2</sub> emissions.

In Start/Stop mode, the engine shuts off automatically when stopped, for example at a traffic light. The ignition and important assist systems such as power steering and the brake booster will remain available during the "stop" phase. The engine will restart automatically when needed.

The Start/Stop system is automatically activated as soon as the ignition is switched on.

### Basic requirements

- The driver's door and hood must be closed.
- The "P", "N" or "D" selector lever position must be engaged.
- The steering wheel must not be sharply turned.
- The vehicle must have driven faster than 2 mph (3 km/h) since the last time it stopped.
- A trailer must not be hitched to the vehicle.

### Note

Always switch the Start/Stop system off when driving through water ⇒ *page 80*.

### Tips

- Depending on the driving situation, the engine may already stop when **coasting** before the vehicle has come to a complete stop <sup>1)</sup>.
- If you select the "D" selector lever position after shifting into reverse, the vehicle must be driven faster than 6 mph (10 km/h) in order for the Start/Stop system to be active again.

### Stopping/starting the engine

Applies to: vehicles with Start/Stop system

- ▶ Apply the brakes and keep your foot on the brake pedal until the vehicle has stopped. The  indicator light appears in the instrument cluster once the engine stops automatically.
- ▶ The engine starts again when you take your foot off the brake pedal. The indicator light turns off.

### Tips

- The ignition will turn off if you press the **START ENGINE STOP** button during a stop phase.
- You can determine for yourself if the engine will stop or not by reducing or increasing the amount of force you use to press the brake pedal. For example, if you only lightly press on the brake pedal in stop-and-go traffic or when turning, the engine will not switch off when the vehicle is stationary. As soon as you press the brake down harder, the engine will switch off.
- Press the brake pedal during a Stop phase to keep the vehicle from rolling.

### Starting/stopping the engine automatically

Applies to: vehicles with Start/Stop system

The system checks if certain conditions are met before and during the "stop" phase, and determines if and how long the engine is stopped depending on the situation. For example, if power usage is high, the engine will not be stopped.

Along with other conditions, the following factors influence the automatic engine start or stop:

- Environmental conditions (slopes, inclines, elevation, temperature)
- Battery (charge status, temperature, power usage)
- Engine temperature
- Assistance systems
- Driving behavior

If the  indicator light appears in the instrument cluster display, the engine will not be stopped.

### Switching the ignition off automatically

Applies to: vehicles with Start/Stop system

If you leave the vehicle during a "stop" phase, the engine can be restarted within approximately 30 seconds if the doors are closed, the driver's safety belt is fastened and the brake pedal is pressed.

If you leave the vehicle longer than 30 seconds, the ignition will switch off automatically to prevent the vehicle battery from draining. If this is the case, the message **Start/stop system: ignition will be switched off in 30s** will appear in the instrument cluster and, if the low beam headlights are switched on, the parking lights will switch on instead. The parking lights will switch off after approximately 30 minutes or when you lock the vehicle.

The ignition also switches off when you lock the vehicle from the outside during a stop phase.

If the Start/Stop system has not turned off the engine or if you have switched the Start/Stop system off manually, the ignition will not be automatically switched off and the engine will continue to run.



#### WARNING

To reduce the risk of poisoning, never allow the engine to run in confined spaces. ▶

<sup>1)</sup> Market-specific

**i Tips**

If you leave the vehicle with the "D/S" or "R" selector lever position engaged, the parking brake is automatically set.

**Manually switching the Start/Stop system off/on**

Applies to: vehicles with Start/Stop system

The (A) OFF button is located in the center console.

- ▶ Press (A) OFF to switch on or off. The LED in the button turns on when the function is switched off.

**i Tips**

If you switch the system off during a stop phase, the engine will start again automatically.

**Messages**

Applies to: vehicles with Start/Stop system

**Start/stop system: deactivated. Please start engine manually**

This message appears when specific conditions are not met during a stop phase. The Start/Stop system will not be able to restart the engine. The engine must be started with the **START ENGINE STOP** button.

**Start/stop system: malfunction! Function unavailable. Please contact Service**

There is a malfunction in the Start/Stop system. Drive the vehicle to an authorized Audi dealer or authorized Service Facility as soon as possible to have the malfunction corrected.

**Electromechanical parking brake**



Fig. 88 Center console: parking brake

Your vehicle is equipped with an electromechanical parking brake ① ⇒ fig. 88. The parking brake is designed to prevent the vehicle from rolling unintentionally and replaces the hand brake.

**Setting/manually releasing the parking brake**

- ▶ Pull the (P) switch to set the parking brake. The LED in the switch turns on. The **PARK** (USA models)/ (P) (Canada models) indicator light also turns on in the instrument cluster display.
- ▶ To release the parking brake manually, press the brake or accelerator pedal while the ignition is switched on and press the (P) switch at the same time. The LED in the button and the indicator light in the display turn off.

**Releasing the parking brake automatically**

Requirement: the doors must be closed and the driver's safety belt must be fastened.

- ▶ To start driving and release the parking brake automatically, press the accelerator pedal as usual.

In addition to releasing the parking brake automatically, other convenience and safety functions are available when you start driving ⇒ page 82, *Starting to drive*.

**Preventing the automatic parking brake release**

The vehicle could begin rolling unintentionally, depending on the hill or if towing a trailer. ▶

- ▶ To prevent the parking brake from releasing automatically, pull and hold the (P) switch and press the accelerator pedal. The parking brake remains set and prevents the vehicle from rolling backward.
- ▶ You can release the (P) switch again once you are sure that you are giving enough driving force to the wheels by pressing the accelerator pedal.

### Emergency braking function

You can use the emergency braking function in an emergency situation, or if the standard brake operation malfunctions or is disabled.

- ▶ Pull and hold the (P) switch.
- ▶ As soon as you release the (P) switch or accelerate, the braking stops.

Pulling and holding the (P) switch while driving the vehicle activates the emergency braking function. The vehicle is braked at all four wheels by activating the hydraulic brake system. The braking effect is similar to heavy braking ⇒ .

To reduce the risk of activating the emergency braking by mistake, a warning tone (buzzer) sounds when the (P) switch is pulled. Emergency braking stops as soon as the (P) switch is released or the accelerator pedal is pressed.

### Parking

- ▶ Press the brake pedal to stop the vehicle.
- ▶ Pull the (P) switch to set the parking brake.
- ▶ Select the "P" selector lever position.
- ▶ Turn the engine off ⇒ .
- ▶ Turn the steering wheel when parking on inclines so that the wheels will roll into the curb if the vehicle starts moving.

#### WARNING

- Do not press the accelerator pedal inadvertently if a gear is selected when the vehicle is stationary and the engine is running. Otherwise, the vehicle will start to move immediately and this could result in an accident.
- Emergency braking should only be used in an emergency, when the normal brake pedal has failed or the brake pedal is obstructed.

During emergency braking, your vehicle will brake similar to heavy braking. ESC and the associated components (ABS, ASR, EDL) cannot overcome the laws of physics.

Around curves and when road or weather conditions are bad, a full brake application can cause the vehicle to skid or the rear end to swerve, which increases the risk of an accident.

- If the power supply fails, you cannot set the parking brake if it is released. In this case, park the vehicle on level ground and secure it by placing the selector lever in the "P" position. See an authorized Audi dealer or authorized Audi Service Facility for assistance.
- Always set the parking brake when leaving your vehicle, even if for a short period of time. Otherwise the vehicle could roll away, increasing the risk of an accident.
- If you leave the vehicle, switch the ignition off and take the vehicle key with you. This applies particularly when children remain in the vehicle. Otherwise, children could start the engine, release the parking brake or operate electrical equipment such as power windows, which increases the risk of an accident.
- No one, especially children, should remain in the vehicle when it is locked. Locked doors make it more difficult for emergency workers to get into the vehicle, which puts lives at risk.

#### Tips

When stopping at a traffic signal or stopping in city traffic, you can set the parking brake manually. The vehicle does not have to be held with the brake pedal. The parking brake eliminates the tendency to creep when a selector lever position is engaged. As soon as you press the accelerator pedal, the parking brake releases automatically and your vehicle starts to move ⇒ *page 82*.

#### Tips

- Occasional noises when the parking brake is set and released are normal and are not a cause for concern.

- The parking brake goes through a self-test cycle at regular intervals when the vehicle is stopped. Any noises associated with this are normal.
- If there is a power failure, the parking brake will not set if it is released, and it will not release if it is set ⇒ ⚠. See an authorized Audi dealer or authorized Audi Service Facility for assistance.

## Starting to drive

Various convenience and safety functions may be available when the vehicle begins driving, depending on vehicle equipment.

### Starting on hills with the parking brake set

Requirement: the doors must be closed and the driver's safety belt must be fastened.

- ▶ To start driving comfortably when on a hill, set the parking brake and begin driving as usual. The braking force of the parking brake does not release automatically until the wheels build up enough driving force.

### Starting on hills with hill hold assist

Hill hold assist makes it easier to start on hills.

Requirement: the driver's door must be closed and the engine must be running.

- ▶ To activate hill hold assist, press and hold the brake pedal for several seconds. The vehicle must be in an uphill direction of travel.

After releasing the brake pedal, the braking power is maintained for a brief moment ⇒ ⚠ to prevent the vehicle from rolling back when starting. During this time, you can easily begin to move your vehicle.

#### WARNING

- If you do not begin driving immediately or the engine stalls after releasing the brake pedal, your vehicle may begin to roll backward. Press the brake pedal or set the parking brake immediately.
- The intelligent technology of hill hold assist cannot overcome the limitations imposed by

natural physical laws. The increased comfort offered by hill hold assist should not cause you to take safety risks.

- Hill hold assist cannot hold the vehicle in place on all hills (for example, if the ground is slippery or icy).
- To reduce the risk of an accident, always make sure the vehicle is situated safely while stationary.

## Offroad driving

### General information

The Electronic Stabilization Control (ESC) functions were enhanced for driving offroad. Offroad mode can be activated when driving in situations where slippage or a differential lock function is necessary ⇒ *page 141*. The hill descent assist is also available, which automatically brakes the vehicle to maintain a constant speed ⇒ *page 142*. In addition, your Audi provides continuous all wheel drive.

However, your Audi is not a purely offroad vehicle. Your vehicle was not designed to drive under extreme operating conditions such as driving in an expedition style.

**Only drive on terrain that is suitable for the vehicle and your driving ability. Never take any unnecessary risks!**

### Before driving offroad

- Check the engine oil level, the tire pressure, the coolant level and the fluid level in the washer fluid reservoir.
- Store pieces of luggage and other objects in the luggage compartment and secure them from sliding out of place.

### After driving offroad

- After driving offroad, remove branches and other debris from the radiator grille, underbody, and wheels. Look especially for foreign objects (such as stones) that may be stuck in the tire tread.
- Clean the vehicle body and underbody and inspect the vehicle for possible damage. ▶

- Clean the windows, headlights, tail lights and the license plate if they are dirty.
- Perform a brake test (especially after driving through water).

### WARNING

- Be especially cautious and aware when driving under difficult conditions and when off-road. Vehicle damage and injuries may occur when driving at excessively high speeds or with incorrect driving maneuvers.
- Always adjust your speed and driving style to the roads, terrain, traffic and weather conditions. Drive especially slowly if there is low visibility when offroad.
- Please note that the wheels can spin more and the vehicle can swerve when in offroad mode, especially when the road is slippery or has loose surface material.
- Driving stability is reduced when in offroad mode.

### For the sake of the environment

Avoid harming the environment and show consideration for nature.

### Tips

Only drive where it is permitted and always stay on the provided roads and paths.

### Explanation of technical terms

The following data is based on ideal conditions. The values may differ depending on the vehicle load, road characteristics, and the area. The driver is therefore responsible for deciding whether a vehicle can handle a specific situation ⇒ .

#### Pitch angle

The amount of vertical elevation change (grade) in a distances of 109 yards (100 meters) is specified as a percentage or in degrees. Specification of how steep of a grade the vehicle can drive up using its own power (depends on the road surface and the engine power, among other things). Maximum permitted pitch angle: 31°.

#### Ground clearance

The distance between the road surface and the lowest point of the vehicle underbody. Ground clearance: 8.1 in (205 mm)

### WARNING

- Exceeding the maximum specified values can lead to serious injuries or vehicle damage.
- All specifications were determined based on a level, firm, and non-slippery road surface in dry weather conditions.
  - The ideal conditions do not apply in offroad driving. Do not always go all the way up to the maximum values. Stay slightly below them for safety.

### Messages

*There is only one motto when driving in difficult conditions and offroad: drive slowly and with caution!*

Observe the following when driving on unpaved roads:

- ▶ Only drive in terrain that is suitable for the vehicle and your driving ability. Never take any unnecessary risks!
- ▶ Drive slowly and carefully.
- ▶ Pay attention to the **ground clearance** of your vehicle.
- ▶ Activate the **offroad mode** as needed ⇒ *page 141*.
- ▶ Use the **hill descent assist** when driving down steep hills ⇒ *page 142*.

#### Difficult terrain and off-road

When driving in unfamiliar areas and offroad, drive slowly and keep on the watch for unexpected obstacles (such as potholes, rocks, tree stumps, etc.).

To prevent the vehicle from bottoming out and to reduce the risk of underbody damage, you should drive across uneven ground on only one side of the vehicle so that only two of your wheels cross the uneven area, instead of driving across the center of the uneven area with all four wheels. ▶

## Driving

Drive quickly through sandy or marshy off-road sections and do not stop, if at all possible.

### Driving through water

Also read the information found in ⇒ page 73.

### Driving on a slope

If you are ever **unable** to drive up a hill, do not try to turn around. Drive back down in **reverse** instead. Otherwise you run the risk of tipping over.

**If the vehicle threatens to tip over when driving across a slope, you must immediately steer downhill in the direction of the slope.**

Do **not** park your vehicle on steep hills.

To reduce the risk of tipping over, drive on hills in the direction of the downward slope (fall line) - **never crosswise**.

## Tilt angle display

### Description

Applies to: vehicles with a tilt angle display



Fig. 89 Infotainment system: tilt angle display

You can see the vehicle position in relation to a level plane using the tilt angle display in the Infotainment system. Both the sideways angle (A) and the lengthwise angle (B) of the vehicle are displayed. The accuracy depends on the driving situation and is normally around 1°. The sideways angle of your vehicle should not exceed the yellow range in the gauge. If it reaches the red range, there is a risk that the vehicle might tip ⇒ ⚠.

### Displaying the tilt angle display

► Select in the Infotainment system: **MENU** button > **Vehicle** > **Lift / Offroad** or **Allroad\***.

### Showing the additional display

To change the contents shown in the right area of the screen, select in the Infotainment system: right control button > **Additional display**.

**Angle:** this displays the current steering wheel angle and the maximum angle that was reached during a drive. These values are reset when the ignition is switched off.

**Position:** displays the height, direction and geo-coordinates of the current vehicle position.

**Off:** only the air suspension display remains on.

### ⚠ WARNING

- Do not exceed the yellow range in the gauge. Your vehicle can tip, which increases the risk of an accident.
- Under some circumstances, the vehicle can tip over or tilt sideways even if the sideways angle is low. The angle display does not replace the driver's attention. To reduce the risk of an accident, make sure the vehicle does not tip, especially when you are driving at high speeds.

## Automatic transmission

### Introduction

The automatic transmission is controlled electronically. The transmission shifts up or down automatically depending on which drive program is selected.

When a **moderate driving style** is used, the transmission selects the most economical driving mode. The transmission upshifts at a lower RPM and downshifts at a higher RPM to improve fuel efficiency.

The transmission switches to a sporty mode after a kick-down or when the driver uses a **sporty driving style** characterized by quick accelerator pedal movements, heavy acceleration, frequent changes in speed and traveling at the maximum speed.

If desired, the driver can also select the gears **manually (tiptronic mode)** ⇒ page 88. ►

## S tronic transmission

The S tronic is a dual-clutch transmission. Power is transferred using two clutches that work independently from one another. They replace the torque converter used in conventional automatic transmissions and allow the vehicle to accelerate without a noticeable interruption in traction.

## tiptronic transmission

In the tiptronic transmission, power is transferred by a torque converter.

### Selecting a selector lever position

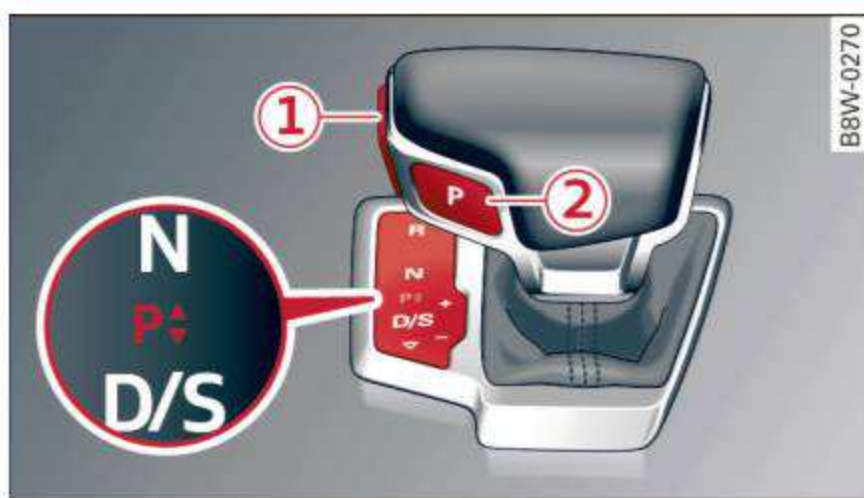

Fig. 90 Center console: selector lever

The current selector lever position is shown next to the selector lever ⇒ *fig. 90*. The current selector lever position is also shown in the instrument cluster display.

- ▶ You may need to release the selector lever lock depending on which selector lever position is selected and which one you would like to select.
- ▶ To do this, press the locking button ① on the selector lever ⇒ *fig. 90*.
- ▶ To engage the nearest selector lever position, move the selector lever forward/back until you feel the first pressure point. The selector lever will return to its original position.
- ▶ To skip over one selector lever position, move the selector lever past the pressure point into the desired position. The selector lever will return to its original position.

For example, you can skip over the "N" position if you would like to go directly from "D" into "R".

## Selector lever lock

The selector lever lock prevents you from selecting a position unintentionally, causing the vehicle to roll. When engaging some selector lever positions, you must press the locking button ① on the selector lever and/or press the brake pedal ⇒ *fig. 90*.

You must press the brake pedal to engage a selector lever position when the engine is running and the vehicle is stationary.

You do not have to press the brake pedal if you shift from "D" to "R" within one second. This allows you to "rock" the vehicle to free it when it is stuck.

## P - Park

This selector lever position prevents the vehicle from rolling. Only shift into park when the vehicle is stationary ⇒ ⚠. To select the "P" selector lever position, press the "P" button ② on the selector lever ⇒ *fig. 90*. **P** appears next to the selector lever.

Applies to vehicles with S tronic transmission: the parking lock can only be released when the ignition is switched on and the brake pedal is pressed. To release the parking lock, press the brake pedal, press the locking button ① on the selector lever and select the desired position ⇒ *fig. 90*. The engine must also be started in order to engage the "D" or "R" selector lever position.

Applies to vehicles with tiptronic transmission: the parking lock can only be released when the engine is running and the brake pedal is pressed. To release the parking lock, press the brake pedal, press the locking button ① on the selector lever and select the desired position ⇒ *fig. 90*.

"P" engages automatically if you switch the engine off while the selector lever is in "D", "E", "S", "R" or manual mode.

If you switch the engine off when the "N" selector lever position is selected, the transmission remains in "N" for approximately 30 minutes and then "P" is engaged. The vehicle is not secured ▶

from rolling in the "N" selector lever position, so you need to set the parking brake (P) ⇒ *page 80*.

You must use the parking lock emergency release before towing the vehicle ⇒ *page 90*.

### R – Reverse

The reverse gear is engaged in this position. Only select reverse gear when the vehicle is stationary and the engine is running at idle speed ⇒ ⚠. To engage the "R" selector lever position, press the brake pedal, press the locking button ① on the selector lever, and select the "R" position ⇒ *fig. 90*.

A confirmation tone will sound when the reverse gear is engaged.

### N - Neutral (idle)

The transmission is in idle in this position. To engage the "N" selector lever position, press the locking button ① on the selector lever and shift into the "N" position ⇒ *fig. 90*.

If you switch the engine off when the "N" selector lever position is selected, the transmission remains in "N" for approximately 30 minutes and then "P" is engaged.

You cannot select the "N" position when the ignition is switched off. When driving through an automatic car wash, first select the "N" position and then turn the engine off.

For safety reasons, the vehicle cannot be locked when the transmission is in the "N" position.

### D/S - Driving forward

When the transmission is in the "D/S" position, it can be operated either in the normal "D" mode or in the "S" sport mode. Move the selector lever back to engage the "S" sport mode. You can only select the "S" selector lever position when the "D" or "E" position is selected. To select the "D" or "E" position again when "S" is engaged, move the selector lever back ⇒ ⚠. To shift from "N" to "D" when traveling at speeds below 1 mph (2 km/h), press the brake pedal and shift into the "D" position ⇒ ⚠.

In the **normal mode** "D", the transmission automatically selects the suitable gear ratio. It de-

pends on engine load, vehicle speed and driving style.

Select the **sport mode** "S" for sporty driving. The vehicle makes full use of the engine's power. Shifting may become noticeable when accelerating.

The "S" selector lever position engages automatically when you select the dynamic\* mode in **drive select**.

### ⚠ WARNING

Read and follow all WARNINGS.

- The vehicle can roll even if the ignition is switched off.
- Power is still transmitted to the wheels when the engine is running at idle. To prevent the vehicle from "creeping", you must keep your foot on the brake in all selector lever positions (except "P" and "N") when the engine is running.
- Before opening the hood, select the "P" selector lever position and set the parking brake. This reduces the risk of an accident. Always read and follow the applicable warnings ⇒ *page 314, Working in the engine compartment*.

### i Tips

If you accidentally select "N" while driving, take your foot off the accelerator pedal and wait for the engine to slow down to idle before selecting "D" or "S".

## Driving tips

### Starting the engine

- ▶ The "P" or "N" position must be selected.

### Starting from a stop

- ▶ Press and hold the brake pedal.
- ▶ Start the engine ⇒ *page 76*.
- ▶ Press the locking button ① on the selector lever and select the "D", "E", "S" or "R" position ⇒ *page 85*.
- ▶ Wait a moment until the transmission shifts. You will notice a slight movement when the gear engages.

- ▶ Release the brake pedal and press the accelerator pedal ⇒ .



Various convenience functions are available for starting on hills ⇒ *page 82*.

### Stopping temporarily

- ▶ Press the brake pedal to stop the vehicle, for example at a traffic light. Do not press the accelerator pedal when doing this.
- ▶ To prevent the vehicle from rolling when you start driving, set the parking brake when stopping on steep hills ⇒ .
- ▶ The parking brake will release automatically and your vehicle will begin to move when the doors are closed, the driver's safety belt is fastened, and you accelerate as usual.

### Stopping/parking

If the selector lever is not in the "P" position when you open the driver's door, the vehicle could roll.

- ▶ Press and hold the brake pedal ⇒ .
- ▶ Set the parking brake.
- ▶ To select the "P" selector lever position, press the "P" button  on the selector lever ⇒ *page 85, fig. 90*.

Under certain conditions, such as driving in the mountains or when towing a trailer, it may be helpful to switch to manual mode temporarily and shift *manually* to adapt to the driving conditions ⇒ *page 88*.

On hills, set the parking brake first and then shift into the "P" position ⇒ *page 80*. This prevents too much stress from being placed on the locking mechanism.

#### WARNING

- The vehicle can roll even when the engine is switched off.
- Unintended vehicle movement can lead to serious injuries.
- To reduce the risk of an accident, do not press the accelerator pedal when changing the selector lever position while the vehicle is stationary and the engine is running.

- To reduce the risk of an accident, never select the "R" or "P" positions while driving.
- Do not inadvertently press the accelerator pedal when the vehicle is stationary. Otherwise the risk of an accident increases because the vehicle will start to move immediately, even if the parking brake is set.

### Hill descent control

*The hill descent control system assists the driver when driving down hills.*

Hill descent control activates when the transmission is in the "D" or "S" position and you press the brake pedal. The transmission automatically selects a gear that is suitable for the hill. Hill descent control tries to maintain the speed achieved at the time of braking, within physical and technical limitations. It may still be necessary to adjust the speed with the brake pedal.

Hill descent control switches off once the hill levels out or you press the accelerator pedal.

When operating the cruise control system\* ⇒ *page 95*, hill descent control is also activated when the speed is set.

#### WARNING

Hill descent control cannot overcome physical limitations, so it may not be able to maintain a constant speed under all conditions. Always be ready to apply the brakes.

### Shifting manually (tiptronic mode)

The tiptronic mode allows the driver to shift the gears manually.



Fig. 91 Center console: shifting manually with the selector lever



Fig. 92 Steering wheel: shifting manually

### Shifting with the selector lever

You can shift into tiptronic mode while stationary and while driving.

- ▶ To shift into tiptronic mode, push the selector lever from the "D/S" position to the right. As soon as the transmission switches over, the "M" transmission setting will appear in the instrument cluster display.
- ▶ To shift up a gear, tap the selector lever forward **+** ⇒ fig. 91.
- ▶ To shift down a gear, tap the selector lever backward **-**.
- ▶ To switch tiptronic mode off, push the selector lever back into the "D/S" position.

### Shifting with the shift paddles

You can operate the shift paddles in the "D/S" or "M" selector lever positions.

- ▶ To shift up a gear, tap the shift paddle **+** ⇒ fig. 92.
- ▶ To shift down a gear, tap the **-** shift paddle.

- ▶ To engage the lowest gear, hold the **-** shift paddle.
- ▶ If you do not press a shift button within a short time while in the "D/S" position, the transmission will return to automatic mode. To keep shifting using the shift paddles, move the selector lever to the right out of the "D/S" position.
- ▶ When you want to shift out of tiptronic mode, press and hold the **+** shift paddle for a longer period of time or move the selector lever back and release it.

The transmission automatically shifts up or down before critical engine speed is reached.

The transmission only allows manual shifting when the engine speed is within the permitted range.

#### **i** Tips

- If you shift to the next lowest gear, the transmission will only shift if the engine will not be over-revved.
- With kick-down, the transmission shifts to a lower gear, depending on vehicle speed and engine speed.
- tiptronic does not work if the transmission is running in emergency mode.

### Kick-down

*Kick-down enables maximum acceleration.*

When you press the accelerator pedal down beyond the resistance point, the automatic transmission downshifts into a lower gear and the engine utilizes its full power, depending on vehicle speed and engine RPM. It shifts up into the next higher gear once the maximum specified engine RPM is reached.

#### **!** WARNING





Please note that the wheels could spin on slick or slippery roads when kick-down is active.

## Launch control program

Applies to: vehicles with S tronic transmission

*The launch control program provides the best possible acceleration when starting from a stop.*

Requirement: the engine must be at operating temperature and the steering wheel must not be turned.

- ▶ Deactivate the Start/Stop system\* ⇒ *page 80*. The LED in the  button turns on.
- ▶ With the engine running, press the  button briefly ⇒ *page 141*. The  indicator light turns on and the message **Stabilization control (ESC): offroad. Warning! Reduced stability** appears in the instrument cluster display.
- ▶ Pull the selector lever back out of the "D/S" position briefly to select the "S" position or select the **Dynamic** driving mode in drive select\* ⇒ *page 127*.
- ▶ Press the brake pedal firmly with your left foot and hold it all the way down for at least one second.
- ▶ At the same time, press the gas pedal all the way down with your right foot until the engine reaches and stays at a high RPM level.
- ▶ Remove your foot from the brake pedal within five seconds ⇒ .

### WARNING

- Always adapt your driving to the traffic flow.
- Only use the Launch control program when road and traffic conditions allow it and other drivers will not be endangered or bothered by your driving and the vehicle's acceleration.
- Please note that the drive wheels can spin and the vehicle can break away when off-road mode is switched on, especially when the road is slippery.
- Once the vehicle has started moving, press the  button briefly to turn the offroad mode off.

### Tips

- The transmission temperature may increase significantly after using the launch control program. If that happens, the program may

not be available for a few minutes. It will be available again after a cool-down period.

- When accelerating using the launch control program, all vehicle parts are subject to heavy loads. This can lead to increased wear.

## Transmission malfunction

### Transmission: too hot. Please stop vehicle

Do not continue driving. Select the "P" selector lever position and contact an authorized Audi dealer or authorized Audi Service Facility for assistance.

### Transmission: malfunction! Please stop vehicle and shift to P

Do not continue driving. Select the "P" selector lever position and contact an authorized Audi dealer or authorized Audi Service Facility for assistance.

### Selector lever: malfunction! You can continue driving. Please contact Service

There is a system malfunction in the transmission. Drive to an authorized Audi dealer or authorized Audi Service Facility immediately to have the malfunction corrected.

### P button: malfunction! Auto P when engine off. Please contact Service

There is a malfunction in the "P" button on the selector lever. The transmission automatically engages "P" when you switch off the engine. Drive to an authorized Audi dealer or authorized Audi Service Facility immediately to have the malfunction corrected.

### Selector lever: malfunction! Gear change only possible using both paddle levers. Please contact Service

There is a system malfunction in the transmission. You can continue driving with restricted function. The selector lever is not working. Gears can only be selected by tapping both shift paddles at the same time when the vehicle is stationary ⇒ *page 88, fig. 92*. Pay attention to the selected transmission position in the instrument

cluster display. The parking lock engages automatically when you turn off the engine. Drive to an authorized Audi dealer or authorized Audi Service Facility immediately to have the malfunction corrected.

### **⚠️ Transmission: Please press brake pedal and select gear again**

Press the brake pedal and select the desired selector lever position again. You can then continue driving.

### **⚠️ Transmission: too hot. Please adapt driving style**

The transmission temperature has increased significantly. Drive very cautiously or take a break from driving until the temperature returns to the normal range and the indicator light turns off.

### **⚠️ Transmission: malfunction! You can continue driving. See owner's manual**

There is a system malfunction in the transmission. You may continue driving. Drive to an authorized Audi dealer or authorized Audi Service Facility soon to have the malfunction corrected.

### **⚠️ Transmission: malfunction! You can continue driving in D until engine is off**

There is a system malfunction in the transmission. The transmission is switching to emergency mode. If you turn the engine off, you will not be able to select any other selector lever positions after starting the engine again. Drive to an authorized Audi dealer or authorized Audi Service Facility immediately to have the malfunction corrected.

### **⚠️ Transmission: malfunction! You can continue driving with limited function. Please contact Service**

There is a system malfunction in the transmission. The transmission is switching to emergency mode. This mode only shifts into certain gears or will no longer shift at all. The engine may stall. Drive to an authorized Audi dealer or authorized Audi Service Facility immediately to have the malfunction corrected.

### **⚠️ Transmission: malfunction! You can continue driving with limited function. No reverse gear**

There is a system malfunction in the transmission. The transmission is switching to emergency mode. This mode only shifts into certain gears or will no longer shift at all. The engine may stall. You cannot engage the reverse gear. Drive to an authorized Audi dealer or authorized Audi Service Facility immediately to have the malfunction corrected.

### **⚠️ Danger of rolling away! P not possible. Please apply parking brake**

- The parking lock was released using the emergency release ⇒ *page 90*. Or
- The parking lock can no longer be engaged. Drive to an authorized Audi dealer or authorized Audi Service Facility immediately to have the malfunction corrected.

### **⚠️ Move selector lever to automatic position**

There is a malfunction in the tiptronic mode. End tiptronic mode by pushing the selector lever to the left into the "D/S" position.

## Parking lock emergency release

*The parking lock must be released with the emergency release when driving through mountains/maneuvering.*



**Fig. 93** Driver's side footwell: releasing the parking lock using the emergency release

The emergency release is located under the floor mat on the driver's side. ▶

### Releasing the parking lock using the emergency release

- ▶ To prevent the vehicle from rolling unintentionally, set the parking brake (P) ⇒ *page 80* or press the brake pedal.
- ▶ There are two slits on the cover. Position the screwdriver from the vehicle tool kit in one of the slits on the cover and pry the cover off.
- ▶ Insert the socket wrench (from the vehicle tool kit) into the opening ⇒ *fig. 93*.
- ▶ Turn the socket wrench all the way clockwise ① and press it downward ② until it locks into place.
- ▶ Leave the socket wrench inserted ⇒ ⚠.

### Resetting the parking lock

- ▶ Press the brake pedal and start the engine.
- ▶ Keep the brake pedal pressed and engage the following selector lever positions one after the other: "N", "D" and back to "N".
- ▶ Turn the engine off again.
- ▶ Grasp the socket wrench with both hands and pull it up and out carefully to remove ⇒ ⚠.
- ▶ Install the cover.

When the parking lock emergency release is used, the ⚠ indicator light and the "N" selector lever position turn on in the instrument cluster. The message **Danger of rolling away! P not possible. Please apply parking brake** also appears.

#### WARNING

- Only activate the emergency release while on a level surface or a slight slope.
- The parking lock may only be released using the emergency release if the parking brake is set. If it is not functioning, secure the vehicle from rolling using the brake pedal or other suitable means, such as blocking a front and a rear wheel. An unsecured vehicle may roll away, which increases the risk of an accident.
- To reduce the risk of an accident, you must not drive when the emergency release is activated.

#### Note

- Read and follow the important instructions about towing ⇒ *page 365*.
- The risk of damage increases if you do not remove the socket wrench carefully when resetting the parking lock.

# Trailer towing

## Driving with a trailer

### General information

Your vehicle is primarily intended for transporting people and luggage. However, if you drive with a trailer, follow the technical requirements, the operation and driving tips, and the legal regulations.

Driving with a trailer affects the vehicle's fuel consumption, performance and wear. It also requires higher concentration from the driver.

### WARNING

Do not transport any people in a trailer due to the risk of fatal injury.

### Technical requirements

*Certain requirements must be met when towing a trailer.*

#### Trailer hitch

Only use a trailer hitch with a removable ball hitch mount and ball hitch. The trailer hitch must be permitted for the vehicle, the trailer and the permitted total weight of the trailer being pulled. Above all, it must be securely and safely attached to the vehicle trailer.

Never mount a trailer hitch on the bumper. The trailer hitch must be mounted in a way that does not impair the function of the bumper. Do not make any changes to the exhaust system and the brake system.

Check regularly if the trailer hitch is securely mounted. Always follow the instructions given by the trailer hitch manufacturer.

#### Trailer brakes

If the trailer has its own brake system, then follow the manufacturer specifications. However, the brake system on the trailer must never be connected to the vehicle brake system.

#### Engine cooling system

Driving with a trailer means a higher load on the engine and the cooling system. The cooling system must be designed for additional load and contain enough coolant ⇒ .

### WARNING

- Never mount a "weight-distributing" or "load-balancing" trailer coupler as the trailer hitch. The vehicle was not designed for these types of trailer hitches. The trailer hitch can malfunction and the trailer can break off from the vehicle.
- If the trailer is equipped with electronic brakes, these brakes cannot be activated by a factory-installed control system, which increases the risk of an accident.
- To reduce the risk of injury, always remove the ball hitch mount if no trailer is mounted.

### Note

Longer inclines cannot be driven without a suitable cooling system, especially if the outside temperatures are high. otherwise, this increases the risk of engine damage.

### Operating instructions

*Several things must be noted when towing a trailer.*

#### Towing capacity

The permitted towing capacity must not be exceeded under any circumstances ⇒ *page 370*.

You can drive up larger inclines if you are not using the maximum towing capacity.

The towing capacities given only apply to elevations up to 3,200 ft (1,000 m) above sea level. As the elevation increases, the engine power decreases due to the decreasing air pressures. This reduces the hill climbing ability and towing capacity. For every additional 3,200 ft (1,000 m), the maximum permitted towing weight must be reduced by approximately 10%. The permitted towing weight is the combined weight of the (loaded) vehicle and the (loaded) trailer. ►

## Tongue weight

The maximum permitted tongue weight of the trailer drawbar on the trailer hitch ball head may not be exceeded.

If the tongue weight is too low, this affects the trailer's handling. For driving safety, we recommend to always utilize the maximum permitted tongue weight, but not exceed it. You can reach it, for example, by distributing the cargo in the trailer correctly.

You can determine the tongue weight, for example, with a bathroom scale or a public weigh station.

The permitted tongue weight of your vehicle can be found in the vehicle documentation or in ⇒ *page 370*.

## Load distribution

Poor cargo load and distribution can negatively impact vehicle handling.

- Store objects preferably in the vehicle luggage compartment. The vehicle should always carry the heaviest possible load and the trailer should have the lightest possible load.
- Distribute the load in the trailer so that the heavy objects are as close to the axle as possible.
- Secure objects from sliding out of place.
- Utilize the maximum permitted tongue weight if possible.

## Tires

Set the tire pressure on your vehicle for a “full load”; see the tire pressure sticker ⇒ *page 335*. If necessary, also adjust the tire pressure on the trailer according to the manufacturer's recommendation.

Winter tires should be mounted on the vehicle and on the trailer during winter temperatures.

## Outside mirrors

If you cannot see the traffic behind the trailer with the standard exterior mirrors, then you must attach additional exterior mirrors. Adjust them so you have a sufficient visibility behind you.

## Exterior lighting

Follow the legal regulations regarding the lighting equipment on your trailer. Contact an authorized Audi dealer or authorized Audi Service Facility for more information.

Before starting to drive, check all lighting equipment on the hitched trailer.

The headlight range control adjusts automatically to the light range of the headlights.

## Safety chains

Make sure the safety chains are correctly applied when pulling a trailer. The chains should hang enough so that the trailer can drive around curves. However, they must not touch the ground.

## Air suspension

Applies to: vehicles with air suspension

The air suspension must be at the standard vehicle height before you set the tongue weight on the trailer and hitch the trailer ⇒ , ⇒ *page 128, Raising/lowering the vehicle*.

For vehicles with a factory-installed trailer hitch, the air suspension trailer mode will automatically switch on if you connect the trailer cable to the socket.

For vehicles with a retrofitted trailer hitch, you must switch on the air suspension trailer mode manually. Select in the Infotainment system: **MENU** button > **Vehicle** > left control button > **Vehicle settings** > **Air suspension: trailer**. Switch it off again after towing a trailer.

You can also switch off trailer mode manually while driving, for example, when using a bicycle rack system.

If you have to drive through difficult road conditions, you can raise the vehicle again after hitching the trailer or after adjusting the tongue weight.

### Note

Applies to: vehicles with air suspension

- Changes in temperature or load can affect the height of the vehicle.

## Trailer towing

- Set the air suspension to the standard vehicle height, otherwise the applicable tongue weight no longer applies to your vehicle.

### Tips

- Use chocks when parking on inclines if the trailer is loaded.
- We recommend also having the vehicle inspected between the inspection intervals if you are towing a trailer frequently.
- Avoid driving with a trailer during the vehicle break-in period.

## Driving with a trailer

*Driving with a trailer requires extra caution.*

### Speed

Adhere to the legal speed limits. Follow the legal regulations specific to the country.

As the speed increases, the driving stability of the trailer decreases. Therefore you should not exceed the maximum legal speed limit when there are unfavorable road, weather and/or wind conditions. This especially applies when driving downhill.

You must always reduce your speed as soon as you notice even the slightest swinging motion of the trailer. Never try to “straighten out” the trailer by accelerating.

The weight distribution is very poor if the vehicle is empty and the trailer is loaded. However if you must drive under these circumstances, then drive especially slowly.

### Brakes

Brake in a timely manner. Downshift before driving downhill so that the engine can assist with braking ⇒ .

When using a trailer with overrun brakes, first brake gently then quickly. This reduces the risk of jerking while braking if the trailer wheels lock up.

### Engine coolant temperature

Pay attention specifically to the coolant temperature display when there are high outside temperatures, and when driving on long inclines

⇒ *page 11*. Shift to a higher gear in a timely manner.



### WARNING

Constant braking causes the brakes to overheat and substantially reduces braking performance, increases braking distance or causes complete failure of the brake system.





## Assistance systems

### Speed warning system

#### Description

Applies to: vehicles with speed warning system

The speed warning system helps you to stay below a specified maximum speed that can be set, changed or deleted in the Infotainment system.

The speed warning system warns you if you are exceeding the maximum speed that you have set. A warning tone will sound as soon as your speed exceeds the stored value slightly. The  (USA models) /  (Canada models) indicator light and a message appear in the instrument cluster display at the same time. The  /  indicator light and the message turn off if the speed falls back below the stored maximum speed.

Setting a threshold is recommended if you would like to be reminded when you reach a certain maximum speed. Situations where you may want to do so include driving in a country with a general speed limit or if there is a specified maximum speed for winter tires.

#### Setting the warning threshold

Select in the Infotainment system: **MENU** button > **Vehicle** > left control button > **Driver assistance** > **Speed warning** > **Manual**.

#### Tips

Regardless of the speed warning system, you should always monitor your speed using the speedometer and make sure you are following the legal speed limit.

### Cruise control system

#### Switching on

Applies to: vehicles with cruise control system

The cruise control system makes it possible to drive at a constant speed starting at 15 mph (20 km/h).



Fig. 94 Operating lever: cruise control system

- ▶ To switch the system on, pull the lever into position ① ⇒ fig. 94.
- ▶ Drive at the speed to be maintained.
- ▶ To store the speed, press the button A.

The stored speed and the **CRUISE** (USA models) /  (Canada models) indicator light appear in the instrument cluster display. An additional indicator appears in the head-up display\*.

The speed is maintained by modifying engine power or through an active brake intervention.

#### WARNING

- Always pay attention to the traffic around you when the cruise control system is in operation. You are always responsible for your speed and the distance between your vehicle and other vehicles.
- For safety reasons, cruise control should not be used in the city, in stop-and-go traffic, on winding roads and when road conditions are poor (such as ice, fog, gravel, heavy rain and hydroplaning), because this increases the risk of an accident.
- Switch the cruise control off temporarily when driving in turning lanes, highway exits or in construction zones.
- Please note that unconsciously “resting” your foot on the accelerator pedal prevents

the cruise control from braking. This is because pressing the accelerator pedal overrides the cruise control system.

- If a brake system malfunction such as overheating occurs when the cruise control system is switched on, the braking function in the system may be switched off. The rest of the cruise control system functions remain active as long as the **CRUISE** (USA models) /  (Canada models) indicator light is on.

### Note







Before driving downhill a long distance on a steep hill, decrease your speed and select a lower gear. This makes use of the engine braking effect and relieves the brakes.

### Tips

The brake lights turn on when the brakes are applied automatically.

## Changing the speed

Applies to: vehicles with cruise control system

- ▶ To increase/decrease the speed in 1 mph (1 km/h) increments, briefly **tap** the lever toward / ⇒ *page 95, fig. 94* to the first level.
- ▶ To increase/decrease the speed in 5 mph (10 km/h) increments, briefly **tap** the lever toward / to the second level.
- ▶ To increase or decrease the speed quickly, **hold** the lever toward / to the first or second level until the desired speed is reached.

## Overriding the speed

Applies to: vehicles with cruise control system



You can press the accelerator pedal to increase your speed, for example if you want to pass someone. The speed you set earlier will resume as soon as you release the accelerator pedal.

However, if you are exceeding the stored speed by a considerable amount for a long time, the cruise control system will temporarily switch off. The **CRUISE** (USA models) /  (Canada models) indicator light in the instrument cluster turns off and the stored speed is maintained.

## Preselecting a speed

Applies to: vehicles with cruise control system

*You can pre-select your desired speed when the vehicle is stationary.*

- ▶ Switch the ignition on.
- ▶ Pull the lever into position  ⇒ *page 95, fig. 94*.
- ▶ To increase or decrease the speed, tap the lever toward /.

This function makes it possible, for example, to save the speed you want before driving on the highway. Once you are on the expressway, activate the cruise control system by pulling the lever into position .

## Switching off

Applies to: vehicles with cruise control system

### Deactivating temporarily

- ▶ Press the brake pedal, or
- ▶ Press the lever toward  (not locked into place) ⇒ *page 95, fig. 94*.

### Switching off completely

- ▶ Press the lever into position  (clicked into place), or
- ▶ Switch the ignition off.

The speed you stored will be maintained if the cruise control has been switched off temporarily. To resume the stored speed, release the brake pedal and pull the lever to position .

Switching the ignition off will erase the stored speed.



### WARNING

You should only resume the stored speed if it is not too high for existing traffic conditions. Otherwise you can increase the risk of an accident.

## Camera-based traffic sign recognition

### Description

Applies to: vehicles with camera-based traffic sign recognition

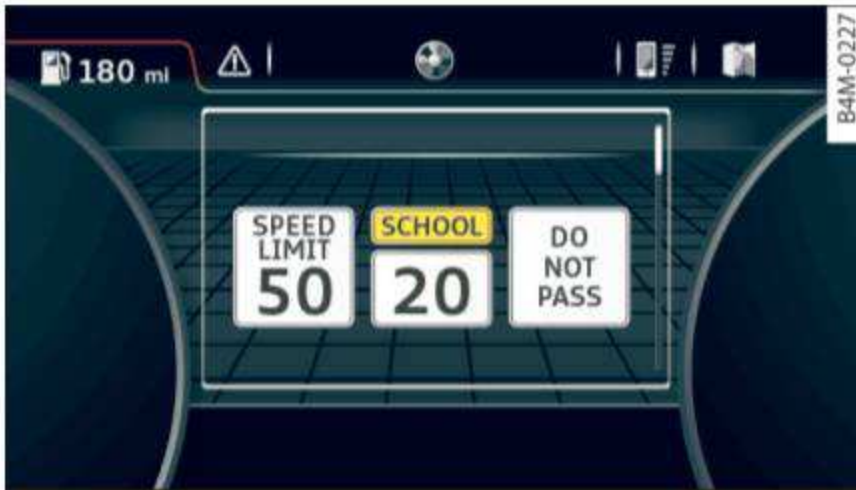

Fig. 95 Instrument cluster: traffic sign recognition

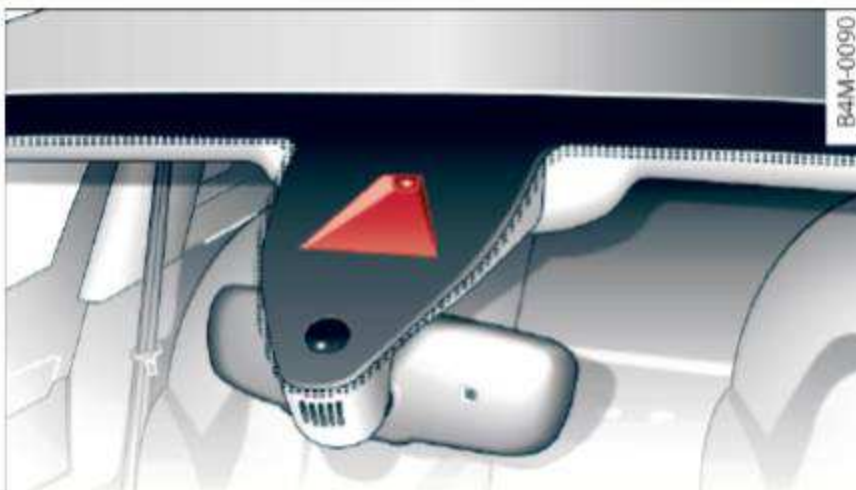

Fig. 96 Windshield: camera window for traffic sign recognition

Traffic sign recognition assists you when driving by displaying detected speed limits or signs prohibiting passing in the instrument cluster display ⇒ *fig. 95*. Within the limits of the system, the legal speed limits in school zones are detected and displayed.

### General information

Traffic sign recognition can detect standard speed limit signs that are within the camera's visual field. With assistance from navigation data, detected speed limits are evaluated and shown in the display. The traffic sign for the current detected speed limit will blink in the display if you exceed the warning threshold set in the Infotainment system ⇒ *page 98*.

The traffic sign recognition is subject to certain system limitations and may be unavailable or only partially available in the following situations:

- when visibility is poor, such as in snow, rain, fog or heavy spray
- when there is glare, for example from oncoming traffic or the sun
- at high speeds
- if the camera's visual field ⇒ *fig. 96* is covered, for example by dirt or stickers For information on cleaning, see ⇒ *page 344*.
- if the traffic signs are completely or partially covered, for example by trees, snow, dirt or other vehicles
- if speed traffic signs do not conform to the standards
- if traffic signs are damaged or bent
- if traffic signs are displayed on sign holders with electronic signs
- if the traffic signs or the configuration of the road have changed (navigation data is no longer up-to-date)

### ! WARNING

Pay attention to traffic and the area around your vehicle when traffic sign recognition is turned on. The traffic signs installed on the road always take precedence over the display. The driver is always responsible for assessing the traffic situation.

- Under some circumstances, traffic sign recognition may not detect traffic signs correctly or detect them at all. As a result, the system may not display the correct speed limit or any speed limit.
- Traffic sign recognition does not adapt your vehicle's speed to match the speed limit!
- The display in the instrument cluster is based on the units of measurement used for speed in that country. As a result, the display **50** in the instrument cluster can mean either km/h or mph, depending on the country.

### Operating

Applies to: vehicles with camera-based traffic sign recognition



Fig. 97 Instrument cluster: additional display

### Accessing traffic sign recognition

- ▶ Select: the first tab > **Traffic signs**.

### Setting a speed warning

You can set a warning threshold down to 10 mph (15 km/h). The traffic sign for the current detected speed limit will blink in the display if you exceed the set threshold.

- ▶ Select in the Infotainment system: **MENU** button > **Vehicle** > left control button > **Driver assistance** > **Speed warning** > **Traffic sign based warning**.

### Additional display

If a view other than the traffic sign recognition is selected in the instrument cluster display, the speed limit will be shown in another display ⇒ *fig. 97*. The current applicable speed limit will be shown there, if possible within the limits of the system.

### Tips

- An additional indicator appears in the head-up display\*.
- Your speed warning settings are stored automatically and assigned to the remote control key in use.

### Messages

Applies to: vehicles with camera-based traffic sign recognition

 **Traffic sign recognition: currently unavailable. Camera view limited due to surroundings**

**Function currently unavailable. Camera view restricted due to surroundings**

This message appears if the camera's visual field is covered ⇒ *page 97, fig. 96*. The system will switch itself off.

 **Traffic sign recognition: currently limited. See owner's manual**

This message appears if there is a malfunction in the navigation system, for example. The speed limit display is limited, which increases the risk of an incorrect display.

 **Traffic sign based speed warning: currently unavailable. See owner's manual**

There is no warning when the set threshold is exceeded.

**No traffic sign information available**

There is no valid navigation data and no speed limits were detected. Or there is a recommended speed but there is not a speed limit (for example driving on and off the expressway).

**Malfunction! See owner's manual**

The system cannot guarantee correct function and is switched off. See an authorized Audi dealer or authorized Audi Service Facility for assistance.

**Function not available in this country**

The vehicle is in a country where the function is not available.

## Lap timer

### Introduction

Applies to: vehicles with lap timer

*You can measure and analyze lap times with the lap timer in the display.*

### Opening the lap timer

- ▶ Open the first Vehicle tab (trip computer) using the  button on the multifunction steering wheel.
- ▶ Select on the multifunction steering wheel: left control button > **Lap times**.

## Operating the lap timer

- ▶ On the multifunction steering wheel, turn the left thumbwheel  ⇒ *page 12* until the desired menu item is displayed in the instrument cluster.
- ▶ Press the left thumbwheel to confirm the selection.

### WARNING

Your focus should always be on driving your vehicle safely. As the driver, you have complete responsibility for safety in traffic. Only use the functions such as the lap timer in such a way that you always maintain complete control over your vehicle in all traffic situations.

### Tips

You can retrieve information from the trip computer while the lap timer stopwatch is running.

## Lap times and timing

Applies to: vehicles with lap timer



Requirement: the lap timer must be open ⇒ *page 98*.

### Timing laps

- ▶ To start timing manually, select **Start lap 1** in the menu.
- ▶ To start timing automatically as soon as you begin to drive, select **Drive off to start lap 1** or **Start by driving off** in the menu.
- ▶ To measure the lap time, select **New lap** in the menu. This starts timing the next lap at the same time.

After completing a lap, the difference between the last lap and the previous best lap time will be indicated with a “-” or “+”.

### Pausing timing and displaying a split time

- ▶ To insert a pause , select **Pause** in the menu.
- ▶ To resume timing, select **Resume** in the menu.
- ▶ To display a split time, select **Split time** in the menu. The split time  appears for approximately 10 seconds in the instrument cluster. The timing of the current lap continues.

## Resetting timing

- ▶ Using the multifunction steering wheel, select **Reset times** in the menu.

### Tips

- A maximum of 99 lap times can be measured.
- If timing is paused, you can continue it later even if you switch the ignition off.
- Saved lap times cannot be individually deleted from the total results.
- The saved lap timer values will remain after switching the ignition off.

## Lap statistics

Applies to: vehicles with lap timer

### Displaying lap statistics

You can display the number of laps driven, the fastest lap “+”, the slowest lap “-”, and the average time “Ø” in the instrument cluster.

- ▶ On the multifunction steering wheel, select the left control button > **Lap statistics** or **Statistics**.
- ▶ Turn the thumbwheel down or up to display the individual lap times.
- ▶ To return to the lap timing that was begun, press the left thumbwheel.

### Resetting lap statistics

- ▶ On the multifunction steering wheel, select: the right control button > **Reset statistics**.

### Tips

The lap statistics list the lap times for the last 30 laps. The fastest and slowest lap time out of up to 99 measured laps are also displayed.

## Predictive efficiency assist

### Introduction

The predictive efficiency assist helps the driver to drive with anticipation and therefore helps to save fuel. The system accesses predictive trip data (including speed limits, inclines and the radius ▶

## Assistance systems

of curves) from the navigation system\*. Information from the camera-based traffic sign recognition\* is also applied to recognize traffic signs ⇒ *page 97*.

The messages displayed depend on the navigation data\* being up-to-date and the correct identification by the traffic sign recognition\*.

When adaptive cruise control\* is switched off, the predictive efficiency assist only provides notifications without controlled interventions. See ⇒ *page 100, Predictive messages (efficiency assist)*.

When adaptive cruise control\* is switched on, the system responds to upcoming situations automatically. See ⇒ *page 100, Predictive control (efficiency assist)*.

### Predictive messages (efficiency assist)

Applies to: vehicles with predictive efficiency assist

#### Indicator in the instrument cluster display

Predictive messages appear in the instrument cluster display to show the driver the appropriate time to coast when a situation ahead requires you to drive at a lower speed.



The messages are only shown if the cruise control system\* or adaptive cruise control\* is switched off.

An additional indicator appears in the head-up display\*.

Symbol	Meaning
	Remove your foot from the accelerator pedal to slow down, because there is a situation ahead that requires a lower speed.

If you see **Driver assistance** in the instrument cluster display, the following symbols will indicate which situation the system is currently reacting to.

Symbol	Meaning
MPH	<b>USA models:</b> Speed limit
km/h	<b>Canada models:</b> Speed limit

Symbol	Meaning
	Intersection
	Traffic circle

If there are multiple situations, then these situations will appear in order in the display.

### WARNING

Pay attention to traffic and the area around your vehicle when the efficiency assist is switched on. The driver is always responsible for assessing the traffic situation.

### Tips

- The wording of the message may vary depending on the driving mode set in drive select\* ⇒ *page 125* and the current selector lever position. No messages are displayed when in the "S" selector lever position or in **Dynamic** mode.
- When a route is planned using the navigation system\*, then the message feed is based on this route. Without route guidance, the system uses an assumed route for the message feed.
- There will not be a message for every situation ahead, for example if there is not enough distance remaining to react to the situation.
- No messages are displayed when at speeds under 20 mph (30 km/h).

### Predictive control (efficiency assist)

Applies to: vehicles with Audi adaptive cruise control and predictive efficiency assist



Fig. 98 Instrument cluster: predictive control

## Description

The predictive control <sup>1)</sup> uses the map information from the navigation system in order to react proactively when driving. Information from the camera-based traffic sign recognition\* is also applied to recognize traffic signs ⇒ *page 97*. When coming up to areas with speed limits or changes in the course of the road (such as curves, intersections or traffic circles), the system brakes automatically and then accelerates back up to the set speed.

## Overriding control



The driver can override the predictive control at any time by pressing the accelerator or brake pedal. If the system changes the vehicle speed to adapt to speed limits, you can change the speed using the lever ⇒ *page 106, fig. 105*.

## Always switch off the predictive control in the following situations:



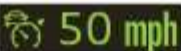

- When increased attention is needed from the driver.
- In poor weather conditions such as snow or heavy rain.
- When driving on roads in poor condition.

## Indicator in the instrument cluster display



When switching on the adaptive cruise control for the first time, the message **ACC: mph +  active** in the instrument cluster indicates the availability of the predictive control.

The  symbol appears when the system is regulating the speed to match a speed limit. If this is the case, the system is regulating a speed of 50 mph (80 km/h). The speed is then taken over by the adaptive cruise control. The speed in the speedometer LED ring adjusts to the speed to be maintained ⇒ *page 104, fig. 104*. The  ⇒ *fig. 98* symbol appears when there is an adaptation to the route ahead.

If you are in the **Driver assistance** display in the instrument cluster, then the following symbols will indicate which occurrence the system is currently responding to:

Symbol	Meaning
	<b>USA models:</b> Speed limit
	<b>Canada models:</b> Speed limit
	Curve
	Intersection
	Traffic circle

## WARNING

- Read the warnings on ⇒  in *General information on page 103* and on ⇒  in *Description on page 97*.
- Pay attention to traffic and the area around your vehicle when predictive control is switched on. The driver is always responsible for assessing the traffic situation.
- There is an increase in the risk of an accident, because the system does not consider "right of way" rules and also does not respond to traffic lights.
- The system only considers traffic signs that give a speed limit.
- The permitted speed can be exceeded if the adaptation to a speed limit is incorrect. The driver is responsible for adhering to the permitted speed.
- The speed at which a curve is driven through does not necessarily match your own driving style. Brake the vehicle yourself when needed to reduce the risk of an accident.

## Tips

- If a speed limit is detected, the stored speed is also adjusted in the speedometer LED line when the adaptive cruise control is not active.
- The adaptation by the system depends on the driving mode set in drive select\*.
- Switching off predictive control, for example when driving in low traffic zones, does

<sup>1)</sup> This is not available in some countries.

not cause the adaptive cruise control to switch off.

- After switching on the ignition, the system initially adjusts to a speed of 80 mph (130 km/h) when driving onto highways without a speed limit. Then the system adjusts to the last speed stored by the driver.
- There is no adaptation to speed limits when driving through highway interchanges and when driving on or off the expressway.
- There is no predictive control at speed limits under 20 mph (30 km/h).
- If a speed limit is only detected by the camera and the actual speed is significantly higher, then the speed limit will blink in the display until you have reached the required speed ⇒ *page 98*.
- Incorrect values from the camera-based traffic sign recognition\* or outdated navigation system map data can lead to incorrect or implausible control.
- When route guidance is switched on, the system adapts to the route provided by the navigation system. Driving without route guidance or leaving a route can result in implausible control.
- The system switches off when outside of a road system that is recorded in the navigation system map data.

### Settings in the Infotainment system

Applies to: vehicles with predictive efficiency assist

#### Predictive messages\*

- ▶ In the Infotainment system, select: **MENU** button > **Vehicle** > left control button > **Driver assistance** > **Efficiency assist**.

Predictive messages are shown when this function is switched on.

#### Setting predictive control\*

- ▶ Select in the Infotainment system: **MENU** button > **Vehicle** > left control button > **Driver assistance** > **Audi adaptive cruise control** > **Predictive control**.

**Set speed limit** - when this function is switched on, the system adjusts to the speed limits. This

can also be done with at tolerance, if desired. In this scenario, you may fall below or exceed the set speed in favor of increased efficiency.

**Adaptation to route ahead** - when this function is switched on, the system adapts to the route ahead, such as reducing the speed when driving around curves.

#### Tips

No predictive messages are shown on vehicles without a navigation system.

## Audi adaptive cruise control

### Description

Applies to: vehicles with Audi adaptive cruise control

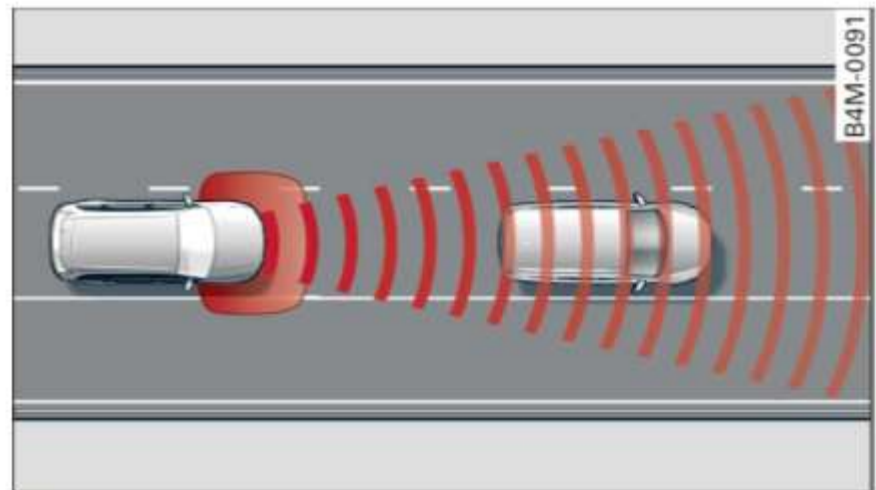

Fig. 99 Detection range

The adaptive cruise control system is a combination of speed and distance regulation. It assists the driver by both regulating the speed and maintaining a distance to the vehicle driving ahead, within the limits of the system. If the system detects a vehicle driving ahead, the adaptive cruise control can brake and accelerate your vehicle. This makes driving more comfortable both on long stretches of highway and in stop-and-go traffic.

#### What can adaptive cruise control do?

The adaptive cruise control system uses video, radar, ultrasound and navigation data. Vehicles driving ahead can be recognized up to 650 ft (200 m) away.

Predictive functions offer the driver additional comfort and contribute to the reduction in fuel consumption and CO<sub>2</sub> emissions ⇒ *page 100*.

On open roads with no traffic, it functions like a cruise control system. The stored speed is maintained. When approaching a vehicle driving ahead, the adaptive cruise control system automatically brakes to match that vehicle's speed and then maintains the set distance. As soon as the system does not detect a vehicle driving ahead, adaptive cruise control accelerates up to the stored speed.

In stop-and-go traffic, adaptive cruise control can brake until the vehicle is stationary and then can also start driving again automatically under certain conditions ⇒ *page 106*.

In traffic jams or stop-and-go traffic, traffic jam assist can assist the driver ⇒ *page 109*.

### Which functions can be controlled?

When you switch adaptive cruise control on, you can set the current speed as the “control speed” ⇒ *page 104, Switching on/off*.

When driving, you can stop cruise control ⇒ *page 107* or change the speed ⇒ *page 106* at any time.

You can also set the distance to the vehicle driving ahead and set the driving mode of the adaptive cruise control ⇒ *page 107*.

### General information

Applies to: vehicles with Audi adaptive cruise control



**Fig. 100** Front of the vehicle: sensors and video camera

The areas with the radar and ultrasonic sensors and the video camera ⇒ *fig. 100* must not be covered by stickers, deposits or any other objects, because this can interfere with the adaptive cruise control function. For information on clean-

ing, see ⇒ *page 344*. The same applies for any modifications made in the front area.

In some driving situations, the adaptive cruise control function is restricted:

- Vehicles can only be detected when they are within the sensor detection zones ⇒ *page 102, fig. 99*.
- The system has a limited ability to detect vehicles that are a short distance ahead, off to the side of your vehicle or moving into your lane.
- Objects that are difficult to detect such as motorcycles, vehicles with high ground clearance or an overhanging load are detected late or not detected at all.
- When driving through curves ⇒ *page 104*.
- When the vehicle is stationary ⇒ *page 104*.

### WARNING

Always pay attention to the traffic around you when adaptive cruise control is switched on. As the driver, you are still responsible for your own speed and the distance to other vehicles. The adaptive cruise control is used to assist you. The driver must always take action to avoid a collision. The driver is always responsible for braking at the correct time.

- For safety reasons, do not use adaptive cruise control when the road surface is in poor condition and/or in bad weather conditions (such as ice, fog, gravel, heavy rain and hydroplaning). Using the system under these conditions increases the risk of an accident.
- Switch adaptive cruise control off temporarily when driving in turning lanes, on expressway exits (except if predictive control is switched on) or in construction zones. This prevents the vehicle from accelerating to the stored speed when in these situations.
- The adaptive cruise control system will not brake by itself if you put your foot on the accelerator pedal. Doing so can override the speed and distance regulation.

- When approaching stationary obstacles such as stopped traffic, adaptive cruise control will respond with limited function.
- Adaptive cruise control does not respond to people, animals, or crossing or oncoming objects.
- The function of the radar sensors can be affected by reflective objects such as guard rails, the entrance to a tunnel, heavy rain or ice.

### ! Note

The sensors can be displaced by impacts or damage to the bumper, wheel housing and underbody. This can impair the adaptive cruise control. Have an authorized Audi dealer or authorized Audi Service Facility check their function.

### i Tips

For an explanation on conformity with the FCC regulations in the United States and the Industry Canada regulations, see ⇒ page 374.

## In curves

Applies to: vehicles with Audi adaptive cruise control

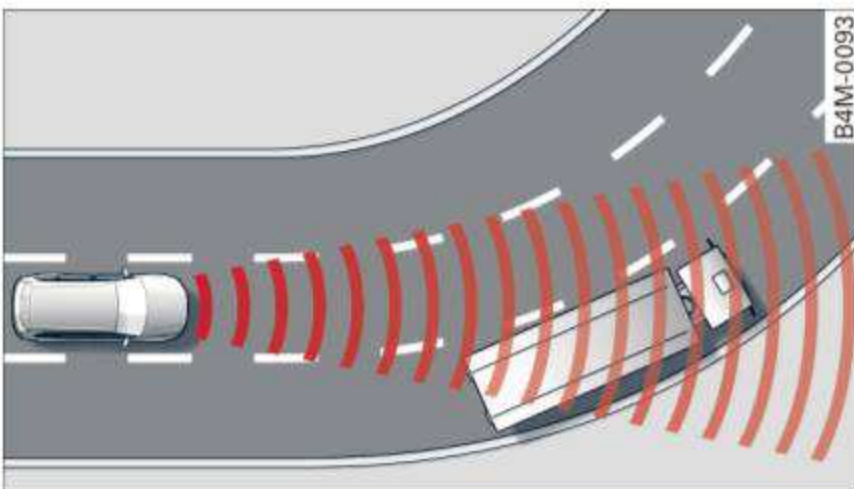

Fig. 101 Example: driving into a curve

When driving into a curve ⇒ *fig. 101* and out of a curve, the adaptive cruise control may react to a vehicle in the neighboring lane and apply the brakes. You can prevent that by pressing the accelerator pedal briefly.

## Stationary vehicles

Applies to: vehicles with Audi adaptive cruise control

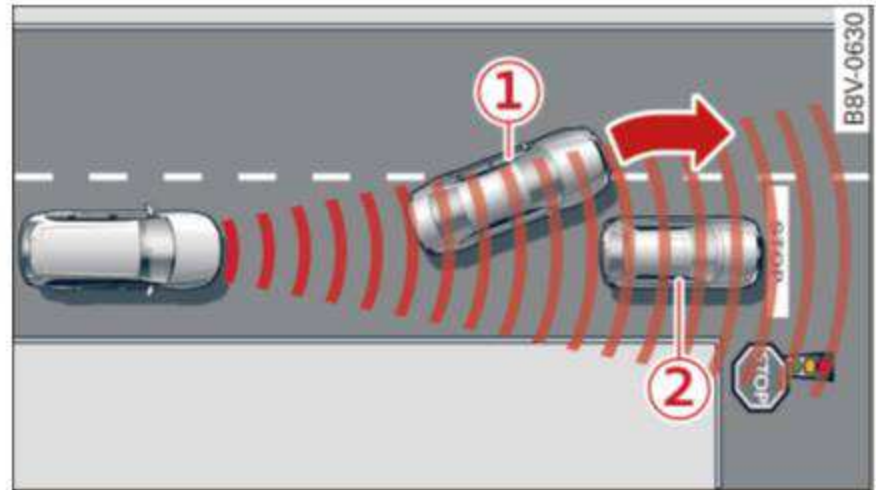

Fig. 102 Example: vehicle changing lanes and stationary vehicle

Within the limits of the system, adaptive cruise control can react to stationary vehicles ⇒ *fig. 102*, as long as you are driving slower than 30 mph (50 km/h) and the system classifies the possible passing maneuver as low. For example, if a vehicle that was already detected ① turns or changes lanes, the adaptive cruise control reacts to the stationary vehicle ahead of it ②.

## Switching on/off

Applies to: vehicles with Audi adaptive cruise control



Fig. 103 Operating lever: switching on and off



Fig. 104 Instrument cluster: adaptive cruise control

You can set any speed between 20 mph and 95 mph (30 km/h and 150 km/h).

Indicator lights and messages in the instrument cluster display inform you about the current situation and setting.

An additional indicator appears in the head-up display\*.

### Switching adaptive cruise control on

- ▶ Pull the lever toward you into position **1** ⇒ *fig. 103*.

### Storing the speed and activating regulation

- ▶ To store the current speed, press the **SET** button ⇒ *fig. 103*. The stored speed is shown in the speedometer in the LED line **A** and appears briefly in the status line **D** ⇒ *fig. 104*.
- ▶ To activate the regulation while stationary, also press the brake pedal.

### Switching adaptive cruise control off

- ▶ Push the lever away from you into position **0** until it clicks into place. The message **ACC: off** appears.

### **B** Indicator lights

 - Adaptive cruise control is switched on. No vehicles are detected ahead. The stored speed is maintained.

 - A vehicle driving ahead was detected. The adaptive cruise control system regulates the speed and distance to the vehicle driving ahead and accelerates/brakes automatically.

 - Adaptive cruise control is switched on. A vehicle was detected ahead. Your vehicle is stationary and will not start driving automatically.

 - Adaptive cruise control is switched on. No vehicles were detected ahead. Your vehicle is stationary and will not start driving automatically.

 - The automatic braking is not enough to maintain a sufficient distance to a vehicle driving ahead. You must intervene ⇒ *page 108, Driver intervention request*.

### **C** Instrument cluster display

If the **Driver assistance** display is not shown in the instrument cluster display, you can open it using the multifunction steering wheel buttons ⇒ *page 12*.

Based on the graphic display, you can determine if the system is maintaining a distance to the vehicle driving ahead and what that distance is.

**No vehicle** - no vehicle was detected driving ahead.

**Silver vehicle** - a vehicle was detected driving ahead.

**Red vehicle** - request for driver intervention ⇒ *page 108*.

The five **distance bars** on the **gauge C** represent the set distance (refer to ⇒ *page 107* for information on how to change the distance). If you fall below the selected distance, the distance bars become red from the bottom upward.

#### **WARNING**

If you press the **SET** button when driving at speeds below 20 mph (30 km/h), the vehicle accelerates automatically up to 20 mph (30 km/h), which is the minimum speed that can be set.

#### **Tips**

- If you switch the ignition or the adaptive cruise control system off, the set speed is erased for safety reasons.
- The Electronic Stabilization Control (ESC) and the Anti-Slip-Regulation (ASR) are automatically switched on when the adaptive cruise control is switched on.

### Changing the speed

Applies to: vehicles with Audi adaptive cruise control



Fig. 105 Operating lever: changing the speed

- ▶ To increase/decrease the speed in 1 mph (1 km/h) increments, briefly **tap** the lever toward  $\oplus/\ominus$  ⇒ *fig. 105* to the first level.
- ▶ To increase/decrease the speed in 5 mph (5 km/h or 10 km/h) increments, briefly **tap** the lever toward  $\oplus/\ominus$  up to the second level.
- ▶ To increase or decrease the speed continuously, **hold** the lever toward  $\oplus/\ominus$  to the first or second level until the red LED  $\text{\textcircled{A}}$  reaches the desired speed ⇒ *page 104, fig. 104*.

You can also preselect the speed when adaptive cruise control is not active by moving the lever in the desired direction  $\oplus/\ominus$ . Activate the previously selected speed by pulling the lever into position  $\text{\textcircled{1}}$  ⇒ *page 104, fig. 103*.

After each change, the new stored speed appears briefly in the status line ⇒ *page 104, fig. 104*  $\text{\textcircled{D}}$ . When adaptive cruise control is active, the  $\text{\textcircled{E}}$  indicator light turns on and when adaptive cruise control is not active, the  $\text{\textcircled{F}}$  indicator light turns on. In the Audi virtual cockpit\*, the  $\text{\textcircled{G}}$  indicator light turns on instead.

### Driving in stop-and-go traffic

Applies to: vehicles with Audi adaptive cruise control



Fig. 106 Instrument cluster: safe start monitor

The adaptive cruise control system also assists you in stop-and-go traffic. If a vehicle driving ahead stops, your vehicle will brake and stay at a stop within the limits of the system.

#### Starting to drive with adaptive cruise control<sup>1)</sup>

As long as the message **ACC: automatic go** is displayed, your vehicle will begin driving when the vehicle driving ahead starts to move ⇒  $\text{\textcircled{A}}$ .

If you are stopped for several seconds, your vehicle will no longer drive autonomously for safety reasons, and the message will turn off.

- ▶ To reactivate **ACC: automatic go** temporarily, pull the lever to position  $\text{\textcircled{2}}$  ⇒ *page 107, fig. 107*.
- ▶ To resume manual control of the vehicle, tap the accelerator pedal.

#### Safe start monitor

If an obstacle is detected when you start driving, you will be alerted to the danger by the  $\text{\textcircled{H}}$  indicator light and the image in the instrument cluster display ⇒ *fig. 106* ⇒  $\text{\textcircled{A}}$ . An audio signal will also sound. Your vehicle will drive more slowly when starting. This may also happen in some situations when there is no apparent obstacle.

- Press the brake pedal to slow your vehicle down.

1) This is not available in some countries.

**! WARNING**

If the message **ACC: automatic go<sup>1)</sup>** appears, your vehicle will start driving even if there is an obstacle between your vehicle and the vehicle driving ahead. This increases the risk of an accident.

**i Tips**

- For safety reasons, your vehicle will only start to drive automatically if:
  - the driver's safety belt is fastened
  - all doors and the hood are closed
  - your vehicle is not stopped for a long period.

**Interrupting cruise control**

Applies to: vehicles with Audi adaptive cruise control



Fig. 107 Selector lever

Requirement: adaptive cruise control must be switched on.

**Overriding cruise control**

- ▶ To accelerate manually, pull the lever toward you into position ② and hold it there or press the accelerator pedal. The message **ACC: override** appears.
- ▶ To resume cruise control, release the lever or take your foot off the accelerator pedal.

**Canceling cruise control while driving**

- ▶ Move the lever into position ③. The message **ACC: standby** appears, Or
- ▶ Press the brake pedal.

- ▶ To resume the stored speed, move the lever toward you into position ②.

**Canceling cruise control when stopped**

- ▶ Push the lever away from you into position ③. The message **ACC: standby** appears,
- ▶ To resume cruise control, press the brake pedal and pull the lever toward you into position ②.

**! WARNING**

It is dangerous to activate cruise control and resume the stored speed when the current road, traffic or weather conditions do not permit this. This increases the risk of an accident.

**Setting the distance**

Applies to: vehicles with Audi adaptive cruise control



Fig. 108 Operating lever: setting the distance

- ▶ Tap the switch to display the current set distance ⇒ *fig. 108*.
- ▶ To increase or reduce the distance in increments, tap the switch upward/downward again. The distance between the two vehicles will change in the instrument cluster display.

When approaching a vehicle driving ahead, the adaptive cruise control system brakes to match that vehicle's speed and then adjusts to the set distance. If the vehicle driving ahead accelerates, then the adaptive cruise control will also accelerate up to the speed that you have set.

The higher the speed, the greater the distance ⇒ **! A**. The **Distance 3** setting is recommended. That is equal to the general recommendation of "half the speed shown on the speedometer". ▶

1) This is not available in some countries.

The distances provided are specified values. Depending on the driving situation and how the vehicle ahead is driving, the actual distance may be more or less than these target distances.

If you change the time gaps, the newly set value appears briefly in the instrument cluster display, for example  for **Distance 3**. This only occurs if the **Driver assistance** display is not currently shown in the display ⇒ *page 104, fig. 104*.

**Distance 1:** this setting corresponds to a distance of 92 ft (28 m) when traveling at 62 mph (100 km/h), or a time distance of 1 second.

**Distance 2:** this setting corresponds to a distance of 118 ft (36 m) when traveling at 62 mph (100 km/h), or a time distance of 1.3 seconds.

**Distance 3:** this setting corresponds to a distance of 164 ft (50 m) when traveling at 62 mph (100 km/h), or a time distance of 1.8 seconds.

**Distance 4:** this setting corresponds to a distance of 219 ft (67 m) when traveling at 62 mph (100 km/h), or a time distance of 2.4 seconds.

**Distance 5:** this setting corresponds to a distance of 328 ft (100 m) when traveling at 62 mph (100 km/h), or a time distance of 3.6 seconds.

### **WARNING**

When setting the distance, the driver is responsible for adhering to any applicable legal regulations.

### **Tips**

Depending on the selected driving mode in drive select\* and the set distance, the driving behavior will vary from dynamic to comfortable when accelerating ⇒ *page 127*.

## Setting Audi adaptive cruise control

Applies to: vehicles with Audi adaptive cruise control

- ▶ Select in the Infotainment system: **MENU** button > **Vehicle** > left control button > **Driver assistance** > **Audi adaptive cruise control**.

## Storing the last distance<sup>1)</sup>

The last distance that was set will be stored after the ignition is switched off. If the distance is not stored, **Distance 3** is automatically set every time the ignition is switched on.

## Driving program

Applies to: vehicles without Audi drive select

Depending on the selected driving program and distance, driving behavior when accelerating will vary from dynamic to comfortable.

## Selecting the driving mode

Applies to: vehicles with Audi drive select

For vehicles with drive select, refer to ⇒ *page 127*.

### **Tips**

Your settings are automatically stored and assigned to the remote control key being used.

## Driver intervention request

Applies to: vehicles with Audi adaptive cruise control



**Fig. 109** Instrument cluster: request for driver intervention

The request for driver intervention instructs you to take over if the adaptive cruise control braking function is not able to maintain a sufficient distance to the vehicle driving ahead ⇒ *fig. 109*.

<sup>1)</sup> In preparation at the time of printing. This function is not available in every vehicle.

## Traffic jam assist

Applies to: vehicles with traffic jam assist

Traffic jam assist supports the driver when driving in traffic jams or in heavy traffic.



Fig. 110 Turn signal lever: traffic jam assist button



Fig. 111 Instrument cluster: traffic jam assist

In a speed range under 40 mph (65 km/h), traffic jam assist can help to keep the vehicle within a lane calculated by the system. Within the limits of the system, the system controls the steering automatically when adaptive cruise control is switched on. Since traffic jam assist is only an assist system, the driver must always keep his or her hands on the steering wheel and be ready to steer. The driver can override the control at any time by actively steering.

The system is designed for driving on expressways and highways.

### Switching traffic jam assist on and off

- ▶ Press the button to switch the system on and off ⇒ *fig. 110*.
- ▶ To turn the system off completely, select in the Infotainment system: **MENU** button > **Vehicle** > left control button > **Driver assistance** > **Traffic jam assist**.

If traffic jam assist was deactivated through the Infotainment system, you can continue operating the active lane assist using the ⇒ *fig. 110* button ⇒ *page 118*. The traffic jam assist functions are no longer available.

### Requirements for using traffic jam assist:

- Traffic jam assist must be switched on in the Infotainment system.
- Adaptive cruise control must be switched on and active ⇒ *page 104*.



### Always switch off traffic jam assist in the following situations:

- When increased attention is needed from the driver.
- In poor weather conditions such as snow or heavy rain.
- When driving on roads in poor condition.
- In construction zones.
- In city driving.

### Traffic jam assist availability:

If you are in the **Driver assistance** display in the instrument cluster, the  indicator light and the message **Traffic jam assist available** appears if a traffic congestion situation was recognized. You can open the **Driver assistance** display using the multifunction steering wheel buttons ⇒ *page 12*. To activate traffic jam assist, you must press the ⇒ *fig. 110* button and switch on the adaptive cruise control ⇒ *page 104*.

### Indicator lights

 and  - Traffic jam assist is switched on. Vehicles driving ahead were detected. Your vehicle adapts while driving ⇒ *fig. 111*.

 - Traffic jam assist switches off if the driver does not take over steering after multiple driver intervention requests. The system brakes the vehicle until it is stationary.

### WARNING

Always keep your hands on the steering wheel so you can be ready to steer at any time. The driver is always responsible for staying in a lane and for assessing traffic situations. Read

and follow the warnings on ⇒ ⚠ in *General information on page 103*. Never use traffic jam assist in the following situations or you will increase the risk of an accident.

- Driving offroad or on unpaved roads. Traffic jam assist is only designed for use on paved roads.
- In city driving or in construction zones.
- On curving stretches of road.
- In narrow lanes.
- In unclear traffic situations such as at intersections or toll stations.

### **i** Tips

You are not necessarily guided to the center of your lane.

## Distance display and distance warning

Applies to: vehicles with Audi adaptive cruise control

*This function measures the time between the vehicle driving ahead and shows this in the instrument cluster display.*



Fig. 112 Instrument cluster: distance indicator/warning

### Description

At speeds above approximately 40 mph (65 km/h), this function measures the distance to the vehicle ahead as time.

- ▶ Switch the adaptive cruise control display on in the instrument cluster display ⇒ *page 12*.

The **ACC** indicator light turns on if you fall below the set distance.

### Setting the warning threshold

You can set, change or delete the warning threshold in the Infotainment system.

- ▶ In the Infotainment system, select: **MENU** button > **Vehicle** > left control button > **Driver assistance** > **Distance warning**.

### **!** WARNING

- Read and follow the warnings on ⇒ ⚠ in *General information on page 103*.
- The driver is always responsible for adhering to the regulations applicable in that country.

### **i** Tips

You may fall below the warning threshold briefly when passing or when quickly approaching a slow vehicle. There is no warning in this scenario. A warning is given only if you fall below the warning threshold for an extended period of time.

## Messages

Applies to: vehicles with Audi adaptive cruise control

**ACC with traffic jam assist: unavailable. See owner's manual**

The system cannot guarantee that it will detect vehicles correctly and it has switched off. The radar sensors have shifted or are faulty. Drive to an authorized Audi dealer or authorized Audi Service Facility immediately to have the malfunction corrected.

**ACC with traffic jam assist: currently unavailable. See owner's manual**

This message appears if the adaptive cruise control cannot be activated, for example if the hood is open.

**ACC w. traffic jam assist: currently unavailable. Sensor vision restricted due to surroundings. See owner's manual**

This message appears if the radar sensor view is obstructed, for example by leaves, snow, heavy spray or dirt. Clean the sensors ⇒ *page 103, fig. 100*.

**ACC with traffic jam assist: currently unavailable. Grade too steep**

The road exceeds the maximum possible grade for safe operation. The systems cannot be switched on.

 **ACC with traffic jam assist: only available in D, S or M**

Select the "D/S" or "M" selector lever position.

 **ACC with traffic jam assist: currently unavailable. Parking brake applied**

The systems switch off if you set the parking brake. The systems are available again after you release the parking brake.

 **ACC with traffic jam assist: currently unavailable. Stabilization control (ESC) input**

This message appears if the Electronic Stabilization Control (ESC) is taking action to stabilize the vehicle. The systems switch off in this scenario.

 **ACC with traffic jam assist: manual control!**

This message appears if the vehicle rolls back when starting on a slight incline, even though the systems are active. Press the brake pedal to prevent the vehicle from rolling or starting to move.

 **ACC with traffic jam assist: currently unavailable. Downhill assist activated**

You cannot activate the system when hill hold assist is active.

 **ACC with traffic jam assist: manual control!**

This message appears if the driver does not take over steering after multiple driver intervention requests and the system switches off. The vehicle brakes until it is stationary.

 **Traffic jam assist: unavailable. See owner's manual**

The system can no longer ensure that the vehicle will stay in the lane and switches off. Have your vehicle checked by an authorized Audi dealer or authorized Audi Service Facility if the malfunction is continuous.

 **Traffic jam assist: Please take over steering!**

This message appears as soon as the system stops detecting steering activity when the system limits are reached. Always keep your hands on

the steering wheel so you can be ready to steer at any time.

 **Traffic jam assist: currently unavailable. Please fasten seat belt**

The system switches off when the driver's safety belt is unfastened.

 **ACC: efficiency assist not available in this country**

The adaptation to speed limits and routes ahead is not available in this country.

 **ACC: predictive control currently unavailable. See owner's manual**

The adaptation to speed limits and routes ahead switches off at speed limits under 20 mph (30 km/h).

The message can also appear if the adaptation to speed limits and routes ahead has a temporary failure. Have your vehicle checked by an authorized Audi dealer or authorized Audi Service Facility if the malfunction is continuous.

**Distance warning: malfunction! Please contact Service**

The system cannot guarantee that it will detect vehicles correctly and it has switched off. The radar sensors have shifted or are faulty. Drive to an authorized Audi dealer or authorized Audi Service Facility immediately to have the malfunction corrected.

**Distance warning: currently unavailable. Sensor view restricted due to surroundings. See owner's manual**

This message appears if the radar sensor view is obstructed, for example by leaves, snow, heavy spray or dirt. Clean the sensors ⇒ *page 103, fig. 100.*

**Distance warning: currently unavailable. See owner's manual**

This message appears if the system has a temporary failure. If this occurs multiple times, drive to an authorized Audi dealer or authorized Audi Service Facility immediately to have the malfunction corrected. ►

### ACC: Please fasten seat belt

The system is not completely available if the driver's seat belt is unfastened.

### Stationary object ahead

This message appears if you would like to switch the system on and there is a stationary object directly in front of your vehicle.

### Door open

The system is not available when the door is open.

## Audi pre sense

### Introduction



Applies to: vehicles with Audi pre sense

Within the limits of the system, the pre sense functions can initiate measures in particularly dangerous situations to protect the vehicle passengers and other road users.

- Due to the interlinking of various vehicle systems, critical driving situations can be detected by **pre sense basic** and measures for preventative occupant protection are can be initiated.
- The **pre sense front** system uses the data from the adaptive cruise control\* radar sensors and the camera to calculate the probability of a collision. Within the limits of the system, an impending collision with vehicles can be detected in both urban and rural speed ranges. In this case, the system warns the driver visually, acoustically and with a jerk on the brakes if necessary. If needed, it can initiate a partial or full deceleration to reduce the collision speed or to avoid the collision under certain circumstances. In conjunction with pre sense basic/rear, the front safety belts are also reversibly tensioned when needed. The pre sense front is also active when adaptive cruise control\* is switched off.
- **Pre sense rear** contains pre sense basic functions. It uses the data from the side assist\* radar sensors and calculates within the limits of the system the probability of a rear end collision with the vehicle behind you. Pre sense rear is also active when side assist\* is switched off.

- Within the limits of the system, **pre sense city** uses the camera data and can detect an impending collision with vehicles and pedestrians. In this case, the system warns the driver visually, acoustically and with a jerk on the brakes if necessary. If needed, it can initiate a full deceleration to reduce the collision speed or to avoid the collision under certain circumstances. In conjunction with pre sense basic/rear, the front safety belts are also reversibly tensioned when needed.

### WARNING

Read the general information in  in *General information on page 103*,  in *General information on page 122*.

### Tips

- Certain pre sense functions switch off when driving in reverse.
- The pre sense functions may not be available if there is a malfunction in the ESC system or the airbag control module.
- Note that the reversible belt tensioner on the front passenger's side deactivates when the front passenger's airbag is deactivated.
- Switch the pre sense off when you are not using public streets or when loading the vehicle onto a vehicle carrier, train, ship or other type of transportation. This can prevent an undesired intervention from the pre sense system.

### Audi pre sense basic

Applies to: vehicles with Audi pre sense basic

The pre sense basic functions are activated at a speed of approximately 20 mph (30 km/h) or higher.

The following functions can be triggered under certain conditions within the limits of the system:

- Tensioning of the safety belts (for example, during heavy braking): the front safety belts have reversible belt tensioners. If a collision does not occur, the safety belts loosen slightly and are ready to trigger again. ►

- Closing the windows and sunroof\*
- Activating the emergency flashers <sup>1)</sup>.

The message **Audi pre sense**  ⇒ page 113, fig. 113 will warn you about the danger.

Audi drive select\*: the trigger times are adjusted depending on the mode selected.

### Audi pre sense front

Applies to: vehicles with Audi pre sense front



Fig. 113 Instrument cluster: approach warning

### Description

Within the limits of the system, pre sense front can warn you of impending collisions and initiate the corresponding braking maneuvers or the supporting measures when avoiding a collision.

If detected in time, the system can rank the dangerous situation as critical if a vehicle driving ahead brakes suddenly, if your own vehicle is approaching a significantly slower vehicle at high speed or when there is an oncoming vehicle during a turning maneuver.

If detection is not possible, then pre sense front does not react.

### Warnings

The system recognizes various dangerous situations. The **early warning** occurs if:

- a vehicle driving ahead brakes suddenly
- your own vehicle approaches a significantly slower vehicle or stationary vehicle in the direction of travel

When this warning occurs, it may only be possible to avoid a collision by swerving or braking strongly. The message **Audi pre sense**  ⇒ fig. 113 and a warning tone will warn you about the danger.

If you do not react enough or not at all to a dangerous situation that was detected by the system, pre sense front provides assistance by applying the brakes.

If a collision is imminent, the system will first provide an **acute warning** by braking sharply. You will also be warned by an indicator in the instrument cluster display ⇒ fig. 113. If you do not react to the acute warning, pre sense front can brake with increasing force within the limits of the system <sup>1)</sup>. This reduces the vehicle speed in the event of a collision. At low vehicle speeds, pre sense front can initiate a complete deceleration shortly before a collision with a vehicle driving ahead <sup>1)</sup>. If pre sense front determines that you are not braking strongly enough when a collision is imminent, it can increase the braking force.

The following functions trigger in conjunction with pre sense basic/rear at corresponding vehicle speeds:

- Reversible tensioning of the front safety belts
- Closing the windows and sunroof\*

Audi drive select\*: depending on the selected mode, the reversible belt tensioner and the closing of the windows and sunroof\* are not active.

### Evasive steering support

Evasive steering support helps you to steer the vehicle around an obstacle in a critical situation. If you avoid an obstacle after the acute warning, then the evasive steering support assists you by applying slight steering adjustment to correct your steering wheel angle as long as you are actively steering. Evasive steering support is available at speeds between approximately 20 mph (30 km/h) and 90 mph (150 km/h). ▶

<sup>1)</sup> This is not available in some countries.

### Turn assist

When starting to drive and up to speeds of maximum 6 mph (10 km/h), the turn assist uses a braking intervention to prevent your vehicle from colliding with an oncoming vehicle when turning left or right (available in certain countries). The braking intervention causes your vehicle to stay in its lane.

#### **WARNING**

- Pre sense front cannot overcome the laws of physics. It is a system designed to assist and it cannot prevent a collision in every circumstance. The driver must always intervene. The driver is always responsible for braking at the correct time. Do not let the increased safety provided tempt you into taking risks. This could increase your risk of a collision.
- The system can deploy incorrectly due to system-specific limits.
- Please note that the sensors and the camera do not always detect all objects or lane markings. This increases the risk of an accident.
- Pre sense front does not react to people, animals or objects that are crossing the vehicle's path or that are difficult to detect ⇒  *in General information on page 103.*
- Reflective objects such as guard rails or the entrance to a tunnel, heavy rain and ice can affect the function of the radar sensors and the system's ability to detect a collision risk.

#### **Note**

The sensors can be displaced by impacts or damage to the bumper, wheel housing and underbody. Pre sense front can be impaired by this. Have an authorized Audi dealer or authorized Audi Service Facility check their function.

#### **Tips**

- You can cancel the braking with increasing force that is initiated by the system by brak-

ing yourself, by accelerating noticeably or by swerving.

- Keep in mind that pre sense front can brake unexpectedly. Always secure any cargo or objects that you are transporting to reduce the risk of damage or injury.
- Specific pre sense front functions switch off when the ESC is restricted or switched off ⇒ *page 141* or the hill hold assist is switched on ⇒ *page 142.*

### Audi pre sense rear

Applies to: vehicles with Audi side assist

If the risk of a collision with a vehicle ahead is detected, the following functions can be triggered:

- Reversible tensioning of the front safety belts at the corresponding speeds.
- Closing the windows and sunroof\*
- Activating the emergency flashers with increased frequency <sup>1)</sup>.

The message **Audi pre sense**  ⇒ *page 113, fig. 113* will warn you about the danger.

Audi drive select\*: the function is not active depending on the mode selected.

#### **WARNING**

- To reduce the risk of an accident, please note that the side assist\* radar sensors do not always detect every object.
- Pre sense rear does not react to people, animals or objects that are crossing the vehicle's path or that are difficult to detect.
- Reflective objects such as guard rails, heavy rain and ice can impair the function of the radar sensors and the ability to detect a collision risk.

#### **Note**

The radar sensors can be displaced by impacts or damage to the bumper, wheel housing and underbody. Pre sense rear can be impaired by

<sup>1)</sup> This is not available in some countries.

this. Have an authorized Audi dealer or authorized Audi Service Facility check their function.

### Tips

- The pre sense rear functions switch off when towing a trailer.
- The pre sense rear functions may also switch off if there is a malfunction in the side assist\* system.

### Audi pre sense city

Applies to: vehicles with Audi pre sense city

#### Description

Within the limits of the system, pre sense city can warn you of impending collisions with vehicles and pedestrians and initiate the applicable braking maneuver if needed. Pre sense city is active at speeds of approximately 6 mph (10 km/h) and higher.

A pedestrian warning can occur at speeds up to 50 mph (85 km/h), and vehicle warnings can occur at speeds up to 155 mph (250 km/h). A pre sense city braking maneuver is possible at speeds up to 50 mph (85 km/h).

#### Warnings

The system recognizes various dangerous situations. The **early warning** occurs if:

- a vehicle driving ahead brakes suddenly
- your own vehicle approaches a significantly slower vehicle or stationary vehicle in the direction of travel
- a pedestrian is standing in the lane or is moving into the lane

When this warning occurs, it may only be possible to avoid a collision by swerving or braking strongly. The message **Audi pre sense**  ⇒ *page 113, fig. 113* and a warning tone will warn you about the danger.

Additionally, a jerk on the brakes may occur as an **acute warning** when there is an impending collision. If you do not react to the acute warning, pre sense city can brake to the point of complete deceleration within the limits of the system. This

reduces the vehicle speed in the event of a collision. The message **Audi pre sense**  also appears.

The following functions are triggered in conjunction with pre sense basic/rear:

- Reversible tensioning of the front safety belts
- Closing the windows and sunroof\*

Audi drive select\*: the function is not active depending on the mode selected.

### WARNING

- Pre sense city cannot overcome the laws of physics. It is a system designed to assist and it cannot prevent a collision in every circumstance. The driver must always intervene. The driver is always responsible for braking at the correct time. Do not let the increased safety provided tempt you into taking risks. This could increase your risk of a collision.
- The system can deploy incorrectly due to system-specific limits.
- To reduce the risk of an accident, please note that the camera does not always detect every object.
- Pre sense city does not react to animals, crossing or oncoming vehicles, objects such as bars, railings or railcars, and objects that are difficult to detect ⇒  *in General information on page 103.*
- In trailer mode, the braking behavior of the trailer can be different than usual during automatic braking.

### WARNING

Pre sense city may be restricted or not available in the following example situations:

- in heavy fog, rain, spray, or snow
- when there are visual obstructions, such as glare, reflections or variations in light
- when it is dark
- if the camera window or the windshield is dirty, iced over, damaged or covered
- when driving on snow, ice or loose ground
- in curves
- if the ESC was restricted or switched off
- when towing a trailer

- when the driver's seat belt is unfastened
- up to ten seconds after switching on the ignition

### Note

Impacts or damage to the camera mount on the windshield can displace the sensor. Pre sense city can be impaired by this. Have an authorized Audi dealer or authorized Audi Service Facility check their function.

### Tips

- You can cancel the system braking intervention if you accelerate considerably or swerve away.
- Keep in mind that pre sense city can brake unexpectedly. Always secure any cargo or objects that you are transporting to reduce the risk of damage or injury.
- Specific pre sense city functions switch off when the ESC is limited or switched off ⇒ *page 141* or the hill descent assist is switched on ⇒ *page 142*.
- When there is a malfunction in the camera, the pre sense city functions also switch off.

## Settings in the Infotainment system

Applies to: vehicles with Audi pre sense

- ▶ Select in the Infotainment system: **MENU** button > **Vehicle** > left control button > **Driver assistance** > **Audi pre sense**.

**Switch on/off Audi pre sense** - the pre sense functions can be turned on and off.

If the system is switched off, it switches on again automatically once the ignition is switched on again.

**Prewarning** - the early warning can be switched off or the pre sense city/front warning point can be set (**Early/Medium/Late**).

Set the warning time for the early warning to **Early** at first. If this causes undesired early warnings to appear, then set the warning time to **Medium**. The **Late** warning time should only be set in special circumstances.

### Tips

Your settings are automatically stored and assigned to the remote control key being used.

## Messages

Applies to: vehicles with Audi pre sense

### **Audi pre sense: malfunction! Please contact Service**

This message appears when the pre sense function is affected. For example, this could be caused by a faulty sensor. Drive to an authorized Audi dealer or authorized Audi Service Facility immediately to have the malfunction corrected.

### **Audi pre sense: currently limited. Sensor view limited due to surroundings. See owner's manual**

This message appears if the radar sensor and camera view is obstructed, for example by leaves, snow, heavy spray or dirt. If necessary, clean the sensors and the area around the camera ⇒ *page 103, fig. 100* or ⇒ *page 121, fig. 121*.

### **Audi pre sense: currently limited. Trailer towing mode**

For vehicles with a trailer hitch installed at the factory, the pre sense rear functions switch off when the electrical connector at the socket is plugged in. There is no guarantee the functions will switch off when using a retrofitted trailer hitch.

### **Audi pre sense: currently restricted**

This message appears if the ESC is restricted or switched off, for example.

### **Audi pre sense: currently limited. See owner's manual**

This message appears when there is a temporary failure in a subsystem, such as the ESC. If this message appears repeatedly, drive to an authorized Audi dealer or authorized Audi Service Facility to have the malfunction corrected.

### **Audi pre sense: emergency braking system off**

This message appears if the pre sense functions are switched off through the Infotainment system or if the system is not ready.

## Audi active lane assist

### Description

Applies to: vehicles with Audi active lane assist

Active lane assist (lane departure warning) detects lane marker lines within the limits of the system using a camera in the windshield. If you are approaching a detected lane marker line and it appears likely that you will leave the lane, the system will warn you with corrective steering. You can override this steering at any time. If you pass over a line, the steering wheel will vibrate lightly. In order for this warning vibration to occur, it must first be switched on in the Infotainment system. Active lane assist is ready for operation when the lane marker line is detected on at least one side of the vehicle.

The system is designed for driving on expressways and highways and therefore only activates at speeds above approximately 40 mph (65 km/h).

Applies to: vehicles with side assist: if you activate a turn signal when active lane assist is ready and it classifies a lane change as critical because of vehicles traveling alongside you or approaching you, there will be noticeable corrective steering shortly before you leave the lane. This will attempt to keep your vehicle in the lane.

Applies to: vehicles without side assist: the ready system does not warn you if you activate a turn signal before crossing the lane marker line. In this case, it assumes that you are changing lanes intentionally.

Applies to: vehicles with adaptive cruise control: there is no corrective steering or warnings if the system recognizes a distinct passing maneuver. If the conditions are met, traffic jam assist switches on at speeds under approximately 40 mph (65 km/h) ⇒ *page 109*.

### WARNING

- The system warns the driver that the vehicle is leaving the lane using corrective steering. The driver is always responsible for keeping the vehicle within the lane.
- The system can help you keep the vehicle in the lane, but it does not drive by itself. Always keep your hands on the steering wheel.
- Corrective steering may not occur in certain situations, such as during heavy braking.
- There may be cases where the camera does not recognize all lane marker lines. Corrective steering can only take place on the side of the vehicle where lane marker lines are detected.
- Other road structures or objects could possibly be identified unintentionally as lane marker lines. As a result, corrective steering may be unexpected or may not occur.
- The camera view can be restricted, for example by vehicles driving ahead or by rain, snow, heavy spray or light shining into the camera. This can result in active lane assist not detecting the lane marker lines or detecting them incorrectly.
- In certain situations where visibility is low, the vehicle may switch from an “early” to “late” steering correction.
- Under certain conditions such as ruts in the road, an inclined roadway or crosswinds, the corrective steering alone may not be enough to keep the vehicle in the middle of the lane.
- For safety reasons, active lane assist must not be used when there are poor road and/or weather conditions such as slippery roads, fog, gravel, heavy rain, snow and the potential for hydroplaning. Using active lane assist under these conditions may increase the risk of a crash.

**Switching on/off**

Applies to: vehicles with Audi active lane assist



Fig. 114 Turn signal lever: button for active lane assist

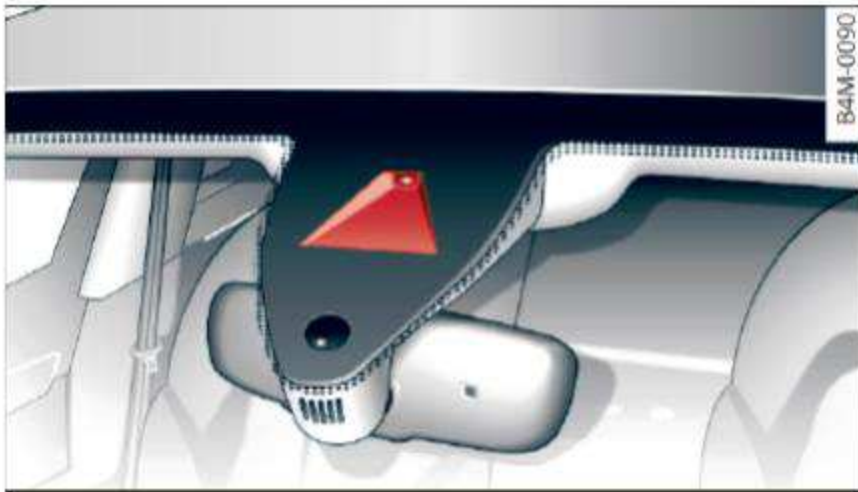

Fig. 115 Windshield: camera window for active lane assist

► Press the button to switch the system on and off ⇒ *fig. 114*. The indicator light in the instrument cluster turns on or off.

Analog instrument cluster	Audi virtual cockpit/head-up display*	Meaning on the corresponding side
Green line(s) (left/right) / \	Green line(s) (left/right) / \	Active lane assist is activated and ready to provide warnings.
-	Red line (left/right) / \	Active lane assist warns you before leaving a lane. In addition, the steering wheel vibrates lightly.
Yellow line(s) (left/right) / \	Yellow line(s) (left/right) / \	Active lane assist is activated, but is not ready to give warning

If the system is switched on but is not ready to provide warnings, one of the following could be the cause:

- There is no lane marker line.
- The relevant lane marker lines are not detected (for example, markings in a construction zone or because they are obstructed by snow, dirt, water or lighting).
- The vehicle speed is below the activation speed of approximately 40 mph (65 km/h).
- The lane is too narrow or too wide.
- The curve is too narrow.
- The driver's hands are not on the steering wheel.

**i Tips**

- Make sure the camera window ⇒ *fig. 115* is not covered by stickers or other objects. For information on cleaning, see ⇒ *page 344*.
- In certain markets: if the system is switched on, it will switch on automatically each time the ignition is switched on.

**Display in the instrument cluster**

Applies to: vehicles with Audi active lane assist



Fig. 116 Instrument cluster (multi-color display): active lane assist is switched on and ready to provide warnings

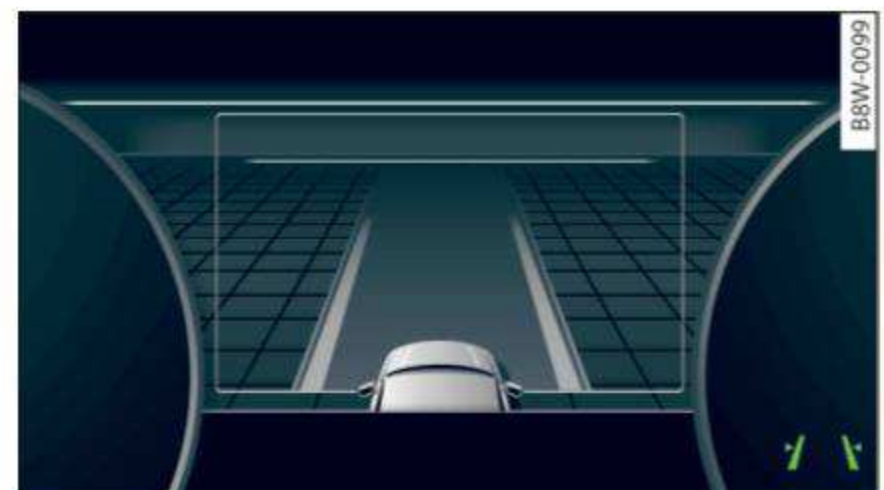

Fig. 117 Instrument cluster (monochrome display): active lane assist is switched on

You can open up the **Driver assistance** display for the active lane assist using the multifunction steering wheel buttons ⇒ *page 12*.

An additional indicator appears in the head-up display\*.

### Multi-Color Display

See ⇒ *fig. 116*.

Driver assistance display in the instrument cluster	Meaning on the corresponding side
Green line(s) (left or right)	Active lane assist is activated and ready to provide warnings.
Red line (left or right)	Active lane assist warns you before leaving a lane. In addition, the steering wheel vibrates lightly.
Gray line(s) (left or right)	Active lane assist is activated, but is not ready to give warning

### Monochrome display

See ⇒ *fig. 117*.

Driver assistance display in the instrument cluster	Meaning on the corresponding side
Light gray line(s) (left or right)	Active lane assist is activated and ready to provide warnings.
Blinking line(s) (left or right)	Active lane assist warns you before leaving a lane. In addition, the steering wheel vibrates lightly.
Dark gray line(s) (left or right)	Active lane assist is activated, but is not ready to give warning

### Messages in the instrument cluster display

If the active lane assist switches off automatically, the indicator light in the display turns off and one of the following messages appears:

 **Audi active lane assist: malfunction! See owner's manual**

Drive to an authorized Audi dealer or authorized Audi Service Facility immediately to have the malfunction corrected.

 **Audi active lane assist: currently unavailable. Camera view restricted due to surroundings. See owner's manual**

This message appears if the camera is unable to detect the lines. This could happen if:

- The camera field of view ⇒ *page 118, fig. 115* is dirty or covered in ice. Clean this area on the windshield ⇒ *page 344*.
- The camera field of view is fogged over. Wait until the fog has cleared before switching the active lane assist on again.
- The system has been unable to detect the lanes for an extended period of time due to road conditions. Switch active lane assist back on when the lines are more visible.

 **Audi active lane assist: currently unavailable. See owner's manual**

There is a temporary malfunction that may prevent the active lane assist from switching on. Try switching the active lane assist on again later.

 **Audi active lane assist: Please take over steering!**

This message appears if you are not steering by yourself. Active lane assist is activated, but is not ready to give warning

#### **WARNING**

Note that messages may be delayed or not displayed on vehicles with accessories mounted on the steering wheel, such as a steering wheel spinner knob. Always keep your hands on the steering wheel.

#### **Adjusting the steering time and vibration warning**

Applies to: vehicles with Audi active lane assist

*You can adjust individual active lane assist settings in the Infotainment system.*

- ▶ Select in the Infotainment system: **MENU** button > **Vehicle** > left control button > **Driver assistance** > **Audi active lane assist**.

### Steering time

**Early:** in this setting, the corrective steering happens continuously to help keep the vehicle in the center of the lane.

**Late:** in this setting, the system provides corrective steering just before a wheel goes over a detected lane marker line.

### Vibration warning

You can switch the additional vibration warning in the steering wheel on or off.

#### **WARNING**

With the vibration warning switched off, there will also be no visual warning in the instrument cluster display when crossing a lane marker line.

#### **Tips**

In certain markets: your settings are stored automatically and assigned to the remote control key in use.

## Audi side assist

### Description

Applies to: vehicles with Audi side assist

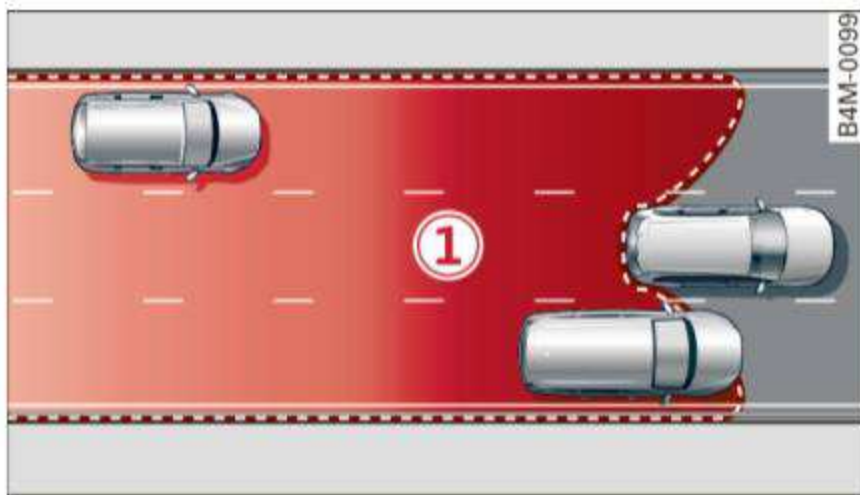

Fig. 118 Sensor detection range



Fig. 119 Display on the exterior mirror

Side assist (lane change assist) helps you monitor your blind spot and traffic behind your vehicle. Within the limits of the system, it warns you about vehicles that are coming closer or that are traveling with you within sensor range **1** ⇒ fig. 118. If a lane change is classified as critical, the display **2** in the exterior mirror turns on ⇒ fig. 119.

The display in the left exterior mirror provides assistance when making a lane change to the left, while the display in the right exterior mirror provides assistance when making a lane change to the right.

### Information stage

As long as you do not activate the turn signal, side assist *informs* you about vehicles that are detected and classified as critical. The display in the mirror turns on, but is dim.

The display remains dim in the information stage so that your view toward the front is not disturbed.

### Warning stage

If the display in a mirror blinks brightly when you activate a turn signal, side assist is *warning* you about detected vehicles that it has classified as critical. If this happens, check traffic by glancing in the exterior mirrors and over your shoulder ⇒  in *General information on page 122*.

Applies to: vehicles with active lane assist: the display in the mirror can also blink if you have not activated a turn signal: if you are approaching a detected lane marker line and it appears you will be leaving the lane, side assist will warn you ►

about detected vehicles that it has classified as critical.

### **i** Tips

You can adjust the brightness on of the display on the rearview mirror ⇒ [page 122](#).

### General information

Applies to: vehicles with Audi side assist

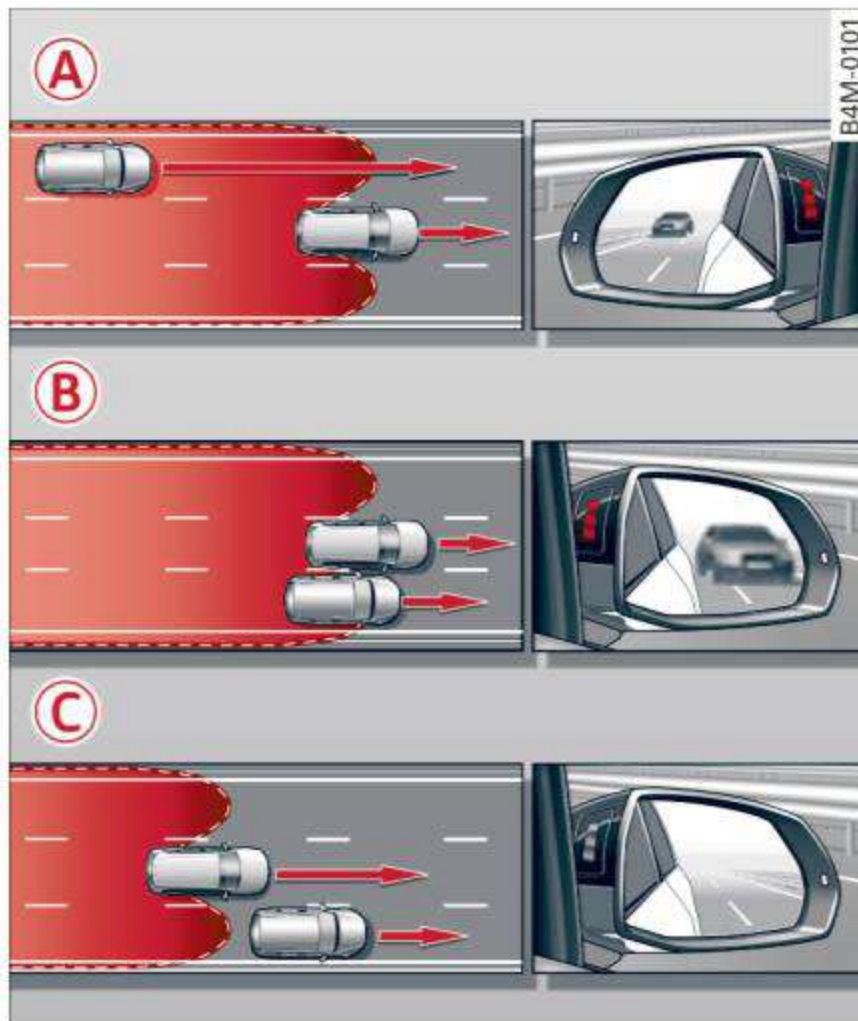

Fig. 120 Driving situations



Fig. 121 Rear of the vehicle: position of the sensors

Side assist functions at speeds above approximately 9 mph (15 km/h).

### **A** Vehicles that are approaching

In certain cases, a vehicle will be classified as critical for a lane change even if it is still somewhat far away. The faster a vehicle approaches,

the sooner the display in the exterior mirror will turn on.

### **B** Vehicles traveling with you

Vehicles traveling with you are indicated in the exterior mirror if they are classified as critical for a lane change. All vehicles detected by side assist are indicated by the time they enter your “blind spot”, at the latest.

### **C** Vehicles you are passing

If you slowly pass a vehicle that side assist has detected (the difference in speed between the vehicle and your vehicle is less than approximately 9 mph (15 km/h)), the display in the exterior mirror turns on as soon as the vehicle enters your blind spot.

The display will not turn on if you quickly pass a vehicle that side assist has detected (the difference in speed is greater than approximately 9 mph (15 km/h)).

### Functional limitations

The radar sensors are designed to detect the left and right adjacent lanes when the road lanes are the normal width. In some situations, the display in the exterior mirror may turn on even though there is no vehicle located in the area that is critical for a lane change. For example:

- If the lanes are narrow or if you are driving on the edge of your lane. If this is the case, the system may have detected a vehicle in another lane that is *not* adjacent to your current lane.
- If you are driving through a curve. Side assist may react to a vehicle that is in the same lane or one lane over from the adjacent lane.
- If side assist reacts to other objects (such as roadside structures like guard rails).
- In poor weather conditions. The side assist functions are limited.

Do not cover the radar sensors ⇒ [fig. 121](#) with stickers, deposits, bicycle wheels or other objects, because this will impair the function. Do not use side assist when towing a trailer. For information on cleaning, see ⇒ [page 344](#).

### **WARNING**

- Always pay attention to traffic and to the area around your vehicle. Side assist cannot replace a driver's attention. The driver alone is always responsible for lane changes and similar driving maneuvers.
- In some situations, the system may not function or its function may be limited. For example:
  - If vehicles are approaching or being left behind very quickly. The display may not turn on in time.
  - In poor weather conditions such as heavy rain, snow or heavy mist.
  - On very wide lanes, in tight curves, or if there is a rise in the road surface. Vehicles in the adjacent lane may not be detected because they are outside of the sensor range.

### **Note**

The sensors can be displaced by impacts or damage to the bumper, wheel housing and underbody. This can impair the system. Have an authorized Audi dealer or authorized Audi Service Facility check their function.

### **Tips**

- If the window glass in the driver's door or front passenger's door has been tinted, the display in the exterior mirror may be incorrect.
- For an explanation on conformity with the FCC regulations in the United States and the Industry Canada regulations, see [⇒ page 374](#).

### **Switching on/off**

Applies to: vehicles with Audi side assist

*The system can be switched on/off in the Infotainment system.*

- ▶ Select in the Infotainment system: **MENU** button > **Vehicle** > left control button > **Driver assistance** > **Audi side assist**. **Off** switches the system off.

If the system is activated, the displays in the exterior mirrors will turn on briefly when the ignition is switched on.

### **Tips**

When you switch side assist on or off, the exit warning system activates or deactivates [⇒ page 123](#).

### **Setting the display brightness**

Applies to: vehicles with Audi side assist

*The display brightness can be adjusted in the Infotainment system.*

- ▶ Select in the Infotainment system: **MENU** button > **Vehicle** > left control button > **Driver assistance** > **Audi side assist**.

The display brightness adjusts automatically to the brightness of the surroundings, both in the information and in the warning stage. In very dark or very bright surroundings, the automatic adjustment will set the display to the minimum or maximum level. In such cases, you may notice no change when adjusting the brightness, or the change may only be noticeable once the surroundings change.

Adjust the brightness to a level where the display in the information stage will not disrupt your view ahead. If you change the brightness, the display in the exterior mirror will briefly show the brightness level in the information stage. The brightness of the warning stage is linked to the brightness in the information stage and is adjusted along with the information stage.

### **Tips**

- The side assist functions are not active during the adjustment process.
- The exit warning indicators turn on during the adjustment process.
- Your settings are automatically stored and assigned to the remote control key being used.

## Exit warning

Applies to: vehicles with exit warning system

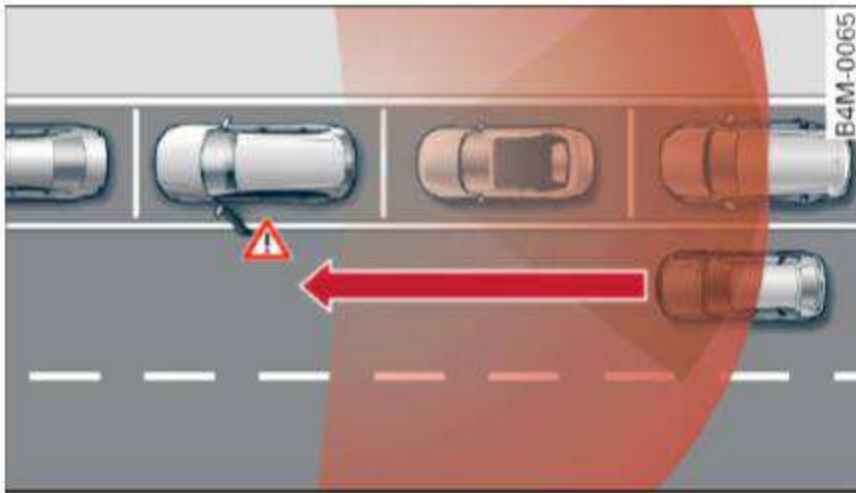

Fig. 122 Example display



Fig. 123 Door: warning light

When the vehicle is stationary, the exit warning system warns the passengers of a possible collision when opening the door. Within the limits of the system, the system monitors the areas behind and next to the vehicle using the radar sensors ⇒ *page 121, fig. 121*. Moving objects that are approaching from behind, such as cars, are detected ⇒ *fig. 122*.

If you open the door and a critical situation is detected, the door handle frame on the affected door will blink ⇒ *fig. 123* and the display in the outside mirror on the same side also appears. If the door is already open and another road user is detected and the situation is classified as critical, then the corresponding displays turn on.

### WARNING

- Always pay attention to traffic and to the area around your vehicle. The exit warning system does not replace the attention of the passengers. The vehicle passengers are always responsible for opening the doors and exiting the vehicle.

- The exit warning system can be available for up to approximately three minutes after unlocking the vehicle and opening the door as well as after switching off the ignition. Then the system switches off with a brief flashing of the displays.
- The exit warning system does not respond to people and cannot warn you about every type of approaching objects, such as cyclists. Always monitor the traffic as well as the vehicle's surroundings with direct eye contact.

### WARNING

The exit warning system is subject to limitations and cannot warn you before every impending collision:

- If the vehicle is too wide for the parking space and covered by the neighboring vehicles.
- Approaching objects or people such as cyclists or skateboarders may not be detected under certain circumstances.
- The system does not react to stationary objects.
- The view of the radar sensors may be impaired by leaves, snow, heavy spray or dirt. Clean the area in front of the sensors ⇒ *page 121, fig. 121*.

### Note

Also read the information in ⇒  *in General information on page 122*.

### Tips

- The exit warning system is switched on and off through the side assist ⇒ *page 122*. The exit warning indicators turn on during the adjustment process.
- The display brightness for the exit warning system cannot be adjusted.
- The system is not available when towing a trailer.

### Rear cross-traffic assist

Applies to: vehicles with rear cross-traffic assist

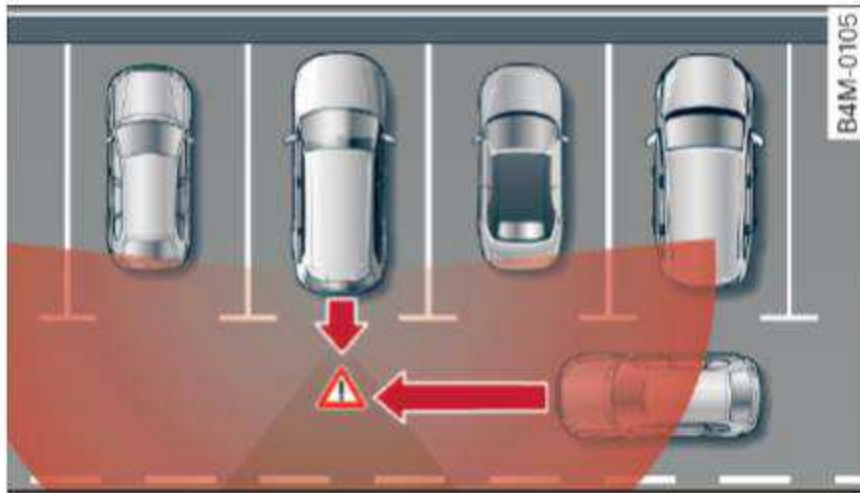

Fig. 124 Example display



Fig. 125 Infotainment system: rear cross-traffic assist display

### Activating rear cross-traffic assist

The rear cross-traffic assist is activated automatically if you turn on the parking aid ⇒ *page 130* or shift into reverse gear.

The rear cross-traffic assist can warn of a potential collision with approaching cross-traffic when driving in reverse at speeds up to approximately 9 mph (15 km/h). Within its limits, the system monitors the areas behind and next to the vehicle using the radar sensors when leaving a parking space ⇒ *page 121, fig. 121*. Moving objects that are approaching, such as cars, are detected ⇒ *fig. 124*.

If the system detects critical cross traffic when backing out of a parking space, it will react as follows:

- **Visual indicator:** an indicator appears in the Infotainment system display with a red arrow symbol. The arrow points in the direction from which the object is approaching ⇒ *fig. 125*.
- **Audible warning signal:** a continuous tone may sound as an additional indicator when driving in reverse.

- **Automatic brake activation:** a brief activation of the brakes may also warn you of a potential collision with an approaching object.

The audible warning signal and the automatic brake activation occur only when driving in reverse.

### ! WARNING

- The rear cross-traffic assist is an assist system and cannot prevent a collision by itself. The driver must always intervene. The driver is always responsible for braking at the correct time.
- Please note that the rear cross-traffic assist may activate the brakes unexpectedly. Secure any cargo that you are transporting to reduce the risk of damage or injury.
- Automatic braking cannot be triggered again within 20 seconds after an automatic brake activation.
- If there is an acoustic warning signal from the rear cross-traffic assist, then the parking system may not warn you of detected obstacles under certain circumstances.
- The view of the radar sensors may be impaired by leaves, snow, heavy spray or dirt. Clean the area in front of the sensors ⇒ *page 121, fig. 121*.

### ! WARNING

- The rear cross-traffic assist will not provide alerts if your vehicle is pulled too far into the parking space so that it is hidden by adjacent vehicles.
- The rear cross-traffic assist will not provide alerts about people and cannot warn you about every type of approaching objects, such as cyclists. Always monitor the traffic as well as the vehicle's surroundings with direct eye contact.
- The rear cross-traffic assist will not provide alerts if the vehicle is in a parallel parking space or an angled parking space.

### ! Note

Also read the information in ⇒ **!** in *General information on page 122*.

## Tips

- You can cancel the automatic brake activation with increasing braking force if you apply the brakes yourself or accelerate considerably.
- In some situations, rear cross-traffic assist may warn you even if there is no cross traffic in a critical area, for example when backing into a parking space or maneuvering.
- The rear cross-traffic assist also switches off when you switch off the ESC.
- The system is not available when towing a trailer.

## Messages

Applies to: vehicles with Audi side assist

A message appears in the instrument cluster display if the side assist switches off automatically.

 **Audi side assist: malfunction! Please contact Service**

 **Audi side assist and exit warning: malfunction! Please contact Service**

The system cannot guarantee that it will detect vehicles correctly and it has switched off. The sensors have been moved or are faulty. Have the system checked by an authorized Audi dealer or authorized Audi Service Facility soon.

 **Audi side assist: currently unavailable. Sensor vision restricted due to surroundings. See owner's manual**

 **Audi side assist and exit warning: currently unavailable. Sensor vision restricted due to surroundings**

The radar sensor vision is impaired. The area in front of the sensors must not be covered by bike racks, stickers, leaves, snow or any other objects. Clean the area in front of the sensors, if necessary ⇒ *page 121, fig. 121.*

 **Audi side assist: currently unavailable. See owner's manual**

 **Audi side assist and exit warning: currently unavailable. See owner's manual**

Side assist cannot be switched on at this time because there is a malfunction (for example, the battery charge level may be too low).

 **Audi side assist: unavailable in towing mode**

 **Audi side assist and exit warning: currently unavailable. Towing mode**

Side assist switches off automatically when the electrical connector in the factory-installed trailer hitch is connected. There is no guarantee the system will switch off when using a retrofitted trailer hitch. Do not use side assist and the exit warning when towing a trailer.

 **Rear parking aid: obstacle detection restricted**

The rear cross-traffic assist is not available. Either the ESC is switched off, or the radar sensors may be covered by a bike rack, stickers, leaves, snow or other objects. Switch the ESC on, or clean the area in front of the sensors if necessary ⇒ *page 121, fig. 121.* If this message continues to be displayed, drive immediately to an authorized Audi dealer or authorized Audi Service Facility to have the malfunction repaired.

## Audi drive select

### Introduction

Applies to: vehicles with Audi drive select

Drive select makes it possible to experience different types of vehicle settings in one vehicle. You can select the driving modes **Offroad\*** or **Lift / Offroad\***, **Allroad\***, **Comfort**, **Auto** and **Dynamic** in the Infotainment system, for example to switch from a sporty to a comfortable driving mode. In the **Individual** mode, the settings can be adjusted to your personal preferences. This makes it possible to combine settings such as a sporty engine setting with light steering.

### Description

Applies to: vehicles with Audi drive select

The following systems, among other things, are influenced by drive select: ►

### Engine and automatic transmission

Depending on the mode, the engine and automatic transmission respond more quickly or in a more balanced manner to accelerator pedal movements. In the sporty **Dynamic** mode, the transmission shifts at higher speed ranges.

### Air suspension\*

The air suspension\* is an electronically-controlled air suspension and damping system. The adjustment depends on the driving mode selected, steering movements, the driver's braking and acceleration, and as the road surface, vehicle speed and load. The vehicle ground clearance depends on the mode selected and the speed.

The ground clearance increases significantly when the vehicle is in the **Allroad** mode. At speeds from approximately 50 mph (80 km/h) to 75 mph (120 km/h), the ground clearance reduces in stages. When the speed decreases, the ground clearance increases again automatically. The ground clearance is the lowest in **Dynamic** mode.

### Suspension control\*

The suspension control\* uses sensors to record information regarding steering movements, braking and acceleration operations by the driver, road surface, driving speed, and load. This makes it possible to adapt damping to the driving situation nearly in real time. With drive select, you can adjust the suspension control to be sporty (**Dynamic**), comfortable (**Comfort**) or balanced (**Auto**).

### Steering

The power steering adapts. Indirect steering that moves easily as in **Comfort** mode is especially suited to long drives on highways. The **Dynamic** mode provides sporty, direct steering.

The following applies to vehicles with dynamic steering\*: the steering ratio changes based on vehicle speed in order to maintain optimum steering effort for the driver at all times. This sets the steering to be less sensitive at higher speeds in order to provide improved vehicle control. At reduced speeds, steering is more direct in

order to keep the steering effort as minimal as possible when the driver is maneuvering the vehicle. At low and average speeds, dynamic steering\* additionally provides more responsive steering performance.

### Sport differential\*

As a component of the all wheel drive system (quattro) ⇒ *page 144*, the sport differential distributes the driving power to the rear axle depending on the situation. The distribution of power varies depending on the selected mode from moderate (**Comfort**) to sporty (**Dynamic**). The goal is a high level of agility and ability to accelerate on curves. The vehicle is very responsive to steering.

### Adaptive cruise control (ACC)\*

The behavior when accelerating can be adjusted from comfortable to sporty, depending on the drive select mode. Adaptive cruise control also responds to the driving behavior of the vehicle ahead in a more conservative or sporty manner.

### Engine sound\*

The engine sound adapts to the current mode and can be subtle to sporty.

#### Note

Applies to: vehicles with air suspension

- Make sure there is enough clearance above and below the vehicle when parking. The height of the vehicle (ground clearance) can change once it is parked due to temperature fluctuations, changes to the load conditions and changes to the driving modes.
- When transporting the vehicle on a car carrier, train, ship or by other means, only tie the vehicle down at the running surface of the tires, which is the outer circumference. Securing the vehicle at the axle components, suspension struts or towing eyes is not permitted because the pressure in the air suspension struts can change during transport. The vehicle may not be secured sufficiently if this happens.

**i Tips**

The "S" selector lever position automatically engages when the **Dynamic** mode is selected.

**Selecting the driving mode**

Applies to: vehicles with Audi drive select

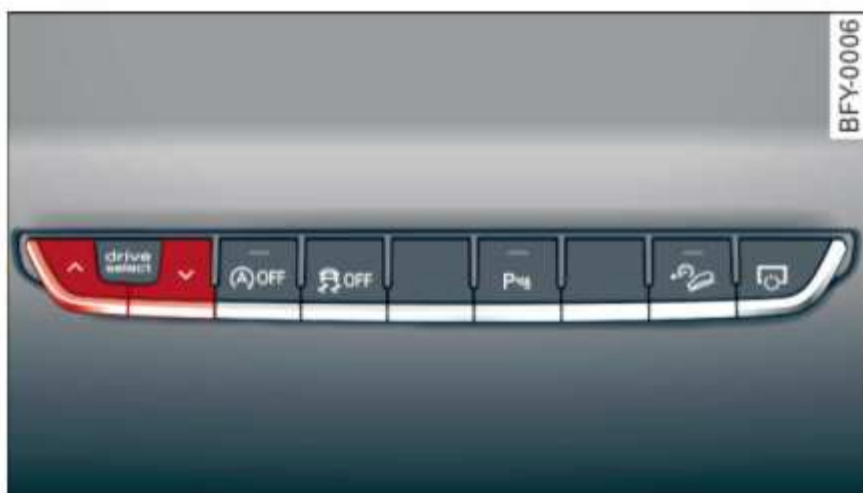

Fig. 126 Center console: controls for drive select

- ▶ Press the left or right arrow key ⇒ *fig. 126* until the desired mode appears in the instrument cluster/Infotainment system display. Or
- ▶ Select in the Infotainment system: **MENU** button > **Vehicle** > **Audi drive select**.
- ▶ Select and confirm the desired setting.

You can change the driving mode when the vehicle is stationary or while driving. If traffic per-

mits, after changing modes, briefly take your foot off the accelerator pedal so that the recently selected mode is also activated for the engine.

**Offroad\*** or **Lift / Offroad\*** - activates offroad functions to support driving on rough terrain. The engine, transmission and steering adjust and the Start/Stop system\* switches off. Applies to air suspension\*: the vehicle also lifts for passing over obstacles to maintain maximum ground clearance.

**Allroad\*** - only for air suspension\*: the vehicle lifts to maintain higher ground clearance for difficult stretches of road.

**Comfort** - provides a comfort-oriented vehicle setup and is suited for long drives on highways.

**Auto** - provides an overall comfortable yet dynamic driving feel and is suited for everyday use.

**Dynamic** - gives the driver a sporty driving feel and is suited to a sporty driving style.

**Individual** - ⇒ *page 127*.

**! WARNING**

Pay attention to traffic when operating the drive select to reduce the risk of an accident.

**Adjusting the Individual mode**

Applies to: vehicles with Audi drive select

*You can adjust the vehicle settings to your personal preferences.*

- ▶ Select in the Infotainment system: **MENU** button > **Vehicle** > **Audi drive select** > **Individual** > right control button.

After you have closed the settings, you will automatically drive in the **Individual** mode.

The equipment in your vehicle will determine which settings you can adjust. The following table gives an overview of the characteristics.

Systems	comfort	auto	dynamic
Engine/transmission	balanced	balanced	sporty
Air suspension*	comfortable	balanced	sporty
Steering	comfortable	balanced	sporty
Dynamic steering*	comfortable/indirect	balanced/direct	sporty/direct
Suspension control*	comfortable	balanced	sporty
Sport differential*	Off	balanced	sporty

Systems	comfort	auto	dynamic
Engine sound*	subtle	subtle/sporty <sup>a)</sup>	sporty
ACC*	comfortable	balanced	sporty

a) Subtle in the selector lever position "D" and sporty in "S".

### **i** Tips

Your settings are automatically saved in **Individual** mode.

### Raising/lowering the vehicle

Applies to: vehicles with air suspension

- ▶ Press the left or right arrow key ⇒ *page 127, fig. 126* until the desired mode appears in the instrument cluster/Infotainment system display. Or
- ▶ Select in the Infotainment system: **MENU** button > **Vehicle** > **Audi drive select**.
- ▶ Select and confirm the desired setting.

### **!** Note

The **Lift / Offroad** mode switches to **Allroad** mode when driving above approximately 20 mph (30 km/h) and the vehicle automatically lowers again. These modes may only be used on a temporary basis and are not intended for continuous driving.

### **i** Tips

- The filled-in boxes in the Infotainment system represent the current vehicle level. If the segment is white or blinking, then the vehicle is lifting or lowering. If only the bottom segment is filled in, then the vehicle is at the lowest level (lowest ground clearance). If all the segments are filled in, then the vehicle is at the highest level (highest ground clearance).
- The target level is highlighted with a *red* frame while the vehicle is lifting or lowering. The frame is then hidden when the vehicle reaches the target level.
- The vehicle lifts up to the highest level when you select **Lift / Offroad**. Select another mode to lower the vehicle again.

### Rear lowering

Applies to: vehicles with air suspension

*The rear of the vehicle can be lowered to make loading and unloading easier.*



Fig. 127 Section of luggage compartment: rear lowering button

Requirement: all vehicle doors must be closed.

- ▶ Open the luggage compartment lid.
- ▶ Press the lower section of the button ⇒ *fig. 127 ②*. The rear of the vehicle lowers.
- ▶ Press the upper section of the button **①**. The rear of the vehicle raises again.

The rear lowering automatically deactivates when you select another mode or when the vehicle speed exceeds approximately 2 mph (2 km/h).

The LED in the button turns on while the vehicle is lowering. When the loading level has been reached, the LED stays on as long as the rear of the vehicle is lowered. The LED turns off when the vehicle returns to the original level.

### **!** Note

- Before the rear lowering ends, make sure there is enough clearance above the vehicle and the luggage compartment lid, if it is open.
- Do not park the vehicle in a lowered loading level.

 **Tips**

- The vehicle will not lower if one of the vehicle doors is open or when the ignition is switched off and the compressed air reservoir is empty. The button LED blinks three times.
- If the compressed air reservoir is empty, it is refilled while driving at speeds above 25 mph (40 km/h).

**Messages**

Applies to: vehicles with air suspension

 **Air suspension: vehicle currently too high. Controlling level...**

 **Air suspension: vehicle currently too low. Controlling level...**

The message turns off when the level control process is complete.

## Parking aid

### General information

Applies to: vehicles with a rear parking system/parking system plus/rearview camera/peripheral cameras

Depending on your vehicle's equipment, various parking aids will help you when parking and maneuvering.

The **rear parking system** is an audible parking aid that warns you of obstacles *behind* the vehicle  
⇒ *page 131*.

The **parking system plus** assists you when parking by audibly and visually indicating objects detected *in front of* and *behind* the vehicle  
⇒ *page 131*.

The **rearview camera** shows the area behind the vehicle in the Infotainment system display. The lines in the rearview camera image help you to park or maneuver ⇒ *page 133*.

The **peripheral cameras** give various views to help you when parking or maneuvering  
⇒ *page 135*. The parking system plus functions are also available ⇒ *page 131*.

#### WARNING

- Always look for traffic and check the area around your vehicle by looking at it directly as well. The parking system cannot replace the driver's attention. The driver is always responsible when entering or leaving a parking space and during similar maneuvers.
- Please note that some surfaces, such as clothing, are not detected by the system.
- Sensors and cameras have blind spots in which people and objects cannot be detected. Be especially cautious of small children and animals.
- Always keep your eyes on the vehicle's surroundings, using the rearview mirror as well.
- The sensors can be displaced by impacts or damage to the radiator grille, bumper, wheel housing and the underbody. The parking system may be impaired as a result. Have an authorized Audi dealer or author-

ized Audi Service Facility check their function.

#### Note

- Some objects are not detected or displayed by the system under certain circumstances:
  - objects such as barrier chains, trailer draw bars, vertical poles or fences
  - objects above the sensors such as wall extensions
  - objects with certain surfaces or structures such as chain link fences or powder snow
- If you continue driving closer to a low object, it may disappear from the sensor range. Note that you will no longer be warned about this obstacle.
- Keep enough distance from the curb to reduce the risk of damage to the rims.

#### Tips

- The system may provide a warning even though there are no obstacles in the coverage area in some situations, such as:
  - certain road surfaces or when there is tall grass
  - external ultrasonic sources such as from cleaning vehicles
  - in heavy rain, snow, or thick vehicle exhaust
- We recommend that you practice parking in a traffic-free location or parking lot to become familiar with the system. When doing this, there should be good light and weather conditions.
- You can change the volume of the signals and the display ⇒ *page 138*.
- Please refer to the instructions for towing a trailer located in ⇒ *page 139*.
- What appears in the infotainment display is somewhat time-delayed.
- The sensors must be kept clean and free of snow and ice for the parking aid to operate.
- The rearview camera is cleaned when cleaning the rear window ⇒ *page 51*.

## Rear parking system

### Description

Applies to: vehicles with rear parking aid

The rear parking system is an audible parking aid.

### Description

There is a sensor in the rear bumper cover. If these detect an obstacle, audible signals warn you.

Make sure the sensors are not covered by stickers, deposits or any other obstructions as it may impair the function of the system. For information on cleaning, see ⇒ page 344.

The range at which the sensors begin to measure is approximately:

rear	side	3 ft (0.90 m)
	center	5.2 ft (1.60 m)

The closer you get to the obstacle, the shorter the interval between the audible signals. A continuous tone sounds when the obstacle is less than approximately 1 foot (0.30 meters) away. Do not continue backing up ⇒ ⚠ in General information on page 130, ⇒ ⚠ in General information on page 130!

If the distance to an obstacle remains constant, the volume of the distance warning gradually lowers after a few seconds until it is muted (this is not apply in the continuous tone range). If the obstacle becomes closer than it was before the sound was muted, the tone will sound again. If the obstacle is farther away than it was before the sound was muted, no tone will sound. Pay attention to the vehicle's surroundings when you start to drive.

### Switching on automatically

The system switches on automatically when reverse gear is engaged while the engine is running. A brief confirmation tone will sound.

## Parking system plus

### Description

Applies to: vehicles with parking system plus

Parking system plus provides audio and visual signals when parking.



Fig. 128 Illustration:

Sensors are located in the front and rear bumpers. If these detect an obstacle, audible and visual signals warn you.

Make sure the sensors are not covered by stickers, deposits or any other obstructions as it may impair the function of the system. For information on cleaning, see ⇒ page 344.

The display field begins approximately at:

(A)	4 ft (1.20 m)
(B)	3 ft (0.90 m)
(C)	5.2 ft (1.60 m)
(D)	3 ft (0.90 m)

The closer you get to the obstacle, the shorter the interval between the audible signals. A continuous tone sounds when the obstacle is less than approximately 1 foot (0.30 meters) away. Do not continue driving forward or in reverse ⇒ ⚠ in General information on page 130, ⇒ ⚠ in General information on page 130!

If the distance to an obstacle remains constant, the volume of the distance warning gradually lowers after a few seconds until it is muted (this is not apply in the continuous tone range). If the obstacle becomes closer than it was before the sound was muted, the tone will sound again. If the obstacle is farther away than it was before

the sound was muted, no tone will sound. Pay attention to the vehicle's surroundings when you start to drive.

### Switching on/off

Applies to: vehicles with parking system plus

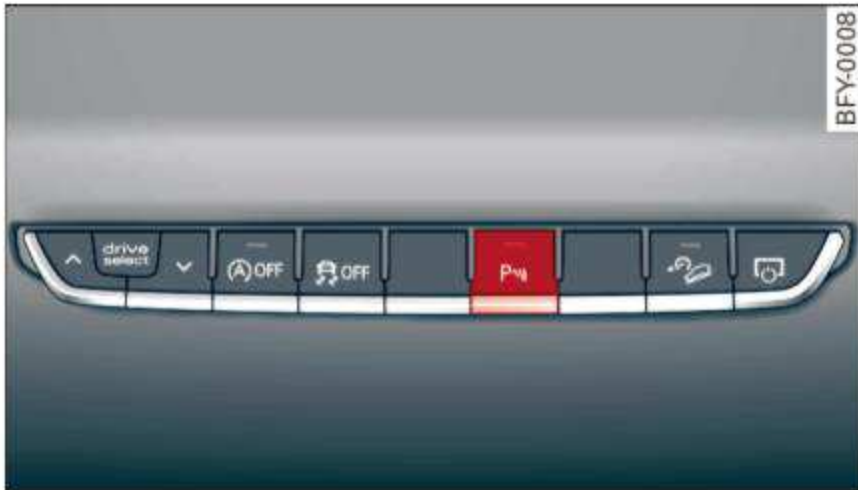

Fig. 129 Center console: parking aid button



Fig. 130 Infotainment system: visual distance display

### Switching on/off

Requirement: the vehicle speed must be under approximately 6 mph (10 km/h).

- ▶ Press the **P** button in the center console. A short confirmation tone sounds and the LED in the button turns on.

### Switching on automatically

The system switches on automatically when reverse gear is engaged while the engine is running. A brief confirmation tone will sound.

If the vehicle approaches an obstacle at speeds under approximately 6 mph (10 km/h), the parking aid will switch on automatically. Audible signals will sound once the obstacle is within the sensor detection area.

If **Activate automatically** is switched on in the Infotainment system and if the vehicle approaches an obstacle at speeds under approximately 6 mph (10 km/h), the parking aid will

switch on automatically. Audible signals will sound once the obstacle is within the sensor detection area.

### Switching off automatically

The distance indicator for the parking system plus switches off automatically when driving forward faster than 6 mph (10 km/h).

### Segments in the visual display

The segments in front of and behind the vehicle ⇒ *fig. 130* help you to determine the distance between your vehicle and an obstacle. The red lines\* mark the expected direction of travel according to the steering angle. A white segment indicates an identified obstacle that is outside of the vehicle's path. Red segments show identified obstacles that are in your vehicle's path. As your vehicle comes closer to the obstacle, the segments move closer to the vehicle. The collision area has been reached when the next to last segment is displayed. Obstacles in the collision area, including those outside of the vehicle's path, are shown in red. Do not continue driving forward or in reverse ⇒ ⚠ in *General information on page 130*, ⇒ ⚠ in *General information on page 130*!

### **i** Tips

- If you press the **P** button to switch the parking aid off, it can only be reactivated automatically when one of the following conditions is met:
- The vehicle speed exceeds 6 mph (10 km/h).
  - The ignition is switched off and back on again.
  - The parking brake is set and then released.
  - The "P" selector lever position is engaged and released again.

## Rearview camera

### Introduction

Applies to: vehicles with rearview camera

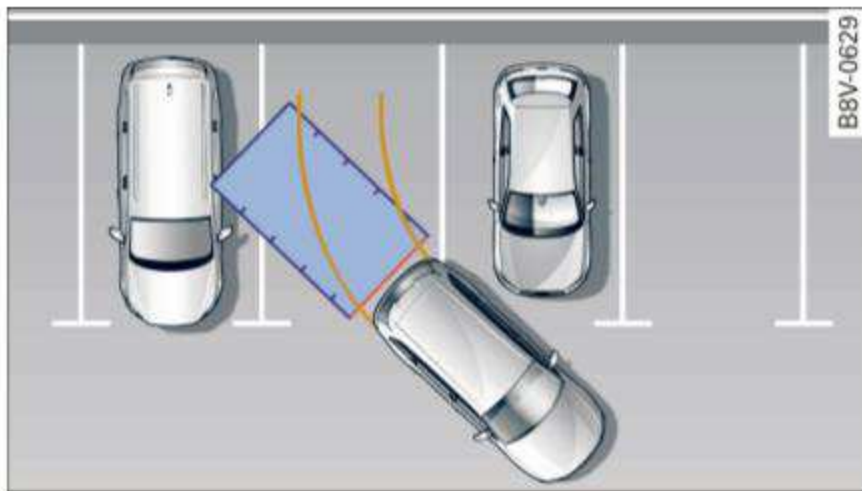

Fig. 131 Diagram: lines to aid in parking

The rearview camera helps you to park or maneuver using the orientation lines.

### General information

Applies to: vehicles with rearview camera

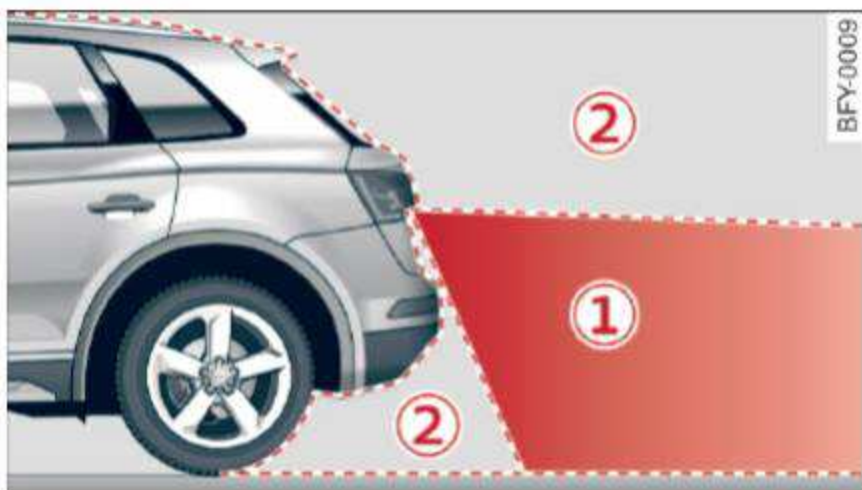

Fig. 132 Area covered ① and area not covered ② by the rearview camera.



Fig. 133 Luggage compartment lid: location of the rearview camera

The rearview camera is located above the rear license plate bracket. Make sure that the lens for the rearview camera ⇒ fig. 133 is not covered by deposits or any other obstructions because this

can impair the function of the rearview camera. For information on cleaning, see ⇒ page 344.

The rearview camera coverage area includes ① ⇒ fig. 132. Only this area is shown in the Infotainment display. Objects that are in area ②, which is not covered, are not displayed.

### ! WARNING

- Always read and follow the applicable warnings ⇒ ! in General information on page 130.
- If the position and the installation angle of the rearview camera was changed, for example after a collision, do not continue to use the system for safety reasons. Have it checked by an authorized Audi dealer or authorized Audi Service Facility.
- Only use the rearview camera to assist you if it shows a good, clear picture. For example, the image may be affected by the sun shining into the lens, dirt on the lens, or if there is a malfunction.
- Use the rearview camera only if the luggage compartment lid is completely closed. Make sure any objects you may have mounted on the luggage compartment lid do not block the rearview camera.
- The camera lens enlarges and distorts the field of vision. The object appears both altered and inaccurate on the screen.
- In certain situations, people or objects in the display appear closer or farther away:
  - For objects that do not touch the ground, such as the bumper of a parked vehicle, a trailer hitch or the rear of a truck. Do not use the orientation lines in this case.
  - If driven from a level surface onto an incline, or a downward slope.
  - If driven toward protruding objects.
  - If the vehicle is carrying too much load in the rear.
- Applies to: vehicles with air suspension: the accuracy of the orientation lines and blue surfaces decreases when the vehicle is raised/lowered ⇒ page 125.

**! Note**

- Always read and follow the applicable warnings ⇒ **!** in *General information on page 130*.
- The orange-colored orientation lines in the Infotainment display show the vehicle path based on the steering wheel angle. The front of the vehicle swings out more than the rear of the vehicle. Maintain plenty of distance so that an exterior mirror or a corner of the vehicle does not collide with any obstacles.

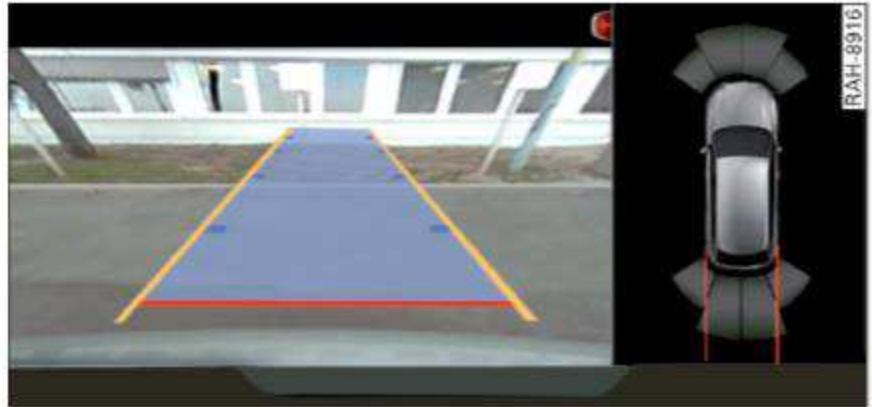

Fig. 135 Infotainment system: aligning the vehicle

- ▶ Turn the Infotainment system on and shift into reverse gear.
- ▶ The orange orientation lines ① show the vehicle's direction of travel. Turn the steering wheel until the orange orientation lines appear in the parking space ⇒ *fig. 134*. Use the markings ② to help you estimate the distance to an obstacle. Each marking represents approximately 3 ft (1 m). The blue area represents an extension of the vehicle's outline by approximately 16 ft (5 meters) to the rear.
- ▶ While driving in reverse gear, adjust the steering wheel angle to fit the parking space using the orange orientation lines for assistance ⇒ **!** in *General information on page 133*, ⇒ **!** in *General information on page 134*. ③ represents the rear bumper. At the very latest, stop the vehicle when the red orientation line ④ borders an object.

**Switching on/off**

Applies to: vehicles with rearview camera

**Switching on/off**

Requirement: the vehicle speed must be under approximately 6 mph (10 km/h).

- ▶ Press the **P** button in the center console ⇒ *page 132, fig. 129*. A short confirmation tone sounds and the LED in the button turns on.

**Switching on automatically**

The system switches on automatically when reverse gear is engaged while the engine is running. A brief confirmation tone will sound.

**Switching off automatically**

The system switches off automatically when driving forward faster than 6 mph (10 km/h).

**Perpendicular parking**

Applies to: vehicles with rearview camera

*This view may be used when parking in a garage or in a parking space.*

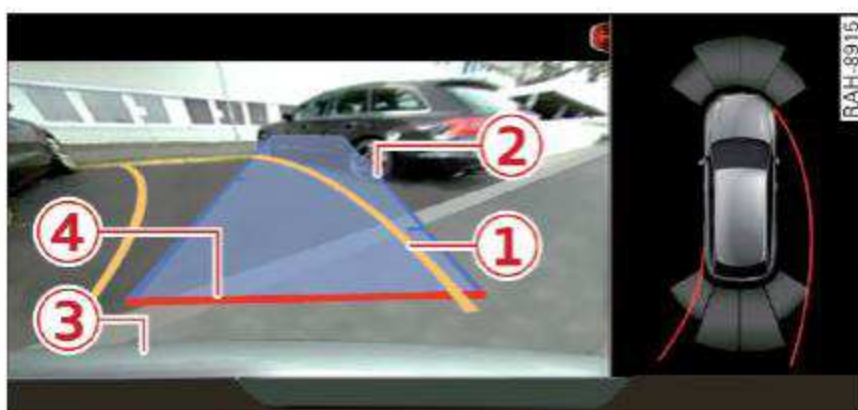

Fig. 134 Infotainment system: aiming at a parking space

**Trailer view**

Applies to: vehicles with rearview camera/peripheral cameras and trailer hitch

*This view assists you in positioning the vehicle in front of a trailer.*

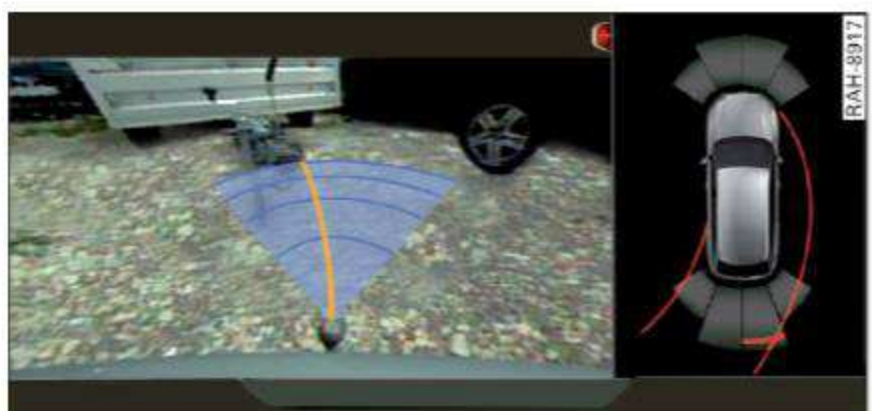

Fig. 136 Infotainment system: trailer view

Requirement: **Trailer view** must be selected ⇒ *page 138*.

- ▶ Now you can position your vehicle in front of the trailer ⇒ ⚠ in *General information on page 135*, ⇒ ⚠ in *General information on page 135*. The orange orientation line indicates the expected path toward the trailer hitch. Use the blue lines to help you estimate the distance to the trailer hitch.

## Peripheral cameras

### Introduction

Applies to: vehicles with peripheral cameras

With this equipment, the parking system plus\* ⇒ *page 131* is supplemented with various peripheral cameras. The four cameras give you the following views: area around the vehicle, front corner view and rear corner view, view in front of the vehicle and behind the vehicle.

### General information

Applies to: vehicles with peripheral cameras

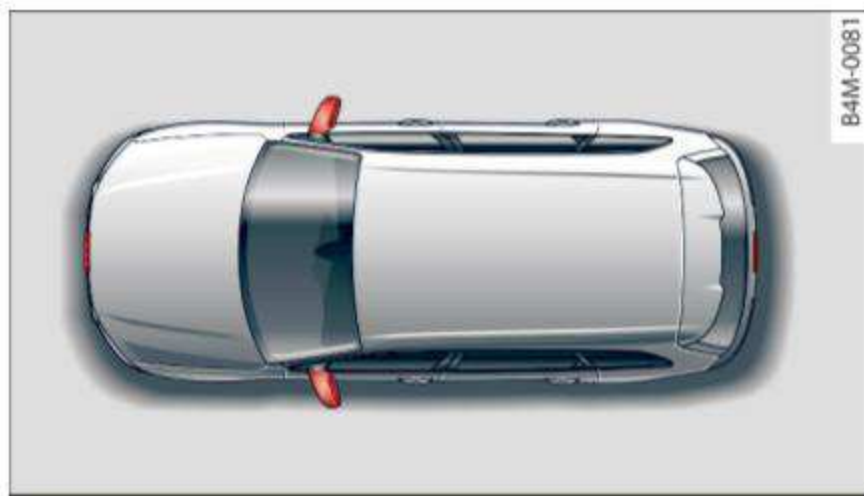

Fig. 137 Location of peripheral cameras

The four peripheral cameras are located in the radiator grille, in the luggage compartment lid and on both exterior mirrors ⇒ *fig. 137*. Make sure that the lenses are not covered by deposits or any other obstructions as this may impair the system. For information on cleaning, see ⇒ *page 344*.

Black corners are shown in the vehicle silhouette when in **Surroundings** mode. Objects in these areas are outside of the camera's field of view and are not detected.

### ⚠ WARNING

- Always read and follow the applicable warnings ⇒ ⚠ in *General information on page 130*.

- If the position or the installation angle of a camera was changed, for example after a collision, do not continue to use the system for safety reasons. Have it checked by an authorized Audi dealer or authorized Audi Service Facility.
- Keep in mind that the image in the display is incorrect if the exterior mirror housing has been moved out of place.
- Use the **Rear** mode and the **Corner view (rear)** mode only when the luggage compartment lid is completely closed. Otherwise the image in the display will be incorrect.
- The area around the vehicle is shown using the camera images. The vehicle image is shown by the system. Objects and obstacles above the camera are not displayed.
- Camera lenses enlarge and distort the field of vision. The objects appear both altered and inaccurate on the screen.
- Applies to: vehicles with air suspension: the accuracy of the orientation lines and blue surfaces decreases when the vehicle is raised/lowered ⇒ *page 125*.

### ⚠ Note

- Always read and follow the applicable warnings ⇒ ⚠ in *General information on page 130*.
- The Infotainment display shows the direction in which the rear of the vehicle is traveling based on the steering wheel angle. The front of the vehicle swings out more than the rear of the vehicle. Maintain plenty of distance so that an exterior mirror or a corner of the vehicle does not collide with any obstacles.

### i Tips

If the symbol appears in the display and the respective display area is grayed out, then the power exterior mirrors were folded in or the driver's door/front passenger's door/luggage compartment lid was opened.

### Switching on/off

Applies to: vehicles with peripheral cameras



Fig. 138 Infotainment system: select the mode

### Switching on/off

Requirement: the vehicle speed must be under approximately 6 mph (10 km/h).

- ▶ Press the **P** button in the center console ⇒ page 132, fig. 129. A short confirmation tone sounds and the LED in the button turns on.

### Switching on automatically

The system switches on automatically when reverse gear is engaged while the engine is running. A brief confirmation tone will sound.

### Switching off automatically

The system switches off automatically when driving forward faster than 6 mph (10 km/h).

### Selecting the mode

- ▶ Turn the control knob to the symbol for the desired mode **A** through **E** ⇒ fig. 138 and press the control knob.

You may select from the following modes:

- A** - Corner view (front) ⇒ page 136
- B** - Front ⇒ page 136
- C** - Area ⇒ page 137
- D** - Rear ⇒ page 137
- E** - Corner view (rear) ⇒ page 136

You can also switch to trailer view ⇒ page 134.

### Corner view (front)/corner view (rear)

Applies to: vehicles with peripheral cameras



Fig. 139 Infotainment system: Corner view (front)



Fig. 140 Infotainment system: Corner view (rear)

This view can assist you for example, when you are exiting from an area with poor visibility. The area at the front and rear sides of the vehicles is displayed.

- ▶ To show the side view toward the front, select the symbol **A** ⇒ fig. 139 with the control knob and press the control knob.
- ▶ To show the side view toward the rear, select the symbol **E** ⇒ fig. 140 with the control knob and press the control knob.

### Front

Applies to: vehicles with peripheral cameras



Fig. 141 Infotainment system: front mode

This view assists you for example, in using the full maneuvering range in front of the vehicle. The area in front of the vehicle is displayed. The vehicle surroundings are shown in the right area ▶

of the display. You can switch between the optical display and camera image ⇒ *page 138*.

- ▶ Select the symbol **(B)** with the control knob. The orange-colored orientation lines denote the projected direction of travel. Stop the vehicle when the red orientation line\* borders an object ⇒ **(A)** in *General information on page 135*.

### Surroundings

Applies to: vehicles with peripheral cameras



Fig. 142 Infotainment system: Surroundings mode

This view is ideal for maneuvering. The area around the vehicle is shown using the camera images. The vehicle image is shown by the system.

- ▶ Select the symbol **(C)** with the control knob and press the control knob.

### Rear

Applies to: vehicles with peripheral cameras



Fig. 143 Infotainment system: rear mode

This view assists you for example, in using the full maneuvering range behind the vehicle. The area behind the vehicle is displayed. The vehicle surroundings are shown in the right area of the display. You can switch between the optical display and camera image ⇒ *page 138*.

- ▶ Select the symbol **(D)** with the control knob.

### Perpendicular parking

Applies to: vehicles with peripheral cameras

This view may be used when parking in a garage or in a parking space.



Fig. 144 Infotainment system: aiming at a parking space



Fig. 145 Infotainment system: aligning the vehicle

- ▶ Turn the Infotainment system on and shift into reverse gear.
- ▶ The orange orientation lines **(1)** show the vehicle's direction of travel. Turn the steering wheel until the orange orientation lines appear in the parking space ⇒ *fig. 144*. Use the markings **(2)** to help you estimate the distance to an obstacle. Each marking represents approximately 3 ft (1 m). The blue area represents an extension of the vehicle's outline by approximately 16 ft (5 meters) to the rear.
- ▶ While driving in reverse gear, adjust the steering wheel angle to fit the parking space using the orange orientation lines for assistance ⇒ **(A)** in *General information on page 135*, ⇒ **(I)** in *General information on page 135*. **(3)** represents the rear bumper. You should stop reversing at the latest when the red orientation line **(4)** borders an object ⇒ **(A)** in *General information on page 133*.

# Adjusting the parking aid

Applies to: vehicles with a rear parking system/parking system plus/rearview camera/peripheral cameras

The functions are adjusted in the Infotainment system.

- ▶ Select in the Infotainment system: **MENU** button > **Vehicle** > left control button > **Driver assistance** > **Parking aid**. Or
- ▶ When the parking aid is active, select in the Infotainment system: right control button\*.

**End system\*** - stop the parking aid

**Activate automatically\*** - switch automatic activation on/off

**Front volume\*** - volume for the front area

**Rear volume** - volume for the rear area

**Entertainment fader** - the volume of the audio/video source is lowered when the parking system is turned on.

The new value is given briefly during the adjustment.

**View\*** - switch between an optical display (**Graphic**) and camera image (**Camera**) in the right section of the display.

**Trailer view\*** - show trailer view

**\*Auto. front/rear camera change\*** - the view behind the vehicle (**Rear** mode) is displayed automatically when you shift into reverse gear. The view in front of the vehicle (**Front** mode) is displayed automatically when you shift into the forward gears. When first activating in a forward gear with the **P** button, the front side view is displayed (**Corner view (front)** mode).

If you do not set the ✓, the view behind the vehicle (**Rear** mode) is always displayed and it does not switch to the **Front** mode when a forward gear is selected.

### Tips

- Several menus can be accessed with the right control button only when the parking aid is active.

- The settings for volume and automatic activation\* are stored automatically and assigned to the remote control key in use.

## Error messages

Applies to: vehicles with a rear parking system/parking system plus/rearview camera/peripheral cameras

 **Rear parking aid: malfunction! Obstacles cannot be detected**

 **Front parking aid: malfunction! Obstacles cannot be detected**

 **Parking aid: malfunction! Obstacles cannot be detected**

When one of these messages appears, there is a system malfunction. The LED in the **P** button also blinks when switching it on. The relevant message only appears again when you manually activate the parking aid with the button.

 **Rear parking aid: obstacle detection restricted**

The rear cross-traffic assist\* ⇒ *page 124*, *Rear cross-traffic assist* is not available. Either the ESC is switched off, or the radar sensors may be covered by a bike rack, stickers, leaves, snow or other objects. Switch the ESC on, or clean the area in front of the sensors if necessary ⇒ *page 121*, *fig. 121*. If this message continues to be displayed, drive immediately to an authorized Audi dealer or authorized Audi Service Facility to have the malfunction repaired.

### Parking system plus\*

If a sensor or speaker is faulty, the  symbol will appear in front of/behind the vehicle in the Infotainment system display. If a rear sensor is faulty, only obstacles that are in areas **(A)** and **(B)** are shown ⇒ *page 131*, *fig. 128*. If a front sensor is faulty, only obstacles that are in areas **(C)** and **(D)** are shown.

### Peripheral cameras\*

There is a system malfunction if the  symbol appears and the corresponding area of the display is shown in black. The camera is not working in this area. ▶

Drive to an authorized Audi dealer or authorized Audi Service Facility immediately to have the malfunction corrected.

## Trailer hitch

Applies to: vehicles with a rear parking system/parking system plus/rearview camera/peripheral cameras and trailer hitch

When the trailer socket is in use, the parking system rear sensors are not activated when you shift into reverse gear or when you press the **P** button. This results in the following restrictions.

### Rear parking system\*

There is no distance warning.

### Parking system plus\*

There is no distance warning for the rear. The front sensors remain activated. The visual display switches to trailer mode.

### Rearview camera\*/peripheral cameras\*

There is no distance warning for the rear. The front sensors remain activated. The visual display switches to trailer mode. The rearview camera image will not show the orientation lines and the blue surfaces.

#### Tips

Trailer hitches that are not installed at the factory may cause the parking system to malfunction or they may restrict its function.

## Intelligent Technology

### Electronic Stabilization Control (ESC)

#### Description

Electronic Stabilization Control (ESC) supports driver safety. It reduces the risk of slipping and improves driving stability. ESC detects critical situations such as when the vehicle is oversteering and understeering or the wheels are spinning. The vehicle is stabilized by applying the brakes or reducing engine torque. When the ESC engages, the  indicator light blinks in the instrument cluster.

The following systems are integrated in the ESC:

#### Anti-lock braking system (ABS)

ABS prevents the wheels from locking when braking. The vehicle can still be steered even during hard braking. Apply steady pressure to the brake pedal. Do not pump the pedal. A pulsing in the brake pedal indicates that the system is acting to stabilize the vehicle.

#### Brake assist system

The brake assist system can decrease braking distance. It increases braking power when the driver presses the brake pedal quickly in emergency situations. You must press and hold the brake pedal until the dangerous situation is over. In vehicles with adaptive cruise control\*, the brake assist system is more sensitive if the distance detected to the vehicle driving ahead is too small.

#### Anti-Slip Regulation (ASR)

ASR reduces engine power when the drive wheels begin spinning and adapts the force to the road conditions. This makes it easier to start, accelerate and drive up hills.

#### Electronic Differential Lock (EDL)

EDL applies the brakes to a wheel that starts spinning and transfers the drive power to the other driving wheels. This function is not available at higher speeds.

In extreme cases, EDL automatically switches off to keep the brake on the braked wheel from overheating. The vehicle is still working correctly. EDL will switch on again automatically when conditions have returned to normal.

#### Power steering

The ESC can also support vehicle stability through steering.

#### Selective wheel torque control

Selective wheel torque control is used when driving on curves. Braking is targeted toward the wheels on the inside of the curve as needed. This allows more precise driving in curves.

#### Automatic post-collision braking system

The “automatic post-collision braking system” can help to reduce the risk of sliding and of additional collisions after an accident. If the airbag control module detects a collision, the vehicle is braked by the ESC.

The vehicle does not brake automatically if:

- the driver presses the accelerator pedal, or
- the ESC, the brake system or the vehicle electrical system are not functioning.

#### WARNING

- The ESC and its integrated systems cannot overcome the limits imposed by natural physical laws. This is especially important on slippery or wet roads. If the systems begin acting to stabilize your vehicle, you should immediately alter your speed to match the road and traffic conditions. Do not let the increased safety provided tempt you into taking risks. This could increase your risk of a collision.
- Please note the risk of a collision increases when driving fast, especially through curves and on slippery or wet roads, and when driving too close to objects ahead. The ESC and its integrated systems cannot always prevent collisions - there is still a risk of accidents!

– Press the accelerator pedal carefully when accelerating on smooth, slippery surfaces such as ice and snow. The drive wheels can spin even when these control systems are installed and this can affect driving stability and increase the risk of a collision.

**i Tips**

– The ABS and ASR only function correctly when all four wheels have a similar wear

condition. Different tire sizes can lead to a reduction in engine power.

- You may hear noises when the systems described are working.
- Applies to: vehicles with roof racks supplied by the factory: when installing the roof rack supplied by the factory on the roof rail, sensor technology is used to adjust the ESC to any possible change in the vehicle's center of gravity resulting from the load.

**Switching on and off**

ESC turns on automatically when you start the engine.

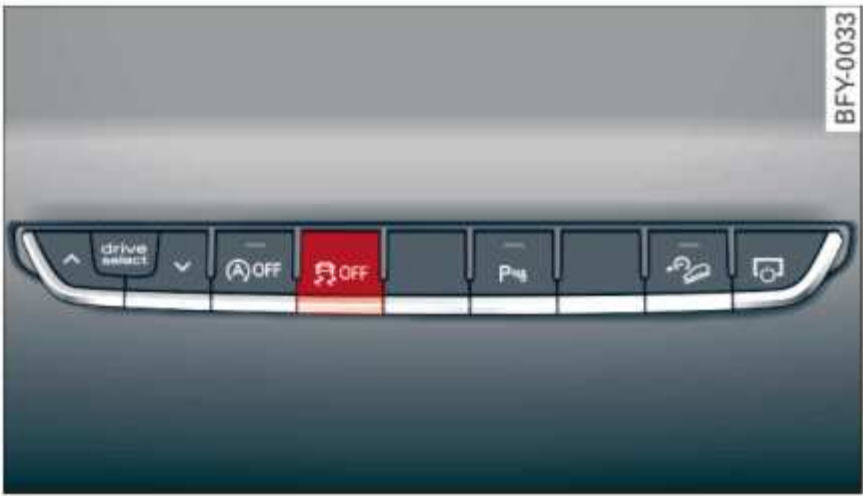

Fig. 146 Center console with the OFF button

The following examples are unusual situations where it may make sense to switch offroad mode on to allow the wheels to spin:

- Rocking the vehicle to free it when it is stuck
- Driving in deep snow or on loose ground
- Driving with snow chains
- Driving on rough terrain when much of the car's weight is lifted off the wheels (axle articulation)
- Driving downhill while braking on loose ground

The ESC is designed to function in levels. Depending on the level that is selected, the stabilization function of the ESC is limited or switched off. The amount of stabilization control will differ depending on the level.

For your safety, switch the offroad mode off in advance.

**ESC levels**

	Offroad mode on	ESC/ASR off	Offroad mode off or ESC/ASR on
<b>Behavior</b>	The ESC and ASR stabilization functions are limited ⇒ ⚠.	The stabilization function is not available ⇒ ⚠. ESC and ASR are switched off.	The full stabilization function of the ESC and ASR is available again.
<b>Operating</b>	Press the OFF button briefly.	Press and hold the OFF button longer than three seconds.	Press the OFF button again.
<b>Indicator lights</b>	OFF turns on.	OFF and ESC OFF turn on.	OFF turns off or OFF and ESC OFF turn off.
<b>Messages</b>	<b>Stabilization control (ESC): offroad. Warning! Reduced stability</b>	<b>Stabilization control (ESC): off. Warning! Restricted stability</b>	<b>Stabilization control (ESC): on</b>

### WARNING

You should only switch offroad mode on or switch ESC/ASR off if your driving abilities and the traffic conditions permit. There is a risk of sliding.

- The stabilization function is limited when offroad mode is switched on. The driving wheels could spin and the vehicle could swerve, especially on slick or slippery road surfaces.
- There is no vehicle stabilization when ESC/ASR are switched off.

### Hill descent assist

*Hill descent assist makes it possible to drive down a hill at a constant speed.*

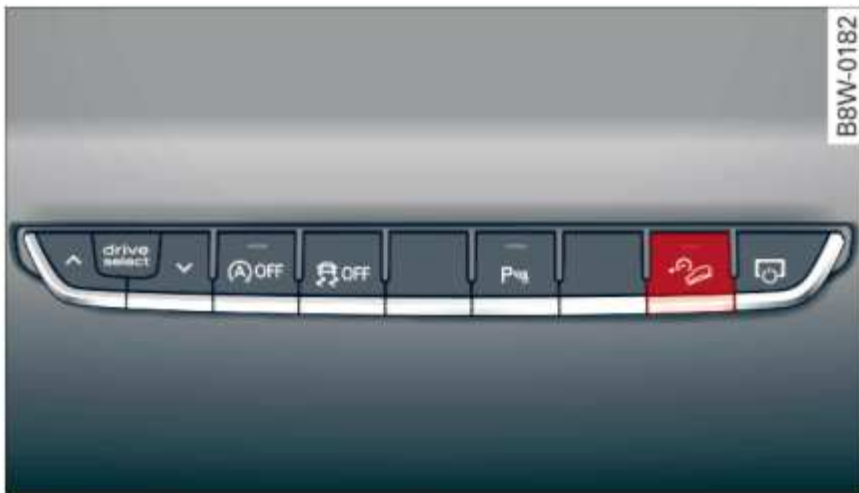





Fig. 147 Center console: hill descent assist button

- ▶ To switch hill descent assist on, press the  button. The LED in the button turns on.
- ▶ Press the button again to switch it off. The LED in the button turns off.

Hill descent assist brakes all four wheels automatically in order to limit speed when driving either forward or reverse on hills with a grade from approximately 6 to 60%. The wheels will not lock up because the ABS remains activated.

When hill descent assist is on, the speed your vehicle was traveling when it entered the hill is maintained. It is only possible to switch on the assist when driving slower than 37 mph (60 km/h). The assist begins shortly after you start driving and continues up to approximately 19 mph (30 km/h). The driver can increase or decrease the vehicle speed within these limits by pressing the accelerator or brake pedal.

However, there must be enough traction. Hill descent assist **cannot** function as expected, if for example the hill is icy or if the surface is loose ⇒ .

Active regulation of a speed up to approximately 19 mph (30 km/h) is signaled in the instrument cluster by an indicator light . The  indicator light turns on in the ready mode.

The system does not work at speeds between approximately 19 and 37 mph (30 and 60 km/h). The system is then in ready-mode. This is indicated by the LED in the button turning on. The system automatically switched off when you drive faster than 37 mph (60 km/h). The LED will also turn off in this scenario.

Hill descent assist is automatically activated under the following conditions:

- the LED in the button turns on
- the vehicle speed is lower than 19 mph (30 km/h)
- the hill angle is at least approximately 6%

### WARNING

- Always adapt your speed to the weather, road and traffic conditions. Do not let the increased safety provided tempt you into taking risks, because this increases the risk of an accident.
- The hill descent assist system cannot overcome the laws of physics. Your driving style must always be adapted to the current road and traffic conditions.
- Hill descent assist may not be able to hold your vehicle at a constant speed under all conditions while driving on a hill (for example if ground under the vehicle is loose).

## Brakes

### New brake pads

New brake pads do not achieve their full braking effect during the first 250 mi (400 km). They must be “broken in” first. However, you can compensate for the slightly reduced braking force by pressing firmly on the brake pedal. Avoid heavy braking during the break-in period. ▶

## Wear

Brake pad wear depends largely on the way the vehicle is driven and on operating conditions. This is especially true if you are driving frequently in the city and on curves or with a sporty driving style.

## Operating noise

Noises may occur when braking depending on the speed, braking force and outside conditions such as temperature and humidity.

## Wet conditions or road salt

In certain situations, for example after driving through water, in heavy rain or after washing your car, the braking effect may be reduced due to moisture or ice on the brake rotors and brake pads. The brakes must be “dried” first with a few careful brake applications.

At higher speeds and with the windshield wipers turned on, the brake pads press against the brake rotors for a short amount of time. This action, which is not felt by the driver, happens at regular intervals and ensures a better reaction time for the brakes in wet weather.

The braking effect can also be reduced if you are driving on salted roads and you do not apply the brakes for long periods of time. The layer of salt on the brake rotors and pads must be worn off first when the brakes are applied.

## Corrosion

Leaving the vehicle parked for long periods of time, low mileage and avoiding heavy braking can contribute to corrosion on the brake rotors and to dirty brake pads.

If you usually avoid heavy braking or if there is corrosion present, occasional heavy braking at high speeds is recommended to clean the brake rotors and pads ⇒ .

## Brake system malfunction

If you notice that the brake pedal travel has *suddenly* increased, then a brake circuit in the dual-circuit brake system may have malfunctioned. Drive to an authorized Audi dealer or authorized Audi Service Facility immediately to have the

problem corrected. On the way there, drive with reduced speed and keep in mind that you will need a longer distance to stop and you will need to press the brake pedal harder.

## Low brake fluid level

When the brake fluid level is low, malfunctions in the brake system may occur. The brake fluid level is electronically monitored.

## Brake booster

The brake booster amplifies the pressure you apply to the brake pedal.

### WARNING

- Only apply the brakes for the purpose of cleaning the brake system when road and traffic conditions permit. You must not endanger other road users. This increases the risk of an accident.
- Never let the vehicle roll while the engine is stopped because this increases the risk of an accident.
- Never place objects in the driver's footwell. An object could end up in the area around the pedals and prevent you from using them. You would not be able to use the pedals if sudden driving or braking maneuvers were needed, which increases the risk of an accident.
- Only use floor mats that do not obstruct the area around the pedals and that can be securely fastened in the footwells.
- To reduce the risk of injury, do not place your foot under the brake pedal.

### Note

- Never let the brakes “rub” by pressing the pedal lightly when braking is not actually necessary. This causes the brakes to overheat and increases braking distance and causes wear.
- Before driving downhill a long distance on a steep hill, decrease your speed and select a lower gear. This makes use of the engine braking effect and relieves the brakes. If you need to brake additionally, brake in intervals and not continuously.

**i Tips**

- If the brake booster is not working, you must press the brake pedal with much more force than normal.
- If you retrofit your vehicle with a front spoiler, wheel covers or similar items, make sure that the air flow to the front wheels is not interrupted. Otherwise the brake system can become too hot.

## Electromechanical steering, Dynamic steering

The electromechanical steering supports the driver's steering movements.

Power steering adapts *electronically* based on the vehicle speed.

### Indicator lights and messages

 **Steering: malfunction! Please stop vehicle**

If this indicator light turns on and stays on and this message appears, the power steering may have failed.

Stop the vehicle in a safe location as soon as possible. Do **not** continue driving. See an authorized Audi dealer or authorized Audi Service Facility for assistance.

 **Steering: malfunction! You can continue driving**

If the indicator light turns on and the message appears, the steering wheel may be more difficult to move or more sensitive than usual. The steering wheel may also be at an angle when driving straight.



Drive slowly to an authorized Audi dealer or authorized Audi Service Facility to have the malfunction corrected.

 **Dynamic steering: correcting steering wheel position**

If the indicator light turns on and this message appears, the dynamic steering\* is reinitializing. The steering wheel will be easy to move after starting the engine. Reinitialization might be

necessary if the steering wheel was moved while the engine was switched off. The display turns off if the initialization was successful.

**i Tips**

- If the  or  indicator light only stays on for a short time, you may continue driving.
- The dynamic steering stability systems ⇒ *page 140* are not available in the event of a system malfunction.
- For additional information on dynamic steering, see ⇒ *page 125*.

## All-wheel drive (quattro)

### General information

In all wheel drive, the driving power is distributed between all four wheels when needed. This happens automatically depending on your driving behavior as well as the current road conditions. Also see ⇒ *page 140, Electronic Stabilization Control (ESC)*.

The all-wheel drive system distributes the driving power variably to the front and rear axle. It works together with selective wheel torque control, which activates when driving through curves ⇒ *page 140*. With the sport differential\*, power distribution to the rear wheels is variable and can be adjusted using the drive select ⇒ *page 125*.

The all wheel drive concept is designed for high engine power. Your vehicle is exceptionally powerful and has excellent driving characteristics both under normal driving conditions and on snow and ice. Always read and follow safety precautions ⇒ .

### Winter tires

By using all wheel drive, your vehicle has good *forward* motion with standard tires in winter conditions. However, using winter or all season tires on *all four* wheels in the winter is recommended, because this will improve the *braking* effect.

### Snow chains

If there are snow chain laws, snow chains must also be used on vehicles with all wheel drive ⇒ *page 340, Snow chains*.

## Replacing tires

For vehicles with all wheel drive, only wheels with the same rolling circumference should be used. Avoid using tires with different tread depths  
⇒ page 332, *New tires or wheels*.

### WARNING

- Also, in vehicles with all wheel drive, adapt your driving style to the current road and traffic conditions. Do not let the increased safety provided tempt you into taking risks, because this increases the risk of an accident.
- The braking ability of your vehicle is limited to the traction of the wheels. In this way, it is not different from a two wheel drive vehicle. Do not be tempted to accelerate to a high speed when the road is slippery, because this increases the risk of an accident.
- Note that on wet streets, the front wheels can “hydroplane” if driving at speeds that are too high. Unlike front wheel drive vehicles, the engine does not rev higher suddenly when the vehicle begins hydroplaning. For this reason, adapt your speed to the road conditions to reduce the risk of an accident.

## Energy management

Your vehicle is equipped with an intelligent energy management system for distributing electricity. This significantly improves the starting ability and increases the vehicle battery life.

### Tips

- If you drive short distances frequently, the vehicle battery may not charge enough while driving. As a result, convenience functions for electrical equipment may be temporarily unavailable.
- The vehicle battery will gradually drain if the vehicle is not driven for long periods of time, or if electrical equipment is used when the engine is not running. To ensure that the vehicle can still be started, the electrical equipment will be reduced or switched off.

## Notice about data recorded by the Event Data Recorder and vehicle control modules

### Event Data Recorder

This vehicle is equipped with an Event Data Recorder (EDR). The main purpose of an EDR is to record, in certain crash or near crash-like situations, such as an airbag deployment or hitting a road obstacle, data that will assist in understanding how a vehicle's systems performed. The EDR is designed to record data related to vehicle dynamics and safety systems for a short period of time, typically 30 seconds or less. The EDR in this vehicle is designed to record such data as:

- How various systems in your vehicle were operating;
- Whether or not the driver and passenger safety belts were buckled/fastened;
- How far (if at all) the driver was depressing the accelerator and/or brake pedal; and,
- How fast the vehicle was traveling.

These data can help provide a better understanding of the circumstances in which crashes and injuries occur. NOTE: EDR data are recorded by your vehicle only if a non-trivial crash situation occurs; no data are recorded by the EDR under normal driving conditions and no personal data (e.g., name, gender, age, and crash location) are recorded. However, other parties, such as law enforcement, could combine the EDR data with the type of personally identifying data routinely acquired during a crash investigation.

To read data recorded by an EDR, special equipment is required, and access to the vehicle or the EDR is needed. In addition to the vehicle manufacturer, other parties, such as law enforcement, that have the special equipment, can read the information if they have access to the vehicle or the EDR.

Some state laws restrict the retrieval or downloading of data stored by EDRs installed in a vehicle for the express purpose of retrieving data after an accident or crash event without the owner's consent. ►

Audi will not access the EDR and/or similar data or give it to others -

- unless the vehicle owner (or lessee if the vehicle has been leased) agrees; or
- upon the official request by the police; or
- upon the order of a court of law or a government agency; or
- for the defense of a lawsuit through the judicial discovery process.
- Audi may also use the data for research about vehicle operation and safety performance or provide the data to a third party for research purposes without identifying the specific vehicle or information about the identity of its owner or lessee and only after the recorded vehicle data has been accessed.

### Vehicle control modules

Your vehicle is also equipped with a number of electronic control modules for various vehicle systems, such as engine management, emission control, airbags, and safety belts.

These electronic control modules record data during normal vehicle operation that may be needed by trained technicians for diagnostic and repair purposes. The recording capability of these modules is limited to data (no sound is recorded). Only a small amount of data is actually recorded over a very limited period of time, or stored when a system fault is detected by a control module. Some of the data stored may relate to vehicle speed, direction, or braking, as well as restraint system use and performance in the event of a crash. Stored data can also only be read and downloaded with special equipment that is directly connected to the vehicle.

#### Tips

Your vehicle may be equipped with Audi connect. Your use of certain Audi connect features requires wireless services that are provided by a third party wireless telecommunications provider. For details regarding how information obtained through Audi connect is collected, processed, transmitted, used, and shared, please see your contract with the wireless telecommunications provider.

## Multi Media Interface

### Traffic safety information

Audi recommends performing certain Infotainment system functions, such as entering a destination, only when the vehicle is stationary. Always be prepared to stop operating the Infotainment system in the interest of your safety and the safety of other road users.

#### WARNING

Only use the Infotainment system when traffic conditions permit and always in a way that allows you to maintain complete control over your vehicle.

#### Tips

Certain functions are not available while driving.

## Introduction

The Multi Media Interface, or MMI for short, combines various systems for communication, navigation\* and entertainment in your Audi. You can operate the MMI using the MMI control panel, the multifunction steering wheel or the voice recognition system\*.

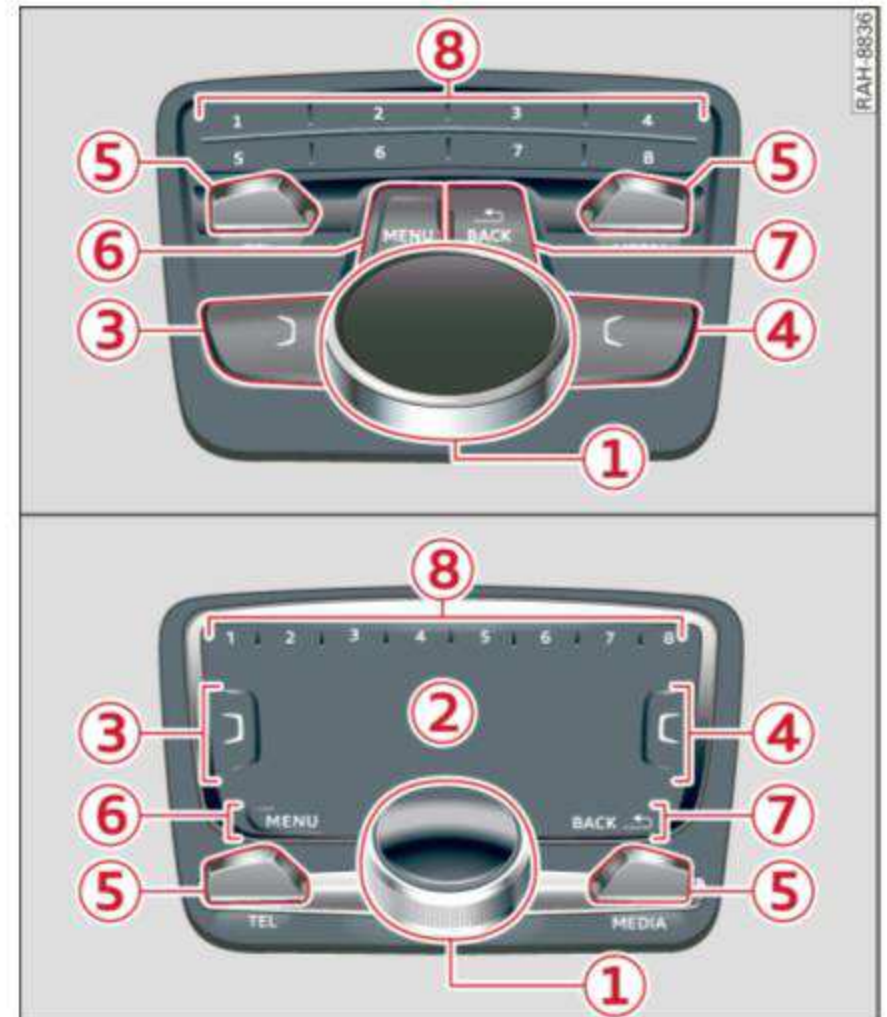

**Fig. 148** MMI control panels - integrated shortcut keys  
Top: without MMI touch Bottom: with MMI touch

### MMI control panel overview

①	Control knob with joystick function	149, 153
②	MMI touch control pad*	151
③	Left control button	150
④	Right control button	150
⑤	Buttons for opening menus directly	149
⑥	MENU button	149
⑦	BACK button	149
⑧	Shortcut keys	155

## MMI On/Off knob with joystick function

### Operating



Fig. 149 MMI On/Off knob with joystick function

**Switching the MMI on/off:** the MMI can be switched on/off manually.

- **Switching on manually:** press the On/Off knob ① briefly ⇒ fig. 149. Or: press the **MENU** button ⑥ ⇒ page 147, fig. 148 or one of the buttons to open the menus directly ⑤.
  - **Switching off manually:** press and hold the On/Off knob ① ⇒ fig. 149 until the MMI switches off. If the MMI has been switched off manually, it does *not* switch on again automatically the next time the ignition is switched on.
- Additional functions:**
- **Adjusting the volume:** turn the On/Off knob ① ⇒ fig. 149.
  - **Muting:** press the On/Off knob ① ⇒ fig. 149 briefly.
  - **Selecting the previous/next function (for example, a radio station/track):** press the On/Off knob ① ⇒ fig. 149 briefly toward the left ⏮ or right ⏭.
  - **Fast forwarding/rewinding (for example songs):** press and hold the On/Off knob ① ⇒ fig. 149 toward the left ⏮ or right ⏭.

### ⚠ WARNING

Adjust the volume of the audio system so that signals from outside the vehicle, such as police and fire sirens, can be heard easily at all times.

### **i** Tips

The MMI switches off automatically if the engine is not running and the vehicle battery is low.

## Infotainment system display

### Switching on/off

- ▶ Press the  button to switch the Infotainment system on and off.

When the MMI is switched on and the display is switched off, you can operate certain functions using the On/Off knob with the MMI joystick function ⇒ page 148.

### **i** Tips

There may be delays when switching on the display.

### Information on display images

The display version depends on vehicle equipment.



Fig. 150 Display version A



Fig. 151 Display version B

Additional content (such as album cover and map material) is shown on display version B, if applicable ① ⇒ fig. 151. Because the other content ▶

shown on the displays is nearly identical between the two versions, this manual will primarily describe display version A.

## MMI operation

### Selecting and confirming a function



Fig. 152 Operating the control knob

### Selecting and confirming a function in a menu/list

- ▶ **Selecting a function:** turn the control knob ① ⇒ *fig. 152* to the desired function (such as selecting a frequency).
- ▶ **Confirming a selection:** press the control knob ② ⇒ *fig. 152*.

### Returning to functions at higher levels

- ▶ Press the **BACK** button ⑦ ⇒ *page 147, fig. 148*.

### Opening the main menu/menu



Fig. 153 Diagram: main menu

### Opening the main menu

- ▶ Press the **MENU** button ⑥ ⇒ *page 147, fig. 148*. The MMI menus (such as **Radio**) are displayed ⇒ *fig. 153*. Then you can select and confirm a function using the control knob.

### Opening a menu directly

- ▶ Press the applicable button to directly open the menus ⑤ ⇒ *page 147, fig. 148* in the direction of the desired menu (such as **RADIO**). Then you can select and confirm a function using the control knob.

**Opening the selection menu/options menu with the control buttons**

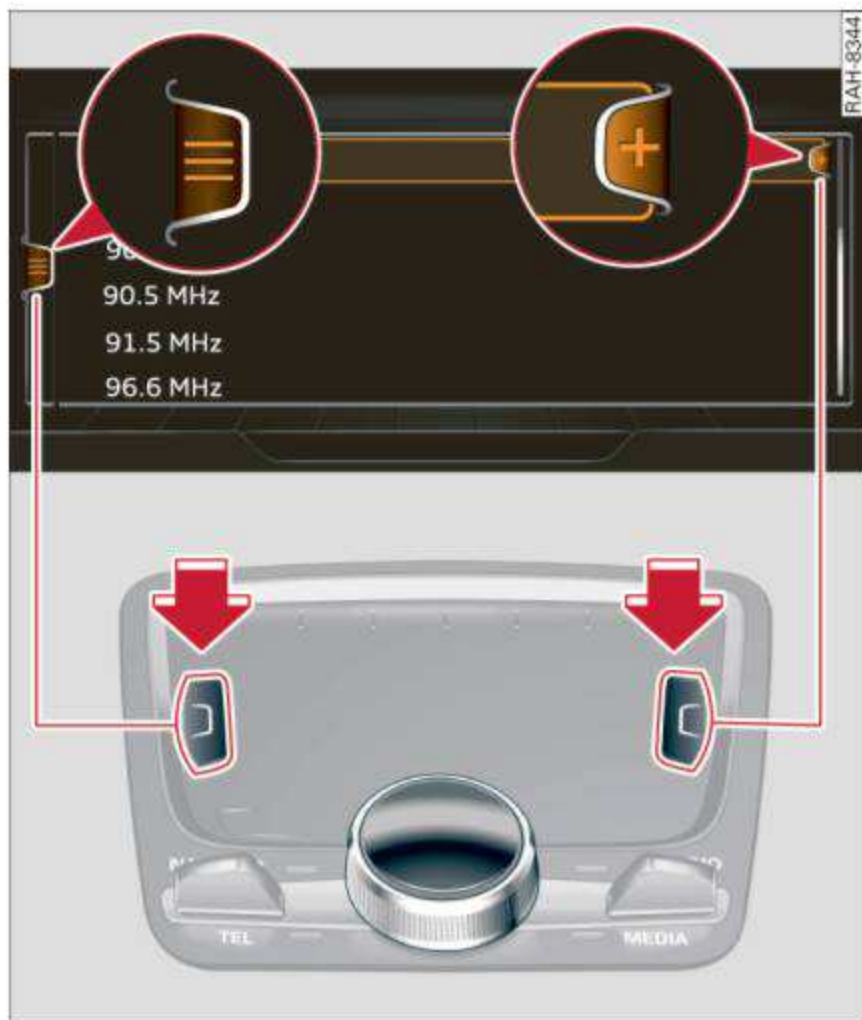

Applies to: MMI control panel with integrated control buttons on the MMI touch control pad  
**Fig. 154** Control buttons on the MMI control panel

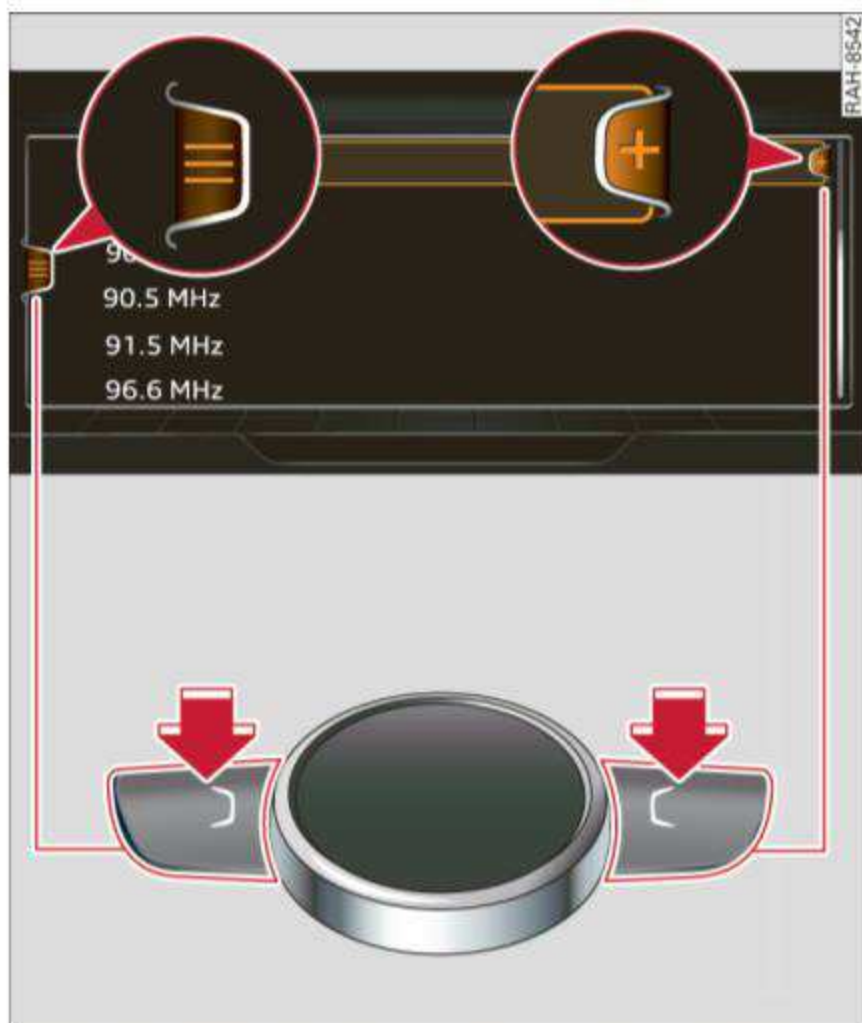

Applies to: MMI control panel with separate control buttons on the MMI control panel  
**Fig. 155** Control buttons on the MMI control panel

**Selection menu:** through the selection menu, you can open additional functions within a menu item (such as **Radio**).

Requirement: the selection menu symbol must be displayed in the Infotainment system display ⇒ *fig. 155*.

**Opening/closing the selection menu:** press the left control button ⇒ *fig. 155*. Then you can select and confirm a function using the control knob.

**Options menu:** using the options menu, you can select and confirm context-dependent functions as well as settings within a menu item (such as **Radio**).

Requirement: the options menu symbol  must be displayed in the Infotainment system display ⇒ *fig. 155*.

**Opening/closing the options menu:** press the right control button ⇒ *fig. 155*. Then you can select and confirm a function using the control knob.

**Information about menu paths**

*This guide shows you at a glance the paths for opening a desired menu and its settings and functions.*

**Example of a path**

- ▶ Select: **RADIO** button > left control button > **FM**.

**Following the path**

- ▶ Press the **RADIO** button.
- ▶ Press the left control button.
- ▶ Turn the control knob to the **FM** menu item to select it.
- ▶ Press the control knob to confirm the selected **FM** menu item.
- ▶ The selected and confirmed function is executed. In this example, the **FM** frequency band is set.

## MMI touch

### MMI touch control pad

Applies to: vehicles with MMI touch

You can enter data using handwriting recognition on the MMI touch control pad.



Fig. 156 Example: entering a navigation destination using the MMI touch

The MMI touch control pad is located between the control buttons ⇒ *fig. 156*.

### Entering numbers, letters, and symbols

Applies to: vehicles with MMI touch

The MMI touch allows you to enter data on the MMI touch control pad using handwriting recognition.



Fig. 157 Display when MMI touch is active

Requirement: it must be possible to enter text or numbers and the symbol ① ⇒ *fig. 157* must appear in the Infotainment system display.

- **Initial entry:** write an individual upper case or lower case letter or number/symbol on the MMI touch control pad using your finger. A symbol that is recognized clearly by the system is displayed in the Infotainment system display ① ⇒ *page 151, fig. 156*, confirmed with an audible signal if necessary, and transferred to the input field.
- **Entering spaces:** move your finger across the MMI touch control pad from left to right.
- **Deleting characters:** move your finger across the MMI touch control pad from right to left.
- **Selecting the input suggestion:** press the control knob.
- **Switching directly to the results list:** turn the control knob to the right
- **Opening the speller:** select the right control button > **Open speller**. Text or numbers are entered using the speller ⇒ *page 155*.
- **MMI touch volume:** press the right control button. See ⇒ *page 250*.

### Moving the crosshairs

Applies to: vehicles with MMI touch

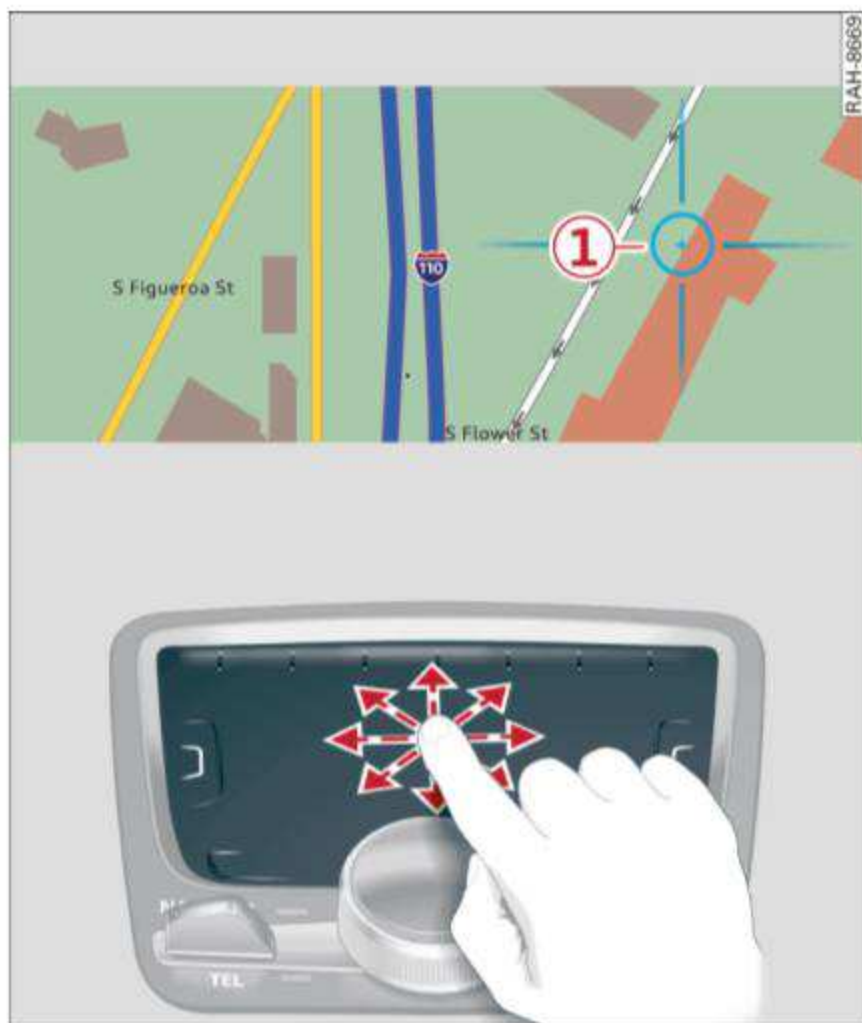

Applies to: vehicles with automatic transmission and MMI touch

**Fig. 158** moving the crosshairs

### Moving the map

Applies to: vehicles with MMI touch

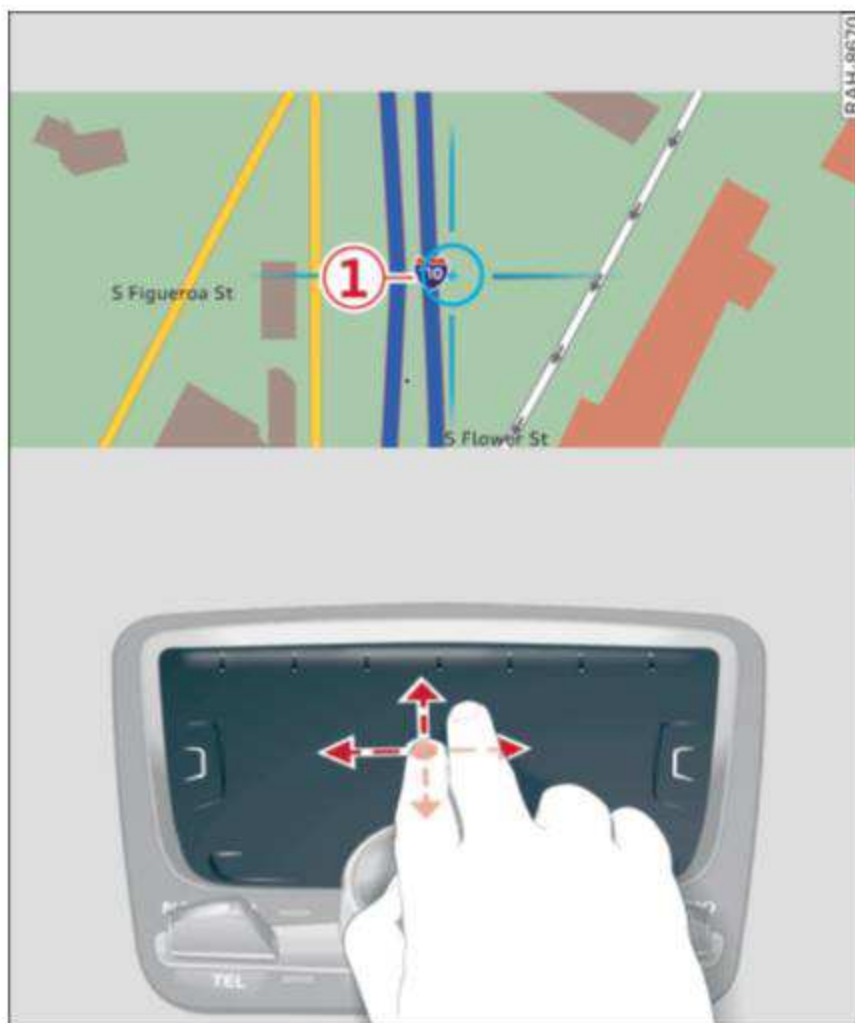

Applies to: vehicles with automatic transmission and MMI touch

**Fig. 159** moving the map

Requirement: a map must be displayed  
⇒ page 213.

- **Showing/hiding the crosshairs:** press the control knob to show the crosshairs ① ⇒ fig. 158. **Or:** press on the MMI touch control pad. Press the **[BACK]** button ⑦ ⇒ page 147, fig. 148 to hide the crosshairs again.
- **Moving the crosshairs on a map:** move the crosshairs shown in the desired direction using your finger on the MMI touch control pad ⇒ fig. 158.
- **Moving the crosshairs quickly:** when the crosshairs are visible ① ⇒ fig. 158, slide your finger quickly across the MMI touch control pad in the desired direction ⇒ fig. 158. The crosshairs will come to a stop after several seconds.

Requirement: a map must be displayed  
⇒ page 213.

- **Showing/hiding the crosshairs:** press the control knob to show the crosshairs ① ⇒ fig. 159. **Or:** press on the MMI touch control pad. Press the **[BACK]** button ⑦ ⇒ page 147, fig. 148 to hide the crosshairs again.
- **Moving the standard map/satellite map<sup>1)</sup>:** move the crosshairs shown in the desired direction using two fingers on the MMI touch control pad ⇒ fig. 159.
- **Moving the map quickly:** when the crosshairs are visible, pull two fingers across the MMI touch control pad quickly in the desired direction. The map will come to a stop after several seconds.

<sup>1)</sup> AUDI AG provides access to services from third party providers. Permanent availability cannot be guaranteed, because that depends on the third party provider.

## Zooming in/out on the map

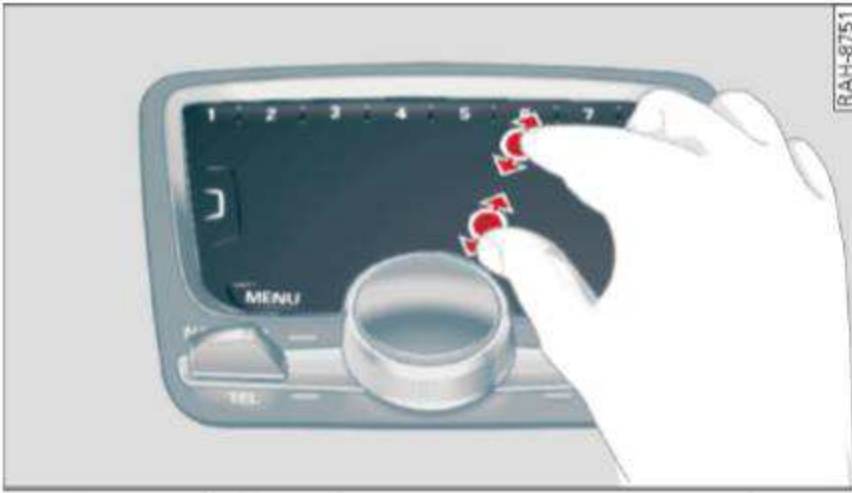

Applies to: vehicles with automatic transmission and MMI touch

Fig. 160 zooming in/out on the map

Requirement: a map must be displayed  
⇒ page 213.

- **Zooming in/out on the map:** press the control knob to show the crosshairs. Touch the MMI touch control pad with two fingers and pull your fingers apart or together ⇒ fig. 160.

Press the **BACK** button ⑦ to hide the crosshairs  
⇒ page 147, fig. 148.

## Adjusting the sound focus

Applies to: vehicles with MMI touch

Requirement: the **Balance/fader** function must be selected ⇒ page 249.

- **Moving the crosshairs for sound focus:** move your finger in the desired direction on the MMI touch control pad.
- **Storing the crosshairs location:** press the control knob twice. **Or:** press the **BACK** button ⑦ ⇒ page 147, fig. 148.

## Using the DVD main menu

Applies to: vehicles with MMI touch

Requirement: a DVD must be playing  
⇒ page 234. The DVD main menu is shown.

- **Selecting a menu item:** move your finger up/down or left/right on the MMI touch control pad.

## i Tips

The volume of the voice guidance prompts for the MMI touch\* can be adjusted separately  
⇒ page 250.

## Control knob with joystick function

### Operation

Applies to: vehicles with joystick function

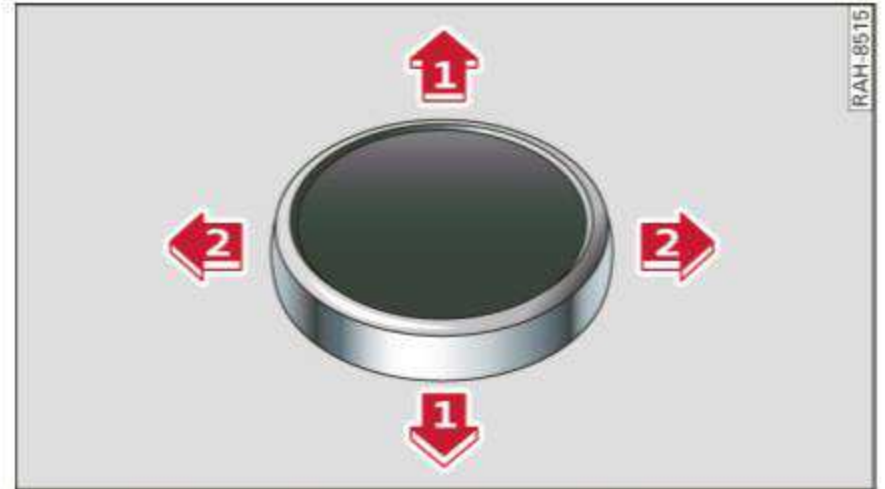

Applies to: vehicles with the joystick function

Fig. 161 operational concept for control knob with joystick function

You can push the control knob up or down ①  
⇒ fig. 161 or to the right or left ②.

## Opening the entertainment sliding menu

Applies to: vehicles with MMI touch

**Opening the entertainment sliding menu:** push the control knob down to open the entertainment sliding menu ③ ⇒ page 158, fig. 165. Then you can select and confirm a function.

**Closing the entertainment sliding menu:** push the control knob up to close the entertainment sliding menu. **Or:** press the **BACK** button ⑦ ⇒ page 147, fig. 148.

## Additional functions

Applies to: vehicles with joystick function

### Displaying the input field/switching to speller input

Push the control knob up ⇒ page 153, fig. 161 to reach the beginning of a list in the central area or the input field. If the input field is already open, switch directly to the speller in the input field by ►

## Multi Media Interface

pushing the control knob up again ⇒ *page 155, Letter/number speller.*

### On the map

Requirement: a map must be displayed  
⇒ *page 213.*

- **Displaying the input field:** push the control knob up.
- **Displaying route guidance:** when route guidance is active, you can also display the route guidance by pushing the control knob up ⇒ *page 208, fig. 187.*
- **Zooming in/out on the map (zoom):** turn the control knob to the right/left to zoom in/out on the map.

Applies to: vehicles without MMI touch with joystick function

- **Showing/hiding the crosshairs:** press the control knob. The crosshairs are shown on the map. Press the **BACK** button to hide the crosshairs.
- **Moving the crosshairs:** when the crosshairs are visible, turn the control knob in the direction the crosshairs should move. Press the control knob and hold it until the crosshairs are in the desired point on the map.
- **Additional options on the map:** see ⇒ *page 214*

### Adjusting the sound focus

Applies to: vehicles without MMI touch with joystick function

Requirement: the balance/fader function must be selected ⇒ *page 249.*

- **Moving the sound focus using the crosshairs:** the crosshairs can be moved horizontally. Turn the control knob to the left or to the right. Press the control knob to move the crosshairs vertically. Turn the control knob to the left or to the right. Press the control knob again to save the setting.

### Using the DVD main menu

Requirement: a DVD must be playing  
⇒ *page 234.* The DVD main menu is shown.

- **Selecting a menu item:** move the control knob with joystick function up or down or to the left or right.
- **Confirming a selection:** press the control knob.

## Opening the selection/options menu with the control knob

Applies to: vehicles with joystick function

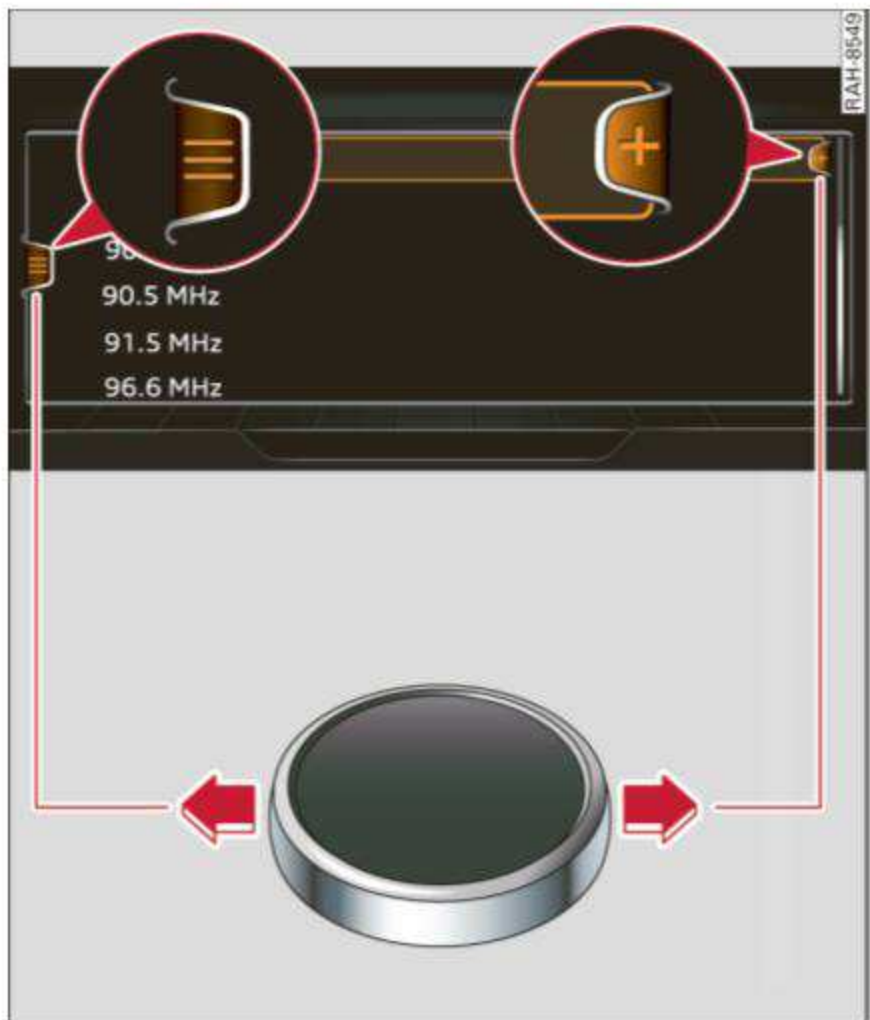

Applies to: MMI control panel with control knob and joystick function

**Fig. 162** Opening the selection/options menu with the control knob

Requirement: the selection menu symbol  $\text{⎵}$  must be displayed in the Infotainment system display ⇒ *fig. 162.*

**Opening/closing the selection menu:** push the control knob to the left ⇒ *fig. 162* to open the selection menu. Then you can select and confirm a function using the control knob.

Press the **BACK** button  $\text{⌂}$  ⇒ *page 147, fig. 148* to return to the function one level up.

Requirement: the options menu symbol  $\text{⊕}$  must be displayed in the Infotainment system display ⇒ *fig. 162.*

Press the **BACK** button  $\text{⌂}$  ⇒ *page 147, fig. 148* to return to the function one level up.

## Shortcut keys

Frequently used radio stations can be stored on the shortcut keys.

The shortcut keys are located on the MMI control panel ⑧ ⇒ page 147, fig. 148.

**Storing radio stations:** turn the control knob to the desired radio station in a list (for example, a radio station in the FM station list). Press and hold the desired shortcut key for several seconds. The active radio station will be stored on the shortcut key.

**Accessing a radio station:** press the shortcut key.

**Displaying a radio station:** swipe your finger over the shortcut keys.

**Deleting a stored radio station:** reset the **Shortcut keys** to the factory default settings ⇒ page 246.

### **i** Tips

It is not possible to enter numbers using the shortcut keys. Use the number speller ⇒ page 155 or MMI touch\* ⇒ page 151 to enter numbers.

## Letter/number speller

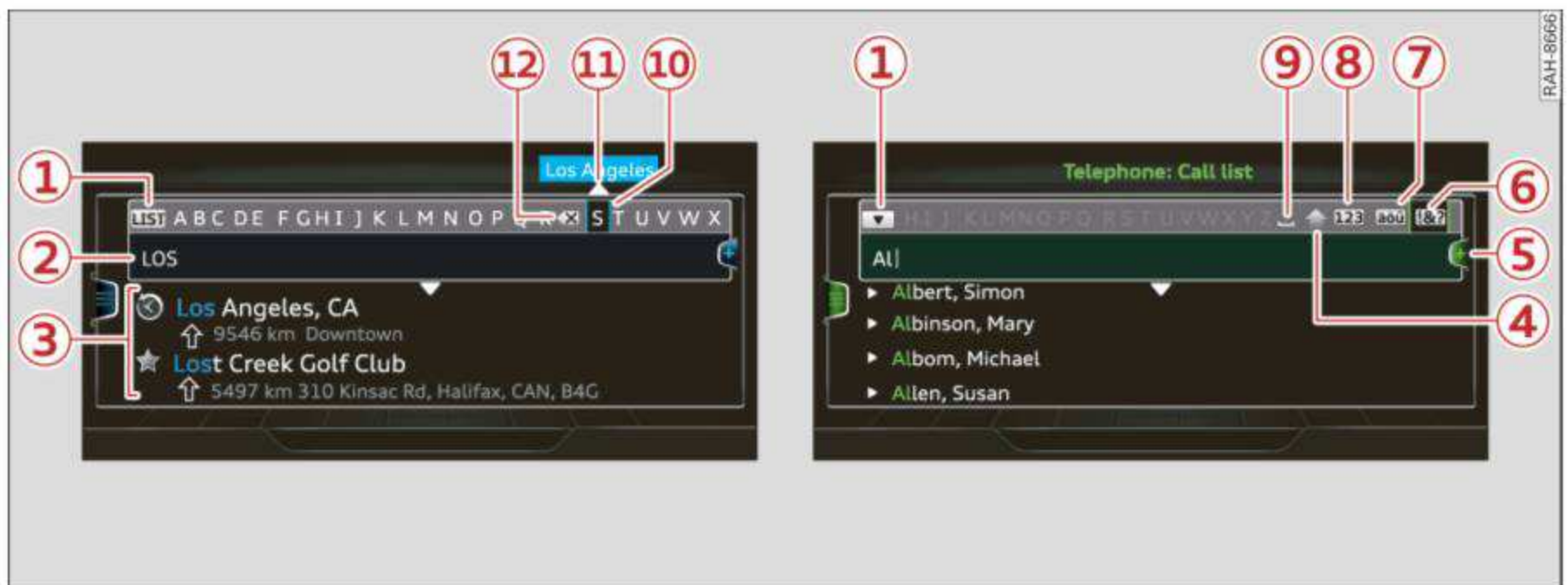



Fig. 163 Diagram: letter/number speller

You can enter letters, numbers and symbols in the MMI using the letter/number speller. This option is available when the input field ② is active ⇒ fig. 163.

- **Opening/closing the letter/number speller:** move the control knob up/down when the input field is active. **Or:** select the right control button > **Open speller/Close speller.**
- **Entering characters:** turn the control knob with the character selection ⑩ ⇒ fig. 163 to the desired symbol. Press the control knob to confirm the character. Your input is displayed in the input field ②. When you have entered all of the characters, select and confirm the **LIST** button ① ⇒ fig. 163. **Or:** push the control knob down.

- **Entering accented characters (such as â, ç, ñ, ö)\*:** turn the control knob with the character selection ⑩ ⇒ fig. 163 to a character. To open the selected accented characters, press and hold the control knob. Turn the control knob with the character selection ⑩ ⇒ fig. 163 to an accented character. Press the control knob to insert the accented character. To close the accented characters without selecting a character, press and hold the control knob again. **Or:** select and confirm **äöü** ⑦ ⇒ fig. 163. Select and confirm an accented character.
- **Deleting characters:** select and confirm **✕** ⑫ ⇒ fig. 163. To delete all characters in the input field, press and hold the control knob on **✕** until all characters in the input field are deleted. ▶

- **Entering special characters:** select and confirm  ⑥ ⇒ *fig. 163* or  ⑧. Select and confirm the desired special character (for example, a hyphen or period) with the number speller.
- **Input assistance:** in some cases such as in navigation\*, there is a word suggestion\* ⑪ ⇒ *fig. 163* based on available entries while you are entering data. You can select this suggestion by pushing the control knob upward.
- **Results list:** in some cases, such as in the directory, the system switches automatically to the results list based on available entries ③









⇒ *fig. 163*. Select and confirm a suggestion from the list.

Requirement: the input field ② ⇒ *fig. 163* must be active.

- **Switching between speller and MMI touch\*:** the handwriting recognition for the MMI touch control pad\* is activated automatically. Simply start writing.

### Overview of symbols in the speller

The symbols in the letter/number speller are explained in the following table:

	Symbol/Description	Description
①		Switches to the results list.
②	Input field	Displays the current input.
③	Results list	Displays a list with suggestions based on the letters already entered.
④		Switches from lower case to upper case letters or from upper case to lower case letters.
⑤		Opens additional speller options, for example <b>Close speller</b> and <b>Clear input field</b>
⑥		Character sets and special characters
⑦		Displays accented characters (such as â, ç, ñ, ö).
⑧		Switches from letter to number input or from number to letter input.
⑨		Adds a space in the input field.
⑩	Character selection	Highlights the selected character.
⑪		Inserts the suggested word* when you push the control knob up.
⑫		Deletes the character to the left of the cursor.

### Tips

Accented characters are not available for every letter.

## Free text search

Applies to: vehicles with free text search

Using the free text search, you can select the order that the search terms are entered in the input field.



Fig. 164 Example: free text search on telephone

Free text search is available in the **Vehicle\***, **Radio\***, **Media\***, **Telephone\***, **Navigation\*** and **Audi connect\*** menus.

### Opening free text search

- ▶ Select: **MENU** button > *desired menu item* (such as **Telephone**).
- ▶ Keep turning the control knob to the left until the **free text search** input field ① ⇒ *fig. 164* appears. **Or:** push the control knob up to open the input field ①.

The handwriting recognition for the MMI touch control pad\* is automatically activated. Simply start writing.

### Free text search for an entry

- ▶ Enter one or more search terms in any order into the input field. The individual search terms must be separated by spaces when entering.

An input suggestion to complete the entry\* ③ ⇒ *fig. 164* is shown depending on the input. Additional entries that contain the entered search terms are listed in the results list ② ⇒ *fig. 164*.

If the desired term is still not displayed, enter additional letters until it is displayed.

It is often enough just to enter the first letters of the search term in order for it to display in the results list. For example, in the **Telephone\*** menu, write the initials of the contact being searched, separated by a space.

### Selecting the input suggestion to complete the entry

Requirement: an input suggestion to complete the entry\* ③ ⇒ *fig. 164* must be displayed.

- ▶ **MMI touch input\***: press the control knob. **Or:** press on the MMI touch control pad\*.
- ▶ **Speller input**: push the control knob up.

### Selecting an entry from the results list

Requirement: at least one entry must be displayed in the results list ② ⇒ *fig. 164*.

- ▶ **MMI touch input\***: turn the control knob to the right. Select and confirm an entry from the list.
- ▶ **Speller input**: select and confirm **LIST** ① ⇒ *page 155, fig. 163*. **Or:** push the control knob down. Select and confirm an entry from the list.

# Menus and Symbols

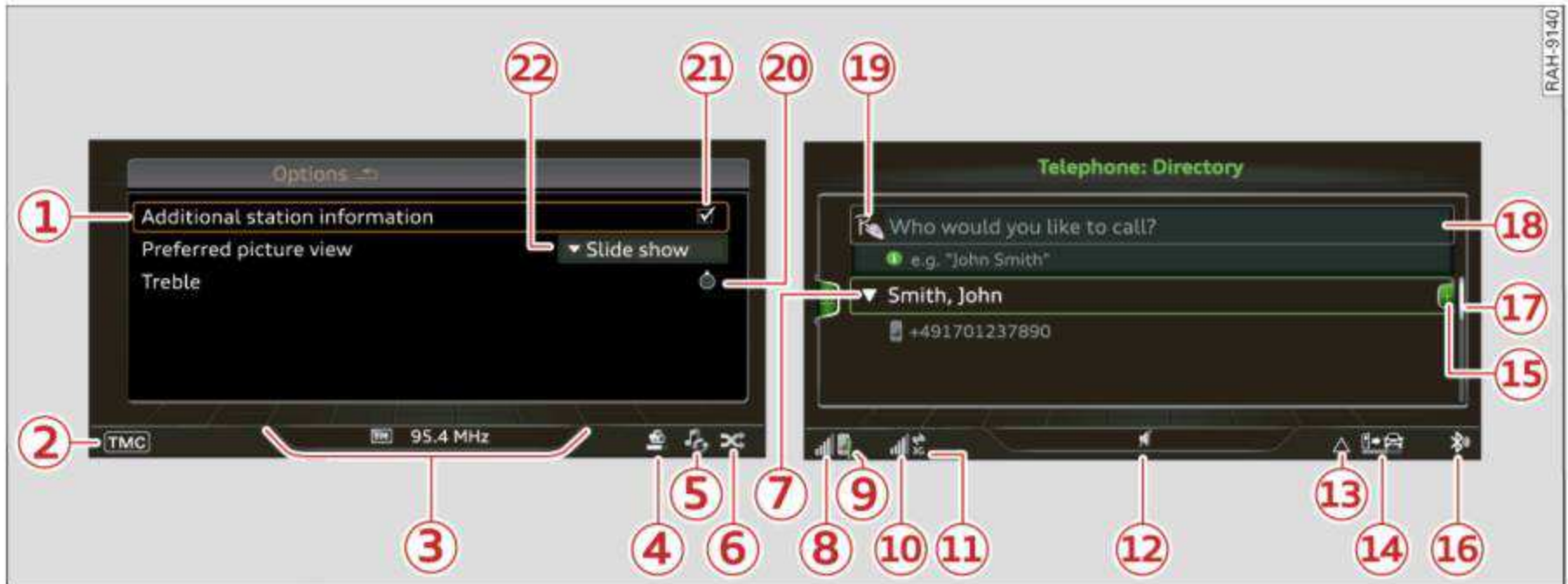

Fig. 165 Diagram: menus and symbols

Symbol/Description	Description
① Selected text	Selected function
② TMC	Receiving TMC/online traffic information ⇒ page 217
③ Entertainment sliding menu	Displays information about the media source that is currently selected or a situation (such as an incoming call). Depending on vehicle equipment, operation might also be possible using the open entertainment sliding menu (such as selecting a radio station or accepting a call) ⇒ page 153.
④ Jukebox* importing process	Importing audio/video files to the Jukebox ⇒ page 227
⑤ Repeat track	The track currently playing is repeated ⇒ page 238
⑥ Shuffle	All files on the playlist are played in random order ⇒ page 238, <b>Shuffle</b>
⑦ Arrow	Access information by pressing the control knob when the selected text is active
⑧ Telephone signal strength bars	Telephone signal strength
⑨ Exclamation point on the telephone	Indicates missed calls
⑩ Data connection signal strength bars*	Signal strength for the active data connection, or <b>PIN</b> : enter the PIN (SIM) <b>PUK</b> : enter the PUK
⑪ 2G/3G/LTE*	Network coverage for the active data connection ⇒ page 194 <b>2G</b> : GSM network <b>3G</b> : UMTS network <b>LTE*</b> : LTE network
⑫ Mute	The audio source is muted ⇒ page 249
⑬ Roaming	Outside the mobile network for the connected cell phone or the inserted SIM card

	Symbol/Description	Description
⑭	Importing process	Import/update the contacts in the directory or the call lists
⑮	Options menu*	Select and confirm context-dependent functions as well as settings within a menu item
⑯	Bluetooth*	Bluetooth device connected ⇒ <i>page 228</i> or ⇒ <i>page 174</i>
⑰	Scroll bars	Indicates a long list. Move within lists by turning the control knob.
⑱	Input field	Information that can be changed using the letter/number speller ⇒ <i>page 155</i> or the MMI touch* ⇒ <i>page 151</i> .
⑲	MMI touch*	Possible to operate using the MMI touch control pad*
⑳	Knob	Setting for the selected function by turning the control knob
㉑	Check boxes	You can switch certain functions on <input checked="" type="checkbox"/> or off <input type="checkbox"/> by pressing the control knob.
㉒	Selection list	Settings for the selected function that are accessed by pressing the control knob

# Multifunction steering wheel

## Introduction

Applies to: vehicles with multifunction steering wheel

In the driver information system display, you can control numerous Infotainment functions using the multifunction steering wheel plus\*

⇒ *page 12* or the multifunction steering wheel\*  
⇒ *page 15*.

You can control additional Infotainment functions using the MMI control panel ⇒ *page 147* in the Infotainment system display.

### WARNING

Direct your full attention to driving. As the driver, you have complete responsibility for safety in traffic. Only use the functions in such a way that you always maintain complete control over your vehicle in all traffic situations.

## Radio

Applies to: vehicles with multifunction steering wheel and radio

Applies to: vehicles with multifunction steering wheel

▶ Press the **MODE** button on the multifunction steering wheel repeatedly until the Radio/Media tab is displayed.

Applies to: vehicles with multifunction steering wheel plus

▶ Press the **◀▶** button on the multifunction steering wheel repeatedly until the Radio/Media tab is displayed.  
▶ Press the left control button ⇒ *page 13*.

Depending on vehicle equipment, the following functions may be available in the driver information system.

- **Selecting the frequency band:** select and confirm a frequency band.
- **Selecting a station from the station list:** select and confirm a radio station.
- **Selecting a station from the presets list:** select and confirm **Presets** and then a radio station.

- **Opening a media source:** select and confirm **Switch to media**.

### Additional settings

- Select: right control button > *desired entry*.

See ⇒ *page 223*.

### Tips

Pay attention to the Infotainment system display if necessary. Depending on the selected function, it may be necessary to use the MMI control panel.

## Media

Applies to: vehicles with multifunction steering wheel and media

Requirement: a media drive must contain audio/video files ⇒ *page 226*.

Applies to: vehicles with multifunction steering wheel

▶ Press the **MODE** button on the multifunction steering wheel repeatedly until the Radio/Media tab is displayed.

Applies to: vehicles with multifunction steering wheel plus

▶ Press the **◀▶** button on the multifunction steering wheel repeatedly until the Radio/Media tab is displayed.  
▶ Press the left control button ⇒ *page 13*.

Depending on vehicle equipment, the following functions may be available in the driver information system.

- **Selecting a media source:** select and confirm a source such as the SD card.
- **Switching to the radio:** select and confirm **Switch to radio**.
- **Playing an audio/video file:** select and confirm a file.
- **Pausing/resuming playback:** press the right thumbwheel **Ⓜ** ⇒ *page 14, fig. 11*. To resume playback, press the right thumbwheel again.
- **Opening additional track information:** select: right control button > **Show "Now Playing" screen**.

For additional information, see ⇒ *page 238*. ▶

## Tips

- Always follow the information found in ⇒ *page 225*.
- Please note that within a media source in the driver information system, only playlists that were selected through the MMI control panel can be played ⇒ *page 235*.
- Pay attention to the Infotainment system display if necessary. Depending on the selected function, it may be necessary to use the MMI control panel.

## Telephone

Applies to: vehicles with multifunction steering wheel and telephone



Fig. 166 Example: telephone functions in the driver information system

Requirement: a cell phone must be connected to the MMI ⇒ *page 174*.

Applies to: vehicles with multifunction steering wheel

- ▶ Press the **MODE** button on the multifunction steering wheel repeatedly until the Telephone tab is displayed.

Applies to: vehicles with multifunction steering wheel plus

- ▶ Press the **◀▶** button repeatedly until the Telephone tab is displayed.
- ▶ Press the left control button ⇒ *page 13*.

Depending on vehicle equipment, the following functions may be available in the driver information system.

- **Accessing a contact:** select and confirm **Call list / Favorites / Directory**. Select and confirm a contact.

**Directory contacts\***: the driver information system only displays directory contacts that have a phone number stored. If several phone numbers are stored with a contact, the list of stored numbers is displayed first when the entry is selected.

**Recent calls\***: the recent calls list contains all incoming, outgoing and missed calls.

**Caller information\***: the *name, phone number* or **Unknown** appears in the driver information system display depending on whether the caller has been stored in the directory and if the phone number has been transmitted.

### Functions during an incoming call

- **Accepting a call:** press the left thumbwheel when there is an incoming call.
- **Declining a call:** select and confirm **Decline** when there is an incoming call.
- **Ending a phone call:** select and confirm **End call**.

### Functions during a phone call:

- **Making an additional call\***: select and confirm **Hold call**. Press the left control button > **Directory** or **Call list** > *the desired entry*.
- **Answering a call while in a call and while there is another call on hold\***: select and confirm **Answer**. The active call is replaced with the incoming call.

Additional functions include:

**Mute\***: if you select and confirm this function, the other person on the phone cannot hear you. You can hear the other person.

**Holding/resuming a call\***: you can place the existing call on hold and resume it again.

**Swap call\***: you can alternate between two phone calls at the same time. One of the calls will be on hold. Selecting **End call** will end the active phone call. A call that was placed on hold stays on hold and can be taken off hold with **Resume**.

**Conference call\***: a call on hold and up to five active parties (depending on the cell phone service provider) can be added to a conference call. To make an additional call, put all participants in the current conference call on hold using **Hold** ▶

**call\***. By pressing the left control button, you can make additional calls from the directory or the call list. **Resume\*** takes all parties off hold.

### Tips

- The telephone functions can only be controlled with the multifunction steering wheel if the telephone equipment was installed *at the factory*.
- The telephone functions depend on the cell phone and whether they are supported by your cell phone service provider or not.
- The **Call waiting\*** function must be activated in your cell phone and in the MMI in order to be alerted when there is an incoming call during an active call. The call options depend on the cell phone and service provider. You can obtain more information from your cell phone service provider.

## Navigation

### Operation in the driver information system

Applies to: vehicles with multifunction steering wheel and navigation system

Requirement: a destination must be entered ⇒ *page 204* and the route guidance must be started.

- ▶ Press the  button on the multifunction steering wheel repeatedly until the Navigation tab is displayed.
- ▶ Press the left control button ⇒ *page 13*.

Depending on vehicle equipment, the following functions may be available in the driver information system.

- **Displaying navigation during active route guidance:** select and confirm **Map\*** / **Street view\*** or **Arrow view\***.
- **Showing the map when route guidance is not active\*:** select and confirm **Map\***.
- **Accessing last destinations:** select and confirm **Last destinations** > *the desired destination*.
- **Accessing favorites\*:** select and confirm **Favorites** > *the desired destination*.

- **Starting route guidance to the stored home address:** select and confirm **Cancel route guidance** if necessary and then **Home address**.

If you have not started any route guidance, a compass (analog instrument cluster) or the arrow view (monochrome instrument cluster) is displayed depending on the equipment. The map is displayed in the Audi virtual cockpit\*.

### Canceling active route guidance

- Select: right control button > **Cancel route guidance**

### Additional settings

- Select: right control button > *desired entry*.

Depending on the function selected, the following additional settings may be possible:

- Map display ⇒ *page 214*.
- Map colors ⇒ *page 214*.
- Map orientation ⇒ *page 214*.
- Automatic zoom ⇒ *page 215*.

### Navigation view with route guidance started

Applies to: vehicles with navigation system and Audi virtual cockpit



Fig. 167 Standard map when route guidance is active (Audi virtual cockpit)

Requirement: a destination must be entered ⇒ *page 204*, route guidance must be started and the navigation tab must be displayed.

Depending on the vehicle equipment and the selected view ⇒ *page 14*, the following information will be displayed in the driver information system:

- ① Map content (such as points of interest)
- ② Current vehicle position

③ A bar graph appears when there is an upcoming turn. The fewer bars are shown, the shorter the distance is until the turn. If there is not an upcoming turn, the distance to the destination/stopover and the calculated arrival time is displayed in the right speedometer.

④ Name of the street where you are currently driving

**Map view with route guidance started**

Applies to: vehicles with navigation system and map view

Depending on the vehicle equipment, you can also have the active route guidance display in the map view\* in the driver information system.



Fig. 168 Diagram: map when route guidance has started (analog instrument cluster)

Requirement: a destination must be entered ⇒ page 204, route guidance must be started and the navigation tab must be displayed.

Depending on vehicle equipment, the following information may be shown in the driver information system.

- ① Distance to the destination or stopover
- ② Distance to the next maneuver
- ③ Display of the road that is currently being traveled or the road that you will turn onto during the next maneuver
- ④ Map content such as points of interest or traffic information

**Zooming in/out on the map (Zoom):** when a map is displayed, turn the left thumbwheel down/up to zoom in/out on the map.

**Street view with route guidance started**

Applies to: vehicles with navigation system and street view

Depending on the vehicle equipment, the active route guidance will be displayed in the street view\* in the driver information system.

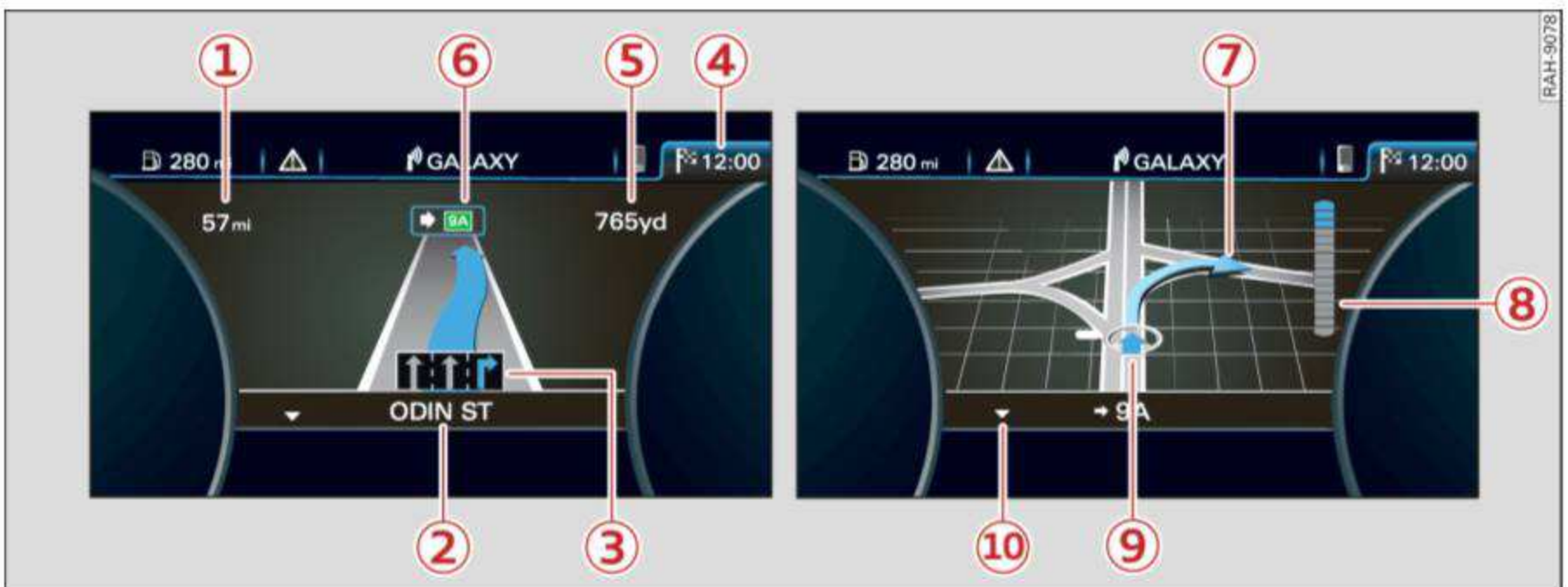

Fig. 169 Example: display of a turn in the street view (analog instrument cluster)

## Multifunction steering wheel

Requirement: a destination must be entered  
⇒ *page 204*, route guidance must be started and the navigation tab must be displayed.

Depending on vehicle equipment, the following information may be shown in the driver information system ⇒ *fig. 169*:

- ① Distance to the destination or stopover
- ② Displaying an expressway, highway or main road as preparation for an upcoming change in direction
- ③ Lane recommendation
- ④ Calculated arrival time
- ⑤ Distance to the next maneuver
- ⑥ Display of the expressway, highway or main road onto which you will be turning
- ⑦ Direction arrow for the upcoming maneuver
- ⑧ A bar graph appears when a direction arrow is displayed. The fewer bars are shown, the shorter the distance is until the turn.
- ⑨ Current vehicle position
- ⑩ Additional information (on-board computer)

The following functions are also available when route guidance is active:

- **Changing the voice guidance volume:** turn the right thumbwheel up or down during voice guidance.

### **WARNING**

The route calculated by the navigation system is a recommendation for reaching your destination. Obey traffic lights, stopping restrictions, one-way streets, lane change restrictions, etc.

### **Tips**

- Also see the chapter ⇒ *page 8, Controls at a glance*.
- An exclamation point “!” in front of the street name indicates that the information about this street or this section of the route is not complete in the navigation data contained in the MMI. Obey traffic laws in one-way streets and pedestrian zones.

## Arrow view with route guidance started

Applies to: vehicles with navigation system and arrow view

Depending on the vehicle equipment, the active route guidance will be displayed in the arrow view\* in the driver information system.

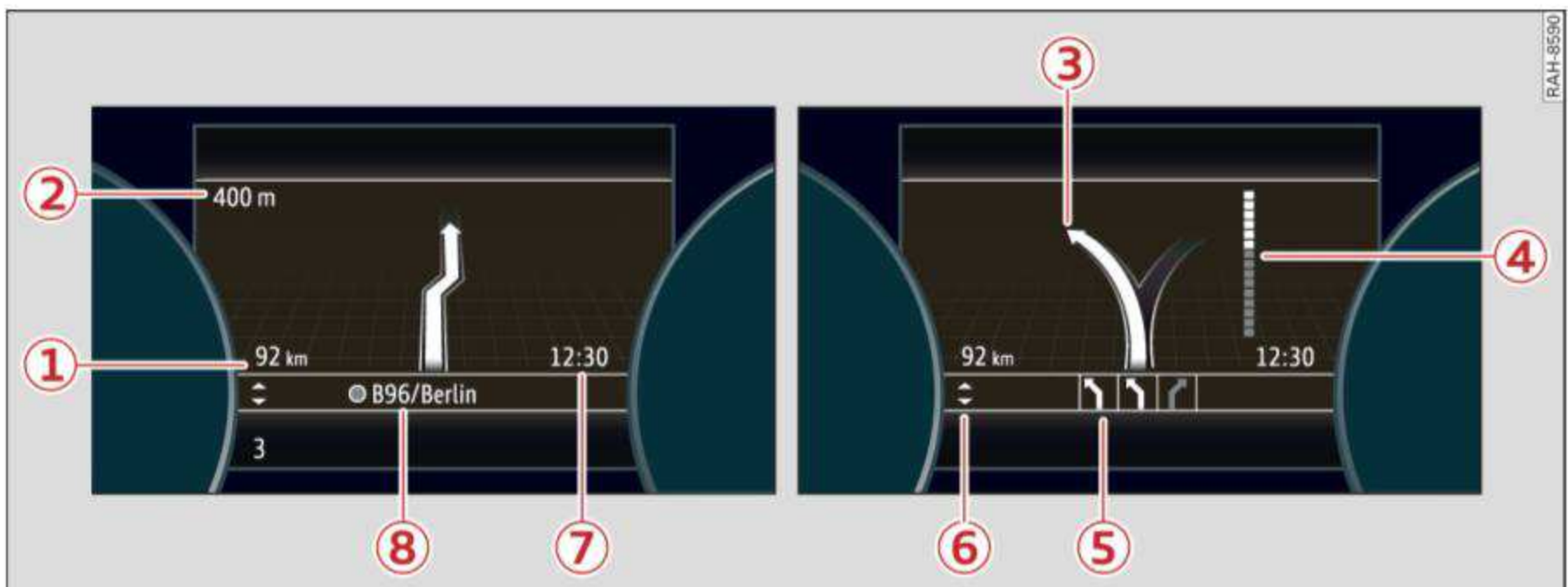

Fig. 170 Example: arrow view (monochrome instrument cluster)

Requirement: a destination must be entered  
⇒ *page 204*, route guidance must be started and the navigation tab must be displayed.

Depending on vehicle equipment, the following information may be shown in the driver information system ⇒ *fig. 170*:

- ① Distance to the destination or stopover

- ② Distance to the next maneuver
- ③ Direction arrow for the upcoming maneuver
- ④ A bar graph appears when a direction arrow is displayed. The fewer bars are shown, the shorter the distance is until the turn.
- ⑤ Lane recommendation
- ⑥ Additional information (on-board computer)
- ⑦ Calculated arrival time
- ⑧ Display of the street currently being driven on  
If a point is displayed before the street, it is indicating the street you will be on with the next maneuver.

The following functions are also available when route guidance is active:

- **Changing the voice guidance volume:** turn the right thumbwheel up or down during voice guidance.



#### WARNING

The route calculated by the navigation system is a recommendation for reaching your destination. Obey traffic lights, stopping restrictions, one-way streets, lane change restrictions, etc.



#### Tips

- Also see the chapter ⇒ *page 8, Controls at a glance*.
- An exclamation point “!” in front of the street name indicates that the information about this street or this section of the route is not complete in the navigation data contained in the MMI. Obey traffic laws in one-way streets and pedestrian zones.

GLOBAL COMMANDS		
<ul style="list-style-type: none"> <li>• Telephone</li> <li>• Audi connect</li> <li>• Navigation</li> <li>• Directory</li> <li>• Radio</li> <li>• Media</li> <li>• Sound</li> <li>• Help</li> <li>• Help Speech dialog system</li> <li>• Help Telephone</li> <li>• Help Audi connect</li> <li>• Help Navigation</li> <li>• Help Map</li> <li>• Help Radio</li> <li>• Help Media</li> </ul>	<ul style="list-style-type: none"> <li>• Favorites</li> <li>• Call (XY)</li> <li>• Enter number</li> <li>• Redial</li> <li>• Read new text message</li> <li>• Navigate to (XY)</li> <li>• Enter address/destination</li> <li>• Online destinations</li> <li>• Cancel route guidance</li> <li>• Map</li> <li>• Line (XY)</li> <li>• Next page / previous page</li> <li>• Cancel</li> <li>• No, I meant (XY)</li> <li>• Correction</li> </ul>	
TELEPHONE		
<ul style="list-style-type: none"> <li>• Enter number                             <ul style="list-style-type: none"> <li>• Delete number / correction</li> </ul> </li> <li>• Directory</li> <li>• Call (XY)                             <ul style="list-style-type: none"> <li>• business / private / land line / mobile</li> </ul> </li> </ul>	<ul style="list-style-type: none"> <li>• Call list</li> <li>• Redial</li> <li>• Call mailbox</li> <li>• Telephone favorites</li> </ul>	
NAVIGATION		
<ul style="list-style-type: none"> <li>• Navigate to (XY)</li> <li>• Start / cancel route guidance</li> <li>• Directory</li> <li>• Last destinations</li> <li>• Navigation favorites</li> <li>• Drive home</li> <li>• Enter address</li> <li>• Enter country / town / street / state</li> <li>• Exclude route / Exclude route for (XY) km / m</li> </ul>	<ul style="list-style-type: none"> <li>• Block route for (XY) miles / Block the next section</li> <li>• Route list</li> <li>• Calculate alternative routes</li> <li>• Online destinations</li> <li>• Special destination</li> </ul>	
MAP		
<ul style="list-style-type: none"> <li>• Map</li> <li>• Day map / Night map</li> <li>• 2D driving position map / 2D north position map / 3D map / Destination map / Overview map</li> </ul>		
AUDI CONNECT		
<ul style="list-style-type: none"> <li>• Audi connect</li> <li>• Travel information / Parking information</li> <li>• Fuel prices</li> <li>• Weather</li> </ul>	<ul style="list-style-type: none"> <li>• Flight information</li> <li>• City events</li> <li>• Online news</li> <li>• Twitter</li> </ul>	
RADIO	MEDIA	
<ul style="list-style-type: none"> <li>• Radio presets</li> <li>• FM</li> <li>• FM / AM / SIRIUS XM</li> <li>• Station (XY) / Frequency (XY)</li> <li>• Traffic announcement on / off</li> </ul>	<ul style="list-style-type: none"> <li>• Jukebox</li> <li>• CD / DVD</li> <li>• SD card 1 / SD card 2</li> <li>• Audi music interface / iPod / USB / Bluetooth / Wi-Fi / Medium (XY)</li> <li>• Media favorites / Artists / Albums / Genres / Tracks / Playlists / Videos</li> <li>• Folder up</li> <li>• Random playback on / off</li> </ul>	 

Fig. 171 Command overview





## Voice recognition system

### Operating

Applies to: vehicles with voice recognition system

*You can operate many Infotainment functions conveniently by speaking.*

Requirement: the ignition and the MMI must be switched on ⇒ *page 148*, there must not be any phone call in progress and the parking system must not be active.

- ▶ **Switching on:** press the  button   
⇒ *page 14*, *fig. 11* or ⇒ *page 15*, *fig. 13* briefly on the multifunction steering wheel and say the desired command after the **Beep**.
- ▶ **Switching off:** press and hold the  button.  
**Or:** press the  button.
- ▶ **Pausing:** say the command **Pause**. To resume, press the  button.
- ▶ **Correcting:** say the command **Correction**. **Or:** simply say a new command during an announcement ⇒ *page 245*.

#### Input assistance

The system guides you through the input with visual and audio feedback.

- **Visual input assistance:** after switching on voice recognition, a display with a selection of possible commands appears. This command display can be switched on or off. Select:  button > **Settings** > left control button > **MMI settings** > **Speech dialog system**.
- **Audio input assistance:** to have the possible commands read, turn the voice recognition system on and say **Help**.

#### For the system to understand you:

Speak clearly and distinctly at a normal volume. Speak louder when driving faster.

Emphasize the words in the commands evenly and do not leave long pauses.

Close the doors, the windows and the sunroof\* to reduce background noise. Make sure that passengers are not speaking when you are giving a voice command.

Do not direct the vents toward the hands-free microphone, which is in the roof headliner near the front interior lights.

Only use the system from the driver's seat because the hands-free microphone is directed toward that seat.

#### Additional settings

See ⇒ *page 245*, **Speech dialog system**.

#### WARNING

- Direct your full attention to driving. As the driver, you have complete responsibility for safety in traffic. Only use the functions in such a way that you always maintain complete control over your vehicle in all traffic situations.
- Do not use the voice recognition system in emergencies because your voice may change in stressful situations. It may take longer to dial the number or the system may not be able to dial it at all. Dial the emergency number manually.

#### Tips

- The dialog pauses when there is an incoming phone call and will continue if you ignore the call. The dialog ends if you answer the call.
- You can select an item in the list using either the voice recognition system or the control knob.

## Command overview information

Applies to: vehicles with voice recognition system

The following overviews describe the commands that can be used to operate the MMI using the voice recognition system.

Alternative commands are separated using a “/”, for example say: **Telephone** / (or) **Navigation** / (or) **Radio**.

Sequences of commands used to perform an action are identified with a “>”, for example say: **Enter address** > (then) **Enter country/state**. ▶

## Voice recognition system

The majority shown are main commands. This system also recognizes synonyms in certain cas-

es. For a **Business address**, you can also say **business, work, office** or **at the office**.

## Commands

### Global commands

Applies to: vehicles with voice recognition system

You can always use the global commands, regardless of the menu selected.

Function	Say:
Opening a menu	<b>Telephone / Directory / Navigation / Radio / Media / Audi connect* / Car / Tone</b>
Having the possible commands read aloud	<b>Help / Help speech dialog system / Help Telephone / / Help Navigation / Help Map / Help Radio / Help Media / Help Audi connect*</b>
Telephone functions	<b>Call (XY), for example, Call "John Smith" / Enter number / Redial / Directory / Read out new text message / Read out new e-mail</b>
Navigation functions*	<b>Drive me to (XY) or Navigate to (XY), for example Navigate to John Smith / Enter address / Cancel route guidance / Map / Online destinations* / Online destination (XY)*</b>
Accessing favorites	<b>Favorites &gt; follow the system prompts</b>
Selecting an entry from a list	<b>Line (XY)</b>
Scrolling through a list	<b>Next page / Previous page</b>
Correcting the command given	<b>Correction</b>
Switching the voice recognition system off	<b>Cancel</b>

### Telephone

Applies to: vehicles with voice recognition system and telephone

Requirement: a cell phone must be connected to the MMI ⇒ *page 174* and the **Telephone** menu must be open ⇒ *table on page 168*.

Depending on the vehicle equipment and the selected menu item, you can say the following commands:

Function	Say:
Calling a contact from the directory	<b>Call (XY), for example Call "John Smith"</b>
Selecting a specific contact number	<b>Call (XY) business / private / landline / cell phone, for example, Call "John Smith" private</b>
Selecting a phone number with an address card open	<b>Call / Call work / Call private / Call landline / Call cell phone work</b>
Calling a contact from your favorites list	<b>Telephone favorites &gt; after being prompted, say the desired contact &gt; Dial</b>
Displaying the call list	<b>Call list</b>

Function	Say:
Calling the last number dialed	<b>Redial</b>
Dialing a phone number	<b>Enter number</b> > after being prompted, say the telephone number in groups of individual numbers, for example. <b>888 555 1212</b> > <b>Dial</b>
Correcting the phone number that was entered	<b>Correction / Delete number</b>
Showing contact information	<b>Directory</b> > say the desired contact when prompted, for example <b>John Smith</b>
Listening to messages	<b>Call voicemail</b>
Entering the PIN (SIM)	<b>Enter PIN</b> > when prompted, say the PIN in individual numbers > <b>Save</b>
Correcting the PIN entry	<b>Correction / Delete PIN</b>
Correcting data input	<b>No I meant (XY)</b>
Closing the full-screen command list	<b>Close</b>

### Tips

- Contacts in the directory can be selected using the full name (“first name last name” and “last name, first name”) as well as with only the first or last name. This applies to cell phones that transmit names separated into first and last names.

- Please note that commands can only be given for the primary phone\* ⇒ *page 174*.
- For more information on supported cell phones, visit [www.audiusa.com/bluetooth](http://www.audiusa.com/bluetooth) or contact an authorized Audi dealer or authorized Audi Service Facility.

## Audi connect (Infotainment)

Applies to: vehicles with voice recognition system and Audi connect (Infotainment)

Requirement: the requirements for Audi connect (Infotainment) must be met ⇒ *page 187*.

Function	Say:
Accessing Audi connect Infotainment services	<b>Audi connect</b> > follow the system prompts
Audi connect Infotainment services	<b>Weather / Online news / Fuel prices / Parking information / Travel information / Twitter / Online traffic information / City Events / Flight information</b>
Search areas for Audi connect Infotainment services	<b>Near destination / Nearby / In a new city</b>
Correcting data input	<b>No I meant (XY)</b>

### Tips

Always read the chapter ⇒ *page 194*, *Audi connect (Infotainment) general information*.

## Voice recognition system

### Messages (Audi connect (Infotainment))

Applies to: vehicles with voice recognition system and Audi connect (Infotainment)

**Requirement:** a cell phone with an active MAP (Message Access Profile) must be connected to the MMI ⇒ *page 180*.

Function	Say:
Text editing commands	<b>Read out / Add / Delete / Record everything again / Replace with (XY) / Add recipient / Send</b>
Reading out a new message	<b>Read out new text message / Read out new e-mail</b>
Reading a message	<b>Read out text message / Read out e-mail</b>
Replying to the open text message	<b>Reply</b>
Forwarding the open text message	<b>Forward &gt; Add recipient / Insert template / Send</b>
Correcting data input	<b>No I meant (XY)</b>

#### Tips

– For more information on supported cell phones, visit [www.audiusa.com/bluetooth](http://www.audiusa.com/bluetooth) or contact an authorized Audi dealer or authorized Audi Service Facility.

– Always read the chapter ⇒ *page 194, Audi connect (Infotainment) general information*.

### Navigation

Applies to: vehicles with voice recognition system and navigation system

**Requirement:** the **Navigation** menu must be open ⇒ *table on page 168*.

Depending on the vehicle equipment and the selected menu item, you can say the following commands to enter a destination:

Function	Say:
Opening the list of previous navigation destinations	<b>Last destinations</b>
Accessing favorites	<b>Navigation favorites</b>
Selecting the home address	<b>Home address</b> or <b>Drive home</b>
Entering an address with guidance from the system	<b>Enter address</b> > <i>follow the system prompts</i>
Individual commands for entering a destination	<b>Enter country/state / Enter city / Enter ZIP code / Enter street / Enter house number</b>
Making a correction while entering a destination	<b>Correction</b>
Navigating to a contact	<b>Drive me to (XY)</b> or <b>Navigate to contact</b> , for example <b>Drive me to "John Smith"</b>
Navigating to a specific address for a contact	<b>Navigate to contact (XY) business / private</b> , for example "Navigate to John Smith private"
Navigating to favorites	<b>Navigation favorites &gt; Line (XY) / Line contents &gt; Start route guidance when prompted</b>

Function	Say:
Starting route guidance with an address card open	<b>Navigate / Navigate to private address / Navigate to business address</b>
Entering a new destination/stop-over when route guidance is active	<b>Enter address</b> > <i>enter the desired address when prompted</i> > <i>confirm the new destination/stopover if prompted</i>
Starting route guidance after entering a destination	<b>Start route guidance</b>
Canceling current route guidance	<b>Cancel route guidance</b>
Calculating alternative routes	<b>Calculate alternative routes</b>
Entering a point of interest by selecting a search area with guidance from the system	<b>Point of interest</b> > <b>Change search area</b> > <i>category or subcategory when prompted, for example "restaurant"</i>
Destination input categories	<b>Audi Service / Train station / Airport / Hotel / Hospital / Parking / Rest area / Restaurant / Gas station etc.</b>
Search areas for entering points of interest	<b>Nearby / Along route / Near destination / Near stopover / In a new city / In a new country/state</b>
Entering an online destination*	<b>Online destination (XY)</b> , for example <b>"Online destination "Lakeview Hotel" "</b>
Correcting data input	<b>No I meant (XY)</b>
Closing the full-screen command list	<b>Close</b>

Requirement: you must be in the **Navigation** or **Map** menu. Depending on the vehicle equipment and the selected menu item, you can say the fol-

lowing commands for additional settings in navigation:

Function	Say:
General map options	<b>Map / Day map / Night map / Automatically change map color</b>
Map type	<b>2D heading up map / 2D north up map / 3D map / Destination map / Overview map / Standard map* / Google Earth map<sup>a)b)</sup></b>
Showing the route list	<b>Route list</b>
Showing the remaining distance/time when route guidance is active	<b>Destination information</b>
Speed limit prompt	<b>How fast can I drive here?</b>
Setting voice guidance for active route guidance	<b>Voice guidance on / Voice guidance off / Voice guidance shortened / Voice guidance complete / Voice guidance traffic</b>
Blocking a certain section on the route	<b>Block route for (XY) meters/kilometers/yards/miles / Block next route / Avoid next section of route</b>

a) Provider at time of printing.

b) AUDI AG provides access to services from third party providers. Permanent availability cannot be guaranteed, because that depends on the third party provider.

### Tips

– Destinations may have to be spelled when entered, depending on which region you are

in and which menu language you have selected. ►

## Voice recognition system

– Always read the chapter ⇒ page 194, *Audi connect (Infotainment) general information*.

### Radio

Applies to: vehicles with voice recognition system

Requirement: the **Radio** must already be open.

Depending on the vehicle equipment and the selected frequency band, you can say the following commands:

Function	Say:
Selecting the frequency band	<b>FM*</b> / <b>SiriusXM*</b> / <b>FM</b> / <b>AM</b>
Selecting a station from the station list	<b>Channel (XY)</b> / <b>Frequency (XY)</b>
Selecting a station from favorites/presets	<b>Radio presets &gt; Line (XY)</b>
Setting the frequency	<b>Frequency (XY)</b> / <b>Frequency (XY) HD 1</b>
Correcting data input	<b>No I meant (XY)</b>
Closing the full-screen command list	<b>Close</b>

### Media

Applies to: vehicles with voice recognition system

Requirement: you must be in the **Media** menu.

Depending on the vehicle equipment and the active media, you can say the following commands:

Function	Say:
Selecting a source directly	<b>Jukebox*</b> / <b>CD</b> / <b>DVD</b> / <b>SD card 1</b> / <b>SD card 2</b> / <b>Audi music interface*</b> / <b>iPhone*</b> / <b>USB*</b> / <b>Bluetooth*</b> / <b>Wi-Fi*</b> / <b>Medium (XY)</b> , for example "John's player"
Selecting audio/video* files in the Jukebox*	<b>Media favorites</b> / <b>Artists</b> / <b>Albums</b> / <b>Genres</b> / <b>Tracks</b> / <b>Playlists</b> / <b>Videos</b>
Selecting audio files on an iPod (source: Audi music interface*)	<b>Artists</b> / <b>Albums</b> / <b>Genres</b> / <b>Tracks</b> / <b>Playlists</b> / <b>Composers</b> / <b>Podcasts</b> / <b>Audio books</b>
Navigating within a folder structure/list	<b>Folder up</b> / <b>Line (XY)</b>
Selecting shuffle	<b>Shuffle on</b> / <b>Shuffle off</b>
Correcting data input	<b>No I meant (XY)</b>
Closing the full-screen command list	<b>Close</b>

#### Note

Always follow the information found in ⇒  in *Wi-Fi hotspot on page 194*.

### External voice operation

Applies to: vehicles with voice recognition system and external voice operation

Requirement:



The ignition and the MMI must be switched on.

No phone call is in progress.

The parking aid as well as the Audi voice recognition system must not be active.

A cell phone must be connected to the MMI with the **Handsfree** profile ⇒ *page 174*.

The cell phone being connected must have voice control that can be controlled externally.

- ▶ **Switching on:** press and *hold* the  button on the multifunction steering wheel\* and say the desired command after the external speech dialog begins.
- ▶ **Continuing/resuming the dialog:** the system remains ready to use for a short time after ending the dialog. You can start a new external dialog during this time. Press the  button if needed, and say a new command. **Or:** select and confirm **Resume** on the MMI control panel.
- ▶ **Switching off:** press and hold the  button. **Or:** select and confirm **Cancel** on the MMI control panel.

### Tips

- There are no voice guidance\* prompts when a dialog is active.
- This function depends on the cell phone used. You can obtain more information from your cell phone service provider or from your cell phone user guide.
- AUDI AG simply provides access to control your cell phone with voice operation and does not take any responsibility for the contents and commands within the external voice control.

# Telephone

## Introduction

Applies to: vehicles with telephone

To make phone calls in your vehicle using the MMI, connect your cell phone to the MMI via Bluetooth.

### Handsfree

After you have connected your cell phone to the MMI via Bluetooth, you can use the handsfree system and operate telephone functions through your MMI. You can make calls using the antenna on your cell phone.

### WARNING

- Medical experts warn that cell phones can interfere with the function of pacemakers. Always maintain a minimum distance of about 8 inches (20 cm) between the cell phone antenna and the pacemaker.
- Do not carry the cell phone in a pocket directly over the pacemaker when the phone is switched on.
- Switch the cell phone off immediately if you suspect it may be interfering with the pacemaker.
- Do not use the voice recognition system\* ⇒ *page 167* in emergencies because your voice may change in stressful situations. It may take longer to dial the number or the system may not be able to dial it at all. Dial the emergency number manually.
- Switch your cell phone off in areas where there is a risk of an explosion. These locations are not always clearly marked. This may include gas stations, fuel and chemical storage facilities or transport vehicles, or locations where fuel vapors (such as propane or gasoline vapor in vehicles or buildings), chemicals or large quantities of dust particles (such as flour, sawdust or metal) may be present in the air. This also applies to all other locations where you would normally turn your vehicle engine off.
- The demands of traffic require your full attention. Always read the chapter ⇒ *page 147, Traffic safety information.*

### Note

Always follow the information found in ⇒  in *Wi-Fi hotspot on page 194.*

### Tips

- The Bluetooth connection range is limited to inside the vehicle. It can also be affected by local conditions and interference with other devices.
- To learn which Bluetooth connections and which of the functions in your cell phone are supported, check with your cell phone service provider or the database for mobile devices at [www.audiusa.com/bluetooth](http://www.audiusa.com/bluetooth).

## Setup

### Connecting a cell phone using Bluetooth

Applies to: vehicles with telephone

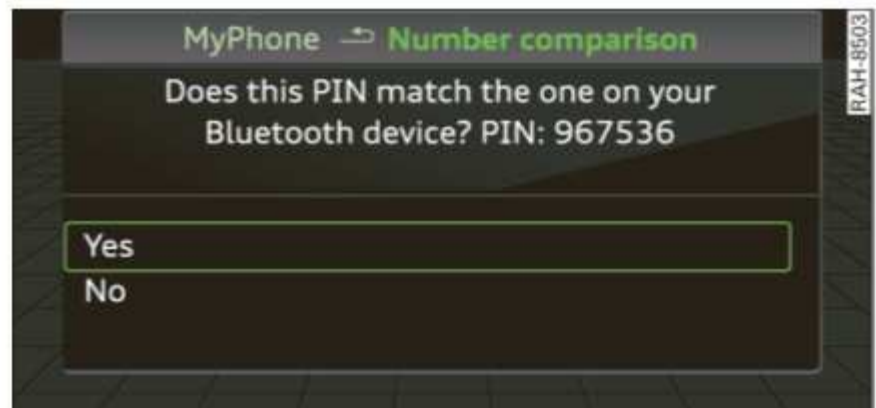

Fig. 172 Displaying the PIN for entering in the cell phone

### Requirement

The vehicle must be stationary and the ignition must be switched on.

The Bluetooth settings must be open on your cell phone during the connection setup.

The Bluetooth function and visibility of the MMI ⇒ *page 248* and cell phone must be switched on.

The cell phone to be connected must not be connected to any other Bluetooth device.

The MMI must not be connected to a cell phone.

### Connecting a cell phone

- ▶ Select: **MENU** button > **Telephone** > **Connect mobile device** > **Find new devices** > **Next**. The available Bluetooth devices are shown in the Infotainment system display. **Or** select: **MENU** ▶

button > **Settings** > left control button > **MMI settings** > **Connection manager** ⇒ *page 246*.

- ▶ Select and confirm the desired cell phone from the list of displayed Bluetooth devices.
- ▶ The MMI generates a PIN for the connection setup ⇒ *fig. 172*.
- ▶ Select and confirm **Yes**.
- ▶ Enter the PIN for connecting on your cell phone. **Or:** when the PIN is displayed on your cell phone, confirm the PIN on your cell phone and in the MMI. The time allowed for entering the PIN is limited to approximately 30 seconds.
- ▶ Pay attention to any additional system prompts displayed on your cell phone, for example if the system should connect automatically in the future. Depending on the cell phone, you may have to confirm downloading the directory separately.

### After connecting successfully

After connecting successfully, information about the connected profiles will appear. You can also change the profiles later. Select: **MENU** button > **Settings** > left control button > **MMI settings** > **Connection manager** ⇒ *page 246*.

In addition, the cell phone contacts are automatically loaded in the MMI directory. This process can take several minutes, depending on the number of contacts.

You can also make your connected cell phone the default phone by selecting **Set as default telephone** in the **Connection manager** ⇒ *page 248*.

#### Note

Always follow the information found in ⇒  in *Wi-Fi hotspot on page 194*.

#### Tips

- Making phone calls through the MMI is only possible using the **Handsfree** Bluetooth profile.
- You can apply additional settings to connected mobile devices using the **Connection manager** ⇒ *page 246*.
- You can also search for the MMI in your cell phone using the Bluetooth device search.

- You only have to pair your device one time. Bluetooth devices that are already paired automatically connect to the MMI when the Bluetooth function is switched on, they are within range and the ignition is switched on. The last connected cell phone is given first priority.
- Authorizing the MMI connection in your cell phone will make automatic connection possible.
- Pay attention to any system prompts displayed on your cell phone, for example if the system should connect automatically in the future. Depending on the cell phone, you may also need to download the directory and confirm access to your text messages separately.
- When leaving the vehicle, the Bluetooth connection to the cell phone will automatically disconnect. Depending on your cell phone, phone calls in progress may be automatically redirected from the MMI to your cell phone and you can continue the call on your phone.
- You can obtain more information from your cell phone service provider or from your cell phone user guide. For information on using the telephone, visit [www.audiusa.com/bluetooth](http://www.audiusa.com/bluetooth) or contact an authorized Audi dealer or authorized Audi Service Facility.
- Applies to: vehicles without secondary phone: Several cell phones can be paired to the MMI, but only one cell phone can be actively connected to the MMI.
- Applies to: vehicles without secondary phone: If a Bluetooth device is already connected to the MMI, it will be disconnected when another device connects to the MMI.

### Operating two telephones through the MMI

You can connect two cell phones to the MMI, for example your business cell phone as the primary phone and your private cell phone as the secondary phone. You can be reached in your vehicle through both cell phones.

The first connected cell phone is displayed as the primary phone in the MMI. The second cell phone is connected as the secondary phone.

The directory from the connected primary phone will always be displayed. If you would like to use the directory from the secondary phone, you must switch the primary and secondary phone ⇒ *page 176*.

#### Connecting a cell phone as the primary phone

Connect your cell phone to the MMI via Bluetooth. The first connected cell phone is displayed as the **Primary phone** in the MMI.

See ⇒ *page 174, Connecting a cell phone using Bluetooth*.

#### Connecting a cell phone as the secondary phone

Requirement: a cell phone must be connected to the MMI as the primary phone.

Select: **MENU** button > **Telephone** > right control button > **Connect secondary telephone**.

See ⇒ *page 174, Connecting a cell phone using Bluetooth*.

Example: you have connected your business cell phone to the MMI as the primary phone and your private cell phone as the secondary phone. To be able to call contacts from your private cell phone directory, you must switch the primary and secondary phone, since the directory from the primary phone is always displayed.

#### Switching the primary and secondary phone

Requirement: a primary phone and a secondary phone must be connected.

**Switch primary and second. phone:** select **MENU** button > **Telephone** > right control button > **Switch primary and second. phone**.

#### Tips

- Please note that only the directory from the primary phone is always displayed.
- You can see if a cell phone is connected as the primary phone or secondary phone in the **Connection manager** ⇒ *page 246*. **Or:** the device name of the connected primary phone is shown in the **Telephone** menu (such as myPhone).
- If the primary phone does not connect automatically to the MMI when the ignition is switched on, for example because it is out of the vehicle range or the Bluetooth function is switched off, then a previously paired secondary phone is automatically connected as the primary phone.
- You can send and receive messages on your primary phone as well as on your secondary phone ⇒ *page 177, fig. 173*. You do not need to switch your primary phone and secondary phone for this.
- You can also make your connected cell phone the default phone by selecting **Set as default telephone** in the **Connection manager** ⇒ *page 248*.

## Using the telephone

### Opening the telephone

Applies to: vehicles with telephone



Fig. 173 Example: telephone functions in selection menu



Fig. 174 Example: additional telephone functions in selection menu

Requirement: a cell phone must be connected to the MMI ⇒ *page 174*.

- ▶ Select: **MENU** button > **Telephone** > left control button.

The following phone functions are available ⇒ *fig. 173*/⇒ *fig. 174*:

① Call list .....	177
② Favorites .....	179
③ Directory .....	183
④ Enter number .....	177
⑤ Text message (myPhone)*/text message (secondary phone)* .....	180
⑥ E-mail (myPhone)*/e-mail (secondary phone)* .....	181

The device name for your cell phone is displayed in the **Telephone** menu, for example text message (myPhone) ⇒ *fig. 174*.

### Dialing a phone number

Applies to: vehicles with telephone

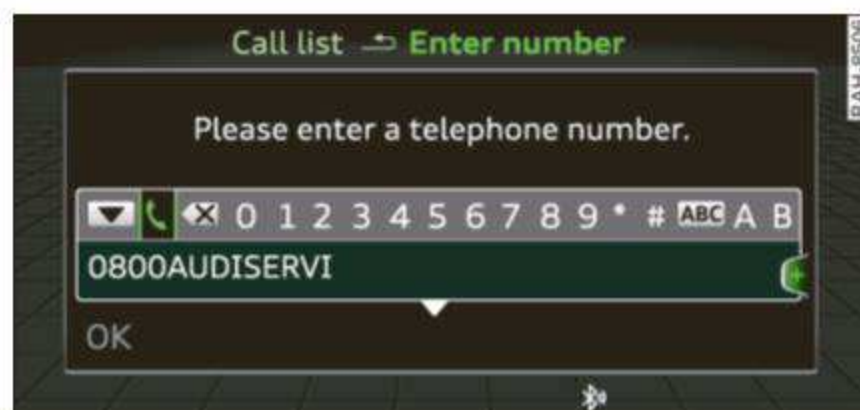

Fig. 175 Number speller



Fig. 176 Dialing a phone number from the call list

- ▶ Select: **MENU** button > **Telephone** > left control button.

### Call list

Requirement: the call list must contain a phone number.

Turn the control knob to display the call list.

Select and confirm the desired telephone number from the recent calls list.

Call list symbols ⇒ *fig. 176*:

- ① Missed calls
- ② Dialed numbers
- ③ Accepted calls

Select: *a contact from the list* > right control button.

- **Call**: call the selected contact.
- **Connect secondary telephone\*/Switch primary and second. phone\***: see ⇒ *page 176*.
- **Edit phone number before calling**: edit a phone number before dialing it. Select and confirm **OK** to edit. **Or**: press the left control button to return without editing.
- **Send text message**: write a text message to the selected contact.

## Telephone

- **Delete call list:** select and confirm if you would like to **Delete this entry** or **Delete all entries**.
- **Store as favorite:** store the selected contact as a favorite.
- **Show contact details:** see ⇒ page 183.
- **Connection manager:** see ⇒ page 246.
- **Bluetooth settings:** see ⇒ page 248.
- **Online settings:** see ⇒ page 248.
- **Wi-Fi settings:** see ⇒ page 193, *Wi-Fi hotspot*.
- **Telephone settings:** see ⇒ page 184.

### Favorites

Requirement: a phone number or contact must be stored as a favorite ⇒ page 179.

Select and confirm a favorite in the favorites list.

### Directory

Requirement: you must have at least one contact stored in your cell phone.

Select and confirm a phone number from the directory ⇒ page 183.

### Enter number

- **Entering a phone number as a sequence of numbers:** enter the number using the number speller ⇒ fig. 175.
- **Entering the phone number as a sequence of letters:** select and confirm  above the number speller. Enter a sequence of letters using the letter speller, for example *AUDISER-VICE*.
- **Dialing a phone number:** select and confirm . **Or:** push the control knob down. Select and confirm **OK**.
- **Deleting individual characters:** select and confirm .
- **Deleting all characters entered at once:** turn the control knob with the character selection to  and press and hold the control knob. **Or:** select the right control button > **Clear input field**.

### Accepting/ending a call

Applies to: vehicles with telephone

- **Accepting a call:** select and confirm **Answer**.
- **Declining a call:** select and confirm **Decline**.

- **Muting the active call:** select and confirm **Mute**.
- **Ending a phone call/cancel dialing:** select and confirm **End call**.

**Caller information:** the *name, phone number* or **Unknown** appears in the Infotainment system display depending on if the caller has been stored in the directory and if the phone number has been transmitted. A picture may also be displayed, depending on whether you have assigned a picture to a contact in your directory and if it was transferred to your MMI. You can find out if your cell phone supports this function from your cell phone network provider, your cell phone owner's manual or at [www.audiusa.com/bluetooth](http://www.audiusa.com/bluetooth).

### Tips

- The radio or media playback is muted during a phone call.
- Missed calls are displayed with a symbol in the status line of the Infotainment system display  ⇒ page 158, fig. 165.

### During a phone call

Applies to: vehicles with telephone

Requirement: there must be a call in progress.

- ▶ **End call:** you can end a phone call.
- ▶ **Send tone sequence:** you can enter tone sequences (**DTMF**) directly using the number speller and send to the other person on the call.
- ▶ **Other call options:** press the right control button.

The following options are possible during a call depending on the cell phone being used and the type of connection:

- Answering an additional call: if there is an incoming call while another call is active, you can select **Answer** to put the existing call on hold and answer the incoming call. If you select **Decline**, the incoming call will be declined.
- Accepting an incoming call when there is an active call and a call on hold: select **Replace**. The active call is replaced with the incoming call. ▶

- Muting the incoming call: select and confirm **Mute**.
- **Additional call**: select: **Find contact** > **Call list/Directory/Favorites** > *an entry from the list*.

**Mute**: if you select and confirm this function, the other person on the phone cannot hear you. You can hear the other person. To turn the microphone back on, select and confirm **Unmute**.

**Hold call/Resume held call**: you can place the existing call on hold and resume it again. To resume the call, select and confirm the call you would like to resume.

**Transfer call to mobile device\***: select and confirm **Transfer call to mobile device** to transfer the existing call from the MMI to your cell phone.

**Switch to hands-free mode\***: Requirement: you must have a phone call in progress on your cell phone. Select and confirm **Switch to hands-free mode** to transfer the call from your cell phone back to the MMI.

**Swap call**: alternate between two phone calls while one of the calls is on hold. Selecting **End call** will end the active phone call. A phone call on hold can be resumed using the right control button > **Resume**.

**Connection manager**: see ⇒ page 246.

**Telephone settings**: see ⇒ page 184.

### Tips

- To be notified of an incoming call during a phone call, the *call waiting* function in your cell phone must be switched on when using the **Handsfree** profile.
- You can obtain more information from your cell phone service provider or from your cell phone user guide.
- When leaving the vehicle, the Bluetooth connection to the cell phone will automatically disconnect. Depending on your cell phone, phone calls in progress may be automatically redirected from the MMI to your cell phone and you can continue the call on your phone.
- The display of an incoming phone call in the Infotainment system display may still be

visible for a few seconds after a call is answered/ignored depending on the cell phone in use.

### Making an emergency call

Applies to: vehicles with telephone

- ▶ Select: **MENU** button > **Telephone** > left control button > **Enter number** > Enter emergency call number (for example, 911) > **OK**.

### WARNING

- Because your phone works with radio signals, a connection cannot be guaranteed under all circumstances. Do not rely on only your phone when it comes to essential communication (such as a medical emergency).
- Always follow the instructions given by the emergency personnel during an emergency call and only end the call when they instruct you to do so.

### Tips

Emergency numbers are not the same everywhere. Find out which emergency number is used in your current location.

## Favorites

Applies to: vehicles with telephone

*Up to 50 contacts, in addition to the voicemail number, can be stored in any order in the favorites list.*

- ▶ Select: **MENU** button > **Telephone** > left control button.

### Storing an existing phone number as a favorite:

- Select and confirm **Call list/Directory**.
- Select a contact or phone number from the list.
- Select: right control button > **Store as favorite**.
- Enter a name for the favorite or select a suggestion.
- Select and confirm **Save**.

### Renaming stored favorites

- Select: **Favorites** > *a favorite from the list*. ▶

## Telephone

- Select the right control button > **Rename favorite**.

### Moving stored favorites

- Select: **Favorites** > *a favorite from the list*.
- Select the right control button > **Move favorite**.
- Select and confirm the location of the selected favorite.

### Deleting a stored favorite

- Select: **Favorites** > *a favorite from the list*.
- Select the right control button > **Delete favorite** > **Delete this favorite** or **Delete all favorites**.

## Messages

### Text messages

Applies to: cell phones with Bluetooth Message Access Profile (MAP)

*Depending on the cell phone being used and the cell phone network contract, you can receive and send text messages using the MMI.*

### Requirement

A cell phone must be connected to the MMI via Bluetooth MAP (Message Access Profile)

⇒ *page 174*.

- ▶ Select: **MENU** button > **Telephone** > left control button > **text message (myPhone)/text message (secondary phone)\***.

### Write new text message

Select and confirm **Write new text message**.

- **Using a template**: select and confirm the desired template from the list.
- **Writing your own text\***: select and confirm **Do not use template**. Enter text using the MMI touch control pad\* or the letter speller.
- Enter one or more recipients.
- Select and confirm **Send**.

### Inbox

Displays all received text messages.

### Sent

Displays all sent text messages.

### Outbox

Displays all text messages to be sent.

### Drafts

Displays all text messages that have not yet been sent and stored text messages.

### Tips

- Please note that you may have to activate the receiving and sending of text messages depending on the SIM card being used in your cell phone (for example, when using a multi-SIM). You can obtain more information from your cell phone service provider or from your cell phone user guide.
- For more information on supported cell phones, visit [www.audiusa.com/bluetooth](http://www.audiusa.com/bluetooth) or contact an authorized Audi dealer or authorized Audi Service Facility.
- You need a cell phone with Message Access Profile that also supports the sending function to be able to send text messages through the MMI.

### Message options

Applies to: cell phones with Bluetooth Message Access Profile (MAP)

- ▶ Select: **TEL** button > left control button > **text message (myPhone)/text message (secondary phone)\*** > **Inbox/Sent/Outbox** > right control button.

The following options may be available depending on the selected menu.

### Storing a text message as a template

Ten text message templates are stored in the MMI. You can save up to ten additional templates.

- Create a text message.
- Select and confirm **Store as template**.

### Resume last text message

The last edited text message can be resumed.

### Reply\*

A reply can be sent for the selected message in the **Inbox**.

## Forward

The selected text message can be forwarded to a different recipient.

## Send again\*

The selected text message can be resent.

## Delete this text message\*

The selected text message can be deleted.

## Read out<sup>1)</sup>

You can have the MMI read an open text message.

## Text messaging settings\*

To display when a new text message is received, enable the **Text message notifications**. New text messages are indicated with an envelope  in the Infotainment system display status line.

## Connection manager

See ⇨ *page 246*.

## Wi-Fi settings

See ⇨ *page 193*.

## Telephone settings

See ⇨ *page 184*.

### Tips

Messages that are deleted in the MMI are also deleted in the cell phone automatically.

### E-mail\*

Applies to: cell phones with Bluetooth Message Access Profile (MAP)

*Depending on the type of cell phone being used, you can receive and send e-mails through the MMI.*

Requirement: a cell phone must be connected to the MMI via Bluetooth MAP (Message Access Profile) ⇨ *page 174*. You can find out in your cell phone owner's manual if your cell phone supports this function.

- ▶ Select: **MENU** button > **Telephone** > left control button > **e-mail (myPhone)/e-mail (secondary phone)\***.

## Write new e-mail

Select and confirm **Write new e-mail**.

- **Using a template**: select and confirm the *desired template from the list*.
- **Writing your own text\***: select and confirm **Do not use template**. Enter text using the MMI touch control pad\* or the letter speller.
- Enter one or more recipients.
- Select and confirm **Send**.

## Inbox

All received e-mails are displayed.

## Sent

All sent e-mails are displayed.

## Outbox

All e-mails that will be sent are displayed.

## Drafts

All saved e-mails that have not been sent yet are displayed.

### Note

Always follow the information found in ⇨  in *Wi-Fi hotspot on page 194*.

### Tips

- For more information on supported cell phones, visit [www.audiusa.com/bluetooth](http://www.audiusa.com/bluetooth) or contact an authorized Audi dealer or authorized Audi Service Facility.
- To ensure that your sent e-mails are received, connect your cell phone to the Wi-Fi hotspot\* in the vehicle so that the e-mail app on your cell phone continues to have Internet access. If you are still not receiving e-mails even though you have a successful connection, then contact your e-mail service provider or your cell phone service provider.

<sup>1)</sup> Not available in all languages.

### Message options

Applies to: cell phones with Bluetooth Message Access Profile (MAP)

- ▶ Select: **MENU** button > **Telephone** > left control button > **e-mail (myPhone)/e-mail (secondary phone)\*** > **Inbox/Sent/Outbox** > right control button.

The following options may be available depending on the selected menu.

#### Store as template

Ten e-mail templates are stored in the MMI. You can save up to ten additional templates.

- Create an e-mail.
- Select and confirm **Store as template**.

#### Resume last edited e-mail

The last e-mail in progress can be resumed.

#### Reply\*

A reply can be sent for the selected e-mail in the **Inbox**.

#### Reply to all\*

A reply can be sent for the selected e-mail in the **Inbox** and it will be sent to all of the entered recipients.

#### Forward

The selected e-mail can be forwarded to a different recipient.

#### Delete this message\*

The selected e-mail can be deleted.

#### Read out<sup>1)</sup>

You can have the MMI read an open e-mail.

#### E-mail settings\*

To display when a new e-mail is received, activate the **E-mail notifications**. New e-mails are indicated with an envelope  in the Infotainment system display status line.

#### Connection manager

See ⇨ *page 246*.

#### Wi-Fi settings

See ⇨ *page 193*.

#### Telephone settings

See ⇨ *page 184*.

#### Tips

- Messages that are deleted in the MMI are also automatically deleted in the connected cell phone.
- You cannot read any messages while driving.

## Listening to voicemail

Applies to: vehicles with telephone

- ▶ Select: **MENU** button > **Telephone** > left control button. Select and confirm **Call list/Directory/Favorites** > **Voicemail**.

- **Entering the voicemail number:** enter the desired number. Select and confirm **OK**.
- **Dialing the voicemail number:** select and confirm **Voicemail**.

#### Tips

- This service must be set up and activated in advance by the cell phone service provider. You can obtain more information from your cell phone service provider.
- The voicemail number depends on the cell phone service provider.

<sup>1)</sup> Not available in all languages.

## Directory

### Opening the directory

Applies to: vehicles with telephone

After connecting the cell phone, the contacts in it are automatically imported into the MMI.



Fig. 177 Directory

Requirement: you must have at least one contact stored in your cell phone.

- ▶ Select: **MENU** button > **Telephone** > left control button > **Directory**.
- **Calling a contact:** select and confirm a contact from the directory. The phone numbers for the selected contact are displayed. To make the call, select and confirm a phone number.
- **Free text search for a contact:** see ⇨ page 157.

Contacts are displayed in alphabetical order and can be sorted by first or last name ⇨ page 185, **Sort order**.

The directory can be opened through the **Telephone** menu as well as through the **Navigation\*** menu.

### **i** Tips

- Additional information on free text searches can be found under ⇨ page 157.
- Check for a possible request to synchronize on your cell phone. Requests to synchronize the directory must be confirmed so that your cell phone contacts can be loaded into the MMI.
- The contact display in the MMI depends on the cell phone used. For more information on supported cell phones, visit [www.audiusa.com/bluetooth](http://www.audiusa.com/bluetooth) or contact an authorized Audi dealer or authorized Audi Service Facility.

- Please note that only the directory from the primary phone\* is always displayed.
- The contacts from the cell phone may not be transferred in alphabetical order. If there are too many entries, contacts with different first letters may be missing in the MMI.
- The contacts in the local MMI memory are always visible and can be accessed by other users.

### Free text search for a contact

Applies to: vehicles with telephone

- ▶ Select: **MENU** button > **Telephone** > left control button > **Directory**.
- ▶ To limit the search, enter the initials of the contact being searched with each initial separated by a space in the input field. Enter additional letters if necessary.
- ▶ Select and confirm a contact from the directory. The phone numbers for the selected contact are displayed.
- ▶ To make the call, select and confirm a phone number.

### **i** Tips

- You can scroll through long lists quickly by turning the control knob quickly. The scrolling speed depends on the number of list entries.
- Additional information on free text searches can be found under ⇨ page 157.

### Showing contact details\*

Applies to: vehicles with telephone

You can show contact details depending on the vehicle equipment.



Fig. 178 Showing contact details

## Telephone

- ▶ Select: **MENU** button > **Telephone** > left control button.
  - ▶ Select and confirm **Directory** > *a contact from the directory*.
  - ▶ Select: right control button > **Show contact details**.
- **Calling:** select and confirm the desired telephone number.
- **Navigating:** to start navigation, select and confirm the desired address. Select and confirm **Start route guidance**.

Press the right control button to open additional options for the contact details.

### Add destination

To start navigation, select and confirm the desired address. Select and confirm **Start route guidance**.

### Store as favorite

See ⇒ *page 179, Favorites*.

### Send text message\*

You can send a text message ⇒ *page 180* to the selected contact.

### Delete contact

The selected contact can be deleted.

#### Tips

- Contacts edited in the MMI directory cannot be automatically updated in the connected cell phone. Audi recommends editing cell phone contacts directly in the cell phone.
- Only the contacts in the local MMI memory can be edited or deleted.

### Importing and exporting contacts

Applies to: vehicles with telephone

*Contacts in vCard format (.vcf) can be imported into the directory or exported.*

Requirement: an SD card must be inserted in one of the SD card readers\* ⇒ *page 226* or a USB storage device must be connected to the Audi music interface\* ⇒ *page 231* or the require-

ments for Audi connect Infotainment services\* must be met ⇒ *page 187*.

- ▶ Select: **MENU** button > **Telephone** > left control button > **Directory**.
  - ▶ Select: right control button > **Directory settings**.
- **Importing contacts from a storage device:** select and confirm **Import contacts** > **SD card 1/SD card 2** or **USB device 1/USB device 2** > *desired contacts* > **Start import**.
- **Exporting contacts to a storage device:** select and confirm **Export contacts** > **SD card 1/SD card 2** or **USB device 1/USB device 2** > *desired contacts* > **Start export**.
- **Selecting all contacts at once to import/export:** select and confirm **Import contacts/Export contacts** > **SD card 1/SD card 2** or **USB device 1/USB device 2** > **All** > **Start import/Start export**.

#### Tips

- Always read the chapter ⇒ *page 194, Audi connect (Infotainment) general information*.
- For additional information on the myAudi account, visit [www.audiusa.com/myaudi](http://www.audiusa.com/myaudi).
- The imported contacts are stored in the local memory of the directory.
- A maximum of 1,000 contacts can be imported. You can check the directory memory capacity at any time ⇒ *page 185*.
- Never save important data on memory cards or USB storage devices. Audi is not responsible for damaged or lost files and media.
- Contacts that were downloaded from a cell phone cannot be exported.
- There should be no other files or folders on the storage medium containing the contacts to be imported.

## Additional settings

### Telephone settings

Applies to: vehicles with telephone

- ▶ Select: **MENU** button > **Telephone** > right control button > **Telephone settings**.

## Call options\*

**Call forwarding:** you can switch the forwarding of incoming calls to your voicemail or to another phone number on and off. You can check if the function is activated or deactivated with **Check status**.

**Call waiting:** you are alerted to an incoming call during a phone call when the function is switched on . You can check if the function is activated or deactivated with **Check status**.

**Send own telephone number:** sending your phone number with an outgoing call can be activated and deactivated. With the **Network-dependent** setting, the setting listed in the contract with the cell phone service provider is used. The settings only apply to the **Telephone** menu in the MMI. Please note that the settings on your cell phone will apply after disconnecting the Bluetooth connection. You can check if the function is activated or deactivated with **Check status**.

## Ringtone and volume settings<sup>1)</sup>

Using the **Mute telephone** function, you can switch the ringtone playback through the MMI speaker on and off. You can play the ringtones using the **Ringtone** function. Select and confirm an entry from the list. For the **Ringtone volume/Message volume** settings, see *⇒ page 250*. The **Microphone input level** can be adjusted during a phone call using the control knob.

### Tips

- Several cell phones can be paired to the MMI, but only two\* cell phones can be actively connected.
- To delete all paired Bluetooth devices, the **Bluetooth** function can be reset to the factory default settings *⇒ page 246*.

## Additional options

- ▶ Select: **MENU** button > **Telephone** > right control button.

## Connection manager

See *⇒ page 246*.

## Bluetooth settings\*

See *⇒ page 248*.

## Online settings\*

See *⇒ page 248*.

## Wi-Fi settings\*

See *⇒ page 193, Wi-Fi hotspot*.

## Directory settings

Applies to: vehicles with telephone

- ▶ Select: **MENU** button > **Telephone** > left control button > **Directory** > right control button > **Directory settings**.

## Memory capacity

Shows the **Memory capacity** for the directory.

You can manage up to 17,000 contacts with the directory. You can load up to 4,000 contacts from your cell phone into each directory. You can also import up to 1,000 contacts from a storage device.

## Sort order

You can sort the contacts in your directory alphabetically according to **Last name** or **First name**.

## Import contacts/Export contacts

See *⇒ page 184*.

## Download directory

To update the contacts in the MMI, you can manually download your cell phone contacts. Depending on the cell phone, the Bluetooth connection may need to be disconnected and reconnected to update the contacts.

## Hide contacts without phone number

When this function is switched on, grayed-out contacts that have no phone numbers stored for them will be hidden in the directory.

<sup>1)</sup> Depends on the connected cell phone.

## Troubleshooting

Applies to: vehicles with telephone

Problem	Solution
<p><b>Pairing</b> the cell phone to the MMI failed.</p>	<p>Check if the requirements for connecting a cell phone are met ⇒ <i>page 174</i>. <b>Or:</b> check if you accidentally declined the connection setup PIN on your cell phone. If necessary, repeat the pairing process ⇒ <i>page 174</i>.</p>
<p>After pairing, <b>not all contacts/no contacts</b> are loaded in the MMI.</p>	<p>Avoid using special characters in names. Avoid using contact groups on your cell phone.</p>
<p>Certain <b>telephone functions</b> are grayed out or not available.</p>	<p>The telephone functions depend on the cell phone service provider and the cell phone you are using. You can obtain more information from your cell phone service provider, in your cell phone user guide or in the database for mobile devices at <a href="http://www.audiusa.com/bluetooth">www.audiusa.com/bluetooth</a>.</p>
<p>Some <b>telephone functions</b> are switched off or not available, even though the cell phone is supported.</p>	<p>On corporate phones, some Bluetooth settings may not be compatible or the cell phone Bluetooth function may be deactivated. You can obtain more information from your system administrator.</p>

## Audi connect (Infotainment)

### Introduction

Applies to vehicles with Audi connect (Infotainment)

With Audi connect Infotainment services, online information is transmitted directly to the vehicle and then integrated.

#### WARNING

To reduce the risk of an accident, only use Audi connect Infotainment services when road and traffic conditions permit. Always read and follow the notes in ⇒ *page 147, Traffic safety information.*

### Setup

#### Requirements for Audi connect (Infotainment)

Applies to vehicles with Audi connect (Infotainment)

The data connection for Audi connect Infotainment services is made through an embedded SIM card (eSIM card) that is equipped in the vehicle.

The following requirements must be met to use the embedded SIM card:

- You have already registered at [www.audiusa.com/myaudi](http://www.audiusa.com/myaudi) and assigned a vehicle.
- You have also already logged in to your myAudi account under **Audi connect plan** for the embedded SIM card and accepted the terms of use given there. For additional information, contact an authorized Audi dealer or authorized Audi Service Facility.

Then your Audi connect Infotainment services are activated and can be used in your vehicle.

#### Tips

- After the free subscription has ended or the data volume has been used up, data packets can be purchased for the use of Audi connect Infotainment services. You can find additional information about fees and purchasing at [www.audiusa.com/myaudi](http://www.audiusa.com/myaudi).

- Read this chapter before operating ⇒ *page 194, Audi connect (Infotainment) general information.*

## Configuration through myAudi

#### Audi connect (Infotainment) configuration

Applies to vehicles with Audi connect (Infotainment)

Some Audi connect Infotainment services must be configured through your personal myAudi account before using them for the first time.

- If you do not have a personal myAudi account yet, you can register online at [www.audiusa.com/myaudi](http://www.audiusa.com/myaudi).
- Add your vehicle to your myAudi account.
- Activate/configure the Audi connect (Infotainment) services you would like for your vehicle in your myAudi account.
- For some Audi connect Infotainment services, you may also have to enter your myAudi user data or your myAudi PIN when accessing services in the MMI to connect your vehicle to myAudi.

For detailed information on configuration, visit [www.audiusa.com/myaudi](http://www.audiusa.com/myaudi).

#### Logging into myAudi in the vehicle

Applies to vehicles with Audi connect (Infotainment)

*To use some Audi connect Infotainment services (such as Twitter\*), you must first connect your vehicle to myAudi to transfer your personal settings from your myAudi account.*



Fig. 179 Logging into myAudi

- ▶ Select: **MENU** button > **Audi connect** > right control button > **Log in.**

## Audi connect (Infotainment)

- ▶ Enter your myAudi user data. **Or:** enter your eight-digit myAudi PIN.
- ▶ Confirm your entry with **OK**.

Then you can open your personal settings from your myAudi account in your vehicle.

### Tips

You can receive your myAudi PIN if you have set up a myAudi account. For additional information, see [www.audiusa.com/myaudi](http://www.audiusa.com/myaudi).

## Opening Audi connect (Infotainment)

Applies to vehicles with Audi connect (Infotainment)



Fig. 180 Audi connect (Infotainment) home page

- ▶ Select: the **MENU** button > **Audi connect**.
- ▶ If necessary, confirm the note displayed with **Accept**.

A list of all of the available Audi connect Infotainment services is shown in the Infotainment system display ⇒ *fig. 180*.

You can also filter the Audi connect Infotainment services by category:

- ▶ Select: **MENU** button > **Audi connect** > left control button > for example, **Navigation** for the Audi connect Infotainment services in the navigation menu ⇒ *page 191*.

## Audi connect Infotainment services

### Basic functions

Applies to vehicles with Audi connect (Infotainment)

If available, functions specific to certain services are in the selection menu of that particular Audi

connect Infotainment service ⇒ *page 150*. The basic functions are in the corresponding options menu:

- ▶ Select: **MENU** button > **Audi connect** > *desired Audi connect Infotainment service* > right control button.

Depending on the Audi connect Infotainment service selected, the following basic functions are available:

### Save as preview\*

You can also see a preview of the selected Audi connect Infotainment services on the Audi connect Infotainment home page **1** ⇒ *page 188, fig. 180*.

### Show on map

You can show selected contents on the map and use them for route guidance.

### Log in

See ⇒ *page 187, Logging into myAudi in the vehicle*.

### Read out<sup>1)</sup>

You can allow the MMI to read out the selected contents.

### Call\*

If a phone number was assigned to an entry, you can call the number, for example to reserve tickets.

### Start route guidance

If a city was added to an entry, such as for **City Events**, you can use it as a navigation destination. Route guidance starts immediately.

### Change search area

The set search area can be changed at any time. Additional information on search areas can be found under ⇒ *page 206*. ▶

1) Not available in all languages.

## Closing Audi connect Infotainment services

Regardless of the function selected, you can close an Audi connect Infotainment service at any time and return to the home screen ⇒ *page 188, fig. 180.*

### Parking information

Applies to: vehicles with parking information

Information on parking locations and fees in the selected search area (for example **Nearby**).

- ▶ Select and confirm **Parking information**.

You can use the right control button to sort the parking locations **By distance** or **By availability**.

### Travel information

Applies to: vehicles with travel information

Information on attractions in the selected search area.

- ▶ Select and confirm **Travel information**.
- ▶ Select and confirm an attraction to display the details.

### Fuel prices

Applies to: vehicles with fuel prices

Information on gas stations with the lowest fuel prices for your vehicle in the selected search area.

- ▶ Select and confirm **Fuel prices**.

You can use the right control button to sort the fuel prices **By price** or **By distance**.

## Traffic light information

Applies to: vehicles with traffic light information



Fig. 181 Example: display of a speed recommendation

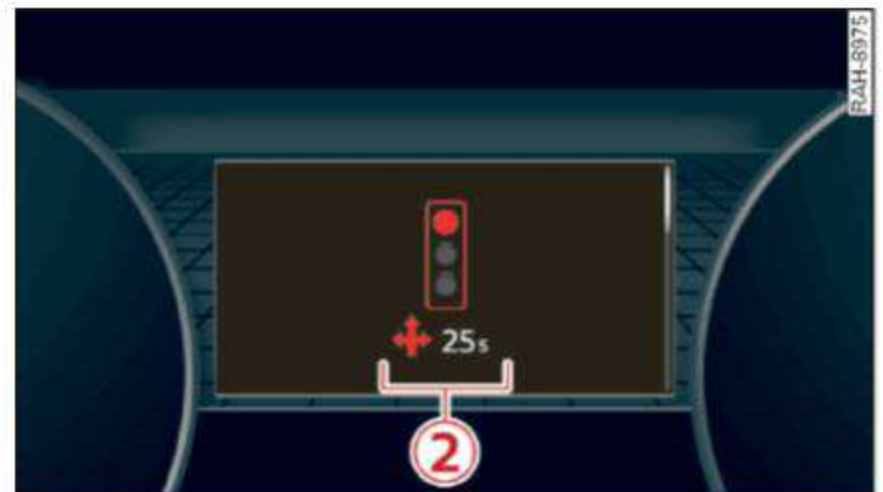

Fig. 182 Example: display of an estimated wait time

The traffic light information <sup>1)</sup> gives you a speed recommendation, at which to drive through the next green traffic light ① ⇒ *fig. 181* or informs you of the wait time at the next red light ②. The traffic light information can be displayed in the driver information system, in the status line of the Audi virtual cockpit\* or in the head-up display\*.

### General information

The traffic light information is subject to certain system limitations and may be unavailable or only partially available in the following situations:

- when the permitted speed limit is exceeded
- if the next traffic light is less than 100 ft (30 m) away
- if the estimated wait time at a red light is less than four seconds
- if there is no traffic light data available
- if the data connection was interrupted

<sup>1)</sup> Service in preparation at the time of printing. Can add later or is only available in certain regions.

## Audi connect (Infotainment)

- when the camera-based traffic sign recognition\* is malfunctioning ⇒ *page 97*
- when there are warnings from the camera-based traffic sign recognition\*

### Switching traffic light information on and off

- Select: **MENU** button > **Audi connect** > **Traffic light information** > *On* (☑) or *Off* (☐).

#### **WARNING**

- When traffic light information is shown, also always pay attention to the traffic situation, the distance to other vehicles and the area around the vehicle. The driver is always responsible for assessing the traffic situation.
- Always adapt your speed to the current weather, road and traffic conditions. The displayed information must never cause you to ignore legal traffic regulations and pose a safety risk.
- Regardless of the traffic light information, you should always monitor your speed using the speedometer and make sure you are adhering to the legal speed limit.
- The traffic light information does not adjust your vehicle's speed to the speed recommendation shown in the display.

#### **Tips**

- Traffic light information is not yet available in all cities and is not nationwide.
- Units of measurement and language settings are displayed based on how they were set in the MMI system settings ⇒ *page 245*.
- Always read the chapter ⇒ *page 194, Audi connect (Infotainment) general information*.

### Weather

Applies to: vehicles with weather information

Information on current weather conditions as well as weather forecasts for the selected search area.

- ▶ Select and confirm **Weather**.

You can also display the current weather conditions on the map, for example.

- ▶ Select: left control button > *an entry*.

### Flight information

Applies to: vehicles with flight information

Information on flights and current arrival/departure times in the selected search area.

- ▶ Select and confirm **Flight information**.

### City events

Applies to: vehicles with City events

Information on events in various categories in the desired search area.

- ▶ Select **City Events** > left control button > *category*.

### Online news

Applies to: vehicles with online news

You can check the current headlines of your favorite publications in the MMI.

Requirement: your myAudi account must be subscribed to newsfeeds and your vehicle must be connected to myAudi ⇒ *page 187*.

- ▶ Select: **Online news** > *desired newsfeed* > *a headline*. The entire news article will be displayed.

#### **Tips**

If you have not subscribed to any personal newsfeeds in your myAudi account, pre-configured newsfeeds will be displayed.

### Twitter

Applies to: vehicles with Twitter

*You can access the most important functions in your Twitter account through your MMI.*

Requirement:

You must have connected your myAudi account with Twitter. You can find additional information for this online at [www.audiusa.com/myaudi](http://www.audiusa.com/myaudi). ▶

You must have connected your vehicle with myAudi ⇒ *page 187*.

- ▶ Select **Twitter** > left control button > *desired function* (for example, **Trends**).

The following categories can be selected in the **Twitter** menu:

- **My tweets**: News Feed and the Tweets you have posted are listed.
- **Home**: the Tweets for everyone you follow are displayed.
- **Trends**: topics on Twitter that are currently popular within a country.

Different functions are available depending on the Twitter category you have selected:

- **New tweet**: you can post a new tweet using pre-made templates or using myAudi templates that you have created yourself.
- **Refresh**: the selected Twitter function is refreshed.
- **Favorite**: mark a Tweet as favorite to show you liked it.
- **Retweet**: you can quote a Tweet to share it with others.

### Tips

- Other settings such as account, language, Tweet security and location settings *cannot* be changed in the MMI. These changes must be made on the Twitter website.
- You can only connect *one* Twitter account with your myAudi account.
- Audi connect (Infotainment) makes it possible to access Twitter. Permanent availability cannot be guaranteed, because that depends on Twitter.

### Travel (travel guide)

Applies to: vehicles with Travel (travel guide)

*You can use the Audi MMI connect app to store points of interest on your mobile device (such as a smartphone) and then use them for route guidance in the MMI.*

Requirement:

The **Audi MMI connect** app must be installed and open on your mobile device.

You must be logged into your myAudi account in the **Audi MMI connect** app and you must have selected your vehicle.

The Wi-Fi function on your mobile device and on the MMI must be switched on.

The MMI must be connected to the network.

- ▶ Press: **MENU** button > **Audi connect** > left control button > **Information category** > **Travel**.

After opening the travel guide, travel tips in your area will be displayed including current ratings as well as the corresponding category.

- ▶ Press the left control button to change the category (such as bars nearby).

### WARNING

- It is only safe to use tablets, laptops, mobile devices and other similar devices when the vehicle is stationary because, like all loose objects, they could be thrown around the inside of the vehicle in a crash and cause serious injuries. Store these types of devices securely while driving.
- Do not use any wireless devices on the front seats within range of the airbags while driving. Also read the warnings in the chapter ⇒ *page 273, Front airbags*.

### Note

Always follow the information found in ⇒  *in Wi-Fi hotspot on page 194*.

### Tips

Units of measurement, language settings and time are shown in the Infotainment system display based on how they were set in the MMI system settings ⇒ *page 245*.

### Audi connect (Infotainment) in navigation

Applies to: vehicles with a navigation system and Audi connect (Infotainment)

- ▶ Select: **MENU** button > **Audi connect** > left control button > **Navigation**. ▶

## Audi connect (Infotainment)

The following Audi connect Infotainment services are currently available:

- Navigation with **satellite map**<sup>1)</sup> ⇒ *page 215*.
- **Point of Interest (POI) online search with voice recognition** (such as restaurants): plan route guidance using the MMI control panel ⇒ *page 207* and the voice recognition system ⇒ *page 167*.
- Set up destinations in your MMI using your **myAudi account** or the **satellite map view**<sup>1)</sup> ⇒ *page 215*.
- **Online traffic information**: receive up-to-the-minute traffic information about accidents, road construction and other incidents ⇒ *page 219*.
- **Map update**: import navigation map updates directly to your vehicle using an SD card or as an online update ⇒ *page 216*.

### Tips

- For the **map update** Audi connect Infotainment service via SD card, check the current software version in your vehicle and then check [www.audiusa.com/myaudi](http://www.audiusa.com/myaudi) to see if a newer version is available. You can also have the new navigation data installed by an Audi dealer, which can be done for an additional charge.
- You can find additional information about the **map update** online at [www.audiusa.com/myaudi](http://www.audiusa.com/myaudi).

## Audi connect (Infotainment) in Media menu

Applies to vehicles with Audi connect (Infotainment)

- ▶ Select: **MENU** button > **Audi connect** > right control button > **Entertainment**.
- **Online media and Internet radio**: offers access to different online media services as well as Internet radio and operation through the MMI using the **Audi MMI connect** app ⇒ *page 230*.

Applies to: vehicles with Wi-Fi audio player

- **Wi-Fi audio player**: you can access the media center through a Wi-Fi connected media player (such as a smartphone) ⇒ *page 229*.

### WARNING

It is only safe to use tablets, laptops, mobile devices and other similar devices when the vehicle is stationary because, like all loose objects, they could be thrown around the inside of the vehicle in a crash and cause serious injuries. Store these types of devices securely while driving.

### Note

Always follow the information found in  in *Wi-Fi hotspot on page 194*.

### Tips

- Also see the chapter ⇒ *page 194, Audi connect (Infotainment) general information*.
- For more information on the Wi-Fi audio player and supported devices, contact an authorized Audi dealer or authorized Audi Service Facility.

## Additional options

Applies to vehicles with Audi connect (Infotainment)

- ▶ Select: **MENU** button > **Audi connect** > right control button.

The following options are available in the Audi connect Infotainment services overview:

### About Audi connect

Here you will find legal information for Audi connect (Infotainment) usage.

### Log in\*

See ⇒ *page 187, Logging into myAudi in the vehicle*.

### Connection manager

See ⇒ *page 246*. ▶

<sup>1)</sup> AUDI AG provides access to services from third party providers. Permanent availability cannot be guaranteed, because that depends on the third party provider.

## License subscription

The validity and expiration date of your licenses are displayed. When the function is switched on , the message **Warning before subscription expires** will display to warn you that your license is about to expire.

## Refresh

The content of the selected Audi connect Infotainment service or the entire Audi connect (Infotainment) list is updated.

## Data privacy

Requirement: the ignition must be switched on.

Location and personal data are transmitted when using Audi connect services. If you do not want this information to be transmitted, activate data privacy.

- **Activate privacy:** the data connection is limited or deactivated. Some Audi connect services will not be available. In vehicles with Audi connect emergency call and service ⇒ *page 201*, location and vehicle data will be transmitted via the emergency call in cases of emergency. For online roadside assistance\*, only the voice call is made and no data is transmitted.
- **Deactivate data privacy:** if the data connection is limited or deactivated, you can switch on the data connection for the use of all Audi connect services. Select and confirm **Activate data connection**.

### Tips

Applies to: vehicles with emergency call function

In vehicles with Audi connect emergency call and service, a data connection is required. It cannot be deactivated. Location data is only transmitted together with vehicle data when emergency calls are made.

## Wi-Fi hotspot

Applies to: vehicles with Wi-Fi hotspot

*You can use the MMI as a Wi-Fi hotspot to connect up to eight Wi-Fi devices to the Internet. While driving, restricted use of unsecured, light, small wireless devices is only possible from the rear of the vehicle.*

Requirement: the ignition must be switched on.

- ▶ Select: **MENU** button > **Telephone** > right control button > **Wi-Fi settings**.

The following settings can be selected:

### Wi-Fi

The MMI Wi-Fi hotspot is deactivated at the factory. Switch the Wi-Fi hotspot to **Hotspot** before establishing a connection between your vehicle and your Wi-Fi device.

- **On:** the MMI Wi-Fi hotspot is active and visible to other devices. You can connect your Wi-Fi device to the MMI and use the Internet connection if necessary.
- **Off:** the MMI Wi-Fi hotspot is deactivated. An Internet connection for Wi-Fi devices is not possible.

### WARNING

- To reduce the risk of an accident, use the Audi connect Infotainment services with a Wi-Fi hotspot only in the rear seat when the vehicle is in motion, or only when the vehicle is stationary.
- It is only safe to use tablets, laptops, mobile devices and other similar devices when the vehicle is stationary because, like all loose objects, they could be thrown around the inside of the vehicle in a crash and cause serious injuries. Store these types of devices securely while driving.
- Do not use any wireless devices on the front seats within range of the airbags while driving. Also read the warnings in the chapter ⇒ *page 273, Front airbags*.
- As the driver, do not allow usage of the Wi-Fi hotspot to distract you from driving, as this could increase the risk of an accident.

### Note

- Under some conditions, certain mobile devices and operating systems may automatically switch from your vehicle's Wi-Fi hotspot to the device's mobile data connection. In that event, standard text and data usage rates would apply while the device's mobile data connection is in use. Please refer to documentation provided by your mobile device's manufacture and your data carrier for details, related terms and privacy statement.
- You are responsible for all precautions taken for data protection, anti-virus protection and protection against loss of data on mobile devices that are used to access the Internet through the Wi-Fi hotspot.

### Tips

- In vehicles without Audi connect (Infotainment)\*, the use of the Wi-Fi hotspot is only possible for the Wi-Fi audio player\*. A data connection to the Internet cannot be established.
- For additional information about the Audi connect Infotainment services, visit [www.audiusa.com/myaudi](http://www.audiusa.com/myaudi).

## Configuring the data connection

Applies to vehicles with Audi connect (Infotainment)

*The data connection for Audi connect Infotainment services is pre-configured at the factory. However, if a configuration should be necessary, you can adjust the following settings.*

- ▶ Select: **MENU** button > right control button > **Connection manager**.
- ▶ Select: right control button > **Online settings** > **Data connection settings**.

Using the **Data connection settings** menu, you can set when an Internet connection should be made. The Internet connection disconnects automatically once the requested Audi connect Infotainment service no longer requires any data.

The following settings can be selected:

## Audi connect (MMI)

With the **Audi connect (MMI)** function, you can **Allow** or **Deny** the use of Audi connect Infotainment services if the connection is set to **No request** or **With request**.

### Wi-Fi devices\*

Using the **Wi-Fi devices** function, you can **Allow** or **Deny** a connection to the Internet.

### WARNING

- As the driver, do not allow usage of the Wi-Fi hotspot to distract you from driving, as this could increase the risk of an accident.
- It is only safe to use tablets, laptops, mobile devices and other similar devices when the vehicle is stationary because, like all loose objects, they could be thrown around the inside of the vehicle in a crash and cause serious injuries. Store these types of devices securely while driving.
- Do not use any wireless devices on the front seats within range of the airbags while driving. Also read the warnings in the chapter ⇒ *page 273, Front airbags*.

### Note

Always follow the information found in ⇒  *in Wi-Fi hotspot on page 194*.

## Audi connect (Infotainment) general information

### Audi connect Infotainment services

Applies to vehicles with Audi connect (Infotainment)

### Tips

- You can only use services supported by Audi connect (Infotainment) if you have the optional MMI Navigation plus equipment with MMI touch\* and Audi connect (Infotainment).
- Use of the LTE\* mobile network standard is not available in every country. Contact an authorized Audi dealer or authorized Audi

- Service Facility or your cell phone service provider for additional information.
- Usage of Audi connect Infotainment services depends on the availability of services through third party providers.
- Audi connect Infotainment services are only available within the cell phone network coverage from your cell phone service provider.
- Audi connect Infotainment services are available in the USA. Audi connect Infotainment services are currently not available in Canada or in Mexico.
- Also read the information in the chapter ⇒ *page 174, Telephone.*
- Availability, scope, providers, screen display and costs of services may vary depending on the country, model, model year, end device and rates. For additional information, visit [www.audiusa.com](http://www.audiusa.com).
- An initial registration/activation on the myAudi platform at [www.audiusa.com/myaudi](http://www.audiusa.com/myaudi) is required to use individual services. You can contact an authorized Audi dealer or Audi connect (Infotainment) customer service at (877) 505-AUDI (2834) to receive information on options for expanding your usage and any costs that may result.
- The Audi connect Infotainment services are a Wi-Fi/Internet-based system. If the system does not function correctly even though all of the requirements are met, please try again later or contact Audi connect (Infotainment) customer service at (877) 505-AUDI (2834).
- For detailed information on Audi connect (Infotainment) and the Terms of Use, refer to [www.audiusa.com](http://www.audiusa.com).

### Data protection

Applies to vehicles with Audi connect (Infotainment)

#### Tips

- You can find additional information in your MMI in the options menu for the selected Audi connect Infotainment service and also online at [www.audiusa.com](http://www.audiusa.com).
- Your privacy is important to us.

- AUDI AG collects, processes, shares and transmits your personal information in accordance with legal regulations in order to ensure proper function and availability of the individual Audi connect Infotainment services. You can view the complete, current and valid Audi connect (Infotainment) data protection policy in your MMI. The myAudi platform is available for to you to activate additional Audi connect Infotainment services and to transfer data to your vehicle, among other services. A one-time registration is required to establish a connection to your vehicle. For this purpose, AUDI AG collects, processes, transmits and uses your required personal information as required for you to use the services provided by AUDI AG. Your information is not distributed to third parties. Using your cell phone with your myAudi platform allows you to transmit data for your Audi connect Infotainment services functions to your vehicle and you can allow specific vehicle data to be transmitted from your vehicle.
- By activating special information services that are part of your Audi connect (Infotainment) portfolio, you can use these functions directly in your vehicle by entering data to confirm your identity (to use social networks, for example). To do this, the identification information you provided is forwarded with the request to the respective service provider. Then you can access your personal content using a secure connection. This content is displayed in the vehicle for your use. Your personal content is not stored within Audi AG. The necessary connection information is processed and used for providing services and the proper function of the services in accordance with applicable legal guidelines.
- You can find additional information in your MMI in the options menu for the selected Audi connect Infotainment service and also online at [www.audiusa.com](http://www.audiusa.com).
- By providing Audi connect Infotainment services, Audi of America is authorized to collect, process, transmit and transfer

information about you and your vehicle. Additional information can also be found in your MMI in the options menu for the selected Audi connect Infotainment service.

- Information on our data protection measures in conjunction with the mobile Audi connect (Infotainment) application can be

found in the application's privacy policy. For additional information about the [www.audiusa.com/myaudi](http://www.audiusa.com/myaudi) website or other applications, websites or online services connected to Audi, visit [www.audiusa.com/privacy](http://www.audiusa.com/privacy).

## Troubleshooting

Applies to vehicles with Audi connect (Infotainment)

Problem	Solution
<b>Audi connect Infotainment services:</b> individual Audi connect Infotainment services are grayed out or not available.	Some Audi connect Infotainment services must be activated/configured through your personal myAudi account before using them for the first time. You can find detailed information online at <a href="http://www.audiusa.com/myaudi">www.audiusa.com/myaudi</a> .
<b>Wi-Fi hotspot:</b> it is not possible to connect through Wi-Fi.	Delete all existing Wi-Fi connections on your mobile device and restart it.

# Audi connect vehicle control

## Introduction

Applies to vehicles with Audi connect vehicle control

With the Audi connect vehicle control services <sup>1)</sup>, you can access various information or use individual functions in the **Audi MMI connect** app or in myAudi.

Audi connect vehicle control includes the following services:

- Remote locking and unlocking ⇒ *page 198*.
- Vehicle status report ⇒ *page 198*.
- Parking location ⇒ *page 198*.
- Geofencing Alert ⇒ *page 199*.
- Speed Alert ⇒ *page 199*.
- Valet Alert ⇒ *page 199*.
- Stolen Vehicle Locator ⇒ *page 199*.
- Online Audi service request ⇒ *page 199*.

### Tips

- Accessing specific data or controlling functions remotely depends on the charge level of the vehicle battery. Therefore, these functions only have limited availability after switching off the ignition.
- The services are provided through a SIM card installed in the vehicle. The cost of the call and data connections is included in the price for the services. Services are provided assuming that the cell phone network required for the installed SIM card is functioning and ready to operate. The available services set by Audi AG are only available within the cell phone network coverage area for the cell phone service provider selected by Audi AG.
- You can also find more information on Audi connect online at [www.audiusa.com](http://www.audiusa.com).

## Setup

Applies to vehicles with Audi connect vehicle control

To use Audi connect vehicle control services <sup>1)</sup>, please note the following:

### Creating and verifying a user account

- ▶ Create an account at [www.audiusa.com/myaudi](http://www.audiusa.com/myaudi) and verify it.

### Setting a key user in the vehicle

Requirements: the ignition must be switched on. Another key user must not be set in the vehicle. If necessary, reset the key user ⇒ *page 198*.

- ▶ Select in the Infotainment system: **MENU** button > **Audi connect** > if necessary, **Display available functions** > right control button > **Audi connect user management** > **Key user** > **Set key user**.
- ▶ Enter the user name for your verified account and enter the 10-digit vehicle code. You can rub the key tag for your remote control key to reveal the vehicle code ⇒ *page 31*.
- ▶ Select and confirm **Log in**.

You can now use the vehicle control services through the **Audi MMI connect** app or through [www.audiusa.com/myaudi](http://www.audiusa.com/myaudi).

### Using vehicle control services in the Audi MMI connect app

Requirement: your mobile devices must be compatible.

- ▶ Install and start the **Audi MMI connect** app on your mobile device.
- ▶ Log in to the **Audi MMI connect** app using your user name and password and select your vehicle.

### Tips

- Store the vehicle code in a secure place. It may be necessary to re-enter the vehicle code.

<sup>1)</sup> In preparation at the time of printing. The availability of the services offered depends on the country and may change over time.

- Pay attention to upper- and lower-case letters when entering the vehicle code.
- If you do not have the 10-digit vehicle code, contact an authorized Audi dealer or authorized Audi Service Facility.

### Additional options

Applies to vehicles with Audi connect vehicle control

#### License subscription

The validity and expiration date of your subscriptions are displayed. When **Warning before subscription expires** is activated, a message will be displayed warning you that your license is about to expire.

Select: **MENU** button > **Audi connect** > **Display available functions** > right control button > **License subscription**.

#### Resetting the primary user

For example, you can reset the key user when selling your vehicle in order to deactivate these services.

Requirement: the ignition must be switched on.

Select: **MENU** button > **Audi connect** > right control button > **Audi connect user management** > **Key user** > **Reset key user**.

#### Warning levels

Requirement: the primary user must have set one or more warning levels. Secondary users can only see if a warning level is active or not.

Select: **MENU** button > **Audi connect** > right control button > **Alerts**.

### Remote locking and unlocking

Applies to vehicles with Audi connect vehicle control

You can lock and unlock your vehicle using this service.

#### Requirement

- This requires the 4-digit PIN that you specified during the verification on [www.audiusa.com/myaudi](http://www.audiusa.com/myaudi).
- The vehicle must be stationary.

- The ignition must be switched off.

### Vehicle status report

Applies to vehicles with Audi connect vehicle control

The Driver Information System collects data under certain conditions and sends it to a server.

When data is stored, you can access values such as these using the service:

- Remaining range,
- Fuel tank level,
- Oil level,
- If the vehicle doors are open/closed or locked/unlocked,
- mileage,
- Next oil change
- Next service,
- Warning messages,
- If the parking lights are on/off.



#### WARNING

Do not ignore messages and warning or indicator lights that turn on in the vehicle because of the information in the status report. This could lead to break downs in on the road, accidents and serious injuries.

### Parking location

Applies to vehicles with Audi connect vehicle control

The vehicle collects data under certain conditions and sends it to a server.

When data is stored, you can access values such as these using the service:

- Vehicle location display
- Display of one's own location
- Route to your vehicle

If your mobile device also has a navigation function, you can navigate to your last known parking location.

#### Deactivating and activating parking position

- Select: **MENU** > **Audi connect** > **Car Finder parking position**.

If you do not set ✓, no location information will be sent to the server. ►

**i Tips**

- The new parking location cannot be determined with this service if the vehicle is moved after shutting the vehicle off and without switching the ignition on and off again, for example when being towed or if the vehicle is stolen.
- If the vehicle is moved and shut off again using the second key, for example, the new parking location is transmitted to the server after switching the ignition off.

## Geofencing Alert

Applies to vehicles with Audi connect vehicle control

You can set approved and forbidden zones for your vehicle using this service. If your vehicle leaves an approved zone or enters a forbidden zone, you will be notified by a push notification and/or an e-mail. You can set up to five zones and also assign time limits.

**Requirement**

- You must be verified as the primary user of your vehicle on myAudi.

**i Tips**

You can set on myAudi if you would like to be notified via push notifications and/or e-mail.

## Speed Alert

Applies to vehicles with Audi connect vehicle control

You can set up to two speed limits for your vehicle using this service. If your vehicle exceeds a set speed limit, you will be notified by a push notification and/or e-mail.

**Requirement**

- You must be verified as the primary user of your vehicle on myAudi.

**i Tips**

You can set on myAudi if you would like to be notified via push notifications and/or e-mail.

## Valet Alert

Applies to vehicles with Audi connect vehicle control

If you give your vehicle over to a parking service, you can set a zone and a speed limit using the **Audi MMI connect** app. If the vehicle leaves the zone or exceeds the speed limit, you will be notified by a push notification and/or e-mail.

**Requirement**

- You must be verified as the primary user of your vehicle on myAudi.

**i Tips**

You can set on myAudi if you would like to be notified via push notifications and/or e-mail.

## Stolen Vehicle Locator

Applies to vehicles with Audi connect vehicle control

This service helps you to track your vehicle if it is stolen.

Proceed as follows if there is a theft:

- ▶ Contact the police. You receive a Case ID.
- ▶ Call the service hotline and give your Case ID.

The service hotline will forward the established data to the police.

**i Tips**

You receive the Audi Service hotline number when you purchase your vehicle.

## Online Audi service request

Applies to vehicles with Audi connect vehicle control

Requirement: to be able to use online Audi service request, you must activate the service at [www.audiusa.com/myaudi](http://www.audiusa.com/myaudi) and select an authorized Audi dealer or authorized Audi service facility.

Online Audi service request transmits service-relevant data to your selected authorized Audi dealer or authorized Audi service facility. They will contact you before your next service appointment. ▶

### Tips

You can deactivate the online Audi service request at [www.audiusa.com/myaudi](http://www.audiusa.com/myaudi).

## Emergency call

### Introduction

Applies to: vehicles with emergency call function

Depending on the country and the vehicle equipment, the following functions may be available.

With the **emergency call**, you can call for help in dangerous situations as quickly as possible. Use this function when emergency help is needed ⇒ *page 201*.

With **online roadside assistance**, you can request assistance if there is a breakdown or a minor accident ⇒ *page 202*.

#### Tips

- The services are provided through a SIM card installed in the vehicle. The cost of the call and data connections is included in the price for the services. Services are provided assuming that the cell phone network required for the installed SIM card is functioning and ready to operate. The available services set by Audi AG are only available within the cell phone network coverage area for the cell phone service provider selected by Audi AG.
- You can find what data will be transferred at [www.audiusa.com](http://www.audiusa.com).
- These services cannot be deactivated using the settings in the Infotainment system.

## Emergency call

### Description

Applies to: vehicles with emergency call function

An emergency call is a combination of data transmission and a phone call. The data transmission from your vehicle forwards important information, such as the vehicle and position data, to the emergency call center.

### Making an emergency call

Applies to: vehicles with emergency call function

The emergency call can be made two different ways.

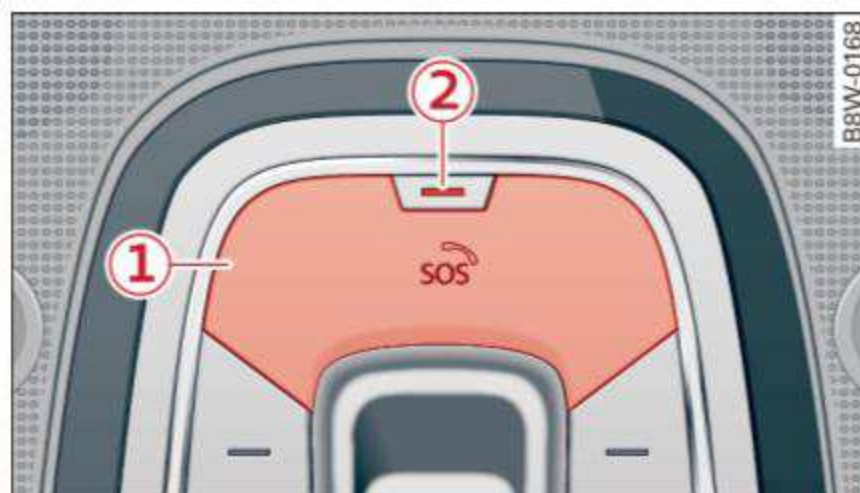

**Fig. 183** Front headliner: cover for the emergency call button

Requirement: the LED ② must be green.

### Manual emergency call

Requirement: the ignition must be switched on.

- ▶ Tap the cover ① to open it.
- ▶ Press and hold the emergency call button until the LED ② blinks green. The emergency call is made.
- ▶ If the emergency call button is pressed by mistake, then press it again immediately until the LED stays green. The emergency call is canceled.

### Automatic emergency call

The vehicle electrical system initiates an automatic emergency call under certain circumstances, for example if an airbag deploys. The LED in the emergency call button ② blinks green. The emergency call is made. This cannot be canceled.

Note the following LED conditions:

- **Green** – the emergency call function is available.
- **Red** – there is an error in the emergency call function. Contact an authorized Audi dealer or authorized Audi Service Facility. No emergency call can be made.
- **Off** – the emergency call function is not available, perhaps because no network is available. ▶

### Tips

If the emergency call is canceled due to a poor connection, then the system automatically tries to connect again.

### Messages

Applies to: vehicles with emergency call function

#### **Emergency call function: malfunction! Restricted functionality. Please contact Service**

If the indicator light turns on and the message appears, you can only make an emergency call with restricted function. For example, you cannot call the emergency call center, but data may still be transmitted under certain circumstances/ Drive to an authorized Audi dealer or authorized Audi Service Facility immediately to have the malfunction corrected.

#### **Emergency call function: malfunction! Function unavailable. Please contact Service**

If the indicator light turns on and the message appears, you cannot make an emergency call. Drive to an authorized Audi dealer or authorized Audi Service Facility immediately to have the malfunction corrected.

## Online roadside assistance

### Description

Applies to: vehicles with online roadside assistance

An online roadside assistance call <sup>1)</sup> is a combination of data transmission and a phone call. The data transmission from your vehicle forwards important information to the Audi service center, such as the vehicle and position data.

### Calling online roadside assistance

Applies to: vehicles with online roadside assistance

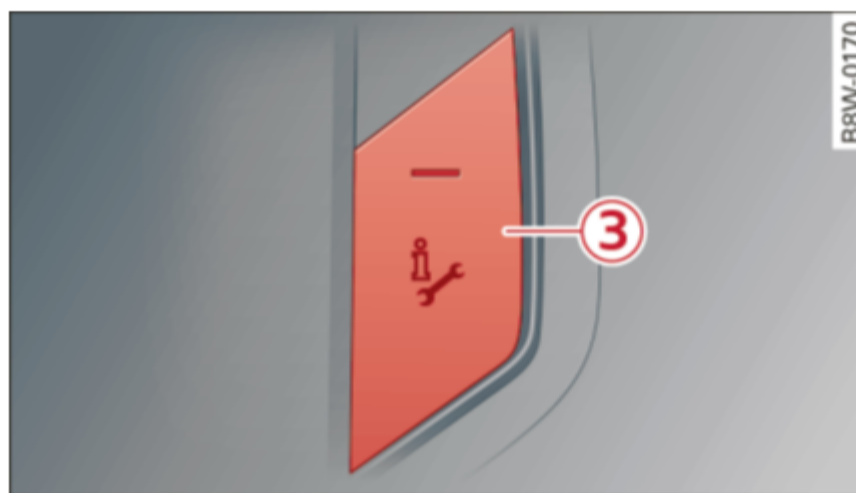



Fig. 184 Front headliner: online roadside assistance button

### Calling online roadside assistance

- ▶ Press the button . The LED in the button turns red. The online roadside assistance call is placed.
- ▶ If you press the button  by mistake, then press it again. Or
- ▶ Select and confirm **Cancel** or **End call** in the Infotainment system.

### Audi incident assistance

A minor accident is detected by the vehicle electrical system. You have the option of selecting between **Call online roadside assistance** or **Make emergency call**.

- ▶ Select one of the options and confirm it by pressing the control knob.

### Tips

If the roadside assistance call is canceled due to a poor connection, then the call must be made again.

<sup>1)</sup> The availability of the services offered depends on the country and may change over time.

# Navigation

## Opening navigation

Applies to: vehicles with navigation system

The navigation system directs you to your destination, around traffic incidents and on alternative routes, if desired.



Fig. 185 Diagram: Enter destination menu

► Press the **NAV/MAP** button.

The **Enter destination** menu is displayed after opening navigation. The following information can be displayed in the Infotainment system display:

①	Input field for free text search . . .	204
②	Home address . . . . .	205
③	Last destinations . . . . .	204
④	Stored favorites . . . . .	205

As soon as you select an entry from the list (depending on the vehicle equipment), the corresponding destination displays as a map preview\* ⑤ ⇒ fig. 185.

If you have connected a cell phone to the MMI, your directory contacts will also be listed if they have navigation data assigned to them.

The **Favorites** ④ ⇒ fig. 185 menu item as well as the directory/contacts are only shown in the **Enter destination** menu if you have entered one or more characters using the input field.

### Switching between destination entry and the map:

- Press the **NAV/MAP** button repeatedly until the map is displayed. **Or:** select the left control button > **Switch to map**.

### ⚠ WARNING

- The demands of traffic require your full attention. Always read the chapter ⇒ page 147, *Traffic safety information*.
- Obey all traffic laws when driving.
- The route calculated by the navigation system is a recommendation for reaching your destination. Obey traffic lights, stopping restrictions, one-way streets, lane change restrictions, etc.

### ! Note

- If the driving directions conflict with traffic laws, obey the traffic laws.
- To reduce the risk of an accident, adjust the volume of the navigation system so that signals from outside the vehicle, such as police and fire sirens, can be heard easily at all times.

### i Tips

- Snow and obstructions on the GPS antenna or interference caused by trees and large buildings can impair satellite reception and affect the system's ability to determine the vehicle position. Several deactivated or malfunctioning satellites can also interrupt GPS reception and affect the system's ability to determine the vehicle position.
- Because street names sometimes change, the names stored in the MMI may in rare cases differ from the actual street name.

## Entering a destination

### Free text search for destinations

Applies to: vehicles with navigation system

With the free text search, you can enter the navigation destination data all at once in any order using the MMI touch control pad\* or the letter/number speller (for example, 20 Main St., Los Angeles). Likewise, you can search for points of interest, contacts, previous destinations or favorites to navigate to the desired address.

Press the **NAV/MAP** button repeatedly until the **Enter destination** menu is displayed ⇒ page 203, fig. 185.

- ▶ Push the control knob up. The input field is displayed ① ⇒ page 203, fig. 185.
- Enter one or more search terms into the input field.
- If available, confirm the input suggestion\* to complete the entry or a word suggestion\*. See ⇒ page 155, Letter/number speller.
- Turn the control knob to the right to change the results list.
- Select and confirm a destination from the results list.
- Select and confirm **Start route guidance**.

The route displays as an overview in the map. Route guidance is already active.

### Narrowing the search area

All countries/states are selected at the factory for the free text search.

- Select: the right control button > -Country/state selection- in the input field 1 ⇒ page 203, fig. 185.
- Select the country or state (●) that should be searched for in the free text search in order to narrow the number of results and increase the search speed. The selected entry in the country/state selection is stored. **Or:** select **All countries/states**.

#### Tips

- The MMI input suggestions depend on the last navigated destinations.

- Up to 50 entries can be stored in the last destinations list.
- Additional information on free text searches can be found under ⇒ page 157.

### Loading previous destinations

Applies to: vehicles with navigation system

Your last destinations are automatically stored and can be loaded directly as a destination.

Requirement: a destination was already navigated to.

- ▶ Press the **NAV/MAP** button repeatedly until the **Enter destination** menu is displayed ⇒ page 203, fig. 185.

Your last destination is listed directly in the **Enter destination** menu under the home address and identified with the symbol ③ ⇒ page 203, fig. 185.

- Select and confirm one of the last destinations from the list.
- Select and confirm **Start route guidance**.

### Deleting previous destinations

- Select one of the last destinations from the list.
- Select: right control button > **Delete destination** > **Delete this last destination** or **Delete all last destinations**.

The selected destination or all last destinations is/are deleted and no longer displayed in the **Enter destination** menu.

### Entering an address

Applies to: vehicles with navigation system

As an alternative to free text search, you can also enter an address in stages.

- ▶ Press the **NAV/MAP** button repeatedly until the **Enter destination** menu is displayed ⇒ page 203, fig. 185.
- ▶ Select: left control button > **Enter address**.

- **Entering a destination using a country/state:** select and confirm **Country/state**. Select and confirm a country/state directly from the list. ▶

**Or:** search for a country/state using the input field.

- **Entering a destination using the City/ZIP code:** select and confirm **City/ZIP code**. Enter a city or a ZIP code. **Or:** select and confirm a city from the list.
- Select and confirm additional details about the destination such as **Street, House number** or **Downtown**.
- **Destination entry using a street intersection\*:** Requirement: you must enter a street. Select and confirm **Intersection**. Select and confirm a street directly from the list. **Or:** search for a street using the input field.
- Select and confirm **Start route guidance**.

### Selecting a destination on the map

Applies to: vehicles with navigation system and MMI touch

*A point on the map can be used as the destination.*

- **Adjusting the scale:** turn the control knob to the left or right.
- **Activating crosshairs:** press the control knob. The crosshairs are shown on the map.
- **Moving the crosshairs:** move the crosshairs to the destination using the MMI touch control pad\* ⇒ *page 152*.
- **Setting as destination:** press the control knob when the crosshairs are shown. If necessary, select and confirm **Add as stopover** and then **Start route guidance**.
- **Hiding the crosshairs:** press the **BACK** button.

**Additional information about the location of the crosshairs:** when you select map content using the crosshairs, a display of available information appears (such as street name, address or points of interest) ⑫ ⇒ *page 213, fig. 193*.

### Setting a home address/favorite as the destination

Applies to: vehicles with navigation system

*You can quickly and easily start route guidance to your home address using the home address function. Favorites allow easier access to frequently used destinations.*

- ▶ Press the **NAV/MAP** button repeatedly until the **Enter destination** menu is displayed ⇒ *page 203, fig. 185*.

#### Setting a home address as the destination

Requirement: a home address must be stored ⇒ *page 210*.

Your **Home address** is shown directly in the **Enter destination** menu ② ⇒ *page 203, fig. 185*.

- Select: *Home address* > **Start route guidance**.

#### Setting a favorite as the destination

Requirement: a favorite must be stored as a destination ⇒ *page 211*.

- Enter at least the first three letters of the desired favorite in the free text search input field. The favorites found are shown in the Infotainment system display ④ ⇒ *page 203, fig. 185*.
- Select and confirm the desired entry.
- Select and confirm **Start route guidance**.

#### Tips

- Additional settings for the home address can be found under ⇒ *page 210*.
- Additional settings for the favorites can be found under ⇒ *page 211*.

### Transferring a destination from the directory

Applies to: vehicles with navigation system

You can navigate directly to destinations in the directory.



Fig. 186 Possible directory/contacts

Requirement: an address with navigation data or a navigation destination must already be assigned to a contact ⇒ *page 211*.

- ▶ Press the **NAV/MAP** button repeatedly until the **Enter destination** menu is displayed ⇒ *page 203, fig. 185*.
- ▶ Select: left control button > **Directory** > a contact.

The directory/contacts are shown in alphabetical order and are marked with symbols to indicate the storage location:

- ① Business address
- ② Private address
- ③ Business destination
- ④ Private destination

- Select and confirm an address or a destination. When you have selected a destination, the route guidance can be started directly.
- Check the address input again when selecting an address.
- Then select and confirm **Start route guidance**.

Additional directory functions in the navigation system can be found under ⇒ *page 211*.

#### **i** Tips

- Addresses that have been imported from your cell phone into the MMI can also be used as a destination.

- If a contact is grayed out in the directory, this contact has neither a destination nor an address assigned to them.

### Point of interest search

Applies to: vehicles with navigation system

- ▶ Press the **NAV/MAP** button repeatedly until the **Enter destination** menu is displayed ⇒ *page 203, fig. 185*.
- ▶ Select: left control button > **Points of interest**.
- **Changing the search area:** select and confirm **Search area** > a search area from the list.

The following search categories are available:

**Nearby:** points of interest can be selected from different categories. The points of interest are listed starting from the immediate vicinity of the vehicle up to a radius of approximately 124 miles (200 km).

**Along the route:** points of interest along the route can only be selected during active route guidance. The points of interest are located directly along or in the immediate vicinity of the calculated route. The points of interest can likewise be selected from various categories. For example, you can search for a hotel or parking lot at the destination.

**Near destination/Near stopover:** points of interest near a destination or a stopover can only be selected during active route guidance. The points of interest can likewise be selected from various categories. For example, you can search for a hotel or parking lot at the destination.

**In a new city:** select a country/state or search in a new city. Enter the name of the desired city. Points of interest can be selected from various categories. This function allows you to search for points of interest in any city regardless of the active route guidance or the vehicle position.

- **Search for a point of interest name in the selected search area:** enter the name of the point of interest.
- **Searching for a point of interest in a specific category:** select **Select category**. Select and confirm a category such as **Restaurants**.

**i Tips**

- Distances to points of interest are displayed as a straight-line distance from your current location. The actual distance from your current location to the point of interest is updated automatically. The list of found points of interest is not resorted when this happens.
- There may be entries in the list that cannot be displayed completely due to their length. Select the corresponding entry from the list. Select: right control button > Show destination details. Detailed information for the selected entry in the list is then displayed.

**Online point of interest search (online search)**

Applies to: vehicles with a navigation system and Audi connect (Infotainment)

*You can search for points of interest on the Internet.*

Requirement: the requirements for Audi connect (Infotainment) must be met ⇒ *page 187*.

- ▶ Press the **NAV/MAP** button repeatedly until the **Enter destination** menu is displayed ⇒ *page 203, fig. 185*.
- ▶ Select: left control button > **Online search**. The search area last set is displayed in the input field.
- **Changing the search area:** select: right control button > **Select search area**.
- **Searching for online destinations in the selected search area:** enter a new city/state if necessary. Enter the search term, such as hotel. Press the control knob. Select and confirm an online destination from the list.
- **Searching for online destinations in a specific category:** select and confirm **Select category**. Select and confirm a category such as **Restaurants**.

Find which search areas are available under ⇒ *page 206, Point of interest search*.

You can search for online destinations using the voice recognition system ⇒ *table on page 170*.

**i Tips**

Always read the chapter ⇒ *page 194, Audi connect (Infotainment) general information*.

**Accessing destinations from myAudi account**

Applies to: vehicles with a navigation system and Audi connect (Infotainment)

*Import individual destinations from your myAudi account into the MMI.*

Requirement:

The requirements for Audi connect (Infotainment) must be met ⇒ *page 187*.

You must have a registered myAudi account at [www.audiusa.com/myaudi](http://www.audiusa.com/myaudi). You must have a vehicle assigned to your myAudi account and you must have stored one or more destinations.

- ▶ Press the **NAV/MAP** button repeatedly until the **Enter destination** menu is displayed ⇒ *page 203, fig. 185*.
- ▶ Select: left control button > **myAudi contacts**.
- ▶ If necessary, enter your myAudi user data or your myAudi PIN ⇒ *page 187*. The contacts stored in myAudi are displayed.
- Select and confirm a contact.
- Select and confirm a private or business destination.
- Select and confirm **Start route guidance**.

**i Tips**

- You only need to enter the myAudi user data one time.
- You can receive your myAudi PIN if you have set up a myAudi account.
- For additional information, visit [www.audiusa.com](http://www.audiusa.com).

**Entering a destination using geo coordinates**

Applies to: vehicles with navigation system

- ▶ Press the **NAV/MAP** button repeatedly until the **Enter destination** menu is displayed ⇒ *page 203, fig. 185*.

- ▶ Select: left control button > **Geographical coordinates**.
- Select **Latitude/Longitude**.
- Press the control knob to set the individual values.
- Turn the control knob to the left/right to change the selected value.
- Select and confirm **Start route guidance**.

### Adding a stopover

Applies to: vehicles with navigation system

You can enter an additional destination when route guidance is active.



Fig. 187 Example: active route guidance with stopover

Requirement: route guidance must already be active.

- ▶ Press the **NAV/MAP** button repeatedly until the **Enter destination** menu is displayed ⇒ page 203, fig. 185.

### Entering a destination as a stopover

- Enter a destination in the input line ⇒ page 204.
- Select and confirm a destination from the results list.
- Select and confirm **Add as stopover**.

### Deleting a stopover

- Push the control knob up. Free text search and active route guidance are displayed. **Or:** turn the control knob to the left until the active route guidance is shown.
- Select and confirm **Delete stopover** ② ⇒ fig. 187.
- The stopover is deleted.

### Cancel route guidance

Applies to: vehicles with navigation system

Requirement: route guidance must be active.

- ▶ Press the **NAV/MAP** button repeatedly until the **Enter destination** menu is displayed ⇒ page 203, fig. 185.
- ▶ Turn the control knob to the left until the active route guidance is shown ⇒ page 208, fig. 187.
- ▶ Select and confirm **Cancel route guidance** ① ⇒ page 208, fig. 187. The destination is deleted. **Or:** select the right control button > **Cancel route guidance**.

### Additional options when entering a destination

Applies to: vehicles with navigation system

- ▶ Press the right control button.

Depending on the selected function, the following options may be available when entering a destination:

**Cancel route guidance:** Requirement: route guidance must be active. Route guidance is canceled. For additional information, see ⇒ page 208.

**Country information:** you can display the applicable urban and rural speed limits for any country/state. If this function is activated, the information will be automatically shown to you in the route information ⑦ ⇒ page 213, fig. 192 when the speed limit is exceeded ⇒ page 215.

**Country/state selection:** see ⇒ page 204, *Narrowing the search area*.

**Route criteria:** see ⇒ page 212, *Route criteria*.

**Show location on map:** Requirement: you must have selected a destination from the results list. The destination entered is displayed on the map.

**Parking at this location\*:** Requirement: you must have selected a destination from the results list. All parking options near the selected location are displayed in the Infotainment system.

**Delete:** the selected entry is deleted. You can delete individual entries or all entries (for example, favorites or last destinations).

**Audi connect at this location\***: Requirement: you must have selected a destination from the results list. Allows you to search for items in the vicinity of the selected location, such as **Travel information**.

**Online traffic data\***: the online traffic information ⇒ *page 219* can be switched on or off.

**Add destination to contact**: see ⇒ *page 211*.

**Store as favorite**: see ⇒ *page 211*.

**Voice guidance**: see ⇒ *page 212*.

**Navigation settings**: see ⇒ *page 211*.

### Tips

Information on online traffic data\* can also be found online at [www.audiusa.com](http://www.audiusa.com).

## Personal route assistance

Applies to: vehicles with navigation system and personal route assistance

*Your MMI can learn the routes that you drive frequently and, depending on the current vehicle position, suggest route guidance (for example, your daily commute to work and back).*



**Fig. 188** Example: display of personal routes in the "Enter destination" menu

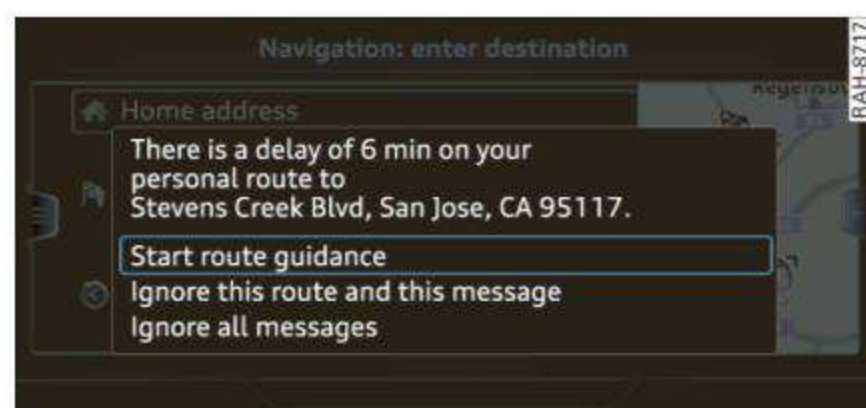

**Fig. 189** Information on personal route

- ▶ Press the **NAV/MAP** button repeatedly until the **Enter destination** menu is displayed ⇒ *page 203, fig. 185*.
- ▶ Select: right control button > **Navigation settings** > **Personal route assistance**.

When the function is switched on , the MMI records the frequently-driven routes regardless of whether a destination was entered and reached or not.

As long as route guidance is not active, your personal routes are listed in the **Enter destination** menu under the home address and indicated with the symbol ① ⇒ *fig. 188*. When personal route assistance is switched on, this symbol is displayed in the Navigation menu and in the Infotainment system display status line at the same time.

The distance to the destination and the calculated arrival time are also displayed for your personal routes. Without starting route guidance, your MMI monitors the traffic conditions for your personal routes and shows possible traffic incidents for the possible routes to be driven in the Infotainment system display ② ⇒ *fig. 188*.

A message will be displayed if there is a large traffic incident (more than 12 minute delay) regardless of which menu is selected ⇒ *fig. 189*. Select and confirm one of the following options:

- **Start route guidance**: the MMI starts the route guidance for the personal route displayed and searches for a faster route if available.
- **Ignore this route and this message**: the displayed destination with all applicable personal routes is no longer factored into the current trip. No more messages are shown for the displayed destination. The displayed destination with all applicable personal routes will be factored into the trip again only after stopping the vehicle and switching the ignition on again.
- **Ignore all messages**: all personal routes are no longer factored into the current trip. No more messages are displayed. Messages for personal routes when there is increased traffic will appear again after the vehicle is stopped and the ignition is switched on again.

As soon as you switch off personal route assistance, the symbol in the status line turns off and your trips are no longer recorded. Trips that were already stored remain stored.

### Deleting personal routes:

- Select the desired personal route in the **Enter destination** menu ⇒ *fig. 188*.
- Select: right control button > **Delete destination**.

### Deleting all personal routes:

- Select: **MENU** button > **Settings** > left control button > **MMI settings** > **Factory settings**.
- Select: **Navigation and online memory** > **Restore factory settings** ⇒ *page 246*.

### **i** Tips

- Personal routes are learned based on the vehicle position. The route is prioritized according to how frequently you drive to a destination.
- A maximum of three personal routes are displayed in the **Enter destination** menu. Based on the current vehicle position, the traffic situation for the route that is most likely to be driven out of the three routes will always be monitored.
- Please note that personal routes that have already been stored will remain stored after the ignition is switched off and they must be deleted manually.

## Alternative routes

Applies to: vehicles with navigation system



**Fig. 190** Diagram: display of alternative routes in the overview map

Requirement: a destination must be entered and the route guidance must be started.

- ▶ Press the **NAV/MAP** button repeatedly until the **Enter destination** menu is displayed ⇒ *page 203, fig. 185*.
- ▶ Select: right control button > **Navigation settings** > **Show alternative routes**.

Three routes are displayed in the overview map after you enter a destination.

Up to three route suggestions and their properties are displayed on the overview map when the function is switched on  ⇒ *fig. 190*.

If available, the following information will appear on the route suggestions:

- Route type (fast ①, fast alternative ②, economic route ③)
- Distance to the destination and the calculated arrival time
- Traffic congestion along the route including time delays

The route that was calculated according to the route criteria you selected is shown on the overview map. The special properties of the route are also displayed ④ ⇒ *fig. 190* and given as a spoken message.

Using the control knob, you can select the possible routing for the alternative routes and show them on map. Select and confirm the desired route that you would like to use for route guidance.

## Additional settings

### Home address

Applies to: vehicles with navigation system

- ▶ Press the **NAV/MAP** button repeatedly until the **Enter destination** menu is displayed ⇒ *page 203, fig. 185*.

### Storing a home address

- Select and confirm **Home address** ② ⇒ *page 203, fig. 185*. After opening the home address for the first time, you will be asked to create a home address.
- Select and confirm **Create now**.
- Enter a destination or select a destination from the list. **Or:**

- Select and confirm a destination > right control button > **Store as home address.**

### Editing the home address

- Select the **Home address** ② ⇒ *page 203, fig. 185.*
- Select: right control button > **Edit home address.**
- Select and confirm a new destination as the home address.

The selected destination is stored as the new home address.

### Favorites

Applies to: vehicles with navigation system

- ▶ Press the **NAV/MAP** button repeatedly until the **Enter destination** menu is displayed ⇒ *page 203, fig. 185.*
- **Storing a destination as a favorite:** search for the desired destination using the input field. **Or:** select a destination from the list. Select: right control button > **Store as favorite.**
- **Renaming a favorite:** select the left control button > **Favorites** > *a favorite from the list* > right control button > **Rename favorite.**
- **Move favorite:** select *a favorite from the list* > right control button > **Move favorite.** Select and confirm the location of the selected favorite.
- **Deleting a favorite:** select *a favorite from the list* > right control button > **Delete favorite** > **Delete this favorite** or **Delete all favorites.**

### Directory contacts

Applies to: vehicles with navigation system

*Two addresses (private/business) can be assigned as destinations for each contact in the directory.*

- ▶ Press the **NAV/MAP** button repeatedly until the **Enter destination** menu is displayed ⇒ *page 203, fig. 185.*

### Storing a destination as a contact in the directory

Requirement: a cell phone must be connected to the MMI ⇒ *page 174.*

- Select: *a destination* > right control button > **Add destination to contact.**
- Enter the first letters of the desired contact in the free text search input field ⇒ *page 203, fig. 185* and then select a contact from the list.
- Select and confirm **Add business destination** or **Add private destination.**

### Navigation settings

Applies to: vehicles with navigation system

- ▶ Press the **NAV/MAP** button repeatedly until the **Enter destination** menu is displayed ⇒ *page 203, fig. 185.*
- ▶ Select: right control button > **Navigation settings.**

Depending on the selected function, the following settings can be selected:

#### Show alternative routes

Up to three suggested routes are shown on the map when this function is switched on  ⇒ *page 210.*

#### Low fuel warning

A message is displayed if the fuel gauge goes below the reserve marking when this function is switched on . Confirming this message displays a list of gas stations in the area. When a gas station is selected, route guidance from the current vehicle position is calculated.

#### Trailer mode\*

Trailer mode is switched off at the factory.

When the function is switched on , the maximum permitted speed for vehicles with trailers is incorporated into the route guidance and the calculated arrival time is adjusted accordingly. Trailer mode is displayed using symbols  in the side menu on the map. ▶

### Personal route assistance\*

Personal route assistance is switched off at the factory.

Your trips are recorded and destinations are suggested by the MMI when this function is switched on  ⇒ *page 209*.

The personal route assistance is indicated by the  symbol in the status line of the Infotainment system display.

### Notification when nearby\*

The notification when nearby is switched off at the factory.

The MMI notifies you when you are approaching selected points of interest when this function is switched on . You can also have a **Notification tone**.

### Presentation mode

The **Presentation mode** helps you to effectively plan a trip and follow the planned route without moving the vehicle. You can use **Select starting point** when you would like to calculate a route starting from a location other than the vehicle position, for example. Start **Presentation mode** to simulate route guidance.

### Route criteria

Applies to: vehicles with navigation system



Fig. 191 Possible route criteria

► Press the  button repeatedly until the **Enter destination** menu is displayed  
⇒ *page 203, fig. 185*.

► Select: right control button > **Route criteria**.

① **HOV/carpool lanes**<sup>1)</sup>: with the **Avoid** function, HOV lanes are excluded when calculating routes. With **Allow**, the MMI will route you through HOV lanes and show them.

② **Highways** / ③ **Toll roads** / ④ **Ferries**: if the navigation system should not include highways, toll roads or ferries - if possible - when calculating routes, you can select the **Avoid** function.

### Voice guidance

Applies to: vehicles with navigation system

► Press the  button repeatedly until the **Enter destination** menu is displayed  
⇒ *page 203, fig. 185*.

► Select: right control button > **Voice guidance**.

**Voice guidance**: voice guidance can be **Complete** or **Shortened**. With the **Traffic** function, voice guidance prompts are only given when there are traffic incidents on your route. When **Off** is selected, no voice guidance is given.

**Voice guidance during phone call**: voice guidance during a phone call can be switched on or off.

**Entertainment fader**: see ⇒ *page 250*.

**Voice guidance volume**: you can adjust the volume during voice guidance using the On/Off knob  
⇒ *page 148* You can also find additional information under ⇒ *page 250*.

1) High occupancy vehicle

## Map

### Map operation

Applies to: vehicles with navigation system



Fig. 192 Example: 3D map with the crosshairs switched off



Fig. 193 Example: standard map with the crosshairs switched on

- ▶ Press the **NAV/MAP** button repeatedly until the map is displayed ⇒ *fig. 192*.

### Zooming in/out on the map

- Turn the control knob to the left or to the right. Alternatively, you can also zoom in/out on the map using the MMI touch control pad\* ⇒ *page 153*, if the crosshairs are switched on.  
**Or:** turn the left thumbwheel on the multifunction steering wheel\* ⇒ *page 13*.

### Turning the crosshairs on/off

- **Switching the crosshairs on:** press the control knob in the map view ⇒ *fig. 192*.
- **Switching the crosshairs off:** press the **BACK** button.

### When the crosshairs are switched off ⇒ *fig. 192*:

- ① Direction. For additional information, see ⇒ *page 215*.
- ② The distance to the destination includes the calculated arrival time.

- ③ When the **trailer mode** function is switched on , the corresponding symbol is displayed next to the arrival time.
- ④ Scale: turn the control knob to the left or right to decrease or increase the scale. When the **Automatic zoom** function is switched on , an "A" for "Automatic" is displayed in the magnifying glass.
- ⑤ Altitude
- ⑥ Vehicle position
- ⑦ Route information: various information will be displayed during active route guidance (for example, the upcoming maneuver including calculated distance and street names). The display also provides traffic information or points of interest on the current route.
- ⑧ Road currently being driven on

### When the crosshairs are switched on ⇒ *fig. 193*:

- ⑨ The crosshairs: move the crosshairs in the desired direction and set a point on the map using the MMI touch control pad\* or the control knob. When the crosshairs are turned off, the road being currently driven on is shown.
- ⑩ Speed limit display<sup>1)</sup>: display of the maximum permitted speed on the expressways and highways.
- ⑪ Entertainment sliding menu\*: see ⇒ *page 153*.
- ⑫ Additional information on the crosshairs position: if you move the crosshairs to a location on the map, available information for the current position is displayed. Tap briefly on the MMI touch control pad. **Or:** press the control knob. In the destination details, you can start route guidance to the displayed location. Select and confirm **Start route guidance**.
- ⑬ Map contents (points of interest, favorites). When there are multiple points of interest in the immediate vicinity, the symbols are shown stacked on the map.

<sup>1)</sup> Only applies to vehicles without camera-based speed limit display.

- ⑭ **Better route** : if a better route is available for the current route guidance, it will be indicated on the map including the time that would be saved. More information can be found under [⇒ page 218](#).

### Map functions

Applies to: vehicles with navigation system

- ▶ Press the **NAV/MAP** button repeatedly until the map is displayed [⇒ page 213, fig. 192](#).
- ▶ Press the left control button.

The following map functions can be selected:

#### Switch to destination input

The free text search in the **Enter destination** menu is displayed [⇒ page 203, fig. 185](#).

#### Traffic messages

Current traffic information is displayed in the Infotainment system display. You can also find additional information under [⇒ page 217](#).

#### Route list

The route list can only be displayed when route guidance is active and contains information regarding the route, the names of the streets and the length of the route sections. When traveling on highways, possible parking lots and rest areas are shown, which you can select as a stopover.

#### POIs along the route

Requirement: route guidance must be active.

Searching for points of interest along your current route For additional information, see [⇒ page 206](#).

### Additional options on the map

Applies to: vehicles with navigation system

- ▶ Press the **NAV/MAP** button repeatedly until the map is displayed [⇒ page 213, fig. 192](#).
- ▶ Press the right control button.

Depending on the function selected, the following options can also be selected under the **Map** menu:

**Cancel route guidance:** see [⇒ page 208](#).

**Map settings:** see [⇒ page 214](#).

**Route criteria:** see [⇒ page 212](#).

**Voice guidance:** see [⇒ page 212](#).

**Navigation settings:** see [⇒ page 211](#).

**Show alternative routes:** see [⇒ page 210](#).

**Parking along the route\*:** parking options near the vehicle are displayed.

**Save current position:** you can save your current vehicle position as a favorite [⇒ page 211](#) or save it as a contact in the directory [⇒ page 211](#).

**Audi connect at this location\*:** allows you to search for **Travel information** at the entered location (events, weather at the destination, etc.).

**Online traffic data\*:** you can switch the online traffic data on or off ()

**Country information:** see [⇒ page 208](#).

**Avoid route\*:** when route guidance is active, the calculated route will avoid the area you have specified (maximum: 12 mi (20 km)), if possible. The navigation system calculates an alternative route. The route to be avoided that you have entered applies only to the current route and must be set again, if needed. The areas you have selected to avoid will appear with red and white shading on the map.

**Move route\*:** move your finger over the MMI touch control pad\* or use the control knob to adjust the route on the overview map.

### Map settings

Applies to: vehicles with navigation system

- ▶ Press the **NAV/MAP** button repeatedly until the map is displayed.
- ▶ Select: right control button > **Map settings**.

Depending on the selected function, the following settings can be selected:

#### Map colors

**Day/Night:** the map is displayed with a light/dark background. ▶

**Automatic:** the map display adapts to the lighting conditions (for example, changing from **Day** to **Night** when driving through a tunnel).

### Map display

**Standard:** see ⇒ page 213, fig. 193.

**Satellite map**<sup>1)</sup>: see ⇒ page 215, fig. 194.

### Map orientation

**Destination:** the map indicates the destination and is oriented to the north.

**2D heading up map/2D north up map:** the current vehicle position is displayed. The map is oriented in the direction of travel or to the north.

**3D map**\*: the current vehicle position is shown on a three-dimensional map and is aligned to the direction of travel. At a scale of 62 mi (100 km) and larger, the map orientation is to the north.

**Overview map:** the entire route from the vehicle position to the destination or the next stopover is displayed on the map. The map scale depends on the length of the route and adapts automatically. The map is oriented to the north.

### Route information

The display of route information, such as the current street being driven on or points of interest along the current route ⇒ page 213, fig. 192, can be switched on/off or can be minimized on the display of upcoming maneuvers.

### Automatic zoom

**On:** the map scale is adapted automatically depending on the type of road being traveled (expressway, highway, other roads) so that you always have an optimal overview of the road ahead. The scale is also automatically adapted when there are upcoming maneuvers to provide a better detailed view.

**Intersection:** when route guidance is active, the map temporarily zooms in to a detailed scale

when there are upcoming maneuvers so that you can see the street or turn better.

**Off:** the map scale you have chosen is maintained.

### MMI map contents

You can switch the display of additional information on the map in the Infotainment system display on or off.

The weather forecast is displayed on a 3 mi (5 km) scale on the map.

### Instrument cluster map contents

You can also set which map content displays in the instrument cluster ⇒ page 163.

## Satellite map

Applies to: vehicles with a navigation system and Audi connect (Infotainment)

*You can display the navigation map with satellite images.*



Fig. 194 Example: satellite map

Requirement: the requirements for Audi connect services must be met ⇒ page 187.

- ▶ Press the **NAV/MAP** button repeatedly until the map is displayed.
- ▶ Select: right control button > **Map settings** > **Map display** > **Google Earth**<sup>2)1)</sup>.

The map display is based on data received from the Internet in the form of satellite images, which are then combined with the roadways from the **Standard** map view. There are two gigabytes ▶

1) AUDI AG provides access to services from third party providers. Permanent availability cannot be guaranteed, because that depends on the third party provider.

2) Provider at time of printing.

of memory space in the MMI memory that can be used to temporarily store the map or navigation data that was received. This is roughly the amount required for the map/navigation data for a 2,485 mile (4,000 km) route. As long as the satellite images loaded for route guidance are stored, you can use them without having an active data connection.

### Tips

- The stored satellite map<sup>1)</sup> data can be deleted in **Factory settings > Navigation and online memory** ⇒ *page 246*.
- The satellite map<sup>1)</sup> is updated regularly whenever the function is opened. The process may take several seconds.
- When the satellite map display is switched on<sup>1)</sup> with the 3D position map type, the MMI display automatically switches to the 2D map type when driving through tunnels.
- Also read the information in the chapter ⇒ *page 194, Audi connect (Infotainment) general information*.
- For additional information, visit [www.audiusa.com](http://www.audiusa.com).

## Map update

### Introduction

Applies to: vehicles with navigation system

There are multiple options available for updating your map material:

- Map updates through the **online map update\*** ⇒ *page 216*.
- Import map updates from the **SD card\*** to your MMI. You can find additional information online at [www.audiusa.com/myaudi](http://www.audiusa.com/myaudi).
- Map update at an authorized Audi dealer or authorized Audi Service Facility. This can result in additional costs.

### Online map update

Applies to: vehicles with a navigation system and Audi connect (Infotainment)

Using the online map update, you can update the map material in your navigation system directly from your vehicle.



Fig. 195 Example: display of a new online map update



Fig. 196 Example: selection of a country package

Requirement: the requirements for Audi connect Infotainment services must be met ⇒ *page 187*.

You must have a myAudi account and have assigned your vehicle to it.

Using your vehicle position, the MMI identifies regions which you are frequently in. Based on this, the MMI suggests update packages for these regions, if they are available.

- ▶ Select and confirm **1 Start download** ⇒ *fig. 195* if the message for a new map update appears in the Infotainment system display.  
**Or:**
- ▶ Select **MENU** button > **Settings** > left control button > **System maintenance** > **System update** > **Online update**.

<sup>1)</sup> AUDI AG provides access to services from third party providers. Permanent availability cannot be guaranteed, because that depends on the third party provider.

A selection with the available update packages appears in the Infotainment system display ⇒ *fig. 196*.

### Selecting the online map update

- Select an update package from the list (✓) ② ⇒ *fig. 196*.
- Confirm your selection with the **BACK** button and go back to the selection.
- The number and amount of data for the selected update package are now displayed in the Infotainment system.

### Starting the download

- Select and confirm **Start download**.
- Confirm the security prompt by selecting **Start download** again.

The update packages begin to download and the status of the download progress is shown in the Infotainment system display.

### Installation of online map updates

The downloaded map material installs after you stop your vehicle. The new update packages install only after you switch off the ignition. After restarting the MMI, the Infotainment system display indicates if the updates installed successfully.

- Confirm the successful update with **OK**.

The new map material can now be used for navigation.

#### **i** Tips

- Always read the chapter ⇒ *page 187*.
- The amount of available online map updates in the vehicle is limited. To update more regions, use the map update via SD card at [www.audiusa.com/myaudi](http://www.audiusa.com/myaudi).
- Always read the chapter ⇒ *page 194, Audi connect (Infotainment) general information*.

## Traffic information

### Introduction

Applies to: vehicles with navigation system

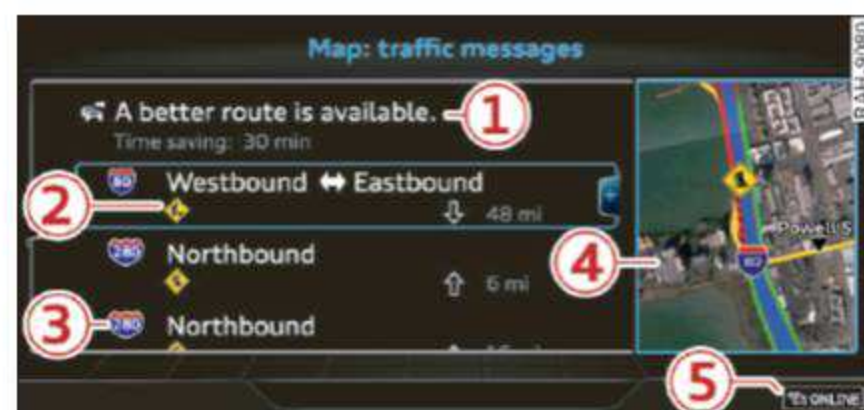

Fig. 197 Example: traffic information overview

- ▶ Press the **NAV/MAP** button repeatedly until the map is displayed ⇒ *page 213, fig. 192*.
- ▶ Select: left control button > **Traffic messages**.

Depending on vehicle equipment, the following information may be shown in the traffic information overview ⇒ *fig. 197*:

- ① A message ① ⇒ *fig. 197* will appear if the MMI calculates a better route for the current route guidance. More information can be found under ⇒ *page 218*.
- ② When route guidance is active, traffic incidents along your route are displayed in the upper section of the list and are sorted by distance.
- ③ The traffic messages are sorted by street name. If there are multiple traffic messages for the same street, an arrow is displayed in front of the street name (▶). Select and confirm the corresponding line to display *all* of the traffic information.
- ④ The current selected traffic message is also shown as a map preview\* in the Infotainment system display.
- ⑤ The status line in the Infotainment display also always indicates the reception of traffic information (**TMC** or **ONLINE**).

**Showing traffic messages on the map:** select: *one traffic message* > right control button > **Show on map**.

**Displaying the next traffic message on the map:** press the control knob. ▶

### Traffic information display on the map/Map preview\*

Color-coded markings along the route indicate the traffic flow:

**Green:** traffic is flowing freely.

**Yellow:** stop-and-go traffic.

**Red:** congestion.

Shaded markings indicate the length of the area with congestion.

**Colored warning symbols:** an impending traffic incident directly ahead on your route.

All traffic incidents will display in color when route guidance is inactive.

**Grayed out warning symbols:** traffic incidents that are not on your route.

**Warning symbols with ↶:** avoided traffic incidents.

The display of colored markings, warning symbols, etc. can be set in the **Map content** menu ⇒ *page 215*.

#### Tips

Particularly critical traffic information, such as warnings about wrong-way drivers, is automatically displayed. To hide the traffic information, press the **BACK** button or the control knob.

### Traffic information (TMC)

Applies to: vehicles with navigation system

Receiving traffic information through TMC is switched on at the factory.

- ▶ Press the **NAV/MAP** button repeatedly until the map is displayed.
- ▶ Select: left control button > **Traffic messages**.

An overview of all the traffic messages is displayed in the Infotainment system.

- **Opening a detailed view of traffic information:** select and confirm the traffic information from the list.

#### Tips

- TMC traffic reports are not available in Canada. For more information, please contact Sirius Canada.
- Critical traffic information, such as warnings about wrong-way drivers, is automatically displayed. To hide the traffic information, press the **BACK** button or the control knob.

### Better route

Applies to: vehicles with navigation system and better route

*By receiving traffic information through TMC, your MMI calculates a better route - if available - and the possible time saved for the current route guidance. You can decide yourself which route you would like to use.*

- ▶ Press the **NAV/MAP** button repeatedly until the map is displayed.

Requirement: route guidance must be active.

If your MMI has calculated a better route than the current route guidance, the message **A better route is available** appears for several seconds along with the time that may be saved. A better route is indicated in the map view by the symbol  ⇒ *page 213, fig. 193*.

A message also appears in the traffic information overview  ⇒ *page 217, fig. 197*.

### Apply better route

- Press the right control button.
- Select and confirm the better route. **Or:** select and confirm **Details** to display details about the optimized route. You can zoom in or out on the map using the MMI touch control pad. Requirement: there must be more than one optimized route calculated. Press the control knob to switch to the next route in the detailed view. **Closing the detailed view:** press the **BACK** button.
- After you have selected a better route, the route will be recalculated.

## Online traffic information

Applies to: vehicles with a navigation system and Audi connect (Infotainment)

The MMI can receive real-time online traffic information about congestion, accidents, road construction and other incidents.

Requirement: the requirements for Audi connect (Infotainment) must be met ⇒ page 187.

- ▶ **Switching online traffic information on and off:** select **NAV/MAP** button > right control button > **Online traffic data on** (☑) or **off** (☐).
- ▶ Press the **NAV/MAP** button repeatedly until the map is displayed.
- ▶ Select: left control button > **Traffic messages**.

The online traffic information will also be displayed on the satellite map <sup>1)</sup> ⇒ page 215 or on the standard map ⇒ page 213, fig. 192.

If **ONLINE** traffic information cannot be received, then traffic information will automatically be received through **TMC** ⇒ page 218.

## Troubleshooting

Applies to: vehicles with navigation system

Problem	Solution
<b>Free text search:</b> the desired destination cannot be found.	The destination might not be entered in the navigation database. <b>Or:</b> check the spelling of the term that was searched. Check if the desired country/state was selected for the free text search using the <b>Country/state selection</b> ⇒ page 204 or the option <b>All countries/states</b> .

### Tips

- Online traffic information is not available in Canada.
- Always read the chapter ⇒ page 194, Audi connect (Infotainment) general information.
- Having the **Online traffic data** function switched on provides the most accurate reports of traffic situations as well as traffic forecasting. Your vehicle transmits and processes its anonymous, encrypted position information at regular intervals to the traffic data provider. If you do not want to use this, you can switch off the **online traffic information** function at any time.
- The **online traffic information** network is currently not available in all countries, and the coverage is not nationwide. For additional information, visit [www.audiusa.com](http://www.audiusa.com).

<sup>1)</sup> AUDI AG provides access to services from third party providers. Permanent availability cannot be guaranteed, because that depends on the third party provider.

## Radio

### Opening the radio

The radio supports the FM, AM and SiriusXM\* (satellite radio) bands. Using the HD Radio receiver also allows you to receive radio stations on the FM and AM bands in digital format.



Fig. 198 FM station list (HD Radio technology FM)



Fig. 199 SiriusXM station list

► Press the **RADIO** button.

After opening the radio, the last opened station list is displayed.

**Selecting a station:** select and confirm a station from the station list. FM/AM stations that can be received by digital radio are marked with the HD Radio technology symbol **HD** ⑤ ⇒ *fig. 198*. If reception quality declines, the radio automatically switches to the analog FM/AM station depending on availability. Digital HD Radio stations\* may contain multiple additional stations\*. The available additional stations\* are listed under the radio station. If you lose reception, the additional stations\* are muted since they can no longer be received.

**Setting the frequency band:** press the **RADIO** button repeatedly until the desired frequency band is set.

The following information is displayed in the station list ⇒ *fig. 198*/⇒ *fig. 199*:

#### ① Presets

The station is stored as a preset. The symbol shows the stored location in the presets list (for example, 21).

#### ② Radio text (shortened display)

If available, program information about the set station is displayed in all of the station lists.

#### ③ Frequency

#### ④ Station name

#### ⑤ Station with HD Radio technology available **HD**

#### ⑥ Channel number

If there is a loss of radio signal (SiriusXM\*), the following system information is displayed in the station list:

**NoSignal:** the tuner is currently not receiving a satellite signal ⑦.

The system information turns off when the radio stations are received again.

#### **i** Tips

- Contact the SiriusXM\* provider if you would like to receive satellite programming.
- Buildings, tunnels, bridges, open areas, other vehicles or objects on the vehicle roof can affect reception.
- Satellite radio is not available in Alaska and Hawaii.

## Radio functions

### Free text search

Applies to: vehicles with free text search

Using the free text search, you can select the order that the search terms are entered in the input field. Search in all frequency bands for a station name or program type, such as **News**.



Fig. 200 Input field and results list for free text search

- **Opening the free text search:** when in a station list, keep turning the control knob to the left until the **free text search** input field is displayed.
- **Using the free text search:** see ⇒ page 157, *Free text search*.

You can also search for frequencies.

Stations from the presets ③ are displayed in the results list ① ⇒ fig. 200. The symbol ② indicates which station list you switched to based on the station selection.

### Additional options

- ▶ Select: **RADIO** button > right control button.

The following options are available depending on the frequency band:

- **Sound settings:** see ⇒ page 249.
- **Store as favorite:** see ⇒ page 223, *Presets*.
- **Manage SiriusXM alerts:** see ⇒ page 222, *SiriusXM alerts*.
- **Store artist as favorite/Store track as favorite:** see ⇒ page 222, *SiriusXM alerts*.
- **Manual tuning:** the frequency bars are displayed. Select and confirm the desired frequency.
- **Seek:** the radio tunes to the previous or next receivable station.

- **Scan:** all stations are played for several seconds each.
- **Radio settings:** see ⇒ page 223.

### Radio text

- ▶ Select: **RADIO** button > left control button > a frequency band (such as **FM**) > a station.
- ▶ Select: right control button > **Radio text**.

Information that accompanies the program (such as artist, composer, track) is displayed.

**Browsing through radio text entries:** turn the control knob to the left or right.

Requirement: a radio text entry must be displayed and the station must be broadcasting a phone number, a navigation destination or a text message number as Radio Text Plus information.

If a location, a phone number or a text message number is included with a radio text entry, the radio text will be shown with a colored border. You have the following options:

**Call\*/Start route guidance\*/Write text message\*:**

- Select a radio text entry with Radio Text Plus information and press the control knob.
- Select and confirm **Call\*/Start route guidance\*/Write text message\***. Or: press the **BACK** button to cancel.

### **i** Tips

The availability of radio text and Radio Text Plus depends on the radio station.

**SiriusXM alerts**

Applies to: vehicles with SiriusXM

You can display an overview of your favorite artists or tracks that are currently being played on a SiriusXM channel.



Fig. 201 SiriusXM alert notification

- ▶ Select: **RADIO** button > left control button > **SiriusXM**.

After you have stored a SiriusXM alert for your favorite tracks or artists, you can display an overview of your favorite tracks or artists currently being received in the **SiriusXM alerts** menu and play them immediately. You can also receive a *SiriusXM alert notification* ① for these tracks or artists in the entertainment sliding menu ⇒ fig. 201.

**Storing a SiriusXM alert**

Requirement: your favorite track or artist must be playing on a SiriusXM channel.

- Select: right control button > **Store track as favorite** or **Store artist as favorite**.

**Switching SiriusXM alert notifications on and off**

- Select: right control button > **SiriusXM alert notifications**.

When the function is switched on , a *SiriusXM Alert notification* ① ⇒ fig. 201 is displayed for several seconds in the entertainment sliding menu for the **Radio** and **Navigation** menus.

**Playing tracks/artists from Sirius XM alerts**

Requirement: a SiriusXM alert must be stored for a track/artist and it must be currently playing on a SiriusXM channel.

- Select: left control button > **SiriusXM alerts** > an entry from the list. The selected track/artist is played.

**Playing tracks/artists from the entertainment sliding menu**

Requirement: the **SiriusXM alert notifications** function must be switched on. You must be in the **Radio** and **Navigation** menu. A *SiriusXM alert notification* is displayed in the entertainment sliding menu ① ⇒ fig. 201.

- Push the control knob down.
- Select and confirm the desired track/artist.

**Managing SiriusXM alerts**

- Select: right control button > **Manage SiriusXM alerts**.
- **Switching SiriusXM alerts on/off:** when the function is switched on , you are notified when this track or artist is being played on a SiriusXM channel.
- **Deleting Sirius XM alerts:** select an entry from the list > right control button > **Delete from alerts** > **Delete this entry** or **Delete all entries**.

**View: additional station information**



Fig. 202 Radio view: additional station information

Requirement: you must be tuned to a radio station. The **Show "Now Playing" screen** option must be switched on ⇒ page 224.

Symbols in the "Now Playing" screen ⇒ fig. 202:

- ① Radio text availability

**Radio text** is available for the selected station.

See ⇒ *page 221*.

#### ④ Screen view

Display **Cover art** or **Station logo**. See ⇒ *page 224, Preferred picture view\**.

#### Displaying the station list:

Turn the control knob. **Or:** press the **BACK** button.

## Radio menu



Fig. 203 Example: Radio menu

► Select: **RADIO** button > left control button.

**Setting the frequency band:** select and confirm the desired frequency band in the radio menu ⇒ *fig. 203*. **Or:** press the **RADIO** button repeatedly until the desired frequency band is set. The station list is displayed.

#### ① Presets

The presets list is displayed ⇒ *page 223, Presets*.

#### ② SiriusXM alerts

Applies to: vehicles with SiriusXM alerts

After you have stored a SiriusXM alert for your favorite tracks or artists ⇒ *page 222*, an overview of your favorite tracks or artists currently being received on SiriusXM is displayed.

#### ③ SiriusXM

Applies to: vehicles with SiriusXM alerts

The **SiriusXM\*** station list is displayed.

#### Additional frequency bands

Depending on the vehicle equipment, you may also be able to select additional frequency bands

④/⑤ ⇒ *fig. 203* in the selection menu.

## Presets

You can store your favorite stations from every frequency band in the presets list.

► Select: the **RADIO** button > left control button > **Presets**.

Requirement: the presets list must be displayed.

- **Storing presets:** select and confirm a free preset space. Follow the system instructions.
- Select and confirm a station from the list if necessary.

Requirement: a station list must be displayed.

- **Storing presets:** select: an entry from the list > right control button > **Store as preset**. **Or:** press and hold the control knob for several seconds.

The shortcut keys are automatically assigned to the presets 1 to 8. You can select the stations directly using the preset buttons ⇒ *page 155*.

- **Displaying the presets list:** select: **RADIO** button > **Presets**.

Requirement: the presets list must be displayed.

- **Listening to presets:** select and confirm a preset from the list.
- **Move favorite:** select a favorite from the list > right control button > **Move favorite**. **Or:** press and hold the control knob for several seconds. Select and confirm the location of the selected preset.
- **Deleting presets:** select a preset from the list > right control button > **Delete preset** > **Delete this preset** or **Delete all presets**.

## Additional settings

### Radio settings

► Select: **RADIO** button > right control button > **Radio settings**.

The following settings can be selected, depending on the band that is selected: ►

### Station names (FM)

**Variable:** scrolling text transmitted by the FM stations is shown in the Infotainment system display.

**Fixed:** scrolling text transmitted by the FM stations is not shown in the Infotainment system display. Only the current section of the scrolling text is displayed.

### FM/AM HD Radio\*

You can switch HD Radio reception on or off.

### Channel sorting (SiriusXM\*)

You can set the station sorting for SiriusXM station lists\* by:

- **Channel number:** the channels are sorted in ascending order according to their channel number.
- **Channel name:** the channels are listed in alphabetical order.
- **First category, then channel number:** the channels are sorted by their category and then by their channel numbers.
- **First category, then channel name:** the channels are sorted by their category and then by their channel names.

### Category filter (SiriusXM\*)

The stations shown in the station list can be filtered by your personal preferences and by program type. The program categories that you can select depend on what is offered by your provider. Select the **All categories** option to deactivate all filter options and display all available stations in the satellite station list.

## Troubleshooting

Problem	Solution
A station with poor reception is no longer displayed in the station list once you switch to a different station.	Store the station as a preset in advance. Access the presets using the presets list ⇒ <i>page 223</i> .

### Show "Now Playing" screen

When the function is switched on  and the stations or presets list is open, the display will switch to the **Show "Now Playing" screen** view after approximately five seconds ⇒ *page 222*. Depending on availability, information about the set station (such as station name, artist and station logo) may be displayed in this view.

### Preferred picture view\*

You can set your preferred screen view for the **Show "Now Playing" screen** ⇒ *page 222*.

- **Station logo:** the station logo is displayed, depending on availability.
- **Cover art:** the album cover is displayed if available.

### Gracenote online database\*

Requirement: the MMI must be connected to the Internet. The **Cover art** option must be selected ⇒ *page 224*, **Preferred picture view\***.

When the function is switched on , the album cover or genre cover for the song that is playing is loaded from the Gracenote online database, depending on availability.

### Subscription status (SiriusXM)\*

This option is available when your subscription is about to expire or has already expired. The expiration date for your license is displayed.

**Call to SiriusXM\*:** the contact information for your satellite radio provider is displayed. To call your satellite radio provider using the MMI, press **Call to SiriusXM\***.

## Media

### Introduction

There are various media drives and connections available in the MMI. For example, you can play audio/video\* files from the Jukebox\* or connect your mobile device to the Audi music interface\* and operate it through the MMI.

### Notes

#### General

**Media and format restrictions:** the MMI (including the SD card reader and the USB storage device connection\*) was tested with a variety of products and media on the market. However, there may be cases where individual devices or media and audio/video files\* may not be recognized, may play only with restrictions, or may not play at all.

**Digital Rights Management:** please note that the audio/video\* files are subject to copyright protection.

The media drives do not play files that are protected by DRM and that are identified with the symbol .

**Data security:** never store important data on SD cards, the Jukebox\*, CDs/DVDs or mobile devices. Audi AG is not responsible for damaged or lost files and media.

**Loading times:** the more files/folders/playlists that are on a storage medium, the longer it will take to load the audio/video\* files. Audi recommends using storage media that only contain audio/video files\*. To decrease the time it takes to load audio/video files\*, create subfolders (for example, for the artist or album). The loading time will also increase when importing files.

**Additional information:** when playing, audio files are automatically displayed with any additional information that is stored (such as the artist, track and album cover). If this information is not available on the storage medium, the MMI will check the Gracenote metadata database.

However, in some cases, the additional information may not be displayed.

**Restricted functionality:** reset the **Media settings** to the factory default settings if functionality is restricted ⇒ *page 246*.

If functionality is restricted, reset the **Jukebox\*** to the factory default settings ⇒ *page 246*.

For information about the properties of supported media and file formats, see ⇒ *page 240*.

#### Note

Always follow the information found in ⇒  in *Wi-Fi hotspot on page 194*.

#### CD/DVD operation

**CD/DVD and format restrictions:** the functionality of individual storage media may be limited due to the variety of blank CDs/DVDs available and the various capacities. Audio CDs or video DVDs with copy protection, CDs/DVDs that do not conform to the standard and multisession CDs may have limited playback or may not play at all. Audi recommends finalizing the recording process when creating multisession CDs. Multisession is not supported for DVDs.

**Using CDs/DVDs, the CD drive or the DVD drive:** to ensure correct, high-quality playback and to prevent damage to the drive or disc reading errors, always store CDs/DVDs in a protective sleeve and do not expose them to direct sunlight. Do *not* use:

- Damaged, dirty or scratched CDs/DVDs
- Single CDs/DVDs with 3 in (8 cm) diameter
- CD/DVDs that are not round
- CDs/DVDs with labels
- Protective rings
- Cleaning CDs

**Thermal protection switch:** CD/DVD playback may be temporarily unavailable if outside temperatures are extremely hot or cold. A thermal protection switch is installed to protect the CD/DVD and the laser.

**Laser devices:** laser devices are divided into safety classes 1 to 4 in accordance with DIN IEC 76 ▶

(CO) 6/VDE 0837. The optical readers that are installed conform to safety class 1. Lasers in this class are very weak and well shielded, so there is no danger if used correctly.

## Media drives

### SD card reader

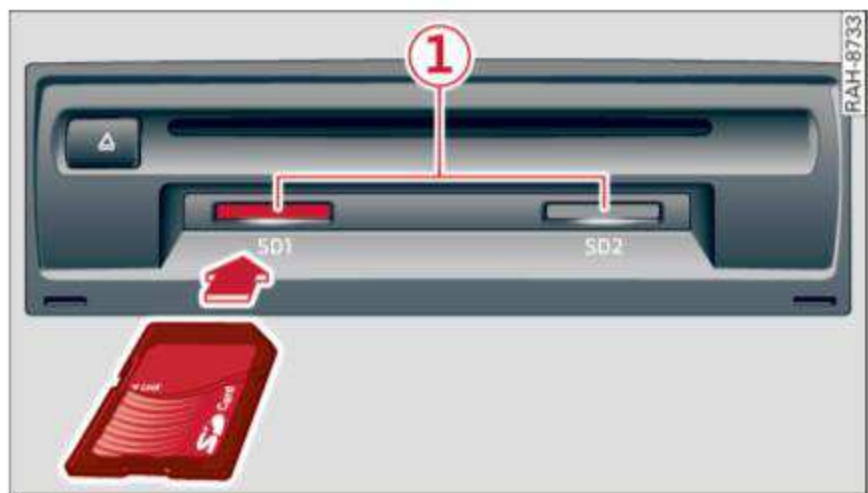

Fig. 204 Glove compartment: SD card reader

- **Inserting the SD card:** the angled corner of the SD card must face toward the right front. Slide the SD card into the card reader slot ① ⇒ *fig. 204* until the SD card clicks into place.
- **Automatic playback:** playback will start automatically if the inserted SD card contains supported audio/video files\* ⇒ *page 240*.
- **Removing the SD card:** press briefly on the SD card.

The SD card reader is accessed and operated through the MMI ③ ⇒ *page 234, fig. 210*.

**! Note**  
Only use one-piece SD cards. If adapter cards (SD cards with more than one piece) are used, the card could fall out of the adapter when driving because of vibrations. Individual pieces could then become stuck in the drive and impair the functionality.

**i Tips**  
The SIM card reader then does not function.

### DVD drive

Applies to: vehicles with a DVD drive

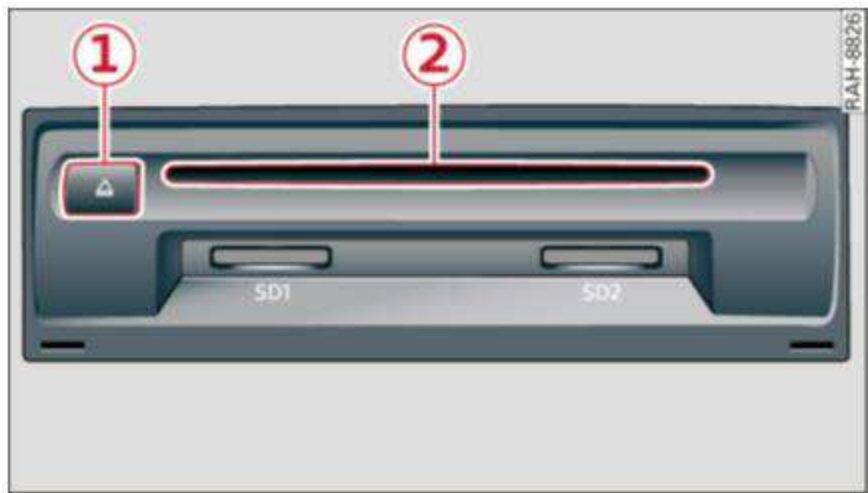

Fig. 205 Glove compartment: DVD drive

- **Loading a CD/DVD:** the CD/DVD is pulled in automatically. Slide the CD/DVD straight into the DVD slot ② with the label facing up ⇒ *fig. 205*.
- **Automatic playback:** playback will start automatically if the inserted CD/DVD contains supported audio/video\* files ⇒ *page 240*.
- **Ejecting a CD/DVD:** press the button ① ⇒ *fig. 205*.

The CD/DVD is pulled in again automatically if it is not removed from the DVD slot within approximately ten seconds after ejecting it.

The DVD drive is accessed and operated through the MMI ② ⇒ *page 234, fig. 210*.

**! Note**  
– Never force a CD/DVD into the drive. The CD/DVD is pulled in automatically.  
– Do not insert CDs/DVDs with labels into the drive. Labels can come loose from the CD/DVD and damage the drive.

**i Tips**  
– The CD/DVD playback is not ensured with audio files that have a high data rate.  
– The SIM card reader then does not function.

## CD drive

Applies to: vehicles with a CD drive

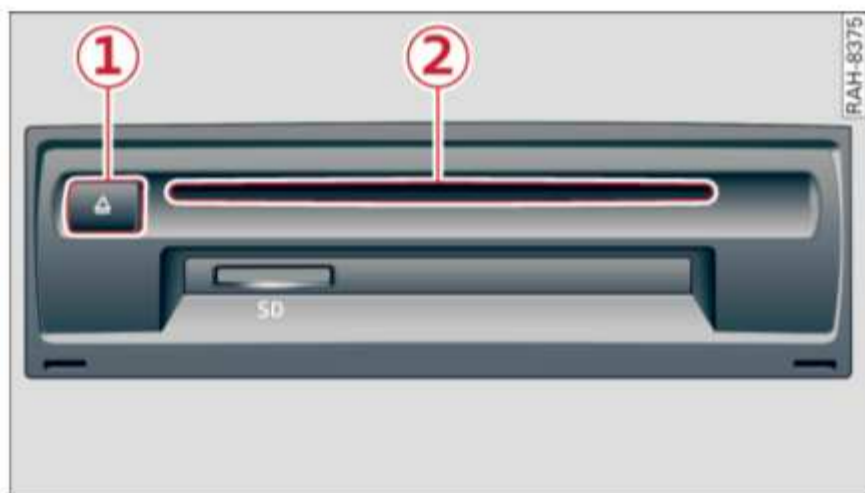

Fig. 206 Glove compartment: CD drive

- **Loading a CD:** the CD is pulled in automatically. Slide the CD straight into the CD slot ② ⇒ *fig. 206* with the label facing up.
- **Automatic playback:** playback will start automatically if the inserted CD contains supported audio files ⇒ *page 241, CD drive*.
- **Ejecting a CD:** press the button ① ⇒ *fig. 206*.

The CD is pulled in again automatically if it is not removed from the slot within ten seconds of ejecting it.

The CD drive is accessed and operated through the MMI ⇒ *page 234*.

### ! Note

- Never force a CD into the drive. The CD is pulled in automatically.
- Do not insert CDs with labels into the drive. Labels can come loose from the CD and damage the drive.

### i Tips

CD playback cannot be guaranteed with audio files that have a high data rate.

## Jukebox

Applies to: vehicles with Jukebox

After you have filled the Jukebox with music and/or videos, for example from your SD card, you can play these files directly from the Jukebox. The Jukebox memory capacity is approximately 10 GB.

- ▶ Press the **MEDIA** button. Press the left control button until the sources overview ⇒ *page 234* is displayed. Select and confirm **Jukebox**.

### Adding files to the Jukebox

- Press the **MEDIA** button. Press the left control button until the sources overview ⇒ *page 234* is displayed. Select one of the following sources to copy to the Jukebox: SD card\*, CD-ROM\*, DVD-ROM\*, USB storage device\*.

Requirement: the media center (for example, tracks, albums) must be open.

- **Selecting an entry:** select an entry from the media center. Select: right control button > **Copy to Jukebox** > **This entry** or **Entire list**.

Requirement: the playlist must be open. See ⇒ *page 237*.

- **Selecting a track:** select the track that is currently playing. Select: right control button > **Copy to jukebox** > **This track** or **Entire album** or **This artist**.

Requirement: a video file must be playing.

- Select: right control button > **Copy to Jukebox**.

The copying process begins. The status of the copying process is shown in the MMI.

- **Hiding the importing process:** select and confirm **Continue copying in background**. The importing process is hidden.
- **Canceling the importing process:** select and confirm **Cancel copying**: Or: remove the source that is being imported. Files already copied remain.

Requirement: the copying process must be active in the background.

- **Showing the copying process:** select: right control button > **Copying in progress**. ▶

When importing, the audio files are automatically sorted into the media center categories based on the stored additional information

⇒ *page 235*. The copied video files are stored in the media center under the **Videos** category.

### Playing the Jukebox

Requirement: the Jukebox must contain audio/video files ⇒ *page 227, Adding files to the Jukebox*.

The Jukebox is accessed and operated through the MMI ① ⇒ *page 234, fig. 210*.

### Displaying Jukebox memory capacity

Select: right control button > **Jukebox memory capacity**. Information about the Jukebox memory capacity and the number of stored tracks is displayed.

### Deleting tracks from the Jukebox<sup>1)</sup>

Requirement: the Jukebox must contain audio/video files.

- **Deleting an entry:** select an entry from the Jukebox media center. Select: right control button > **Delete from jukebox** > **This entry** or **Entire list**.
- The status of the deleting process is shown in the MMI. Jukebox playback stops during the deleting process and starts again automatically once the deletion is complete.

#### Note

Do not import audio/video files when the engine is turned off because this will drain the vehicle battery.

#### Tips

- Tracks from audio CDs cannot be imported to the Jukebox for legal reasons.
- Files that have already been imported are automatically recognized and cannot be copied to the Jukebox again.
- It is not possible to play audio/video\* files in the CD/DVD\* drive while importing them.

- The Jukebox does not provide an export function due to legal reasons.
- Files or tracks without additional stored information are listed as **Unknown**. Audi recommends adding additional information (such as ID3 tags) to audio files.
- Reset the **Jukebox** to the factory default settings when selling your vehicle ⇒ *page 246*.

## Bluetooth audio player

Applies to: vehicles with Bluetooth audio player

*With the Bluetooth audio player, you can play music wirelessly from your Bluetooth-capable device (such as a cell phone) through the MMI.*

Requirement: the vehicle must be stationary and the ignition must be switched on. The Bluetooth settings will open on your mobile device during the connection setup. The Bluetooth function and visibility of the MMI ⇒ *page 248* and mobile device must be switched on. The **Bluetooth audio player** ⇒ *page 248* must be switched on in the MMI.

- **Connecting a Bluetooth player:** press the **MEDIA** button. Press the left control button until the sources overview is displayed. Select and confirm **Bluetooth audio player** ⑥ ⇒ *page 234, fig. 211*.
- If necessary, select and confirm, **Not connected** > **Connect Bluetooth audio player**. The Bluetooth device search starts. Follow the instructions in the MMI.
- Select and confirm the desired Bluetooth device from the list. The MMI generates a PIN for the connection.
- Select and confirm **Yes**.
- Enter the PIN for connecting on your Bluetooth device. **Or:** if the PIN is already displayed on your Bluetooth device, confirm it in the Bluetooth device and in the MMI. The time allowed for entering the PIN is limited to approximately 30 seconds. ▶

<sup>1)</sup> Not in the **Playback** view.

The media is started and operated through the mobile device or the MMI, depending on the device being used.

### Tips

- Check for any connection requests on your Bluetooth device.
- Multiple Bluetooth audio players can be connected to the MMI, but only one mobile device can be active.
- Bluetooth protocols AVRCP (1.0/1.3/1.4) and A2DP are supported.
- Note the volume setting on your Bluetooth device. Audi recommends setting your mobile device to the maximum volume when using it as a Bluetooth audio player.
- The supported media functions (such as shuffle) depend on the Bluetooth device being used.
- For more information on the supported devices, visit [www.audiusa.com/bluetooth](http://www.audiusa.com/bluetooth) or contact an authorized Audi dealer or authorized Audi Service Facility.

## Wi-Fi audio player

Applies to: vehicles with Wi-Fi audio player

*Using the Wi-Fi audio player media source on the MMI, you can connect and operate your Wi-Fi-capable media player (such as a smartphone) to wirelessly play music from your media player library. The media player is connected through the vehicle's Wi-Fi hotspot. A UPnP Server app or an integrated UPnP/DLNA server on your media player is required to access your media player library.*

Requirement: the Wi-Fi function on your media player must be switched on. The **Audi MMI connect** app or a UPnP server app must be installed on your media player. **Or:** you must be using a media player with an integrated UPnP/DLNA server.

- **Connecting a media player:** press the **MEDIA** button. Press the left control button until the sources overview  $\Rightarrow$  page 234 is displayed. Select and confirm **Wi-Fi audio player**   $\Rightarrow$  page 234, fig. 211.

- If necessary, select and confirm **Wi-Fi turned off** > **Turn on Wi-Fi** to activate Wi-Fi in the MMI. Select **Wi-Fi settings**, if necessary. Select the same settings on the wireless media player that are used for the Wi-Fi hotspot.
- **Starting the Wi-Fi audio player:** start the **Audi MMI connect** app or a UPnP server app, or set media permissions on your media player.

**Operating the media player:** the media player is operated through the MMI.

- Press the left control button repeatedly until the **Folders** menu item appears. Select and confirm **Folders**.
- **Playing music from the media player:** select and confirm **Media center**.

**Web radio:** see  $\Rightarrow$  page 230.

### WARNING

- As the driver, do not allow usage of the Wi-Fi hotspot to distract you from driving, as this could increase the risk of an accident.
- It is only safe to use tablets, laptops, mobile devices and other similar devices when the vehicle is stationary because, like all loose objects, they could be thrown around the inside of the vehicle in a crash and cause serious injuries. Store these types of devices securely while driving.
- Do not use any wireless devices on the front seats within range of the airbags while driving. Also read and follow the warnings in  $\Rightarrow$  page 273, *Front airbags*.

### Note

Always follow the information found in  $\Rightarrow$   in *Wi-Fi hotspot* on page 194.

### Tips

- Always read the chapter  $\Rightarrow$  page 194, *Audi connect (Infotainment) general information*.
- Please note that a Wi-Fi connection does not automatically make it possible to use the Internet. For additional information, see  $\Rightarrow$  page 187.

- To avoid interruptions during playback, deactivate the power saving function on the media player or connect it to a charger.
- The loading times for the audio data depend on the media player used and the number of files that it contains.
- A maximum of 2,000 entries per directory are displayed in the MMI.
- Songs downloaded for offline use using music streaming services are stored on your mobile device (such as a smartphone) and may be DRM protected. The Wi-Fi audio player will not play DRM protected files.
- Contact an authorized Audi dealer or authorized Audi Service Facility for additional information on the Wi-Fi audio player.

## Online media and Internet radio

Applies to: vehicles with Audi connect

*You can playback and operate various online media services and Internet radio using the MMI.*

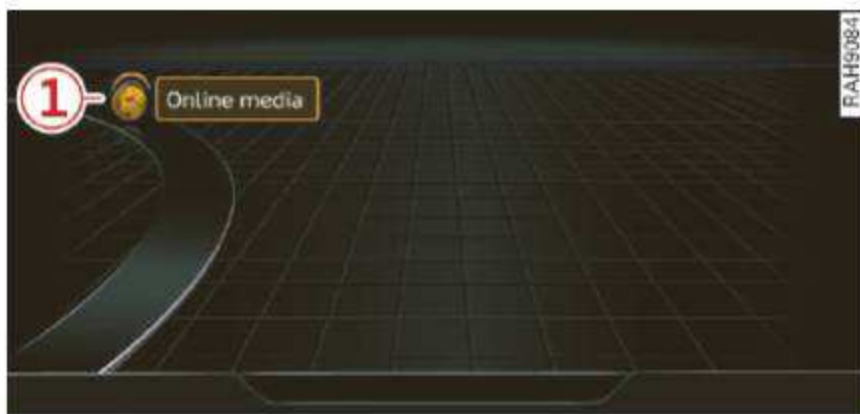

Fig. 207 Online media

- ▶ Press the **MEDIA** button. Press the left control button until the sources overview ⇒ *fig. 207* is displayed.

Applies to: using online media and Internet radio

Requirement:

- The **Audi MMI connect** app must be installed and open on your mobile device.
- You must be logged into your myAudi account in the **Audi MMI connect** app and you must have selected your vehicle.
- The Wi-Fi function on the mobile device and on the MMI must be switched on.
- If necessary, check in the connection manager ⇒ *page 246* if the mobile device you connected is selected under the **MMI connect app** (✓).

- The MMI must be connected to the network.
- The symbol for the **Online media** source ① ⇒ *fig. 207* is shown in the MMI.

Applies to: using online media

Additional requirement:

- A supported online media service must be available in your country.
- You must have an account with a supported online media service.
- Depending on the online media service, you must install and open an app on your mobile device.

### Starting Online media

- Press the **MEDIA** button. Press the left control button until the sources overview ⇒ *page 234* is displayed.
- Select and confirm an online media service.

### Starting Internet radio

- Press the **MEDIA** button. Press the left control button until the sources overview ⇒ *page 234* is displayed.
- Select and confirm **Internet radio**. The Internet radio browser or the last station that was playing is shown.
- **Selecting the station:** if necessary, select and confirm a category in the Internet radio **Browser** > *a station*.

### Online media and Internet radio: additional options

- Press the right control button.

The following options may be available, depending on the information shown (such as the station/track that is currently playing):

- **Sound settings:** see ⇒ *page 249*.
- **Wi-Fi settings:** see ⇒ *page 193, Wi-Fi hotspot*.
- **Connection manager:** see ⇒ *page 246*.
- Additional options may be available, depending on the active online media service or Internet radio.

### ⚠ WARNING

- It is only safe to use tablets, laptops, mobile devices and other similar devices when the vehicle is stationary because, like all loose objects, they could be thrown around

the inside of the vehicle in a crash and cause serious injuries. Store these types of devices securely while driving.

- Do not use any wireless devices on the front seats within range of the airbags while driving. Also read and follow the warnings in ⇒ *page 273, Front airbags.*

### ! Note

- Always follow the information found in ⇒ ! in *Wi-Fi hotspot on page 194.*
- Please note that there generally are additional costs when using an online media service account, especially when it is used internationally.

### i Tips

- Depending on the Internet connection and network traffic, a connection loss can occur during playback of online media services.
- **Online media** and **Internet radio** usage depends on the service availability of the third party provider.
- Audi AG simply makes the access to online media services possible through the MMI and does not take any responsibility for the contents of the online media services.
- Always read the chapter ⇒ *page 194, Audi connect (Infotainment) general information.*
- Depending on the mobile device used, there may be interruptions during media playback and when using the **Audi MMI connect** app. To avoid interruptions when using a mobile device, do not lock the screen on your mobile device and keep the **Audi MMI connect** app in the foreground.
- Contact an authorized Audi dealer or authorized Audi Service Facility for additional information about online media.

## Multimedia connections

### USB adapter for Audi music interface or USB charging port

Depending on the vehicle equipment, you can connect your mobile devices (such as a smartphone or MP3 player) to the Audi music interface or a USB charging port using a special USB adapter.

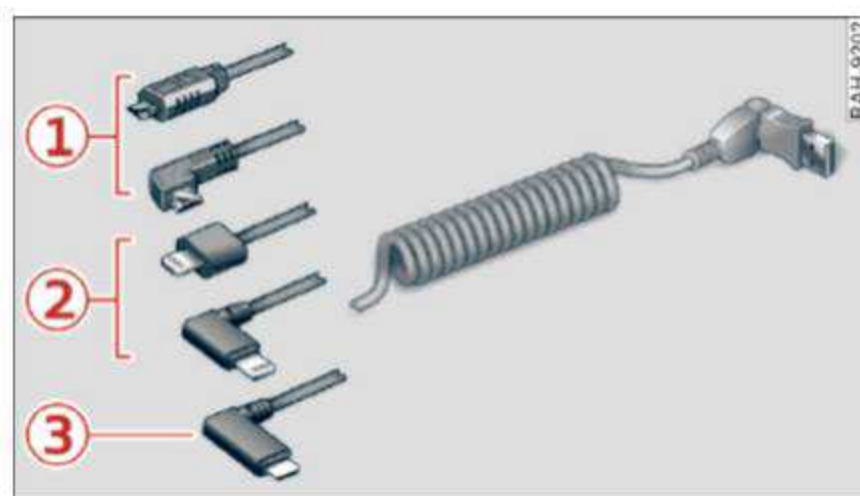

Fig. 208 Audi Genuine Accessories: USB adapter

You can purchase the USB adapter ⇒ *fig. 208* from an authorized Audi dealer or at specialty stores:

- ① USB adapter for devices with a micro USB connection
- ② USB adapter for devices with an Apple Lightning connection
- ③ USB adapter for devices with USB type C connection

Depending on the vehicle equipment, you may be able to connect your mobile devices through the Audi music interface to the MMI using the USB adapters and charge the battery at the same time.

Applies to: vehicles with Audi music interface

- **Audi music interface:** see ⇒ *page 232.*

Applies to: vehicles with USB charging ports in the rear

- **USB charging ports in the rear:** see ⇒ *page 233.*

### ! Note

Handle the USB adapter carefully. Do not allow it to be pinched.

### **i** Tips

- The USB adapter on the Audi music interface will support iPod touch/iPhone from the 5th generation or later with the lightning connector.
- Mobile devices with an Apple Dock connector can only be charged with a USB adapter for devices with an Apple Dock connector and cannot transmit data.

## Audi music interface

Connect your mobile devices to the Audi music interface in order to operate them through the MMI and charge the battery.



Fig. 209 Storage compartment under the center armrest and at the front\* of the center console: diagram: Audi music interface

### USB Input

- **Connecting a mobile device using a USB adapter:** connect the applicable USB adapter (2) ⇒ fig. 209 to the port on the Audi music interface (3) ⇒ fig. 209 or in the front of the center console\* and then connect the adapter to the mobile device (1) (such as an iPhone).
- **Charging a mobile device using a USB adapter:** when you connect a mobile device to the Audi music interface (3) ⇒ fig. 209 or at the front of the center console\* using the applicable USB adapter (2) ⇒ fig. 209, the battery will automatically charge.
- **Disconnecting a mobile device from the Audi music interface:** remove the USB adapter (2) ⇒ fig. 209 from the Audi music interface.

The media are started and operated through the mobile device or the MMI, depending on the device being used ⇒ page 234.

**Connecting multiple mobile devices:** if a mobile device (such as a smartphone) is connected at the respective USB port on the Audi music interface, then all devices can be used as a playback source.

### AUX Input

- **Connecting a mobile device to the AUX input:** connect the cable (5) ⇒ fig. 209 to the AUX input (6) on the Audi music interface and then to the mobile device (4) (such as an MP3 player or smartphone).
- **Disconnecting a mobile device from the AUX input:** remove the cable (5) ⇒ fig. 209 from the AUX input (6) ⇒ fig. 209.
- **Operation:** select and confirm the **External audio player** source (5) ⇒ page 234, fig. 210. The media are started and operated through the mobile device (4) ⇒ fig. 209.

### **!** WARNING

Driving requires your complete and undivided attention. As the driver, you have complete responsibility for safety in traffic. Never operate mobile devices while driving, because this increases the risk of an accident.

### **!** Note

- Use a USB extension cable to connect devices that have an integrated USB connector (such as a USB stick) to prevent damage to your USB device and the Audi music interface.
- Extremely high or low temperatures that can occur inside vehicles can damage mobile devices and/or impair their performance. Never leave mobile devices in the vehicle in extremely high or low temperatures.

### **i** Tips

- Always follow the information found in ⇒ page 60.
- When you switch the ignition off, the USB ports are still supplied with power until the energy management intervenes.
- Do not use an additional adapter or USB extension cable to connect mobile devices to the Audi music interface that already have a cable or that must be connected with a USB

adapter (⇒ page 231). They may impair the functionality.

- You can purchase the AUX connector cable from an authorized Audi dealer or at specialty stores.
- Audi recommends setting the volume of a mobile device connected to the AUX input to approximately 70% of the maximum volume.
- Functionality is not guaranteed for mobile devices that do not conform to the USB 2.0 specification.
- USB hubs are not supported.
- Some versions of the iPod such as the iPod shuffle cannot be connected to the USB adapter for devices with Apple Dock connector. Connect these devices using a AUX connector cable.
- Changed content on a mobile device <sup>1)</sup> that is connected to the Audi music interface may not be displayed in the media center. In this case, reset the **Media settings** back to **Factory settings** ⇒ page 246.
- Video playback through the Audi music interface is only supported if the connected device is recognized as a USB storage device (for example a USB stick). Apple devices and MTP devices (such as smartphones) are not recognized as USB storage devices.
- iPod/iPhone malfunctions also affect the operation of the MMI. Reset your iPod/iPhone if this happens.
- Audi recommends updating the iPod/iPhone software to the latest version. For important information on operating your iPod/iPhone, refer to the user guide for the device.
- The USB adapter on the Audi music interface will support iPod touch/iPhone from the 5th generation or later with the lightning connector.
- For more information about the Audi music interface and supported devices, check the Audi database for mobile devices at [www.audiusa.com/mp3](http://www.audiusa.com/mp3) or contact an au-

thorized Audi dealer or authorized Audi Service Facility.

### USB charging ports in the rear

Applies to: vehicles with USB charging ports in the rear

*You can charge the battery on your mobile device through a USB charging port.*

Two USB charging ports are located at the back of the center console.

- **USB adapter:** refer to ⇒ page 231, *USB adapter for Audi music interface or USB charging port.*
- **Charging a mobile device using the USB adapter:** connect your mobile device to a USB charging port using a suitable USB adapter.
- **Disconnecting a mobile device from the charging port:** remove the USB adapter from the USB charging port.
- **Disconnecting mobile devices with an Apple Dock connector:** remove the Apple Dock connector from the Apple device with the release tabs pressed in.



### WARNING

Driving requires your complete and undivided attention. As the driver, you have complete responsibility for safety in traffic. Never operate your mobile devices while driving, because this increases the risk of an accident.



### Note

Extremely high or low temperatures that can occur inside vehicles can damage mobile devices and/or impair their performance. Never leave mobile devices in the vehicle in extremely high or low temperatures.



### Tips

- In preparation at the time of printing.
- Always follow the information found in ⇒ page 60.
- When you switch the ignition off, the USB ports are still supplied with power until the energy management intervenes.

<sup>1)</sup> Applies only to MTP devices. Does not apply to Apple devices and USB mass storage devices.

- Do not use any additional USB extension cables or adapters to connect mobile devices to the USB charging port that have already been connected by a USB adapter. They may impair the functionality.
- USB hubs are not supported.
- Refer to the manufacturer's operating manual for important information regarding the operation of your mobile device.
- Correct function of all mobile devices cannot be guaranteed.
- The vehicle battery drains when mobile devices are turned on but the engine is off.

## Playing media

### Accessing media

You can start and operate various media through the MMI control panel.



Fig. 210 Diagram: possible sources in the Media menu



Fig. 211 Diagram: possible sources in the Media menu

### Rear Seat Entertainment preparation

Applies to: vehicles with Rear Seat Entertainment preparation

The *Rear Seat Entertainment preparation* includes cables and a mount for Audi Entertainment mobile in the driver's and front passenger's seat backrests.

The suitable **Audi Entertainment mobile** Rear Seat Entertainment package is available through Audi Genuine Accessories.

Using Audi Genuine Accessories is recommended. Audi has established their reliability, safety and suitability.

We cannot evaluate or endorse other products in this way, even if the product is approved by a certified testing agency or government agency .

Requirement: a media source must contain audio/video\* files ⇨ *page 226*.

- ▶ Press the **MEDIA** button. Press the left control button until the sources overview is displayed.
- ▶ Select and confirm the desired source. **Or:** press the **MEDIA** button repeatedly until the desired source is selected.

Depending on the vehicle equipment, the following sources may be displayed in the **Media** menu:

①	<b>Jukebox*</b> .....	227
②	<b>DVD/CD drive*</b> .....	226, 227
③	<b>SD card reader</b> .....	226
④	<b>Audi music interface*</b> .....	232
	such as an iPhone, USB stick	
⑤	<b>External audio player</b> .....	232
	such as an MP3 player connected to the AUX input	
⑥	<b>Bluetooth audio player*</b> .....	228
⑦	<b>Wi-Fi audio player*</b> .....	229
⑧	<b>Online media*</b> and <b>Internet radio*</b> ..	230 ▶

### ! Note

Only use devices that are approved for the Rear Seat Entertainment preparation. Unapproved devices may cause damage to the vehicle electronics.

### i Tips

- Contact an authorized Audi dealer or authorized Audi Service Facility for additional information about **Audi Entertainment mobile**.
- Always read the chapter ⇨ *page 371*.
- The **Rear Seat Entertainment** preparation is not intended to charge external electronic devices.

- **Playing audio/video files:** select a source in the **Media** menu > *Category* (such as artists > album > track).
- **Moving one level up in the folder structure:** press the **BACK** button. **Or:** select and confirm **Folder up**.
- **Selecting the previous or next track/chapter<sup>1)</sup>:** press the On/Off knob on the MMI control panel briefly to the left **⏮** or right **⏭**.
- **Fast-forwarding and rewinding audio/video\* files:** press and hold the On/Off knob on the MMI control panel to the left **⏮** or right **⏭** for a longer time.
- **Pausing or resuming playback:** press the On/Off knob on the MMI control panel briefly.

### **i** Tips

- You can scroll through long lists quickly by turning the control knob quickly. The scrolling speed depends on the number of list entries.
- For safety reasons, the video image is only displayed when the vehicle is stationary. Only the sound from the video plays while driving.

## Media center

Various categories for selecting audio/video\* files are available in the media center.



Fig. 212 Example: USB stick categories



Fig. 213 Example: USB stick categories

- ▶ Press the **MEDIA** button. Press the left control button until the sources overview is displayed. Select and confirm the desired source.

### ① Active source

The active source is highlighted. The active source symbol ① may change depending on the connected device, the online media service\* or Internet radio\*. The device name may be displayed (for example: myPhone). As an example, a USB stick is shown ⇒ *fig. 212* connected to the Audi music interface\*.

Depending on the active source, you can select audio/video files\* from the following categories and add them to the playlist:

### ② Favorites

The **Favorites** category appears if at least one entry is stored in the favorites list. See ⇒ *page 237, Favorites*.

### ③ Artists

All available artists are displayed. Select and confirm an artist, an album and then a track.

### ④ Albums

All available albums are displayed. Select and confirm an album and then a track.

### ⑤ Genres

All available genres are displayed. Select and confirm a genre (such as **Pop**), an artist, an album and then a song. ▶

<sup>1)</sup> Depending on the DVD, this may not be possible during playback.

⑥ Tracks

All available tracks are displayed. Select and confirm a track.

⑦ Folders

The folder structure or track/chapter list is displayed. Select a folder, if necessary. Select and confirm a track.

⑧ Playlists

All available playlists from the source and the smart playlists are displayed. Select and confirm a playlist and then a track.

Smart playlists:

- **Last played tracks:** the last tracks played in the selected source are displayed.
- **Most played:** the most played songs in the selected source are displayed.
- **5 stars to 1 star:** tracks from the selected source are displayed according to their rating.
- **Unrated:** all files from the selected source without rating information (for example, in the ID3 tag) are displayed.

⑨ Videos\*

All available video files are displayed. Select and confirm a video file.

! Note

Applies to: vehicles with Audi connect (Infotainment) and use of the radio category with iPod/iPhone

Always follow the information found in ⇒ ! in *Wi-Fi hotspot on page 194*.

i Tips

- Only the categories supported by the medium are available. For example, CD/DVD-ROM tracks cannot be selected with categories such as **Artists**, **Albums** or **Genres**. With an iPod/iPhone (source: Audi music interface ⇒ *page 231*), the **Podcasts**, **Audio books** and **Composers** categories are also available.
- For safety reasons, the video image is only displayed when the vehicle is stationary. Only the sound from the video plays while driving.

- When synchronizing a portable device with “Cloud” services, playlists may display incorrectly in the MMI. Use the media center in the device.
- With an iPod/iPhone (media source: Audi music interface ⇒ *page 231*), the **Podcasts**, **Audio books** and **Composers** categories are also available.

i Tips

Applies to: iPod/iPhone on Audi music interface

- An Internet connection is required to use the additional **Radio** category, an online media service. Also see the chapter ⇒ *page 193, Wi-Fi hotspot*. Also read the information on the Audi music interface and the supported devices ⇒ *page 231*.
- Depending on the Internet connection and network traffic, a connection loss can occur during playback of online media services.
- The use of online media services depends on the service availability of the third party provider.
- Audi AG simply makes the access to online media services possible through the MMI and does not take any responsibility for the contents of the online media services.

Free text search

Applies to: vehicles with free text search

You can search in the active source by tracks and video files\*, for example



Fig. 214 Input field and results list for free text search

You can open the **free text search** depending on the selected source.

Requirement: the playlist ⇒ *page 237* or media center ⇒ *page 235* must be displayed.

## Opening free text search

- ▶ Keep turning the control knob to the left until the **free text search** input field ① ⇒ *fig. 214* appears. **Or:** push the control knob up.

**Using the free text search:** see ⇒ *page 157, Free text search.*

Entries that contain the entered search term are listed in the results list ⑤ ⇒ *fig. 214*. You can search for artists ② ⇒ *fig. 214*, albums ③ or tracks ④ as well as genres and videos.

### **i** Tips

- It will then search through the files in the active source.
- If you open free text search in the **Folders** category ⑦ ⇒ *page 235, fig. 213* or the **Composers, Podcasts** and **Audio books** categories, it will only search through the files in that folder.

## Playlist



Fig. 215 Example: playlist

The track, artist, album and album cover, if applicable, will appear in the playlist ⇒ *fig. 215*.

## Options menu

See ⇒ *page 237, Additional settings.*

## Favorites

*Up to 50 entries for every media source can be stored in any order in the favorites list.*

Requirement: the playlist or media center must be open.

- Select the desired entry from the playlist or media center.

- Select: right control button > **Store as favorite**. **Or:** press and hold the control knob for several seconds.

When you store a track as a favorite, the associated album will appear in the favorites list as an entry.

Requirement: at least one entry must be stored in the favorites list.

**Displaying the favorites list:** press the **MEDIA** button. Press the left control button until the sources overview ⇒ *page 234* is displayed. Select the source that contains the *categories* ⇒ *page 235* (for example, SD card). Select the **Favorites category**.

Requirement: the favorites list must be displayed.

- **Listening to a favorite:** select and confirm a *favorite from the list*.
- **Move favorite:** select a *favorite from the list* > right control button > **Move favorite**. Select and confirm the location of the selected favorite.
- **Deleting a favorite:** select a *favorite from the list* > right control button > **Delete favorite** > **Delete this favorite** or **Delete all favorites**.

## Additional settings

### Options menu

Context-specific functions and settings are available depending on the selected source.

- ▶ Press the right control button.

### Sound settings

See ⇒ *page 249*.

### Input level

Requirement: a mobile device must be connected to the AUX connection cable or to a USB adapter ⇒ *page 231, Multimedia connections.*

The volume of the mobile device is adapted to the MMI. Audi recommends adjusting the volume on the mobile device to 70% of the maximum volume output. ▶

### Bluetooth settings

See ⇒ *page 248*.

### Wi-Fi settings\*

See ⇒ *page 193, Wi-Fi hotspot*.

### Connection manager

See ⇒ *page 246*.

### Show "Now Playing" screen

With the function switched on  and a playlist open, various information about the current track (such as artist, album and album cover\*) as well as the playing time and the remaining playing time are displayed.

### Jukebox memory capacity\*

Information on the Jukebox memory capacity and the number of stored tracks in the Jukebox is displayed.

### Rewind/Fast forward

Turn the control knob to the left or to the right.  
**Or:** move your finger across the MMI touch control pad\* from left to right.

### Shuffle<sup>1)</sup>

With the function switched on , all files in the playlist are played and shown in random order.

### Repeat track<sup>1)</sup>

When the function is switched on , the current track repeats.

### Repeat\*

Requirement: an iPod/iPhone\* must be selected as the media source in the Audi music interface ⇒ *page 234, Accessing media*.

- **Track:** the current track will be repeated.
- **Folder:** the tracks in the current folder are repeated continuously in a loop.
- **Off:** the function is switched off.

### Back to 'Playback'

The options menu is closed. The track currently playing appears in the playlist.

### Play similar music\*

The track currently playing is quickly analyzed (such as artists, genres, mood, beat) and a smart playlist with similar tracks is shown.

### Play more...

A smart playlist is shown based on the track currently playing. You can select between a playlist with more tracks **by this artist, from this album or of this genre**.

### Copy to jukebox\*

See ⇒ *page 227, Adding files to the Jukebox*.

### Set as ringtone\*<sup>2)</sup>

Requirement: a cell phone must be connected to the MMI. The track currently playing must be in the Jukebox\* ⇒ *page 227*.

The selected track will be used as the ringtone for incoming calls.

### Gracenote online database\*

Requirement: the MMI must be connected to the Internet.

Depending on availability, various information will load about the track currently playing when this function is switched on .

### Favorites

See ⇒ *page 237*.

### Additional options

Requirement: the vehicle must be stationary and a video file\* or a DVD\* must be playing.

### Parental control\*

Playback of video DVDs can be restricted using parental control. ►

---

1) The function automatically switches off when the source is changed.

2) This function is not available for all cell phones.

Enter the password for parental control. Password set at the factory: **1234**. You have the following options:

- **Protection level:** select and confirm the protection level (for example, Level 5). Eight different protection levels can be set for parental control. If you set the parental control level at Level 5, all DVDs from level 1-5 can be played. Video DVDs with a higher level will not play. Select **Unrestricted** to remove all of the restrictions.
- **Change password:** edit the current password.

### Switch to full screen

The video image is displayed. Turn the control knob to display the playlist. **Or:** press the **BACK** button.

### Replay video<sup>1)</sup>

When this function is switched on , the current video will replay.

### Show DVD menu

The DVD main menu opens in the Infotainment system display.

- **Selecting a menu item:** select and confirm a menu item. **Or:** move your finger on the MMI touch control pad\* and press the control knob.

### Audio track<sup>2)</sup>

You can manually set the audio track (language and audio format). The language and audio format options depend on the video DVD.

### Subtitles<sup>2)</sup>

You can set subtitles for playback manually. The languages available depend on the DVD.

### Aspect

Audi recommends the **Automatic** setting for the picture format. You can set the picture format depending on the active file or source (for example video file\*, DVD\*).

Picture format	Description
<b>Automatic</b>	The MMI detects the picture format of the source and displays the image in the optimum ratio. Black bars may appear on the sides of the display, depending on the source format and the Infotainment system display that is installed.
<b>Zoom</b>	The image is enlarged to fill the entire Infotainment system display. Switch the function off if the image is distorted.
<b>Cinema-scope</b>	Use this setting for films in cinema format 21:9. Black bars are shown in the upper and lower edges of the Infotainment system display.
<b>Original</b>	The image is displayed in the ratio of the source format. Select this option if the image is distorted or a section of the image is cut off when <b>Auto</b> is selected.
<b>4:3</b>	The image is fixed in the 4:3 picture format. Black bars are shown on the sides of the Infotainment system display.
<b>16:9</b>	The image is fixed in the 16:9 picture format. Black bars are shown in the upper and lower edges of the Infotainment system display.

### Tips

- Not all video DVDs have parental control.
- The protection levels for the **Parental control** are based on the US standards from the Motion Picture Association of America (MPAA). Note that the age levels for video DVDs in European countries may differ.
- Password entry for **Parental control** will be locked for approximately one minute if you enter the incorrect password three times in

<sup>1)</sup> The function automatically switches off when the source is changed.

<sup>2)</sup> Depending on the DVD, this may not be possible during playback.

a row. The password can only be reset by an authorized Audi dealer.

## Supported media and file formats

### Overview

The Jukebox\*, SD card reader and the USB storage device\* connection support the following audio/video file properties:

	Audio files				Video files*		
<b>Supported media</b>	<p><b>SD/SDHC/SDXC/MMC memory cards:</b> with a capacity of up to 128 GB</p> <p><b>DVD drive:</b> audio CDs (up to 80 min) with CD text (artist, album, song)*, CD-ROMs with a capacity of up to 700 MB; DVD±R/RW; DVD video; DVD audio with audio tracks that are compatible with a DVD video player;</p> <p><b>Audi music interface:</b> mobile devices (such as an iPod ⇒ <i>page 231</i>, MTP player, USB storage device in “USB Device Subclass 1 and 6” that conforms to USB 2.0: USB sticks, USB MP3 players (Plug-and-Play-capable), external USB flash drives and hard drives</p>						
<b>File system</b>	<p><b>Memory cards:</b> exFAT, FAT, FAT32, NTFS</p> <p><b>USB storage device:</b> FAT, FAT32, NTFS</p> <p><b>USB storage device partitions (primary/logical*):</b> 2 per USB-connection</p> <p><b>CD/DVD file system:</b> ISO9660, Joliet, UDF</p>						
<b>Metadata</b>	<p><b>Album cover:</b> GIF, JPG, PNG with max. 800x800 px. The album cover from the medium or from Gracenote* is displayed, depending on availability.</p>						
<b>Format</b>	MPEG 1/2 Layer 3	Windows Media Audio 9 and 10	MPEG 2/4	FLAC	MPEG 1/2	MPEG4 AVC (H.264)	Windows Media Video 9
<b>File extension</b>	.mp3	.wma	.m4a; .m4b; .aac	.flac	.mpg; .mpeg	.mp4; .m4v; .mov; .avi	.wmv; .asf
<b>Playlists</b>	.M3U; .PLS; .WPL; .M3U8; .ASX						
<b>Characteristics</b>	up to maximum 320 kbit/s and 48 kHz sampling frequencies		48 kHz sampling frequency		up to maximum 2,000 kbit/s and 720x576 px. at maximum 25 fps		
<b>Number of files</b>	<p><b>DVD drive*:</b> max. 1,000 files per medium</p> <p><b>Jukebox*:</b> approximately 10 GB memory capacity; max. 3,000 files can be imported</p> <p><b>USB storage device and memory cards:</b> max. 10,000 files per medium; max. 1,000 files per playlist/directory</p>						

### Tips

– The media drives do not support the Windows Media Audio 9 Voice format.

– For compressing MP3 files, Audi recommends a bit rate of at least 160 kbit/s. The display showing the remaining play time

may differ for audio files with variable bit rate.

- Special characters (such as those in ID3 tag information) display differently depending on the system language and cannot always be guaranteed.

– The manufacturer of the storage device can provide information about its “USB Device Subclass”.

- Some MTP player functions are not supported, such as rating music tracks and video playback.

## CD drive

Applies to: vehicles with a CD drive

The following audio file properties are supported by the CD drive:

	Audio files			
<b>Supported media</b>	Audio CDs (up to 80 min) with CD text (artist, album, track)*, CD-ROMs with a capacity of up to 700 MB			
<b>File system</b>	CD file system: ISO9660, Joliet, UDF			
<b>Metadata</b>	Album cover: GIF, JPG, PNG with max. 800x800 px. The album cover from the medium may be displayed, depending on availability.			
<b>Format</b>	MPEG 1/2 Layer 3	Windows Media Audio 9 and 10	MPEG 2/4	FLAC
<b>File extension</b>	.mp3	.wma	.m4a; .m4b; .aac	.flac
<b>Playlists</b>	.M3U; .PLS; .WPL; .M3U8; .ASX			
<b>Characteristics</b>	up to maximum 320 kbit/s and 48 kHz sampling frequencies			48 kHz sampling frequency
<b>Number of files</b>	Maximum 1,000 files per medium			

### Tips

- For compressing MP3 files, Audi recommends a bit rate of at least 160 kbit/s. The display showing the remaining play time may differ for audio files with variable bit rate.

- Special characters (such as those in ID3 tag information) display differently depending on the system language and cannot always be guaranteed.

## Troubleshooting

Problem	Solution
<b>Audi music interface/Bluetooth audio player*</b> : mobile device is not supported.	Read the instructions in the chapter ⇒ <i>page 231, Multimedia connections</i> /⇒ <i>page 228, Bluetooth audio player</i> . You can learn about supported mobile devices in the Audi database for mobile devices at <a href="http://www.audiusa.com/bluetooth">www.audiusa.com/bluetooth</a> .
<b>Audi music interface</b> : the volume is too high/too low when starting playback through the AUX input.	Adjust the volume of the mobile device to approximately 70% of the maximum output ⇒ <i>page 237, Input level</i> .

Problem	Solution
<b>Audi music interface:</b> the portable device is not recognized as a source.	For many cell phones or mobile devices, playback is not possible when the battery level is too low (less than 5% of its capacity). The mobile device will only be recognized as a source in the MMI after connecting if the battery charge is sufficient.
<b>Audi music interface:</b> malfunctions during audio playback through an iPod/iPhone.	The <b>Bluetooth audio player</b> function is switched on. Switch this function off ⇒ <i>page 248</i> when you are not using the <b>Bluetooth audio player</b> .
<b>Audi music interface:</b> contents that are changed on a mobile device connected to the Audi music interface <sup>a)</sup> are not displayed in the media center.	Reset the <b>Media settings</b> to the factory default settings ⇒ <i>page 246</i> .
<b>AUX input:</b> there is static when connecting and disconnecting the AUX connection cable.	When connecting and disconnecting, the <b>External audio player</b> source is already selected. Before connecting or disconnecting the mobile device, either mute the device (see ⇒ <i>page 249</i> ) or switch to a different audio source (for example ⇒ <i>page 220, Opening the radio</i> ).
<b>Bluetooth audio player*/Wi-Fi audio player*:</b> audio playback interference.	Only <i>one</i> interface should be actively used at a time to ensure problem-free playback.
<b>Jukebox*:</b> tracks on the imported playlist are grayed out.	When importing playlists, all of the files themselves must be imported.
<b>Jukebox*:</b> imported tracks cannot be played or found.	If you cannot find imported tracks in the media center, they may not be supported. Only copy supported files ⇒ <i>page 240</i> to the Jukebox.
<b>Online media*:</b> connection failed between the MMI and the <b>Audi MMI connect</b> app.	To establish a connection to the MMI, the MMI connection switch must be switched on in the <b>Audi MMI connect</b> app status screen.
<b>Bluetooth audio player*:</b> interference with track display and audio playback.	Playback interference can occur when using the <b>Bluetooth audio player</b> if a music player app from a third party provider is open. Audi recommends using the integrated media player on your Bluetooth device (such as a smartphone).
<b>Wi-Fi hotspot*:</b> your Wi-Fi device is disconnected from the Wi-Fi hotspot.	Make sure the network optimization functions are switched off in the Wi-Fi settings or in the network settings for your Wi-Fi device. For additional information refer to the user guide for your Wi-Fi device.
<b>Audi music interface:</b> audio playback through the connected mobile device is not possible.	Make sure the USB mode <i>MTP</i> is selected in the settings on your mobile device.

<sup>a)</sup> Applies only to MTP devices. Does not apply to Apple devices and USB mass storage devices.

# Audi smartphone interface

## Setup

Applies to: vehicles with Audi smartphone interface

You can connect your smartphone to the MMI using the Audi smartphone interface. Certain content on your smartphone is adapted to the Infotainment system display while driving and can be operated through the MMI control panel.

### Requirement

The vehicle must be stationary and the ignition must be switched on.

iPhone generation 5 or higher with Lightning connector and iOS 7.1.2 operating system or higher. **Or:**

Smartphone with Android Auto app and Android 5.0 Lollipop operating system or higher.

- ▶ Connect your smartphone to the Audi music interface ⇒ *page 232* using a USB adapter ⇒ *page 231, fig. 208*.
- ▶ Select and confirm **Activate Apple CarPlay** or **Activate Android Auto now**.
- ▶ Follow the system instructions.
- ▶ Pay attention to any additional system prompts on your smartphone if applicable.

If you chose not to use Apple CarPlay or Android Auto when connecting your smartphone for the first time, you can start the Audi smartphone interface later on using the **Connection manager**.

- ▶ Select: **MENU** button > **Audi smartphone interface** > **Change to connection manager**.
- ▶ Connect your smartphone to the Audi music interface using a USB adapter ⇒ *page 231, fig. 208*.
- ▶ Select and confirm **Audi smartphone** in the **Connection manager** ⇒ *page 246*. You can select your smartphone in the list of devices that are already paired ⇒ *page 247*.
- ▶ Follow the system instructions.

### ! Note

Always follow the information found in ⇒ ! in *Wi-Fi hotspot on page 194*.

### i Tips

- The functions that can be used depend on the following factors, among others:
  - the brand of your smartphone
  - the version of the operating system in your smartphone
  - the software version of the app used
  - the USB adapter cable and correct connection
  - your cell phone service provider
  - the customized settings on your smartphone
- One of the factors above or a combination of any of them could cause your smartphone to be incompatible with the Audi smartphone interface. Compatibility cannot be guaranteed for all types of smartphones. For more information and assistance, refer to the user guide and the manufacturer of your smartphone.
- If the connected smartphone has voice control, you can operate your smartphone using the external voice recognition system ⇒ *page 172*.
- The menu language shown in the MMI is based on the settings in your smartphone.
- The time displayed in the MMI is based on the settings in your smartphone.
- Several MMI functions are not available when Apple CarPlay or Android Auto is active.
- You cannot connect any mobile devices via Bluetooth when an Apple CarPlay connection is active.

## Operating

Applies to: vehicles with Audi smartphone interface

### Opening a menu

**Apple CarPlay:** you can go back to the Apple CarPlay main menu regardless of the selected menu item by pressing and holding the **BACK** button.

**Android Auto:** to go back to the Android Auto menu bar, push the control knob down. ▶

### Opening a menu item

Select and confirm a menu item using the MMI control panel.

## Troubleshooting

Applies to: vehicles with Audi smartphone interface

Problem	Solution
<b>Audi smartphone interface</b> cannot be opened.	Check the battery charge level on your smartphone. Check the USB cable and use a different one if necessary. Check if Android Auto or Apple CarPlay is available in your country.
	<b>Android Auto:</b> check if the Android Auto app is installed on your smartphone.
<b>Connecting</b> the smartphone to the MMI failed.	Make sure that you are using the correct USB adapter and check if the USB adapter is connected correctly to your smartphone and the Audi music interface ⇒ <i>page 231</i> .
	<b>Apple CarPlay:</b> check if Apple CarPlay is activated on your smartphone.
	<b>Android Auto:</b> check in the Android Auto app if Android Auto permits new vehicles.
The smartphone is not automatically detected.	Make sure that you are using the correct USB adapter and check if the USB adapter is connected correctly to your smartphone and the Audi music interface ⇒ <i>page 231</i> . Check if the requirements needed to connect a smartphone have been met.

## System settings

### Setting the date and time

You can set the clock time manually or using the GPS\*.

- ▶ Select: **MENU** button > **Settings** > left control button > **MMI settings** > **Date & time**.
- ▶ Or: select: **MENU** button > **Vehicle** > left control button > **Vehicle settings** > **Date & time**.

#### Automatic setting

When this function is switched on , the time and date are automatically set.

#### Time

Requirement: the **Automatic setting** must be switched off.

Press the control knob. You can set the **Time** manually by turning and pressing the control knob.

#### Date

Requirement: the **Automatic setting** must be switched off.

Press the control knob. You can set the **Date** manually by turning and pressing the control knob.

#### Time zone

When selecting the appropriate time zone, a sampling of countries in this zone will be listed.

#### Automatic time zone\*

When this function is switched on , the time will automatically adjust to the corresponding time zone.

#### Automatic daylight saving time\*

When this function is switched on , the time will automatically switch to daylight saving time.

#### Time format

If you select **24h**, the clock will display, for example, **13:00**. If you select **AM/PM**, the clock will display, for example, **1:00 PM**.

#### Date format

If you select **DD.MM.YYYY**, the date display will show, for example, **31.08.2018**. If you select **MM/DD/YYYY**, the date display will show, for example, **08/31/2018**. If you select **YYYY-MM-DD**, the date display will show, for example, **2018-08-31**.

### MMI settings

- ▶ Select: **MENU** button > **Settings** > left control button > **MMI settings**.

#### Language

You can change the display language as well as the language for the voice guidance\* and voice recognition system\*.

The number of languages available depends on the market.

#### Measurement units

The following measurement units can be set depending on availability: **Speed, Distance, Temperature, Fuel consumption, Volume, Pressure**.

#### Tool tips

When this function is switched on , your MMI shows you tips for input. The frequency of how often it displays decreases with time.

#### Speech dialog system

Applies to: vehicles with voice recognition system

Depending on vehicle equipment, the following functions may be available:

**Command display:** when this function is switched on , the MMI will show you the possible commands for voice input in the respective menu.

**Short dialog:** when this function is switched on , a shorter form of the prompts is used.

**Command during voice output\*:** this function is switched on at the factory. When this function is switched on , you can say new commands during announcements. You do not need to wait for the signal tone (beep) during an announcement. When the function is switched off , you need to ►

wait for the signal tone (beep) to say a new command.

**Volume:** you can adjust the volume of the prompts by turning the control knob.

**Individual speech training** (only when the vehicle is stationary): you can adapt the voice recognition system to your voice or pronunciation in order to improve the system's ability to recognize your speech. Individual speech training is comprised of 20 speech entries that consist of commands and sequences of numbers. You can delete the programmed voice training with the **Reset individual speech training** function.

### Display brightness

You can adjust the brightness of the Infotainment system display by turning the control knob.

### Factory settings

Depending on the vehicle equipment, the following functions can be reset to factory settings:

- **Sound settings**
- **Radio**
- **Media settings**
- **Jukebox\***
- **Directory**
- **Telephone**
- **Bluetooth and Wi-Fi\***
- **Navigation settings\***
- **Navigation and online memory\***
- **Speech dialog system\***
- **Shortcut keys**
- **Message settings\***
- **Apps\***
- **Tool tips**
- **Audi connect\***
- **Audi smartphone interface\***

You can select the desired functions individually or all at once with the option **Select all entries**. Select and confirm **Restore factory settings**.

#### **Tips**

Make sure that not only the settings were deleted but also the stored data, if applicable.

## Connection manager

### Introduction

*The connection manager gives you an overview of your connected devices and their network status.*



Fig. 216 Connection manager

- ▶ Select: **MENU** button > **Settings** > left control button > **MMI settings** > **Connection manager**.
- ▶ Select and confirm a menu item.

If a mobile device was already connected and you select and confirm the corresponding menu item, the device name and connection mode are displayed under the menu item ⇒ *fig. 216*.

You can individually **connect** () or **disconnect** () a paired device.

Requirement:

- The vehicle must be stationary and the ignition must be switched on.
- The Bluetooth settings will open on your mobile device during the connection setup.
- The Bluetooth function and visibility of the MMI ⇒ *page 248* and mobile device must be switched on.
- The mobile device to be connected must not be connected to any other Bluetooth device.

### Primary phone

Applies to: vehicles with telephone

- **Connect new device:** search for and connect a cell phone.
- **List of devices already paired:** select your cell phone from the list of all the devices that are already paired.

## Secondary phone

Applies to: vehicles with telephone

- **Connect new device:** search for and connect a cell phone.
- **List of devices already paired:** select your cell phone from the list of all the devices that are already paired.

## Data connection

Applies to vehicles with Audi connect (Infotainment)

- The data connection is made using the embedded SIM card <sup>1)</sup> ⇒ *page 187*. You do not need to adjust any additional settings.

### ! Note

Always follow the information found in ⇒ ! in *Wi-Fi hotspot on page 194*.

## MMI connect app

Applies to vehicles with Audi connect (Infotainment)

Requirement: the **Audi MMI connect** app must be installed and open on your mobile device.

- **Connect new device:** search for and connect a mobile device (such as a smartphone).
- **List of devices already paired:** select your mobile device from the list of all the devices that are already paired.

## Audio player

Applies to vehicles with Bluetooth or Wi-Fi audio player

### Bluetooth player\*

Requirement: the Bluetooth function and visibility must be switched on in the MMI ⇒ *page 248* and on the Bluetooth audio player.

- **Connect new device:** press the control knob. Select **Bluetooth audio player**. Search for and connect a mobile device.
- **List of devices already paired:** select a Bluetooth device from the list of all the devices that are already paired.

### Wi-Fi audio player\*

Requirement: the Wi-Fi hotspot\* on the MMI ⇒ *page 193* and on your Wi-Fi audio player must be switched on.

- **Connect new device:** press the control knob. Search for and connect a Wi-Fi capable device.
- **Disconnect Wi-Fi audio player:** deactivate the Wi-Fi on your Wi-Fi capable device. The device will be automatically removed from the list.

### ! Note

Always follow the information found in ⇒ ! in *Wi-Fi hotspot on page 194*.

## Directory

Applies to: vehicles with telephone

*Display contacts from a cell phone (or an additional cell phone).*

Requirement: no cell phones can be connected to the MMI using the **Handsfree** profile.

- **Connect new device:** search for and connect a new cell phone.
- **List of devices already paired:** select your cell phone from the list of all the cell phones that are already paired.

## Audi smartphone

Applies to: vehicles with Audi smartphone interface

- Connect your cell phone to the Audi music interface ⇒ *page 232* using a USB adapter ⇒ *page 231, fig. 208*.
- Select your cell phone from the list of cell phones that have already been connected.

## Additional options

Depending on the selected function, you can use the right control button to access the available additional options in the connection manager. ►

<sup>1)</sup> SIM card installed in the vehicle at the factory.

### Delete Bluetooth device\*

The selected cell phone/mobile device is disconnected from the MMI and is removed from the list of all devices that are already paired.

### Show Bluetooth profiles\*

You can **Connect** or **Disconnect** the **Handsfree**, **Messages\***, **Directory/contacts** and **Bluetooth audio player** profiles separately.

### Bluetooth settings\*

- **Bluetooth**: select and confirm a setting for the Bluetooth connection visibility. Select **Visible** for the MMI to be visible to other devices. Select **Invisible** for the MMI to not be visible to other devices. However, it is still possible to establish a Bluetooth connection with paired devices when the visibility is switched off. Select **Off** to turn visibility off. Then a Bluetooth connection is not possible.
- **Bluetooth audio player**: when this function is switched on , the Bluetooth audio player is available as a source in the **Media** menu.
- **Bluetooth name**: the MMI Bluetooth name (for example "AUDI MMI") is displayed and can be changed.

### Online settings\*

- **Data usage counter**: the amount of data packets that are sent and received through the MMI is displayed. You can reset the data usage information to zero using the **Reset data counter** option.
- **Network status**: the mobile network provider for data service as well as the network status are displayed.

### Wi-Fi settings\*

See ⇒ *page 193, Wi-Fi hotspot.*

### Storing as a default telephone

Applies to: vehicles with telephone

Requirement: a cell phone must be connected to the MMI ⇒ *page 174.*

As soon as the cell phone is in range and the Bluetooth function on the cell phone and in the MMI is switched on, this cell phone is given priority over the other Bluetooth devices and is con-

nected directly to the MMI. The connected cell phone is displayed first in the device list.

### Network settings\*

- **Login**: you can choose an **automatic** login to your cell phone service provider's network, or you can choose a **manual** login from the list of available networks.
- **Network selection**: available networks in the present location can be selected under network selection. This function is only available for the **Manual** login setting.

### Apple CarPlay sound settings/Android Auto sound settings

Applies to: vehicles with Audi smartphone interface

See ⇒ *page 249.*

### About Apple CarPlay/About Android Auto

Applies to: vehicles with Audi smartphone interface

Here you will find legal information regarding the use of Apple CarPlay or Android Auto and information about device-specific data exchange.

### Delete Apple CarPlay device/Delete Android Auto device

Applies to: vehicles with Audi smartphone interface

Requirement: your cell phone must not be connected to the Audi music interface with a USB adapter.

Select: **Audi smartphone** > a device from the list > right control button.

To remove your cell phone from the list, select and confirm **Delete Apple CarPlay device** or **Delete Android Auto device**.

## System update

▶ Select: **MENU** button > **Settings** > left control button > **System maintenance**.

- **System update**: slide the storage device with the update data into the appropriate drive ⇒ *page 226*. Select and confirm the drive > **Start update**. The length of the process depends on the size of the update.
- **Reset driver installation**: the selected media driver package is reset to the settings at the time of delivery. ▶

- **Version information:** information on the MMI software version and the navigation database\* software version is displayed. The **Software information** function also provides information on the software contained in the MMI and the licensing agreement.

## Sound settings

The sound distribution and volume of the MMI can be adjusted individually. The settings depend on vehicle equipment.



Fig. 217 Adjusting the balance/fader

- ▶ Select: **MENU** button > **Sound** > left control button > **Entertainment**.

### Treble / Bass

You can adjust the **Treble** and **Bass** settings by turning the control knob. The changed settings only apply for the audio source that is active at the time. This allows you to adjust the sound settings for each audio source separately.

### Balance/fader (Sound focus)

- **Adjusting the sound distribution to the left or right:** press the control knob. Turn the control knob to the left or right to the desired position.
- **Adjusting the sound distribution to the front or rear:** press the control knob again. Turn the control knob to the left or right to the desired position.
- **Adjusting the sound distribution using the MMI touch\*:** move your finger on the MMI touch control panel in the desired direction.

### Sound effects

Select and confirm a **Focus** setting:

- **All:** all speakers in the vehicle are active (symmetrical sound distribution).

- **Front:** only the speakers in the front of the vehicle are active.
- **Rear\*:** only the speakers in the rear of the vehicle are active.

Select and confirm a **3D effect\*** setting (surround sound):

- **Off:** the 3D effect is switched off.
- **Low:** the 3D effect is optimized, for example for audio books.
- **Medium:** the 3D effect is optimized for all sources.
- **High:** the 3D effect is at the maximum.

### Subwoofer\*

Turn the control knob to adjust the subwoofer.

### Speed dependent volume control

Turn the control knob to adjust the playback volume to the noise inside the vehicle.

## Volume settings

### Adjusting the volume

The volume of an audio source or a system message (for example, from the voice recognition system\*) can be adjusted directly while the sound is playing using the On/Off knob.

- **Increasing or decreasing the volume:** turn the On/Off knob ① ⇒ page 148, fig. 149 to the right or left.
- **Muting or pausing:** press the On/Off knob briefly. **Or:** turn the On/Off knob to the left until the symbol ⑫ ⇒ page 158 appears. An active audio/video source is stopped.
- **Unmuting or resuming:** press the On/Off knob briefly. **Or:** turn the On/Off knob to the right.

### ⚠ WARNING

To reduce the risk of an accident, adjust the volume of the audio system so that audible signals from outside the vehicle, such as police and fire sirens, can be heard easily at all times.

### Tips

Volumes that are too high or too low are automatically adjusted to a set level when the MMI is switched on.

### Adjusting the system volume

- ▶ Select: **MENU** button > **Sound** > left control button.

### Telephone

Applies to: vehicles with telephone

**Mute telephone:** messages and ringtones are set to mute.

**Ringtone:** see ⇒ page 185, **Ringtone and volume settings**.

**Ringtone volume:** you can adjust the volume of the selected ringtone by turning the control knob.

**Message volume:** you can adjust the volume of the notification for an incoming text message by turning the control knob.

**Microphone input level:** you can adjust the call volume during a phone call by turning the control knob.

### Navigation

Applies to: vehicles with navigation system

**Voice guidance:** see ⇒ page 212.

**Voice guidance during phone call:** see ⇒ page 212.

**Voice guidance volume:** you can adjust the voice guidance volume by turning the control knob. **Or:** you can adjust the voice guidance volume during active route guidance by turning the On/Off knob.

**Entertainment fader:** the volume of audio playback can be temporarily lowered when the parking system or voice guidance is active.

### Voice recognition system

Applies to: vehicles with voice recognition system

**Command display:** see ⇒ page 245.

**Short dialog:** see ⇒ page 245.

**Volume:** see ⇒ page 245.

**Individual speech training:** see ⇒ page 245.

### Parking aid\*

You can adjust the volume of the signal tone by turning the control knob.

- **Adjusting the Front volume:** select and confirm **High, Medium** or **Low**.
- **Adjusting the Rear volume:** select and confirm **High, Medium** or **Low**.

### MMI touch\*

Turn the control knob to adjust the volume of the spoken prompts from the MMI touch\*.

## Restarting the MMI

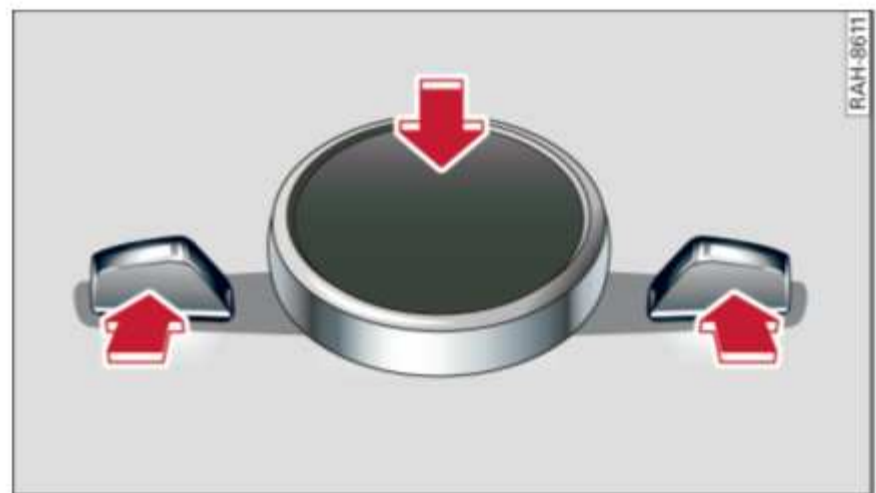

Fig. 218 Button combination to restart the system

- ▶ Briefly press the control knob and both buttons *at the same time* to immediately open the menu upward ⇒ fig. 218.

## Software license information

### Information on MMI software and licensing agreements

- Select: **MENU** button > **Settings** > left control button > **System maintenance** > **Version information**.
- **Or:** online at [www.audiusa.com/softwareinfo](http://www.audiusa.com/softwareinfo).

### Information on head-up display software and licensing agreements

- Requirement: the vehicle must be stationary. ▶

- Press and hold the head-up display button  for more than five seconds after switching on the ignition.
- Press the control knob to close the information.  
**Or:** start driving.

### **Information on instrument cluster software and licensing agreements**

Press the reset button  <sup>1)</sup> twice within five seconds of switching the ignition on.

---

<sup>1)</sup> Not available in all vehicles.

## Driving safety

### Basics

#### Safe driving habits

*Please remember - safety first!*

The individual safety features of your vehicle can work together as a system to help protect you and your passengers in a wide range of accidents. These features cannot work as a system if they are not always correctly adjusted and correctly used.

This chapter contains important information, tips, instructions and warnings that you need to read and observe for your own safety, the safety of your passengers and others. We have summarized here what you need to know about safety belts, airbags, child restraints as well as child safety. Your safety is for us *priority number 1*. Always observe the information and warnings in this section - for your own safety as well as that of your passengers.

The information in this section applies to all model versions of your vehicle. Some of the features described in this sections may be standard equipment on some models, or may be optional equipment on others. If you are not sure, ask your authorized Audi dealer.

#### WARNING

- Always make sure that you follow the instructions and heed the WARNINGS in this manual. It is in your interest and in the interest of your passengers.
- Always keep all of the Owner's Literature manuals in your Audi when you lend or sell your vehicle so that this important information will always be available to the driver and passengers.
- Always keep the Owner's Literature handy so that you can find it easily if you have questions.

#### Important things to do before driving

*Safety is everybody's job! Vehicle and occupant safety always depends on the informed and careful driver.*

For your safety and the safety of your passengers, **before driving always:**

- ▶ Make sure that all lights and signals are operating correctly.
- ▶ Make sure that the tire pressure is correct.
- ▶ Make sure that all windows are clean and afford good visibility to the outside.
- ▶ Secure all luggage and other items carefully ⇒ *page 257*.
- ▶ Make sure that nothing can interfere with the pedals.
- ▶ Adjust front seat, head restraint and mirrors correctly for your height.
- ▶ Instruct passengers to adjust the head restraints according to their height.
- ▶ Make sure to use the right child restraint correctly to protect children ⇒ *page 291, Child safety*.
- ▶ Sit properly in your seat and make sure that your passengers do the same ⇒ *page 56, Front seats*.
- ▶ Fasten your safety belt and wear it properly. Also instruct your passengers to fasten their safety belts properly ⇒ *page 261*.

#### What impairs driving safety?

*Safe driving is directly related to the condition of the vehicle, the driver as well as the driver's ability to concentrate on the road without being distracted.*

The driver is responsible for the safety of the vehicle and all of its occupants. If your ability to drive is impaired, safety risks for everybody in the vehicle increase and you also become a hazard to everyone else on the road ⇒ . Therefore:

- ▶ Do not let yourself be distracted by passengers or by using a cellular telephone.
- ▶ NEVER drive when your driving ability is impaired (by medications, alcohol, drugs, etc.).
- ▶ Observe all traffic laws, rules of the road and speed limits and plain common sense.

- ▶ ALWAYS adjust your speed to road, traffic and weather conditions.
- ▶ Take frequent breaks on long trips. Do not drive for more than two hours at a stretch.
- ▶ Do NOT drive when you are tired, under pressure or when you are stressed.

### WARNING

Impaired driving safety increases the risk of serious personal injury and death whenever a vehicle is being used.

## Correct passenger seating positions

### Proper seating position for the driver

The proper driver seating position is important for safe, relaxed driving.

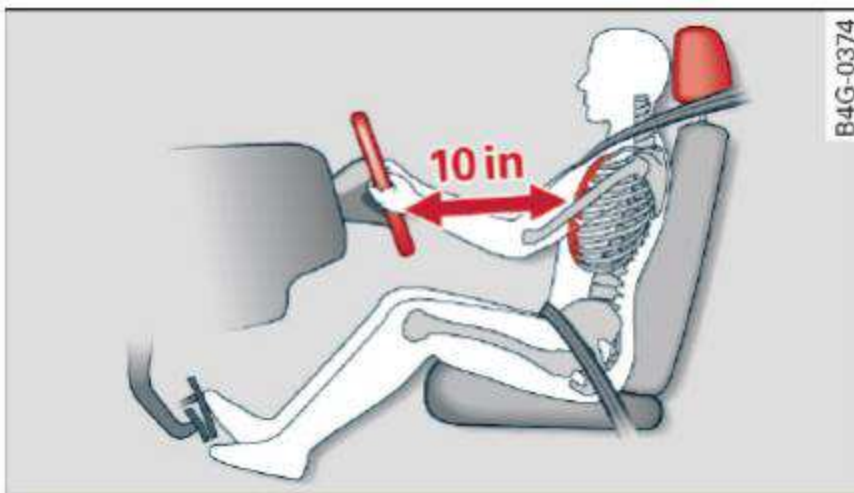



Fig. 219 Correct seating position

For your own safety and to reduce the risk of injury in the event of an accident, we recommend that you adjust the driver's seat to the following position:

- ▶ Adjust the driver's seat so that you can easily push the pedals all the way to the floor while keeping your knee(s) slightly bent ⇒ .
- ▶ Adjust the angle of the seatback so that it is in an upright position so that your back comes in full contact with it when you drive.
- ▶ Adjust the steering wheel so that there is a distance of at least 10 inches (25 cm) between the steering wheel and your breast bone ⇒ *fig. 219*. If not possible, see your authorized Audi dealer about adaptive equipment.

- ▶ Adjust the steering wheel so that the steering wheel and airbag cover points at your chest and not at your face.
- ▶ Grasp the top of the steering wheel with your elbow(s) slightly bent.
- ▶ Adjust the head restraint so the upper edge is as even as possible with the top of your head. If that is not possible, try to adjust the head restraint so that it is as close to this position as possible.
- ▶ Fasten and wear safety belts correctly ⇒ *page 264*.
- ▶ Always keep both feet in the footwell so that you are in control of the vehicle at all times.

For detailed information on how to adjust the driver's seat, see ⇒ *page 56*.

### WARNING

Drivers who are unbelted, out of position or too close to the airbag can be seriously injured by an airbag as it unfolds. To help reduce the risk of serious personal injury:

- Always adjust the driver's seat and the steering wheel so that there are at least 10 inches (25 cm) between your breastbone and the steering wheel.
- Always hold the steering wheel on the outside of the steering wheel rim with your hands at the 9 o'clock and 3 o'clock positions to help reduce the risk of personal injury if the driver's airbag inflates.
- Never hold the steering wheel at the 12 o'clock position or with your hands at other positions inside the steering wheel rim or on the steering wheel hub. Holding the steering wheel the wrong way can cause serious injuries to the hands, arms and head if the driver's airbag deploys.
- Pointing the steering wheel toward your face decreases the ability of the supplemental driver's airbag to protect you in a collision.
- Always sit in an upright position and never lean against or place any part of your body too close to the area where the airbags are located.

- Before driving, always adjust the front seats and head restraints properly and make sure that all passengers are properly restrained.
- Never adjust the seats while the vehicle is moving. Your seat may move unexpectedly and you could lose control of the vehicle.
- Never drive with the backrest reclined or tilted far back! The farther the backrests are tilted back, the greater the risk of injury due to incorrect positioning of the safety belt and improper seating position.
- Children must always ride in child safety seats ⇒ *page 291*. Special precautions apply when installing a child safety seat on the front passenger seat ⇒ *page 269*.

### Proper seating position for the front passenger

*The proper front passenger seating position is important for safe, relaxed driving.*

For your own safety and to reduce the risk of injury in the event of an accident, we recommend that you adjust the seat for the front passenger to the following position:

- ▶ Adjust the angle of the seatback so that it is in an upright position and your back comes in full contact with it whenever the vehicle is moving.
- ▶ Adjust the head restraint so the upper edge is as even as possible with the top of your head. If that is not possible, try to adjust the head restraint so that it is as close to this position as possible ⇒ *page 58*.
- ▶ Keep both feet flat on the floor in front of the front passenger seat.
- ▶ Fasten and wear safety belts correctly ⇒ *page 264*.

For detailed information on how to adjust the front passenger's seat, see ⇒ *page 56*.

### WARNING

Front seat passengers who are unbelted, out of position or too close to the airbag can be seriously injured or killed by the airbag as it unfolds. To help reduce the risk of serious personal injury:

- Passengers must always sit in an upright position and never lean against or place any part of their body too close to the area where the airbags are located.
- Passengers who are unbelted, out of position or too close to the airbag can be seriously injured by an airbag as it unfolds with great force in the blink of an eye.
- Always make sure that there are at least 10 inches (25 cm) between the front passenger's breastbone and the instrument panel.
- Each passenger must always sit on a seat of their own and properly fasten and wear the safety belt belonging to that seat.
- Before driving, always adjust the front passenger seat and head restraint properly.
- Always keep your feet on the floor in front of the seat. Never rest them on the seat, instrument panel, out of the window, etc. The airbag system and safety belt will not be able to protect you properly and can even increase the risk of injury in a crash.
- Never drive with the backrest reclined or tilted far back! The farther the backrests are tilted back, the greater the risk of injury due to incorrect positioning of the safety belt and improper seating position.
- Children must always ride in child safety seats ⇒ *page 291*. Special precautions apply when installing a child safety seat on the front passenger seat ⇒ *page 269*.

### Proper seating positions for passengers in rear seats

*Rear seat passengers must sit upright with both feet on the floor consistent with their physical size and be properly restrained whenever the vehicle is in use.*

To reduce the risk of injury caused by an incorrect seating position in the event of a sudden braking maneuver or an accident, your passengers on the rear bench seat must always observe the following:

- ▶ If there are passengers on the outer rear seats, adjust the head restraints so the upper edge is ▶

as even as possible with the top of your head. If that is not possible, try to adjust the head restraint so that it is as close to this position as possible. If there is a passenger in the center rear seat, slide the head restraint upward ⇒ *page 58*.

- ▶ Make sure that the seatback is securely latched in the upright position ⇒ *page 63*.
- ▶ Keep both feet flat in the footwell in front of the rear seat.
- ▶ Fasten and wear safety belts properly ⇒ *page 264*.
- ▶ Make sure that children are always properly restrained in a child restraint that is appropriate for their size and age ⇒ *page 291*.

### WARNING

Passengers who are improperly seated on the rear seat can be seriously injured in a crash.

- Each passenger must always sit on a seat of their own and properly fasten and wear the safety belt belonging to that seat.
- Safety belts only offer maximum protection when the seatback is securely latched in the upright position and the safety belts are properly positioned on the body. By not sitting upright, a rear seat passenger increases the risk of personal injury from improperly positioned safety belts!
- Always adjust the head restraint properly so that it can give maximum protection.

### Proper adjustment of head restraints

*Correctly adjusted head restraints are an important part of your vehicle's occupant restraint system and can help to reduce the risk of injuries in accident situations.*

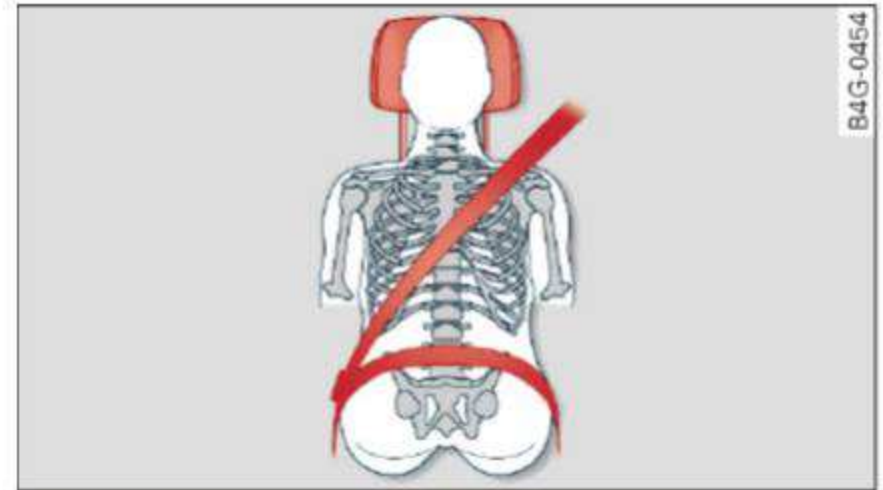

Fig. 220 Head restraint: viewed from the front

The head restraints must be correctly adjusted to achieve the best protection.

- ▶ Adjust the head restraints so the upper edge is as even as possible with the top of your head. If that is not possible, try to adjust the head restraint so that it is as close to this position as possible. Position\* the head restraint as close as possible to the back of your head.
- ▶ If there is a passenger in the center rear seat, slide the head restraint upward.

Adjusting head restraints ⇒ *page 58*.

### WARNING

All seats are equipped with head restraints. Driving without head restraints or with head restraints that are not properly adjusted increases the risk of serious or fatal neck injury dramatically. To help reduce the risk of injury:

- Always drive with the head restraints in place and properly adjusted.
- Every person in the vehicle must have a properly adjusted head restraint.
- Always make sure each person in the vehicle properly adjusts their head restraint. Adjust the head restraints so the upper edge is as even as possible with the top of your head. If that is not possible, try to adjust the head restraint so that it is as close to this position as possible.

- Never attempt to adjust head restraint while driving. If you have driven off and must adjust the driver headrest for any reason, first stop the vehicle safely before attempting to adjust the head restraint.
- Children must always be properly restrained in a child restraint that is appropriate for their age and size ⇒ *page 291*.

### Examples of improper seating positions

*The occupant restraint system can only reduce the risk of injury if vehicle occupants are properly seated.*

Improper seating positions can cause serious injury or death. Safety belts can only work when they are properly positioned on the body. Improper seating positions reduce the effectiveness of safety belts and will even increase the risk of injury and death by moving the safety belt to critical areas of the body. Improper seating positions also increase the risk of serious injury and death when an airbag deploys and strikes an occupant who is not in the proper seating position. A driver is responsible for the safety of all vehicle occupants and especially for children. Therefore:

- ▶ Never allow anyone to assume an incorrect seating position when the vehicle is being used ⇒ .

The following bulletins list only some sample positions that will increase the risk of serious injury and death. Our hope is that these examples will make you more aware of seating positions that are dangerous.

#### Therefore, whenever the vehicle is moving:

- never stand up in the vehicle
- never stand on the seats
- never kneel on the seats
- never ride with the seatback reclined
- never lie down on the seats
- never lean up against the instrument panel
- never sit on the edge of the seat
- never sit sideways
- never lean out the window
- never put your feet out the window

- never put your feet on the instrument panel
- never rest your feet on the seat cushion or back of the seat
- never ride in the footwell
- never ride in the cargo area

#### **WARNING**

Improper seating positions increase the risk of serious personal injury and death whenever a vehicle is being used.

- Always make sure that all vehicle occupants stay in a proper seating position and are properly restrained whenever the vehicle is being used.

## Pedal area

### Pedals

*The pedals must always be free to move and must never be interfered with by a floor mat or any other object.*

Make sure that all pedals move freely without interference and that nothing prevents them from returning to their original positions.

Only use floor mats that leave the pedal area free and can be secured with floor mat fasteners.

If a brake circuit fails, increased brake pedal travel is required to bring the vehicle to a full stop.

#### **WARNING**

Pedals that cannot move freely can cause loss of vehicle control and increase the risk of serious injury.

- Never place any objects in the driver's footwell. An object could get into the pedal area and interfere with pedal function. In case of sudden braking or an accident, you would not be able to brake or accelerate!
- Always make sure that nothing can fall or move into the driver's footwell.

## Floor mats on the driver side

Always use floor mats that can be securely attached to the floor mat fasteners and do not interfere with the free movement of the pedals.

- ▶ Make sure that the floor mats are properly secured and cannot move and interfere with the pedals ⇒ .

Use only floor mats that leave the pedal area unobstructed and that are firmly secured so that they cannot slip out of position. You can obtain suitable floor mats from your authorized Audi dealer.

Floor mat fasteners are installed in your Audi.

Floor mats used in your vehicle must be attached to these fasteners. Properly securing the floor mats will prevent them from sliding into positions that could interfere with the pedals or impair safe operation of your vehicle in other ways.

### WARNING

Pedals that cannot move freely can result in a loss of vehicle control and increase the risk of serious personal injury.

- Always make sure that floor mats are properly secured.
- Never place or install floor mats or other floor coverings in the vehicle that cannot be properly secured in place to prevent them from slipping and interfering with the pedals or the ability to control the vehicle.
- Never place or install floor mats or other floor coverings on top of already installed floor mats. Additional floor mats and other coverings will reduce the size of the pedal area and interfere with the pedals.
- Always properly reinstall and secure floor mats that have been taken out for cleaning.
- Always make sure that objects cannot fall into the driver footwell while the vehicle is moving. Objects can become trapped under the brake pedal and accelerator pedal causing a loss of vehicle control.

## Storing cargo correctly

### Loading the luggage compartment

All luggage and other objects must be properly stowed and secured in the luggage compartment.

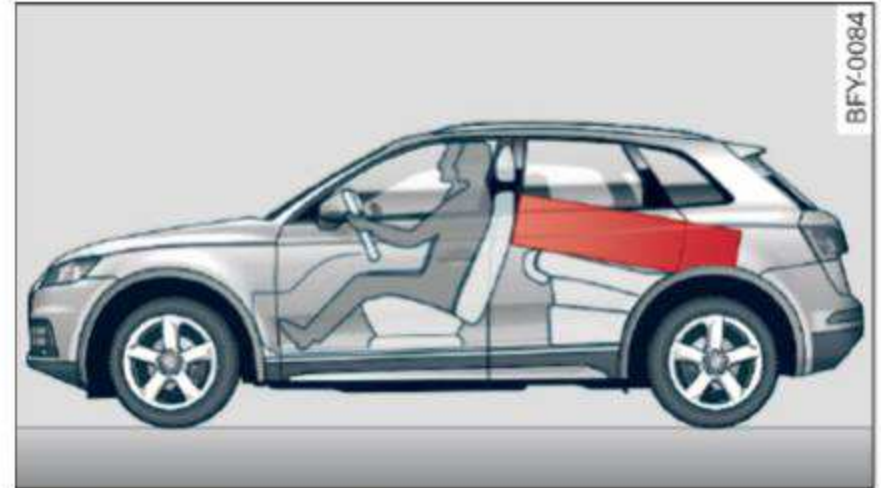

**Fig. 221** Safe load positioning: place heavy objects as low and as far forward as possible.

Loose items in the luggage compartment can shift suddenly, changing vehicle handling characteristics. Loose items can also increase the risk of serious personal injury in a sudden vehicle maneuver or in a collision.

- ▶ Distribute the load evenly in the luggage compartment.
- ▶ Always place and properly secure heavy items in the luggage compartment as low and as far forward as possible ⇒ *fig. 221*.
- ▶ Secure luggage using the tie-downs provided ⇒ *page 65*.
- ▶ Make sure that the rear seatback is securely latched in place.

### WARNING

Improperly stored luggage or other items can fly through the vehicle causing serious personal injury in the event of hard braking or an accident. To help reduce the risk of serious personal injury:

- Always put objects, for example, luggage or other heavy items in the luggage compartment.
- Always secure objects in the luggage compartment using the tie-down eyelets and suitable straps.

### **WARNING**

Heavy loads will influence the way your vehicle handles. To help reduce the risk of a loss of control leading to serious personal injury:

- Always keep in mind when transporting heavy objects, that a change in the center of gravity can also cause changes in vehicle handling:
  - Always distribute the load as evenly as possible.
  - Place heavy objects as far forward in the luggage compartment as possible.
- Never exceed the Gross Axle Weight Rating or the Gross Vehicle Weight Rating specified on the safety compliance sticker on the driver's side B-pillar. Exceeding permissible weight standards can cause the vehicle to slide and handle differently.
- Please observe information on safe driving ⇒ *page 252*.

### **WARNING**

To help prevent poisonous exhaust gas from being drawn into the vehicle, always keep the rear lid closed while driving.

- Never transport objects larger than those fitting completely into the luggage area because the rear lid cannot be fully closed.
- If you absolutely must drive with the rear lid open, observe the following notes to reduce the risk of poisoning:
  - Close all windows,
  - Close the sunroof\*,
  - Open all air outlets in the instrument panel,
  - Switch off the air recirculation,
  - Set the fresh air fan to the highest speed.

### **WARNING**

Always make sure that the doors, all windows, the sunroof\* and the rear lid are securely closed and locked to reduce the risk of injury when the vehicle is not being used.

- After closing the rear lid, always make sure that it is properly closed and locked.

- Never leave your vehicle unattended especially with the rear lid left open. A child could crawl into the vehicle through the luggage compartment and close the rear lid becoming trapped and unable to get out. Being trapped in a vehicle can lead to serious personal injury.
- Never let children play in or around the vehicle.
- Never let passengers ride in the luggage compartment. Vehicle occupants must always be properly restrained in one of the vehicle's seating positions.

### **Note**

If you are transporting large items with the backrest folded down\*, you should remove the Rear Seat Entertainment (RSE)\* and its holder\* to avoid damage.

### **Tips**

- Air circulation helps to reduce window fogging. Stale air escapes to the outside through vents in the trim panel. Be sure to keep these slots free and open.
- The tire pressure must correspond to the load. The tire pressure label lists the recommended cold tire inflation pressures for the vehicle at its maximum capacity weight and the tires that were on your vehicle at the time it was manufactured. For recommended tire pressures for normal load conditions, please see chapter ⇒ *page 336*.

### **Tie-downs**

*The luggage compartment is equipped with four tie-downs to secure luggage and other items.*

Use the tie-downs to secure your cargo properly ⇒ *page 257, Loading the luggage compartment*.

In a collision, the laws of physics mean that even smaller items that are loose in the vehicle will become heavy missiles that can cause serious injury. Items in the vehicle possess energy which vary with vehicle speed and the weight of the item. Vehicle speed is the most significant factor. ►

For example, in a frontal collision at a speed of 30 mph (48 km/h), the forces acting on a 10-lb (4.5 kg) object are about 20 times the normal weight of the item. This means that the weight of the item would suddenly be about 200 lbs. (90 kg). You can imagine the injuries that a 200 lbs. (90 kg) item flying freely through the passenger compartment could cause in a collision like this.

### **WARNING**

Weak, damaged or improper straps used to secure items to tie-downs can fail during hard braking or in a collision and cause serious personal injury.

- Always use suitable mounting straps and properly secure items to the tie-downs in the luggage compartment to help prevent items from shifting or flying forward as dangerous missiles.
- When the rear seat backrest is folded down, always use suitable mounting straps and properly secure items to the tie-downs in the luggage compartment to help prevent items from flying forward as dangerous missiles into the passenger compartment.
- Never attach a child safety seat tether strap to a tie-down.

## **Reporting Safety Defects**

### **Applicable to U.S.A.**

If you believe that your vehicle has a defect which could cause a crash or could cause injury or death, you should immediately inform the National Highway Traffic Safety Administration (NHTSA) in addition to notifying Audi of America, Inc.

If NHTSA receives similar complaints, it may open an investiga-

tion, and if it finds that a safety defect exists in a group of vehicles, it may order a recall and remedy campaign. However, NHTSA cannot become involved in individual problems between you, your dealer, or Audi of America, Inc.

To contact the NHTSA, you may either call:

Tel.: 1-888-327-4236 (TTY:  
1-800-424-9153) or  
1-800-424-9393

or you may write to:

NHTSA  
U.S. Department of Transportation  
1200 New Jersey Ave., S.E.  
West Building  
Washington, DC 20590

You can also obtain other information about motor vehicle safety from:

<http://www.safercar.gov>

### **Applicable to Canada**

If you live in Canada and you believe that your vehicle has a defect that could cause a crash, injury or death, you should immediately inform Transport Canada, Defect Investigations and Recalls. ►

You should also notify Audi Canada.

Canadian customers who wish to report a safety-related defect to Transport Canada, Defect Investigations and Recalls, may either call Transport Canada toll-free at:

Tel.: 1-800-333-0510 or

Tel.: 1-819-994-3328 (Ottawa region and from other countries)

TTY for hearing impaired:

1-888-675-6863

or contact Transport Canada by mail at:

Transport Canada  
Motor Vehicle Safety Investigations Laboratory  
80 Noel Street  
Gatineau, QC  
J8Z 0A1

For additional road safety information, please visit the Road Safety website at:

<http://www.tc.gc.ca/eng/roadsafety/menu.htm>

## Safety belts

### General information

#### Always wear safety belts!

*Wearing safety belts correctly saves lives!*

This chapter explains why safety belts are necessary, how they work and how to adjust and wear them correctly.

- ▶ Read all the information that follows and heed all of the instructions and WARNINGS.

#### WARNING

Not wearing safety belts or wearing them improperly increases the risk of serious personal injury and death.

- Safety belts are the single most effective means available to reduce the risk of serious injury and death in automobile accidents. For your protection and that of your passengers, always correctly wear safety belts when the vehicle is moving.
- Pregnant women, injured, or physically impaired persons must also use safety belts. Like all vehicle occupants, they are more likely to be seriously injured if they do not wear safety belts. The best way to protect a fetus is to protect the mother – throughout the entire pregnancy.

#### Number of seats

Your Audi has a total of five seating positions: two in the front and three in the rear. Each seating position has a safety belt.

#### WARNING

Not wearing safety belts or wearing them improperly increases the risk of serious personal injury and death.

- Never strap more than one person, including small children, into any belt. It is especially dangerous to place a safety belt over a child sitting on your lap.
- Never let more people ride in the vehicle than there are safety belts available.

- Be sure everyone riding in the vehicle is properly restrained with a separate safety belt or child restraint.

#### Safety belt warning light

*Your vehicle has a warning system for the driver and front seat passenger to remind you about the importance of buckling-up.*



Fig. 222 Safety belt warning light in the instrument cluster – enlarged

#### Before driving off, always:

- ▶ Fasten your safety belt and make sure you are wearing it properly.
- ▶ Make sure that your passengers also buckle up and properly wear their safety belts.
- ▶ Protect children with a child restraint system appropriate for the size and age.

The warning light  in the instrument cluster lights up when the ignition is switched on as a reminder to fasten the safety belts. In addition, you will hear a warning tone for a certain period of time.

**Fasten your safety belt and make sure that your passengers also properly put on their safety belts.**

#### WARNING

- Safety belts are the single most effective means available to reduce the risk of serious injury and death in automobile accidents. For your protection and that of your passengers, always correctly wear safety belts when the vehicle is moving.
- Failure to pay attention to the warning light that comes on could lead to personal injury.

## Why use safety belts?

### Frontal collisions and the law of physics

*Frontal crashes create very strong forces for people riding in vehicles.*

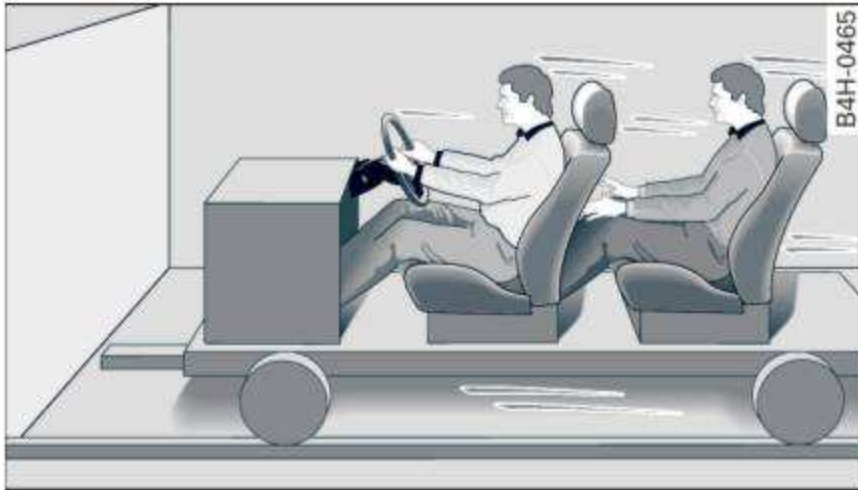

**Fig. 223** Unbelted occupants in a vehicle heading for a wall



**Fig. 224** The vehicle crashes into the wall

The physical principles are simple. Both the vehicle and the passengers possess energy which varies with vehicle speed and body weight. Engineers call this energy “kinetic energy.”

The higher the speed of the vehicle and the greater the vehicle's weight, the more energy that has to be “absorbed” in the crash.

Vehicle speed is the most significant factor. If the speed doubles from 15 to 30 mph (25 to 50 km/h), the energy increases 4 times!

Because the passengers of this vehicle are not using safety belts ⇒ *fig. 223*, they will keep moving at the same speed the vehicle was moving just before the crash, until something stops them – here, the wall ⇒ *fig. 224*.

The same principles apply to people sitting in a vehicle that is involved in a frontal collision. Even at city speeds of 20 to 30 mph (30 to 50 km/h), the forces acting on the body can reach one ton

(2,000 lbs. or 1,000 kg) or more. At greater speeds, these forces are even higher.

People who do not use safety belts are also not attached to their vehicle. In a frontal collision they will also keep moving forward at the speed their vehicle was travelling just before the crash. Of course, the laws of physics don't just apply to frontal collisions, they determine what happens in all kinds of accidents and collisions.

### What happens to occupants not wearing safety belts?

*In crashes unbelted occupants cannot stop themselves from flying forward and being injured or killed. Always wear your safety belts!*



**Fig. 225** A driver not wearing a safety belt is violently thrown forward



**Fig. 226** A rear passenger not wearing a safety belt will fly forward and strike the driver

Unbelted occupants are not able to resist the tremendous forces of impact by holding tight or bracing themselves. Without the benefit of safety restraint systems, the unrestrained occupant will slam violently into the steering wheel, instrument panel, windshield, or whatever else is in the way ⇒ *fig. 225*. This impact with the vehicle interior has all the energy they had just before the crash.

Never rely on airbags alone for protection. Even when they deploy, airbags provide only additional protection. Airbags are not supposed to deploy in all kinds of accidents. Although your Audi is equipped with airbags, all vehicle occupants, including the driver, must wear safety belts correctly in order to minimize the risk of severe injury or death in a crash.

Remember too, that airbags will deploy only once and that your safety belts are always there to offer protection in those accidents in which airbags are not supposed to deploy or when they have already deployed. Unbelted occupants can also be thrown out of the vehicle where even more severe or fatal injuries can occur.

It is also important for the rear passengers to wear safety belts correctly. Unbelted passengers in the rear seats endanger not only themselves but also the driver and other passengers ⇒ *fig. 226*. In a frontal collision they will be thrown forward violently, where they can hit and injure the driver and/or front seat passenger.

### Safety belts protect

*People think it's possible to use the hands to brace the body in a minor collision. It's simply not true!*



**Fig. 227** Driver is correctly restrained in a sudden braking maneuver

Safety belts used properly can make a big difference. Safety belts help to keep passengers in their seats, gradually reduce energy levels applied to the body in an accident, and help prevent the uncontrolled movement that can cause serious injuries. In addition, safety belts reduce the danger of being thrown out of the vehicle.

Safety belts attach passengers to the car and give them the benefit of being slowed down more gently or “softly” through the “give” in the safety belts, crush zones and other safety features engineered into today's vehicles. By “absorbing” the kinetic energy over a longer period of time, the safety belts make the forces on the body more “tolerable” and less likely to cause injury.

Although these examples are based on a frontal collision, safety belts can also substantially reduce the risk of injury in other kinds of crashes. So, whether you're on a long trip or just going to the corner store, always buckle up and make sure others do, too. Accident statistics show that vehicle occupants properly wearing safety belts have a lower risk of being injured and a much better chance of surviving an accident. Properly using safety belts also greatly increases the ability of the supplemental airbags to do their job in a collision. For this reason, wearing a safety belt is legally required in most countries including much of the United States and Canada.

Although your Audi is equipped with airbags, you still have to wear the safety belts provided. Front airbags, for example, are activated only in some frontal collisions. The front airbags are not activated in all frontal collisions, in side and rear collisions, in rollovers or in cases where there is not enough deceleration through impact to the front of the vehicle. The same goes for the other airbag systems in your Audi. So, always wear your safety belt and make sure everybody in your vehicle is properly restrained!

### Important safety instructions about safety belts

*Safety belts must always be correctly positioned across the strongest bones of your body.*

- ▶ Always wear safety belts as illustrated and described in this chapter.
- ▶ Make sure that your safety belts are always ready for use and are not damaged.

### WARNING

Not wearing safety belts or wearing them improperly increases the risk of serious personal injury and death. Safety belts can work only when used correctly.

- Always fasten your safety belts correctly before driving off and make sure all passengers are correctly restrained.
- For maximum protection, safety belts must always be positioned properly on the body.
- Never strap more than one person, including small children, into any belt.
- Never place a safety belt over a child sitting on your lap.
- Always keep feet in the footwell in front of the seat while the vehicle is being driven.
- Never let any person ride with their feet on the instrument panel or sticking out the window or on the seat.
- Never remove a safety belt while the vehicle is moving. Doing so will increase your risk of being injured or killed.
- Never wear belts twisted.
- Never wear belts over rigid or breakable objects in or on your clothing, such as eye glasses, pens, keys, etc., as these may cause injury.
- Never allow safety belts to become damaged by being caught in door or seat hardware.
- Do not wear the shoulder part of the belt under your arm or otherwise out of position.
- Several layers of heavy clothing may interfere with correct positioning of belts and reduce the overall effectiveness of the system.
- Always keep belt buckles free of anything that may prevent the buckle from latching securely.
- Never use comfort clips or devices that create slack in the shoulder belt. However, special clips may be required for the proper use of some child restraint systems.
- Torn or frayed safety belts can tear, and damaged belt hardware can break in an accident. Inspect belts regularly. If webbing, bindings, buckles, or retractors are dam-

aged, have belts replaced by an authorized Audi dealer or qualified workshop.

- Safety belts that have been worn and loaded in an accident must be replaced with the correct replacement safety belt by an authorized Audi dealer. Replacement may be necessary even if damage cannot be clearly seen. Anchorages that were loaded must also be inspected.
- Never remove, modify, disassemble, or try to repair the safety belts yourself.
- Always keep the belts clean. Dirty belts may not work properly and can impair the function of the inertia reel ⇒ *table Interior cleaning on page 346.*

## Safety belts

### Fastening safety belts

*Safety first – everybody buckle up!*

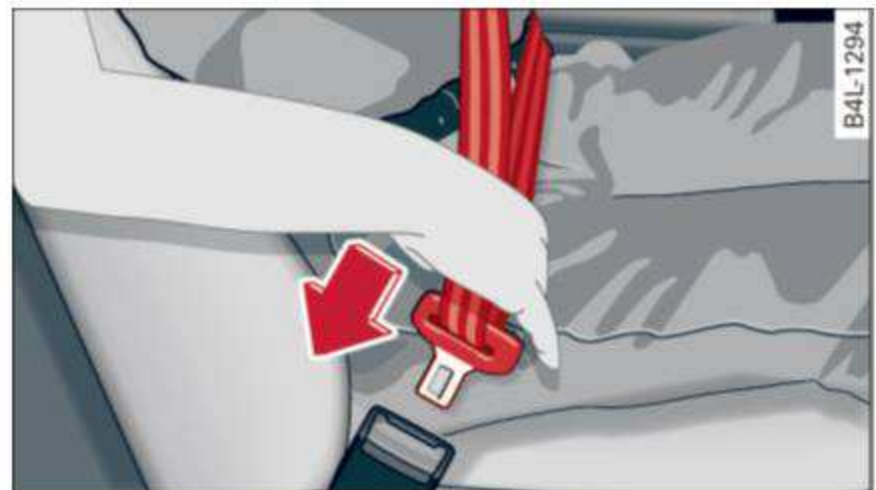



Fig. 228 Belt buckle and tongue on the driver's seat

To provide maximum protection, safety belts must always be positioned correctly on the wearer's body.

- ▶ Adjust the front seat and head restraint properly ⇒ *page 56, Front seats.*
- ▶ Make sure the seatback of the rear seat bench is in an upright position and securely latched in place before using the belt ⇒ .
- ▶ Pull the safety belt evenly across the chest and pelvis ⇒ *fig. 228*, ⇒ .
- ▶ Insert the tongue into the correct buckle of your seat until you hear it latch securely.
- ▶ Pull on the belt to make sure that it is securely latched in the buckle. ▶

### Automatic safety belt retractors

Every safety belt is equipped with an automatic belt retractor on the shoulder belt. This feature locks the belt when the belt is pulled out fast, during hard braking and in an accident. The belt may also lock when you drive up or down a steep hill or through a sharp curve. During normal driving the belt lets you move freely.

### Safety belt pretensioners

Safety belts with pretensioners help to tighten the safety belt and remove slack when the pretensioners are activated ⇒ *page 267*. The function of the pretensioner is monitored by a warning light ⇒ *page 26*.

### Convertible locking retractor

Every safety belt except the one on the driver seat is equipped with a convertible locking retractor that **must** be used when the safety belt is used to attach a child safety seat. Be sure to read the important information about this feature ⇒ *page 302*.

#### WARNING

Improperly positioned safety belts can cause serious injury in an accident ⇒ *page 265*, *Safety belt position*.

- Safety belts offer optimum protection only when the seatback is upright and belts are properly positioned on the body.
- Always make sure that the rear seat backrest to which the center rear safety belt is attached is securely latched whenever the rear center safety belt is being used. If the backrest is not securely latched, the passenger will move forward with the backrest during sudden braking, in a sudden maneuver and especially in a crash.
- Never attach the safety belt to the buckle for another seat. Attaching the belt to the wrong buckle will reduce safety belt effectiveness and can cause serious personal injury.
- A passenger who is not properly restrained can be seriously injured by the safety belt itself when it moves from the stronger parts

of the body into critical areas like the abdomen.

- Always lock the convertible locking retractor when you are securing a child safety seat in the vehicle ⇒ *page 304*.

### Safety belt position

*Correct belt position is the key to getting maximum protection from safety belts.*

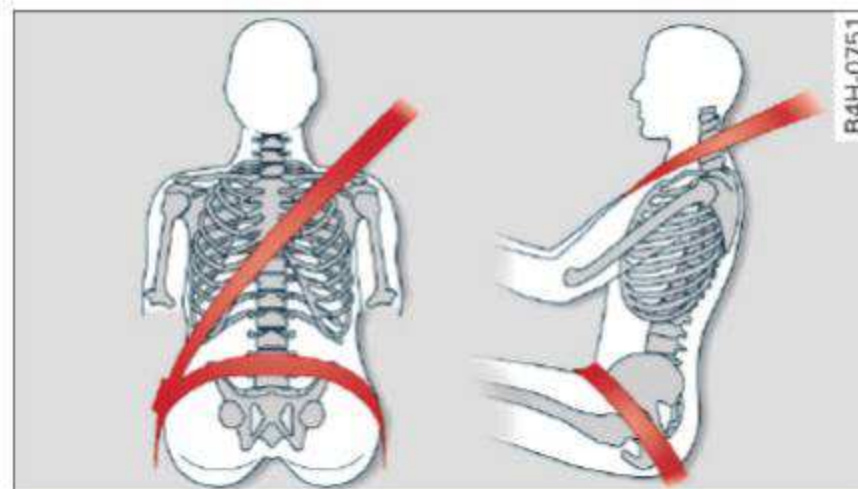

Fig. 229 Safety belt position

Standard features on your vehicle help you adjust the position of the safety belt to match your body size.

- belt height adjustment for the front seats,
- height-adjustable front seats.

#### WARNING

Improperly positioned safety belts can cause serious personal injury in an accident.

- The shoulder belt should lie as close to the center of the collar bone as possible and should fit well on the body. Hold the belt above the latch tongue and pull it evenly across the chest so that it sits as low as possible on the pelvis and there is no pressure on the abdomen. The belt should always fit snugly ⇒ *fig. 229*. Pull on the belt to tighten if necessary.
- The lap belt portion of the safety belt must be positioned as low as possible across pelvis and never over the abdomen. Make sure the belt lies flat and snug ⇒ *fig. 229*. Pull on the belt to tighten if necessary.
- A loose-fitting safety belt can cause serious injuries by shifting its position on your body

## Safety belts

- from the strong bones to more vulnerable, soft tissue and cause serious injury.
- Always read and heed all WARNINGS and other important information ⇒ *page 263*.

### Pregnant women must also be correctly restrained

The best way to protect the fetus is to make sure that expectant mothers always wear safety belts correctly – throughout the pregnancy.



Fig. 230 Safety belt position during pregnancy

To provide maximum protection, safety belts must always be positioned correctly on the wearer's body ⇒ *page 265*.

- ▶ Adjust the front seat and head restraint correctly ⇒ *page 56, Front seats*.
- ▶ Make sure the seatback of the rear seat bench is in an upright position and securely latched in place before using the belt.
- ▶ Pull the safety belt evenly across the chest so that it sits as low as possible on the pelvis and there is no pressure on the abdomen ⇒ *fig. 230*, ⇒ ⚠.
- ▶ Insert the tongue into the correct buckle of your seat until you hear it latch securely.
- ▶ Pull on the belt to make sure that it is securely latched in the buckle.

### ⚠ WARNING

- Improperly positioned safety belts can cause serious personal injury in an accident.
- Expectant mothers must always wear the lap portion of the safety belt as low as possible across the pelvis and below the rounding of the abdomen.

- Always read and heed all WARNINGS and other important information ⇒ ⚠ in *Fastening safety belts on page 265*.

### Unfastening safety belts

Unbuckle the safety belt with the red release button only after the vehicle has stopped.



Fig. 231 Releasing the tongue from the buckle

- ▶ Push the red release button on the buckle ⇒ *fig. 231*. The belt tongue will spring out of the buckle ⇒ ⚠.
- ▶ Let the belt wind up on the retractor as you guide the belt tongue to its stowed position.

### ⚠ WARNING

Never unfasten safety belt while the vehicle is moving. Doing so will increase your risk of being injured or killed.

### Adjusting safety belt height

With the aid of the safety belt height adjustment, the three point safety belt strap routing can be fitted to the shoulder area, according to body size.

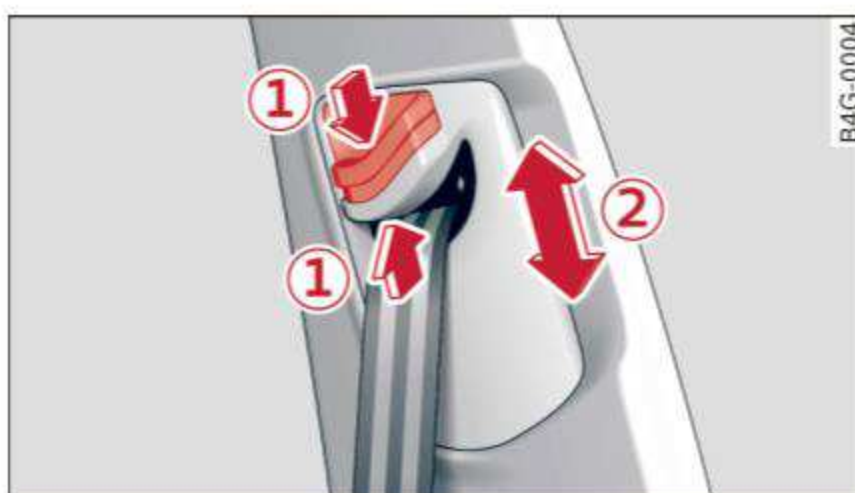





Fig. 232 Safety belt height adjustment – loop-around fittings

The shoulder belt should lie as close to the center of the collar bone as possible and should fit well on the body ⇒  in *Safety belt position on page 265*.

- ▶ Push the loop-around fittings **up** ⇒ *fig. 232* ,
- or
- ▶ squeeze together the  button, and push the loop-around fittings **down** .
- ▶ Pull the belt to make sure that the upper attachment is properly engaged.

### WARNING

Always read and heed all WARNINGS and other important information ⇒ *page 263*.

### Tips

With the front seats, the height adjustment of the seat can also be used to adjust the position of the safety belts.

## Improperly worn safety belts

*Incorrectly positioned safety belts can cause severe injuries.*

Wearing safety belts improperly can cause serious injury or death. Safety belts can only work when they are correctly positioned on the body. Improper seating positions reduce the effectiveness of safety belts and will even increase the risk of injury and death by moving the safety belt to critical areas of the body. Improper seating positions also increase the risk of serious injury and death when an airbag deploys and strikes an occupant who is not in the correct seating position. A driver is responsible for the safety of all vehicle occupants and especially for children. Therefore:

- ▶ Never permit anyone to assume an incorrect sitting position in the vehicle while traveling ⇒ .

### WARNING

Improperly worn safety belts increase the risk of serious personal injury and death whenever a vehicle is being used.

- Always make sure that all vehicle occupants are correctly restrained and stay in a correct seating position whenever the vehicle is being used.
- Always read and heed all WARNINGS and other important information ⇒ *page 263*.

## Belt tensioners

### How safety belt pretensioners work

#### Reversible safety belt pretensioners

The following functions are available when safety belts with reversible safety belt tensioners are fastened:

- In certain driving situations, the safety belts may tighten with a reversible tensioning function ⇒ *page 112*.
- The safety belts may also tighten with this reversible tensioning function in minor collisions.

#### Pyrotechnic safety belt pretensioners

Seat belts with pyrotechnic safety belt pretensioners are tensioned automatically in severe collisions, depending on the circumstances. This helps to reduce the forward motion of the occupants.

### WARNING

- It is possible for the pretensioners to deploy incorrectly.
- Any work on the tensioner system or removal and installation of system components for other repairs must be performed by a qualified workshop.
- The pyrotechnic system can only provide protection for one collision. If the pyrotechnic pretensioners deploy, the pretensioning system must be replaced.

### Tips

- A fine dust is released when the pyrotechnic safety belt pretensioners deploy. This is normal and is not caused by a fire in the vehicle.

- The relevant safety requirements must be observed when the vehicle or components of the system are scrapped. A qualified dealership is familiar with these regulations and will be pleased to pass on the information to you.

### Service and disposal of safety belt pretensioner

The safety belt pretensioners are parts of the safety belts on your Audi. Installing, removing, servicing or repairing of belt pretensioners can damage the safety belt system and prevent it from working correctly in a collision.

There are some important things you have to know to make sure that the effectiveness of the system will not be impaired and that discarded components do not cause injury or pollute the environment.

#### **WARNING**

Improper care, servicing and repair procedures can increase the risk of personal injury and death by preventing a safety belt pretensioner from activating when needed or activating it unexpectedly:

- The pyrotechnic safety belt pretensioners can only be activated once. If pyrotechnic safety belt pretensioners have been activated, the system must be replaced.
- Never repair, adjust, or change any parts of the safety belt system.
- Safety belt systems including safety belt pretensioners cannot be repaired. Special procedures are required for removal, installation and disposal of this system.
- For any work on the safety belt system, we strongly recommend that you see your authorized Audi dealer or qualified technician who has an Audi approved repair manual, training and special equipment necessary.

#### **For the sake of the environment**

Undeployed airbag modules and pretensioners might be classified as Perchlorate Material -special handling may apply, see [www.dtsc.ca.gov/hazardouswaste/perchlorate](http://www.dtsc.ca.gov/hazardouswaste/perchlorate)

rate. When the vehicle or parts of the restraint system including airbag modules safety belts with pretensioners are scrapped, all applicable laws and regulations must be observed. Your authorized Audi dealer is familiar with these requirements and we recommend that you have your dealer perform this service for you.

## Airbag system

### Important information

#### Importance of wearing safety belts and sitting properly

*Airbags are only supplemental restraints. For airbags to do their job, occupants must always properly wear their safety belts and be in a proper seating position.*

For your safety and the safety of your passengers, before driving off, always:

- ▶ Adjust the driver's seat and steering wheel properly ⇒ *page 253*,
- ▶ Adjust the front passenger's seat properly ⇒ *page 254*,
- ▶ Wear safety belts properly ⇒ *page 263*,
- ▶ Always properly use the proper child restraint to protect children ⇒ *page 291*.

In a collision, airbags must inflate within the blink of an eye and with considerable force. The supplemental airbags can cause injuries if the driver or the front seat passenger is not seated properly. Therefore in order to help the airbag to do its job, it is important, both as a driver and as a passenger to sit properly at all times.

By keeping room between your body and the steering wheel and the front of the passenger compartment, the airbag can inflate fully and completely and provide supplemental protection in certain frontal collisions ⇒ *page 253*, *Correct passenger seating positions*. For details on the operation of the seat adjustment controls ⇒ *page 56*.

It's especially important that children are properly restrained ⇒ *page 291*.

There is a lot that the driver and the passengers can and must do to help the individual safety features installed in your Audi work together as a system.

Proper seating position is important so that the front airbag on the driver side can do its job. If you have a physical impairment or condition that prevents you from sitting properly on the driver seat with the safety belt properly fastened and

reaching the pedals, or if you have concerns with regard to the function or operation of the Advanced Airbag System, please contact your authorized Audi dealer or qualified workshop, or call Audi Customer Relations at 1-800-822-2834 for possible modifications to your vehicle.

When the airbag system deploys, a gas generator will fill the airbags, break open the padded covers, and inflate between the steering wheel and the driver and between the instrument panel and the front passenger. The airbags will deflate immediately after deployment so that the front occupants can see through the windshield again without interruption.

All of this takes place in the blink of an eye, so fast that many people don't even realize that the airbags have deployed. The airbags also inflate with a great deal of force and nothing should be in their way when they deploy. Front airbags in combination with properly worn safety belts slow down and limit the occupant's forward movement. Together they help to prevent the driver and front seat passenger from hitting parts of the inside of the vehicle while reducing the forces acting on the occupant during the crash. In this way they help to reduce the risk of injury to the head and upper body in the crash. Airbags do not protect the arms or the lower parts of the body.

Both front airbags will not inflate in all frontal collisions. The triggering of the airbag system depends on the vehicle deceleration rate caused by the collision and registered by the electronic control unit. If this rate is below the reference value programmed into the control unit, the airbags will not be triggered, even though the car may be badly damaged as a result of the collision. Vehicle damage, repair costs or even the lack of vehicle damage is not necessarily an indication of whether an airbag should inflate or not.

Since the circumstances will vary considerably between one collision and another, it is not possible to define a range of vehicle speeds that will cover every possible kind and angle of impact that will always trigger the airbags. Important factors include, for example, the nature (hard or soft) of the object which the car hits, the angle of impact, vehicle speed, etc. The front airbags will ►

## Airbag system

also not inflate in side or rear collisions, or in rollovers.

**Always remember:** Airbags will deploy only once, and only in certain kinds of collisions. Your safety belts are always there to offer protection in those situations in which airbags are not supposed to deploy, or when they have already deployed; for example, when your vehicle strikes or is struck by another vehicle after the first collision.

This is just one of the reasons why an airbag is a supplementary restraint and is not a substitute for a safety belt. The airbag system works most effectively when used with the safety belts. Therefore, always properly wear your safety belts ⇒ *page 261*.

### **WARNING**

Sitting too close to the steering wheel or instrument panel will decrease the effectiveness of the airbags and will increase the risk of personal injury in a collision.

- Never sit closer than 10 inches (25 cm) to the steering wheel or instrument panel.
- If you cannot sit more than 10 inches (25 cm) from the steering wheel, investigate whether adaptive equipment may be available to help you reach the pedals and increase your seating distance from the steering wheel.
- All vehicle occupants and especially children must be restrained properly whenever riding in a vehicle. An unrestrained or improperly restrained child could be injured by striking the interior or by being ejected from the vehicle during a sudden maneuver or impact. An unrestrained or improperly restrained child is also at greater risk of injury or death through contact with an inflating airbag.
- If you are unrestrained, leaning forward, sitting sideways or out of position in any way, your risk of injury is much higher.
- You will also receive serious injuries and could even be killed if you are up against the airbag or too close to it when it inflates - even with an Advanced Airbag.

- To reduce the risk of injury when an airbag inflates, always wear safety belts properly ⇒ *page 264, Safety belts*.
- Always make certain that children age 12 or younger always ride in the rear seat. If children are not properly restrained, they may be severely injured or killed when an airbag inflates.
- Never let children ride unrestrained or improperly restrained in the vehicle. Adjust the front seats properly.
- Never ride with the backrest reclined.
- Always sit as far as possible from the steering wheel or the instrument panel ⇒ *page 253*.
- Always sit upright with your back against the backrest of your seat.
- Never place your feet on the instrument panel or on the seat. Always keep both feet on the floor in front of the seat to help prevent serious injuries to the legs and hips if the airbag inflates.
- Never recline the front passenger's seat to transport objects. Items can also move into the area of the side airbag or the front airbag during braking or in a sudden maneuver. Objects near the airbags can become projectiles and cause injury when an airbag inflates.

### **WARNING**

Airbags that have deployed in a crash must be replaced.

- Use only original equipment airbags approved by Audi and installed by a trained technician who has the necessary tools and diagnostic equipment to properly replace any airbag in your vehicle and assure system effectiveness in a crash.
- Never permit salvaged or recycled airbags to be installed in your vehicle.

### **Child restraints on the front seat – some important things to know**

- ▶ Be sure to read the important information and heed the WARNINGS for important details ▶



about children and Advanced Airbags



⇒ *page 291*.



Even though your vehicle is equipped with an Advanced Airbag System, make certain that all children, especially those 12 years and younger, always ride in the back seat properly restrained for their age and size. The airbag on the passenger side makes the front seat a potentially dangerous place for a child to ride. The front seat is not the safest place for a child in a forward-facing child safety seat. It can be a very dangerous place for an infant or a child in a rearward-facing seat.

The Advanced Airbag System in your vehicle has been certified to comply with the requirements of United States Federal Motor Vehicle Safety Standard (FMVSS) 208, as well as Canada Motor Vehicle Safety Standard (CMVSS) 208 as applicable at the time your vehicle was manufactured. According to requirements, the front Advanced Airbag System on the passenger side has been certified for “suppression” for infants of about 12 month old and younger and for “low risk deployment” for children aged 3 to 6 years old (as defined in the standard).

The **PASSENGER AIR BAG OFF**  light in the headliner tells you when the front Advanced Airbag on the passenger side has been turned off by the electronic control unit.

Each time you turn on the ignition, the **PASSENGER AIR BAG OFF**  **ON**  light will come on for a few seconds and:

- **PASSENGER AIR BAG OFF**  will come on if the front passenger seat is not occupied
- **PASSENGER AIR BAG OFF**  will come on if the electrical capacitance measured by the capacitive passenger detection system for the front passenger seat equals the combined capacitance of an infant up to about one year of age and one of the rearward-facing or forward-facing child restraints listed in Federal Motor Vehicle Safety Standard (FMVSS) 208 with which the Advanced Airbag System in your vehicle was certified. For a listing of the child restraints that were used to certify your vehicle's compliance with the Safety Standard ⇒ *page 293*.

- **PASSENGER AIR BAG OFF**  will come on if there is a small child or child restraint on the front passenger seat
- **PASSENGER AIR BAG ON**  will come on if the front passenger seat is occupied by an adult as registered by the capacitive passenger detection system ⇒ *page 281, Monitoring the Advanced Airbag System*.

The **PASSENGER AIR BAG OFF**  light comes on when electrical capacitance registered on the front passenger seat is equal to or less than the combined capacitance of a typical 1 year-old infant and one of the rearward-facing or forward-facing child restraints listed in Federal Motor Vehicle Safety Standard (FMVSS) 208 with which the Advanced Airbag System in your vehicle was certified.

If the total electrical capacitance registered on the front passenger seat is more than that of a typical 1 year-old child but less than the weight of a small adult, the front airbag on the passenger side can deploy (the **PASSENGER AIR BAG OFF**  light does not come on).



If the **PASSENGER AIR BAG OFF**  light does not come on, the front airbag on the passenger side has not been turned off by the electronic control unit and can deploy if the control unit senses an impact that meets the conditions stored in its memory.

**For example, the airbag may deploy if:**

- a small child that is heavier than a typical 1 year-old child is on the front passenger seat (regardless of whether the child is in one of the child safety seats listed ⇒ *page 293*), or
- a child who has outgrown child restraints is on the front passenger seat.

If the front passenger airbag is turned off, the **PASSENGER AIR BAG OFF**  light comes on in the headliner and stays on.

If the front passenger airbag deploys, the Federal Standard requires the airbag to meet the “low risk” deployment criteria to reduce the risk of injury through interaction with the airbag. “Low risk” deployment occurs in those crashes that take place at lower decelerations as defined in

the electronic control unit ⇒ *page 281, PASSENGER AIR BAG OFF*  *ON*  *light.*

Always remember, a child safety seat or infant carrier installed on the front seat may be struck and knocked out of position by the rapidly inflating passenger's airbag in a frontal collision. The airbag could greatly reduce the effectiveness of the child restraint and even seriously injure the child during inflation.

For this reason, and because the back seat is the safest place for children - when properly restrained according to their age and size - we strongly recommend that children always sit in the back seat ⇒ *page 291, Child safety.*

### **WARNING**

A child in a rearward-facing child safety seat installed on the front passenger seat will be seriously injured and can be killed if the front airbag inflates - even with an Advanced Airbag System.

- The inflating airbag will hit the child safety seat or infant carrier with great force and will smash the child safety seat and child against the backrest, center armrest, door or roof.
- Always install rear-facing child safety seats on the rear seat.
- If you must install a rearward facing child safety seat on the front passenger seat because of exceptional circumstances and the **PASSENGER AIR BAG OFF**  light does not come on and stay on, immediately install the rear-facing child safety seat in a rear seating position and have the airbag system inspected by your authorized Audi dealer.
- Forward-facing child safety seats installed on the front passenger's seat may interfere with the deployment of the airbag and cause serious personal injury to the child.

### **WARNING**

If, in exceptional circumstances, you must install a forward-facing child restraint on the front passenger's seat:



- Always make sure the forward-facing seat has been designed and certified by its man-

ufacturer for use on a front seat with a passenger front and side airbag.

- Never put the forward-facing child restraint up against or very near the instrument panel.
- Always move the front passenger seat to the highest position in the up and down adjustment range and move it back to the rearmost position in the seat's fore and aft adjustment range, as far away from the airbag as possible, before installing the forward-facing child restraint.
- Always make sure that the safety belt upper anchorage is behind the child restraint and not next to or in front of the child restraint so that the safety belt will be properly positioned.
- Make sure that the **PASSENGER AIR BAG OFF**  light comes on and stays on all the time whenever the ignition is switched on.

### **WARNING**

To reduce the risk of serious injury, make sure that the **PASSENGER AIR BAG OFF**  light will be displayed whenever a child restraint is installed on the front passenger seat and the ignition is switched on.

- If the **PASSENGER AIR BAG OFF**  light does not stay on, perform the checks described ⇒ *page 281, Monitoring the Advanced Airbag System.*
- Take the child restraint off the front passenger seat and install it properly at one of the rear seat positions if the **PASSENGER AIR BAG OFF**  light does not stay on.
- Have the airbag system inspected by your authorized Audi dealer immediately.
- Always carefully follow instructions from child restraint manufacturers when installing child restraints.

### **WARNING**

If, in exceptional circumstances, you must install a forward or rearward-facing child restraint on the front passenger's seat:

- Improper installation of child restraints can reduce their effectiveness or even prevent them from providing any protection.
- An improperly installed child restraint can interfere with the airbag as it deploys and seriously injure or even kill the child – even with an Advanced Airbag System.
- Always carefully follow the manufacturer's instructions provided with the child safety seat or carrier.
- Always make sure that there is nothing on the front passenger seat that will cause the capacitive passenger detection system in the seat to signal to the Airbag System that the seat is occupied by a person when it is not, or to signal that it is occupied by someone who is heavier than the person actually sitting on the seat. The presence of additional objects could cause the passenger front airbag to be turned on when it should be off, or could cause the airbag to work in a way that is different from the way it would have worked without the object on the seat.

## Front airbags

### Description of front airbags

The airbag system can provide supplemental protection to properly restrained front seat occupants.



Fig. 233 Location of driver airbag: in steering wheel

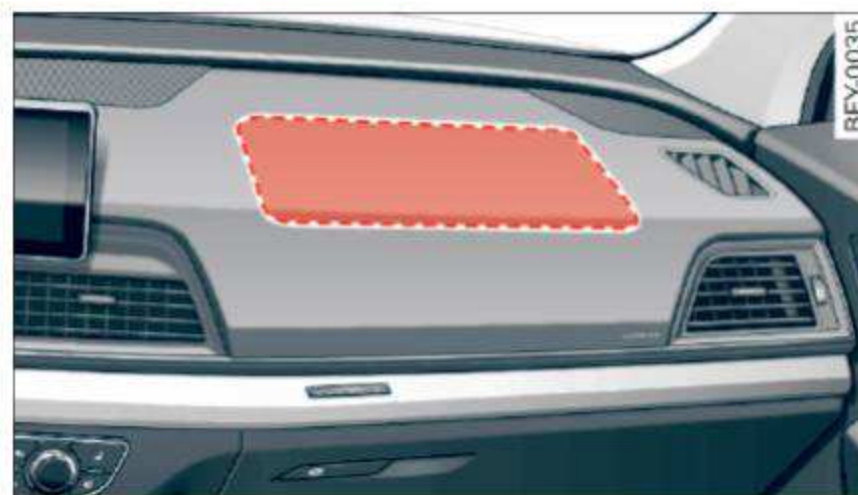

Fig. 234 Location of front passenger's airbag: in the instrument panel

Your vehicle is equipped with an “Advanced Airbag System” in compliance with United States Federal Motor Vehicle Safety Standard (FMVSS) 208, as well as Canada Motor Vehicle Safety Standard (CMVSS) 208 as applicable at the time your vehicle was manufactured.

The airbag for the driver is in the steering wheel hub ⇒ fig. 233 and the airbag for the front passenger is in the instrument panel ⇒ fig. 234. The general location of the airbags is marked “AIR-BAG”.

There is a lot you need to know about the airbags in your vehicle. We urge you to read the detailed information about airbags, safety belts and child safety in this and the other chapters that make up the owner's literature. Please be sure to heed the WARNINGS - they are extremely important for your safety and the safety of your passengers, especially infants and small children.

### WARNING

- Never rely on airbags alone for protection.
- Even when they deploy, airbags provide only supplemental protection.
- Airbags work most effectively when used with properly worn safety belts.
- Therefore, always wear your safety belts and make sure that everybody in your vehicle is properly restrained.
- Always hold the steering wheel with both hands on the outside of the steering wheel rim at the 9:00 o'clock and 3:00 o'clock positions to help reduce the risk of personal injury if the driver's airbag inflates.

- Never hold the steering wheel at the 12 o'clock position or with your hands anywhere inside the steering wheel or on the steering wheel hub. Holding the steering wheel the wrong way increases the risk of severe injury to the arms, hands, and head if the driver airbag deploys.

### WARNING

- Objects between you and the airbag will increase the risk of injury in a crash by interfering with the way the airbag unfolds and/or by being pushed into you as the airbag inflates.
- Always make sure nothing is in the front airbag deployment zone that could be struck by the airbag when it inflates.
  - Objects in the zone of a deploying airbag can become projectiles when the airbag deploys and cause serious personal injury.
  - Never hold things in your hands or on your lap when the vehicle is in use.
  - Never place accessories or other objects (such as cup holders, telephone brackets, note pads, navigation systems, or things that are large, heavy, or bulky) on the doors; never attach them to the doors or the windshield; never place them over or near or attach them to the area marked „AIRBAG“ on the steering wheel, instrument panel or the seat backrests; never place them between these areas and you or any other person in the vehicle.
  - Never attach objects to the windshield above the passenger front airbag, such as accessory GPS navigation units or music players. Such objects could cause serious injury in a collision, especially when the airbags inflate.
  - Never recline the front passenger seat to transport objects. Items can also move into the deployment area of the side airbags or the front airbag during braking or in a sudden maneuver. Objects near the airbags can fly dangerously through the passenger compartment and cause injury, particularly when the seat is reclined and the airbags inflate.

### WARNING

- A person on the front passenger seat, especially infants and small children, will receive serious injuries and can even be killed by being too close to the airbag when it inflates.
- Although the Advanced Airbag System in your vehicle is designed to turn off the front passenger airbag if an infant or a small child is on the front passenger seat, nobody can absolutely guarantee that deployment under these special conditions is impossible in all conceivable situations that may happen during the useful life of your vehicle.
  - The Advanced Airbag System can deploy in accordance with the „low risk“ option for 3- and 6-year-old children under the U.S. Federal Standard if a child with electrical capacitance greater than the combined capacitance of a typical one-year old infant restrained in one of the forward facing or rearward-facing child seats with which your vehicle was certified is on the front passenger seat and the other conditions for airbag deployment are met.
  - Accident statistics have shown that children are generally safer in the rear seat area than in the front seating position.
  - For their own safety, all children, especially 12 years and younger, should always ride in the back properly restrained for their age and size.

### Advanced front airbag system

Your vehicle is equipped with a front Advanced Airbag System in compliance with United States Federal Motor Vehicle Safety Standard (FMVSS) 208, as well as Canada Motor Vehicle Safety Standard (CMVSS) 208 as applicable at the time your vehicle was manufactured.

The front Advanced Airbag System supplements the safety belts to provide additional protection for the driver's and front passenger's heads and upper bodies in frontal crashes. The airbags inflate only in frontal impacts when the vehicle deceleration is high enough. ►

The front Advanced Airbag System for the front seat occupants is not a substitute for your safety belts. Rather, it is part of the overall occupant restraint system in your vehicle. Always remember that the airbag system can only help to protect you, if you are sitting upright, wearing your safety belt and wearing it properly. This is why you and your passengers must always be properly restrained, not just because the law requires you to be.



The Advanced Airbag System in your vehicle has been certified to meet the “low risk” requirements for 3 and 6 year-old children on the passenger side and very small adults on the driver side. The low risk deployment criteria are intended to help reduce the risk of injury through interaction with the front airbag that can occur, for example, by being too close to the steering wheel and instrument panel when the airbag inflates.

In addition, the system has been certified to comply with the “suppression” requirements of the Safety Standard, to turn off the front airbag for infants 12 months old and younger who are restrained on the front passenger seat in child restraints that are listed in the Standard ⇒ *page 293, Child restraints and Advanced Airbags*.

“Suppression” requires the front airbag on the passenger side to be turned off if:

- a child up to about one year of age is restrained on the front passenger seat in one of the rear-facing or forward-facing infant restraints listed in Federal Motor Vehicle Safety Standard 208 with which the Advanced Airbag System in your vehicle was certified. For a listing of the child restraints that were used to certify your vehicle's compliance with the US Safety Standard ⇒ *page 293*,
- When a person is detected on the front passenger seat that has an electrical capacitance that is more than the total electrical capacitance of a child that is about 1 year old restrained in one of the rear-facing or forward-facing infant restraints (listed in Federal Motor Vehicle Safety Standard 208 with which the Advanced Airbag System in your vehicle was certified), the front

airbag on the passenger side may or may not deploy.

The **PASSENGER AIR BAG OFF**  light comes on when the electronic control unit detects a total electrical capacitance on the front passenger seat that requires the front airbag to be turned off. If the **PASSENGER AIR BAG OFF**  light does not come on, the front airbag on the passenger side has not been turned off by the control unit and can deploy if the control unit senses an impact that meets the conditions stored in its memory.

If the total electrical capacitance registered on the front passenger seat is more than that of a typical 1 year-old, but less than the weight of a small adult, the front airbag on the passenger side may deploy (the **PASSENGER AIR BAG OFF**  light does not come on).

**For example, the airbag may deploy if:**

- a small child that is heavier than a typical 1 year-old child is on the front passenger seat (regardless of whether the child is in one of the child safety seats listed ⇒ *page 293*),
- a child who has outgrown child restraints is on the front passenger seat.

If the front passenger airbag is turned off, the **PASSENGER AIR BAG OFF**  light in the headliner will come on and stay on.

If the front passenger airbag deploys, the Federal Standard requires the airbag to meet the “low risk” deployment criteria to help reduce the risk of injury through interaction with the airbag. “Low risk” deployment occurs in those crashes that take place at lower decelerations as defined in the electronic control unit. ⇒ *page 281*

**Always remember:** Even though your vehicle is equipped with Advanced Airbags, the safest place for children is properly restrained on the back seat. Please be sure to read the important information in the sections that follow and be sure to heed all of the WARNINGS.



#### WARNING

To reduce the risk of injury when an airbag inflates, always wear safety belts properly. ►

- If you are unrestrained, leaning forward, sitting sideways or out of position in any way, your risk of injury is much higher.
- You will also receive serious injuries and could even be killed if you are up against the airbag or too close to it when it inflates - even with an Advanced Airbag ⇒ *page 269*.

### **WARNING**

A child in a rearward-facing child safety seat installed on the front passenger seat will be seriously injured and can be killed if the front airbag inflates - even with an Advanced Airbag System.

- Although the Advanced Airbag System in your vehicle is designed to turn off the front airbag when a rearward-facing child restraint has been installed on the front passenger seat, nobody can absolutely guarantee that deployment is impossible in all conceivable situations that may happen during the useful life of your vehicle.
- The inflating airbag will hit the child safety seat or infant carrier with great force and will smash the child safety seat and child against the backrest, center armrest, door, or roof.
- Always install rearward-facing child restraints on the rear seat.
- If you must install a rearward facing child safety seat on the front passenger seat because of exceptional circumstances and the **PASSENGER AIR BAG OFF**  light does not come on and stay on, immediately install the rear-facing child safety seat in a rear seating position and have the airbag system inspected by your authorized Audi dealer.

### **WARNING**

If, in exceptional circumstances, you must install a forward-facing child restraint on the front passenger's seat:

- Always make sure the forward-facing seat has been designed and certified by its manufacturer for use on a front seat with a passenger front and side airbag.



- Never put the forward-facing child restraint up against or very near the instrument panel.
- Always move the front passenger seat to the highest position in the up and down adjustment range and move it back to the rearmost position in the seat's fore and aft adjustment range, as far away from the airbag as possible, before installing the forward-facing child restraint.
- Always make sure that the safety belt upper anchorage is behind the child restraint and not next to or in front of the child restraint so that the safety belt will be properly positioned.
- Always make sure that there is nothing on the front passenger seat that will cause the capacitive passenger detection system in the seat to signal to the Airbag System that the seat is occupied by a person when it is not, or to signal that it is occupied by someone who is heavier than the person actually sitting on the seat. The presence of additional objects could cause the passenger front airbag to be turned on when it should be off, or could cause the airbag to work in a way that is different from the way it would have worked without the object on the seat.
- Make sure that the **PASSENGER AIR BAG OFF**  light comes on and stays on all the time whenever the ignition is switched on.

### **Advanced Airbag System components**

The front passenger seat in your vehicle has a lot of very important parts of the Advanced Airbag System in it. These parts include the capacitive passenger detection system, wiring, brackets, and more. The control unit monitors the system on the front passenger seat when the ignition is switched on and turns the airbag indicator light on when a malfunction in the one of the system components is detected ⇒ *page 281*. Because the front passenger seat contains important parts of the Advanced Airbag System, you must take care to prevent it from being damaged. Damage to the seat may prevent the Advanced

Airbag System for the front passenger seat from doing its job in a crash.



**The front Advanced Airbag System consists of the following:**

- Crash sensors in the front of the vehicle that measure vehicle acceleration/deceleration to provide information to the Advanced Airbag System about the severity of the crash.
- An electronic control unit, with integrated crash sensors for front and side impacts. The control unit “decides” whether to fire the front airbags based on the information received from the crash sensors. The control unit also “decides” whether the safety belt pretensioners should be activated.
- An Advanced Airbag with gas generator and control valve for the driver inside the steering wheel hub.
- An Advanced Airbag with gas generator and control valve inside the instrument panel for the front passenger.
- A capacitive passenger detection system underneath the front passenger seat cover. This system measures the electrical capacitance of the person in the seat. The information registered is sent continuously to the electronic control unit to regulate deployment of the front Advanced Airbag on the passenger side.
- An airbag monitoring system and indicator light  in the instrument cluster.
- A sensor in each front seat registers the distance between the respective seat and the steering wheel or instrument panel. The information registered is sent continuously to the electronic control unit to regulate deployment of the front Advanced Airbags.
- The **PASSENGER AIR BAG OFF**  **ON**  light comes on in the headliner ⇒ *page 281, fig. 236* and tells you the status of the Advanced Airbag on the passenger side.
- A sensor in the safety belt latch for the driver and for the front seat passenger that senses whether that safety belt is latched or not and transmits this information to the electronic control unit.

 **WARNING**



- Damage to the front passenger seat can prevent the front airbag from working properly.
- Improper repair or disassembly of the front passenger and driver seat will prevent the Advanced Airbag System from functioning properly.
  - Repairs to the front passenger seat must be performed by qualified and properly trained workshop personnel.
  - Never remove the front passenger or driver seat from the vehicle.
  - Never remove the upholstery from the front passenger seat.
  - Never disassemble or remove parts from the seat or disconnect wires from it.
  - Never carry sharp objects in your pockets or put them on the seat. The capacitive passenger detection mat in the front passenger seat will not function properly if it is punctured.
  - Never carry things on your lap or carry objects on the front passenger seat. Such objects can influence the capacitance registered by the capacitive passenger detection system, so that incorrect information is provided to the airbag control unit.
  - Never store items under the front passenger seat. Parts of the Advanced Airbag System under the passenger seat could be damaged, preventing them and the airbag system from working properly.
  - Never place seat covers or replacement upholstery that have not been specifically approved by Audi on the front seats.
  - Seat covers can prevent the Advanced Airbag System from recognizing child restraints or occupants on the front passenger seat and prevent the side airbag in the seat backrest from deploying properly.
  - If a seat heater has been retrofitted or otherwise added to the front passenger seat, never install any child restraint system on this seat.
  - Never use cushions, pillows, blankets, or similar items on the front passenger seat.

The additional layers prevent the capacitive passenger detection system from accurately measuring the capacitance of the child safety seat and/or the person on the seat and thus keep the Advanced Airbag System from working properly.

- Never place or use any electrical device (such as a laptop, CD player, electronic games device, power inverter or seat heater for child seats) on the front passenger seat if the device is connected to the 12-volt socket or the cigarette lighter socket. Such devices can influence the capacitance registered by the capacitive passenger detection system, so that incorrect information is provided to the airbag control unit.
- If you must use a child restraint on the front passenger seat and the child restraint manufacturer's instructions require the use of a towel, foam cushion or something else to properly position the child restraint, make certain that the **PASSENGER AIR BAG OFF**  light comes on and stays on whenever the child restraint is installed on the front passenger seat.
- If the **PASSENGER AIR BAG OFF**  light does not come on and stay on, immediately install child restraint in a rear seating position and have the airbag system inspected by your Audi dealer.

### **WARNING**

If the front passenger seat gets wet, dry it immediately.

- If liquid soaks into the front passenger seat, this can keep the airbag system from working properly and may, for instance, deactivate the passenger frontal airbag. If this happens, the **PASSENGER AIR BAG OFF**  light will come on and stay on together with the airbag indicator light  in the instrument cluster.
- If liquid is pooled on the seat, but has not soaked in, this may also keep the airbag system from working properly and cause the passenger frontal airbag to be enabled (turned on), even though there is a properly

installed child restraint system on the seat. Wet towels or other wet things on the seat cushion can have the same effect. If the front passenger frontal airbag is turned on, the **PASSENGER AIR BAG OFF**  light will turn off.

### **How the Advanced Airbag System components work together**

The front Advanced Airbag System and the side airbags supplement the protection offered by the front three-point safety belts and the adjustable head restraints to help reduce the risk of injury in a wide range of accident and crash situations. Be sure to read the important information about safety and heed the WARNINGS in this chapter.

Deployment of the Advanced Airbag System and the activation of the safety belt pretensioners depend on the deceleration measured by the crash sensors and registered by the electronic control unit. Crash severity depends on speed and deceleration as well as the mass and stiffness of the vehicle or object involved in the crash.

On the passenger side, regardless of safety belt use, the front passenger frontal airbag will be turned off if the electrical capacitance measured by the capacitive passenger detection system on the front passenger seat is less than the amount programmed in the electronic control unit. The front passenger frontal airbag will also be turned off if the capacitance measured by the system for the front passenger seat equals that of an infant of about one year of age in one of the child seats that was used to certify the Advanced Airbag System under Federal Motor Vehicle Safety Standard 208. The **PASSENGER AIR BAG OFF**  light comes on and stays on to tell you when the front Advanced Airbag System on the passenger side has been turned off ⇒ *page 281*.

### **WARNING**

- To reduce the risk of injury when an airbag inflates, always wear safety belts properly.
- If you are unrestrained, leaning forward, sitting sideways or out of position in any way, your risk of injury is much higher.

- You will also receive serious injuries and could even be killed if you are up against the airbag or too close to it when it inflates - even with an Advanced Airbag ⇒ *page 269*.

### More important things to know about front airbags



Fig. 235 Inflated front airbags

Safety belts are important to help keep front seat occupants in the proper seated position so that airbags can unfold properly and provide supplemental protection in a frontal collision.

The front airbags are designed to provide additional protection for the chest and face of the driver and the front seat passenger when:

- safety belts are worn properly
- the seats have been positioned so that the occupant is properly seated as far as possible from the airbag
- and the head restraints have been properly adjusted

Because airbags inflate in the blink of an eye with great force, things you have on your lap or have placed on the seat could become dangerous projectiles, and be pushed into you if the airbag inflates.

When an airbag deploys, fine dust is released. This is normal and is not caused by a fire in the vehicle. This dust is made up mostly of a powder used to lubricate the airbags as they deploy. It could irritate skin.

It is important to remember that while the supplemental airbag system is designed to reduce the likelihood of serious injuries, other injuries, for example swelling, bruising and minor abra-

sions, can also happen when airbags inflate. Airbags do not protect the arms or the lower parts of the body. Front airbags supplement the three-point safety belts only in some frontal collisions in which the vehicle deceleration is high enough to deploy the airbags.

#### Front airbags will not deploy:

- if the ignition is switched off when a crash occurs
- in side collisions
- in rear-end collisions
- in rollovers
- when the crash deceleration measured by the airbag system is less than the minimum threshold needed for airbag deployment as registered by the electronic control unit

#### The front passenger airbag also will not deploy:

- when the front passenger seat is not occupied,
- when the electrical capacitance measured by the capacitive passenger detection system for the front passenger seat indicates that the passenger side frontal airbag must be switched off by the electronic control unit (the **PASSENGER AIR BAG OFF**  light ⇒ *page 281* comes on and stays on).

#### WARNING

Sitting in the wrong position can increase the risk of serious injury in crashes.

- To reduce the risk of injury when the airbags inflate, the driver and passengers must always sit in an upright position, must not lean against or place any part of their body too close to the area where the airbags are located.
- Occupants who are unbelted, out of position or too close to the airbag can be seriously injured by an airbag as it unfolds with great force in the blink of an eye ⇒ *page 270*.

#### WARNING

A child in a rearward-facing child safety seat installed on the front passenger seat will be seriously injured and can be killed if the front

airbag inflates - even with an Advanced Airbag System.

- The inflating airbag will hit the child safety seat or infant carrier with great force and will smash the child safety seat and child against the backrest, center armrest, door or roof.
- Always install rear-facing child safety seats on the rear seat.
- If you must install a rearward-facing child safety seat on the front passenger seat because of exceptional circumstances and the **PASSENGER AIR BAG OFF**  light does not come on and stay on, immediately install the rear-facing child safety seat in a rear seating position and have the airbag system inspected by your authorized Audi dealer.

### **WARNING**

Objects between you and the airbag will increase the risk of injury in a crash by interfering with the way the airbag unfolds or by being pushed into you as the airbag inflates.

- Never hold things in your hands or on your lap when the vehicle is in use.
- Never transport items on or in the area of the front passenger seat. Objects could move into the area of the front airbags during braking or other sudden maneuvers and become dangerous projectiles that can cause serious personal injury if the airbags inflate.
- Never place or attach accessories or other objects (such as cupholders, telephone brackets, large, heavy or bulky objects) on the doors, over or near the area marked “AIRBAG” on the steering wheel, instrument panel, seat backrests or between those areas and yourself. These objects could cause injury in a crash, especially when the airbags inflate.
- Never recline the front passenger's seat to transport objects. Items can also move into the area of the side airbag or the front airbag during braking or in a sudden maneuver. Objects near the airbags can become

projectiles and cause injury, particularly when the seat is reclined.

- Never place or transport objects on the front passenger seat. Objects on the front passenger seat could cause the capacitive sensor in the seat to signal to airbag system that the seat is occupied by a person when it in fact is not, or that the person on the seat is heavier than he or she actually is. The change in electric capacitance because of such objects can cause the passenger front airbag to be turned on when it should be off, or can cause the airbag to work in a way that is different from the way it would have worked without objects on the seat.
- Always make sure that there is nothing on the front passenger seat that will cause the capacitive passenger detection system in the seat to signal to the Airbag System that the seat is occupied by a person when it is not, or to signal that it is occupied by someone who is heavier than the person actually sitting on the seat. The presence of an object could cause the passenger front airbag to be turned on when it should be off, or could cause the airbag to work in a way that is different from the way it would have worked without the object on the seat.



### **WARNING**

The fine dust created when airbags deploy can cause breathing problems for people with a history of asthma or other breathing conditions.

- To reduce the risk of breathing problems, those with asthma or other respiratory conditions should get fresh air right away by getting out of the vehicle or opening windows or doors.
- If you are in a collision in which airbags deploy, wash your hands and face with mild soap and water before eating.
- Be careful not to get the dust into your eyes, or into any cuts or scratches.
- If the residue should get into your eyes, flush them with water.

## Monitoring the Advanced Airbag System

### Airbag monitoring indicator light

Two separate indicators monitor the function of the Advanced Airbag System: the  light and the **PASSENGER AIR BAG OFF**  **ON**  light.

The Advanced Airbag System as well as the side airbags and side curtain airbags with ejection mitigation features (including the electronic control unit, sensors and system wiring) are all monitored continuously to make sure that they are functioning properly whenever the ignition is on. Every time you turn on the ignition, the airbag system indicator light  will come on for a few seconds (function check).

### The system must be inspected when the indicator light :

- does not come on when the ignition is switched on
- does not go out a few seconds after you have switched on the ignition, or
- comes on while driving

If an airbag system malfunction is detected, the indicator light will come on to serve as a constant reminder to have the system inspected immediately.

If a malfunction occurs that turns the front airbag on the passenger side off, the **PASSENGER AIR BAG OFF**  light will come on and stay on whenever the ignition is on.



### WARNING



An airbag system that is not functioning properly cannot provide supplemental protection in a frontal crash.







- If the airbag indicator light  $\Rightarrow$  page 26 comes when the vehicle is being used, have the system inspected immediately by your authorized Audi dealer. It is possible that the airbag will inflate when it is not supposed to, or will not inflate when it should.

### PASSENGER AIR BAG OFF ON light





Fig. 236 Section from the headliner: PASSENGER AIR BAG OFF  ON  light



The **PASSENGER AIR BAG OFF**  **ON**  light is located in the headliner  $\Rightarrow$  fig. 236.

The **PASSENGER AIR BAG OFF**  light will come on and stay on to tell you when the front Advanced Airbag on the passenger side has been turned off by the electronic control unit. If the bulb for the **PASSENGER AIR BAG OFF**  **ON**  light burns out, the airbag indicator light  will come on to signal a malfunction in the Advanced Airbag System. Although the burned-out bulb will not change the way the front passenger's frontal airbag works, it will no longer be possible to use the **PASSENGER AIR BAG OFF**  **ON**  light to make sure that the airbag on/off status is correct for the occupant on the front passenger seat. Have the airbag system inspected immediately by your authorized Audi dealer.

### The **PASSENGER AIR BAG OFF** **ON** light will blink for about 5 seconds when:

- the capacitive passenger detection system, which switches the front seat passenger's frontal Advanced Airbag on and off, detects a change in the status of the front passenger seat.

As soon as the **PASSENGER AIR BAG OFF**  **ON**  light stops blinking, always make sure that the airbag status (on or off) as shown by the light is proper for the age, size and electrical capacitance of the person occupying the front passenger seat. Always make sure that the safety belt for the front passenger seat is properly fastened.

The **PASSENGER AIR BAG OFF**  / **PASSENGER AIR BAG ON**  light will show the status of the  $\blacktriangleright$



### front seat passenger's frontal Advanced Airbag. The PASSENGER AIR BAG OFF light:

- will come on if the front passenger seat is not occupied;
- will come on if the electrical capacitance measured by the capacitive passenger detection system for the front passenger seat equals the combined capacitance of an infant up to about one year of age and one of the rearward-facing or forward-facing child restraints listed in Federal Motor Vehicle Safety Standard 208 with which the Advanced Airbag System in your vehicle was certified; For a listing of the child restraints that were used to certify your vehicle's compliance with the U.S. Safety Standard ⇒ *page 293*.
- will go out if the front passenger seat is occupied by an adult as registered by the capacitive passenger detection system.
- The **PASSENGER AIR BAG OFF**  light must come on and stay on if the ignition is on and...
  - a car bed has been installed on the front passenger seat, or
  - a rearward-facing child restraint has been installed on the front passenger seat, or
  - a forward-facing child restraint has been installed on the front passenger seat,
  - and if the electrical capacitance registered on the front passenger seat is equal to or less than the combined capacitance of a typical 1 year-old infant and one of the rearward-facing or forward-facing child restraints listed in Federal Motor Vehicle Safety Standard 208 with which the Advanced Airbag System in your vehicle was certified.

If the front passenger seat is not occupied, the front airbag will not deploy, and the **PASSENGER AIR BAG OFF**  light will stay on.

Never install a rearward-facing child restraint on the front passenger seat, the safest place for a child in any kind of child restraint is at one of the seating positions on the rear seat ⇒ *page 270*, *Child restraints on the front seat – some important things to know* and ⇒ *page 291*, *Child safety*.

### If the PASSENGER AIR BAG OFF light comes on ...

If the **PASSENGER AIR BAG OFF**  light comes on when one of the conditions listed above is met, be sure to check the light regularly to make certain that the **PASSENGER AIR BAG OFF**  light stays on continuously whenever the ignition is on. If the **PASSENGER AIR BAG OFF**  light does not appear on and does not stay on all the time, stop as soon as it is safe to do so and

- reactivate the system by turning the ignition off for more than 4 seconds and then turning it on again;
- remove and reinstall the child restraint. Make sure that the child restraint is properly installed and that the safety belt for the front passenger seat has been correctly routed through the child restraint as described in the child restraint manufacturer's instructions;
- make sure that the convertible locking retractor on the safety belt for the front passenger seat has been activated and that the safety belt has been pulled tight.
- make sure that no electrical device (such as a laptop, CD player, electronic games device, power inverter or seat heater for child seats) is placed or used on the front passenger seat if the device is connected to the 12-volt socket or the cigarette lighter socket;
- make sure that no seat heater has been retrofitted or otherwise added to the front passenger seat;
- make sure that nothing can interfere with the safety belt buckles and that they are not obstructed;
- make sure that there are no wet objects (such as a wet towel) and no water or other liquids on the front passenger seat cushion.

### If the PASSENGER AIR BAG OFF light still does not come on ...



If the **PASSENGER AIR BAG OFF**  light still does not come on and does not stay on continuously (when the ignition is switched on),

- take the child restraint off the front passenger seat and install it properly at one of the rear ▶

seat positions. Have the airbag system inspected by your Audi dealer immediately.

- move the child to a rear seat position and make sure that the child is properly restrained in a child restraint that is appropriate for its size and age.



### The PASSENGER AIR BAG OFF light should NOT come on ...

The PASSENGER AIR BAG OFF  light should NOT come on when the ignition is on and an adult is sitting in a proper seating position on the front passenger seat. If the PASSENGER AIR BAG OFF  light comes on and stays on while driving, under these circumstances, make sure that:

- the adult on the front passenger seat is properly seated on the center of the seat cushion with his or her back up against the backrest and the backrest is not reclined,
- the adult is not taking weight off the seat by holding on to the passenger assist handle above the front passenger door or supporting their weight on the armrest,
- the safety belt is being properly worn and that there is not a lot of slack in the safety belt webbing,
- there are no aftermarket seat covers or cushions or other things (such as blankets) on the front passenger seat that might cause the capacitive passenger detection system to miscalculate electrical capacitance.

### Important safety instructions on monitoring the Advanced Airbag System

#### WARNING

- If the status of the Advanced Airbag System has changed while the vehicle is moving, the PASSENGER AIR BAG OFF  ON  light blinks for about 5 seconds to catch the driver's attention. If this happens, always stop as soon as it is safe to do so and check the steps described above.
- If the PASSENGER AIR BAG OFF  light does not go off when an adult who is not very small is sitting on the front passenger

seat after taking the steps described above, make sure the adult is properly seated and restrained at one of the rear seating positions. Have the airbag system inspected by your authorized Audi dealer before transporting anyone on the front passenger seat.

#### WARNING

An airbag system that is not functioning properly cannot provide supplemental protection in a frontal crash.

- If the airbag indicator light  *page 26* comes when the vehicle is being used, have the system inspected immediately by your authorized Audi dealer. It is possible that the airbag will inflate when it is not supposed to, or will not inflate when it should.

#### WARNING

If the front airbag inflates, a child without a child restraint, or in a rearward-facing child safety seat, or in a forward-facing child restraint that has not been properly installed will be seriously injured and can be killed.

- Even though your vehicle is equipped with an Advanced Airbag System, make certain that all children, especially 12 years and younger, always ride on the back seat properly restrained for their age and size.
- Always install forward or rear-facing child safety seats on the rear seat – even with an Advanced Airbag System.
- If you must install a rearward-facing child safety seat on the front passenger seat because of exceptional circumstances and the PASSENGER AIR BAG OFF  light does not appear and stay on, immediately install the rear-facing child safety seat in a rear seating position and have the airbag system inspected by your authorized Audi dealer.
- If, in exceptional circumstances, you must install a forward-facing child restraint on the front passenger seat, always move the seat into its rearmost position in the seat's fore and aft adjustment range, as far away from the airbag as possible. The backrest must be adjusted to an upright position. ►

Make sure that the **PASSENGER AIR BAG OFF**  light comes on and stays on all the time whenever the ignition is switched on.

### **WARNING**

- If the **PASSENGER AIR BAG OFF**  light does not go out when an adult is sitting on the front passenger seat after taking the steps described above, make sure the adult is properly seated and restrained at one of the rear seating positions.
- Have the airbag system inspected by your authorized Audi dealer before transporting anyone on the front passenger seat.

### **Tips**

If the capacitive passenger detection system determines that the front passenger seat is empty, the frontal airbag on the passenger side will be turned off, and the **PASSENGER AIR BAG OFF**  light will stay on.

### **Repair, care and disposal of the airbags**

Parts of the airbag system are installed at many different places on your Audi. Installing, removing, servicing or repairing a part in an area of the vehicle can damage a part of an airbag system and prevent that system from working properly in a collision.

There are some important things you have to know to make sure that the effectiveness of the system will not be impaired and that discarded components do not cause injury or pollute the environment.

### **WARNING**

Improper care, servicing and repair procedures can increase the risk of personal injury and death by preventing an airbag from deploying when needed or deploying an airbag unexpectedly:

- Never cover, obstruct, or change the steering wheel horn pad or airbag cover or the instrument panel or modify them in any way.

- Never attach any objects such as cupholders or telephone mountings to the surfaces covering the airbag units.
- For cleaning the horn pad or instrument panel, use only a soft, dry cloth or one moistened with plain water. Solvents or cleaners could damage the airbag cover or change the stiffness or strength of the material so that the airbag cannot deploy and protect properly.
- Never repair, adjust, or change any parts of the airbag system.
- All work on the steering wheel, instrument panel, front seats or electrical system (including the installation of audio equipment, cellular telephones and CB radios, etc.) must be performed by a qualified technician who has the training and special equipment necessary.
- For any work on the airbag system, we strongly recommend that you see your authorized Audi dealer or qualified workshop.
- Never modify the front bumper or parts of the vehicle body.
- Always make sure that the side airbag can inflate without interference:
  - Never install seat covers or replacement upholstery over the front seatbacks that have not been specifically approved by Audi.
  - Never use additional seat cushions that cover the areas where the side airbags inflate.
  - Damage to the original seat covers or to the seam in the area of the side airbag module must always be repaired immediately by an authorized Audi dealer.
- The airbag system can deploy only once. After an airbag has been deployed, it must be replaced with new replacement parts designed and approved especially for your Audi model version. Replacement of complete airbag systems or airbag components must be performed by qualified workshops only. Make sure that any airbag service action is entered in your Audi Warranty & Maintenance booklet under **AIRBAG REPLACEMENT RECORD**.

- For safety reasons in severe accidents, the alternator and starter are separated from the vehicle battery with a pyrotechnic circuit interrupter.
- Work on the pyrotechnic circuit interrupter must only be performed by a qualified technicians who have the experience, information and special tools necessary to perform the work safely.
- If the vehicle or the circuit interrupter is scrapped, all applicable safety precautions must be followed.



### For the sake of the environment

Undeployed airbag modules and pretensioners might be classified as Perchlorate Material - special handling may apply, see [www.dtsc.ca.gov/hazardouswaste/perchlorate](http://www.dtsc.ca.gov/hazardouswaste/perchlorate). When the vehicle or parts of the restraint system including airbag modules and safety belts with pretensioners are scrapped, all applicable laws and regulations must be observed. Your authorized Audi dealer is familiar with these requirements and we recommend that you have your dealer perform this service for you.

### Other things that can affect Advanced Airbag performance

Changing the vehicle's suspension system can change the way that the Advanced Airbag System performs in a crash. For example, using tire-rim combinations not approved by Audi, lowering the vehicle, changing the stiffness of the suspension, including the springs, suspension struts, shock absorbers etc. can change the forces that are measured by the airbag sensors and sent to the electronic control unit. Some suspension changes can, for example, increase the force levels measured by the sensors and make the airbag system deploy in crashes in which it would not deploy if the changes had not been made. Other kinds of changes may reduce the force levels measured by the sensors and prevent the airbag from deploying when it should.



### WARNING

Changing the vehicle's suspension including use of unapproved tire-rim combinations can change Advanced Airbag performance and increase the risk of serious personal injury in a crash.

- Never install suspension components that do not have the same performance characteristics as the components originally installed on your vehicle.
- Never use tire-rim combinations that have not been approved by Audi.

## Side airbags

### Description of side airbags

*The airbag system can provide supplemental protection to properly restrained occupants.*



Fig. 237 Side airbag location in the driver's seat

The side airbags are located in the sides of the front seat backrests ⇒ *fig. 237* and the rear backrest\* facing the doors.

The side airbags installed for the front seating positions have been designed and certified to help reduce the risk of injury that can be caused by airbags when they inflate, particularly when the occupant sitting next to it is not seated properly. The side airbag for the front passenger seat can be used with properly installed child restraints. Please be sure to read the important information and warnings whenever using a child restraint in a vehicle: Safety belts ⇒ *page 261*, Airbag system ⇒ *page 269*, Child safety ⇒ *page 291*.

**The side airbag system basically consists of:** ►

- the electronic control module and external side impact sensors
- the two side airbags located in the sides of the front backrests
- two rear side airbags\*
- the airbag warning light in the instrument cluster.

The airbag system is monitored electronically to make certain that it is functioning properly at all times. Each time you turn on the ignition, the airbag system indicator light will come on for a few seconds (self diagnostics).

The side airbag system supplements the safety belts and can help to reduce the risk of injury to the driver's, front and rear\* passenger's upper torso on the side of the vehicle that is struck in a side collision. The airbag deploys only in side impacts and only when the vehicle acceleration registered by the control unit is high enough. If this rate is below the reference value programmed into the control unit, the side airbags will not be triggered, even though the car may be badly damaged as a result of the collision. It is not possible to define an airbag triggering range that will cover every possible angle of impact, since the circumstances will vary considerably between one collision and another. Important factors include, for example, the nature (hard or soft) of the impacting object, the angle of impact, vehicle speed, etc. ⇒ *page 287, Important safety instructions on the side airbag system.*

Aside from their normal safety function, safety belts work to help keep the driver or front passenger in position in the event of a side collision so that the side airbags can provide protection.

The airbag system is *not* a substitute for your safety belt. Rather, it is part of the overall occupant restraint system in your vehicle. Always remember that the side airbag system can only help to protect you if you are wearing your safety belt and wearing it properly. This is another reason why you should always wear your safety belts, not just because the law requires you to do so ⇒ *page 261, General information.*

It is important to remember that while the supplemental side airbag system is designed to re-

duce the likelihood of serious injuries, other injuries, for example, swelling, bruising, friction burns and minor abrasions can also be associated with deployed side airbags. Remember too, side airbags will deploy only once and only in certain kinds of accidents - your safety belts are always there to offer protection.

Vehicle damage, repair costs or even the lack of vehicle damage are not necessarily an indication of over-sensitive or failed airbag activation. In some collisions, both front and side airbags may inflate. Remember too, that airbags will deploy only once and only in certain kinds of collisions - your safety belts are always there to offer protection in those accidents in which airbags are not supposed to deploy or when they have already deployed.

### **The side airbag system will not deploy:**

- when the ignition is turned off
- in side collisions when the acceleration measured by the sensor is too low
- in front-end collisions
- in rear-end collisions
- in rollovers.

In some types of accidents the front airbags, side curtain airbags and side airbags may be triggered together.



### **WARNING**

- Safety belts and the airbag system will only provide protection when occupants are in the proper seating position ⇒ *page 287.*
- If the airbag indicator light ⇒ *page 26* comes when the vehicle is being used, have the system inspected immediately by your authorized Audi dealer. It is possible that the airbag will inflate when it is not supposed to, or will not inflate when it should.

### How supplemental side airbags work

Side airbags deploy instantly and can help reduce the risk of upper torso injuries for occupants who are properly restrained.

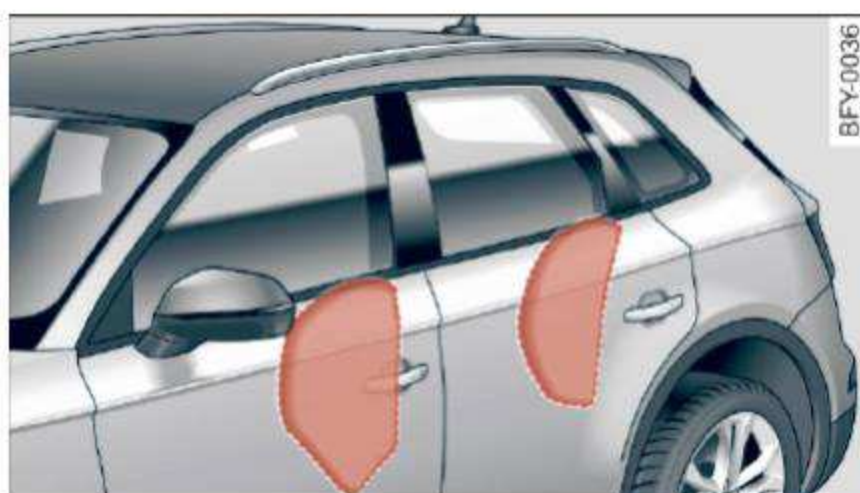

**Fig. 238** Inflated side airbags on left side of vehicle, rear side airbag optional equipment

When the system is triggered, the airbag is filled with propellant gas and breaks through a seam in the seat surface area. It expands between the side trim panel and the passenger. In order to help provide this additional protection, the side airbag must inflate within a fraction of a second at very high speed and with great force. The supplemental side airbag could injure you if your seating position is not proper or upright or if items are located in the area where the supplemental side airbag expands. This applies especially to children ⇒ *page 291, Child safety*. Supplemental side airbags inflate between the occupant and the door panel on the side of the vehicle that is struck in certain side collision ⇒ *fig. 238*.

Although they are not a soft pillow, they can “cushion” the impact and in this way they can help to reduce the risk of injury to the upper part of the body.

A fine dust may develop when the airbag deploys. This is normal and does not mean there is a fire in the vehicle.

### Important safety instructions on the side airbag system

Airbags are only supplemental restraints. Always properly wear safety belts and ride in a proper seating position.

There is a lot that you and your passengers must know and act accordingly to help the safety belts and airbags do their job to provide supplemental protection.

#### WARNING

An inflating side airbag can cause serious or fatal injury. Improperly wearing safety belts and improper seating positions increase the risk of serious personal injury and death whenever a vehicle is being used.

- In order to reduce the risk of injury when the supplemental side airbag inflates:
  - Always sit in an upright position and never lean against the area where the supplemental side airbag is located.
  - Never let a child or anyone else rest their head against the side trim panel in the area where the supplemental side airbag inflates.
  - Always make sure that safety belts are worn correctly,
  - Do not let anyone sitting in the front seat put their hand or any other parts of their body out of the window.
- Always make sure that the side airbag can inflate without interference.
  - Never install seat covers or replacement upholstery over the front seatbacks that have not been specifically approved by Audi.
  - Never use additional seat cushions that cover the areas where the side airbags deploy.
  - Damage to the original seat covers or to the seam in the area of the side airbag module must always be repaired immediately by an authorized Audi dealer.
- Objects between you and the airbag can increase the risk of injury in an accident by interfering with the way the airbag unfolds or

by being pushed into you as the airbag inflates.

- Never place or attach accessories or other objects (such as cupholders, telephone brackets, or even large, bulky objects) on the doors, over or near the area marked “AIRBAG” on the seat backrests.
- Such objects and accessories can become dangerous projectiles and cause injury when the supplemental side airbag deploys.
- Never carry any objects or pets in the deployment space between them and the airbags or allow children or other passengers to travel in this position.
- Always use the built-in coat hooks\* only for lightweight clothing. Never leave any heavy or sharp-edged objects in the pockets that may interfere with side airbag deployment and can cause personal injury in an accident.
- Always prevent the side airbags from being damaged by heavy objects knocking against or hitting the sides of the seatbacks.
- The airbag system can only be triggered once. If the airbag has been triggered, the system must be replaced by an authorized Audi dealership.
- Damage (cracks, deep scratches etc.) to the original seat covers or to the seam in the area of the side airbag module must always be repaired immediately by an authorized Audi dealer.
- If children are seated improperly, their risk of injury increases in the case of an accident ⇒ *page 291, Child safety*.
- Never attempt to modify any components of the airbag system in any way.
- In a side collision, side airbags will not function properly if sensors cannot correctly measure increasing air pressure inside the doors when air escapes through larger, unclosed openings in the door panel.
  - Never drive with interior door trim panels removed.
  - Never drive when parts have been removed from the inside door panel and the openings they leave have not been properly closed.

- Never drive when loudspeakers in the doors have been removed unless the speaker holes have been properly closed.
- Always make certain that openings are covered or filled if additional speakers or other equipment is installed in the inside door panels.
- Always have work on the doors done by an authorized Audi dealer or qualified workshop.

## Side curtain airbags

### Description of side curtain airbags

*The side curtain airbags can provide supplemental protection to properly restrained occupants.*



**Fig. 239** Side curtain airbags, driver's side: location

The side curtain airbags are located on both sides of the interior above the front and rear side windows ⇒ *fig. 239*.

The side curtain airbags contain features that provide ejection mitigation to help prevent vehicle occupants or parts of their bodies from being completely or partially ejected from the vehicle interior in certain side impacts and vehicle roll-overs.

The side curtain airbag system supplements the safety belts and can help to reduce the risk of injury for occupants' heads and upper torso in a side collision. The side curtain airbag inflates in side impacts and only when the vehicle acceleration registered by the control unit is high enough. If this rate is below the reference value programmed into the control unit, the side curtain airbag will not be triggered, even though the car may be badly damaged as a result of the

collision. It is not possible to define an airbag triggering range that will cover every possible angle of impact, since the circumstances will vary considerably between one collision and another. Important factors include, for example, the nature (hard or soft) of the impacting object, the angle of impact, vehicle speed, etc. ⇒ *page 289, How side curtain airbags work.*

Aside from their normal safety function, safety belts work to help keep the driver or front passenger in position in the event of a collision so that the side curtain airbags can provide protection.

The airbag system is not a substitute for your safety belt. Rather, it is part of the overall occupant restraint system in your vehicle. Always remember that the airbag system can only help to protect you if you are wearing your safety belt and wearing it properly. This is another reason why you should always wear your safety belts, not just because the law requires you to do so ⇒ *page 261, General information.*

It is important to remember that while the side curtain airbag system is designed to help reduce the likelihood of serious injuries, other injuries, for example, swelling, bruising, friction burns and minor abrasions can also be associated with these airbags upon deployment. Remember too, these airbags will deploy only once and only in certain kinds of accidents - your safety belts are always there to offer protection.

#### The side curtain airbag system basically consists of:

- The electronic control module and external side impact sensors
- The side curtain airbags above the windows of the outer seating positions with ejection mitigation features
- The airbag indicator light in the instrument panel

The airbag system is monitored electronically to make certain it is functioning properly at all times. Each time you turn on the ignition, the airbag system indicator light will come on for a few seconds (self diagnostics).

#### The side curtain airbag is not activated:

- if the ignition is turned off
- in side collisions when the acceleration measured by the sensor is too low
- in rear-end collisions.

#### WARNING

- Safety belts and the airbag system will only provide protection when occupants are in the proper seating position ⇒ *page 56, Front seats.*
- If the airbag indicator light ⇒ *page 26* comes when the vehicle is being used, have the system inspected immediately by your authorized Audi dealer. It is possible that the airbag will inflate when it is not supposed to, or will not inflate when it should.

#### How side curtain airbags work

Side curtain airbags can work together with side airbags to help reduce the risk of head and upper torso injuries for occupants who are properly restrained.

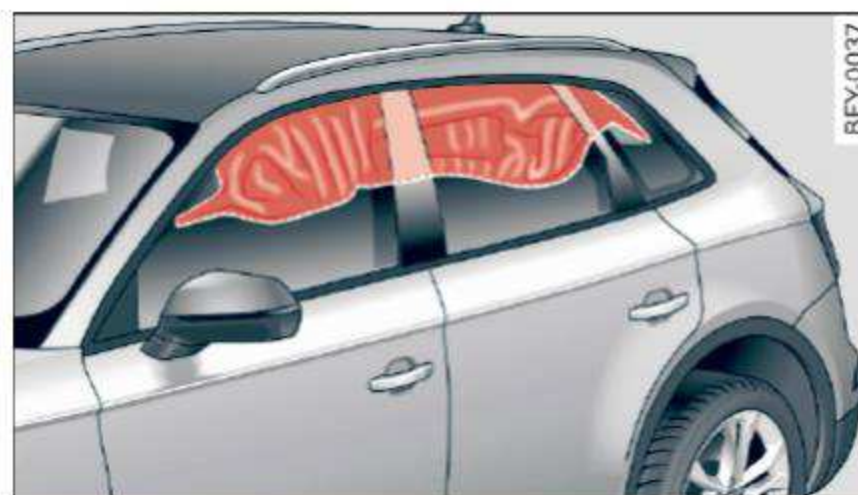

Fig. 240 Illustration of principle: Inflated side curtain airbags on the left side

The side curtain airbags inflate between the occupant and the windows in a side collision ⇒ *fig. 240.*

When the system is triggered, the side curtain airbag is filled with propellant gas and breaks through a seam above the front and rear side windows identified by the AIRBAG label. In order to help provide this additional protection, the side curtain airbag must inflate within the blink of an eye at very high speed and with great force. The side curtain airbag could injure you if your

## Airbag system

seating position is not proper or upright or if items are located in the area where the supplemental side curtain airbag inflates. This applies especially to children ⇒ *page 291*.

Although they are not a soft pillow, side curtain airbags can “cushion” the impact and in this way they can help to reduce the risk of injury to the head and the upper part of the body.

A fine dust may develop when the airbag deploys. This is quite normal and does not mean there is a fire in the vehicle.

### Important safety instructions on the side curtain airbag system

*Airbags are only supplemental restraints. Always properly wear safety belts and ride in a proper seating position.*

There is a lot that you and your passengers must know and do to help the safety belts and airbags do their job to provide supplemental protection.

#### WARNING

Improperly wearing safety belts and improper seating positions increase the risk of serious personal injury and death whenever a vehicle is being used.

- Never let occupants place any parts of their bodies in the area from which the side curtain airbag inflates.
- Always make sure that the side curtain airbags can inflate without interference.
- Use the built-in coat hooks only for light-weight clothing. Never leave any heavy or sharp-edged objects in the pockets that may interfere with airbag deployment and can cause personal injury in a collision.
- Never use hangers to hang clothes on the hooks.
- Only use factory-installed sun shades or, if shades installed after the vehicle leaves the factory, use only genuine Audi sun shades.
- Never swing the sun visors over to the side windows if things such as pens, garage door openers, hands-free speakers, etc. are attached to the sun visors. They could come

loose and cause serious injury if the side curtain airbag inflates.

- A deploying airbag inflates in a fraction of a second and with great force.
- Never attach objects to the cover or in the deployment zone of a side curtain airbag.
- The airbag deployment zones must be kept clear at all times. Make sure there are no objects, pets, or other persons in the space between any vehicle occupant and any airbag at any time.
- Do not attach any accessories to the doors.

#### WARNING

- The airbag system can deploy only once. If the airbag has been triggered, the system must be replaced by an authorized Audi dealer or qualified workshop.
- Always have work involving the side curtain airbag system, removal and installation of the airbag components, or other repairs performed by a qualified dealership. Otherwise the airbag system may not work correctly.
- Never attempt to modify any components of the airbag system in any way.

## Child safety

### Important information

#### Introduction

*The rear seat is generally the safest place in a collision.*

The physical principles of what happens when your vehicle is in a crash apply also to children ⇒ *page 262, What happens to occupants not wearing safety belts?*. But unlike adults and teenagers, their muscles and bones are not fully developed. In many respects children are at greater risk of serious injury in crashes than adults.

Because children's bodies are not fully developed, they require restraint systems especially designed for their size, weight, and body structure. Many countries and all states of the United States and provinces of Canada have laws requiring the use of approved child restraint systems for infants and small children.

In a frontal crash at a speed of 20 – 35 mph (30 – 56 km/h) the forces acting on a 13-pound (6 kg) infant will be more than 20 times the weight of the child. This means the weight of the child would suddenly be more than 260 pounds (120 kg). Under these conditions, only an appropriate child restraint properly used can reduce the risk of serious injury. Child restraints, like adult safety belts, must be used properly to be effective. Used improperly, they can increase the risk of serious injury in an accident.

All children, especially those 12 years and younger must always ride in the back seat properly restrained for their age and size. If you must install a child restraint on the front passenger seat in exceptional circumstances, be sure to read and heed the important information and warnings ⇒ *page 270*. Infants and other children who are properly restrained in an appropriate child restraint that is for their size and age can benefit from the protection that supplemental side airbags provide in some kinds of crashes.

For more information please see information provided by the:

- National Highway Traffic Safety Administration (NHTSA), currently at : <http://www.safercar.gov> (for the USA)
- Transport Canada Information Centre, currently at: <http://www.tc.gc.ca> (for Canada)

Consult the child safety seat manufacturer's instructions in order to be sure the seat is right for your child's size ⇒ *page 295, Important safety instructions for using child safety seats*. Please be sure to read and heed all of the important information and WARNINGS about child safety, Advanced Airbags, and the installation of child restraints in this chapter.

There is a lot you need to know about the Advanced Airbags in your vehicle and how they work when infants and children in child restraints are on the front passenger seat. Because of the large amount of important information, we cannot repeat it all here. We urge you to read the detailed information in this owner's manual about airbags and the Advanced Airbag System in your vehicle and the very important information about transporting children on the front passenger seat. Please be sure to heed the WARNINGS – they are extremely important for your safety and the safety of your passengers, especially infants and small children.



#### WARNING

- Accident statistics have shown that children are generally safer in the rear seat area than in the front seating position. Always restrain any child age 12 and under in the rear.
- All vehicle occupants and especially children must be restrained properly whenever riding in a vehicle. An unrestrained or improperly restrained child could be injured by striking the interior or by being ejected from the vehicle during a sudden maneuver or impact. An unrestrained or improperly restrained child is also at greater risk of injury or death through contact with an inflating airbag.
- A suitable child restraint properly installed and used at one of the rear seating positions provides the highest degree of protection for infants and small children in most accident situations.

### WARNING

Children on the front seat of any car even with Advanced Airbags can be seriously injured or even killed when an airbag inflates. A child in a rearward-facing child safety seat installed on the front passenger seat will be seriously injured and can be killed if the front airbag inflates.

- The inflating airbag will hit the child safety seat or infant carrier with great force and will smash the child safety seat and child against the backrest, center armrest, or door.
- Always install rear-facing child safety seats on the rear seat.
- If you must install a rearward facing child safety seat on the front passenger seat in exceptional circumstances and the **PASSENGER AIR BAG OFF**  light does not come on and stay on, immediately install the rear-facing child safety seat in a rear seating position and have the airbag system inspected immediately by your Audi dealer.

### WARNING

- Forward-facing child seats installed on the front passenger seat may interfere with the deployment of the airbag and cause serious personal injury to the child.
- If exceptional circumstances require the use of a forward-facing child restraint on the front passenger's seat, the child's safety and well-being require the following special precautions to be taken:
  - Always make sure that the forward-facing seat has been designed and certified by its manufacturer for use on a front passenger seat with a front and side airbag.
  - Always carefully follow the manufacturer's instructions provided with the child seat or infant carrier.
  - Never install a child restraint without a properly attached top tether strap if the child restraint manufacturer's instructions require the top tether strap to be used.

- Never put the forward-facing child restraint up against or very near the instrument panel.
- Always set the safety belt upper anchorage to the adjustment position that permits proper installation in accordance with the child restraint manufacturer's instructions.
- Always move the front passenger seat to the highest position in the up and down adjustment range and move it back to the rearmost position in the seat's fore and aft adjustment range, as far away from the airbag as possible, before installing the forward-facing child restraint.
- Always make sure that the safety belt upper anchorage is behind the child restraint and not next to or in front of the child restraint so that the safety belt will be properly positioned.
- Always make sure that nothing prevents the front passenger's seat from being moved to the rearmost position in its fore and aft adjustment range.
- Never place objects on the seat (such as a laptop, CD player, electronic games device, power inverter or seat heater for child seats). These may influence the electrical capacitance measured by the capacitive passenger detection system and can also fly around in an accident and cause serious personal injury.
- Never place or use any electrical device (such as a laptop, CD player, electronic games device, power inverter or seat heater for child seats) on the front passenger seat if the device is connected to the 12-volt socket or the cigarette lighter socket.
- If a seat heater has been retrofitted or otherwise added to the front passenger seat, never install any child restraint system on this seat.
- Make sure that there are no wet objects (such as a wet towel) and no water or other liquids on the front passenger seat cushion.
- Always make sure that the **PASSENGER AIR BAG OFF**  light comes on and stays

on all the time whenever the ignition is switched on.

- If the **PASSENGER AIR BAG OFF**  light does not come on and stay on, immediately install the forward-facing child seat in a rear seating position and have the airbag system inspected by your authorized Audi dealer.
- Always buckle the child seat firmly in place even if a child is not sitting in it. A loose child seat can fly around during a sudden stop or in a collision.
- Always read and heed all WARNINGS whenever using a child restraint in a vehicle ⇒ *page 261, Safety belts*, ⇒ *page 269, Airbag system* and ⇒ *page 291, Important information*.

### Tips

Always replace child restraints that were installed in a vehicle during a crash. Damage to a child restraint that is not visible could cause it to fail in another collision situation.

### Advanced front airbag system and children

Your vehicle is equipped with an “Advanced Airbag System” in compliance with United States Federal Motor Vehicle Safety Standard (FMVSS) 208, as well as Canada Motor Vehicle Safety Standard (CMVSS) 208 as applicable at the time your vehicle was manufactured.

The Advanced Airbag system in your vehicle has been certified to meet the “low-risk” requirements for 3- and 6-year old children on the passenger side and small adults on the driver side. The low risk deployment criteria are intended to reduce the risk of injury through interaction with the airbag that can occur, for example, by being too close to the steering wheel and instrument panel when the airbag inflates. In addition, the system has been certified to comply with the “suppression” requirements of the Safety Standard, to turn off the front airbag for infants up to 12 months who are restrained on the front passenger seat in child restraints that are listed in the Standard.

Even though your vehicle is equipped with an Advanced Airbag system, all children, especially those 12 years and younger, should always ride in the back seat properly restrained for their age and size. The airbag on the passenger side makes the front seat a potentially dangerous place for a child to ride. The front seat is not the safest place for a child in a forward-facing child safety seat. It can be a very dangerous place for an infant or a larger child in a rearward-facing seat.

The vehicle's Advanced Airbag System has a capacitive passenger detection system in the front passenger seat cushion that can detect the presence of a baby or a child in a child restraint system on this seat.

The capacitive passenger detection system registers the changes that result in an electrical field when a child, a child restraint, and a baby blanket are on the front passenger seat. The change in the measured capacitance due to the presence of a child, a child restraint, and a baby blanket on the front passenger seat is related to the child restraint system resting on the seat. The measured capacitance of a child restraint system varies depending on the type of system and specific make and model.

The electrical capacitance of the various types, makes, and models of child restraints specified by the U.S. National Highway Traffic Safety Administration (NHTSA) in the relevant safety standard are stored in the Advanced Airbag System control unit together with the capacitances typical of infants and a 1-year old child. When a child restraint is used on the front passenger seat with a typical 1 year-old infant, the Advanced Airbag System compares the capacitance measured by the capacitive passenger detection system with the data stored in the electronic control unit.

### Child restraints and Advanced Airbags

Regardless of the child restraint that you use, make sure that it has been certified to meet Safety Standards and has been certified by its manufacturer for use with an airbag. Always be sure that the child restraint is properly installed at

one of the rear seating positions. If in exceptional circumstances you must use it on the front passenger seat, carefully read all of the information on child safety and Advanced Airbags and heed all of the applicable WARNINGS. Make certain that the child and child restraint are correctly recognized by the capacitive passenger detection system in the front passenger seat, that the front passenger airbag is turned off, and that the airbag status is always correctly signaled by the **PASSENGER AIR BAG OFF**  light.

Many types and models of child restraints have been available over the years, new models are introduced regularly incorporating new and improved designs and older models are taken out of production. Child restraints are not standardized. Child restraints of the same type typically have different weights and sizes and different “footprints”, the size and shape of the bottom of the child restraint that sits on the seat, when they are installed on a vehicle seat. These differences make it virtually impossible to certify compliance with the requirements for advanced airbags with each and every child restraint that has ever been sold in the past or will be sold over the course of the useful life of your vehicle.

For this reason, the United States National Highway Traffic Safety Administration has published a list of specific type, makes and models of child restraints that must be used to certify compliance of the Advanced Airbag System in your vehicle with the suppression requirements of Federal Motor Vehicle Safety Standard 208. These child restraints are:

### Subpart A – Car bed child restraints

Model	Manufactured on or after
Angel Guard Angel Ride AA2403FOF	September 25, 2007

### Subpart B – Rear-facing child restraints

Model	Manufactured on or after
Century SmartFit 4543	December 1, 1999
Cosco Arriva 22-013PAW and base 22-999WHO	September 25, 2007
Evenflo Discovery Adjust Right 212	December 1, 1999
Evenflo First Choice 204	December 1, 1999
Graco Infant 8457	December 1, 1999
Graco Snugride	September 25, 2007
Peg Perego Primo Viaggio SIP IMUN00US	September 25, 2007

### Subpart C – Forward-facing and convertible child restraints

Model	Manufactured on or after
Britax Roundabout E9L02xx	September 25, 2007
Cosco Touriva 02519	December 1, 1999
Cosco Summit Deluxe High Back Booster 22-262	September 25, 2007
Cosco High Back Booster 22-209	September 25, 2007
Evenflo Tribute V 379xxxx	September 25, 2007
Evenflo Medallion 254	December 1, 1999
Evenflo Generations 352xxxx	September 25, 2007
Graco ComfortSport	September 25, 2007
Graco Toddler Safety Seat Step 2	September 25, 2007
Graco Platinum Cargo	September 25, 2007



#### WARNING

To reduce the risk of serious injury, make sure that the **PASSENGER AIR BAG OFF**  light comes on and stays on whenever a child restraint is installed on the front passenger seat and the ignition is switched on.

- Take the child restraint off the front passenger seat and install it properly at one of the rear seat positions if the **PASSENGER AIR BAG OFF**  light does not stay on.
- Have the airbag system inspected by your authorized Audi dealer immediately.

### Tips

The child seats listed in categories A to C have been statically tested by Audi only for the Advanced Airbag function.

### Important safety instructions for using child safety seats

*Correct use of child safety seats substantially reduces the risk of injury in an accident!*

As the driver, you are responsible for the safety of everybody in the vehicle, especially children:

- ▶ Always use the right child safety seat for each child and always use it properly ⇒ *page 297*.
- ▶ Always carefully follow the child safety seat manufacturer's instructions on how to route the safety belt properly through the child safety seat.
- ▶ When using the vehicle safety belt to install a child safety seat, you must first activate the convertible locking retractor on the safety belt to prevent the child safety seat from moving ⇒ *page 302*.
- ▶ Push the child safety seat down with your full weight to get the safety belt really tight so that the seat cannot move forward or sideways more than one inch (2.5 cm).
- ▶ Secure unused safety belts on the rear seat ⇒ *page 297*.

Always remember: Even though your vehicle is equipped with an Advanced Airbag system, all children, especially those 12 years and younger, should always ride in the back seat properly restrained for their age and size.

### WARNING

Not using a child safety seat, using the wrong child safety seat or improperly installing a

child restraint increases the risk of serious personal injury and death.

- All vehicle occupants and especially children must be restrained properly whenever riding in a vehicle. An unrestrained or improperly restrained child could be injured by striking the interior or by being ejected from the vehicle during a sudden maneuver or impact. An unrestrained or improperly restrained child is also at greater risk of injury or death through contact with an inflating airbag.
- Commercially available child safety seats are required to comply with U.S. Federal Motor Vehicle Safety Standard (FMVSS) 213 (in Canada CMVSS 213).
  - When buying a child restraint, select one that fits your child and the vehicle.
  - Only use child restraint systems that fully contact the flat portion of the seat cushion. The child restraint must not tip or lean to either side. Audi does not recommend using child safety seats that rest on legs or tube-like frames. They do not provide adequate contact with the seat.
  - Always heed all legal requirements pertaining to the installation and use of child safety seats and carefully follow the instructions provided by the manufacturer of the seat you are using.
- Never allow children under 57 inches (1.45 meters) to wear a normal safety belt. They must always be restrained by a proper child restraint system. Otherwise, they could sustain injuries to the abdomen and neck areas during sudden braking maneuvers or accidents.
- Never let more than one child occupy a child safety seat.
- Never let babies or older children ride in a vehicle while sitting on the lap of another passenger.
  - Holding a child in your arms is never a substitute for a child restraint system.
  - The strongest person could not hold the child with the forces that exist in an accident. The child will strike the interior of the vehicle and can also be struck by the passenger.

- The child and the passenger can also injure each other in an accident.
- Never install rear-facing child safety seats or infant carriers on the front passenger seat. A child will be seriously injured and can be killed when the passenger airbag inflates – even with an Advanced Airbag System.
- The inflating airbag will hit the child safety seat or infant carrier with great force and will smash the child safety seat and child against the backrest, center armrest, door or roof.
- Always install rear-facing child safety seats or infant carriers on the rear seat.
- Before you carry a child in a rear-facing child safety seat on the rear seat, remove the Rear Seat Entertainment (RSE)\* and its holder\* from the backrest of the front seat.
- Make sure there is enough space in front of the child in the child seat. If necessary, adjust the angle and position of the seat in front of the child seat.
- Forward-facing child safety seats installed on the front passenger's seat can interfere with the airbag when it inflates and cause serious injury to the child. Always install forward-facing child safety seats on the rear seat.
- If exceptional circumstances require the use of a forward-facing child restraint on the front passenger's seat, the child's safety and well-being require that the following special precautions be taken:
  - Make sure the forward-facing seat has been designed and certified by its manufacturer for use on a front seat with a passenger front and side airbag.
  - Always carefully follow the manufacturer's instructions provided with the child safety seat or carrier.
  - Always move the front passenger seat to the highest position in the up and down adjustment range and move it back to the rearmost position in the seat's fore and aft adjustment range, as far away from the airbag as possible, before installing the forward-facing child restraint.

- Always make sure that the safety belt upper anchorage is behind the child restraint and not next to or in front of the child restraint so that the safety belt will be properly positioned.
- Always make sure that nothing prevents the front passenger's seat from being moved to the rearmost position in its fore and aft adjustment range.
- Always make sure that the backrest is in the upright position.
- Never place or use any electrical device (such as a laptop, CD player, electronic games device, power inverter or seat heater for child seats) on the front passenger seat if the device is connected to the 12-volt socket or the cigarette lighter socket.
- If a seat heater has been retrofitted or otherwise added to the front passenger seat, never install any child restraint system on this seat.
- Make sure that there are no wet objects (such as a wet towel) and no water or other liquids on the front passenger seat cushion.
- Never place objects on the seat (such as a laptop, CD player, electronic games device, power inverter or seat heater for child seats). These may influence the electrical capacitance measured by the capacitive passenger detection system and can also fly around in an accident and cause serious personal injury.
- Always buckle the child safety seat firmly in place even if a child is not sitting in it. A loose child safety seat can fly around during a sudden stop or in a collision.
- Always read and heed all WARNINGS whenever using a child restrained in a vehicle is being used ⇒ *page 261, Safety belts*, ⇒ *page 269, Airbag system* and ⇒ *page 291, Child safety*.

### **WARNING**

To reduce the risk of serious injury, make sure that the **PASSENGER AIR BAG OFF**  light

comes on and stays on whenever a child restraint is installed on the front passenger seat and the ignition is switched on.

- Take the child restraint off the front passenger seat and install it properly at one of the rear seat positions if the **PASSENGER AIR BAG OFF**  light does not stay on.
- Have the airbag system inspected by your authorized Audi dealer immediately.

### Secure unused safety belts on the rear seat



**Fig. 241** Schematic overview: keep unused safety belts away from children in child safety seats. **A** - outer rear safety belt, **B** - center rear safety belt

If a child safety seat is used on the rear bench, especially with LATCH universal lower anchorages, the unused safety belts **must** be secured so that the child in the child restraint cannot reach them ⇒ .

- Guide the safety belt webbings **A** and **B** behind the head restraint of the seat where the child restraint is installed ⇒ *fig. 241*. When doing so, do not engage the convertible locking retractor! You should not hear a “clicking” sound when winding up the safety belt.
- Let the belt retractor wind up the safety belt webbing.

### WARNING

A child in a child safety seat installed with the LATCH lower anchorages or with the standard safety belt or a child in a booster seat on the rear seat could play with unused rear seat safety belts and become entangled. This could cause the child serious personal injury and even death.

- Always secure unused rear seat safety belts out of reach of children in child seats such as by properly routing them around the head restraint of the seat where the child restraint is installed.
- Never activate the convertible locking retractor when routing the safety belts around the head restraints.
- Never let anyone sit at the center rear seating position if the center rear safety belt has been routed around a rear head restraint.

## Child safety seats

### Infant seats

Babies and infants up to about one year old and 20 lbs. or 9 kg need special rearward-facing child restraints that support the back, neck and head in a crash.



**Fig. 242** Schematic overview: rearward-facing infant seat, properly installed on the rear seat

- ▶ When using the vehicle safety belt to install a child safety seat, you must first activate the convertible locking retractor on the safety belt to prevent the child safety seat from moving ⇒ *page 302* or install the seat using the LATCH attachments.
- ▶ Push the child safety seat down with your full weight to get the safety belt really tight so that the seat cannot move forward or sideways more than one inch (2.5 cm).
- ▶ Secure unused safety belts on the rear seat ⇒ *page 297*.

Infants up to about one year (20 lbs. or 9 kg) are best protected in special infant carriers and child safety seats designed for their age group. Many experts believe that infants and small children

should ride only in special restraints in which the child faces the back of the vehicle. These infant seats support the baby's back, neck and head in a crash ⇒ *fig. 242*.

The airbag on the passenger side makes the front seat a potentially dangerous place for a child to ride. The front seat is not the safest place for a child in a forward-facing child seat. It is a very dangerous place for an infant or a larger child in a rearward-facing seat.

### **WARNING**

Not using a child safety seat, using the wrong child safety seat or improperly installing a child restraint increases the risk of serious personal injury and death in a crash.

- Never install rear-facing child safety seats or infant carriers on the front passenger seat – even with an Advanced Airbag System. A child will be seriously injured and can be killed when the inflating airbag hits the child safety seat or infant carrier with great force and smashes the child safety seat and child against the backrest, center armrest, door or roof ⇒ *page 270, Child restraints on the front seat – some important things to know*.
- Always install rear-facing child safety seats or infant carriers on the rear seat.
- Never install a rear-facing child restraint in the forward-facing direction. Such restraints are designed for the special needs of infants and very small children and cannot protect them properly if the seat is forward-facing.
- If you must install a rearward facing child safety seat on the front passenger seat because of exceptional circumstances and the **PASSENGER AIR BAG OFF**  light does not come on and stay on, immediately install the rear-facing child safety seat in a rear seating position and have the airbag system inspected by your Audi dealer.
- Never place or use any electrical device (such as a laptop, CD player, electronic games device, power inverter or seat heater for child seats) on the front passenger seat

if the device is connected to the 12-volt socket or the cigarette lighter socket.

- If a seat heater has been retrofitted or otherwise added to the front passenger seat, never install any child restraint system on this seat.
- Make sure that there are no wet objects (such as a wet towel) and no water or other liquids on the front passenger seat cushion.
- Never place objects on the seat (such as a laptop, CD player, electronic games device, power inverter or seat heater for child seats). These may influence the electrical capacitance measured by the capacitive passenger detection system and can also fly around in an accident and cause serious personal injury.
- Always read and heed all WARNINGS whenever using a child restrained in a vehicle is being used ⇒ *page 261, Safety belts*, ⇒ *page 269, Airbag system* and ⇒ *page 291, Important information*.

**Convertible child safety seats**

Properly used convertible child safety seats can help protect toddlers and children over age one who weigh between 20 and 40 lbs. (9 and 18 kg) in a crash.

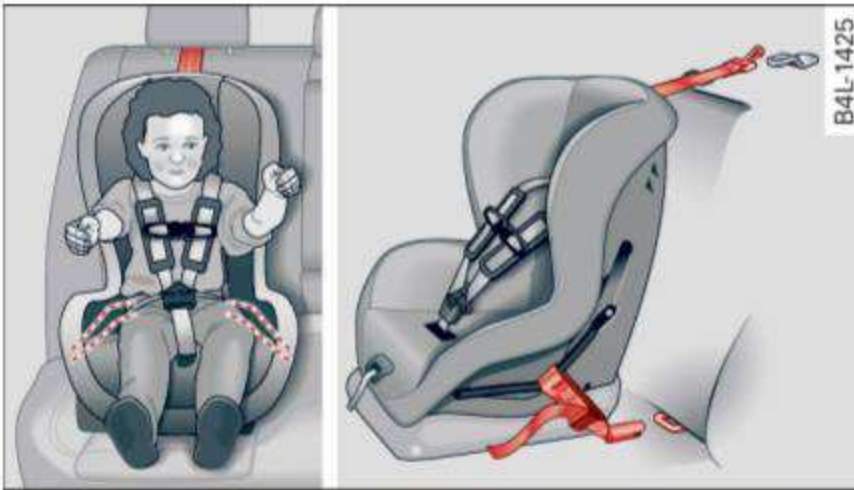

**Fig. 243** Schematic overview: installation of the attachments applicable to a LATCH seat

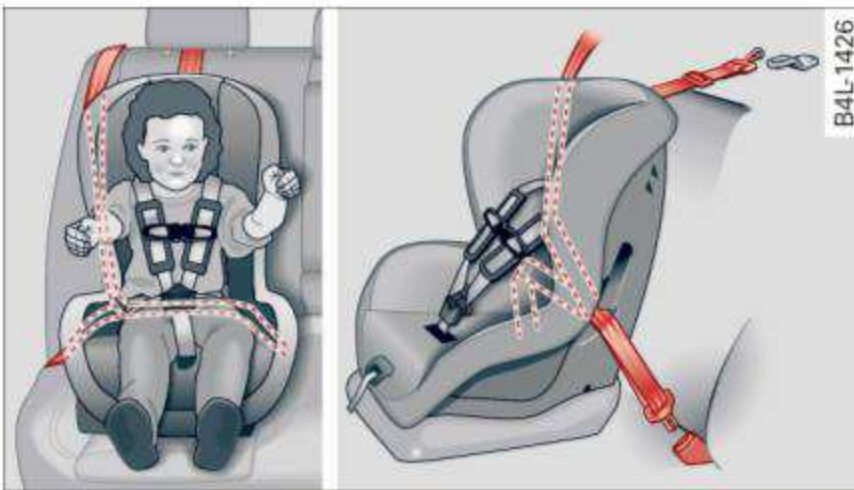

**Fig. 244** Schematic overview: installation of the seat using the vehicle's safety belt system

- ▶ When using the vehicle safety belt to install a child safety seat, you must first activate the convertible locking retractor on the safety belt to prevent the child safety seat from moving ⇒ *page 302* or install the seat using the LATCH attachments.
- ▶ Push the child safety seat down with your full weight to get the safety belt really tight so that the seat cannot move forward or sideways more than one inch (2.5 cm) ⇒ *page 302*.
- ▶ If the child safety seat is equipped with a tether strap, attach it to the tether anchors ⇒ *page 308*.
- ▶ Secure unused safety belts on the rear seat ⇒ *page 297*.

A toddler or child is usually too large for an infant restraint if it is more than one year old and weighs more than 20 lbs. (9 kg).

Toddlers and children who are older than one year up to about 4 years old and weigh more than 20 lbs. (9 kg) up to 40 lbs. (18 kg) must always be properly restrained in a child safety seat certified for their size and weight ⇒ *fig. 243* and ⇒ *fig. 244*.

The airbag on the passenger side makes the front seat a potentially dangerous place for a child to ride. The front seat is not the safest place for a child in a forward-facing child safety seat. It is a very dangerous place for an infant or a larger child in a rearward-facing seat.

**! WARNING**

Not using a child safety seat, using the wrong child safety seat or improperly installing a child restraint increases the risk of serious personal injury and death in a collision or other emergency situation.

- Children on the front seat of any car, even with Advanced Airbags, can be seriously injured or even killed when an airbag inflates. A child in a rearward-facing child safety seat installed on the front passenger seat will be seriously injured and can be killed if the front airbag inflates – even with an Advanced Airbag System.
- The inflating airbag will hit the child safety seat or infant carrier with great force and will smash the child safety seat and child against the backrest, center armrest, door or roof.
- Always install rear-facing child safety seats on the rear seat.
- If you must install a rearward facing child safety seat on the front passenger seat because of exceptional circumstances and the **PASSENGER AIR BAG OFF**  light does not come on and stay on, immediately install the rear-facing child safety seat in a rear seating position and have the airbag system inspected by your Audi dealer.
- The rear side of the child safety seat should be positioned as close as possible to the backrest on the vehicle seat. Adjust or remove the rear seat head restraint if it is difficult to install the child seat with the head

restraint in place ⇒ *page 58*. Install the head restraint again immediately once the child seat is removed. Driving without head restraints or with head restraints that are not properly adjusted increases the risk of serious or fatal neck injury dramatically.



- Always read and heed all WARNINGS whenever using a child restrained in a vehicle is being used ⇒ *page 261, Safety belts*, ⇒ *page 269, Airbag system* and ⇒ *page 291, Important information*.

### WARNING

If exceptional circumstances require the use of a forward-facing child restraint on the front passenger's seat, the child's safety and well-being require that the following special precautions be taken:

- Make sure the forward-facing seat has been designed and certified by its manufacturer for use on a front seat with a passenger front and side airbag.
- Always follow the manufacturer's instructions provided with the child safety seat or infant carrier.
- Always move the front passenger seat to the highest position in the up and down adjustment range and move it back to the rearmost position in the seat's fore and aft adjustment range, as far away from the airbag as possible, before installing the forward-facing child restraint.
- Always make sure that the safety belt upper anchorage is behind the child restraint and not next to or in front of the child restraint so that the safety belt will be properly positioned.
- Always make sure that nothing prevents the front passenger's seat from being moved to the rearmost position in its fore and aft adjustment range.
- Always make sure the backrest is in an upright position.
- Never place or use any electrical device (such as a laptop, CD player, electronic games device, power inverter or seat heater for child seats) on the front passenger seat

if the device is connected to the 12-volt socket or the cigarette lighter socket.

- If a seat heater has been retrofitted or otherwise added to the front passenger seat, never install any child restraint system on this seat.
- Make sure that there are no wet objects (such as a wet towel) and no water or other liquids on the front passenger seat cushion.
- Never place objects on the seat (such as a laptop, CD player, electronic games device, power inverter or seat heater for child seats). These may influence the electrical capacitance measured by the capacitive passenger detection system and can also fly around in an accident and cause serious personal injury.
- Make sure that the **PASSENGER AIR BAG OFF**  light comes on and stays on all the time whenever the ignition is switched on.
- If the **PASSENGER AIR BAG OFF**  light does not come on and stay on, immediately install the forward-facing child seat at a seating position on the rear seat and have the airbag system inspected by your authorized Audi dealer.
- Take the child restraint off the front passenger seat and install it properly at one of the rear seat positions if the **PASSENGER AIR BAG OFF**  light does not stay on whenever the ignition is switched on.

## Booster seats and safety belts

Properly used booster seats can help protect children weighing between about 40 lbs. and 80 lbs. (18 kg and 36 kg) who are less than 4 ft. 9 in. (57 inches/1.45 meters) tall.



**Fig. 245** Rear seat: child properly restrained in a booster seat

The vehicle's safety belts alone will not fit most children until they are at least 4 ft. 9 in. (57 inches/1.45 meters) tall and weigh about 80 lbs. (36 kg). Booster seats raise these children up so that the safety belt will pass properly over the stronger parts of their bodies and the safety belt can help protect them in a crash.

- ▶ Do not use the convertible locking retractor when using the vehicle's safety belt to restrain a child on a booster seat.
- ▶ The shoulder belt must lie as close to the center of the child's collar bone as possible and must lie flat and snug on the upper body. It must never lie across the throat or neck. The lap belt must lie across the pelvis and never across the stomach or abdomen. Make sure the belt lies flat and snug. Pull on the belt to tighten if necessary.
- ▶ If you must transport an older child in a booster seat on the front passenger seat, you can use the safety belt height adjustment to help adjust the shoulder portion properly.
- ▶ Secure unused safety belts on the rear seat ⇒ page 297.

Children up to at least 8 years old (over 40 lbs. or 18 kg) are best protected in child safety seats designed for their age and weight. Experts say that the skeletal structure, particularly the pelvis, of these children is not fully developed, and they

must not use the vehicle safety belts without a suitable child restraint.

It is usually best to put these children in appropriate booster seats. Be sure the booster seat meets all applicable safety standards.

Booster seats raise the seating position of the child and reposition both the lap and shoulder parts of the safety belt so that they pass across the child's body in the right places. The routing of the belt over the child's body is very important for the child's protection, whether or not a booster seat is used. Children age 12 and under must always ride in the rear seat.

Children who are at least 4 ft. 9 in. (57 inches/1.45 meters) tall can generally use the vehicle's three point lap and shoulder belts. Never use the lap belt portion of the vehicle's safety belt alone to restrain any child, regardless of how big the child is. Always remember that children do not have the pronounced pelvic structure required for the proper function of lap belt portion of the vehicle's three point lap and shoulder belts. The child's safety absolutely requires that a lap belt portion of the safety belt be fastened snugly and as low as possible around the pelvis. Never let the lap belt portion of the safety belt pass over the child's stomach or abdomen.

In a crash, airbags must inflate within a blink of an eye and with considerable force. In order to do its job, the airbag needs room to inflate so that it will be there to protect the occupant as the occupant moves forward into the airbag.

A vehicle occupant who is out of position and too close to the airbag gets in the way of an inflating airbag. When an occupant is too close, he or she will be struck violently and will receive serious or possibly even fatal injury.

In order for the airbag to offer protection, it is important that all vehicle occupants, especially any children, who must be in the front seat because of exceptional circumstances, be properly restrained and as far away from the airbag as possible. By keeping room between the child's



body and the front of the passenger compartment, the airbag can inflate completely and provide supplemental protection in certain frontal collisions.

### **WARNING**

Not using a booster seat, using the booster seat improperly, incorrectly installing a booster seat or using the vehicle safety belt improperly increases the risk of serious personal injury and death in a collision or other emergency situation. To help reduce the risk of serious personal injury and/or death:

- The shoulder belt must lie as close to the center of the child's collar bone as possible and must lie flat and snug on the upper body. It must never lie across the throat or neck. The lap belt must lie across the pelvis and never across the stomach or abdomen. Make sure the belt lies flat and snug. Pull on the belt to tighten if necessary.
- Failure to properly route safety belts over a child's body will cause severe injuries in an accident or other emergency situation ⇒ *page 261*.
- The rear side of the child safety seat should be positioned as close as possible to the backrest on the vehicle seat. Adjust or remove the rear seat head restraint if it is difficult to install the child seat with the head restraint in place ⇒ *page 58*. Install the head restraint again immediately once the child seat is removed. Driving without head restraints or with head restraints that are not properly adjusted increases the risk of serious or fatal neck injury dramatically.
- Never let a child put the shoulder belt under the arm or behind the back, because it could cause severe injuries in a crash.
- Children on the front seat of any car, even with Advanced Airbags, can be seriously injured or even killed when an airbag inflates.
- Never let a child stand or kneel on any seat, for example the front seat.
- Never let a child ride in the cargo area of your vehicle.
- Always remember that a child leaning forward, sitting sideways or out of position in

any way during an accident can be struck by a deploying airbag. This will result in serious personal injury or death.

- If you must install a booster seat on the front passenger seat because of exceptional circumstances the **PASSENGER AIR BAG OFF**  light must come on and stay on, whenever the ignition is switched on.
- If the **PASSENGER AIR BAG OFF**  light does not come on and stay on, perform the checks described ⇒ *page 281, Monitoring the Advanced Airbag System*.
- Take the child restraint off the front passenger seat and install it properly at one of the rear seat positions if the **PASSENGER AIR BAG OFF**  light does not stay on whenever the ignition is switched on.
- Always read and heed all WARNINGS whenever using a child restrained in a vehicle is being used ⇒ *page 261, Safety belts*, ⇒ *page 269, Airbag system* and ⇒ *page 291, Important information*.

## Securing child safety seats

### Securing a child safety seat using a safety belt

*Safety belts for the rear seats and the front passenger can be locked with the convertible locking retractor to properly secure child safety seats.*

The safety belts for the rear seats and for the front passenger's seat have a convertible locking retractor for child safety seats. The safety belt must be locked so that belt webbing cannot un-reel. The retractor can be activated to lock the safety belt and prevent the safety belt webbing from loosening up during normal driving. A child safety seat can only be properly installed when the safety belt is locked so that the child and child safety seat will stay in place.

Always remember: Even though your vehicle is equipped with an Advanced Airbag system, all children, especially those 12 years and younger, should always ride in the back seat properly restrained for their age and size. ►

**! WARNING**





Improperly installed child safety seats increase the risk of serious personal injury and death in a collision.

- Always make sure that the safety belt retractor is locked when installing a child safety seat. An unlocked safety belt retractor cannot hold the child safety seat in place during normal driving or in a crash.
- Always buckle the child safety seat firmly in place even if a child is not sitting in it. A loose child safety seat can fly around during a sudden stop or in a collision.
- Always make sure that the rear seat backrest to which the center rear safety belt\* is attached is securely latched whenever the rear center safety belt is being used to secure a child restraint.
- If the backrest is not securely latched, the child and the child restraint will be thrown forward together with the backrest and will strike parts of the vehicle interior. The child can be seriously injured or killed.
- Never install rear-facing child safety seats or infant carriers on the front passenger seat. A child will be seriously injured and can be killed when the passenger airbag inflates.
- The inflating airbag will hit the child safety seat or infant carrier with great force and will smash the child safety seat and child against the backrest, center armrest, door or roof.
- Always install rear-facing child safety seats or infant carriers on the rear seat.
- Forward-facing child safety seats or infant carriers installed on the front passenger's seat may interfere with the deployment of the airbag and cause serious injury to the child.
- It is safer to install a forward-facing child safety seat on the rear seat.
- Always read and heed all WARNINGS whenever using a child restrained in a vehicle is being used ⇒ *page 291*. Special precautions apply when installing a child safety seat on the front passenger seat ⇒ *page 270, Child*

*restraints on the front seat – some important things to know.*

**! WARNING**

Always take special precautions if you must install a forward or rearward-facing child restraint on the front passenger's seat in exceptional situations:

- Whenever a forward or rearward-facing child restraint is installed on the front passenger seat, the **PASSENGER AIR BAG OFF**  light must come on and stay on whenever the ignition is switched on.
- If the **PASSENGER AIR BAG OFF**  light does not come on and stay on, perform the checks described ⇒ *page 281, Monitoring the Advanced Airbag System*.
- Take the child restraint off the front passenger seat and install it properly at one of the rear seat positions if the **PASSENGER AIR BAG OFF**  light does not stay on whenever the ignition is switched on.
- Improper installation of child restraints can reduce their effectiveness or even prevent them from providing any protection.
- An improperly installed child restraint can interfere with the airbag as it deploys and seriously injure or even kill the child.
- Always carefully follow the manufacturer's instructions provided with the child safety seat or carrier.
- After checking to make sure that the child restraint is properly installed, make certain that the child restraint is correctly recognized by the capacitive passenger detection system in the front passenger seat and that the **PASSENGER AIR BAG OFF**  light signals the correct front passenger frontal airbag status.

**! WARNING**



Forward-facing child restraints:

- Always make sure the forward-facing seat has been designed and certified by its manufacturer for use on a front seat with a passenger front and side airbag.

- Never put the forward-facing child restraint up, against or very near the instrument panel.
- Always move the front passenger seat to the highest position in the up and down adjustment range and move it back to the rearmost position in the seat's fore and aft adjustment range, as far away from the airbag as possible, before installing the forward-facing child restraint.
- Always make sure that the safety belt upper anchorage is behind the child restraint and not next to or in front of the child restraint so that the safety belt will be properly positioned.
- Make sure that the **PASSENGER AIR BAG OFF**  light comes on and stays on all the time whenever the ignition is switched on.

### **WARNING**

Rearward-facing child restraints:

- A child in a rearward-facing child safety seat installed on the front passenger seat will be seriously injured and can be killed if the front airbag inflates – even with an Advanced Airbag System.
- The inflating airbag will hit the child safety seat or infant carrier with great force and will smash the child safety seat and child against the backrest, center armrest, door or roof.
- Always be especially careful if you must install a rearward facing child safety seat on the front passenger seat in exceptional circumstances.
- Make sure that the **PASSENGER AIR BAG OFF**  light comes on and stays on all the time whenever the ignition is switched on.
- If the **PASSENGER AIR BAG OFF**  light does not come on and stay on, immediately install the rear-facing child safety seat in a rear seating position and have the airbag system inspected by your Audi dealer.

### **Activating the convertible locking retractor**

*Use the convertible locking retractor to secure a child restraint.*

Always heed the child safety seat manufacturer's instructions when installing a child restraint in your vehicle. To activate the convertible locking retractor:

- ▶ Place the child restraint on a seat, preferably on the rear seat.
- ▶ Slowly pull the belt **all the way out**.
- ▶ Route it around or through the child restraint belt path ⇒ .
- ▶ Push the child safety seat down with your full weight to get the safety belt really tight.
- ▶ Insert the belt tongue into the buckle for that seating position.
- ▶ Guide the safety belt back into the retractor until the belt lies flat and snug on the child safety seat.
- ▶ You should hear a “clicking” noise as the belt winds back into the inertia reel. Test the convertible locking retractor by pulling on the belt. You should no longer be able to pull the belt out of the retractor. The convertible locking retractor is now activated.
- ▶ Make sure that the red release button is facing away from the child restraint so that it can be unbuckled quickly.
- ▶ Pull on the belt to make sure the safety belt is properly tight and fastened so that the seat cannot move forward or sideways more than one inch (2.5 cm).

### **WARNING**

Using the wrong child restraint or an improperly installed child restraint can cause serious personal injury or death in a crash.

- Always make sure that the safety belt retractor is locked when installing a child safety seat. An unlocked safety belt retractor cannot hold the child safety seat in place during normal driving or in a crash.
- Always buckle the child safety seat firmly in place even if a child is not sitting in it. A loose child safety seat can fly around during a sudden stop or in a crash.

- Always make sure the seat backrest to which the child restraint is installed is in an upright position and securely latched into place and cannot fold forward. Otherwise, the seatback with the child safety seat attached to it could fly forward in the event of an accident or other emergency situation.
- Always read and heed all WARNINGS whenever using a child restrained in a vehicle is being used ⇒ *page 291*. Special precautions apply when installing a child safety seat on the front passenger seat ⇒ *page 270, Child restraints on the front seat – some important things to know*.

### Deactivating the convertible locking retractor

*The convertible locking retractor for child restraints will be deactivated automatically when the belt is wound all the way back into the retractor.*

- ▶ Press the red button on the safety belt buckle. The belt tongue will pop out of the buckle.
- ▶ Guide the safety belt all the way back into its stowed position.

Always let the safety belt retract completely into its stowed position. The safety belt can now be used as an ordinary safety belt without the convertible locking retractor for child restraints.

If the convertible locking retractor should be activated inadvertently, the safety belt must be unfastened and guided completely back into its stowed position to deactivate this feature. If the convertible locking retractor is not deactivated, the safety belt will gradually become tighter and uncomfortable to wear.

### WARNING

- Improperly installed child safety seats increase the risk of serious personal injury and death in a collision.
- Never unfasten the safety belt to deactivate the convertible locking retractor for child restraints while the vehicle is moving. You

would not be restrained and could be seriously injured in an accident.

- Always read and heed all WARNINGS whenever using a child restrained in a vehicle is being used ⇒ *page 291*. Special precautions apply when installing a child safety seat on the front passenger seat ⇒ *page 270, Child restraints on the front seat – some important things to know*.

## LATCH system (lower anchorages and tethers for children)

### Child Restraint System anchors and how are they related to child safety

To provide a simpler and more practicable way to attach the child restraint on the vehicle seat, Federal regulations require special lower anchorages in vehicles and devices on new child restraints to attach to the vehicle anchorages.

In the United States, the combination of the tether anchorages and the lower anchorages is now generally called the LATCH system for “**L**ower **A**ncorages and **T**ethers for **C**hildren”. In Canada, the terms “top tether” with “lower universal anchorages” (or “lower universal anchorage bars”) are used to describe the system.

In other countries the term “ISOFIX” is used to describe the lower anchorages.

Forward-facing child restraints manufactured after September 1, 1999, are required by U.S. federal regulations to comply with new child head movement performance requirements. These new performance requirements make a tether necessary on most new child seats.

Installing a child restraint that requires a top tether without one can seriously impair the performance of the child restraint and its ability to protect the child in a collision. Installing a child restraint that requires a top tether without the top tether may be a violation of state law.

Child restraint manufacturers offer LATCH lower anchorages on their child seats with hook-on or ▶

## Child safety

push-on connectors attached to adjustable straps.

In addition to the LATCH lower anchorages, these child restraint systems usually require the use of tether straps to help keep the child restraint firmly in place.

### WARNING

Improper installation of child restraints will increase the risk of injury and death in a crash.

- Always follow the instructions provided by the manufacturer of the child restraint you intend to install in your vehicle.
- Never install a child restraint without a properly attached top tether strap if the child restraint manufacturer's instructions require the top tether strap to be used.
- Improper use of child restraint LATCH lower anchor points can lead to injury in a collision. The LATCH lower anchor points are designed to withstand only those loads imposed by correctly fitted child restraints.
- Never mount two child restraint systems on one LATCH lower anchorage point.
- Never secure or attach any luggage or other item to the LATCH lower anchorages.

### Location

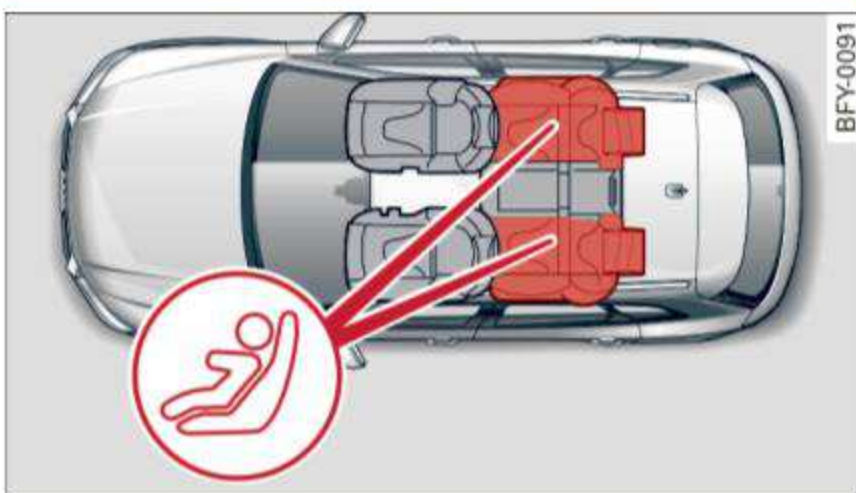

Fig. 246 Schematic overview: LATCH anchorage point locations

The illustration shows the seating locations in your vehicle which are equipped with the lower anchorages system.

### Description

The lower anchorage positions are marked for quick locating.



Fig. 247 Rear seats: lower anchorage covers



Fig. 248 Rear seats: lower anchorage bracket locations

### Lower anchorages

The lower anchorage attachment points are located between the rear seatback and rear seat cushion ⇒ *fig. 247*, ⇒ *fig. 248*.

Lower anchorages secure the child restraint in the seat without using the vehicle's safety belts. Anchorages provide a secure and easy-to-use attachment and minimize the possibility of improper child restraint installation.

All child restraints manufactured after September 1, 2002, must have lower anchorage attachments for the *LATCH* system.

Remember that the lower anchorage points are only intended for installation and attachment of child restraints specifically certified for use with *LATCH* lower anchorages. Child restraints that are not equipped with the lower anchorage attachments can still be installed in compliance with the child restraint manufacturer's instructions on using vehicle safety belts. ▶

**! WARNING**

Improper use of LATCH lower anchorages can cause serious personal injury in an accident.

- Always carefully follow the child restraints manufacturer's instructions for proper installation of the child restraint and proper use of the lower anchorages or safety belts in your vehicle.
- Never secure or attach any luggage or other items to the *LATCH* lower anchorages.
- Always read and heed the important information about child restraints in this chapter and WARNINGS ⇒ *page 291, Child safety.*

### Installing a child restraint with LATCH lower anchorages

Whenever you install a child restraint always follow the child restraint manufacturer's instructions.

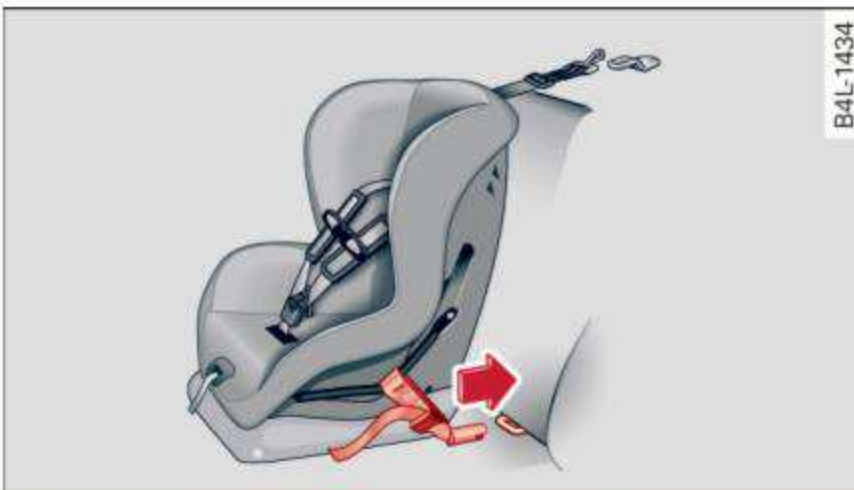

Fig. 249 Lower anchorages: proper mounting

#### Mounting

- ▶ Make sure the seatback of the rear seat bench is in the upright position and securely latched in place.
- ▶ Remove the covers to access the lower anchorage brackets.
- ▶ Attach both hook-on connectors with the spring catch release on the child safety seat onto the LATCH lower anchorage so that the connectors lock into place ⇒ *fig. 249.*
- ▶ Pull on the connector attachments to make sure they are properly attached to the LATCH lower anchorage.
- ▶ Pull straps tight following the child restraint manufacturer's instructions.

#### Releasing

- ▶ Loosen the tension on the straps following the child restraint manufacturer's instructions.
- ▶ Depress the spring catches to release the anchorage hooks from the lower anchorages.

Remember: Use tether straps to help keep the child restraint firmly in place.

**! WARNING**

Improper use of the LATCH system can increase the risk of serious personal injury and death in an accident.

- These anchors were developed only for child safety seats using the “LATCH” system.
- Never attach other child safety seats, belts or other objects to these anchors.
- Always make sure that you hear a click when latching the seat in place. If you do not hear a click the seat is not secure and could fly forward and hit the interior of the vehicle, or be ejected from the vehicle.

**! WARNING**

Improper installation of child restraints will increase the risk of injury in an accident.

- Always follow the child restraint system manufacturer's instructions for proper installation of the child restraint system and proper use of tether straps as well as the lower anchorages or safety belts in your vehicle.
- Always read and heed the important information and WARNINGS about child safety and the installation of child restraint systems ⇒ *page 291, Child safety.*

### Tether anchors and tether straps

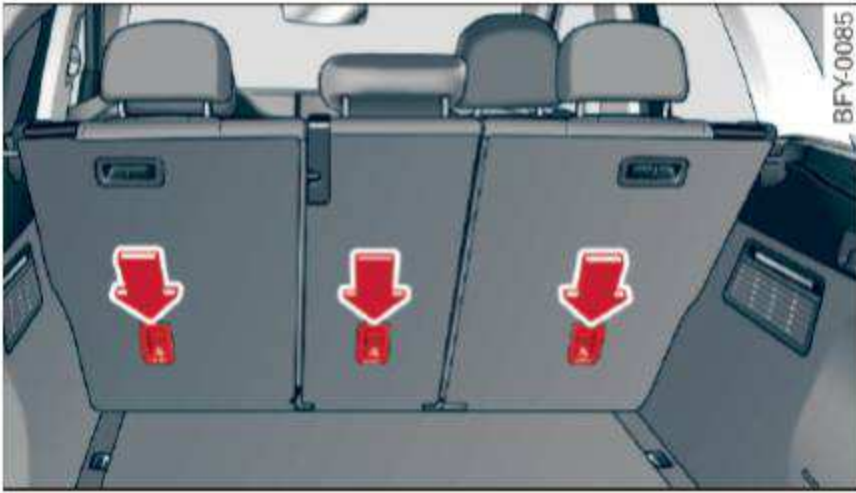

Fig. 250 Tether anchors for second row of seats: attachment hook locations

The tether anchors for the rear seating positions are located on the backside of the rear seatbacks.

A tether is a straight or V-shaped strap that attaches the top part of a child restraint to special anchorage points in the vehicle.

The purpose of the tether is to reduce the forward movement of the child restraint in a crash, in order to help reduce the risk of head injury that could be caused by striking the vehicle interior.

Forward facing child restraints manufactured after September 1, 1999, are required by U.S. federal regulations to comply with new child head movement performance requirements. These new performance requirements make a tether necessary on most new child safety seats.

#### WARNING

Improper installation of child restraints will increase the risk of injury and death in a crash.

- Always follow the instructions provided by the manufacturer of the child restraint you intend to install in your Audi.
- Improper use of child restraint anchors (including tether anchors) can lead to injury in a collision. The anchors are designed to withstand only those loads imposed by correctly fitted child restraints.
- Never mount two child restraint systems on one LATCH lower anchor point.
- Never attach two child restraint systems to one tether strap or tether anchorage.

- Never attach a tether strap to a tie-down hook in the luggage compartment.
- Never use child restraint tether anchorages to secure safety belts or other kinds of occupant restraints.
- Never secure or attach any luggage or other items to the LATCH lower anchorages or to the tether anchors.

### Installing the upper tether strap on the anchorage



Fig. 251 Tether strap: proper routing and mounting

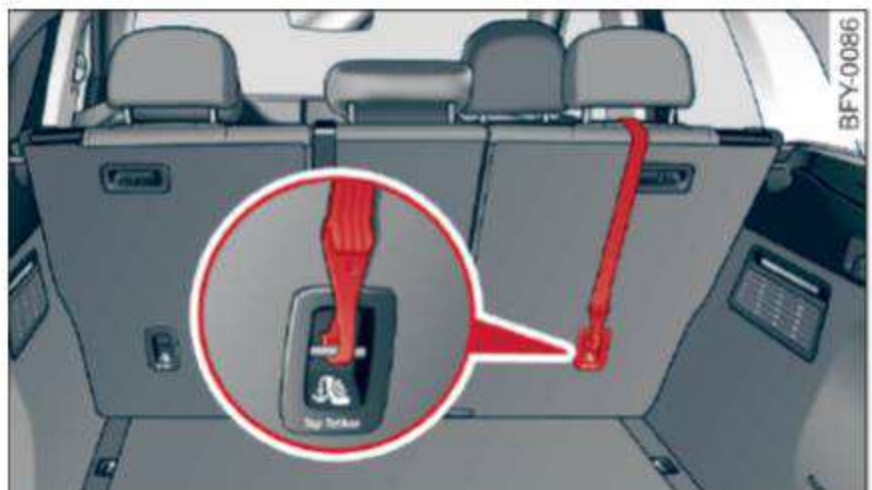

Fig. 252 Tether strap: proper routing and mounting

### Installing the tether strap

- ▶ Release or deploy the tether strap on the child restraint according to the child restraint manufacturer's instructions.
- ▶ Guide the upper tether strap **under** the rear head restraint and into the rear cargo area (raise the head restraint if necessary). For child restraints with V-tether straps, always make sure that the head restraint guide rods do not interfere with any part of the top tether strap.
- ▶ Slide the tether strap hook over the anchor bracket.
- ▶ Pull on the tether strap hook so that the spring catch of the hook engages.

- ▶ Tighten the tether strap firmly following the child restraint manufacturer's instructions.

### Releasing the tether strap

- ▶ Loosen the tension following the child restraint manufacturer's instructions.
- ▶ Depress the spring catch on the hook and release it from the anchorage.

### Note

If you leave the child restraint with the tether strap firmly installed for several days, this could leave a mark on the upholstery on the seat cushion and backrest in the area where the tether strap was installed. The upholstery would also be permanently stretched around the tether strap. This applies especially to leather seats.

### Using tether straps on rearward-facing child restraints

Currently, few rear-facing child restraint systems come with a tether. Please read and heed the child restraint system manufacturer's instructions carefully to determine how to properly install the tether.

### WARNING

A child in a rearward-facing child safety seat installed on the front passenger seat will be seriously injured and can be killed if the front airbag inflates – even with an Advanced Airbag System.

- The inflating airbag will hit the child safety seat or infant carrier with great force and will smash the child safety seat and child against the backrest, center armrest, or door.
- If you must install a rearward facing child safety seat on the front passenger seat because of exceptional circumstances and the **PASSENGER AIR BAG OFF**  light does not come on and stay on, immediately install the rear-facing child safety seat in a rear seating position and have the airbag system inspected by your Audi dealer.

## Additional information

### Sources of information about child restraints and their use

There are a number of sources of additional information about child restraint selection, installation and use:

NHTSA advises that the best child safety seat is the one that fits your child and fits in your vehicle, and that you will use correctly and consistently.

Try before you buy!

#### U.S. National Highway Traffic Safety Administration

Tel.: 1-888-327-4236 (TTY: 1-800-424-9153)  
<http://www.nhtsa.gov>  
<http://www.safercar.gov>

#### National SAFE KIDS Campaign

Tel.: (202) 662-0600  
<http://www.safekids.org>

#### Safety BeltSafe U.S.A.

Tel.: (800) 745-SAFE (English)  
 Tel.: (800) 747-SANO (Spanish)  
<http://www.carseat.org>

#### Transport Canada Information Centre

Tel.: 1-800-333-0371 or call 1-613-998-8616 if you are in the Ottawa area  
<http://www.tc.gc.ca/eng/roadsafety/menu.htm>

#### Audi Customer Relations

Tel.: (800) 822-2834

## Checking and Filling

### Fuel

#### Gasoline grade

Applies to: vehicles with gasoline engines

*The correct gasoline grade is stated on the inside of the fuel filler door.*

The vehicle is equipped with a catalytic converter and must only be driven with **unleaded gasoline**.

Audi recommends using TOP TIER Detergent Gasoline. Additional information on TOP TIER Detergent Gasoline can be found on the official website ([www.toptiergas.com](http://www.toptiergas.com)).

The individual gasoline grades are differentiated by **octane ratings**. This value is given with (R+M)/2 equating to AKI or in RON.

The following headings match the corresponding sticker in the fuel filler door.

#### **UNLEADED FUEL ONLY MIN. (R+M)/2 87 Regular / MIN. RON 91 Regular**

Use regular gasoline with minimum 87 AKI / 91 RON ⇒ ⚠.

The maximum engine power is only reached if premium gasoline 91 AKI / 95 RON is used.

#### **UNLEADED FUEL ONLY PREMIUM MIN. (R+M)/2 91 / SUPER MIN. RON 95**

Using premium gasoline with minimum 91 AKI / 95 RON is recommended.

If premium gasoline is not available, you can also use regular gasoline 87 AKI / 91 RON. However this does reduce the engine power slightly.

#### ⚠ Note

- Filling the tank just one time with leaded fuel or other metallic additives will cause permanent deterioration to the catalytic converter function.
- When gasoline with an octane rating that is too low is used, high speeds or heavy engine load can lead to engine damage.

#### ⓘ Tips

The vehicle may be filled with fuel that has a higher octane rating than what is required by the engine.

#### Blended gasoline

Applies to: vehicles with gasoline engine

#### **Use of gasoline containing alcohol or MTBE (methyl tertiary butyl ether)**

You may use unleaded gasoline blended with alcohol or MTBE (commonly referred to as oxygenates) if the blended mixture meets the following criteria:

#### **Blend of gasoline methanol (wood alcohol or methyl alcohol)**

- Anti-knock index must be 87 AKI or higher.
- Blend must contain no more than 3% methanol.
- Blend must contain more than 2% co-solvents.

#### **Blend of gasoline and ethanol (grain alcohol or ethyl alcohol)**

- Anti-knock index must be 87 AKI or higher.
- Blend must not contain more than 15% ethanol.

#### **Blend of gasoline and MTBE**

- Anti-knock index must be 87 AKI or higher.
- Blend must not contain more than 15% MTBE.

#### **Seasonally adjusted gasoline**

Many gasoline grades are blended to perform especially well for winter or summer driving. During seasonal change-over, we suggest that you fill up at busy gas stations where the seasonal adjustment is more likely to be made in time.

#### ⚠ Note

- Methanol fuels which do not meet these requirements may cause corrosion and damage to plastic and rubber components in the fuel system.
- Do not use fuels that fail to meet the specified criteria in this chapter.

- If you are unable to determine whether or not a particular fuel blend meets the specifications, ask your service station or its fuel supplier.
- Do not use fuel for which the contents cannot be identified.
- Fuel system damage and performance problems resulting from the use of fuels different from those specified are not the responsibility of Audi and are not covered under the New Vehicle or the Emission Control System Warranties.
- If you experience a loss of fuel economy or driveability and performance problems due to the use of one of these fuel blends, we recommend that you switch to unblended fuel.

### Gasoline additives

A major concern among many auto manufacturers is carbon deposit build-up caused by the type of gasoline you use.

Although gasoline grades differ from one manufacturer to another, they have certain things in common. All gasoline grades contain substances that can cause deposits to collect on vital engine parts, such as fuel injectors and intake valves. Although most gasoline brands include additives to keep engine and fuel systems clean, they are not equally effective.

Audi recommends using TOP TIER Detergent Gasoline. For more information on TOP TIER Detergent Gasoline, please go to the official website ([www.toptiergas.com](http://www.toptiergas.com)).

After an extended period of using inadequate fuels, carbon deposit build-ups can rob your engine of peak performance.

#### Note

Damage or malfunction due to poor fuel quality is not covered by the Audi New Vehicle Limited Warranty.

## Refueling

### Fueling procedure

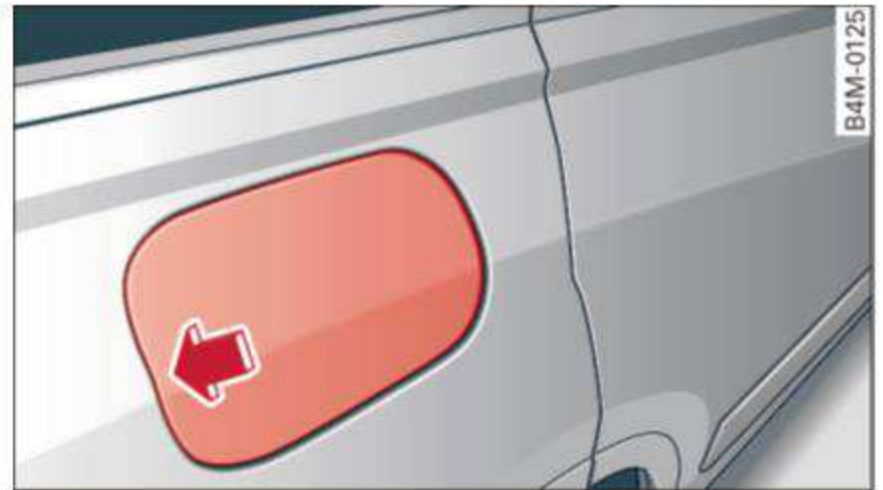

Fig. 253 Right rear side of the vehicle: opening the fuel filler door



Fig. 254 Fuel filler door with attached fuel cap

The fuel filler door is unlocked or locked by the central locking system.

- ▶ Press on the left side of the fuel filler door to open ⇒ *fig. 253*.
- ▶ Unscrew the tank cap counterclockwise.
- ▶ Place the cap from above on the open fuel filler door ⇒ *fig. 254*.
- ▶ Insert the fuel pump nozzle all the way into the fuel filler neck.
- ▶ Begin fueling. Once the fuel pump nozzle turns off the first time, the fuel tank is full. Do not continue fueling, or else the expansion space in the tank will be filled with fuel.
- ▶ After the fuel pump has switched off, wait five seconds before removing it to allow the rest of the fuel to finish dripping into the fuel tank.
- ▶ Turn the fuel cap clockwise until you hear it lock.
- ▶ Close the fuel filler door and then press on the left side until it latches.

The correct fuel type for your vehicle can be found on a label located on the inside of the fuel ▶

filler door. For additional information on fuel, see ⇒ *page 310*.

For the tank capacity in your vehicle, refer to the Technical Data ⇒ *page 369*.

To reduce the risk of fuel leaking out or vapors escaping, make sure that the fuel tank is closed correctly. Otherwise the  indicator light will turn on.

If the central locking system malfunctions, the fuel filler door may emergency release ⇒ *page 313*.

### **WARNING**

An improper fueling procedure and improper handling of fuel can lead to explosions, fires, severe burns and other injuries.

- Do not smoke and keep away from open flames.
- The ignition must be switched off when refueling.
- Cell phones, radio devices and other radio equipment should always be switched off when refueling. Electromagnetic rays could cause sparks and start a fire.
- If you do not insert the fuel pump nozzle all the way into the filler tube, then fuel can leak out. Spilled fuel can ignite and start a fire.
- Never get into the vehicle when refueling. If there is an exceptional situation where the vehicle must be entered, close the door and touch a metal surface before touching the fuel pump nozzle again. This will reduce the risk of electrostatic discharge that can cause flying sparks. Sparks can start a fire when refueling.

### **WARNING**

We recommend that you do not transport any fuel containers in the vehicle. Fuel could leak out of the container and ignite, especially during an accident. This can cause explosions, fires and injuries.

- If you must transport fuel in a fuel container, please note the following:

- Always place a fuel container on the ground before filling. Never fill the fuel container with fuel while it is in or on the vehicle. Electrostatic charge can occur while refueling and the fuel vapors could ignite.
- For fuel containers made of metal, the fuel pump nozzle must always maintain contact with the container to reduce the risk of static charge.
- Insert the fuel pump nozzle as far as possible into the filler opening while refueling.
- Follow legal requirements when using, storing and transporting fuel containers.
- Make sure that the fuel container meets the industry standards, for example ANSI or ASTM F852-86.

### **Note**

- Remove fuel that has overflowed onto any vehicle components immediately to reduce the risk of damage to the vehicle.
- Never drive until the fuel tank is completely empty. The irregular supply of fuel that results from that can cause engine misfires. Uncombusted fuel will enter the exhaust system and increase the risk of damage to the catalytic converter.

### **For the sake of the environment**

Do not overfill the fuel tank, otherwise fuel can leak out when the vehicle is warming up.

### **Tips**

The fuel filler door on your vehicle does not lock if you lock the vehicle from the inside using the central locking switch.

### Fuel filler door emergency release

If the central locking system is faulty, the fuel filler door can be unlocked manually.



Fig. 255 Right side trim panel in the luggage compartment: opening the trim panel



Fig. 256 Luggage compartment: fuel filler door emergency release

The emergency opening mechanism is located behind the right side trim panel in the luggage compartment.

- ▶ Open the cover in the side panel ⇒ *fig. 255*.
- ▶ Loosen the loop from the retainer and then pull on the loop carefully ⇒ *fig. 256* ⇒ ⚠. The filler door is released.
- ▶ Press on the left side of the fuel filler door to open it ⇒ *page 311, fig. 253*.

#### ⚠ Note

Only pull on the loop until you feel resistance. You will not hear it release. Otherwise you could damage the emergency release mechanism.

## Emissions control system

### Catalytic converter

The vehicle may only be driven with unleaded gasoline, otherwise the catalytic converter will be destroyed.

Never drive until the tank is completely empty. The irregular supply of fuel that results from that can cause engine misfires. Uncombusted fuel will enter the exhaust system, which can cause overheating and damage to the catalytic converter.

#### ⚠ WARNING

The temperature of the exhaust system is high, both when driving and after stopping the engine.

- Never touch the exhaust tail pipes once they have become hot. This could result in burns.
- Do not park your vehicle over flammable materials such as grass or leaves because the high temperature of the emissions control system could start a fire.
- Do not apply underbody protectant in the exhaust system area, because this increases the risk of fire.

## On Board Diagnostic System (OBD)

The On-Board Diagnostic System monitors the engine and transmission components that influence emissions.



Fig. 257 Footwell on left side of the vehicle: connection port for the On-Board Diagnostic System (OBD)

### On-Board Diagnostic System

Engine data can be read out at the On-Board Diagnostic System connection port using a special testing device ⇒ *fig. 257*.

### Indicator light

If the  indicator light blinks or turns on, there is a malfunction that is causing poor emissions quality and that could damage the catalytic converter.

Drive slowly to an authorized Audi dealer or authorized Audi Service Facility to have the malfunction corrected.

The indicator light can also turn on if the fuel filler cap is not closed correctly ⇒ *page 311*.

#### WARNING

Incorrect use of the connection port for the On-Board Diagnostic System can cause malfunctions, which can then result in accidents and serious injuries.

- Only allow an authorized Audi dealer or authorized Audi Service Facility to read out the engine data.

## Engine compartment

### Working in the engine compartment

*Special care is required if you are working in the engine compartment*

**For work in the engine compartment such as checking and filling fluids, there is a risk of injury, scalding, accidents, and burns. For this reason, follow all the warnings and general safety precautions provided in the following information. The engine compartment is a dangerous area. ⇒ .**

#### WARNING

- Turn the engine off.
- Switch the ignition off.
- Set the parking brake.
- Select the "P" selector lever position.
- Let the engine cool down.

- Never open the hood when there is steam or coolant escaping from the engine compartment, because there is a risk that you could be burned. Wait until no steam or coolant is escaping.
- Keep children away from the engine compartment.
- Never spill fluids on a hot engine. These fluids (such as the anti-freezing agent contained in the coolant) can ignite.
- Avoid short circuits in the electrical system.
- When working in the engine compartment, remember that the radiator fan can switch on even if the ignition is switched off, which increases the risk of injury.
- Never open the cap on the coolant expansion tank when the engine is warm. The cooling system is under pressure.
- To protect your face, hands, and arms from hot steam or coolant, cover the cap with a large cloth when opening.
- Do not remove the engine cover under any circumstances. This increases the risk of burns.
- If tests need to be performed with the engine running, there is additional danger due to moving components (such as the ribbed belt, alternator and radiator fan) and from the high-voltage ignition system.
- Do not under any circumstances activate the throttle inadvertently (for example, by hand from the engine compartment) if the vehicle is stationary but the engine is running and a gear is engaged. Otherwise, the vehicle will start to move immediately and this could result in an accident.
- Pay attention to the following warnings when work on the fuel system is required:
  - Do not smoke.
  - Never work near open flames.
  - Always have a working fire extinguisher nearby.
- All work on the battery or electrical system in your vehicle can result in injuries, chemical burns, accidents or burns. Because of this, all work must be performed **only** by an authorized Audi dealer or authorized Audi Service Facility.

- To reduce the risk of electric shock and injury, never touch the following components when the engine is running or is being started:
  - Ignition cable
  - Other components in the electronic high-voltage ignition system
- If you must check or perform work on the engine while it is running:
  - Set the parking brake first and then select the "P" selector lever position.
  - Always proceed with extreme caution so that clothing, jewelry or long hair do not become caught in the radiator fan, fan belt or other moving components or do not come into contact with hot components. Tie back long hair before beginning work and do not wear clothing that can hang down into the engine.
  - Limit your exposure to exhaust and chemicals to as short a time as possible ⇒ ⚠.

**⚠ WARNING**

California Proposition 65 Warning:

- Engine exhaust, some of its constituents, and certain vehicle components contain or emit chemicals known to the State of California to cause cancer and birth defects and reproductive harm. In addition, certain fluids contained in vehicles and certain products of component wear contain or emit chemicals known to the State of California to cause cancer and birth defects or other reproductive harm.
- Battery posts, terminals and related accessories contain lead and lead compounds, chemicals known to the State of California to cause cancer and reproductive harms. Wash hands after handling.

**! Note**

When filling fluids, be sure not to mix the fluids up. Otherwise severe malfunctions and engine damage will occur.

**🌿 For the sake of the environment**

You should regularly check the ground under your vehicle in order to detect leaks quickly. If there are visible spots from oil or other fluids, bring your vehicle to an authorized Audi dealer or authorized Audi Service Facility to be checked.

**Opening/closing the hood**

*The hood is released from inside the vehicle.*



Fig. 258 Driver footwell: release lever



Fig. 259 Unlocked hood: lever

Make sure the wiper arms are not raised up from the windshield. Otherwise the paint could be damaged.

**Opening the hood**

- ▶ With the driver's door open, pull the lever below the instrument panel in the direction of the arrow ⇒ fig. 258.
- ▶ Raise the hood slightly ⇒ ⚠.
- ▶ Press the lever ⇒ fig. 259 in the direction of the arrow. This releases the hooks.
- ▶ Open the hood.

### Closing the hood

- ▶ Push the hood down until you override the force of the struts.
- ▶ Let the hood fall lightly into the latch. *Do not press it in.* ⇒ ⚠.

#### ⚠ WARNING

- Never open the hood when there is steam or coolant escaping from the engine compartment, because there is a risk that you could be burned. Wait until no steam or coolant is escaping.

- For safety reasons, the hood must always be latched securely while driving. Because of this, always check the hood after closing it to make sure it is latched correctly. The hood is latched if the front corners cannot be lifted.
- If you notice that the hood is not latched while you are driving, stop immediately and close it, because driving when the hood is not latched increases the risk of an accident.
- If the hood is not latched completely, it could fly up while you are driving and obstruct your vision.

### Engine compartment overview

The most important check points.

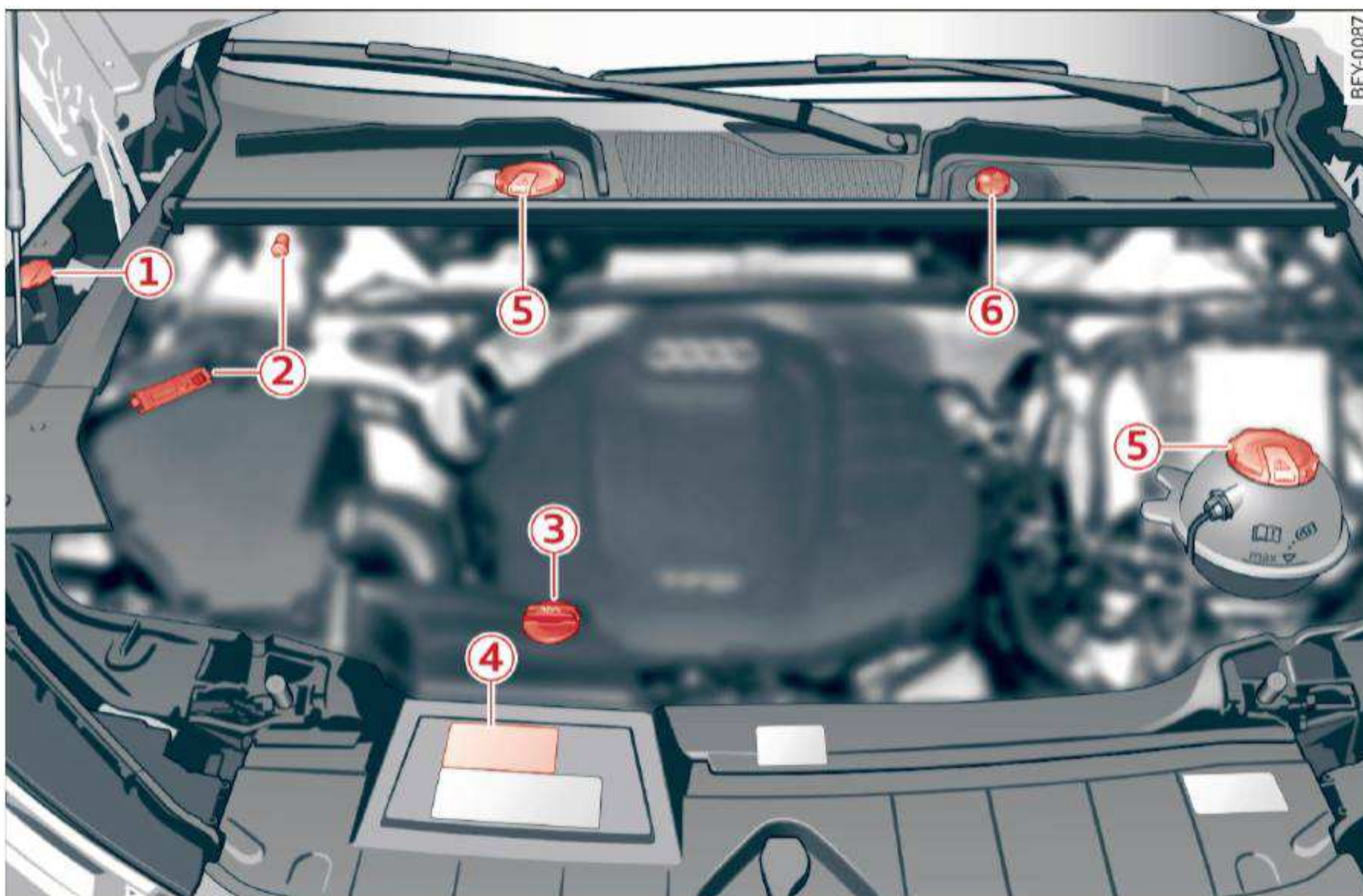

Fig. 260 Typical location of the reservoir and the engine oil filler opening

- ① Washer fluid reservoir (☞) ⇒ page 323
- ② Jump start point (+) under a cover, (-) with hex head screw ⇒ page 323 ⇒ page 363
- ③ Engine oil filler opening (☞) ⇒ page 317
- ④ Engine oil label\* with VW standard ⇒ page 317
- ⑤ Coolant expansion tank (☞) ⇒ page 320

- ⑥ Brake fluid reservoir (☞) ⇒ page 321

The location of the engine oil filling opening ③ and the coolant expansion tank ⑤ ⇒ fig. 260 may differ depending on the engine version. ▶

**! WARNING**

Read and follow all WARNINGS before checking anything in the engine compartment  
⇒ page 314.

## Engine oil

### If the engine oil level is too low

**If you need to add engine oil, use an oil that is listed on the sticker.** The sticker is located at the front of the engine compartment ⇒ page 316, fig. 260.

If the recommended engine oil is not available, **in an emergency** you may add a maximum of 1 quart (1 liter) of ACEA C3 or API SN engine oil **one time** until the next oil change.

For more information on the correct engine oil for your vehicle, contact an authorized Audi dealer or authorized Audi Service Facility. Have the oil changed by an authorized Audi dealer or authorized Service Facility.

**Audi recommends**

**Audi recommends using the Long Life high-performance engine oil from Audi Genuine Parts.**

### Checking the engine oil level

*The engine oil level can be checked in the Infotainment system*

Observe the safety precautions ⇒  in *Working in the engine compartment* on page 314.

- ▶ Park your vehicle on a level surface.
- ▶ Shut the engine off when it is warm.
- ▶ Switch only the ignition back on.
- ▶ Wait approximately two minutes.
- ▶ Select in the Infotainment system: the MENU button > **Vehicle** > left control button > **Service & checks** > **Oil level**.
- ▶ Read the oil level in the display. Add engine oil if the bar in the oil level indicator is just before “min” ⇒ page 318.

**! Note**

The engine oil level must not be under the “min” marking, as this will increase the risk of engine damage.

**i Tips**

The oil level indicator in the display is only an informational display. If the oil level is too low, a minimum oil warning appears in the instrument cluster. Add oil and close the hood. The current oil level is displayed in the Infotainment system the next time the ignition is switched on.

**i Tips**

The engine oil consumption may be up to 0.5 quart/600 miles (0.5 liter/1,000 km), depending on driving style and operating conditions. Consumption may be higher during the first 3,000 miles (5,000 km). Because of this, the engine oil level must be checked regularly. It is best to check each time you refuel your vehicle and before long drives.

- In order to provide effective lubrication and cooling of internal engine components, all internal combustion engines consume a certain amount of oil. Oil consumption varies from engine to engine and may change significantly over the life of the engine. Typically, engines with a specified break-in period consume more oil during the break-in period than they consume after oil consumption has stabilized.
- Under normal conditions, the rate of oil consumption depends on the quality and viscosity of the oil, the RPM (revolutions per minute) at which the engine is operated, the ambient temperature and road conditions. Further factors are the amount of oil dilution from water condensation or fuel residue and the oxidation level of the oil. As any engine is subject to wear as mileage builds up, the oil consumption may increase over time until replacement of worn components may become necessary.

- With all these variables coming into play, no standard rate of oil consumption can be established or specified. There is no alternative to checking the oil level regularly and frequently.
- If you have the impression your engine consumes excessive amounts of oil, we recommend that you consult an authorized Audi dealer to have the cause of your concern properly diagnosed. Keep in mind that the accurate measurement of oil consumption requires great care and may take some time. An authorized Audi dealer has instructions about how to measure oil consumption accurately.
- You can find information on engine oil and engine oil capacities for the USA at [www.audiusa.com/help/maintenance](http://www.audiusa.com/help/maintenance), or for Canada at [www.audi.ca/ca/web/en/customer-area/care-and-maintenance/audi-service-schedules.html](http://www.audi.ca/ca/web/en/customer-area/care-and-maintenance/audi-service-schedules.html), or call 800-822-2834.

### Adding engine oil



Fig. 261 Engine compartment: engine oil filler opening cover

Observe the safety precautions ⇒  in *Working in the engine compartment* on page 314.

- ▶ Turn the engine off.
- ▶ Open the hood ⇒ page 315.
- ▶ Unscrew the cap  for the engine oil filler opening ⇒ fig. 261.
- ▶ Carefully add 0.5 quart (0.5 liter) of the correct oil ⇒ page 317.
- ▶ Close the engine oil filler opening cap.
- ▶ Close the hood.

- ▶ Restart the ignition after two minutes and read the current oil level in the Infotainment system ⇒ page 317, *Checking the engine oil level*.
- ▶ Add more oil if necessary.

### WARNING

- When adding oil, do not let oil drip onto hot engine components. This increases the risk of a fire.
- You must seal the cap on the oil filler opening correctly so that oil does not leak out onto the hot engine and exhaust system when the engine is running, because this is a fire hazard.
- Always clean skin thoroughly if it comes into contact with engine oil.
- Engine oil is poisonous and must be kept out of reach of children.
- Store the engine oil securely in the original container.

### Note

- If the message  **Please reduce oil level** appears, there is too much oil in the engine and there is a risk of catalytic converter and engine damage. Do not start the engine. Contact an authorized Audi dealer or authorized Audi Service Facility to have excess engine oil extracted if necessary.
- Your Limited New Vehicle Warranty does not cover damage or malfunctions due to failure to follow recommended maintenance and use requirements as set forth in the Audi Owner's Manual and Warranty & Maintenance booklet.
- Use only a high quality engine oil that expressly complies with the Audi oil quality standard specified for your vehicle's engine. Using any other oil can cause serious engine damage.
- Do not mix any additional lubricants into the engine oil. Damage caused by such additives is not covered by the warranty.

### For the sake of the environment

- Oil should never enter the sewer system or come into contact with the ground.

- Pay attention to legal requirements when disposing of empty oil containers.

### Changing the engine oil

We recommend that have your oil changed by an authorized Audi dealer or a qualified service station.

Before you check anything in the engine compartment, **always read and heed all WARNINGS** ⇨  in Working in the engine compartment on page 314.

The engine oil must be changed according to the intervals specified in your Warranty & Maintenance booklet. This is very important because the lubricating properties of oil diminish gradually during normal vehicle use.

Under some circumstances the engine oil should be changed more frequently. Change oil more often if you drive mostly short distances, operate the vehicle in dusty areas or under predominantly stop-and-go traffic conditions, or have your vehicle where temperatures remain below freezing for extended periods.

Detergent additives in the oil will make fresh oil look dark after the engine has been running for a short time. This is normal and is not a reason to change the oil more often than recommended.

Because of the problem of proper disposal, along with the special tools and necessary expertise required, we strongly recommend that you have your oil changed by an authorized **Audi dealer** or a qualified service station.

**If you choose to change your oil yourself**, please note the following important information:

#### **WARNING**

- To reduce the risk of personal injury if you must change the engine oil in your vehicle yourself:
- Wear eye protection.
  - To reduce the risk of burns from hot engine oil, let the engine cool down to the touch.
  - When removing the oil drain plug with your fingers, stay as far away as possible. Always

keep your forearm parallel to the ground to help prevent hot oil from running down your arm.

- Drain the oil into a container designed for this purpose, one large enough to hold at least the total amount of oil in your engine.
- Engine oil is poisonous. Keep it well out of the reach of children.
- Continuous contact with used engine oil is harmful to your skin. Always protect your skin by washing oil off thoroughly with soap and water.

#### **Note**

Never mix oil additives with your engine oil. These additives can damage your engine and adversely affect your Audi Limited New Vehicle Warranty.

#### **For the sake of the environment**

- Before changing your oil, first make sure you know where you can properly dispose of the used oil.
- Always dispose of used engine oil properly. Do not dump it on garden soil, wooded areas, into open streams or down sewage drains.
- Recycle used engine oil by taking it to a used engine oil collection facility in your area, or contact a service station.

## Cooling system

### Coolant

The engine cooling system is filled with a mixture of purified water and coolant additive at the factory. This coolant must not be not changed.

The coolant level is monitored through the  indicator light ⇨ page 23. However, we do recommend occasionally checking the coolant level manually.

If you must add coolant, use a mixture of water and coolant additive. Mixing the coolant additive with distilled water is recommended. ▶

### Coolant additive

The coolant additive is made of anti-freezing and corrosion protection agents. Only use the following coolant additives. These additives may be mixed with each other.

Coolant additive	Specification
G12evo	TL 774 L
G12++	TL 774 G
G13	TL 774 J

The amount of coolant additive that needs to be mixed with water depends on the climate where the vehicle will be operated. If the coolant additive percentage is too low, the coolant can freeze and damage the engine.

	Coolant additive	Freeze protection
Warm regions	min. 40%	min. -13 °F (-25 °C)
	max. 45%	
Cold regions	min. 50%	max. -40 °F (-40 °C)
	max. 55%	

#### Note

- Before the start of winter, have an authorized Audi dealer or authorized Audi Service Facility check if the coolant additive in your vehicle matches the percentage appropriate for the climate. This is especially important when driving in colder climates.
- If the appropriate coolant additive is not available in an emergency, do not add any other additive. You could damage the engine. If this happens, only use water and restore the correct mixture ratio with the specified coolant additive as soon as possible.
- Only refill with new coolant.
- Radiator sealant must not be mixed with the coolant.

### Adding coolant

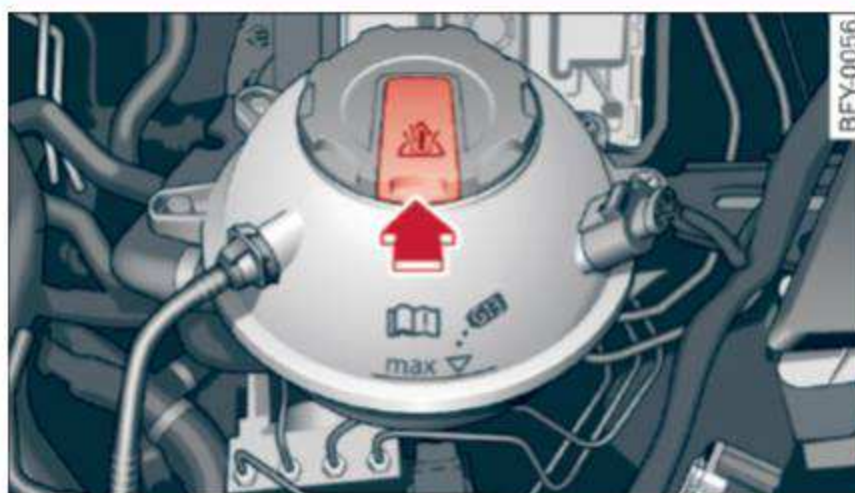



Fig. 262 Engine compartment: release button on coolant expansion tank

Observe the safety precautions ⇒ *page 314, Working in the engine compartment.*

### Checking the engine coolant level

- ▶ Park the vehicle on a level surface.
- ▶ Switch the ignition off.
- ▶ Read the coolant level on the coolant expansion tank ⇒ *fig. 262.*
- ▶ The coolant level must be between the MIN and MAX markings when the engine is cold. When the engine is warm it can be slightly above the MAX marking.

### Adding coolant

Requirement: there must be a residual amount of coolant in the expansion tank ⇒ .

- ▶ Let the engine cool down.
- ▶ Place a cloth over the coolant expansion tank cap.
- ▶ Push the release button ⇒ *fig. 262* and carefully unscrew the cap to the left until you feel resistance ⇒ .
- ▶ Push the release button again and remove the cap completely.
- ▶ Add coolant mixed in the correct ratio ⇒ *page 319* up to the MAX marking.
- ▶ Make sure that the fluid level remains stable. Add more coolant if necessary.
- ▶ Turn the cap to the right to secure it until you feel resistance a second time.

Coolant loss usually indicates there is a leak. Immediately drive your vehicle to an authorized Audi dealer or authorized Audi Service Facility and have the cooling system inspected. If the

cooling system is not leaking, a loss can come from the coolant boiling through overheating and being pushed out of the cooling system.

**! WARNING**

- The cooling system is under pressure. Do not open the coolant expansion tank cap when the engine is hot. This increases the risk of burns.
- The coolant additive and the coolant can be dangerous to your health. For this reason, keep the coolant in the original container and away from children. There is a risk of poisoning.
- When working in the engine compartment, remember that the radiator fan can switch on even if the ignition is switched off, which increases the risk of injury.

**! Note**

Do not add coolant if the expansion tank is empty. There may be air in the cooling system, which increases the risk of engine damage. If this is the case, do not continue driving. See an authorized Audi dealer or authorized Audi Service Facility for assistance.

## Brake fluid



Fig. 263 Engine compartment: cap on brake fluid reservoir

Observe the safety precautions ⇒ **!** in *Working in the engine compartment* on page 314.

### Checking the brake fluid level

- ▶ Read the brake fluid level on the brake fluid reservoir ⇒ page 316, fig. 260. The brake fluid level must be between the MIN and MAX markings ⇒ **!**.

The brake fluid level is monitored automatically.

### Changing the brake fluid

Have the brake fluid changed regularly by an authorized Audi dealer or authorized Audi Service Facility.

**! WARNING**

- If the brake fluid level is below the MIN marking, it can impair the braking effect and driving safety, which increase the risk of an accident. Do not continue driving. See an authorized Audi dealer or authorized Audi Service Facility for assistance.
- If the brake fluid is old, bubbles may form in the brake system during heavy braking. This would impair braking performance and driving safety, which increases the risk of an accident.
- To ensure the brake system functions correctly, only use brake fluids that comply with VW standard 501 14 or FMVSS-116 DOT 4.

**! Note**

- If the brake fluid level is above the MAX marking, brake fluid may leak out over the edge of the reservoir and result in damage to the vehicle.
- Do not get any brake fluid on the vehicle paint, because it will corrode the paint.







## Battery

### General warnings about batteries

Because of the complex power supply, all work on batteries such as disconnecting, replacing, etc., should **only** be performed by an authorized Audi dealer or authorized Audi Service Facility ⇒ **!**.

The term "vehicle battery" refers to the 12 Volt battery in your vehicle. ▶

### Detailed warnings for the vehicle battery:

	Always wear eye protection.
	Battery acid is highly corrosive. Always wear protective gloves and eye protection.
	Fire, sparks, open flame and smoking are forbidden.
	A highly explosive mixture of gases can form when charging batteries.
	Always keep children far away from battery electrolyte and the battery.
	Always follow the instructions in the operating manual.

#### **WARNING**

All work on the battery or electrical system in your vehicle can result in injuries, chemical burns, accidents or burns. Because of this, all work must be performed **only** by an authorized Audi dealer or authorized Audi Service Facility.

#### **WARNING**

California Proposition 65 Warning:  
 – Battery posts, terminals and related accessories contain lead and lead compounds, chemicals known to the State of California to cause cancer and reproductive problems. Wash hands after handling.

#### **Note**

- If the vehicle will be parked for long periods of time, protect it against the cold so that it will not be destroyed by “freezing”  
 ⇒ *page 323*.
- There are electrical components under the cargo floor behind a trim panel that warm up during operation. To reduce the risk of the components overheating, do not store objects such as blankets under the cargo floor. If they overheat, the components will switch off temporarily. This will be indicated by a message in the instrument cluster, until the temperature returns to normal.

#### **For the sake of the environment**

- ✗ Batteries contain polluting substances such as sulfuric acid and lead. Contact an authorized Audi dealer or authorized Audi Service Facility for more information.

#### **Vehicle battery**

*The term “vehicle battery” refers to the 12 Volt battery in your vehicle.*

#### **Not running the vehicle for long periods of time**

If you do not drive your vehicle for several days or weeks, electrical equipment is gradually scaled back or switched off. This reduces energy use and ensures the vehicle will be able to start after long periods of time ⇒ *page 145*. Some convenience functions, such as interior lighting or power seat adjustment, may not be available under certain circumstances. These convenience functions will be available again once you switch the ignition on and start the engine.

Even when electrical equipment is switched off, the equipment can still drain the vehicle battery if the vehicle is not driven for long periods of time. Deep draining results in a chemical reaction that destroys the inside of the vehicle battery. The vehicle battery must be charged every month to reduce the risk of this happening ⇒ *page 323*. Contact an authorized Audi dealer or authorized Audi Service Facility for more information.

#### **Winter operation**

Cold weather places higher demands on the vehicle battery. This results in reduced starting ability. Have the vehicle battery checked by an authorized Audi dealer or authorized Audi Service Facility before the cold time of year.

**Charging the vehicle battery**

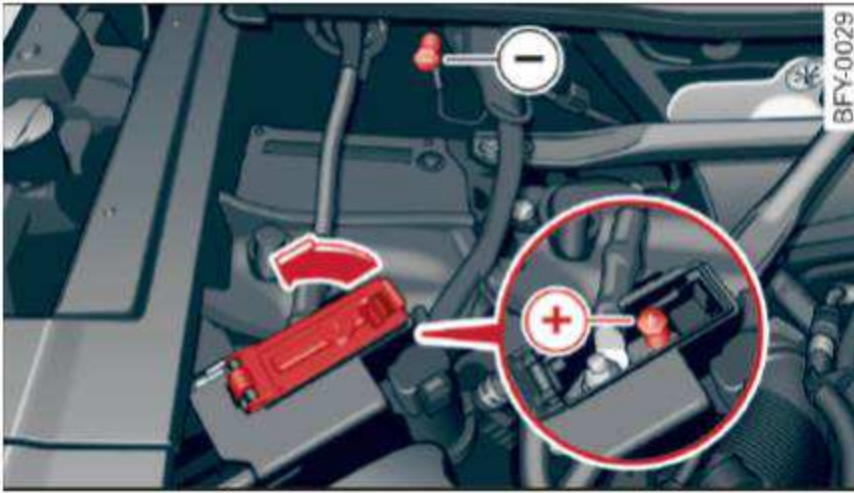

**Fig. 264** Engine compartment: connectors for a charger and jump start cables

Requirement: only use chargers with a **maximum charging voltage of 30 amps/14.8 Volts**. The vehicle battery cables remain connected.

- ▶ Read the warnings ⇒ ⚠ in *General warnings about batteries on page 322* and ⇒ ⚠.
- ▶ Switch off the ignition and all electrical equipment.
- ▶ Open the hood ⇒ *page 315*.
- ▶ Open the red cover on the positive terminal ⇒ *fig. 264*.
- ▶ Clamp the charger terminal clamps to the **jump start pins** according to the instructions. (pin under the red cover = “positive”, pin with hexagonal head = “negative”).
- ▶ Insert the power cable for the charging device into the socket and switch the device on.
- ▶ At the end of the charging process, switch the charger off and pull the power cable out of the socket.
- ▶ Remove the charger terminal clamps.
- ▶ Close the red cover on the positive terminal.
- ▶ Close the hood ⇒ *page 315*.

**⚠ WARNING**

- A highly explosive mixture of gases can form when charging batteries. Only charge the vehicle battery in well-ventilated areas.
- A drained vehicle battery can freeze at temperatures around 32 °F (0 °C). A frozen or thawed vehicle battery must not be charged and must not be used anymore. If ice forms, the battery housing can crack and battery electrolyte can leak out, which increases the risk of an explosion and chemical burns.

Contact an authorized Audi dealer or authorized Audi Service Facility for more information.

- Do not connect or disconnect the charging cable while charging because this increases the risk of an explosion.

**i Tips**

- Only charge the vehicle battery through the connections in the engine compartment.
- Read all of the manufacturer's instructions for the charger before charging the vehicle battery.

**Windshield washer system**



**Fig. 265** Engine compartment: washer fluid reservoir cap

The windshield washer fluid reservoir  contains the cleaning solution for the windshield and the headlight washer system\* ⇒ *page 316, fig. 260*. The reservoir capacity can be found in ⇒ *page 369*.

To reduce the risk of lime scale deposits on the spray nozzles, use clean water with low amounts of calcium. Always add window cleaner to the water. When the outside temperatures are cold, an anti-freezing agent should be added to the water so that it does not freeze.

**! Note**

- The concentration of anti-freezing agent must be adjusted to the vehicle operating conditions in the respective climate. A concentration that is too high can lead to vehicle damage.

- Never add radiator anti-freeze or other additives to the washer fluid.
- Do not use a glass cleaner that contains paint solvents, because this could damage the paint.

your vehicle, especially the engine. Even if the mileage on the vehicle is low, do not exceed the time for the next service.

## Service interval display

*The service interval display detects when your vehicle is due for service.*

### Checking service intervals

You can check the remaining distance or time until the next oil change or next inspection in the Infotainment system.

- ▶ Select in the Infotainment system: the **MENU** button > **Vehicle** > left control button > **Service & checks** > **Service intervals**.

### Resetting the indicator

An authorized Audi dealer or authorized Audi Service Facility will reset the service interval display after performing service.

If you have changed the oil yourself, you must reset the oil change interval.

- ▶ Select in the Infotainment system: the **MENU** button > **Vehicle** > left control button > **Service & checks** > **Service intervals** > **Reset oil change interval**.

If an oil change or inspection is due, you can access it in the Infotainment system. The display works in two stages:

- **Service reminder:** after a certain distance is driven, a message appears in the instrument cluster display every time the ignition is switched on. The remaining distance and time is displayed briefly.
- **Service due:** if your vehicle has reached a service interval, a message appears briefly after switching the ignition on.

### Note

- Only reset the oil change indicator if the oil was changed.
- Following the service intervals is critical to maintaining the service life and value of

## Wheels

### Wheels and Tires

#### General information

- ▶ Check your tires regularly for damage (punctures, cuts, cracks and bulges). Remove foreign objects from the tire tread.
- ▶ If driving over curbs or similar obstacles, drive slowly and approach the curb at an angle.
- ▶ Have faulty tires or rims replaced immediately.
- ▶ Protect your tires from oil, grease and fuel.
- ▶ Mark tires before removing them so that the same running direction can be maintained if they are reinstalled.
- ▶ Lay tires flat when storing and store them in a cool, dry location with as little exposure to light as possible.

#### WARNING

- Never drive faster than the maximum permitted speed for your tires. This could cause the tires to heat up too much. This increases the risk of an accident because it can cause the tire to burst.
- Always adapt your driving to the road and traffic condi-

tions. Drive carefully and reduce your speed on icy or slippery roads. Even winter tires can lose traction on black ice.

#### Note

- Please note that summer and winter tires are designed for the conditions that are typical in those seasons. Audi recommends using winter tires during the winter months. Low temperatures significantly decrease the elasticity of summer tires, which affects traction and braking ability. If summer tires are used in very cold temperatures, cracks can form on the tread bars, resulting in permanent tire damage that can cause loud driving noise and unbalanced tires.
- Burnished, polished or chromed rims must not be used in winter driving conditions. The surface of the rims does not have sufficient corrosion protection for this and could be permanently damaged by road salt or similar substances.

**Tire designations**

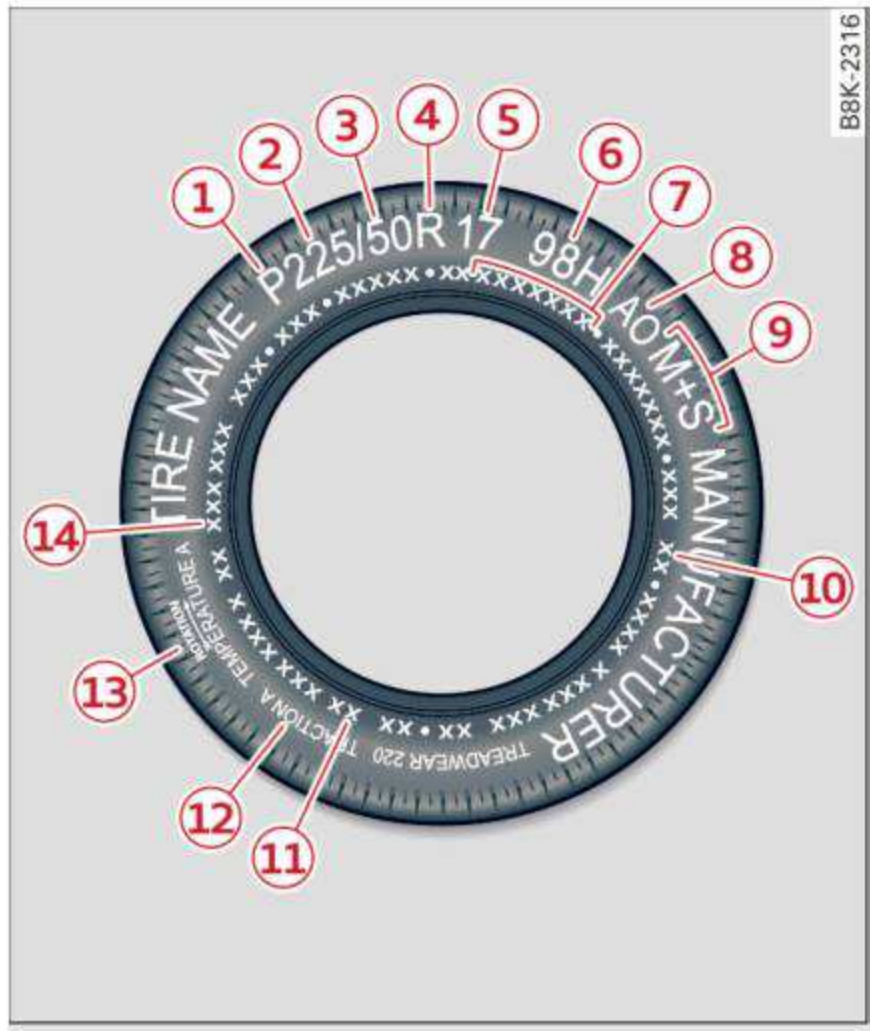

**Fig. 266** Tire designations on the sidewall

**① Tires for passenger vehicles (if applicable)**

"P" indicates a tire for a passenger vehicle. "T" indicates a tire designated for temporary use.

**② Nominal width**

Nominal width of the tire between the sidewalls in millimeters. In general: the larger the number, the wider the tire.

**③ Aspect ratio**

Height/width ratio expressed as a percentage.

**④ Tire construction**

"R" indicates a radial tire.

**⑤ Rim diameter**

Size of the rim diameter in inches.

**⑥ Load index and speed rating**

The load index indicates the tire's load-carrying capacity.

The speed rating indicates the maximum permitted speed. Also see ⇒ ⚠ in *General information on page 325*.

"EXTRA LOAD", "xl" or "RF" indicates that the tire is reinforced or is an Extra Load tire.

Speed rating	Maximum permitted speed
P	up to 93 mph (150 km/h)
Q	up to 99 mph (160 km/h)
R	up to 106 mph (170 km/h)
S	up to 110 mph (180 km/h)
T	up to 118 mph (190 km/h)
U	up to 124 mph (200 km/h)
H	up to 130 mph (210 km/h)
V	up to 149 mph (240 km/h) <sup>a)</sup>
Z	above 149 mph (240 km/h) <sup>a)</sup>
W	up to 168 mph (270 km/h) <sup>a)</sup>
Y	up to 186 mph (300 km/h) <sup>a)</sup>

<sup>a)</sup> For tires above 149 mph (240 km/h), tire manufacturers sometimes use the code "ZR".

### ⑦ US DOT number (TIN) and manufacture date

The manufacture date is listed on the tire sidewall (it may only appear on the inner side of the tire):

**DOT ... 2217 ...**

means, for example, that the tire was produced in the 22nd week of the year 2017.

### ⑧ Audi Original Tires

Audi Original equipment tires with the designation “AO” have been specially matched to your Audi. When used correctly, these tires meet the highest standards for safety and handling. An authorized Audi dealer or authorized Audi Service Facility will be able to provide you with more information.

### ⑨ Mud and snow capability

“M/S” or “M+S” indicates the tire is suitable for driving on mud and snow.  indicates a winter tire.

### ⑩ Composition of the tire cord and materials

The number of plies indicates the number of rubberized fabric layers in the tire. In general: the more layers, the more weight a tire can carry. Tire manufacturers

must also specify the materials used in the tire. These include steel, nylon, polyester and other materials.

### ⑪ Maximum permitted load

This number indicates the maximum load in kilograms and pounds that the tire can carry.

### ⑫ Uniform tire quality grade standards for treadwear, traction and temperature resistance

Treadwear, traction and temperature ranges ⇒ *page 341*.

### ⑬ Running direction

The arrows indicate the running direction of unidirectional tires. You must always follow the specified running direction ⇒ *page 355*.

### ⑭ Maximum permitted inflation pressure

This number indicates the maximum pressure to which a tire can be inflated under normal operating conditions.

## Glossary of tire and loading terminology

### **Accessory weight**

means the combined weight (in excess of those standard items which may be replaced) of automatic transmission, power steering, power brakes, power windows, power seats, radio, and heater, to the extent that these items are available as factory-installed equipment (whether installed or not).

### **Aspect ratio**

means the ratio of the height to the width of the tire in percent. Numbers of 55 or lower indicate a low sidewall for improved steering response and better overall handling on dry pavement.

### **Bead**

means the part of the tire that is made of steel wires, wrapped or reinforced by ply cords and that is shaped to fit the rim.

### **Bead separation**

means a breakdown of the bond between components in the bead.

### **Cord**

means the strands forming the plies in the tire.

### **Cold tire inflation pressure**

means the tire pressure recommended by the vehicle manufacturer for a tire of a designated size that has not been driven for more than a couple of miles (kilometers) at low speeds in the three hour period before the tire pressure is measured or adjusted.

### **Curb weight**

means the weight of a motor vehicle with standard equipment including the maximum capacity of fuel, oil, and coolant, air conditioning and additional weight of optional equipment.

### **Extra load tire**

means a tire designed to operate at higher loads and at higher inflation pressures than the corresponding standard tire. Extra load tires may be identified as “XL”, “xl”, “EXTRA LOAD”, or “RF” on the sidewall. ▶

**Gross Axle Weight Rating (“GAWR”)**

means the load-carrying capacity of a single axle system, measured at the tire-ground interfaces.

**Gross Vehicle Weight Rating (“GVWR”)**

means the maximum total loaded weight of the vehicle.

**Groove**

means the space between two adjacent tread ribs.

**Load rating (code)**

means the maximum load that a tire is rated to carry for a given inflation pressure. You may not find this information on all tires because it is not required by law.

**Maximum load rating**

means the load rating for a tire at the maximum permissible inflation pressure for that tire.

**Maximum loaded vehicle weight**

means the sum of:

- (a) Curb weight
- (b) Accessory weight
- (c) Vehicle capacity weight, and
- (d) Production options weight

**Maximum (permissible) inflation pressure**

means the maximum cold inflation pressure to which a tire may be inflated. Also called “maximum inflation pressure.”

**Normal occupant weight**

means 150 lbs. (68 kilograms) times the number of occupants seated in the vehicle up to the total seating capacity of your vehicle.

**Occupant distribution**

means distribution of occupants in a vehicle.

**Outer diameter**

means the overall diameter of an inflated new tire.

**Overall width**

means the linear distance between the exteriors of the sidewalls of an inflated tire, including elevations due to labeling, decorations, or protective bands or ribs.

**Ply**

means a layer of rubber-coated parallel cords. ▶

### **Production options weight**

means the combined weight of those installed regular production options weighing over 5 lbs.

(2.3 kg) in excess of those standard items which they replace, not previously considered in curb weight or accessory weight, including heavy duty brakes, ride levelers, roof rack, heavy duty battery, and special trim.

### **Radial ply tire**

means a pneumatic tire in which the ply cords that extend to the beads are laid at substantially 90 degrees to the centerline of the tread.

### **Recommended inflation pressure**

see ⇨ *page 328, Cold tire inflation pressure.*

### **Reinforced tire**

means a tire designed to operate at higher loads and at higher inflation pressures than the corresponding standard tire. Reinforced tires may be identified as “XL”, “xl”, “EXTRA LOAD”, or “RF” on the sidewall.

### **Rim**

means a metal support for a tire or a tire and tube assembly upon which the tire beads are seated.

### **Rim diameter**

means nominal diameter of the bead seat. If you change your wheel size, you will have to purchase new tires to match the new rim diameter.

### **Rim size designation**

means rim diameter and width.

### **Rim width**

means nominal distance between rim flanges.

### **Sidewall**

means that portion of a tire between the tread and bead.

### **Speed rating (letter code)**

means the speed at which a tire is designed to be driven for extended periods of time. The ratings range from 93 mph (150 km/h) to 186 mph (298 km/h) ⇨ *table on page 326.* You may not find this information on all tires because it is not required by law.

The speed rating letter code, where applicable, is molded on the tire sidewall and indicates the ►

maximum permissible road speeds. See also ⇒ [▲](#) in *General information on page 325*.

### **Tire pressure monitoring system**

means a system that detects when one or more of a vehicle's tires are underinflated and illuminates a low tire pressure warning telltale.

### **Tread**

means that portion of a tire that comes into contact with the road.

### **Tread separation**

means pulling away of the tread from the tire carcass.

### **Treadwear indicators (TWI)**

means the projections within the principal grooves designed to give a visual indication of the degrees of wear of the tread. See ⇒ *page 334, Treadwear indicator* for more information on measuring tire wear.

### **Uniform Tire Quality Grading**

is a tire information system developed by the United States National Highway Traffic Safety Administration (NHTSA) that is designed to help buyers make relative com-

parisons among tires. The UTQG is not a safety rating and not a guarantee that a tire will last for a prescribed number of miles (kilometers) or perform in a certain way. It simply gives tire buyers additional information to combine with other considerations, such as price, brand loyalty and dealer recommendations. Under UTQG, tires are graded by the tire manufacturers in three areas: treadwear, traction, and temperature resistance. The UTQG information on the tires, molded into the sidewalls.

### **U.S. DOT Tire Identification Number (TIN)**

This is the tire's "serial number". It begins with the letters "DOT" and indicates that the tire meets all federal standards. The next two numbers or letters indicate the plant where it was manufactured, and the last four numbers represent the week and year of manufacture. For example,

### **DOT ... 2217 ...**

means that the tire was produced in the 22nd week of 2017. The other numbers are marketing codes that may or may not be used ▶

by the tire manufacturer. This information is used to contact consumers if a tire defect requires a recall.

### **Vehicle capacity weight**

means the rated cargo and luggage load plus 150 lbs. (68 kilograms) times the vehicle's designated seating capacity.

### **Vehicle maximum load on the tire**

means that load on an individual tire that is determined by distributing to each axle its share of the maximum loaded vehicle weight and dividing by two.

### **Vehicle normal load on the tire**

means that load on an individual tire that is determined by distributing to each axle its share of the curb weight, accessory weight, and normal occupant weight (distributed in accordance with ⇒ *table on page 337*) and dividing by two.

### **Occupant loading and distribution for vehicle normal load for various designated seating capacities**

Refer to the tire inflation pressure label ⇒ *page 335, fig. 269*

for the number of seating positions. Refer to the table ⇒ *table on page 337* for the number of people that correspond to the vehicle normal load.

### **New tires or wheels**

Audi recommends having all work on tires or wheels performed by an authorized Audi dealer or authorized Audi Service Facility. These facilities have the proper knowledge and are equipped with the required tools and replacement parts.

- ▶ New tires do not yet have the optimum gripping properties. Drive carefully and at moderate speeds for the first 350 miles (500 km) with new tires.
- ▶ Only use tires with the same design, size (rolling circumference), and as close to the same tread pattern as possible on all four wheels.
- ▶ Do not replace tires individually. At least replace both tires on the same axle at the same time.
- ▶ Audi recommends that you use Audi Original Tires. If you would like to use different tires, please note that the tires may perform ▶

differently even if they are the same size ⇒ ⚠.

- ▶ If you would like to equip your vehicle with a tire/rim combination that is different from what was installed at the factory, consult with an authorized Audi dealer or authorized Audi Service Facility before making a purchase ⇒ ⚠.

Because the spare tire\* is different from the regular tires installed on the vehicle (such as winter tires or wide tires), only use the spare tire\* temporarily in case of emergency and drive carefully while it is in use. It should be replaced with a regular tire as soon as possible.

All four wheels must be equipped with tires that are the same brand and have the same construction and tread pattern so that the drive system is not damaged by different tire speeds. For this reason, in case of emergency, only use a spare tire\* that is the same circumference as the regular tires.

**⚠ WARNING**

–Do not use steel rims that are 17 inches or larger. Other-

wise, damage to the vehicle and an accident could result.

- Only use tire/rim combinations and suitable wheel bolts that have been approved by Audi. Otherwise, damage to the vehicle and an accident could result.
- For technical reasons, it is not possible to use tires from other vehicles - in some cases, you cannot even use tires from the same vehicle model.
- Make sure that the tires you select have enough clearance to the vehicle. Replacement tires should not be chosen simply based on the nominal size, because tires with a different construction can differ greatly even if they are the same size. If there is not enough clearance, the tires or the vehicle can be damaged and this can reduce driving safety and increase the risk of an accident.
- Only use tires that are more than six years old when absolutely necessary and drive carefully when doing so.
- Do not use run-flat tires on your vehicle. Using them when

not permitted can lead to vehicle damage or accidents.

- If you install wheel covers on the vehicle, make sure they allow enough air circulation to cool the brake system. If they do not, this could increase the risk of an accident.

### Tire wear/damage

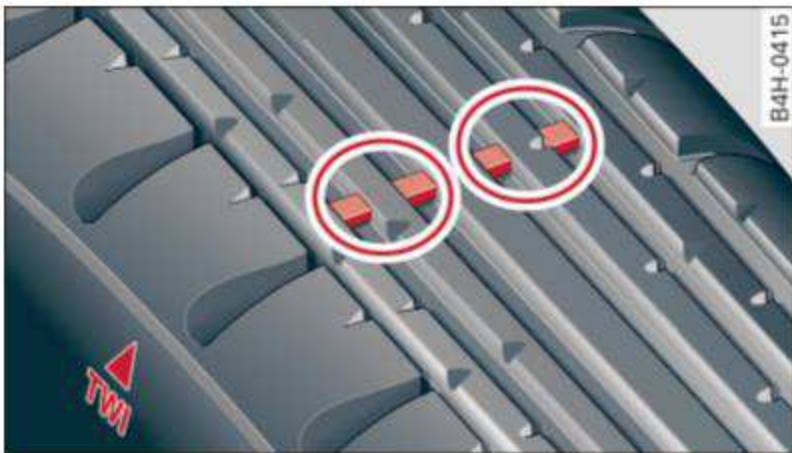

**Fig. 267** Tire profile: treadwear indicator

### Tire wear

Check the tires regularly for wear.

- Inflation pressure that is too low or high can increase tire wear considerably.
- Driving quickly through curves, rapid acceleration and heavy braking increase tire wear.
- Have an authorized Audi dealer or authorized Audi Service Facili-

ty check the wheel alignment if there is unusual wear.

- Have the wheels rebalanced if an imbalance is causing noticeable vibration in the steering wheel. If you do not, the tires and other vehicle components could wear more quickly.

### Treadwear indicator

Original equipment tires contain treadwear indicators in the tread pattern, which are bars that are 1/16 in (1.6 mm) high and are spaced evenly around the tire perpendicular to the running direction ⇒ *fig. 267*. The letters “TWI” or triangles on the tire sidewall indicate the location of the treadwear indicators.

The tires have reached the minimum tread depth <sup>1)</sup> when they have worn down to the treadwear indicators. Replace the tires with new ones ⇒ ⚠.

### Tire rotation

Rotating the tires regularly is recommended to ensure the tires wear evenly. To rotate the tires, install the tires from the rear axle ►

<sup>1)</sup> Obey any applicable regulations in your country.

on the front axle and vice versa. This will allow the tires to have approximately the same length of service life.

For unidirectional tires, make sure the tires are installed according to the running direction indicated on the tire sidewall

⇒ *page 355.*

### Hidden damage

Damage to tires and rims can often occur in locations that are hidden. Unusual vibrations in the vehicle or pulling to one side may indicate that there is tire damage. Reduce your speed immediately. Check the tires for damage. If no damage is visible from the outside, drive slowly and carefully to the nearest authorized Audi dealer or authorized Audi Service Facility to have the vehicle inspected.

#### WARNING

Tread that has worn too low or different tread depths on the tires can reduce driving safety. This can increase the risk of an accident because it has a negative effect on handling, driving through curves, and braking, and because it increases the

risk of hydroplaning when driving through deep puddles.

### Tire pressure

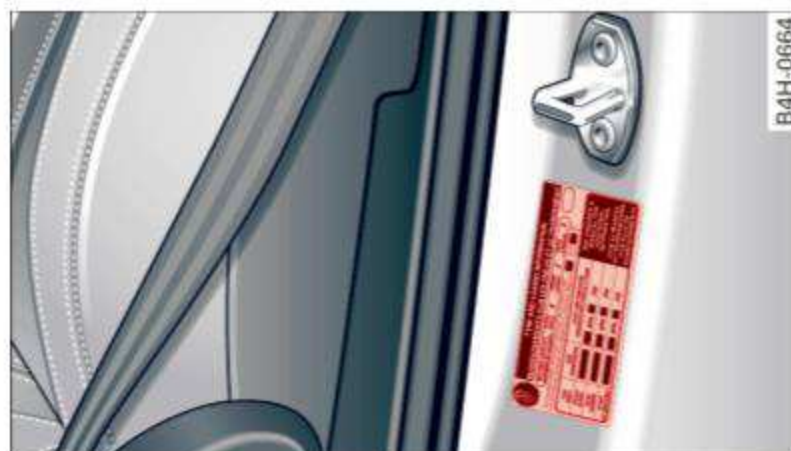

**Fig. 268** Driver's side B-pillar: tire pressure label

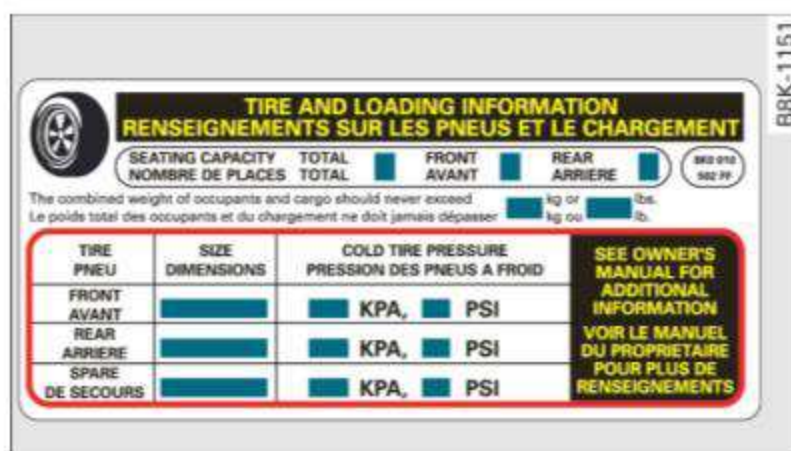

**Fig. 269** Tire pressure label

The correct tire pressure for tires installed at the factory is listed on a label. The label is located on the B-pillar ⇒ *fig. 268*, ⇒ *fig. 269*. The location may vary depending on the model.

Use the tire pressure specified for a normal vehicle load when the vehicle is partially loaded ⇒ *table on page 337*. If driving the vehicle when fully loaded, you must

increase the tire pressure to the maximum specified pressure ⇒ .

### Checking/correcting tire pressure

- ▶ Check the tire pressure at least once per month and also check it before every long drive.
- ▶ Always check the tire pressure when the tires are *cold*. Do not reduce the pressure if it increases when the tires are warm.
- ▶ Check the label ⇒ *fig. 269* for the correct tire pressure based on vehicle load.
- ▶ Correct the tire pressure if necessary.
- ▶ Store the new tire pressure in the Infotainment system ⇒ *page 343*.

 **WARNING**

Always adapt the tire pressure to your driving style and vehicle load.

–Overloading can lead to loss of vehicle control and increase

the risk of an accident. Read and follow the important safety precautions in ⇒ *page 337, Tires and vehicle load limits*.

- The tire must flex more if the tire pressure is too low or if the vehicle speed or load are too high. This heats the tire up too much. This increases the risk of an accident because it can cause the tire to burst and result in loss of vehicle control.
- Incorrect tire pressure increases tire wear and has a negative effect on driving and braking behavior, which increases the risk of an accident.

 **Note**

Replace lost valve caps to reduce the risk of damage to the tire valves.

 **For the sake of the environment**

Tire pressure that is too low increases fuel consumption.

## Tire pressure table

Please note that the information contained in the following table was correct at the time of printing, and the information is subject to change. If there are differ-

ences between this information and the tire pressures specified ▶

on the label on the driver's side B-pillar, always follow the specification on the B-pillar label

⇒ *page 335, fig. 268.*

Make sure that the tire designation on your tire matches the des-

ignation on the tire pressure label and the tire pressure table.

The following table lists recommended tire pressures in cold tires according to the load and the size of the tires installed.

Model/ Engine	Tire designation	Tire pressure							
		Normal load (up to 3 people) <sup>a)</sup>				Maximum load			
		front		rear		front		rear	
		PSI	kPA	PSI	kPA	PSI	kPA	PSI	kPA
Q5: 2.0L 4-cylinder gasoline engine	235/60 R18 103H	29	200	29	200	35	240	38	260
	235/55 R19 101H	29	200	29	200	33	230	36	250
	255/45 R20 101H	29	200	29	200	33	230	36	250
	255/45 R20 101W	29	200	29	200	32	220	35	240
	255/40 R21 102Y	32	220	32	220	32	220	35	240
SQ5: 3.0L 6-cylinder gasoline engine	255/45 R20 101H	33	230	30	210	36	250	36	250
	255/45 R20 101W	36	250	33	230	41	280	44	300
	255/40 R21 102Y	33	230	33	230	36	250	39	270

a) 2 people in the front, 1 person in the rear

### WARNING

Please note the important safety precautions regarding tire pressure ⇒ *page 335* and load limits ⇒ *page 337*.

## Tires and vehicle load limits

There are limits to the amount of load or weight that any vehicle and any tire can carry. A vehicle that is overloaded will not handle well and is more difficult to stop. Overloading can not only lead to

loss of vehicle control, but can also damage important parts of the vehicle and can lead to sudden tire failure, including a blowout and sudden deflation that can cause the vehicle to crash.

Your safety and that of your passengers also depends on making sure that load limits are not exceeded. Vehicle load includes everybody and everything in and on the vehicle. These load limits are technically referred to as the

## vehicle's **Gross Vehicle Weight Rating** ("GVWR").

The "GVWR" includes the weight of the basic vehicle, all factory installed accessories, a full tank of fuel, oil, coolant and other fluids plus maximum load. The maximum load includes the number of passengers that the vehicle is intended to carry ("seating capacity") with an assumed weight of 150 lbs. (68 kg) for each passenger at a designated seating position and the total weight of any luggage in the vehicle. If you tow a trailer, the weight of the trailer hitch and the tongue weight of the loaded trailer must be included as part of the vehicle load.

The **Gross Axle Weight Rating** ("GAWR") is the maximum load that can be applied at each of the vehicle's two axles.

The fact that there is an upper limit to your vehicle's Gross Vehicle Weight Rating means that the total weight of whatever is being carried in the vehicle (including the weight of a trailer hitch and the tongue weight of the loaded trailer) is limited. The more passengers in the vehicle or passen-

gers who are heavier than the standard weights assumed mean that less weight can be carried as luggage.

The Gross Vehicle Weight Rating and the Gross Axle Weight Rating are listed on the safety compliance sticker label located on the driver's side B-pillar.

### **WARNING**

Overloading a vehicle can cause loss of vehicle control, a crash or other accident, serious personal injury, and even death.

- Carrying more weight than your vehicle was designed to carry will prevent the vehicle from handling properly and increase the risk of the loss of vehicle control.
- The brakes on a vehicle that has been overloaded may not be able to stop the vehicle within a safe distance.
- Tires on a vehicle that has been overloaded can fail suddenly, including a blowout and sudden deflation, causing loss of control and a crash.
- Always make sure that the total load being transported –

including the weight of a trailer hitch and the tongue weight of a loaded trailer – does not make the vehicle heavier than the vehicle’s Gross Vehicle Weight Rating.

### Determining correct load limit

Use the example below to calculate the total weight of the passengers and luggage or other things that you plan to transport so that you can make sure that your vehicle will not be overloaded.

#### Steps for Determining Correct Load Limit

1. Locate the statement “THE COMBINED WEIGHT OF OCCUPANTS AND CARGO SHOULD NEVER EXCEED XXX KG OR XXX LBS” on your vehicle’s placard (tire inflation pressure label) ⇒ *page 335, fig. 269*.
2. Determine the combined weight of the driver and passengers that will be riding in your vehicle.
3. Subtract the combined weight of the driver and passengers from “XXX” kilograms or “XXX” pounds shown on the sticker ⇒ *page 335, fig. 269*.
4. The resulting figure equals the available amount of cargo and luggage load capacity. For example, if the “XXX” amount equals 1400 lbs. and there will be five 150 lbs. passengers in your vehicle, the amount of available cargo and luggage load capacity is 650 lbs. (1400-750 (5 x 150) = 650 lbs.)
5. Determine the combined weight of luggage and cargo being loaded on the vehicle. That weight may not safely exceed the available cargo and luggage load capacity calculated in Step 4.
6. If your vehicle will be towing a trailer, load from your trailer will be transferred to your vehicle. Consult this manual to determine how this reduces the available cargo and luggage load capacity of your vehicle.
  - ▶ Check the tire sidewall (⇒ *page 326, fig. 266*) to determine the designated load rating for a specific tire.

### Wheel bolts and rims

#### Wheel bolts

Wheel bolts must be clean and loosen/tighten easily.

#### Rims

Rims with a bolted rim ring\* or with bolted wheel covers\* consist of multiple pieces. These components were bolted together using special bolts and a special procedure. You must not repair or disassemble them ⇒ ⚠.

#### ⚠ WARNING

Wheel bolts that are tightened or repaired incorrectly can become loose and result in loss of vehicle control, which increases the risk of an accident. For the correct tightening specification, see ⇒ *page 356, Finishing*.

- Always keep the wheel bolts and the threads in the wheel hub clean and free of grease.
- Only use wheel bolts that fit the rim.
- Always have damaged rims repaired by an authorized Audi dealer or authorized Audi Service Facility. Never repair or disassemble rims yourself, because this increases the risk of an accident.

### Winter tires

Winter tires significantly improve the vehicle's handling when driving in winter conditions. Because of their construction (width, compound, tread pattern), summer tires provide less traction on ice and snow.

- ▶ Use winter tires on all four wheels.
- ▶ Only use winter tires that are approved for your vehicle.
- ▶ Please note that the maximum permitted speed may be lower with winter tires ⇒ ⚠ *in General information on page 325*. An authorized Audi dealer or authorized Audi Service Facility can inform you about the maximum permitted speed for your tires.
- ▶ Check the tire pressure after installing wheels ⇒ *page 335*.

The effectiveness of winter tires is reduced greatly when the tread is worn down to a depth of 0.16 in (4 mm). The characteristics of winter tires also decrease greatly as the tire ages, regardless of the remaining tread.



#### For the sake of the environment

Reinstall summer tires at the appropriate time, because they provide better handling when roads are free of snow and ice. Summer tires cause less road noise, tire wear and fuel consumption.



#### Tips

You can also use all season tires instead of winter tires. Please note that in some countries where winter tires are required, only winter tires with the ⚠ symbol may be permitted.

### Snow chains

Snow chains not only improve the driving in winter road conditions, but also the braking.

- ▶ Only install snow chains on the *rear* wheels.
- ▶ Check and correct the seating of the snow chains after driving a few feet, if necessary. Follow the instructions from the manufacturer.
- ▶ Note the maximum speed of 30 mph (50 km/h). Note the local regulations.

Use of snow chains is only permitted with certain rim/tire combinations due to technical reasons. Check with an authorized Audi dealer or authorized Audi Service Facility to see if you may use snow chains.

Use **fine-mesh snow chains**. They must not add more than 0.53 in (13.5 mm) in height, including the chain lock.

You must remove the snow chains on roads without snow. Otherwise, you could impair driving ability and damage the tires.



#### WARNING

Using incorrect snow chains or installing snow chains incorrectly can result in loss of vehicle

control, which increases the risk of an accident.

### ! Note

- Snow chains can damage the rims/wheel covers\* if the chains come into direct contact with them. Remove the wheel covers\* first. Use coated snow chains.
- Do not install and use snow chains if there is a malfunction in the air suspension\*, because the vehicle height will be very low. If you drive with snow chains anyway, the wheel housings and other vehicle components can be severely damaged.

### i Tips

When using snow chains, it may be useful to switch the offroad mode on ⇒ *page 141*.

## Low-profile tires

Applies to: vehicles with low-profile tires

Compared to other tire/rim combinations, low-profile tires offer a wider tread surface and a larger rim diameter with shorter tire sidewalls. This results in an agile driving style. However, it may reduce the level of comfort and increase road noise when driving on roads in poor condition.

Low-profile tires can become damaged more quickly than standard tires when driving over large bumps, potholes, manhole covers, and curbs. Therefore, it is particularly important to maintain the correct tire pressure ⇒ *page 335*.

To reduce the risk of damage to the tires and rims, drive very carefully on poor roads.

Check your wheels regularly every 2,000 mi (3,000 km) for damage. For example, check for bulges/cracks on the tires or deformations/cracks on the rims.

After a heavy impact or damage, have the tires and rims inspected or replaced immediately by an authorized Audi dealer or authorized Audi Service Facility.

Low-profile tires can wear out faster than standard tires.

## Uniform tire quality grading

- Tread wear
- Traction AA A B C
- Temperature A B C

Quality grades can be found where applicable on the tire side wall between tread shoulder and maximum section width ⇒ *page 326, fig. 266*.

**For example:** Tread wear **200**, Traction **AA**, Temperature **A**.

All passenger car tires must conform to Federal Safety Requirements in addition to these grades.

### Tread wear

The *tread wear* grade is a comparative rating based on the wear rate of the tire when tested under controlled conditions on a specified government test course.

For example, a tire graded 150 would wear one and one half (1 1/2) times as well on the government course as a tire graded 100.

The relative performance of tires depends upon the actual conditions of their use, however, and may depart significantly from the norm due to variations in driving habits, service practices and differences in road characteristics and climate.

### Traction

The *traction* grades, from highest to lowest, are AA, A, B and C. Those grades represent the tire's ability to stop on wet pavement as measured under controlled conditions on specified government test surfaces of asphalt and concrete. A tire marked C may have poor traction performance ⇒ ⚠.

### Temperature

The *temperature* grades are A (the highest), B, and C, representing the tire's resistance to the generation of heat and its ability to dissipate heat when tested under controlled conditions on a specified indoor laboratory test wheel.

Sustained high temperature can cause the material of the tire to degenerate and reduce tire life, and excessive temperature can lead to sudden tire failure ⇒ ⚠.

The grade C corresponds to a level of performance which all passenger car tires must meet under the Federal Motor Vehicle Safety Standard No. 109. Grades B and A represent higher levels of performance on the laboratory test wheel than the minimum required by law.

### **WARNING**

The traction grade assigned to this tire is based on straight-ahead braking traction tests, and does not include acceleration, cornering, hydroplaning or peak traction characteristics.

### **WARNING**

The temperature grade for this tire is established for a tire that is properly inflated and not overloaded. Excessive speed, underinflation, or excessive loading, either separately or in combination, can cause heat buildup and possible tire failure.

### **WARNING**

Temperature grades apply to tires that are properly inflated and not over or underinflated.

## Tire pressure monitoring system

### **General notes**

Each tire, including the spare (if provided), should be checked monthly when cold and inflated to the inflation pressure recommended by the vehicle manufacturer on the vehicle placard or tire inflation pressure label. (If your vehicle has tires of a different size than the size indicated on the vehicle placard or tire inflation pressure label, you should determine the proper tire inflation pressure for those tires).

As an added safety feature, your vehicle has been equipped with a tire pressure monitoring system (TPMS) that illuminates a low tire pressure telltale when one or more of your tires is significantly under-inflated. Accordingly, when the low tire pressure telltale illuminates, you should stop and

check your tires as soon as possible, and inflate them to the proper pressure. Driving on a significantly under-inflated tire causes the tire to overheat and can lead to tire failure. Under-inflation also reduces fuel efficiency and tire tread life, and may affect the vehicle's handling and stopping ability.

Please note that the TPMS is not a substitute for proper tire maintenance, and it is the driver's responsibility to maintain correct tire pressure, even if under-inflation has not reached the level to trigger illumination of the TPMS low tire pressure telltale.

Your vehicle has also been equipped with a TPMS malfunction indicator to indicate when the system is not operating properly. The TPMS malfunction indicator is combined with the low tire pressure telltale. When the system detects a malfunction, the telltale will flash for approximately one minute and then remain continuously illuminated. This sequence will continue upon subsequent vehicle start-ups as long as the malfunction exists.

When the malfunction indicator is illuminated, the system may not be able to detect or signal low tire pressure as intended. TPMS malfunctions may occur for a variety of reasons, including the installation of replacement or alternate tires or wheels on the vehicle that prevent the TPMS from functioning properly. Always check the TPMS malfunction telltale after replacing one or more tires or wheels on your vehicle to ensure that the replacement or alternate tires and wheels allow the TPMS to continue to function properly.

### **If the tire pressure monitoring indicator appears**

Applies to: vehicles with Tire Pressure Monitoring System indicator

*The tire pressure indicator in the instrument cluster informs you if the tire pressure is too low or if there is a system malfunction.*

Using the ABS sensors, the tire pressure monitoring system compares the tire tread circumference and vibration characteristics of the



individual tires. If the pressure changes in one or more tires, this is indicated in the instrument cluster display with an indicator light  and a message. If only one tire is affected, the location of that tire will be indicated.

The tire pressures must be stored in the Infotainment system again each time the pressures change (switching between partial and full load pressure) or after changing or replacing a tire on your vehicle ⇒ *page 343*. The tire pressure monitoring system only monitors the tire pressure you have stored. Refer to the tire pressure label for the recommended tire pressure for your vehicle ⇒ *page 335, fig. 269*.

Tire tread circumference and vibration characteristics can change and cause a tire pressure warning if:

- the tire pressure in one or more tires is too low
- the tires have structural damage
- the tire was replaced or the tire pressure was changed and it was not stored ⇒ *page 343*
- tires that are only partially used are replaced with new tires

### Indicator lights

 – loss of pressure in at least one tire ⇒ . Check the tires and replace or repair if necessary. Check/correct the pressures of all four tires and store the pressure again in the Infotainment system ⇒ *page 343*.

**TPMS** (Tire Pressure Monitoring System) **Tire pressure: malfunction! See owner's manual.** If **TPMS** appears after switching the ignition on or while driving and the  indicator light in the instrument cluster blinks for approximately one minute and then stays on, there is system malfunction. Try to store the correct tire pressures ⇒ *page 343*. In some cases, you must drive for several minutes after storing the pressures until the indicator light turns off. If the indicator light does turn off or turns on again after a short period of time, drive to an authorized Audi dealer or authorized Audi Service Facility immediately to have the malfunction corrected.

### WARNING

- If the tire pressure indicator appears in the display, reduce your speed immediately and avoid any hard steering or braking maneuvers. Stop as soon as possible and check the tires and their pressure.
- The driver is responsible for maintaining the correct tire pressure. You must check the tire pressure regularly.
- Under certain conditions (such as a sporty driving style, winter conditions or unpaved roads), the tire pressure monitoring system indicator may be delayed.

### Tips

- The tire pressure monitoring system can also stop working when there is an ESC malfunction.
- Using snow chains may result in a system malfunction.
- The tire pressure monitoring system in your Audi was calibrated with “Audi Original Tires” ⇒ *page 332*. Using these tires is recommended.

### Storing tire pressures

Applies to: vehicles with Tire Pressure Monitoring System indicator

*If the tire pressure changes or a tire is replaced, it must be confirmed in the Infotainment system.*

- ▶ Before storing the tire pressures, make sure the tire pressures of all four tires meet the specified values and are adapted to the load ⇒ *page 335*.
- ▶ Switch the ignition on.
- ▶ Select in the Infotainment system: **MENU** button > **Vehicle** > **Service & checks** > **Tire pressure monitoring** > **Store tire pressure** > **Yes, store now**.

### Tips

Do not store the tire pressures if snow chains are installed.

## Care and cleaning

### General information

Regular, proper care helps to maintain your vehicle's value. It can also be a requirement when submitting warranty claims for corrosion damage and paint defects on the body.

The required cleaning and care products can be obtained from an authorized Audi dealer or authorized Service Facility. Read and follow the instructions for use on the packaging.

#### **WARNING**

- Using cleaning and care products incorrectly can be dangerous to your health.
- Always store cleaning and care products out of reach of children to reduce the risk of poisoning.

#### **For the sake of the environment**

- Preferably purchase environmentally-friendly cleaning products.
- Do not dispose of leftover cleaning and care products with household trash.

### Car washes

The longer that deposits such as insects, bird droppings, tree sap or road salt remain on the vehicle, the more the surface can be damaged. High temperatures such as those caused by sunlight increase the damaging effect.

Before washing, rinse off heavy deposits with plenty of water.

Stubborn deposits such as bird droppings or tree sap are best removed with plenty of water and a microfiber cloth.

Also, wash the underside of your vehicle once road salt stops being used for the season.

#### **Pressure washers**

When washing your vehicle with a pressure washer, always follow the operating instructions provided with the pressure washer. This is especially important in regard to the pressure and spraying distance. Do not aim the spray directly at the

seals on the side windows, doors, lids or the sunroof\* or at tires, rubber hoses, insulating material, sensors\* or camera lenses\*. Keep a distance of at least 16 in (40 cm).

Do not remove snow and ice with a pressure washer.

Never use cone nozzles or high pressure nozzles.

The water temperature must not be above 140 °F (60 °C).

#### **Automatic car washes**

Spray off the vehicle before washing.

Make sure that the windows and roof\* are closed and the windshield wipers are off. Follow instructions from the car wash operator, especially if there are accessories attached to your vehicle.

If possible, use car washes that do not have brushes.

#### **Washing by hand**

Clean the vehicle starting from the top and working down using a soft sponge or cleaning brush. Use solvent-free cleaning products.

#### **Washing vehicles with matte finish paint by hand**

To avoid damaging the paint when washing, first remove dust and large particles from your vehicle. Insects, grease spots and fingerprints are best removed with a special cleaner for matte finish paint.

Apply the product using a microfiber cloth. To avoid damaging the paint surface, do not use too much pressure.

Rinse the vehicle thoroughly with water. Then clean using a neutral shampoo and a soft microfiber cloth.

Rinse the vehicle thoroughly again and let it air dry. Remove any water residue using a chamois.

#### **WARNING**

- Only wash the vehicle when the ignition is off and follow the instructions from the car

wash operator to reduce the risk of accidents.

- To reduce the risk of cuts, protect yourself from sharp metal components when washing the underbody or the inside of the wheel housings.
- After washing the vehicle, the braking effect may be delayed due to moisture on the brake rotors or ice in the winter. This increases the risk of an accident. The brakes must be dried first with a few careful brake applications.

### Note

- If you wash the vehicle in an automatic car wash, you must fold the exterior mirrors in to reduce the risk of damage to the mirrors. Power folding exterior mirrors\* must only be folded in and out using the power folding function.
- To reduce the risk of damage to the rims and tires, compare the width between the wheels on your vehicle with the distance between the guide rails in the car wash.
- To reduce the risk of damage, compare the height and width of your vehicle with the

height and width of the inside of the car wash.

- To reduce the risk of paint damage, do not wash the vehicle in direct sunlight.
- To reduce the risk of damage to the surface, do not use insect removing sponges, kitchen sponges or similar items.
- Matte finish painted vehicle components:
  - To reduce the risk of damage to the surface, do not use polishing agents or hard wax.
  - Never use protective wax. It can destroy the matte finish effect.
  - Do not place any stickers or magnetic signs on vehicle parts painted with matte finish paint. The paint could be damaged when the stickers or magnets are removed.

### For the sake of the environment

Only wash the vehicle in facilities specially designed for that purpose. This will reduce the risk of dirty water contaminated with oil from entering the sewer system.

## Cleaning and care information

When cleaning and caring for individual vehicle components, refer to the following tables. The information contained there is simply recommendations. For questions or for components

that are not listed, consult an authorized Audi dealer or authorized Audi Service Facility. Also follow the information found in ⇨ .

### Exterior cleaning

Component	Situation	Solution
Windshield wiper blades	Deposits	soft cloth with glass cleaner, ⇨ page 52
Headlights/ Tail lights	Deposits	Soft sponge with a mild soap solution <sup>a)</sup>
Sensors/ camera lenses	Deposits	Sensors: soft cloth with a solvent-free cleaning solution Camera lenses: soft cloth with an alcohol-free cleaning solution
	Snow/ice	Hand brush/solvent-free de-icing spray
Wheels	Road salt	Water
	Brake dust	Acid-free special cleaning solution

## Care and cleaning

Component	Situation	Solution
<b>Exhaust tail pipes</b>	Road salt	Water, cleaning solution suitable for stainless steel, if necessary
<b>Decorative parts/trim</b>	Deposits	Mild soap solution <sup>a)</sup> , a cleaning solution suitable for stainless steel, if necessary
<b>Paint</b>	Paint damage	Refer to the paint number on the vehicle data label, repair with touch up paint ⇒ <i>page 369</i>
	Spilled fuel	Rinse with water immediately
	Surface rust	Rust remover, then protect with hard wax; for questions, consult an authorized Audi dealer or authorized Audi Service Facility.
	Corrosion	Have it removed by an authorized Audi dealer or authorized Audi Service Facility.
	Water no longer beads on the surface of clean paint	Protect with hard wax (at least twice per year)
	No shine even though paint has been protected/paint looks poor	Treat with suitable polish; then apply paint protectant if the polish that was used does not contain any protectant
	Deposits such as insects, bird droppings, tree sap and road salt	Dampen with water immediately and remove with a micro-fiber cloth
	Grease-based contaminants such as cosmetics or sunblock	Remove immediately with a mild soap solution <sup>a)</sup> and a soft cloth
<b>Carbon parts</b>	Deposits	clean the same way as painted parts ⇒ <i>page 344</i>
<b>Decorative decals</b>	Deposits	Soft sponge with a mild soap solution <sup>a)</sup>

<sup>a)</sup> Mild soap solution: maximum two tablespoons of neutral soap in 1 quart (1 liter) of water

## Interior cleaning

Component	Situation	Solution
<b>Window glass</b>	Deposits	Glass cleaner, then wipe dry
<b>Decorative parts/trim</b>	Deposits	Mild soap solution <sup>a)</sup>
<b>Plastic parts</b>	Deposits	Damp cloth
	Heavier deposits	Mild soap solution <sup>a)</sup> , detergent-free plastic cleaning solution, if necessary
<b>Displays/instrument cluster</b>	Deposits	Soft cloth with LCD cleaner; dust in the lower area of the instrument cluster can be removed using a soft brush.
<b>Controls</b>	Deposits	Soft brush, then a soft cloth with a mild soap solution <sup>a)</sup>
<b>Safety belts</b>	Deposits	Mild soap solution <sup>a)</sup> , allow to dry before letting them retract

Component	Situation	Solution
<b>Textiles, artificial leather, Alcantara</b>	Deposits adhering to the surface	Vacuum cleaner
	Water-based deposits such as coffee, tea, blood, etc.	Absorbent cloth and mild soap solution <sup>a)</sup>
	Oil-based deposits such as oil, make-up, etc.	Apply a mild soap solution <sup>a)</sup> , blot away the dissolved oil or dye, treat afterward with water, if necessary
	Special deposits such as ink, nail polish, latex paint, shoe polish, etc.	Special stain remover, blot with absorbent material, treat afterward with mild soap solution, if necessary <sup>a)</sup>
<b>Natural leather</b>	Fresh stains	Cotton cloth with a mild soap solution <sup>a)</sup>
	Water-based deposits such as coffee, tea, blood, etc.	Fresh stains: absorbent cloth Dried stains: stain remover suitable for leather
	Oil-based deposits such as oil, make-up, etc.	Fresh stains: absorbent cloth and stain remover suitable for leather Dried stains: oil cleaning spray
	Special deposits such as ink, nail polish, latex paint, shoe polish, etc.	Spot remover suitable for leather
	Care	Regularly apply conditioning cream that protects from light and penetrates into the material. Use special colored conditioning cream, if necessary.
<b>Carbon parts</b>	Deposits	clean the same way as plastic parts

<sup>a)</sup> Mild soap solution: maximum two tablespoons of neutral soap in 1 quart (1 liter) of water

### **WARNING**

The windshield may not be treated with water-repelling windshield coating agents. Unfavorable conditions such as wetness, darkness, or low sun can result in increased glare. Wiper blade chatter is also possible.

### **Note**

- **Headlights/tail lights**
  - Never clean headlights or tail lights with a dry cloth or sponge.
  - Do not use any cleaning product that contains alcohol, because they could cause cracks to form.
- **Wheels**

- Never use any paint polish or other abrasive materials.
- Damage to the protective layer on the rims such as stone chips or scratches must be repaired immediately.
- **Camera lenses**
  - Never use warm or hot water to remove snow or ice from the camera lens. This could cause the lens to crack.
  - Never use abrasive cleaning materials or alcohol to clean the camera lens. This could cause scratches and cracks.
- **Door windows**
  - Remove snow and ice on windows and exterior mirrors with a plastic scraper. To

avoid scratches, move the scraper only in one direction and not back and forth.

- Never remove snow or ice from door windows and mirrors using warm or hot water because this could cause cracks to form.
- To avoid damage to the rear window defogger, do not apply any stickers on the heating wires on the inside of the window.
- **Decorative parts/trim**
  - Never use chrome care or cleaning products.
- **Paint**
  - To reduce the risk of scratches, the vehicle must be free of dirt and dust before polishing or waxing.
  - To prevent paint damage, do not polish or wax the vehicle in direct sunlight.
  - To reduce the risk of paint damage, do not polish away rust spots.
  - Remove cosmetics and sunscreen immediately - these could damage the paint.
- **Displays/instrument cluster**
  - Make sure that the instrument cluster is switched off and has cooled off before cleaning it.
  - Displays, the instrument cluster and the trim surrounding it must not be cleaned with dry cleaning methods because they could become scratched.
  - Make sure no fluids enter the spaces between the instrument cluster and the trim, because that could cause damage.
- **Controls**
  - Make sure that no fluids enter the controls, because this could cause damage.
- **Safety belts**
  - Do not remove the safety belts to clean them.
  - Never clean safety belts or their components chemically or with corrosive fluids or solvents and never allow sharp objects to come into contact with the safety belts. This could cause damage to the belt webbing.
  - If there is damage to the webbing, the connections, the retractors or the buckles,

have them replaced by an authorized Audi dealer or authorized Audi Service Facility.

- **Textiles/artificial leather/Alcantara**
  - Never treat artificial leather/Alcantara with leather care products, solvents, floor polish, shoe polish, spot remove or similar products.
  - Have a specialist remove stubborn stains to prevent damage.
  - Never use steam cleaners, brushes, hard sponges, etc. when cleaning.
  - Do not turn on the seat heating\* to dry the seat.
  - Objects with sharp edges, such as zippers or rivets on clothing or belts, can cause damage to the surface.
  - Open hook and loop fasteners, for example on clothing, can damage seat covers. Make sure hook and loop fasteners are closed.
- **Natural leather**
  - Never treat leather with solvents, floor polish, shoe polish, spot remover or similar products.
  - Objects with sharp edges, such as zippers or rivets on clothing or belts, can cause damage to the surface.
  - Never use steam cleaners, brushes, hard sponges, etc. when cleaning.
  - Do not turn on the seat heating\* to dry the seat.
  - To help prevent the leather from fading, do not leave the vehicle in direct sunlight for long periods of time. If leaving the vehicle parked for long periods of time, you should cover the leather to protect it from direct sunlight.

### Tips

- Insects are easier to remove from paint that has been freshly waxed.
- Regular waxing can prevent rust spots from forming.

## Placing your vehicle out of service

If you would like to take your vehicle out of service for a longer time, contact an authorized Audi dealer or authorized Audi Service Facility. They will advise you of important measures, such as corrosion protection, service and storage procedures. Also follow the information about the vehicle battery ⇒ *page 321*.

## Emergency assistance

### General information

- ▶ Park the vehicle as far as possible from moving traffic in the event of a breakdown. In the event of a flat tire, park the vehicle on a level surface. If you are on a steep hill, be especially careful.
- ▶ Set the parking brake.
- ▶ Switch the emergency flashers on.
- ▶ Have the passengers exit the vehicle. They should move to a safe place, for example behind a guard rail.

#### WARNING

Follow the steps given above. This is for your protection and the for the safety of other drivers.

### Equipment

#### Vehicle tool kit/tire mobility kit/vehicle jack

Applies to: vehicles with the vehicle tool kit, tire mobility kit and vehicle jack

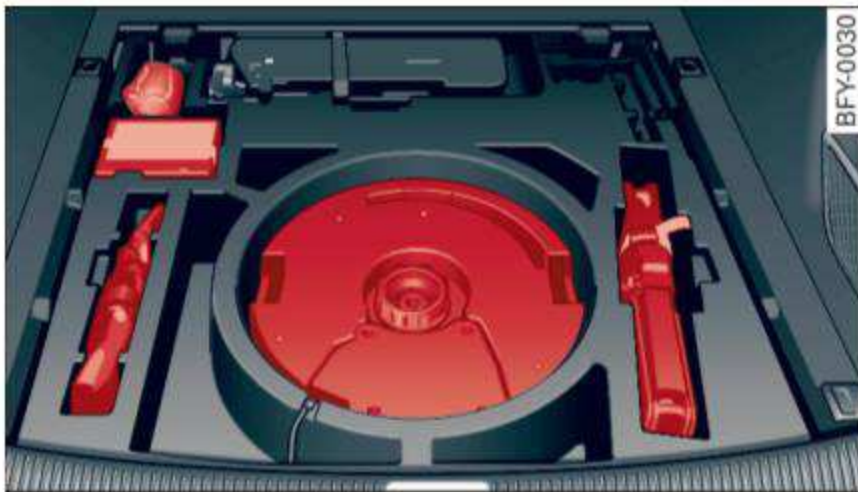

Fig. 270 Luggage compartment: vehicle tool kit, vehicle jack, tire mobility kit and compressor

The vehicle tool kit, vehicle jack, tire mobility kit and compressor are stored in the luggage compartment under the cargo floor cover. Lift the cargo floor using the handle.

#### WARNING

Improper use of the vehicle jack can cause serious personal injuries.

- Never use the screw driver hex head to tighten wheel bolts, since the bolts cannot attain the necessary tightening torque if you

use the hex head, potentially causing an accident.

- The factory-supplied jack is intended only for your vehicle model. Under no circumstances should it be used to lift heavy vehicles or other loads; you risk injuring yourself.
- Never start the engine when the vehicle is raised, which could cause an accident.
- Support the vehicle securely with appropriate stands if work is to be performed underneath the vehicle; otherwise, there is a potential risk for injury.
- Never use the jack supplied with your Audi on another vehicle, particularly on a heavier one. The jack is only suitable for use on the vehicle it came with.

#### Tips

The vehicle jack in your vehicle is maintenance-free.

### Tire mobility kit

#### Preparation

Applies to: vehicles with tire mobility kit

- ▶ Read and follow the important safety precautions ⇒ *page 350*.
- ▶ Set the parking brake.
- ▶ Select the "P" selector lever position.
- ▶ Check if a repair with the tire mobility kit is possible ⇒ *page 350*.

#### Using the tire mobility kit

Applies to: vehicles with tire mobility kit



Fig. 271 Tire: tire damage that cannot be repaired

The tire repair is only meant for temporary use. Change the spare tire as soon as possible ⇨ ⚠.

If the tire is pierced by an object such as a nail, do not remove the object from the tire.

The tire mobility kit can be used at temperatures as low as -4 °F (-20 °C).

### The tire mobility kit may not be used:

- if the tire has cuts or punctures that are larger than 0.16 in (4 mm) ① ⇨ *fig. 271*
- if the rim is damaged ②
- if you drove with very low tire pressure or without air in the tire ③

See an authorized Audi dealer or authorized Audi Service Facility for assistance in these situations.

### ⚠ WARNING

- Please note that the tire mobility kit cannot be used in all situations, and that it may only be used temporarily.
- The tire sealant must not come in contact with skin, eyes, or clothes.
- If tire sealant gets in your eyes or on your skin, thoroughly rinse the affected area immediately with clean water.
- Do not inhale the fumes.
- If you swallow any of the tire sealant, thoroughly rinse your mouth immediately and drink a lot of water. Do not induce vomiting. Seek medical attention immediately.
- Change your clothes immediately if they get tire sealant on them.
- If an allergic reaction occurs, seek immediate medical attention.
- Keep the tire sealant away from children.

### i Tips

- If sealant leaks, allow it to dry in place. You can then peel it off like a sticker.
- Note the expiration date on the sealant bottle. Replace the tire sealant at an authorized Audi dealer or authorized Audi Service Facility.
- Radio reception can be interrupted when operating the compressor.
- Obey all laws.

## Repairing tires

Applies to: vehicles with tire mobility kit

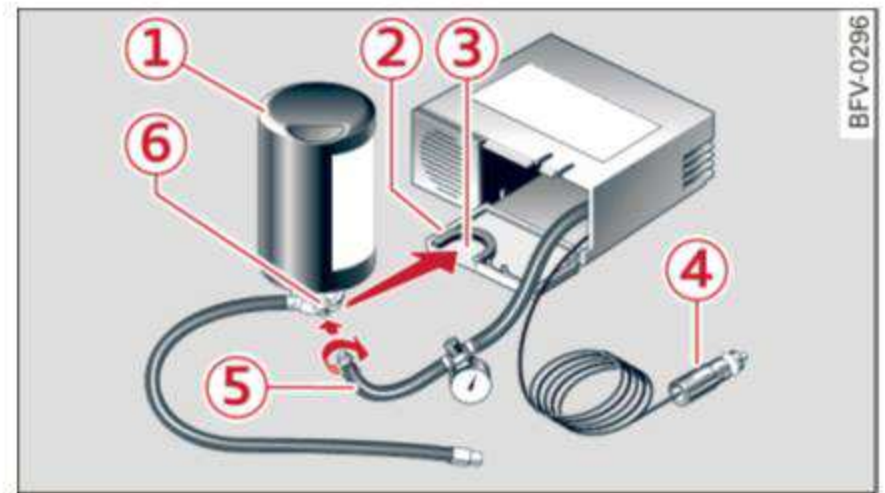

Fig. 272 Components of the tire mobility kit

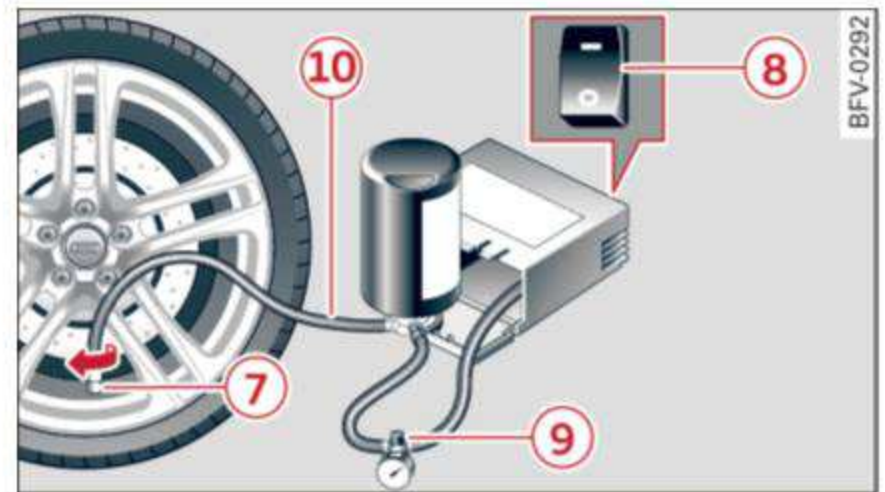

Fig. 273 Tire mobility kit connection

Requirement: the tire mobility kit must be laid out and ready for use ⇨ *page 350*.

### Installing the tire mobility kit

- ▶ Open the cover ② on the compressor ⇨ *fig. 272*.
- ▶ Remove the connector ④ and pressure hose ⑤ with pressure gauge from the housing.
- ▶ Install the compressor pressure hose ⑤ onto the flange ⑥ on the tire sealant bottle ①.
- ▶ Insert the sealant bottle with the flange at the bottom into the opening ③ on the compressor cover.
- ▶ Remove the valve cap from the faulty tire.
- ▶ Install the filler hose ⑩ on the valve ⑦ ⇨ *fig. 273*.
- ▶ Connect the plug ④ ⇨ *fig. 272* to an outlet in the vehicle.
- ▶ Switch the ignition on.

### Inflating a tire

- ▶ Move the switch ⑧ ⇨ *fig. 273* on the compressor into position **I**.

## Emergency assistance

- ▶ Inflate the tire to between 29 psi (200 kPa) and 36 psi (250 kPa) and read the pressure on the gauge.
- ▶ If this tire pressure is not reached, remove the filler hose. Drive slowly approximately 33 feet (10 m) forward or in reverse so that the sealant can be distributed in the tire. Pump up the tire again ⇒ ⚠.

### ⚠ WARNING

- Read and follow the manufacturer's safety precautions on the compressor and in the instructions on the bottle of sealant.
- If a tire pressure of 29 psi (200 kPa) cannot be reached after inflating for 6 minutes, then the tire is too severely damaged. Do not continue driving.
- If the tire cannot be repaired with the tire sealant, see an authorized Audi dealer or authorized Audi Service Facility for assistance.

### i Tips

Do not operate the compressor for more than six minutes continuously, or it can overheat. Once the compressor has cooled, you can continue to use it.

## Completing

Applies to: vehicles with tire mobility kit

- ▶ Adhere the sticker that says "max. 50 mph (max. 80 km/h)" that is provided with the tire mobility kit within the driver's field of vision.
- ▶ Stop the vehicle after driving for about 10 minutes and check the tire pressure.
- ▶ If the tire pressure is lower than 19 psi (130 kPa), then the tire is too severely damaged. Do not continue driving.

### ⚠ WARNING

Pay attention to the following after repairing the tire:

- Do not drive faster than 50 mph (80 km/h).
- Avoid hard acceleration, braking sharply, and fast cornering.
- The vehicle may become more difficult to control.

– If the tire is too severely damaged, see an authorized Audi dealer or authorized Audi Service Facility for assistance.

### 🌱 For the sake of the environment

You can give the used tire sealant bottle to an authorized Audi dealer or authorized Audi Service Facility for disposal.

### i Tips

Remember to obtain a new bottle of sealant from an authorized Audi dealer or authorized Audi Service Facility after repairing a tire.

## Replacing a wheel

### Preparation

*You must complete the preparation before changing a tire.*

- ▶ Read and follow the important safety precautions ⇒ *page 350*.
- ▶ Set the parking brake.
- ▶ Select the "P" selector lever position.
- ▶ When towing a trailer: disconnect the trailer from your vehicle.
- ▶ Switch on wheel change mode\* in the Infotainment system: **MENU** button > **Vehicle** > left control button > **Service & checks** > **Air suspension: wheel change**.
- ▶ Switch the ignition off.

The vehicle jack mode\* switches off automatically at speeds above 6 mph (10 km/h).

### ⚠ WARNING

When using the vehicle jack\* on a road with a steep hill or offroad, you must take extra precautions to prevent the vehicle from rolling. Use suitable objects to block the front and back of the wheel that is diagonal from the wheel with the flat tire.

### ⚠ WARNING

You or your passengers could be injured while changing a wheel if you do not follow these safety precautions:

- If you have a flat tire, move a safe distance off the road. Turn off the engine, turn the emergency flashers on and use other warning devices to alert other motorists.
- Make sure that passengers wait in a safe place away from the vehicle and well away from the road and traffic.
- To help prevent the vehicle from moving suddenly and possibly slipping off the jack\*, always fully set the parking brake and block the front and back of the wheel diagonally opposite the wheel being changed. When one front wheel is lifted off the ground, placing the Automatic Transmission in P (Park) will *not* prevent the vehicle from moving.
- Before you change a wheel, be sure the ground is level and firm. If necessary, use a sturdy board under the jack\*.
- Always store the vehicle tool kit, the jack\* and the replaced tire in the luggage compartment ⇒ *page 257*.

### **i** Tips

- Obey all laws.
- Before changing the wheel, you must activate the jacking mode\*, so that the automatic controls for the air suspension\* do not make it more difficult to lift the vehicle with the jack\* ⇒ *page 354*.

### Removing the caps



Fig. 274 Wheel: wheel bolts with caps

- ▶ Slide the plastic clip (from the vehicle tool kit) onto the cap until it engages ⇒ *fig. 274*.
- ▶ Remove the cap with the plastic clip.

### Loosening the wheel bolts



Fig. 275 Wheel: loosening the wheel bolt

- ▶ Slide the wheel wrench (from the vehicle tool kit) all the way onto the wheel bolt.
- ▶ Turn the wheel bolt approximately one turn to the left -arrow-. To reach the required torque, hold the end of the wheel wrench. If the wheel bolt will not loosen, press carefully on the wheel wrench with your foot. Hold onto the vehicle securely while during this and make sure your stance is stable.

### **!** WARNING

To reduce the risk of an accident, only loosen the wheel bolts gently (one turn) before raising the vehicle with the vehicle jack\*.

**Raising the vehicle**

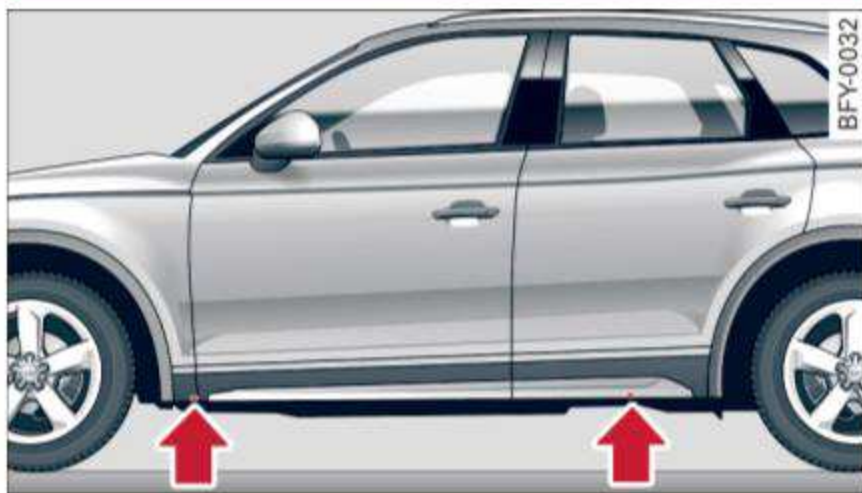

Fig. 276 Sill panels: markings

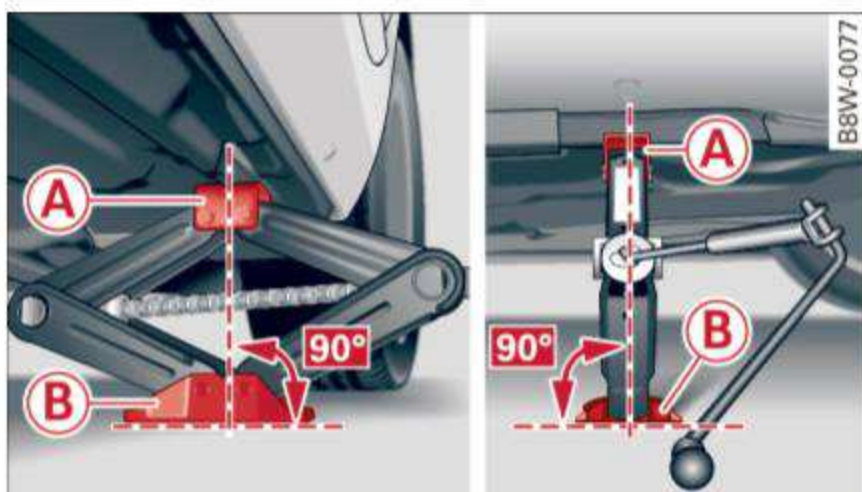

Fig. 277 Sill: positioning the vehicle jack

- ▶ Place the vehicle jack\* (vehicle tool kit) on a firm surface. Use a flat, stable support if necessary. On a slippery surface such as tile, you should use a non-slip pad (such as a rubber mat) ⇒ ⚠.
- ▶ Find the marking on the sill that is closest to the tire that will be changed ⇒ *fig. 276*. Behind the marking, there is a lifting point on the side sill for the vehicle jack\*.
- ▶ Turn the handwheel to raise the vehicle jack\* under the lifting point on the side sill until the bracket on the jack (A) completely covers the notch on your vehicle.
- ▶ Align the vehicle jack\* so the bracket (A) covers the notch and the base (B) is flat on the ground. The base (B) must be directly under the lifting point (A).
- ▶ Mount the crank on the vehicle jack\*: insert the crank into the opening on the handwheel. Turn the crank to the left or right to secure it.
- ▶ Continue raising the vehicle jack\* with the crank until the wheel lifts off the ground slightly.

**⚠ WARNING**

- Make sure the vehicle jack\* is stable. There is a risk of injury when the ground is slick or soft, because the vehicle jack\* could slide or sink.
- Only raise your vehicle with the vehicle jack\* provided by the factory. If you use a vehicle jack designed for another vehicle, your vehicle can slide and cause injury.
- Position the vehicle jack\* only at the designated mounting points on the side sill and align the jack. Otherwise, the vehicle jack\* could slip and cause an injury if it does not have sufficient hold on the vehicle.
- Vehicles with air suspension\*: changes in temperature or load can affect the height of the stopped vehicle.
- To reduce the risk of an accident, never start the engine when the vehicle is raised.
- To reduce the risk of injury, support the vehicle securely with suitable stands if work is to be performed underneath the vehicle.
- To help prevent injury to yourself and your passengers:
  - Do not raise the vehicle until you are sure the jack\* is securely engaged.
  - Passengers must not remain in the vehicle when it is jacked up.
  - Make sure that passengers wait in a safe place away from the vehicle and well away from the road and traffic.
  - Make sure jack position is correct, adjust as necessary and then continue to raise the jack\*.
  - If work has to be done under the vehicle, ensure that it is safely supported on suitable stands – risk of injury!
  - Never start the engine when the vehicle is on the jack\* – risk of accident!

**! Note**

Do not lift the vehicle by the sill. Position the vehicle jack\* only at the designated mounting points on the side sill. Otherwise, your vehicle will be damaged.

**i Tips**

The vehicle jack mode\* switches off automatically at speeds above 6 mph (10 km/h).

**Removing and installing a wheel**

Fig. 278 Wheel: internal hex socket to turn the wheel bolts



Fig. 279 Wheel: alignment pin in the top hole

**Removing a wheel**

- ▶ Remove the top wheel bolt completely using the hex socket in the screwdriver handle (in the vehicle tool kit) ⇒ *fig. 278* and place it on a clean surface.
- ▶ Then install the alignment pin (from the vehicle tool kit) by hand into the empty wheel bolt hole ⇒ *fig. 279*.
- ▶ Remove the rest of the wheel bolts.
- ▶ Remove the wheel ⇒ . The alignment pin remains in the hole while doing this.

**Install a wheel**

Read the directions on ⇒ *page 355* when installing unidirectional tires.

- ▶ Slide the wheel on over the alignment pin ⇒ .
- ▶ Install the wheel bolts and tighten gently using the hex socket.

- ▶ Remove the alignment pin and also tighten the remaining wheel bolt.
- ▶ Carefully lower the vehicle using the vehicle jack\*.
- ▶ Tighten the wheel bolts in a diagonal pattern using the wheel wrench.

The wheel bolts must be clean and loosen/tighten easily. Check the contact surfaces for the wheel and hub. Contaminants on these surfaces must be removed before installing the wheel.

**! WARNING**

Never use the hex socket in the screwdriver handle or the hex socket wrench with the ratchet to loosen or tighten the wheel bolts. This increases the risk of an accident, because you will not reach the tightening specification required.

**! Note**

When removing or installing the wheel, the rim could hit the brake rotor and damage the rotor. Work carefully and have a second person help you.

**i Tips**

- When mounting tires with **unidirectional tread design** make sure the tread pattern is pointed the right way ⇒ *page 355*.
- The wheel bolts should be clean and easy to turn. Check for dirt and corrosion on the mating surfaces of both the wheel and the hub. Remove all dirt from these surfaces before remounting the wheel.

**Unidirectional tires**

A unidirectional tire profile is identified by arrows that point in the running direction on the tire sidewall. You must always adhere to the specified running direction. This is necessary ensure the tire's optimum performance in regard to adhesion, running noise, friction and hydroplaning.

To benefit fully from the advantages of the unidirectional tire design, you should replace faulty tires as soon as possible and restore the correct running direction on all of the tires.

### Finishing

- ▶ Reinstall the caps on the wheel bolts if necessary.
- ▶ Store the vehicle tool kit in its designated place.
- ▶ If the removed wheel does not fit in the spare wheel well, store it securely in the luggage compartment ⇒ *page 257*.
- ▶ Check the tire pressure on the installed wheel as soon as possible.
- ▶ Correct the tire pressure and store it in the Infotainment system ⇒ *page 343*.
- ▶ The wheel bolt tightening specification must be 100 ft lbs (140 Nm). Check it as soon as possible with a torque wrench. Drive carefully until then.
- ▶ Have the faulty wheel replaced as quickly as possible.

### Tips

- If you notice that the wheel bolts are corroded and difficult to turn while changing a tire, they should be replaced before you check the tightening torque.
- Drive at reduced speed until you have the tightening torques checked.

### Notes on wheel changing

Please read the information ⇒ *page 332* if you are going to use a replacement tire which is different from the tires on your vehicle.

After you change a tire:

- **Check the tire pressure on the replacement tire immediately after installation.**
- **Have the wheel bolt tightening torque checked with a torque wrench as soon as possible by your authorized Audi dealer or qualified workshop.**
- **With steel and alloy wheel rims, the wheel bolts are correctly tightened at a torque of 100 ft lbs (140 Nm).**
- **If you notice that the wheel bolts are corroded and difficult to turn while changing a tire, they should be replaced before you check the tightening torque.**

- **Replace the flat tire with a new one and have it installed on your vehicle as soon as possible. Remount the wheel cover.**

**Until then, drive with extra care and at reduced speeds.**

### WARNING

- If you are going to equip your vehicle with tires or rims which differ from those which were factory installed, then be sure to read the information ⇒ *page 332*.
- Always make sure the damaged wheel or even a flat tire and the jack\* and tool kit are properly secured in the luggage compartment and are not loose in the passenger compartment.
- In an accident or sudden maneuver they could fly forward, injuring anyone in the vehicle.
- Always store damaged wheel, jack\* and tools securely in the luggage compartment. Otherwise, in an accident or sudden maneuver they could fly forward, causing injury to passengers in the vehicle.

## Collapsible spare tire

Applies to: vehicles with collapsible spare tire

The collapsible spare tire is intended for short-term use only. Have the damaged tire checked and replaced, if necessary, by an authorized Audi dealer or authorized Audi Service Facility as soon as possible.

There are some restrictions on the use of the collapsible spare tire. The collapsible spare tire has been designed specifically for your type of vehicle. Do not replace it with the collapsible spare tire from another type of vehicle.

The collapsible spare tire is located in the luggage compartment under the cargo floor cover.

Requirement: the vehicle tool kit ⇒ *page 350* and the compressor must be laid out.

### Removing

- ▶ Fold the cargo floor cover back ⇒ *page 350*, *fig. 270*.

- ▶ Turn the handwheel counter-clockwise and remove it.
- ▶ Remove the collapsible spare tire.

You must inflate the collapsible spare tire beforehand in order to use it.

### Inflating

- ▶ Remove the valve cap from the collapsible spare tire.
- ▶ Tighten the compressor hose on the collapsible spare tire valve.
- ▶ Connect the compressor hose to a vehicle socket and switch it on.
- ▶ Let the compressor run until the specified value on the tire pressure sticker is reached  
⇒ *page 335, fig. 269* ⇒ .
- ▶ Screw the valve cap back onto the valve.

### Returning to storage

- ▶ Remove the valve cap to drain the air.
- ▶ Wait several hours before placing the collapsible spare tire in the spare wheel well. Only then will it fold down completely so that you can store it securely.
- ▶ Then screw the valve cap back onto the valve.
- ▶ Secure the collapsible spare tire with the handwheel.
- ▶ Fold the cargo floor cover back into place.

### Snow chains

Using snow chains on the collapsible spare tire is not permitted for technical reasons.

If you have to drive with snow chains and a rear tire fails, mount the collapsible spare tire in place of a front tire. Install the snow chains on the front tire that you removed, and install that in place of the rear tire that failed.

#### **WARNING**

- Only use the collapsible spare tire in emergencies and drive very carefully, especially if it is more than six years old.
- The compressor and the hose can become very hot during operation which increases the risk of burn injuries.

- After installing a collapsible spare tire, the tire pressure must be checked as quickly as possible to reduce the risk of an accident.
- Do not drive faster than 50 mph (80 km/h) with the collapsible spare tire. Driving faster than that increases the risk of an accident.
- Avoid full-throttle acceleration, heavy braking, and fast cornering with the collapsible spare tire, because this increases the risk of an accident.
- Never drive using more than one collapsible spare tire, because this increases the risk of an accident.
- Normal tires or winter tires must not be mounted on the collapsible spare tire rim.

#### **Note**

The compressor must be switched off after 12 minutes at the most to reduce the risk of overheating. Let the compressor cool down for several minutes before using it again.

## Fuses and bulbs

### Fuses

#### Replacing fuses

A fuse that has blown will have metal strips that have burned through.

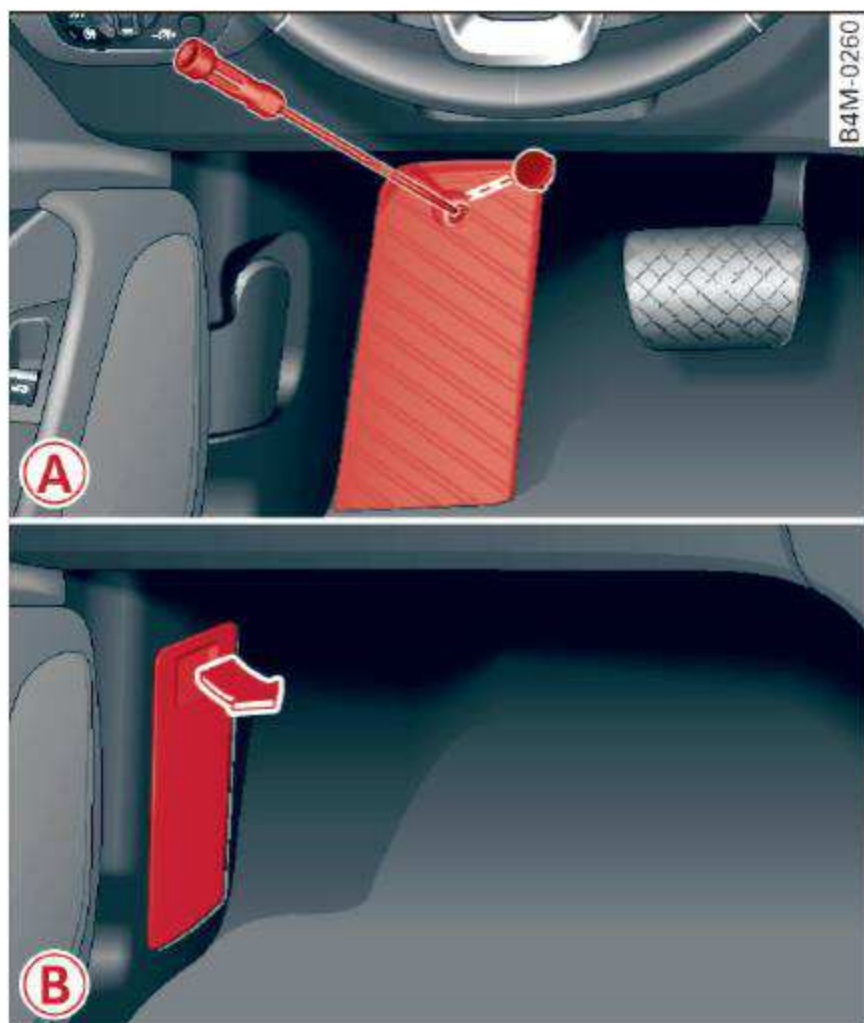

**Fig. 280** (A) Driver footwell (left-hand drive vehicle): footrest, (B) Front passenger footwell (right-hand drive vehicle): cover

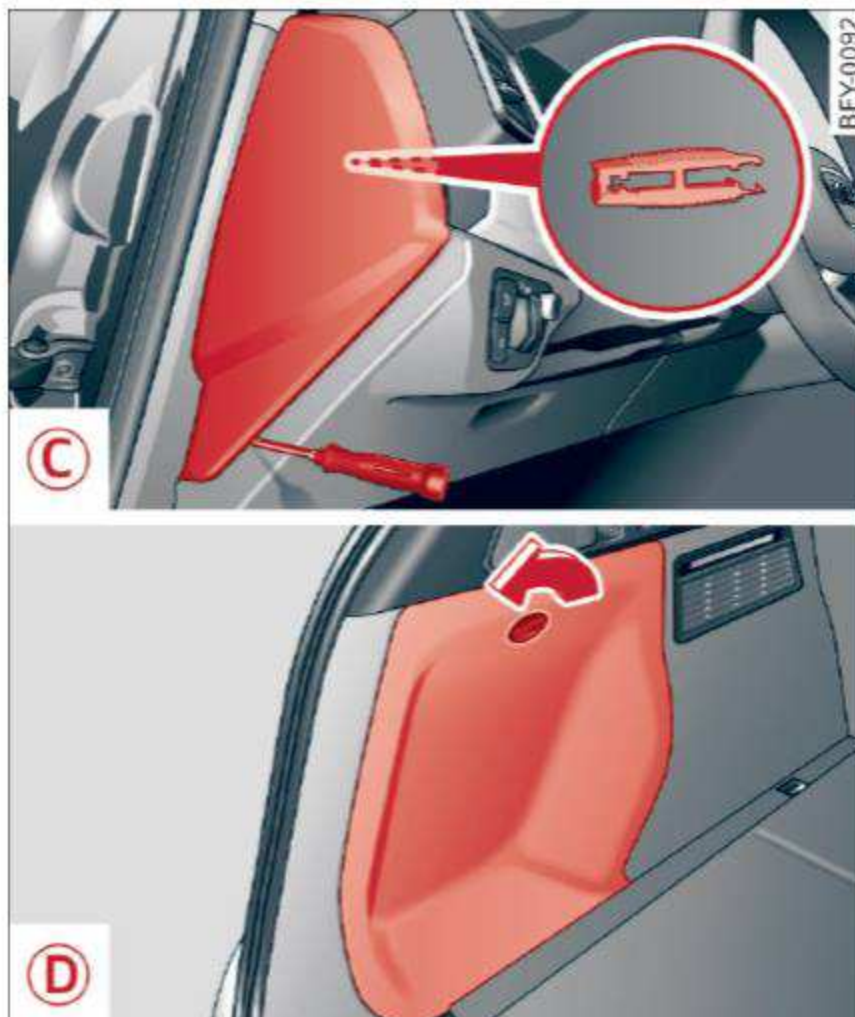

**Fig. 281** (C) Driver's side of the cockpit (left-hand drive vehicle/right-hand drive vehicle): cover, (D) Left side of luggage compartment: cover

The fuses are located in the footwell under the foot rest (left-hand drive vehicle) (A) ⇒ *fig. 280* or behind the cover (right-hand drive vehicle) (B). Additional fuses are located on the front side of the cockpit (driver's side) (C) ⇒ *fig. 281* and under the left cover in the luggage compartment (D).

- ▶ Switch the ignition and all electrical equipment off.
- ▶ Check the following table to see which fuse belongs to the equipment.
- ▶ Remove the screwdriver and the reversible Torx bit from the vehicle tool kit ⇒ *page 350*.
- ▶ Remove the footrest or the corresponding cover.
- ▶ Remove the colored plastic clip from the fuse panel, if necessary ⇒ *page 359, fig. 282*. You can dispose of the plastic clip.
- ▶ Remove the clip from the rear side of the cover (C).
- ▶ Remove the fuse using the clip.
- ▶ Replace the blown fuse only with an identical new one.
- ▶ Reattach the footrest or the cover.

Fuse color identification

Color	Current rating in amps
Black	1
Purple	3
Light brown	5
Brown	7.5
Red	10
Blue	15
Yellow	20
White or transparent	25
Green	30
Orange	40

**⚠ WARNING**

Do not repair fuses and never replace a blown fuse with one that has a higher amp rating. This can cause damage to the electrical system and increases the risk of fire.

**! Note**

If a new fuse burns out again shortly after you have installed it, have the electrical system checked as soon as possible by an authorized Audi dealer or authorized Audi Service Facility.

**i Tips**

- The following table does not list fuse locations that are not used.
- Some of the equipment listed in the following tables applies only to certain model versions or certain optional equipment.

Fuse assignment - driver's/front passenger's footwell

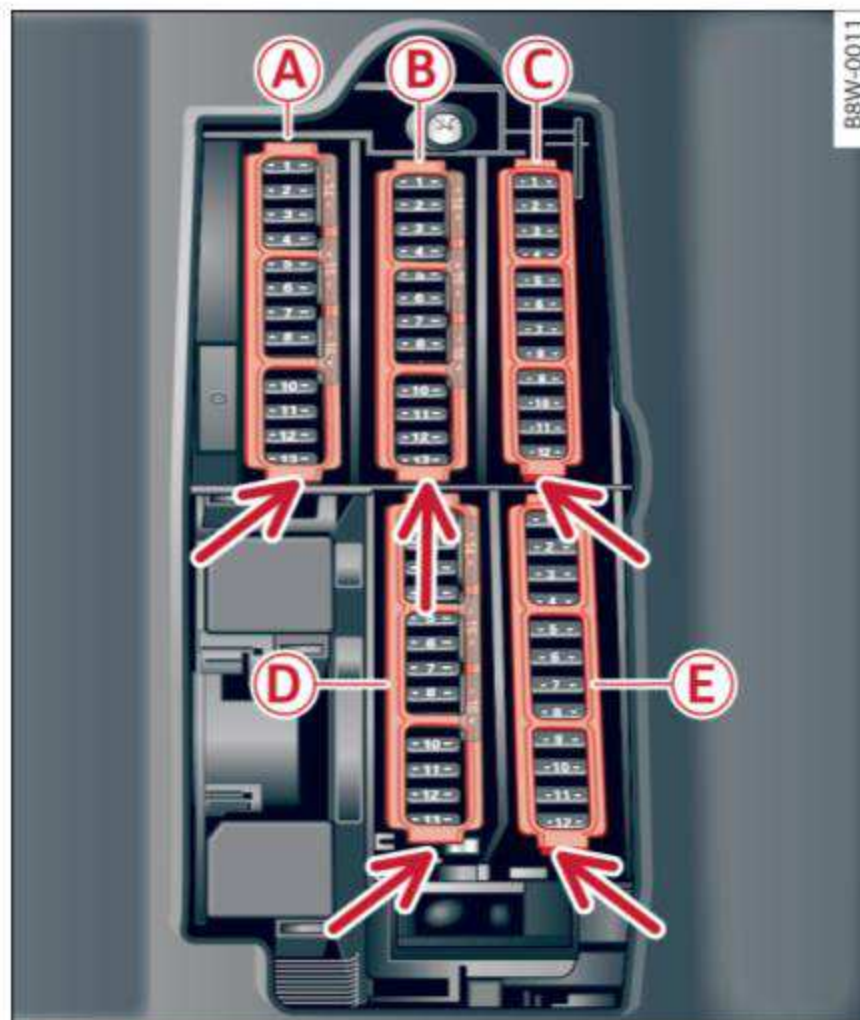

Fig. 282 Driver's footwell (left-hand drive vehicle): fuse panel with plastic clip

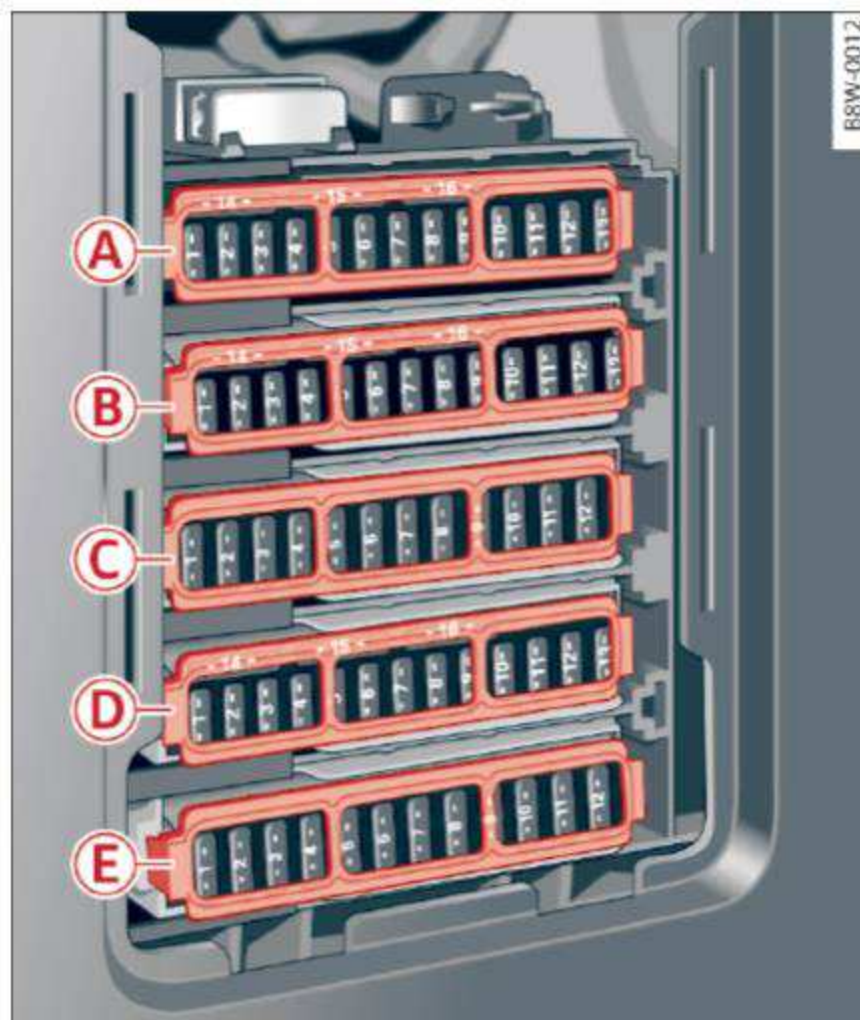

Fig. 283 Front passenger's footwell (right-hand drive vehicle): fuse panel with plastic clip

## Fuses and bulbs

Fuse panel <b>(A)</b> (brown)	
No.	Equipment
2	Mass airflow sensor, camshaft adjustment, charge air cooler pump
3	Exhaust doors, fuel injectors, radiator inlet
4	Vacuum pump, hot water pump, particulate sensor, biodiesel sensor
5	Brake light sensor
6	Engine valves, camshaft adjustment
7	Heated oxygen sensor, mass airflow sensor
8	Water pump, high pressure pump, high pressure regulator valve
9	Hot water pump
10	Oil pressure sensor, oil temperature sensor
11	Clutch pedal position sensor
12	Engine valves
13	Radiator fan
14	Fuel injectors
15	Ignition coils
16	Fuel pump

Fuse panel <b>(B)</b> (red)	
No.	Equipment
1	Anti-theft alarm system
2	Engine control module
3	Lumbar support
4	Automatic transmission selector mechanism
5	Horn
6	Electromechanical parking brake
7	Gateway control module
8	Interior headliner lights
10	Airbag control module
11	Electronic Stabilization Control (ESC)
12	Diagnostic connector, light/rain sensor
13	Climate control system
14	Right front door control module
15	A/C compressor

Fuse panel <b>(C)</b> (black)	
No.	Equipment
1	Front seat heating
2	Windshield wipers
3	Left headlight electronics
4	Panorama glass roof
5	Left front door control module
6	Sockets
7	Right rear door control module
8	All wheel drive
9	Right headlight electronics
10	Windshield washer system/headlight washer system
11	Left rear door control module

Fuse panel <b>(D)</b> (black)	
No.	Equipment
1	Seat ventilation, rearview mirror, climate control system, rear climate control system controls, windshield defogger
2	Gateway, climate control system
3	Sound actuator/exhaust sound tuning
4	Clutch pedal position sensor
5	Engine start
7	Rear USB charging port
8	HomeLink
9	Adaptive cruise control
11	Video camera
12	Matrix LED headlight/right LED headlight
13	Matrix LED headlight/left LED headlight
14	Rear window wiper

Fuse panel <b>(E)</b> (red)	
No.	Equipment
1	Ignition coils
5	Engine mount
6	Automatic transmission
7	Instrument panel
8	Climate control system (blower)
10	Dynamic steering
11	Engine start

**Fuse assignment - Driver's side of the cockpit**

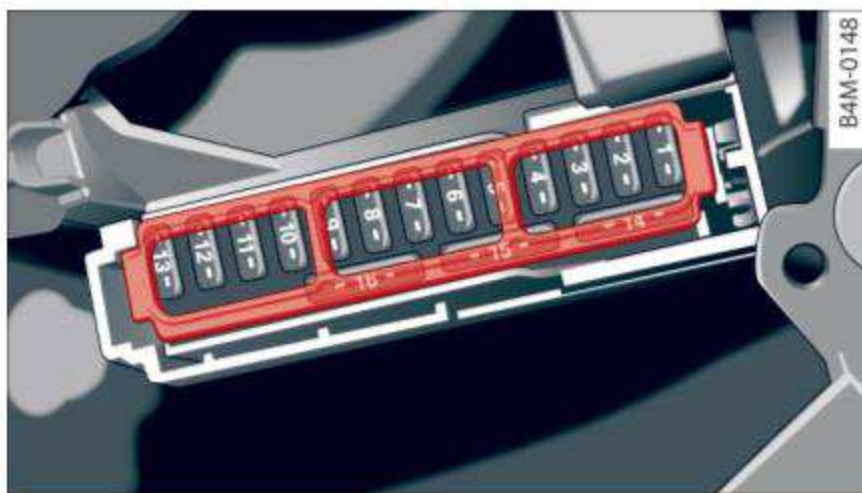

Fig. 284 Driver side cockpit: fuse panel with plastic bracket

**Fuse panel**

No.	Equipment
2	Telephone
4	Head-up display
5	Audi music interface, USB charging port
6	Front climate control system controls
7	Steering column lock
8	Infotainment system display
9	Instrument cluster
10	Infotainment unit
11	Light switch
12	Steering column electronics
14	Infotainment system
15	Power steering column adjustment
16	Steering wheel heating

**Fuse assignment - Left side of the luggage compartment**

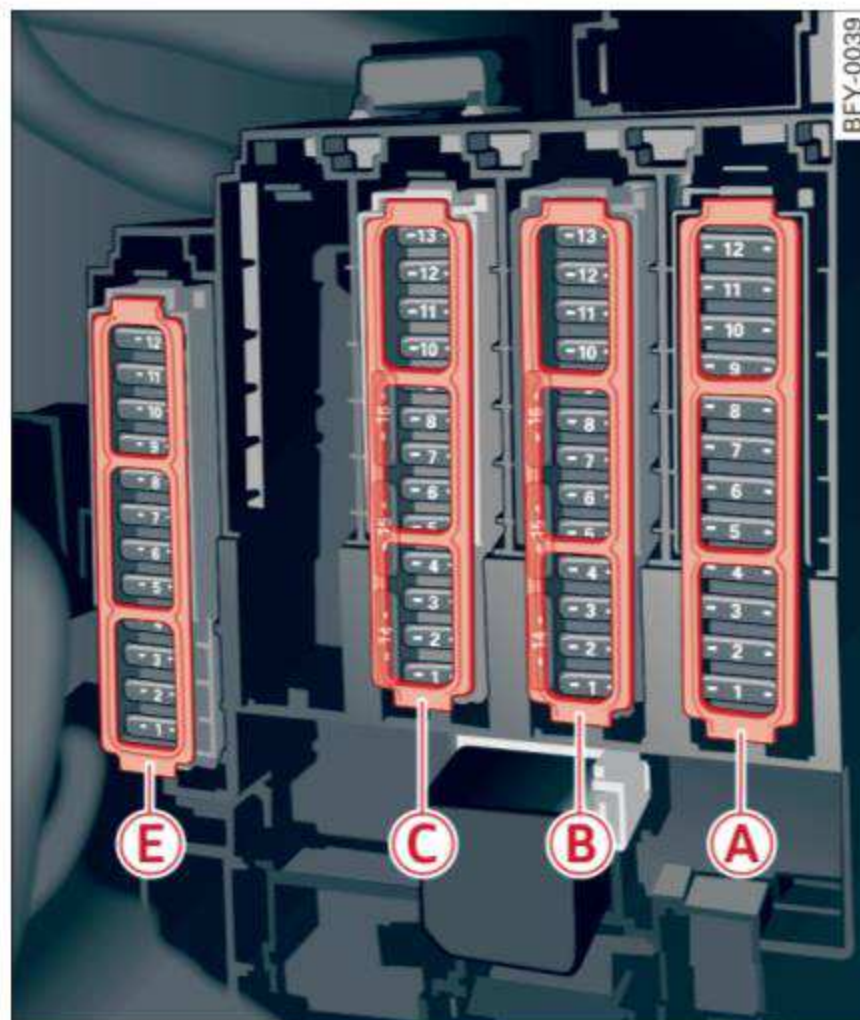

Fig. 285 Left side of the luggage compartment: fuse panel with plastic clip

**Fuse panel (A) (black)**

No.	Equipment
2	Windshield defroster
3	Windshield defroster
5	Air suspension/suspension control
6	Automatic transmission
7	Rear window defogger
8	Rear seat heating
9	Tail lights
10	Left safety belt tensioner
11	Central locking system
12	Electric luggage compartment lid

**Fuse panel (B) (red)**

No.	Equipment
	Not assigned

**Fuse panel (C) (brown)**

No.	Equipment
2	Telephone
3	Lumbar support

Fuse panel  (brown)	
4	Audi side assist
8	Smart module (tank)
9	Climatized cup holder
11	12 Volt battery
12	HomeLink
13	Rearview camera, peripheral cameras
14	Right tail lights
16	Right safety belt tensioner

Fuse panel  (red)	
No.	Equipment
2	Sound-amplifier
3	AdBlue heating
5	Trailer hitch (right light)
7	Trailer hitch
8	Trailer hitch (left light)
9	Trailer hitch (socket)
10	Sport differential
11	AdBlue heating

## Bulbs

### Replacing light bulbs

*For your safety, we recommend that you have your authorized Audi dealer replace any bulbs for you.*

It is becoming increasingly more and more difficult to replace vehicle light bulbs since in many cases, other parts of the car must first be removed before you are able to get to the bulb. This applies especially to the light bulbs in the front of your car which you can only reach through the engine compartment.

Sheet metal and bulb holders can have sharp edges that can cause serious cuts, parts must be correctly taken apart and then properly put back together to help prevent breakage of parts and long term damage from water that can enter housings that have not been properly resealed.

For your safety, we recommend that you have your authorized Audi dealer replace any bulbs for

you, since your dealer has the proper tools, the correct bulbs and the expertise.

### Gas discharge lamps (Xenon lights):

Due to the high electrical voltage, have the bulbs replaced by a qualified technician. Headlights with Xenon light are identified by the high voltage sticker.

### LED headlights\*

LED headlights require no maintenance. Please contact your authorized Audi dealer if a bulb needs to be replaced.

### WARNING

Changing Xenon lamps without the necessary equipment can cause serious personal injury.

- Bulbs are pressurized and can explode when being changed. Potential risk of injury!
- On vehicles equipped with gas discharge bulbs (Xenon light) life-threatening injuries can result from improper handling of the high-voltage portions of such lamps!
- Only your authorized Audi dealer or qualified workshop should change the bulbs in gas discharge lamps. There are parts with sharp edges on the openings and on the bulb holders that can cause serious cuts. If you are uncertain about what to do, have the work performed by an authorized Audi dealer or qualified workshop. Serious personal injury may result from improperly performed work.

### Tips

- If you still prefer to replace the light bulbs yourself, be aware that the engine compartment is a hazardous area to work in ⇒  *in Working in the engine compartment on page 314.*
- It is best to ask your authorized Audi dealer whenever you want to change a bulb.

## Emergency situations

### General

This chapter is intended for trained emergency crews and working personnel who have the necessary tools and equipment to perform these operations.

### Starting by pushing or towing

#### Note

Vehicles with an automatic transmission cannot be started by pushing or towing.

### Starting with jumper cables

*If necessary, the engine can be started by connecting it to the battery of another vehicle.*

If the engine should fail to start because of a discharged or weak battery, the battery can be connected to the battery of *another* vehicle, using a **pair of jumper cables** to start the engine.

#### Jumper cables

Use *only* jumper cables of sufficiently large **cross section** to carry the starter current safely. Refer to the manufacturer's specifications.

Use only jumper cables with *insulated* terminal clamps which are distinctly marked:

**plus (+) cable** in most cases colored **red**

**minus (-) cable** in most cases colored **black**.

#### WARNING

Batteries contain electricity, acid, and gas. Any of these can cause very serious or fatal injury. Follow the instructions below for safe handling of your vehicle's battery.

- Always shield your eyes and avoid leaning over the battery whenever possible.
- A dead battery can freeze at temperatures around 32 °F (0 °C). If the vehicle battery is frozen, you must thaw it before connecting the jump start cables. If you do not, this in-

creases the risk of an explosion and chemical burns. After jump starting the vehicle, drive to an authorized Audi dealer or authorized Audi Service Facility immediately to have the vehicle battery checked.

- Do not allow battery acid to contact eyes or skin. Flush any contacted area with water immediately.
- Improper use of a booster battery to start a vehicle may cause an explosion.
- Vehicle batteries generate explosive gases. Keep sparks, flame and lighted cigarettes away from batteries.
- Do not try to jump start any vehicle with a low acid level in the battery.
- The voltage of the booster battery must also have a 12-Volt rating. The capacity (Ah) of the booster battery should not be lower than that of the discharged battery. Use of batteries of different voltage or substantially different "Ah" rating may cause an explosion and personal injury.
- Never charge a frozen battery. Gas trapped in the ice may cause an explosion.
- Never charge or use a battery that has been frozen. The battery case may have be weakened.
- Use of batteries of different voltage or substantially different capacity (Ah) rating may cause an explosion and injury. The capacity (Ah) of the booster battery should not be lower than that of the discharged battery.
- Before you check anything in the engine compartment, always read and heed all WARNINGS ⇨ page 314.

#### Note

- Applying a higher voltage booster battery will cause expensive damage to sensitive electronic components, such as control units, relays, radio, etc.
- There must be no electrical contact between the vehicles as otherwise current could already start to flow as soon as the positive (+) terminals are connected.

### **i** Tips

The discharged battery must be properly connected to the vehicle's electrical system. When jump starting or charging the battery, never connect the negative ground cable to the battery negative post because the battery manager system must be able to detect the battery's state of charge. Always connect the negative ground cable to the negative ground post of the battery manager control unit.

## Using the jump start cable

*Both jump start cables must be connected in the correct order!*

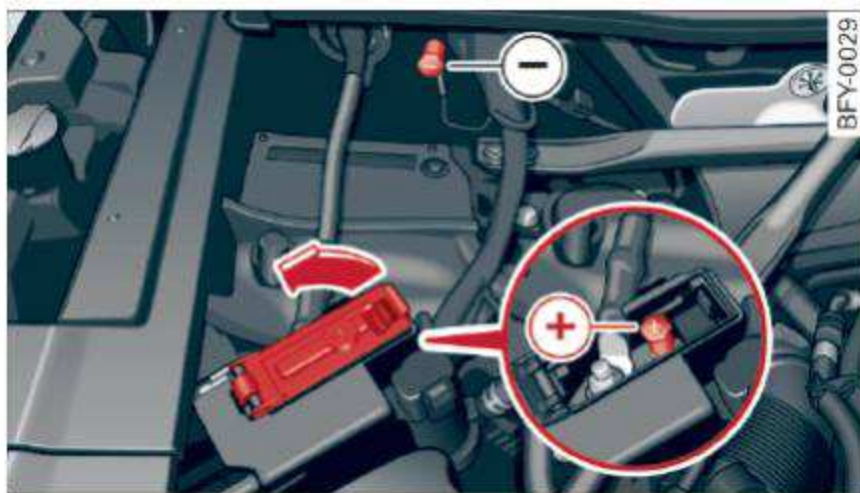

**Fig. 286** Engine compartment: connectors for jump start cables and a charger

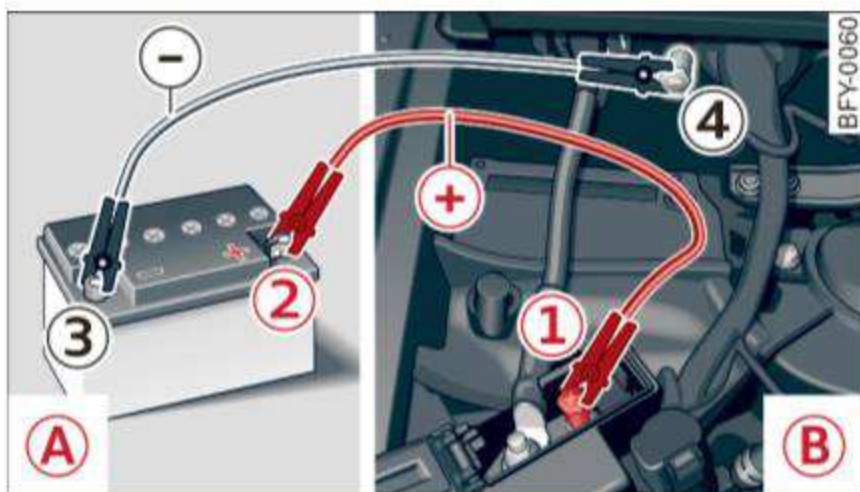

**Fig. 287** Jump starting with a battery in another vehicle:  
**(A)** - providing current, **(B)** - drained

The procedure described below for connecting jumper cables is intended to provide a jump start for your vehicle.

### Vehicle with discharged battery

- ▶ Turn off lights and accessories, move automatic transmission lever to "N" (Neutral) or "P" (Park) and set parking brake.

### Connecting the positive cable (red) to the positive terminal

- ▶ Open the red cover on the positive terminal ⇒ *fig. 286*.
- 1. Secure one end of the positive cable (red) to the jump start pin ⇒ *fig. 287* **(1)** (pin under the red cover = "positive") on the vehicle that needs to be started **(B)**.
- 2. Secure the other end of the positive cable (red) to the positive terminal **(2)** on the battery providing the current **(A)**.

### Connecting the negative cable (black) to the negative terminal

- 3. Secure one end of the negative cable (black) to the negative terminal **(3)** on the battery that is providing the current **(A)**.
- 4. Secure the other end of the negative cable (black) to the jump start pin **(4)** (hex head pin = "negative") on the vehicle that needs to be started **(B)**.

### Starting the engine

- ▶ Start the engine on the vehicle providing the jump start **(A)** and let it run at idle.
- ▶ Now start the engine on the vehicle with the drained battery **(B)**.
- ▶ If the engine does not start, stop the starting procedure after 10 seconds and then repeat it after approximately 30 seconds.
- ▶ Once the engine with the drained vehicle battery has been started, remove the cables in the reverse order from the way they were installed.
- ▶ Close the red cover on the positive terminal.

The battery is vented to the outside to prevent gases from entering the vehicle interior. Make sure that the jumper clamps are well connected with their *metal parts in full contact* with the battery terminals.

### **!** WARNING

To avoid serious personal injury and damage to the vehicle, heed all warnings and instructions of the jumper cable manufacturer. If in doubt, call for road service.

- Jumper cables must be long enough so that the vehicles do not touch.

- When connecting jumper cables, make sure that they cannot get caught in any moving parts in the engine compartment.
- Do not bend over the batteries - danger of chemical burns!
- The battery cell locking screws must be tightened securely.
- Before you check anything in the engine compartment, always read and heed all WARNINGS ⇨ page 314.

### ! Note

Improper hook-up of jumper cables can ruin the generator.

- Always connect POSITIVE (+) to POSITIVE (+), and NEGATIVE (-) to NEGATIVE (-) ground post of the battery manager control unit.
- Check that all screw plugs on the battery cells are screwed in firmly. If not, tighten plugs prior to connecting clamp on negative battery terminal.
- Please note that the procedure for connecting a jumper cable as described above applies specifically to the case of your vehicle being jump started. When you are giving a jump start to another vehicle, do *not* connect the negative (-) cable to the negative (-) terminal on the discharged battery ④ ⇨ fig. 287. Instead, securely connect the negative (-) cable to either a solid metal component that is firmly bolted to the engine block or to the engine block itself. If the battery that is being charged does not vent to the outside, escaping battery gas could ignite and explode!

## Towing with a tow truck

### General hints

Your Audi requires special handling for towing.

The following information is to be used by commercial tow truck operators who know how to operate their equipment safely.

- **Never tow your Audi, towing will cause damage to the engine and transmission.**

- **Never wrap the safety chains or winch cables around the brake lines.**
- **To prevent unnecessary damage, your Audi must be transported with a flatbed truck.**
- **To load the vehicle on to the flatbed, use the towing loop found in the vehicle tools and attach to the front or rear anchorage**  
⇨ page 365 and ⇨ page 366.

### ! WARNING

A vehicle being towed is not safe for passengers. Never allow anyone to ride in a vehicle being towed, for any reason.

### Front towing loop

Only install the front towing loop when it is needed.



Fig. 288 Front bumper: installing the towing loop

The threaded opening for the towing loop is located on the right side of the front bumper.

- ▶ Remove the towing loop from the vehicle tool kit ⇨ page 350.
- ▶ Pull sharply on the trim in the direction of the arrow to remove ⇨ fig. 288.
- ▶ Tighten the towing loop in the threaded opening until it stops and then tighten it with a wheel wrench.
- ▶ After using, place the towing loop back in the vehicle tool kit.

### ! WARNING

If the towing loop is not tightened until it stops when installing, the threads may be pulled out when towing the vehicle and that could cause an accident.

### Note

The trim is attached to the bumper with several hooks. To reduce the risk of damage, do not use any force when removing and installing.

### Rear towing loop

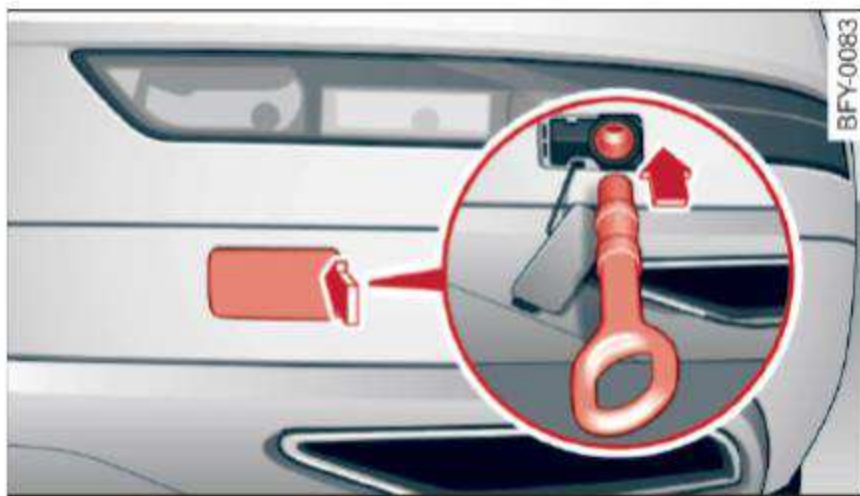

Fig. 289 Rear bumper: installing the towing loop

### Vehicles with a towing loop

On vehicles without a factory-installed trailer hitch\*, the towing loop threads are located on the right rear side of the bumper.

- ▶ Remove the towing loop from the vehicle tool kit ⇒ *page 350*.
- ▶ Press the cap inward with brief, forceful pressure ⇒ *fig. 289*. The cap will loosen from the bumper.
- ▶ Tighten the towing loop in the threaded opening until it stops and then tighten it with a wheel wrench.
- ▶ After using, place the towing loop back in the vehicle tool kit.

### Vehicles with a trailer hitch\*

- ▶ Attach the towing bar or the towing cable to the trailer hitch.

Vehicles with a factory-installed trailer hitch\* are **not** equipped with towing loop threads at the rear.

### WARNING

If the towing loop is not tightened until it stops when installing, the threads may be pulled out when towing the vehicle and that could cause an accident.

### WARNING

Applies to: vehicles with trailer hitch

- Only use a special towing bar to prevent damaging the ball hitch. These towing bars have been specially designed for trailer towing hitches.
- Only use special towing cables.

### Loading the vehicle onto a flatbed truck

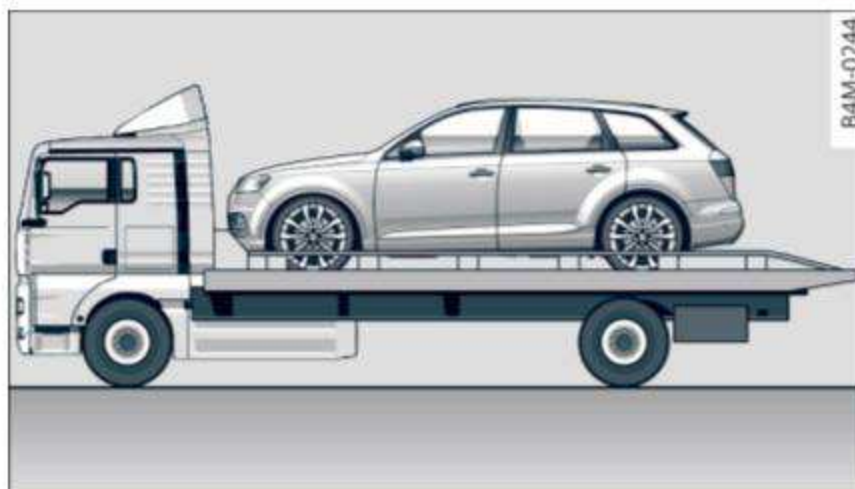

Fig. 290 Vehicle on flatbed truck

### Front hook up

- ▶ Align the vehicle with the centerline of the car carrier ramp.
- ▶ Attach the winch hook to the front towline eye previously installed.

### Rear hook up

- ▶ Align the vehicle with the centerline of the car carrier ramp.
- ▶ Attach the winch hook to the rear towline eye previously installed.

### Tips

Check carefully to make sure the hook-up is secure before moving the car up the flatbed truck ramp.

## Raising the vehicle

### Lifting with workshop hoist and with floor jack

The vehicle may only be lifted at the lifting points illustrated.

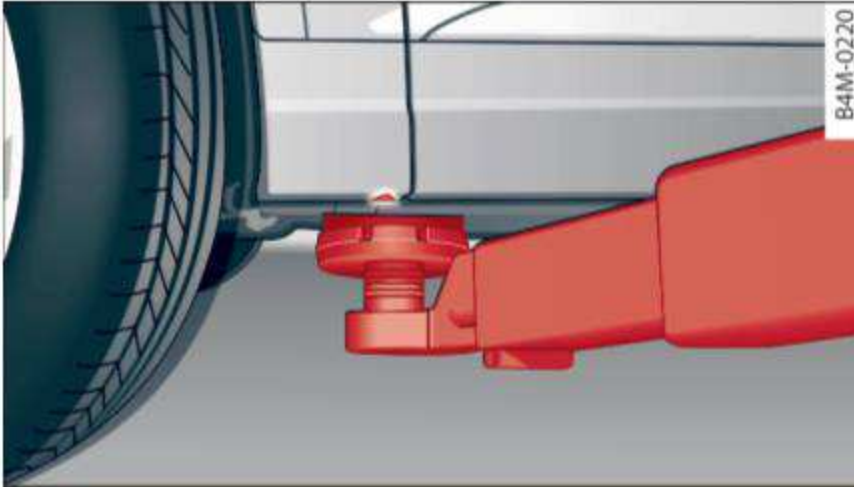

Fig. 291 Front lifting point

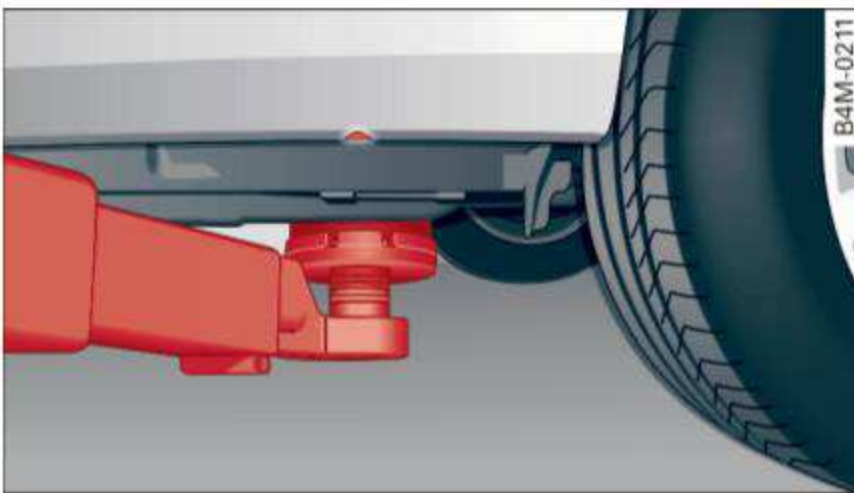

Fig. 292 Rear lifting point

- ▶ Read and heed WARNING ⇒ ⚠.
- ▶ Locate lifting points ⇒ fig. 291 and ⇒ fig. 292.
- ▶ Adjust lifting arms of workshop hoist or floor jack to match vehicle lifting points.
- ▶ Insert a rubber pad between the floor jack/workshop hoist and the lifting points.

If you must lift your vehicle with a floor jack to work underneath, be sure the vehicle is safely supported on stands intended for this purpose.

#### Front lifting point

The lifting point is located on the floor pan reinforcement about at the same level as the jack mounting point ⇒ fig. 291. **Do not lift the vehicle at the vertical sill reinforcement.**

#### Rear lifting point

The lifting point is located on the vertical reinforcement of the lower sill for the onboard jack ⇒ fig. 292.

### Lifting with vehicle jack

Refer to ⇒ page 354.

#### ⚠ WARNING

- To reduce the risk of serious injury and vehicle damage.
- Always lift the vehicle only at the special workshop hoist and floor jack lift points illustrated ⇒ fig. 291 and ⇒ fig. 292.
- Failure to lift the vehicle at these points could cause the vehicle to tilt or fall from a lift if there is a change in vehicle weight distribution and balance. This might happen, for example, when heavy components such as the engine block or transmission are removed.
- When removing heavy components like these, anchor vehicle to hoist or add corresponding weights to maintain the center of gravity. Otherwise, the vehicle might tilt or slip off the hoist, causing serious personal injury.

#### ⓘ Note

- Be aware of the following points before lifting the vehicle:
  - **The vehicle should never be lifted or jacked up from underneath the engine oil pan, the transmission housing, the front or rear axle or the body side members. This could lead to serious damage.**
  - **To avoid damage to the underbody or chassis frame, a rubber pad must be inserted between the floor jack and the lift points.**
  - **Before driving over a workshop hoist, check that the vehicle weight does not exceed the permissible lifting capacity of the hoist.**
  - **Before driving over a workshop hoist, ensure that there is sufficient clearance between the hoist and low parts of the vehicle.**

### Vehicle transport

Applies to: vehicles with air suspension

*The following contains information you should know about transporting your vehicle.*

#### Note

When transporting the vehicle on a car carrier, train, ship or by other means, only tie the vehicle down at the running surface of the tires, which is the outer circumference. Securing the vehicle at the axle components, suspension struts or towing eyes is not permitted because the pressure in the air suspension struts can change during transport. The vehicle may not be secured sufficiently if this happens.

## Technical data

### Vehicle specifications

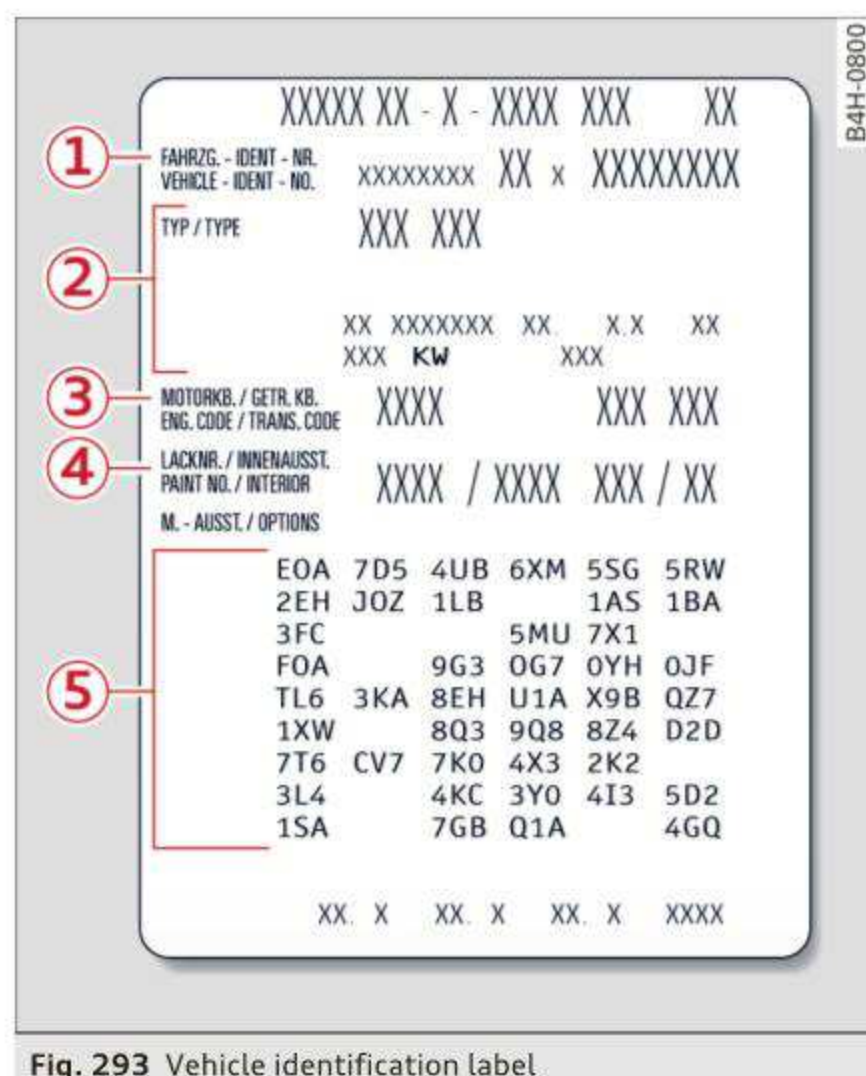

Fig. 293 Vehicle identification label

#### Vehicle Identification Number (VIN)

The VIN number is located in the following places:

- Select: the **MENU** button > **Vehicle** > left control button > **Service & checks** > **Vehicle information**.
- On the vehicle identification label

- At the front behind the windshield\*
- in the engine compartment on the right side

#### Vehicle identification label

The vehicle identification label ⇨ *fig. 293* is located in the luggage compartment under the cargo floor cover.

The vehicle identification label information can also be found in the Warranty and Maintenance booklet.

The sticker contains the following vehicle data:

- 1 Vehicle Identification Number (VIN)
- 2 Vehicle type, engine output, transmission
- 3 Engine and transmission codes
- 4 Paint and interior codes
- 5 Optional equipment numbers

### Notes about technical data

The values may vary based on special equipment as well as market-specific equipment and measuring methods.

Please note that the specifications listed in the vehicle documentation always take precedence.

#### **i** Tips

Missing technical data was not available at the time of printing.

### Dimensions

	Length (in (mm))	Width (in (mm))	Width across the mirrors (in (mm))	Height at curb weight (in (mm))
Q5	183.6 (4,663)	74.5 (1,893)	84.3 (2,140)	65.3 (1,659)
SQ5	183.9 (4,671)	74.5 (1,893)	84.3 (2,140)	65.3 (1,659)

### Capacities

	Approximate capacities
Fuel tank	18.5 gal (70 L)
Windshield and headlight washer system*	5.3 qt (5 L)

## Weights



Fig. 294 Safety certificate

### Gross Vehicle Weight Rating (GVWR)

The maximum permitted total weight ① of the vehicle is listed on the safety certificate on the side area of the door or on the driver's door pillar.

### Trailer load

Trailer without brake	Trailer with brakes up to 12% incline	Tongue weight on trailer ball hitch
1650 lbs (750 kg)	4,400 lbs (2,000 kg)	440 lbs (200 kg)

### Gross Axle Weight Rating (GAWR)

The maximum permitted load on the front axle ② or the rear axle ③ is listed on the safety certificate on the side area of the door or on the driver's door pillar.

### Load

The maximum permitted load is listed on the tire pressure label on the driver's door pillar.

### Roof load

The maximum permissible roof load is 165 lbs (75 kg).

## Consumer Information

### Warranty coverages

Your Audi is covered by the following warranties:

- *New Vehicle Limited Warranty*
- *Limited Warranty Against Corrosion Perforation*
- *Emissions Control System Warranty*
- *Emissions Performance Warranty*
- *California Emissions Control Warranty (USA vehicles only)*
- *California Emissions Performance Warranty (USA vehicles only)*

Detailed information regarding your warranties can be found in your **Warranty & Maintenance booklet**.

### Operating your vehicle outside the U.S.A. or Canada

Government regulations in the United States and Canada require that automobiles meet specific emission regulations and safety standards.

Therefore, vehicles built for the U.S.A. and Canada differ from vehicles sold in other countries.

If you plan to take your vehicle outside the continental limits of the United States or Canada, there is the possibility that:

- unleaded fuels for vehicles with catalytic converter may not be available;
- fuel may have a considerably lower octane rating. Improper fuel may cause engine damage;
- service may be inadequate due to lack of proper service facilities, tools or testing equipment;
- replacement parts may not be readily available.
- Navigation systems for vehicles built for the U.S.A. and Canada will not necessarily work in Europe, and may not work in other countries outside of North America.

#### Note

Audi cannot be responsible for mechanical damage that could result from inadequate fuel, service or parts availability.

### Audi Service Repair Manuals and Literature

Audi Official Factory Service Manuals and Literature are published as soon as possible after model introduction. Service Manuals and literature are available to order from the Audi Technical Literature Ordering Center at:

[www.audi.techliterature.com](http://www.audi.techliterature.com)

### Maintenance

#### General

Your vehicle has been designed to help keep maintenance requirements to a minimum. However, a certain amount of regular maintenance is still necessary to assure your vehicle's safety, economy and reliability. For detailed vehicle maintenance consult your Warranty & Maintenance booklet.

**Under difficult operating conditions**, for example at extremely low outside temperatures, in very dusty regions, when towing a trailer very frequently, etc., some service work should be performed between the intervals specified. This applies particularly to:

- oil changes, and
- cleaning or replacing the air filter.

#### For the sake of the environment

By regularly maintaining your vehicle, you help make sure that emission standards are maintained, thus minimizing adverse effects on the environment.

#### Important considerations for you and your vehicle

The increasing use of electronics, sophisticated fuel injection and emission control systems, and the generally increasing technical complexity of ►

today's automobiles, have steadily reduced the scope of maintenance and repairs which can be carried out by vehicle owners. **Also, safety and environmental** concerns place very strict limits on the nature of repairs and adjustments to engine and transmission parts which an owner can perform.

Maintenance, adjustments and repairs usually require special tools, testing devices and other equipment available to specially trained workshop personnel in order to assure proper performance, reliability and safety of the vehicle and its many systems.

Improper maintenance, adjustments and repairs can impair the operation and reliability of your vehicle and even void your vehicle warranty.

Therefore, proof of servicing in accordance with the maintenance schedule may be a condition for upholding a possible warranty claim made within the warranty period.



Above all, operational safety can be adversely affected, creating unnecessary risks for you and your passengers.

If in doubt about any servicing, have it done by your authorized Audi dealer or any other properly equipped and qualified workshop. We strongly urge you to give your authorized Audi dealer the opportunity to perform all scheduled maintenance and necessary repairs. Your dealer has the facilities, original parts and trained specialists to keep your vehicle running properly.

### Performing limited maintenance yourself

The following pages describe a limited number of procedures which can be performed on your vehicle with ordinary tools, should the need arise and trained personnel be unavailable. Before performing any of these procedures, always thoroughly read all of the applicable text and carefully follow the instructions given. Always rigorously observe the **WARNINGS** provided.

**Before you check anything in the engine compartment, always read and heed all WARNINGS**

⇒  **and** ⇒  *in Working in the engine compartment on page 314.*

### **WARNING**

- Serious personal injury may occur as a result of improperly performed maintenance, adjustments or repairs.
- Always be extremely careful when working on the vehicle. Always follow commonly accepted safety practices and general common sense. Never risk personal injury.
- Do not attempt any of the maintenance, checks or repairs described on the following pages if you are not fully familiar with these or other procedures with respect to the vehicle, or are uncertain how to proceed.
- Do not do any work without the proper tools and equipment. Have the necessary work done by your authorized Audi dealer or another properly equipped and qualified workshop.
- The engine compartment of any motor vehicle is a potentially hazardous area. Never reach into the area around or touch the radiator fan. It is temperature controlled and can switch on suddenly - even when the engine is off and the ignition key has been removed. The radiator fan switches on automatically when the coolant reaches a certain temperature and will continue to run until the coolant temperature drops.
- Always remove the ignition key before anyone gets under the vehicle.
- Always support your vehicle with safety stands if it is necessary to work underneath the vehicle. The jack\* supplied with the vehicle is not adequate for this purpose and could collapse causing serious personal injury.
- If you must work underneath the vehicle with the wheels on the ground, always make sure the vehicle is on level ground, that the wheels are always securely blocked and that the engine cannot be started.
- Always make sure the transmission selector lever (automatic transmission) is in P (Park position) and the park brake is applied.

**For the sake of the environment**

- Changing the engine settings will adversely affect emission levels. This is detrimental to the environment and increases fuel consumption.
- Always observe environmental regulations when disposing of old engine oil, used brake fluid, dirty engine coolant, spent batteries or worn out tires.
- Undeployed airbag modules and pretensioners might be classified as Perchlorate Material -special handling may apply, see [www.dtsc.ca.gov/hazardouswaste/perchlorate](http://www.dtsc.ca.gov/hazardouswaste/perchlorate). When the vehicle or parts of the restraint system including airbag modules safety belts with pretensioners are scrapped, all applicable laws and regulations must be observed. Your authorized Audi dealer is familiar with these requirements and we recommend that you have your dealer perform this service for you.

## Accessories and technical changes

### Additional accessories and parts replacement

*Always consult an authorized Audi dealer before purchasing accessories.*

Audi vehicles that are constructed with advanced materials like Steel/Aluminum (Hybrid construction), Aluminum (Audi Space Frame), and/or Aluminum/Carbon Fiber (Ultra Advanced Light Weight Materials) are as unique as their drivers. Therefore, the availability of certain parts needed for repair, restoration, or reconstruction will be restricted, or parts will be unavailable, if the vehicle is not repaired at an authorized Audi collision repair facility. This includes but is not limited to structural parts which require specialized training and equipment to restore their crash-worthiness back to the original NHTSA and IIHS performance.

Your vehicle incorporates the latest safety design features ensuring a high standard of active and passive safety.

This safety could be compromised by non-approved changes to the vehicle. For this reason, if parts have to be replaced, please observe the following points when installing additional accessories:

Approved Audi accessories and genuine Audi parts are available from authorized Audi dealers.

These dealers also have the necessary facilities, tools and trained specialists to install the parts and accessories properly.

**WARNING**

Using the wrong spare parts or using non-approved accessories can cause damage to the vehicle and serious personal injury.

- Use only accessories expressly approved by Audi and genuine Audi spare parts
- These parts and accessories have been specially designed to be used on your vehicle.
- Do not use license plate brackets in the front area that are different from the one installed at the factory, or add additional license plate brackets.
- Never install accessories such as telephone cradles or beverage holders on airbag covers or within the airbag deployment zones. Doing so will increase the risk of injury if airbags are triggered in an accident!
- Before you check anything in the engine compartment, always read and heed all WARNINGS ⇨ *page 314*.

**Note**

- If items other than genuine Audi spare parts, add-on equipment and accessory items are used or if repair work is not performed according to specified methods, this can result in severe damage to your vehicle's engine and body (such as corrosion) and adversely affect your vehicle's warranty.
- If emergency repairs must be performed elsewhere, have the vehicle examined by an authorized Audi dealer as soon as possible.
- The manufacturer cannot be held liable for damage which occurs due to failure to comply with these stipulations.

### Technical Modifications

*Our guidelines must be complied with when technical modifications are made.*

Always consult an authorized Audi dealer **before** starting work on any modifications.

This will help ensure that vehicle function, performance and safety are not impaired ⇒ ⚠.

Attempting to work on electronic components and the software used with them can cause malfunctions. Because of the way electronic components are interconnected with each other, such malfunctions can also have an adverse effect on other systems that are not directly involved. This means that you risk both a substantial reduction in the operational safety of your vehicle and an increased wear of vehicle parts ⇒ ⚠.

Authorized Audi dealers will perform this work in a professional and competent manner or, in special cases, refer you to a professional company that specializes in such modifications.

#### **WARNING**

Improper repairs and modifications can change the way vehicle systems work and cause damage to the vehicle and serious personal injury.

#### **Note**

If emergency repairs must be performed elsewhere, have the vehicle examined by an authorized Audi dealer as soon as possible.

## Declaration of compliance for telecommunications equipment and electronic systems

The manufacturer is not liable for radio malfunctions that are caused by unauthorized changes to the equipment.

### Equipment

The following equipment complies with FCC section 15 and RSS-Gen:

- Audi adaptive cruise control\*
- Audi side assist\*
- Remote control key
- Garage door opener (HomeLink)\*
- Cell phone package\*

### FCC Part 15.19

This device complies with part 15 of the FCC Rules. Operation is subject to the following two conditions: (1) This device may not cause harmful interference, and (2) this device must accept any interference received, including interference that may cause undesired operation.

### FCC Part 15.21

Changes or modifications not expressly approved by the party responsible for compliance could void the user's authority to operate the equipment.

### RSS-Gen

This device complies with Industry Canada's licence-exempt RSSs. Operation is subject to the following two conditions:

- (1) This device may not cause interference; and
- (2) This device must accept any interference, including interference that may cause undesired operation of the device.

### CNR-Gen

Le présent appareil est conforme aux CNR d'Industrie Canada applicables aux appareils radio exempts de licence. L'exploitation est autorisée aux deux conditions suivantes :

- 1) l'appareil ne doit pas produire de brouillage;
- 2) l'appareil doit accepter tout brouillage radioélectrique subi, même si le brouillage est susceptible d'en compromettre le fonctionnement.

- A**
- A/C MAX (button) ..... 71
  - A/C (button) ..... 70
  - ABS ..... 140
  - Accessories ..... 60, 373
  - Active lane assist
    - Cleaning the camera area ..... 345
    - also refer to Audi active lane assist* ..... 117
  - Adaptive air suspension
    - refer to Air suspension* ..... 125
  - Adaptive cruise control ..... 102
    - Cleaning the sensors ..... 345
    - Messages ..... 110
    - Predictive control ..... 100
  - Adaptive dampers ..... 125
  - Additional accessories ..... 373
  - Adjusting air distribution (automatic climate control) ..... 71
  - Adjusting the additional display ..... 14
  - Adjusting the sound ..... 249
  - Adjusting the temperature (automatic climate control) ..... 71
  - Adjusting the volume ..... 14
  - Advanced key
    - refer to Convenience key* ..... 76
  - Airbag ..... 269
  - Airbag system ..... 269, 287
    - Advanced Airbag System components ... 276
    - Care ..... 284
    - Children ..... 293
    - Child restraints ..... 293
    - Components (front airbags) ..... 276
    - Danger of fitting a child safety seat on the front passenger seat ..... 270
    - Disposal ..... 284
    - Front airbags ..... 274
    - How do the front airbags work? ..... 279
    - How many airbags does my vehicle have? 276
    - How the Advanced Airbag System components work together ..... 278
    - Indicator light ..... 281
    - Monitoring ..... 281
    - PASSENGER AIR BAG light ..... 281
    - Repairs ..... 284
    - Safety instructions ..... 283
    - When must the system be inspected? ... 281
  - Air suspension ..... 125
  - Alarm system
    - refer to Anti-theft alarm system* ..... 36
  - Alignment pin (changing the wheel) ..... 350
  - All-weather lights ..... 45
  - All season tires ..... 340
  - All wheel drive
    - Indicator light ..... 28
    - also refer to quattro* ..... 144
  - AMI
    - refer to Audi music interface* ..... 231, 232
  - Android Auto
    - refer to Audi smartphone interface* ..... 243
  - Anti-freeze
    - Windshield washer system ..... 323
  - Anti-Lock Braking System
    - refer to ABS* ..... 140
  - Anti-Slip Regulation
    - refer to ASR* ..... 140
  - Anti-theft alarm system ..... 36
  - Apple CarPlay
    - refer to Audi smartphone interface* ..... 243
  - Arrow view ..... 164
  - ASR ..... 140
  - Audi active lane assist ..... 117
    - Messages ..... 118
  - Audi adaptive cruise control
    - Distance display, distance warning ..... 110
    - Traffic jam assist ..... 109
  - Audi connect emergency call and service .. 201
    - Online roadside assistance ..... 202
  - Audi connect vehicle control ..... 197
    - Parking location ..... 198
    - Remote locking and unlocking ..... 198
    - Vehicle status report ..... 198
  - Audi connect (Infotainment) ..... 187, 194
    - Data protection ..... 195
    - Services overview ..... 188
    - Starting ..... 188
  - Audi drive select ..... 125
  - Audi Entertainment mobile ..... 234
  - Audi music interface ..... 231
  - Audi music stream
    - refer to Wi-Fi* ..... 229
  - Audio files ..... 234

Audio player		
Bluetooth audio player	.....	228
Wi-Fi audio player	.....	229
Audio track	.....	237
Audi pre sense	.....	112
Messages	.....	116
Settings	.....	116
Audi Service Repair Manuals and Literature		371
Audi side assist	.....	120
Rear cross-traffic assist	.....	124
Audi smartphone interface	.....	243, 247
Audi virtual cockpit		
<i>refer to</i> Instrument cluster	.....	10
AUTO		
Automatic headlights	.....	45
Auto Lock (central locking system)	.....	30
Automatic belt retractor	.....	264
Automatic climate control	.....	69
Operation	.....	70
Automatic climate control system		
Audi drive select	.....	125
Setup	.....	72
Automatic transmission	.....	84
Emergency program	.....	89
Hill descent control	.....	87
Kick-down	.....	88
Launch control program	.....	89
Manual shifting	.....	88
Parking lock emergency release	.....	90
Selector lever positions	.....	85
Automatic wipe/wash system	.....	51
Auto Safety Hotline	.....	259
AUTO (button)		
Automatic climate control system	.....	71
Auxiliary heater (automatic climate control)		72
AUX input	.....	232
Average consumption	.....	16
Average speed	.....	16
<b>B</b>		
BACK button	.....	147
Balance (sound)	.....	249
Bass (sound)	.....	249
Battery		
Jump starting	.....	363
<i>also refer to</i> Vehicle battery	.....	321
Before driving	.....	252
Belt tensioners	.....	267
Blended gasoline	.....	310
Blower (automatic climate control system)		71
Bluetooth		
Audio player	.....	228
Connecting a cell phone	.....	174
Settings	.....	248
Boost	.....	17
Booster seats	.....	301
Boost pressure indicator	.....	17
Brake fluid		
Checking the brake fluid level	.....	321
Brakes	.....	142
Brake assist	.....	140
Brake fluid	.....	321
Electromechanical parking brake	.....	80
Emergency braking function	.....	81
New brake pads	.....	142
Worn brake pads	.....	26
Break-in security feature	.....	36
Breaking in		
New brake pads	.....	142
New engine	.....	73
New tires	.....	332
Browser		
<i>refer to</i> Media center	.....	235
Bulbs	.....	362
Buttons		
Control panel (MMI)	.....	148
Multifunction steering wheel	.....	12, 15
Switching the Infotainment system display on/off	.....	148
<b>C</b>		
Cable (USB adapter/AUX connector cable)		231
California Proposition 65 Warning	.....	315
Battery specific	.....	322
Call list	.....	177
Call options	.....	185
Capacities		
Fuel tank	.....	369
Washer fluid reservoir	.....	369
Cargo area		
<i>refer to</i> Loading the luggage compartment	.....	257

Cargo floor	66	Safety instructions	295
Cargo mat	66	Securing	302
Catalytic converter	313	Unused safety belts on the rear seat	297
CD drive (media drives)	227	Child seats	
Cell phone		Lower anchorages	306
<i>refer to Telephone</i>	174	Classic view	14
Center armrest	57	Cleaning	344
Central locking	30	Cleaning Alcantara	347
Convenience key	33	Cleaning artificial leather	347
Mechanically locking	35	Cleaning carbon parts	346, 347
Power windows	41	Cleaning controls	346
Remote control key	33	Cleaning decorative parts/trim	346
Setting	35	Cleaning exhaust tail pipes	346
Central locking switch	34	Cleaning plastic parts	346
Certification	374	Cleaning textiles	347
Changing engine oil	319	Climate control system	
Changing the scale	13	<i>refer to Automatic climate control</i>	69
Charging		Clock	16, 245
<i>refer to Power sources</i>	60	Closing	
Charging the battery (mobile devices)	232, 233	Hood	315
Child restraints		Cockpit (overview)	8
Danger of using child restraints in the front seat	270	Collapsible spare tire	
Where can I get additional information about child restraints and their use?	309	Inflating	356
Child restraint system anchors	305	Collapsible tire	
Child safety	291	<i>refer to Collapsible spare tire</i>	356
Important safety instructions for using child safety seats	295	Command (voice recognition system)	167
Installing a child restraint using the LATCH system	307	Compartments	60
Mounting and releasing the anchorage hook	307	Compass in the mirror	54
Tether anchors	308	Compliance	374
Tether straps	308	Connection manager	246
Child safety lock		Connections	
Power windows	40	<i>refer to Media</i>	225, 234
Rear doors	40	Connect (vehicle control)	197
Child safety seats	297	Consumer Information	259, 371
Booster seats	301	Consumption (fuel)	16
Convertible child seats	299	Contacting NHTSA	259
Danger of using child restraints in the front seat	270	Contacts	183
How do I properly install a child safety seat in my vehicle?	295	Additional directory	247
Infant seats	297	Importing/exporting	184
LATCH system	307	Memory capacity	185
		Storing as destination	211
		Control buttons (operating the MMI)	150
		Control knob with joystick function (MMI operation)	153

Convenience key		
Switching the ignition on	76	
Unlocking/locking	33	
Convenience opening/closing	41	
Convertible child safety seats	299	
Convertible locking retractor		
Activating	304	
Deactivating	305	
Using to secure a child safety seat	304	
Cooled glove compartment	61	
Cooling mode (automatic climate control system)	70, 71	
Cooling system		
Adding coolant	320	
Coolant	319	
Coolant level checking	320	
Coolant temperature indicator	11	
Crosshairs	205	
Cruise control system	95	
Cup holders	60	
Current consumption	16	
<b>D</b>		
Data connection	194	
Data protection	195	
Data recorder	145	
Date	16, 245	
Date display	245	
Daytime running lights	45	
Declaration of compliance	374	
Defrosting (windows)	71	
DEF (instrument cluster)	12	
Demo mode		
<i>refer to</i> Presentation mode	211	
Destination on the map		
Using the MMI touch	205	
Determining correct load limit	339	
Digital compass	54	
Digital Rights Management	225	
Dimensions	369	
Dimming the exterior mirrors	50	
Dimming the rearview mirror	50	
Directory		
<i>refer to</i> Contacts	183	
Display	12	
Cleaning	346	
Infotainment system display	148, 246	
Instrument cluster	15	
Multifunction steering wheel	12	
Versions (MMI)	148	
Distance	16	
Doors		
Mechanically locking	35	
Driver information system		
Changing views	12	
Energy consumers	17	
Outside temperature display	10	
Service interval display	324	
Trip computer	16	
View	14	
Driver seat		
<i>refer to</i> Seating position	253	
Drives		
<i>refer to</i> Media	225, 234	
Drive select		
<i>refer to</i> Audi drive select	125	
Driving economically	73	
Driving offroad	82	
Driving on hills	83	
Driving safely	252	
Driving through water	73	
Driving time	16	
DVD drive (media drives)	226	
Dynamic steering	125	
Dynamic volume		
<i>refer to</i> System volume	250	
<b>E</b>		
E-mail	181	
Easy seat entry	76	
Economical route	210	
eco (button)	70	
EDS	140	
Electromechanical parking brake	80	
Electromechanical steering	144	
Electronic immobilizer	31	
Electronic Stabilization Control		
<i>refer to</i> ESC	140, 141	
Emergency assistance	350	
Emergency braking function	81	

- Emergency call function  
 Audi connect emergency call and service . 201
- Emergency flashers . . . . . 47
- Emergency operation  
 Fuel filler door . . . . . 313
- Emergency starting . . . . . 363
- Emissions control system . . . . . 313
- Energy management . . . . . 145
- Engine  
 Coolant . . . . . 319  
 Start/Stop system . . . . . 78  
 Starting/stopping . . . . . 76  
 Starting with jumper cables . . . . . 363
- Engine compartment  
 Opening/closing the hood . . . . . 315  
 Overview . . . . . 316  
 Safety precautions . . . . . 314
- Engine oil  
 Adding . . . . . 317  
 Changing . . . . . 319  
 Checking oil level . . . . . 317  
 Consumption . . . . . 317  
 Temperature display . . . . . 17
- Engine sound . . . . . 125
- Engine Start/Stop mode  
*refer to* Start/Stop system . . . . . 78, 80
- Engine stop  
*refer to* Start/Stop system . . . . . 78, 80
- Enhanced view . . . . . 14
- Entering characters/numbers (speller) . . . . 155
- Entering letters (speller) . . . . . 155
- Entertainment sliding menu . . . . . 153
- Entry/exit lighting . . . . . 47
- Environment  
 Proper disposal of drained engine oil . . . . 319  
 Unleaded gasoline . . . . . 310
- ESC . . . . . 140  
 Hill descent assist . . . . . 142  
 Offroad mode . . . . . 141
- Evasive steering support . . . . . 113
- Event Data Recorder (EDR) . . . . . 145
- Exterior lighting . . . . . 45
- Exterior mirrors . . . . . 49
- External voice operation . . . . . 172
- F**
- Factory default settings  
 Multi Media Interface . . . . . 246
- Fader (sound) . . . . . 249
- Fastening  
 Booster seats . . . . . 301  
 Convertible child safety seats . . . . . 299  
 Infant seats . . . . . 297
- Fast forwarding/rewinding (audio/video file) . . . . . 234
- Fast forwarding (audio/video file) . . . . . 234
- Fast route . . . . . 210
- Favorites  
 Media . . . . . 237  
 Navigation . . . . . 205  
 Telephone . . . . . 179
- Federal Communications Commission (FCC) 374
- File formats (media drives) . . . . . 240
- Fixture set . . . . . 65
- Floor mats . . . . . 257
- Foot pedals . . . . . 256
- For the sake of the environment  
 Environmentally-friendly driving . . . . . 73  
 Fueling . . . . . 311  
 Leaks . . . . . 315  
 Warming up the engine . . . . . 76
- Free text search . . . . . 157  
 Media . . . . . 236  
 Navigation . . . . . 204  
 Radio . . . . . 221  
 Telephone . . . . . 183
- Freeze protection  
 Coolant . . . . . 319
- Frequency band . . . . . 220, 223
- Front airbags  
 Description . . . . . 273  
 How they work . . . . . 279
- Frontal collisions and the laws of physics . . 262
- Front seats  
 Adjusting . . . . . 254  
 Child restraints in the front seat . . . . . 270  
*also refer to* Seats . . . . . 56
- Fuel . . . . . 310  
 Additives . . . . . 310  
 Blended gasoline . . . . . 310

Current consumption . . . . . 16  
 Fuel gauge . . . . . 10, 12  
 Fuel tank capacity . . . . . 369  
 Gasoline . . . . . 310  
 Gasoline additives . . . . . 311  
 Saving fuel . . . . . 73, 125

Fueling

Fuel filler door emergency release . . . . . 313  
 Fuel gauge . . . . . 12  
 Fuel tank capacity . . . . . 369  
 Opening the fuel filler door . . . . . 311

Fuses

Assignment . . . . . 359  
 Replacing . . . . . 358

**G**

Garage door opener  
*refer to* HomeLink . . . . . 43

Garment hooks . . . . . 61

Gas discharge lamps . . . . . 362

Gasoline . . . . . 310  
 Octane rating . . . . . 310  
 Recommendation . . . . . 310

GAWR  
*refer to* Gross Axle Weight Rating (GAWR) 370

Glossary of tire and loading terminology . . 328

Glove compartment . . . . . 61

Gross Axle Weight Rating (GAWR) . . . . . 370

Gross Vehicle Weight Rating (GVWR) . . . . 370

Ground clearance . . . . . 83

GVWR  
*refer to* Gross Vehicle Weight  
 Rating (GVWR) . . . . . 370

**H**

Handsfree . . . . . 174

Head-up display . . . . . 18

Headlight range control system . . . . . 45

Headlights . . . . . 45  
 Cleaning . . . . . 345  
 Headlight range control system . . . . . 45  
 Washer system . . . . . 51

Head restraints . . . . . 58, 255  
 Adjusting . . . . . 255

Heating . . . . . 69

Heavy clothing and safety belts . . . . . 263

High beams . . . . . 46  
 Assistant . . . . . 46

Hill descent assist . . . . . 142

Hill descent control . . . . . 87

Hill hold assist . . . . . 82  
*also refer to* Hill hold assist . . . . . 82

Home address . . . . . 205, 210

HomeLink . . . . . 43

Horn . . . . . 8

How are child restraint system anchors related to child safety . . . . . 305

How many airbags does my vehicle have? . . 276

How safety belt pretensioners work . . . . . 267

**I**

Imbalance (wheels) . . . . . 334

Immobilizer . . . . . 31

Important things to do before driving . . . . 252

Importing and exporting (contacts) . . . . . 184

Improperly worn safety belts . . . . . 267

Indicator lights . . . . . 19  
 Airbag system . . . . . 281  
 PASSENGER AIR BAG . . . . . 281

Infant seats . . . . . 297

Input  
 Using the MMI touch . . . . . 151  
 Using the speller . . . . . 155

Input level (media) . . . . . 237

Inspection interval . . . . . 324

Installing the upper tether strap on the anchorage . . . . . 308

Instrument cluster . . . . . 10  
 Cleaning . . . . . 346  
 Messages . . . . . 19

Instrument illumination . . . . . 49

Interior lighting . . . . . 48

Interior monitoring . . . . . 36

Internet  
*refer to* Audi connect (Infotainment) . . . . 187

Internet radio . . . . . 230

Interval mode (wipers) . . . . . 51

iPhone  
*refer to* Audi music interface . . . . . 231, 232

- J**
- Jukebox ..... 227
  - Jump-starting ..... 363
  - Jump start cable ..... 364
- K**
- Key ..... 31
    - Key not recognized ..... 78
    - Key replacement ..... 31
    - Mechanical key ..... 31, 32
    - Replacing the battery ..... 32
    - Unlocking/locking ..... 33, 35
    - Vehicle code ..... 31
  - Kick-down (automatic transmission) ..... 88
- L**
- Lane assist
    - refer to Audi active lane assist* ..... 117
  - Lap timer ..... 98
    - Evaluating ..... 99
    - Starting ..... 99
  - LATCH ..... 305
    - Description ..... 306
    - Installing a child restraint ..... 307
    - Location ..... 306
    - Mounting and releasing the anchorage hook ..... 307
  - Launch control program ..... 89
  - Leather care/cleaning ..... 347
  - Left control button ..... 13
  - Licensing agreements (MMI) ..... 250
  - Lifting points (vehicle jack) ..... 354
  - Light/rain sensor
    - Headlights ..... 45
    - Interval mode (wipers) ..... 51
  - Light functions ..... 45
    - High beam assistant ..... 46
    - Instrument illumination ..... 49
    - Interior lighting ..... 48
  - Lighting
    - Exterior ..... 45
    - Interior ..... 48
  - Lights
    - Headlight range control system ..... 45
  - Listening to music
    - refer to Media* ..... 225, 234
  - Load ..... 370
  - Loading the luggage compartment ..... 257
  - Locking/unlocking
    - By remote control ..... 33
    - With the convenience key ..... 33
    - With the lock cylinder ..... 35
  - Low beam headlights ..... 45
  - Lowering the rear of the vehicle ..... 128
  - Luggage compartment ..... 62
    - Cover (manual) ..... 62
    - Power sources ..... 60
    - Storing cargo correctly ..... 257
    - Tie-downs ..... 65
      - also refer to Loading the luggage compartment* ..... 257
  - Luggage compartment lid ..... 36
    - Emergency release ..... 40
  - Lumbar support ..... 56
- M**
- Maintenance ..... 371
  - Maintenance intervals ..... 324
  - Making an emergency call ..... 179
  - Malfunction Indicator Lamp (MIL) ..... 313
  - Map
    - Display ..... 218
    - Operating ..... 213
    - Settings ..... 214
    - Update ..... 203
  - Map update ..... 216
  - Mechanical key ..... 31, 32
  - Mechanically locking the front passenger's door ..... 35
  - Media ..... 225, 234
    - Drives ..... 226
    - Supported formats ..... 240
  - Media center ..... 235
  - Memory buttons
    - refer to Shortcut keys* ..... 147, 155
  - Memory capacity
    - Directory ..... 184
    - Jukebox ..... 227

Memory card		
SD card reader (MMI)	226	
Supported types/formats	240	
Memory function	59	
MENU button	147	
Menu language		
<i>refer to</i> Setting the language	245	
Menu paths (Owner's Manual)	150	
Menus/symbols	158	
Messages	180	
Mirrors		
Adjusting exterior mirrors	49	
Compass	54	
Dimming	50	
Vanity mirror	51	
MMI		
<i>refer to</i> Multi Media Interface	147	
MMI search		
<i>refer to</i> Free text search	157, 236	
MMI touch	151	
MODE button	15	
Monitoring the Advanced Airbag System	281	
MP3		
<i>refer to</i> Jukebox	227	
Multifunction steering wheel	160	
Button	14	
Map zoom	13	
Operating	12, 15	
Speech dialog system	14	
Switching tabs	12, 15	
Multi Media Interface	148	
Music collection		
<i>refer to</i> Jukebox	227	
Mute	14	
<i>also refer to</i> Muting	249	
Muting	14, 249	
myAudi	187, 207	
Logging in in the vehicle	187	
PIN	187	
<b>N</b>		
Natural leather care/cleaning	347	
NAV/MAP button	203	
Navigating (instrument cluster)	163	
Navigation	203	
Announcements	212	
Better route	218	
Driver information system	164	
<i>also refer to</i> Map	213	
Navigation (instrument cluster)	162	
Net	61	
Network connection (Wi-Fi)	193	
NHTSA		
Contacting	259	
Number of seats	261	
<b>O</b>		
Occupant protection	112	
Occupant seating positions	253	
Octane rating (gasoline)	310	
Odometer	12	
Offroad driving	82	
Offroad mode	141	
OFF (button)	70	
Oil		
<i>refer to</i> Engine oil	317	
On-Board Diagnostic System (OBD)	313	
On/Off knob (MMI)	148	
Online destinations		
<i>refer to</i> Point of interest search	207	
Online map	215	
Online map update	216	
Online media	230	
Online roadside assistance		
Audi connect emergency call and service	202	
Online services		
<i>refer to</i> Audi connect (Infotainment)	187	
Opening	30	
Fuel filler door	311	
Hood	315	
Opening/closing		
<i>refer to</i> Unlocking/locking	30	
Operating		
Multifunction steering wheel	12, 15	
Multi Media Interface	149	
Voice recognition system	167	
Options menu	150, 154	
Other consumers	17	
Outside temperature display	10	

- Overview (Cockpit) ..... 8
- P**
- Paint damage ..... 346
- Paint number ..... 369
- Panorama glass roof ..... 42
- Emergency operation ..... 42
- Parental control
- DVD ..... 237
- Park assist
- Cleaning the sensors/camera ..... 345
- Parking aid ..... 130
- Parking brake
- refer to* Electromechanical parking brake . . . 80
- Parking lights ..... 45
- Parking location
- Audi connect vehicle control ..... 198
- Parking system
- refer to* Parking systems ..... 131, 133
- Parking systems
- Peripheral cameras ..... 135
- Rearview camera ..... 133
- Settings ..... 138
- Trailer hitch ..... 139
- Partition net ..... 64
- Parts replacement ..... 373
- PASSENGER AIR BAG light ..... 281
- Pause (audio/video file) ..... 234
- Pedals ..... 256
- Personal route assistance ..... 209
- Phonebook
- refer to* Contacts ..... 183
- Physical principles of a frontal collision . . . 262
- Picture format (video) ..... 237
- Pitch angle ..... 83
- Playback (media) ..... 234
- Playlist ..... 237
- Point of interest ..... 206
- Point of interest search ..... 207
- also refer to* Point of interest ..... 206
- Polishing ..... 346
- Pollutant filter (automatic A/C system) .... 69
- Power sources ..... 60, 232, 233
- Predictive efficiency assist ..... 100
- Pregnant women
- Special considerations when wearing a safety belt ..... 266
- pre sense
- refer to* Audi pre sense ..... 112
- Presentation mode ..... 212
- Presets (radio) ..... 223
- Pressure
- Tire pressure monitoring system ..... 342
- Tires ..... 335
- Program guide
- Radio ..... 221
- Programming buttons (multifunction steering wheel) ..... 14
- Proper occupant seating positions ..... 253
- Proper safety belt position ..... 265
- Proper seating position
- Front passenger ..... 254
- Occupants ..... 253
- Rear passengers ..... 254
- Protecting ..... 346
- Q**
- quattro ..... 144
- Selective wheel torque control ..... 140
- Question
- What happens to unbelted occupants? . . 262
- R**
- Radio ..... 220
- Additional station information ..... 222
- Presets ..... 223
- Radio text ..... 221
- Station list ..... 220
- Radio Standards Specification (RSS) ..... 374
- Rail carrier ..... 368
- Rain/light sensor
- Headlights ..... 45
- Interval mode (wipers) ..... 51
- Raising the vehicle ..... 367
- Random
- refer to* Shuffle ..... 237
- Range (fuel level) ..... 16
- Reading lights ..... 48
- Rear fog lights ..... 45

Rear lid		
<i>refer to</i> Luggage compartment lid	....	36, 37
Rear lowering	.....	128
Rear Seat Entertainment preparation		
<i>refer to</i> Audi Entertainment mobile	....	234
Rearview camera		
<i>refer to</i> Parking systems	.....	131, 133
Rear window defogger	.....	71
Rear window washer system	.....	51
REAR (button)	.....	71
Recirculation mode (automatic climate control system)	.....	71
Recuperation	.....	16
Refueling	.....	311
Remote control		
<i>refer to</i> Remote control key	.....	31
Remote control key	.....	31
Remote control operation		
Garage door opener (HomeLink)	.....	43
Remote locking and unlocking		
Audi connect vehicle control	.....	198
Removing the caps (wheel bolts)	.....	353
Repair manuals	.....	371
Repairs		
Airbag system	.....	284
Replacement key	.....	31
Replacing		
Light bulbs	.....	362
Replacing wiper blades	.....	53
Reporting Safety Defects	.....	259
Reset		
<i>refer to</i> Restart (MMI)	.....	250
Reset button (trip odometer)	.....	12
Resetting the trip odometer	.....	12
Residual heat (automatic climate control)	..	72
Restart (MMI)	.....	250
Retractor	.....	264
Reverse gear	.....	85
Rewinding (audio/video file)	.....	234
Right control button	.....	13
Rims	.....	340
Cleaning	.....	345
Ringtone settings	.....	185
Road carrier	.....	368
Roaming		
<i>refer to</i> Data connection	.....	194
Roof load	.....	67, 370
Roof rack	.....	67
<i>also refer to</i> Roof rack	.....	67
Route criteria	.....	212
Route guidance		
<i>refer to</i> Navigation	.....	203
Running direction (tires)	.....	355
<b>S</b>		
Safe driving habits	.....	252
Safety		
Airbag system	.....	269
Belts	.....	261
Cargo	.....	257
Correct seating position	.....	253
Pedal area	.....	256
Telephone	.....	174
Safety belt height adjustment	.....	266
Safety belt position	.....	265
Safety belt height adjustment	.....	266
Safety belts worn by pregnant women	...	266
Safety belt pretensioner		
Service and disposal	.....	268
Safety belts	.....	261, 264
Cleaning	.....	346
Danger to passengers who do not wear a safety belt	.....	262
Fastening	.....	264
Improperly worn	.....	267
Not worn	.....	262
Safety belt position	.....	265
Safety instructions	.....	263
Securing child safety seats	.....	302
Special considerations for pregnant women	.....	266
Unfastening	.....	266
Warning/indicator light	.....	261
Worn properly	.....	263
Safety belt warning light	.....	261
Safety instructions		
for side curtain airbags	.....	290
for using child safety seats	.....	295
for using safety belts	.....	263
Monitoring the Advanced Airbag System	..	283

- 
- Saving fuel
    - Energy consumers ..... 17
    - Recuperation ..... 16
  - Scan (radio) ..... 221
  - Screen
    - refer to* Display ..... 12, 15
  - Screwdriver ..... 350
  - SD card reader (MMI) ..... 226
  - SDS
    - refer to* Speech dialog system ..... 166
  - Search area (point of interest) ..... 206
  - Search function
    - refer to* Free text search ..... 157, 236
  - Seat adjustment
    - Head restraints ..... 255
  - Seat belts
    - refer to* Safety belts ..... 261
  - Seat heating/ventilation ..... 71
  - Seating capacity ..... 261
  - Seating position
    - Driver ..... 253
    - Front passenger ..... 254
    - How to adjust the front seats ..... 254
    - Incorrect seat position ..... 256
    - Occupants ..... 253
    - Rear passengers ..... 254
  - Seats
    - Adjusting ..... 56
    - Adjusting the rear seats ..... 57
    - Cleaning ..... 347
    - Correct seating position ..... 253
    - Number of seats ..... 261
  - Secondary phone ..... 176, 247
  - Selecting a source (media) ..... 234
  - Selection menu ..... 13, 150, 154
  - Selective wheel torque control ..... 140
  - Selector lever
    - Selector lever positions ..... 85
  - Self-learning navigation
    - refer to* Personal route assistance ..... 209
  - Service and disposal
    - Safety belt pretensioner ..... 268
  - Service interval display ..... 324
  - Service position
    - refer to* Replacing wiper blades ..... 53
  - SET REAR (button) ..... 72
  - Settings
    - Directory ..... 185
    - Map ..... 214
    - Media ..... 237
    - Navigation ..... 211
    - Radio ..... 223
    - System (MMI) ..... 245
    - Telephone ..... 184
    - Voice recognition system ..... 245
  - Setting the language ..... 245
  - Shade
    - Rear window/rear doors ..... 51
  - Shift paddles ..... 88
  - Ship carrier ..... 368
  - Shortcut keys ..... 147, 155
  - Shuffle ..... 237
  - Side airbags ..... 285
    - How they work ..... 287
  - Side assist
    - Cleaning the sensors ..... 345
    - also refer to* Audi side assist ..... 120
  - Side curtain airbags ..... 288
    - Description ..... 288
    - How they work ..... 289
    - Safety instructions ..... 290
  - SiriusXM alert notifications ..... 222
  - Snow chains ..... 340
  - Socket
    - refer to* Power sources ..... 60
  - Software update
    - refer to* Map update ..... 191
    - refer to* System update (MMI) ..... 248
  - Software (MMI)
    - Licensing agreements ..... 250
    - Update ..... 248
    - Version ..... 248
  - Sources of information about child restraints and their use ..... 309
  - Speech dialog system
    - Multifunction steering wheel ..... 14
    - Volume ..... 14
  - Speed dependent volume control ..... 249
  - Speed limit info
    - refer to* Traffic sign recognition ..... 97
  - Speed limits
    - refer to* Traffic sign recognition ..... 97
  - Speedometer ..... 10

Speed warning system . . . . .	95	System settings (MMI) . . . . .	245
Speller . . . . .	155	System update (MMI) . . . . .	248
Sport differential . . . . .	125	System volume . . . . .	250
Indicator light . . . . .	28		
Sport view . . . . .	14	<b>T</b>	
Stabilization program		Tachometer . . . . .	10, 11
<i>refer to</i> ESC . . . . .	140, 141	Tail lights	
Start/Stop system . . . . .	78	Cleaning . . . . .	345
Messages . . . . .	80	Technical data . . . . .	369
Switching off/on . . . . .	80	Technical modifications . . . . .	374
START ENGINE STOP button . . . . .	76	Telephone . . . . .	174
Starting to drive . . . . .	82	Connecting . . . . .	174
Starting (engine) . . . . .	76, 77, 79	Dialing a number . . . . .	177
Steering		Options during a phone call . . . . .	178
Electromechanical steering . . . . .	144	Playing music . . . . .	228
<i>also refer to</i> Electromechanical steering . . . . .	144	Settings . . . . .	184
Steering wheel		Temperature display	
Easy seat entry . . . . .	76	Coolant . . . . .	10
Manual adjustment . . . . .	75	Outside temperature . . . . .	10
Power adjustment . . . . .	76	Tether anchors . . . . .	308
Shift paddles . . . . .	88	Tether strap . . . . .	308
Steering wheel heating . . . . .	72	Text messages . . . . .	180
<i>also refer to</i> Multifunction		<i>also refer to</i> Text messages . . . . .	180
steering wheel . . . . .	12, 14, 15	Tie-downs . . . . .	65, 258
Steps for determining correct load limit . . . . .	339	Tightening specification	
Stopover (navigation) . . . . .	208	Wheel bolts . . . . .	356
Stopping (engine) . . . . .	79	Tightening specification (wheel bolts) . . . . .	356
Storage compartments . . . . .	61	Tilt angle display . . . . .	84
Streaming		Time . . . . .	245
<i>refer to</i> Online media . . . . .	230	Tire Mobility System (tire repair set) . . . . .	350
S tronic (automatic transmission) . . . . .	84	Tires . . . . .	325
Subtitles (DVD) . . . . .	237	Low-profile tires . . . . .	341
Subwoofer . . . . .	249	quattro . . . . .	144
Sunshade		Repair set . . . . .	350
Rear window/rear doors . . . . .	51	Replacing . . . . .	352
Sun visors . . . . .	51	Service life . . . . .	334
Swap call . . . . .	178	Tire pressure . . . . .	335
Switching tabs		Tire pressure monitoring system . . . . .	342
<i>refer to</i> Multifunction		Tire pressure table . . . . .	336
steering wheel . . . . .	12, 14, 15	Tire pressure (trailer towing) . . . . .	92
Switching the ignition on/off . . . . .	76	Treadwear indicators . . . . .	334
Symbols . . . . .	158	Unidirectional . . . . .	327, 355
Navigation . . . . .	213	Uniform tire quality grading . . . . .	341
Traffic . . . . .	217, 218	Tires and wheels	
<i>also refer to</i> Indicator lights . . . . .	19	Glossary of tire and loading terminology . . . . .	328
SYNC (button) . . . . .	72	Tires and vehicle load limits . . . . .	337

- TMC  
*refer to* Traffic information ..... 218
- Tone (sound)  
*refer to* Adjusting the sound ..... 249
- Tool ..... 350
- Torn or frayed safety belts ..... 263
- Touch  
*refer to* MMI touch ..... 151
- Towing  
 Tow trucks ..... 365
- Towing loop ..... 365, 366
- Towing protection monitoring ..... 36
- TPMS  
 Tire pressure monitoring system ..... 342
- Traffic information ..... 217, 218, 219
- Traffic jam assist ..... 109
- Traffic messages ..... 214
- Traffic sign recognition ..... 97
- Trailer load ..... 370
- Trailer mode (navigation) ..... 211
- Trailer towing ..... 92  
 Parking systems ..... 139  
 Trailer load ..... 92  
 Turn signals ..... 29
- Transport Canada ..... 259
- Travel guide  
*refer to* Travel (travel guide) ..... 191
- Travel (travel guide) ..... 191
- Treble (sound) ..... 249
- Trip computer ..... 16
- Turn assist ..... 113
- Turn signal ..... 46
- U**
- Unfastening safety belts ..... 266
- Uniform tire quality grading ..... 341
- Unlocking/locking  
 By remote control ..... 33  
 With the central locking switch ..... 34  
 With the convenience key ..... 33  
 With the lock cylinder ..... 35
- Updating stations (radio) ..... 220
- USB charging port ..... 60, 232, 233
- USB stick  
*refer to* Audi music interface ..... 231, 232
- V**
- Vanity mirror ..... 51
- Vehicle  
 Care/cleaning ..... 344  
 Dimensions ..... 369  
 Out of service ..... 349  
 Raising ..... 354  
 Specifications ..... 369  
 Transporting ..... 368
- Vehicle battery ..... 321  
 Charge level ..... 145  
 Charging ..... 323  
 Winter operation ..... 322
- Vehicle care ..... 344
- Vehicle control modules ..... 145
- Vehicle jack ..... 350  
 Lifting points ..... 354  
 Wheel change mode ..... 352
- Vehicle key ..... 31
- Vehicle status report  
 Audi connect vehicle control ..... 198
- Vehicle tool kit ..... 350
- Ventilation ..... 69
- Version information ..... 248
- VIEW button ..... 12
- VIN ..... 369
- Voice guidance  
*refer to* Multifunction  
 steering wheel ..... 12, 14, 15
- Voicemail ..... 182
- Voice recognition system ..... 167  
 Commands ..... 168  
 External ..... 172  
 Operating ..... 167  
 Settings ..... 245  
 Volume ..... 250
- Volume ..... 249
- W**
- Warning lights  
*refer to* Indicator lights ..... 19
- Warranty coverages ..... 371
- Washing matte finish paint ..... 344
- Web radio ..... 230
- Weights ..... 370

- What happens if you wear your safety belt too loose? ..... 265
- What happens to unbelted occupants? .... 262
- What impairs driving safety? ..... 252
- Wheel bolts ..... 340
- Wheel replacement ..... 352
- Wheels ..... 325
- Cleaning ..... 345
- Glossary of tire and loading terminology . 328
- Replacing ..... 352
- Tire pressure monitoring system ..... 342
- Tires and vehicle load limits ..... 337
- Wheel wrench ..... 350
- When must a safety belt be replaced? .... 263
- When must the airbag system be inspected? 281
- Where are lower anchorages located? .... 306
- Wi-Fi
- Audi music stream ..... 229
- Audio player ..... 229
- Online media ..... 230
- also refer to* Wi-Fi ..... 229
- Windows
- Child safety lock ..... 40
- Cleaning/removing ice ..... 346
- Defrosting ..... 71
- Power windows ..... 40
- Windshield
- Cleaning ..... 51
- Defrosting ..... 71
- also refer to* Windshield ..... 51
- Windshield washer system ..... 51, 323
- Reservoir capacity ..... 369
- Windshield wipers ..... 51
- Winter operation
- Car washes ..... 344
- Cooling system ..... 319
- Defrosting the windows ..... 71
- Removing ice from windows ..... 346
- Seat heating ..... 71
- Snow chains ..... 340
- Steering wheel heating ..... 72
- Tires ..... 340
- Vehicle battery ..... 322
- Windshield washer system ..... 323
- Winter tires ..... 340
- X**
- Xenon headlights ..... 362
- Z**
- Zooming on the map
- Multifunction steering wheel ..... 13
- Zoom (map) ..... 205, 213

It has always been Audi's policy to continuously improve its products. AUDI AG reserves the right to make changes in design and specifications, and to make additions or improvements in its products without incurring any obligation to install them on products previously manufactured. This Owner's Manual is based on the current data available when it was printed. Text, illustrations and specifications in this owner's manual are based on the most up-to-date information available at the time of printing, and shall not constitute a basis for liability claims.

These instructions may not be reproduced or translated in whole or in part without written consent of AUDI AG. All rights reserved by AUDI AG.



**For the sake of the environment**

Printed on eco-friendly paper (bleached without chlorine, recyclable).

**Owner's Manual**  
**Englisch Nordamerika 05.2017**  
**80A012721BC**



80A012721BC

[www.audi.com](http://www.audi.com)