

Owner's Manual

Atlas

Edition 2024/09

United States version

Teil-Nr.: 3CN012723SP

Print status: 24.05.2024

English USA: 2024.09

V1, R1, USA, en_US

Vehicle-specific information can be entered below:

Vehicle Identification Number (VIN)																

Vehicle information	
Engine output (kW)	
Engine code	
Transmission code	
Paint number	
Recommended engine oil	

PR number	Vehicle service type

Notes

Delivery inspection was performed on: Volkswagen dealer stamp	Date of delivery/first approval (whichever occurs first): Volkswagen dealer stamp
---	---



WARNING

Operating, servicing and maintaining a passenger vehicle or off-highway motor vehicle can expose you to chemicals including engine exhaust, carbon monoxide, phthalates, and lead, which are known to the State of California to cause cancer and birth defects or other reproductive harm. To minimize exposure, avoid breathing exhaust, do not idle the engine except as necessary, service your vehicle in a well-ventilated area and wear gloves or wash your hands frequently when servicing your vehicle. For more information go to www.P65Warnings.ca.gov/passenger-vehicle.

BTT-1671

Fig. 1

Volkswagen AG works constantly to improve all of its products. Due to ongoing vehicle development, changes in design, equipment, and technology are possible at any time. The information regarding equipment, appearance, performance, dimensions, weights, standards, and functions of the vehicle is the information that was available at the time of the editorial deadline for this manual. Some of the equipment and functions may not be available until later or may be available only in certain countries. Contact your local authorized Volkswagen dealer or authorized Volkswagen Service Facility for more information.

The vehicle shown may be equipped with optional equipment for an additional price and is only offered in certain markets. An authorized Volkswagen dealer can inform you about differences in your particular country. Subject to change. No legal obligations or commitments may be derived from the information, illustrations, and descriptions in this manual.

No reprint, reproduction, or translation of this Manual is permitted, even in excerpts, without the express written consent of Volkswagen AG.

Volkswagen AG expressly reserves all rights under applicable copyright law. Subject to change.

© 2024 Volkswagen AG

We thank you for buying a Volkswagen vehicle

This Volkswagen vehicle is equipped with advanced technology incorporating a number of convenience features for you to enjoy in your daily driving.

Please carefully read and follow the information in this Owner's Manual. It will help you to become more familiar with your vehicle and to be able to recognize and avoid hazardous situations for you and others.

If you have questions about your vehicle or if you believe that the manual is not complete, please contact your authorized Volkswagen dealer or your authorized Volkswagen Service Facility. Authorized Volkswagen dealers and authorized Volkswagen Service Facilities always welcome your questions, suggestions, and constructive criticism.

We hope you enjoy driving your vehicle and we wish you safe and pleasant motoring.

WARNING

Follow the important safety instructions about using child restraint systems in the front passenger seat →  [Introduction](#)

About this Owner's Manual

This Owner's Manual is valid for all models and versions of your Volkswagen model and model year. The Owner's Manual describes all equipment and models without indicating special equipment or model versions. This may include descriptions of equipment that your vehicle may not have or that may only be available in some countries.

You can find details of your actual vehicle equipment in your sales documentation or by contacting an authorized Volkswagen dealer or authorized Volkswagen Service Facility. Volkswagen recommends contacting an authorized Volkswagen dealer or authorized Volkswagen Service Facility.

This Owner's Manual describes a passenger vehicle.

All information in this Owner's Manual was correct at the time of printing. Due to continuous vehicle development, there may be differences between your vehicle and the information in this Owner's Manual. No legal commitment can be derived from the information, illustrations, or descriptions in this manual.

Due to legal and technical requirements, the vehicle may be provided with different Owner's Manual variants depending on the country.

Printed Owner's Manual

The printed Owner's Manual describes the range of functions of the vehicle at the time of release. Additions and amendments to the Owner's Manual may also be added in the form of supplements.

An alphabetically ordered keyword index as well as a list of abbreviations that explains technical abbreviations and designations are included to assist with orientation and understanding of the printed manual.

 Make sure that the printed documents are in the vehicle if you wish to sell or lend the car. Volkswagen also recommends resetting the Infotainment system to its factory settings in order to delete all personal data.

Explanations

Brief definitions are placed in front of some sections in a different color to summarize the topic in question. Detailed information about the systems and equipment along with their properties, conditions, and system limitations is included in the associated sections.

The following section explains phrasings and terms found in the Owner's Manual to help understanding.

Directions

Directions (left, right, front, back) are in reference to the driving direction unless noted otherwise.

Units and speeds

The display in miles instead of kilometers or mph instead of km/h is determined by the versions of the instrument cluster and Infotainment system that are installed, which varies depending on the country where the vehicle is sold.

Illustrations

Illustrations are only for orientation and are simply used to provide a visual display of descriptions and instructions. The illustrations may differ from your vehicle.

This Owner's Manual was created for left-hand drive vehicles. For *vehicles with right-hand drive steering*, controls are sometimes arranged differently from what is shown in the illustrations or described in the text.

Form of address

To improve readability, plural pronouns are used here to refer to a singular subject of any gender. This applies to all genders equally. The use of abbreviations are for editorial purposes and do not contain any evaluation.

Terms used and their meanings:

Sunroof The term "sunroof" is used as a synonym for all equipment-dependent versions of the sliding, tilting, or tilting and sliding panoramic sunroof









Authorized Volkswagen dealer or authorized Volkswagen Service Facility Authorized Volkswagen dealer or authorized Volkswagen Service Facility refers to workshops with instructed or trained personnel that specialize in servicing passenger vehicles. A qualified professional can be an authorized Volkswagen dealer or authorized Volkswagen Service Facility or an independent workshop.

Authorized Volkswagen dealer or authorized Volkswagen Service Facility Authorized Volkswagen dealer or authorized Volkswagen Service Facility refers to workshops that have a contractual relationship with Volkswagen. This contractual relationship means that they have access to more information as well as a direct line of communication to the manufacturer.

Contact an authorized Volkswagen dealer or authorized Volkswagen Service Facility In some situations, it is necessary for you to drive your vehicle to an authorized Volkswagen dealer or authorized Volkswagen Service Facility so that it can be checked.

Contact an authorized Volkswagen dealer or authorized Volkswagen Service Facility for assistance If it is no longer possible to continue driving your vehicle, it is necessary to have it checked directly where it is by a professional. A decision regarding whether the vehicle can continue to be driven following inspection or whether it needs to be towed must then be made depending on the circumstances.

Explanation of symbols

	Indicates a reference to a section within a chapter containing important information and safety warnings  that should always be heeded.
	The arrow indicates the end of a section.
	This symbol indicates situations where the vehicle must be stopped as quickly as possible.
TM	The symbol means “Trademark” and indicates a recognized but not (yet) officially registered trademark. However, the absence of this symbol does not constitute a waiver of any rights associated with intellectual property.
	This symbol indicates a registered trademark. However, the absence of this symbol does not constitute a waiver of any rights associated with intellectual property.
	Symbols of this type refer to warnings in the same section or on the specified page, pointing out possible risks that can cause accidents and personal injuries and how to help prevent them.
	
	
	
	Cross-reference to a warning of potential property damage, in the same section or on the specified page.

DANGER

DANGER indicates a hazardous situation which, if not avoided, will result in death or serious injury.

WARNING

WARNING indicates a hazardous situation which, if not avoided, could result in death or serious injury.

CAUTION

CAUTION indicates a hazardous situation which, if not avoided, could result in minor or moderate injury.

NOTICE

NOTICE is used to address practices not related to physical injury, but related to damage to the vehicle.

 Texts with this symbol contain information about the environment and how you can help to protect it.

 Texts with this symbol contain supplementary information.

Vehicle overviews

View from the front

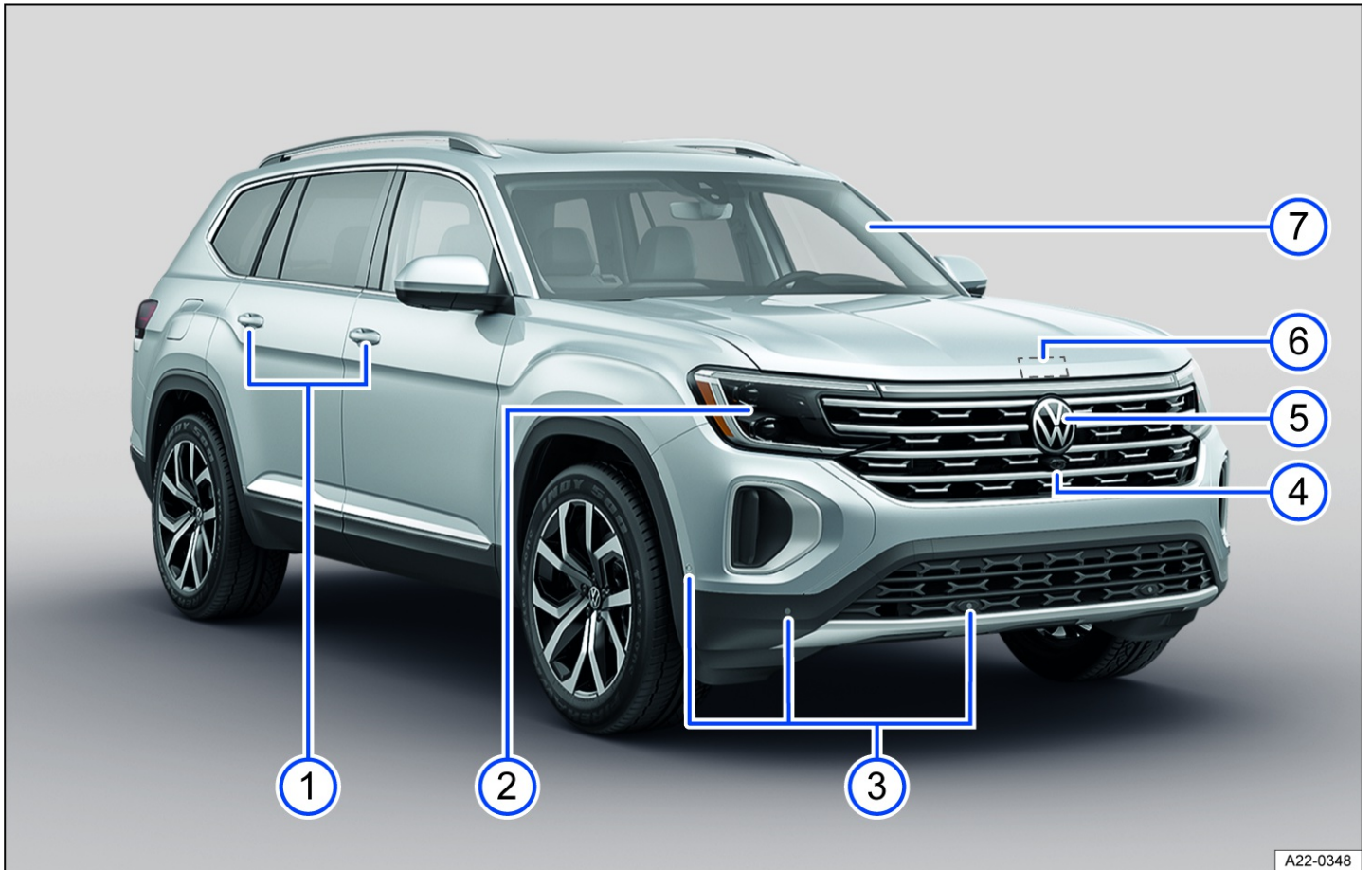
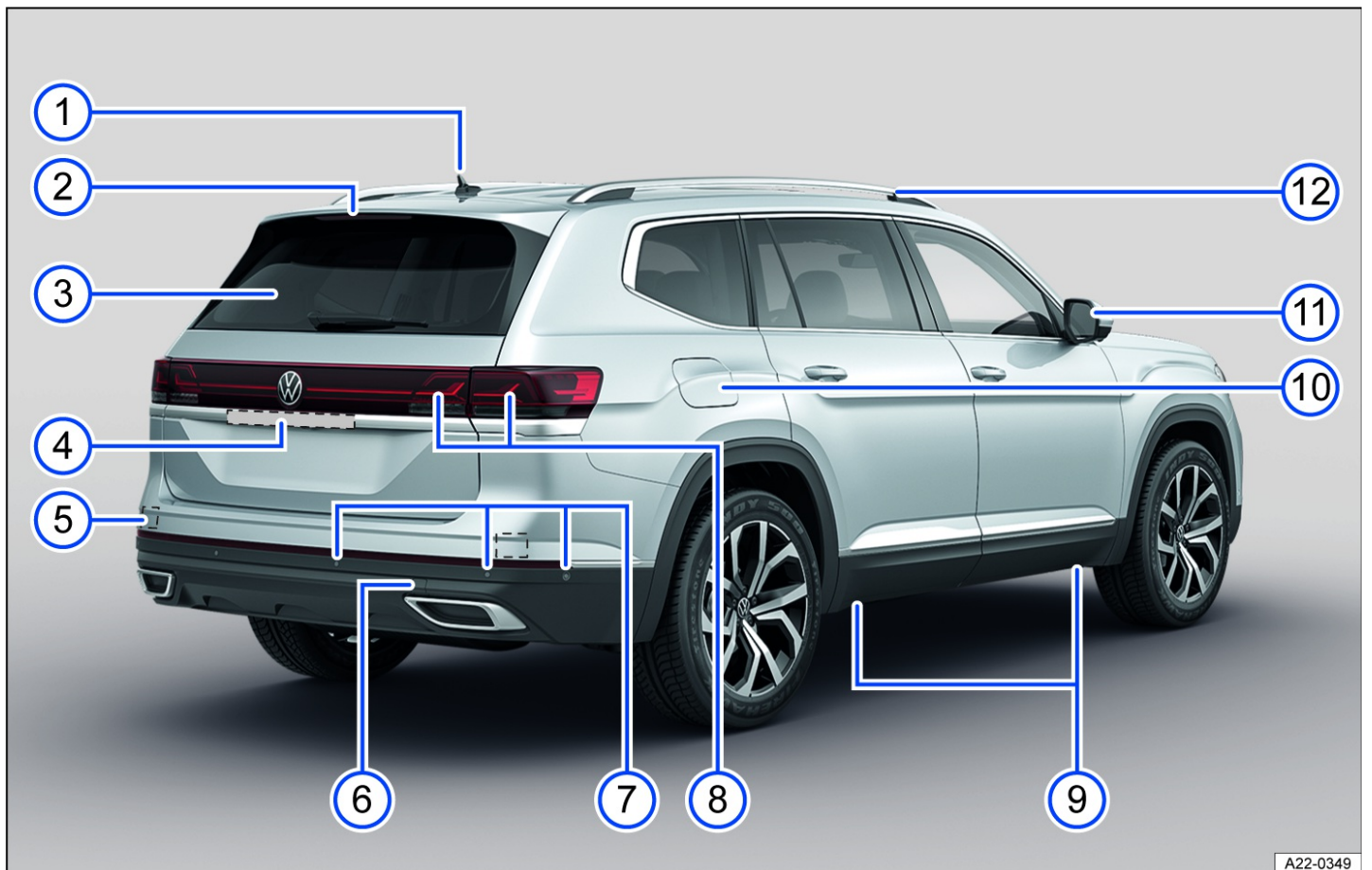

Fig. 2 Overview of vehicle from the front.

- ① Door handles ⇒ *Doors and central locking*
- ② Headlights ⇒ *Exterior lighting*
- ③ Sensors for assistance systems ⇒ *Sensor system information, ⇒ Exterior care and cleaning*
- ④ Camera for Area View ⇒ *Area View, ⇒ Exterior care and cleaning*
- ⑤ Behind the Volkswagen emblem: radar sensor for assistance systems ⇒ *Sensor system information, ⇒ Exterior care and cleaning*
- ⑥ Opening lever for the hood ⇒ *Opening and closing the hood*
- ⑦ Windshield
 - With VIN ⇒ *Technical data*
 - With windshield wipers ⇒ *Operating the windshield wiper lever*
 - With camera for assistance systems in the interior rearview mirror area ⇒ *Sensor system information, ⇒ Exterior care and cleaning*
 - With rain/light sensor in the interior rearview mirror area ⇒ *Rain/light sensor, ⇒ Exterior care and cleaning*

Rear view



A22-0349

Fig. 3 Rear vehicle overview.

- ① Roof antenna ⇒ *Infotainment system and aerials*
- ② High-mounted brake light
- ③ Rear window
 - With rear window defroster ⇒ *Rear window defroster*
 - With rear window wiper ⇒ *Operating the windshield wiper lever*
 - With window antenna ⇒ *Infotainment system and aerials*
- ④ Area
 - Button to open the trunk lid ⇒ *Trunk lid*
 - Camera for parking systems ⇒ *Rear View Camera*, ⇒ *Exterior care and cleaning*
 - License plate light ⇒ *Exterior lighting*
- ⑤ Behind the bumper: radar sensor for assistance systems ⇒ *Sensor system information*, ⇒ *Exterior care and cleaning*
- ⑥ Behind a cover: mount for towing eye ⇒ *Transporting the Vehicle Away and Towing*
- ⑦ Sensors for assistance systems ⇒ *Sensor system information*, ⇒ *Exterior care and cleaning*
- ⑧ Taillights ⇒ *Exterior lighting*
- ⑨ Mounting points for the vehicle jack ⇒ *Wheel change*
- ⑩ Fuel filler flap ⇒ *Fuel types and refueling*
- ⑪ Outside mirrors ⇒ *Outside mirrors*
 - With camera for Area View ⇒ *Area View*, ⇒ *Exterior care and cleaning*

Driver side

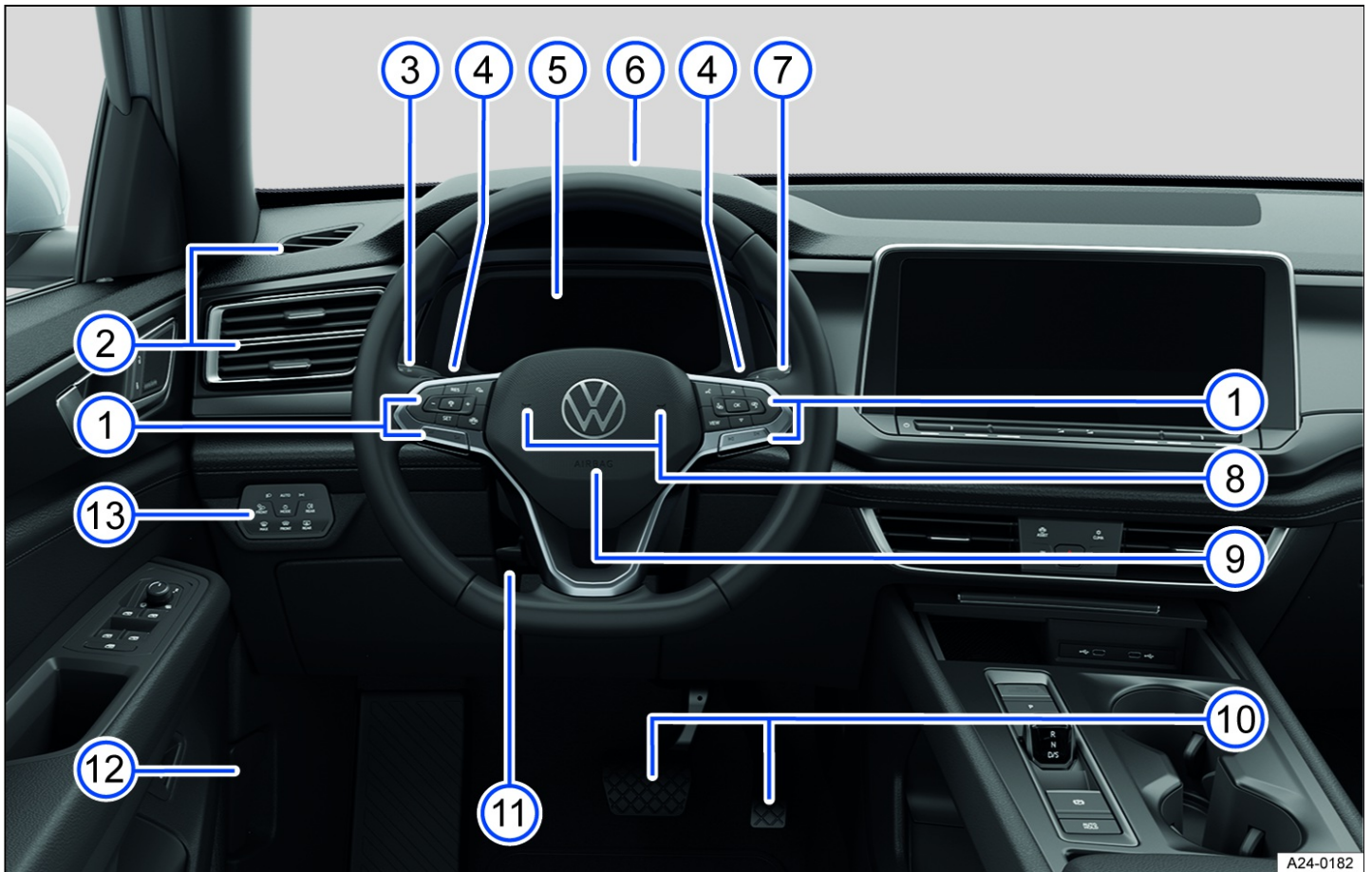







Fig. 4 Driver's side overview.

1 Multi-function steering wheel controls:

- For driver assistance systems ⇒ *Driver assistance systems*
- For menu selection ⇒ *Operating the Digital Instrument Cluster*
- For steering wheel heating  ⇒ *Steering wheel heating*
- For accepting telephone calls **OK**
- For audio, navigation  , ⇒ *Infotainment system*, ⇒ *Navigation*
- For adjusting the volume  
- For voice operation activation  (may not function depending on the equipment) ⇒ *Voice control*
- In order to switch between the current and previous menus **VIEW** ⇒ *Operating the Digital Instrument Cluster*

2 Vents ⇒ *Air distribution and blower speed*



3 Turn signal and high beam lever ⇒ *Switching the turn signals on and off, ⇒ Switching the high beam headlights on and off*

- With switch and buttons for driver assistance systems ⇒ *Driver assistance systems*

4 Shift paddle for Tiptronic ⇒ *Shifting using tiptronic*

5 Instrument cluster ⇒ *Volkswagen Digital Cockpit overview*

- With warning and indicator lights ⇒ *Symbols in the instrument cluster*

- ⑥ Head-up display ⇒ *Head-up display*
- ⑦ Windshield wiper/washer lever ⇒ *Window wipers*
- ⑧ Horn 
- ⑨ Installation location of driver's front airbag ⇒ *Airbag system*
- ⑩ Pedals ⇒ *Information on the pedals*
- ⑪ Lever for adjusting the steering wheel position ⇒ *Steering wheel*
- ⑫ Hood release lever  ⇒ *Opening and closing the hood*
- ⑬ Control panel:

- For light functions ⇒ *Exterior lighting*
- For window heating and ventilation ⇒ *Rear window defroster*, ⇒ *Air distribution and blower speed*

Driver door

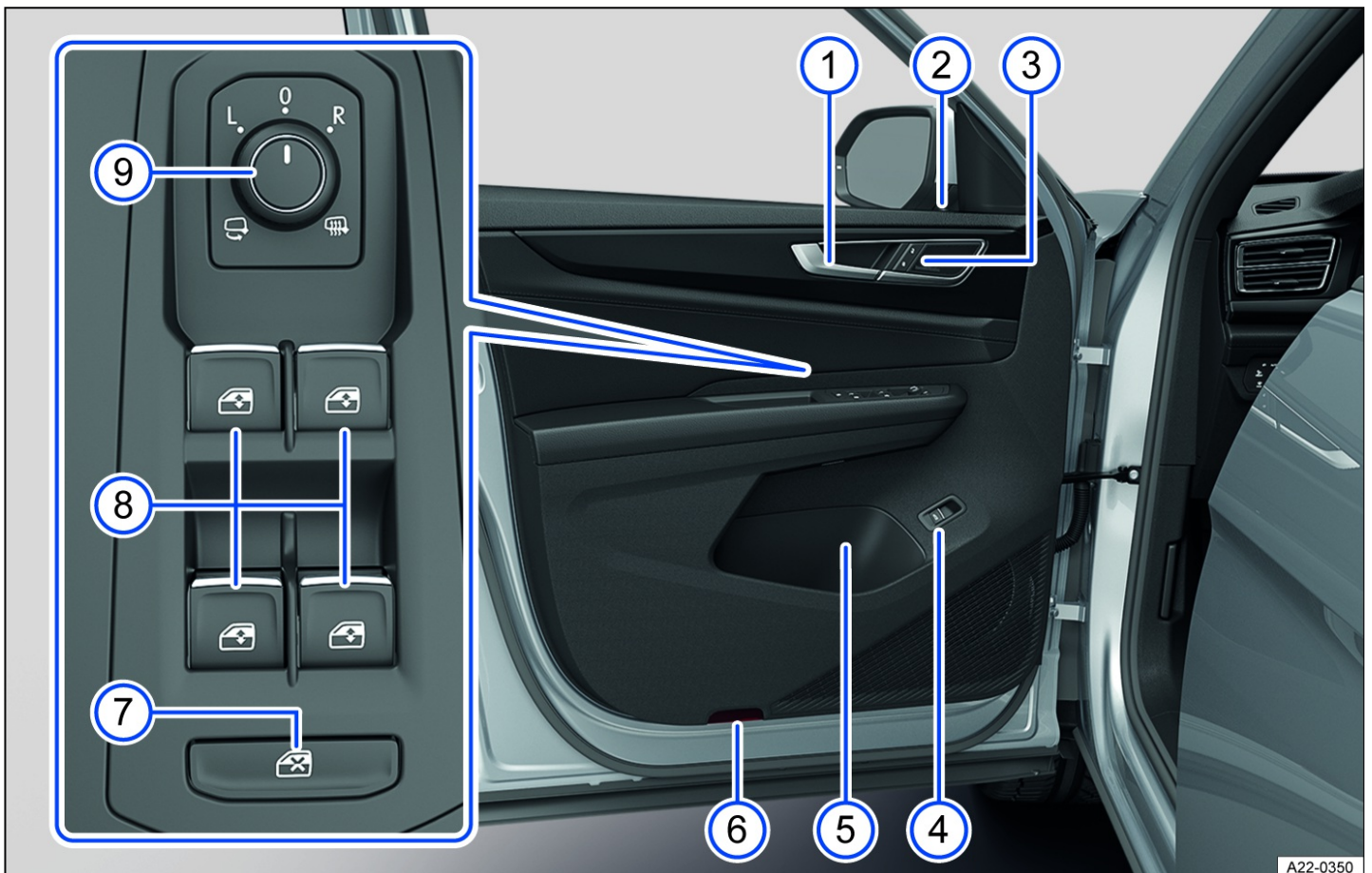





Fig. 5 Driver door: Controls.

- ① Door handle
- ② Central locking indicator light ⇒ *Indicator light in the driver's door*
- ③ Central locking button to lock and unlock the vehicle ⇒ *Central locking button*
- ④ Button for unlocking the trunk lid  ⇒ *Trunk lid*
- ⑤ Storage compartment with cup holder
- ⑥ Door lights or reflectors

- ⑦ Button for deactivating the power window buttons in the rear doors  ⇒ *Opening and closing the windows*
- ⑧ Buttons for operating the power windows  ⇒ *Opening and closing the windows*
- ⑨ Knob for outside mirror positions and functions ⇒ *Outside mirrors*

Center console

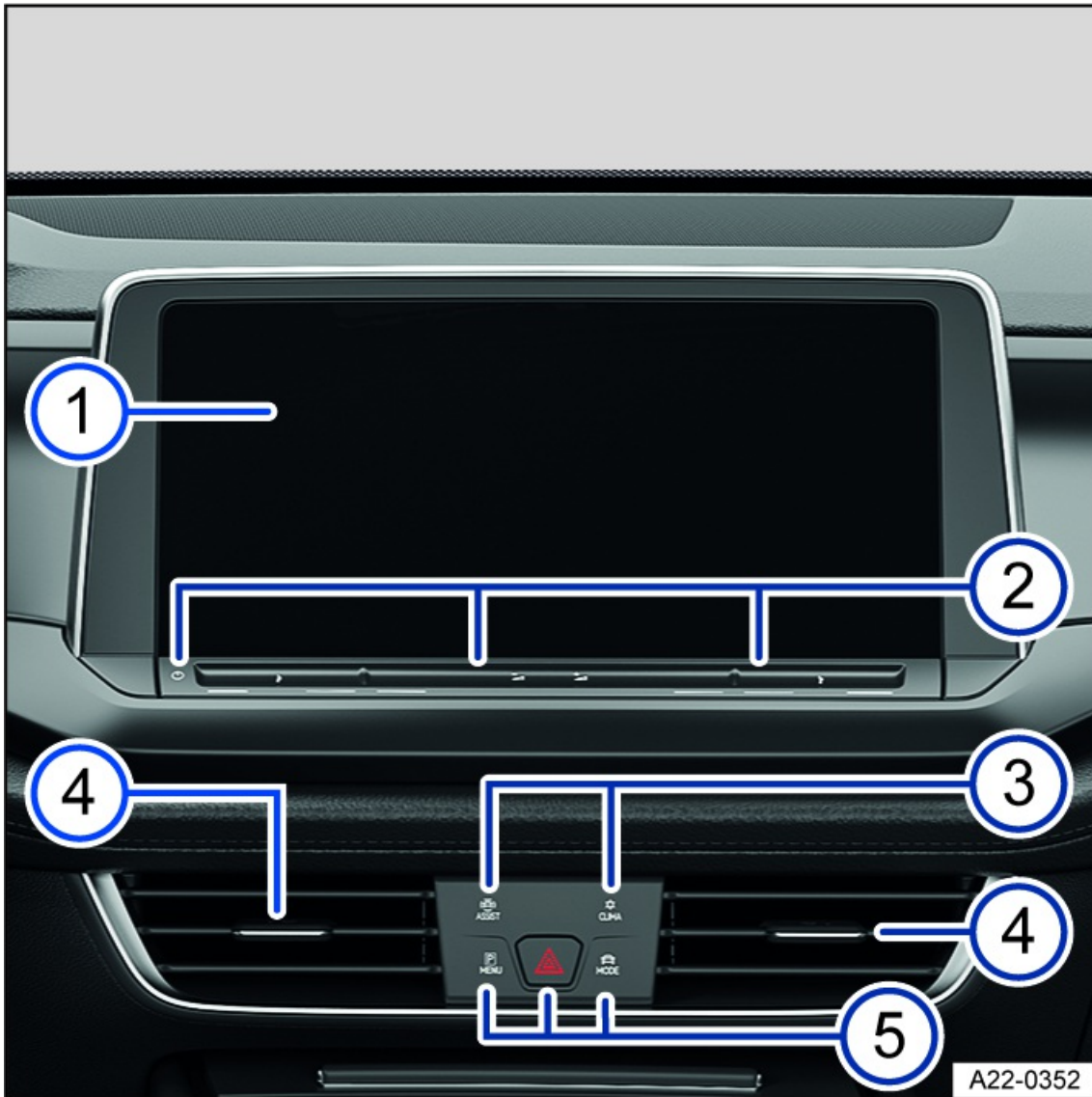

Fig. 6 Overview of the upper section of the center console.

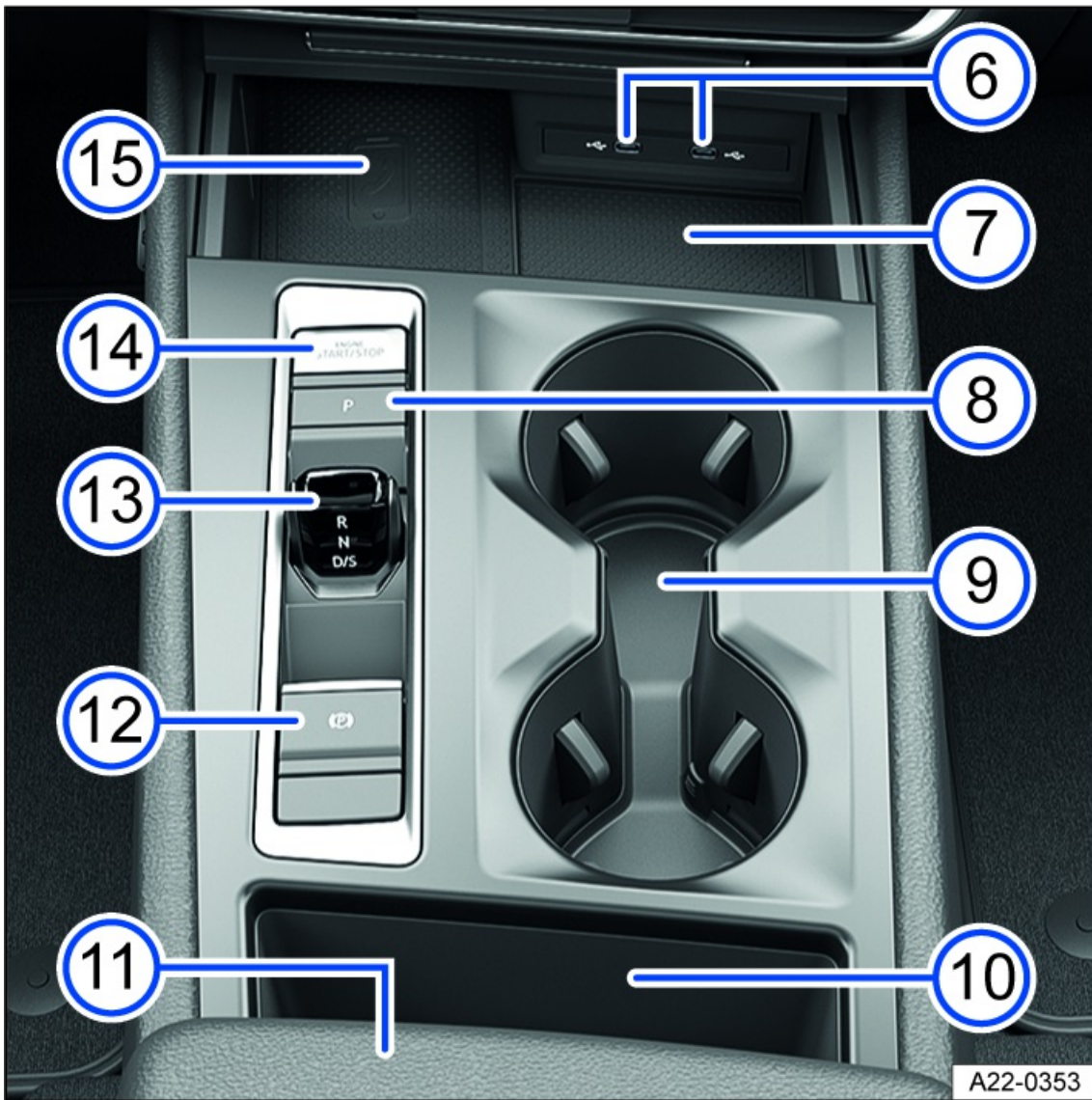





Fig. 7 Overview of the lower section of the center console.

① Infotainment system ⇒ *First steps*

② Controls



- For switching the Infotainment system on and off  ⇒ *Overview of Infotainment system*
- For the temperature setting of the air conditioner or the heating and fresh air system ⇒ *Heating and air conditioning system*
- For adjusting the volume 

③ Controls

- For driver assistance systems  ⇒ *Driver assistance systems*
- For the air conditioning system, heating and fresh air system  ⇒ *Heating and air conditioning system*

④ Vents ⇒ *Air distribution and blower speed*

⑤ Controls:

- For parking and maneuvering assist systems  ⇒ *Parking and maneuvering*
- Button for switching the emergency flashers on or off  ⇒ *In case of an emergency*
- for Driving Mode Selection  ⇒ *4MOTION Active Control*

- ⑥ USB sockets with charge function for external device rechargeable batteries (depending on the vehicle equipment)
⇒ *Wired and wireless connections*, ⇒ *Charging Options for Mobile Devices*
- ⑦ Storage compartment
- ⑧ Parking lock P ⇒ *Selector lever*
- ⑨ Cup holders
- ⑩ Storage compartment
- ⑪ Center armrest
- ⑫ Electronic parking brake (Ⓔ) ⇒ *Electronic parking brake*
- ⑬ Selector lever of the automatic transmission ⇒ *Automatic transmission*
- ⑭ Button to start and stop the engine (Keyless Access with push-button start) ⇒ *Starter button*
- ⑮ Storage compartment
 - With functionality for wireless charging in accordance with Qi standard ⇒ *Charging Options for Mobile Devices*
 - with phone interface ⇒ *Mobile phone interface*

Passenger's side

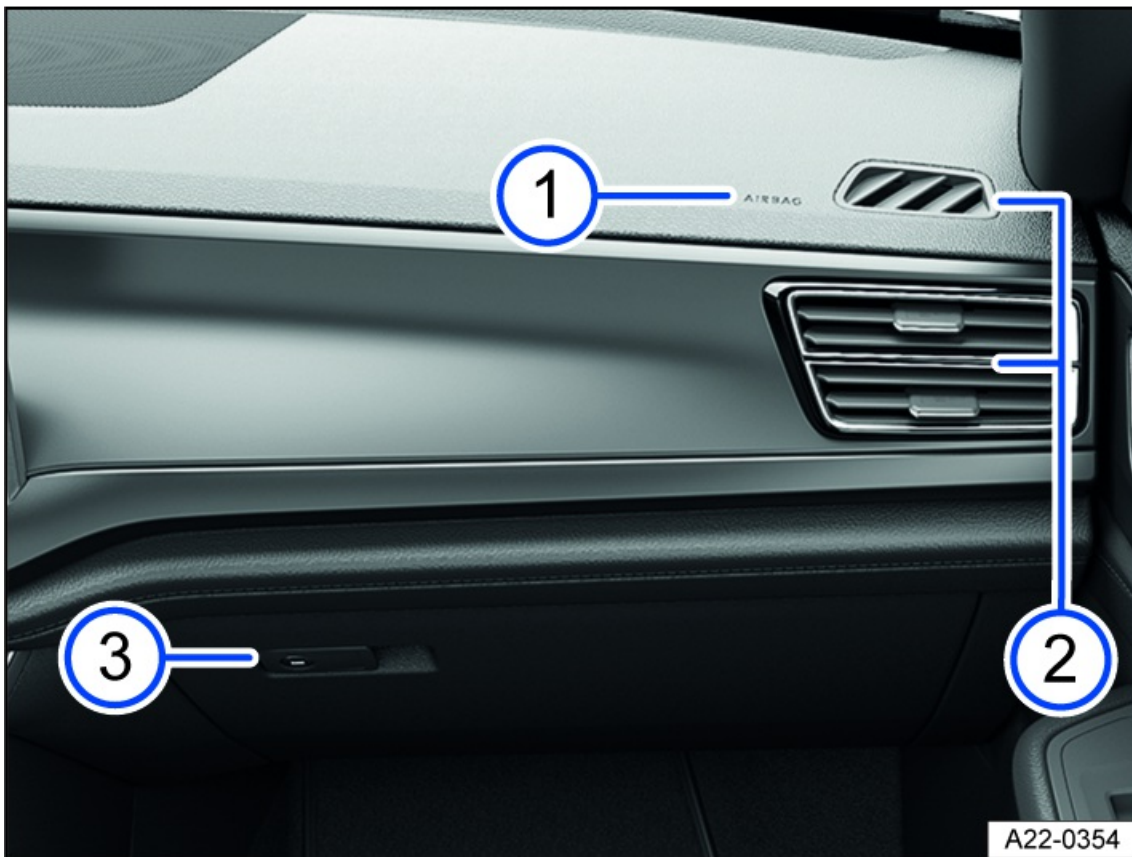









Fig. 8 Passenger's side: instrument panel overview

- ① Installation location of the front passenger's airbag in the instrument panel ⇒ *Airbag system*
- ② Vents ⇒ *Air distribution and blower speed*
- ③ Glove compartment with handle

Controls and Displays in the Roof Console

 Control for interior light ⇒ *Interior/reading lights, ambient lighting*.  Control for reading light ⇒ *Interior/reading lights, ambient lighting*.  Control for tilting and sliding panoramic sunroof ⇒ *Sunroof*.  Control panel for controlling the headliner ⇒ *Sunshade in the sunroof*.  Buttons for Information Call, Roadside Call Assist and Emergency Call ⇒ *Information Call, Roadside Assistance Call and Emergency Call Service*. **ON**  Indicator light for activated front passenger's front airbag ⇒ *Airbag system*. **OFF**  Indicator light for deactivated front passenger's front airbag ⇒ *Airbag system*.

Driver information

Symbols in the instrument cluster

The warning and indicator lights can turn on individually or in combination with each other and indicate warnings, malfunctions and certain functions. Some warning and indicator lights come on when you switch the ignition on and must turn off after some time.









Information on other indicator lights, e.g. in switches or on control panels, can be found in the corresponding chapters.



















WARNING









Failure to respond to illuminated warning lights and messages may result in a vehicle breakdown, accidents and serious injuries or death.

















- Never ignore illuminated warning lights and messages.
- Stop the vehicle as soon as it is safe to do so.















 Due to continuous vehicle development, the warning and indicator lights listed here may differ from those in the vehicle after an update.

















	 Do not continue driving! Central warning light ⇒ <i>Priority 1 warning message</i>
	Fastening the safety belt ⇒ <i>Fasten seat belts reminder</i>
PARK	Electronic parking brake is switched on ⇒ <i>Electronic parking brake</i>
	Electronic parking brake holding force is too low ⇒ <i>Electronic parking brake</i>
BRAKE	 Do not continue driving! Brake system malfunction ⇒ <i>Brake system malfunction, ⇒ Electronic parking brake malfunction</i>
	 Do not continue driving! Brake fluid level too low ⇒ <i>Brake fluid level</i>
BRAKE WEAR	Check brake pads ⇒ <i>Brake pad wear indicator</i>
	Take over steering and be ready to brake. ⇒  <i>Introduction</i>
	 Do not continue driving! Oil level too low ⇒ <i>Engine oil level very low</i>















	<p> Do not continue driving!</p> <p>Oil pressure too low ⇒ <i>Engine oil pressure too low</i></p>
	<p> Do not continue driving!</p> <p>Coolant system has malfunctioned ⇒ <i>Coolant</i></p>
	<p> Do not continue driving!</p> <p>Steering malfunction ⇒ <i>Steering malfunction</i></p>
	<p>Rear Traffic Alert has detected an obstacle to the rear ⇒ <i>Rear Traffic Alert</i></p>
	<p> Do not continue driving!</p> <p>Engine control malfunction ⇒ <i>Engine control malfunction</i></p>
	<p> Do not continue driving!</p> <p>Engine control malfunction ⇒ <i>The engine no longer starts automatically</i></p>
	<p> Do not continue driving!</p> <p>12 V power supply has malfunctioned ⇒ <i>12-volt power supply</i></p>
	<p>Collision warning ⇒ <i>Warning levels and braking support</i></p>
	<p>Take over the steering immediately ⇒ <i>Take over the steering immediately</i></p>
	<p> Do not continue driving!</p> <p>Transmission overheating ⇒ <i>Transmission overheating</i></p>
	<p> Do not continue driving!</p> <p>Transmission malfunction ⇒ <i>Transmission malfunction</i></p>
	<p>Central warning lamp ⇒ <i>Priority 2 warning message</i></p>
	<p>Airbag or Safety Belt Pretensioner with Diagnostic Device Switched off ⇒ <i>Airbag System or Safety Belt Pretensioner deactivated with Diagnostic Device</i></p>
	<p>Airbag or Safety Belt Pretensioner Malfunction ⇒ <i>Airbag System or Safety Belt Pretensioner Malfunction</i></p>

	Indicator light for front passenger's front airbag malfunction ⇒ <i>Indicator light for front passenger's front airbag malfunction</i>
OFF 	Front passenger's front airbag switched off ⇒ <i>Front passenger's front airbag switched off</i> , ⇒ <i>Front passenger's front airbag switched off</i>
ON 	Front passenger's front airbag enabled ⇒ <i>Front passenger's front airbag enabled</i>
	Emergency Call Service limited ⇒ <i>Emergency Call Service limited</i>
	Emergency Call Service faulty ⇒ <i>Emergency Call Service malfunction</i>
	Electronic parking brake malfunction ⇒ <i>Electronic parking brake malfunction</i>
	Comes on: Electronic Stability Control (ESC) malfunction ⇒ <i>ESC malfunction</i>
	Blinking: Electronic Stability Control (ESC) or anti-slip regulation (ASR) is active ⇒ <i>Electronic Stability Control (ESC)</i>
	ESC Sport switched on ⇒ <i>ESC Sport</i>
	Electronic Stability Control (ESC) switched off ⇒ <i>ESC Off</i>
	Anti-Slip Regulation (ASR) switched off ⇒ <i>ASR</i>
ABS	Anti-Lock Braking System (ABS) malfunction ⇒ <i>ABS failure or malfunction</i>
	Engine oil system malfunction ⇒ <i>Engine oil system malfunction</i>
	Engine oil level too low ⇒ <i>Engine oil level too low</i>
	Engine oil level too high ⇒ <i>Engine oil level too high</i>
	Engine oil system malfunction ⇒ <i>Engine oil system malfunction</i>
	Fuel tank almost empty ⇒ <i>Fuel tank almost empty</i>

	Semi-automated driving assistance (Travel Assist) not available ⇒ <i>Comfort drive Travel Assist is not available or is not working as expected</i>
	Tank cap not closed ⇒ <i>Fuel tank cap open</i>
	Exterior lighting malfunction ⇒ <i>Exterior lighting malfunction</i>
	Rain/light sensor malfunction ⇒ <i>Rain/light sensor malfunction, ⇒ Rain/light sensor malfunction</i>
	Windshield wiper malfunction ⇒ <i>Windshield wiper malfunction</i>
	Washer fluid level too low ⇒ <i>Washer fluid level too low</i>
	Steering malfunction ⇒ <i>Steering malfunction</i>
	Tire pressure low ⇒ <i>Tire pressure low</i>
	Tire pressure monitoring system malfunction ⇒ <i>Tire pressure monitoring system malfunction</i>
	Engine control malfunction ⇒ <i>Engine control malfunction</i>
	No or restricted sensor range of the driver assistance systems ⇒ <i>No forward sensor range or limited forward sensor range</i>
	Autonomous Emergency Braking (Front Assist) not available ⇒ <i>Automatic Emergency Braking</i>
	Autonomous Emergency Braking (Front Assist) switched off ⇒ <i>Using Front Assist</i>
	Adaptive Cruise Control (ACC) not available ⇒ <i>ACC is not available</i>
	Semi-automated vehicle assistance in a medical emergency (Emergency Assist) not available ⇒ <i>Semi-automated vehicle assistance in a medical emergency</i>
	Lane Assist not available ⇒ <i>Lane Assist not available</i>
	Emergency Assist regulating ⇒ <i>Driving with Emergency Assist</i>

	Lane Assist regulating ⇒ <i>Driving with Lane Assist</i>
	Side Assist malfunction ⇒ <i>Side Assist malfunction</i>
	Rear Traffic Alert brakes ⇒ <i>Automatic braking intervention</i>
	Exit warning system malfunction ⇒ <i>Rear Traffic Alert malfunction</i>
	Exhaust system malfunction ⇒ <i>Exhaust-related malfunction</i>
	Particulate filter clogged with soot ⇒ <i>Particulate filter clogged with soot</i>
	Engine speed limited ⇒ <i>Engine speed limited</i>
	12-volt power supply malfunction ⇒ <i>12-volt power supply</i>
	Risk of rolling away! P unavailable ⇒ <i>unavailable</i>
	Transmission in emergency mode ⇒ <i>Transmission in emergency mode</i>
	Transmission malfunction ⇒ <i>Transmission malfunction</i>
	Selector lever malfunction ⇒ <i>Selector lever malfunction</i>
	Transmission overheating ⇒ <i>Transmission overheating</i>
	Vehicle key not in the vehicle ⇒ <i>Valid vehicle key cannot be detected</i>
	Rear Traffic Alert malfunction ⇒ <i>Rear Traffic Alert malfunction</i>
	Press the brake pedal. ⇒ <i>The engine is not starting</i>
	Turn signal ⇒ <i>Turn signal indicator light</i>
	Trailer turn signal ⇒ <i>Trailer turn signal indicator light</i>
	Lane Assist active ⇒ <i>Driving with Lane Assist</i>

	Semi-automated driving assistance (Travel Assist) active ⇒ Introduction
	Adaptive Cruise Control (ACC) regulates, no vehicle driving ahead is detected ⇒ Switching ACC on and off
	Adaptive Cruise Control (ACC) regulates, vehicle driving ahead is detected ⇒ Switching ACC on and off
	Hill Descent Control is active ⇒ Hill Descent Control
	Main beam or headlight flasher ⇒ Switching the high beam headlights on and off
	High beam control (Light Assist) switched on ⇒ Switching on high beam control
	Adaptive Cruise Control (ACC) is not regulating; a vehicle is detected driving ahead ⇒ Switching ACC on and off
	Adaptive Cruise Control (ACC) is not regulating; no vehicle is detected driving ahead ⇒ Switching ACC on and off
	Hill Descent Control is not active ⇒ Hill Descent Control
	Semi-automated driving assistance (Travel Assist) inactive, Adaptive Cruise Control (ACC) active, adaptive lane guidance passive ⇒ Introduction
	Outside temperature is below +4 °C (+39 °F) ⇒ Volkswagen Digital Cockpit information displays
	Start/Stop system active ⇒ Start-stop system
	Start/Stop system not available ⇒ Start-stop system
	Service due ⇒ Service interval display
	High beam control (Light Assist) active ⇒ High beam assistance (Light Assist)
	Take over the steering ⇒ Take over the steering

	Autonomous Emergency Braking (Front Assist) starts ⇒ Automatic Emergency Braking starts
	Distance warning ⇒ Warning levels and braking support
	Offroad driving mode ⇒ Driving mode properties
	Eco driving mode ⇒ Driving mode properties
	Normal driving mode ⇒ Driving mode properties
	Sport driving mode ⇒ Driving mode properties
	Individual driving mode ⇒ Driving mode properties
	Snow driving mode ⇒ Driving mode properties
	Mobile phone battery charge level ⇒ Volkswagen Digital Cockpit information displays
	Note about information in the Owner's Manual ⇒ Note about information in the Owner's Manual
	Adjustment due to the road layout ⇒ Driving with predictive cruise control
	Speed adjustment due to a speed restriction ⇒ Driving with predictive cruise control
	Rear seat information muted ⇒ Parking
	Mobile phone connected via Bluetooth® ⇒ Volkswagen Digital Cockpit information displays

Warning and information texts

The status of some functions inside the vehicle and vehicle components are checked when the ignition is switched on or while driving. Malfunctions are indicated by red and yellow warning symbols in the instrument cluster display and may also be signaled audibly in some cases. The appearance of texts and symbols may vary depending on the instrument cluster version.

Any malfunctions currently occurring can also be manually called up. To do this, open the Vehicle status or Vehicle menu ⇒ [Vehicle settings menu](#).

 Priority 1 warning message

The red central warning light flashes or comes on, in some cases together with warning tones or additional symbols.  **Do not continue driving!** There is a hazard. Check the malfunction. Contact an authorized Volkswagen dealer or authorized Volkswagen Service Facility immediately for assistance.

Priority 2 warning message

The yellow central warning light flashes or comes on, in some cases together with warning tones or additional symbols. Malfunctions or insufficient operating fluids can cause vehicle damage and vehicle malfunctions. Check the malfunction as soon as possible. Immediately contact an authorized Volkswagen dealer or authorized Volkswagen Service Facility to have the system checked. Volkswagen recommends contacting an authorized Volkswagen dealer or authorized Volkswagen Service Facility.

Note about information in the Owner's Manual

You can find more information about the existing warning message in the Owner's Manual.

Informational text

Information about various processes in the vehicle.

 If there are multiple warning messages, the symbols will appear consecutively for several seconds. The symbols will appear until the malfunction is corrected.

 If warning messages about malfunctions appear when the ignition is switched on, settings or information displays may not appear as described. If the malfunction persists, contact a suitably qualified professional. Volkswagen recommends contacting an authorized Volkswagen dealer or authorized Volkswagen Service Facility.

Introduction to the instrument cluster

The vehicle is equipped with a Volkswagen Digital Cockpit. The instrument cluster shows essential information, such as speed.

In addition, the following functions, among others, are available depending on the equipment:

- Various menus, such as for the driver assistance systems.
- Status displays for the driver assistance systems.
- Display messages.
- Warning and indicator lights.
- Information about economy and range.

Content can be individually adapted and settings can be changed in the menus.

WARNING

Operating the Volkswagen Digital Cockpit and Infotainment system can distract you from traffic. If the driver is distracted while driving, accidents and serious or fatal injuries can occur.

- Always drive attentively and responsibly.
- Never operate the instrument cluster while driving.
- Only adjust any settings in the instrument cluster or Infotainment system when the vehicle is stationary.

WARNING

If there is a serious fault in the instrument cluster, the display may be turned off. The red central warning light  may also come on. No further warnings can be displayed. This may result in vehicle breakdowns while driving, accidents and serious or fatal injuries.

- Safely stop the vehicle.

- See an authorized Volkswagen dealer or authorized Volkswagen Service Facility for assistance.

i After starting the engine when the 12 V vehicle battery is severely drained or when it has been replaced or jump-started, the system settings, e.g. personal convenience settings and programming, and user profiles may be changed or erased. Check and correct the settings after the 12 V vehicle battery is sufficiently recharged.

i In very low outside temperatures, the indicators on the instrument cluster display may take slightly longer to turn on than in warm outside temperatures.

Digital Instrument cluster

Volkswagen Digital Cockpit overview

The Digital Cockpit is a digital instrument cluster with a high-resolution TFT color display. By selecting different secondary displays, other displays can be shown in addition to the standard dials, such as the tachometer. The term “Volkswagen Digital Cockpit” is used to refer to the digital instrument cluster in the following.

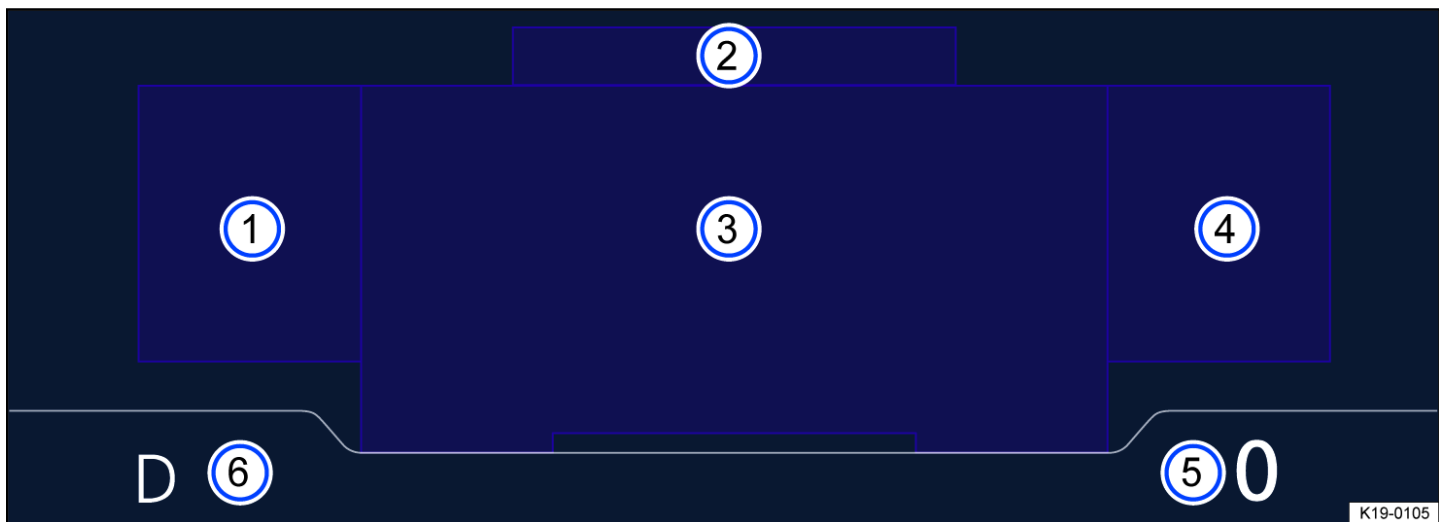

Fig. 9 In the instrument panel: digital instrument cluster (general example).

- ① Secondary displays.
- ② Pop-ups: Situation-related messages, e.g. navigation information.
- ③ Main display area.
- ④ Secondary displays.
- ⑤ Digital speed display.
- ⑥ Currently engaged gear or selector lever position.

Operating the Digital Instrument Cluster



Fig. 10 Right side of the multi-function steering wheel: Operating the Volkswagen Digital Cockpit (variant 1).

Menus cannot be opened when a priority 1 warning message is displayed → page , *Warning and information texts*. You can confirm and hide some messages using the **OK** button on the multi-function steering wheel *fig. 10*.

Views in the Display Area

1. Press the **VIEW** button to switch the main display ⇒ *Volkswagen Digital Cockpit overview*.

The following views can be shown in the display area:

Summary Before starting and after switching off the engine: Display with information about the vehicle status, e.g. total mileage.





Classic Display of dials.

Navigation Navigation map and route guidance information.

Driver assistance systems Display of the active driver assistance systems.

Special Depending on vehicle equipment, it may be possible to display alternative displays here, e.g. sport displays.

Selecting secondary displays





1. Select the right or left secondary display area using the  or  buttons.
2. Select the preferred secondary display using the  and  arrow buttons.
3. Confirm your selection with the **OK** button.

Showing and Hiding the Secondary Displays

1. Press and hold the **VIEW** button.

Configuring secondary displays

You can configure the secondary displays to select which secondary displays are available in the secondary display area:

1. Select the right or left secondary display area using the  or  buttons.
2. Use the  and  arrow buttons to navigate to the Settings menu and open it.
3. Press the **OK** button to apply changes.

A check mark indicates that the respective secondary display is activated.

4. To return to the menu selection, press the  or  button.

 The secondary displays can be configured or hidden independently of each other.

Navigation map in the digital instrument cluster

Depending on the vehicle equipment, the digital instrument cluster may display a detailed navigation map.

The size of the navigation map can be adjusted continuously. To select the desired map size, proceed as follows:

1. To open the Navigation display area, press the **VIEW** button.
2. Press the  or  arrow buttons on the multi-function steering wheel to zoom in or out.
3. Press and hold the **VIEW** button on the multi-function steering wheel to show or hide the secondary displays.

 If warning messages about malfunctions appear when the ignition is switched on, settings or information displays may not appear as described. If the malfunction persists, contact a suitably qualified professional. Volkswagen recommends contacting an authorized Volkswagen dealer or authorized Volkswagen Service Facility.

WARNING

Operating the Volkswagen Digital Cockpit and Infotainment system can distract you from traffic. If the driver is distracted while driving, accidents and serious or fatal injuries can occur.

- Always drive attentively and responsibly.
- Never operate the instrument cluster while driving.
- Only adjust any settings in the instrument cluster or Infotainment system when the vehicle is stationary.

Volkswagen Digital Cockpit information displays

Possible displays in the main display area of the digital instrument cluster

Depending on the vehicle equipment, different information can be displayed in the main display area ⇒ [Volkswagen Digital Cockpit overview](#):

- Outside temperature display.
- Time and date.
- Detected road sign from the traffic sign recognition.
- Driver assistance systems ⇒ [Driver assistance systems](#).
- Open doors, hood and trunk lid.
- Speed warning for winter tires.
- Infotainment system and navigation information.

- Radiator fan run-on.
- Engine code (EC).
- Range ⇒ *Digital fuel gauge*.
- Service interval display.
- Depending on the vehicle equipment: Status display for Active Cylinder Management (ACT) ⇒ *Eco tips*.
- Selector lever position for automatic transmission.
- Warning and information texts.
- Warning and indicator lights.

Outside temperature display

When outside temperatures are colder than approximately +4 °C (approximately +39 °F), a snowflake symbol ❄ also appears on the outside temperature display. This symbol remains on until the outside temperature rises above +6 °C (approximately +43 °F).

In the following situations, the temperature displayed may be higher than the actual outside temperature due to heat radiating from the engine:

- When the vehicle is stationary
- When the driving speed is very low

The measurement range is from -50 °C (approximately -58 °F) to +75 °C (approximately +167 °F).

WARNING

Roads may be icy when outside temperatures are low, even if they are above the freezing point. There is an increased risk of an accident on icy roads. This could result in serious or fatal injuries.

- If the ❄ symbol is displayed in the instrument cluster display, drive with extra caution.
- Always adapt your speed and driving style to the visibility, weather, road and traffic conditions.
- Never rely solely on the outside temperature display.

Open doors, hood and trunk lid

If, after unlocking the vehicle and while driving, any doors and/or the hood or trunk lid are open, this is displayed in the Volkswagen Digital Cockpit and an audible signal may also sound.

Speed warning for winter tires

If the set maximum speed is exceeded, this will be shown in the digital instrument cluster.

Settings for the speed warning can be adjusted in the vehicle settings in the Infotainment system ⇒ *Vehicle settings menu*.

Radiator fan run-on

This indicator appears after the engine has been switched off, if the radiator fan continues to run.

The radiator fan may continue running due to:

- Exhaust gas post-treatment, through particulate filter regeneration, for example.
- Active brake cooling after descent.
- Dissipation of engine heat after high load, e.g. trailer mode.

Engine code (EC)

1. Open the service menu ⇒ [Service menu](#).
2. Select the Engine code menu item.

Selector lever position for automatic transmission

The selector lever position and, depending on the driving mode, the gear that is engaged, are shown on the selector lever and in the Volkswagen Digital Cockpit. The gear shift pattern is displayed when the brake or the selector lever in the instrument cluster is actuated ⇒ [Selector lever](#).

Possible secondary displays in the Volkswagen Digital Cockpit

In the secondary display area of the digital instrument cluster, other views can be configured and displayed via a configuration menu, depending on the vehicle equipment ⇒ [Volkswagen Digital Cockpit overview](#):

- Operating temperatures.
- Time and date.
- Driving data menus, e.g. Travel time/distance driven.
- Compass display.
- Charge pressure.
- Output.
- Torque splitter.
- Navigation information.
- Phone information.
- Destination information.

Operating temperatures

Depending on the vehicle equipment, the following operating temperatures may be displayed:

- Engine oil.
- Engine coolant.
- Transmission.

Compass display

If the Compass secondary display is activated, the direction in which you are currently driving is shown as a blue arrow with a depiction of the vehicle and a compass.

Torque splitter

In the Torque splitter secondary display, the current torque for each wheel is displayed.



Navigation information

When route guidance is activated, the Navigation instruction auxiliary display shows the direction of travel as an arrow.

The submenu lists your home address and a list of your most recent destinations. Route guidance can be started with the

 button ⇒ [Navigation](#).

Phone

If the Phone secondary display is activated and a cell phone is connected via Bluetooth, the Bluetooth symbol  will be displayed in the Volkswagen Digital Cockpit display. The  symbol also indicates the charge level of the mobile device.

In the submenu, a list of the most recent phone calls is shown and you have the option to call the displayed contacts back.

Destination information

When route guidance is activated, the Destination information secondary display shows the predicted journey time and distance from the destination in km or miles.

 Some displays in the Volkswagen Digital Cockpit may be hidden due to events that occur suddenly, e.g. incoming phone calls.

 Depending on the equipment, some settings and displays may also appear in the Infotainment system.

Tachometer

The start of the red area on the tachometer indicates the maximum permissible engine speed for all gears when the engine is run in and at operating temperature.

Before reaching the red area, shift to the next highest gear, select the selector lever position D/S or take your foot off the accelerator pedal.

NOTICE

To prevent engine damage, the tachometer indicator may only be in the red area of the scale briefly. A heavy engine load, especially when the engine is cold, can lead to engine damage.

- Avoid high engine speeds, harsh acceleration and heavy engine loads when the engine is cold.

 Shifting up early helps save fuel and reduce operating noises.

Fuel gauge

Digital fuel gauge



Fig. 11 In the digital instrument cluster: fuel gage (general example).

 The small arrow next to the fuel pump symbol on the fuel gauge indicates which side of the vehicle the fuel filler flap is on.

Troubleshooting

 Fuel tank almost empty

The yellow indicator light turns on. The reserve supply (red marking) is being used.

1. Refuel at the next opportunity.

Fuel tank cap open

The yellow indicator light turns on.

1. Close the fuel tank cap.

WARNING

If the fuel level is too low, this can result in irregular fuel supply and cause the engine to “sputter” or cut out, particularly when traveling uphill or downhill. The steering, all driver assistance systems and brake support systems will not work if the engine cuts out due to fuel shortage or irregular fuel supply. This may result in vehicle breakdowns while driving, accidents and serious or fatal injuries.

- Check that the fuel tank is always sufficiently filled.
- Always refill the fuel when the fuel tank is only 1/4 full.

NOTICE

Irregular fuel supply can result in misfiring and unburnt fuel entering the exhaust system.

- Never drive with a completely empty fuel tank.

Engine coolant temperature display

Digital Engine Coolant Temperature Display

Depending on the vehicle equipment, the coolant temperature for engine cooling may be displayed in the Operating temperatures secondary display.

If the red warning light  comes on, the engine coolant temperature is too high or the engine coolant level is too low
⇒ [Troubleshooting](#).

Head-up display (HUD)

Introduction

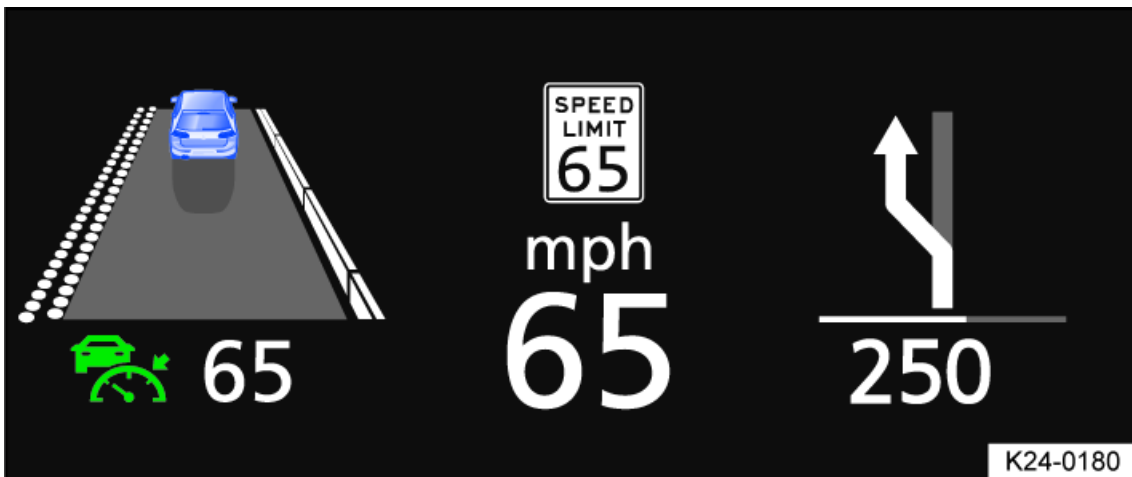





Fig. 12 In the driver's field of vision: indicators on the head-up display (general example).

The head-up display projects selected information displays or warning messages from assist systems or from the Infotainment system in the visual range of drivers.

 Some display contents cannot be hidden, such as warning messages.

 The brightness of the display reduces automatically as the ambient brightness decreases. The basic brightness is set together with the instrument illumination ⇒ *Instrument and switch illumination*.

 Reflections are possible due to unfavorable sunlight.

 Sunglasses with polarization filters can negatively influence the readability.

 The optimal readability of the head-up display depends on the position of the seat and the height adjustment of the head-up display.

Operating the Head-Up Display

Switching the head-up display on and off

The head-up display (HUD) can be switched on and off using the vehicle settings in the Infotainment system.

Height adjustment

To individually adapt the angle of view, set the head-up display in the corresponding menu on the instrument cluster or in the vehicle settings of the Infotainment system:

1. Setting the optimal seat position.
2. Set your preferred position and inclination of the head-up display with the function keys or the buttons on the multi-function steering wheel.

The rotation can also be adjusted in the vehicle settings of the Infotainment system.

Settings in the Infotainment system

Additional settings for the head-up display can be adjusted in the Vehicle menu in the Infotainment system.

1. In the Vehicle menu, select the Inner view.
2. Tap the Head-up display function key.

Additional settings are available:

- Setting the brightness of the head-up display.
- Selection of the display contents for the head-up display, e.g. driver assist system or Infotainment system displays.
- Alternative head-up display colors in poor weather conditions, e.g. snow.

Driving data menu

The driving data menu shows driving and consumption data, such as the driving duration or kilometers driven. Multiple driving data displays are available in the auxiliary display area ⇒ *Digital Instrument cluster*, ⇒ *Volkswagen Digital Cockpit information displays*.

Depending on the vehicle equipment, various driving data can be displayed. The displayed driving data is dependent on the current driving style, the vehicle status, e.g. particle filter regeneration, and the current driving situation, e.g. city traffic. The driving data is determined as an average value over sections of different distances and the currently displayed value may therefore differ from the actual average value.

Since start memory

If the trip is interrupted for more than two hours, the memory is erased.





Since refuel memory

Display and memory of the collective driving and consumption data. The memory is erased when the vehicle is refueled.

Extended period memory

The memory stores driving statistics for up to 100 minutes of travel time or a driving distance of 9999.9 km (mi). If one of these maximum thresholds is met, the memory is erased. The maximum thresholds may vary depending on the version of the instrument cluster.

Reset driving data menus

1. Press the  or  button.
2. Select the corresponding driving data menu in the configuration menu with the  and  arrow buttons.
An arrow behind the entry in the configuration menu indicates a submenu.
3. In the submenu, select Reset data and confirm by pressing the  button.

Resetting the trip odometer

1. Tap the Vehicle function key in the Infotainment system.
2. In the Vehicle menu, tap the Status function key.
3. Tap the Distance driven function key.
4. Tap the  function key to reset the value.

WARNING

If the driver is distracted while driving, accidents and serious injuries can occur. Operating the Volkswagen Digital Cockpit and Infotainment system can distract you from traffic.





- Always drive attentively and responsibly.
- Never operate the instrument cluster while driving.
- Only adjust any settings in the instrument cluster or Infotainment system when the vehicle is stationary.

Service

Service menu

Depending on the equipment, settings can be applied in the service menu.

Opening the Service Menu

1. Open the Travel time/distance information profile in the secondary displays.
2. Press and hold the  or  button on the multi-function steering wheel for approximately six seconds.
3. Use the  and  arrow buttons to navigate the menu.

Opening the service interval status

1. Open the Service menu.

An overview of the remaining distance and days until the next inspection service or the next oil change service is shown in the instrument cluster display.

Resetting the service interval display

1. Open the Service menu.
2. Follow the instructions in the instrument cluster display.

Resetting the oil change service



1. Open the Reset oil change service menu.
2. Follow the instructions in the instrument cluster display.

Displaying the Engine Code (EC)

1. Open the Engine code menu.

The engine code is shown on the instrument cluster display.

Setting the time

1. Open the Time menu.
2. Set the time with the  and  arrow buttons.

Displaying copyright information

1. Open the Copyright menu to access the copyright information.

Service interval display

Displays about service events appear in the Volkswagen Digital Cockpit and in the Infotainment system. There are different versions of the Volkswagen Digital Cockpit and Infotainment system; therefore, the appearances of the displays may vary.

Service appointments at Volkswagen are divided into oil change services and inspections. The service interval display informs the driver about the next service appointment which includes an engine oil change and about the next inspection.

The service intervals are specified for vehicles with the fixed oil change service interval.

Intervals are determined individually on vehicles with the flexible oil change service interval. Oil change services only need to be performed if the vehicle requires it. The specific operating conditions and the personal driving style are also taken into consideration. The service early warning message is first displayed 30 days prior to the calculated oil change service due date. The displayed remaining distance to be traveled is always rounded to 100 km (miles) and the remaining time is rounded to whole days.

Service notification

If an oil change service or an inspection service is due in the near future, a service notification will be displayed when the ignition is switched on.

The specified mileage or time is the distance or time until the next service can be completed.

Service event

When an oil change service or an inspection service is due, a chime will sound when switching on the ignition and you can then see a wrench symbol  for a few seconds in the instrument cluster display together with one of the following displays:

- Please have an inspection service performed.
- Oil change service due!
- Oil change service and inspection service due!

Checking a service due date

When the ignition is on, the engine is off and the vehicle is stationary, the current service due date can be checked:

1. Tap the Vehicle function key.
2. Open the Status menu and tap the Service function key to display the service information.

The service due date can also be checked via the service menu ⇒ [Service menu](#).



Resetting the service interval display

If the service interval display was not reset after the oil change service or inspection service, the display can be reset as follows:

The service interval display can only be reset through the service menu ⇒ [Service menu](#).

Do not reset the service interval display between service intervals or incorrect information will be displayed.

If the oil change service interval was manually reset, the service interval display then also switches to a fixed service interval, even on vehicles with the flexible oil change service interval.

 The service message disappears automatically after a few seconds when the engine is running or when the  button on the multi-function steering wheel is pressed.

 If the 12 V vehicle battery in a vehicle with the flexible oil change service interval has been disconnected for an extended period, the time for the next oil change service cannot be calculated. Therefore, the service interval displays may show incorrect calculations. If this is the case, follow the maximum permissible service intervals.

Displaying Vehicle identification number

1. Tap the Vehicle function key in the Infotainment system.
2. In the Vehicle menu, tap the Status function key.
3. To display the vehicle identification number (VIN), tap the Service function key.

The vehicle identification number (VIN) is displayed.



Time and date

Setting the time and date in the Infotainment system

1. Tap the  function key ⇒ [Vehicle settings menu](#).
2. Select the Time and date menu to set the time and date.
3. Select time source:
 - Automatic.
 - Manual.

 The time and date are only displayed in the Infotainment system.

Setting the time in the Volkswagen Digital Cockpit

1. Open the service menu ⇒ [Service menu](#).
2. Open the Time menu.
3. Set the time with the  and  arrow buttons.

Exit menu

You can adjust the settings of some functions in the exit menu before leaving the vehicle. The exit menu will be displayed in the Infotainment system when you switch off the ignition.

The entries shown depend on the vehicle equipment and may only be available under certain conditions.

Hide



The exit menu is automatically hidden when you leave the vehicle.

1. To hide the exit menu manually, tap .

 The exit menu can be opened again by switching on the ignition and switching it off again immediately.

Settings

You can select the entries individually and arrange their order.

1. Tap .
2. Select the entries as desired and rearrange their order if necessary.
3. Tap  again.







Vehicle settings menu

You can switch individual functions and systems on and off and adjust settings in the vehicle settings menu in the Infotainment system.

General information for operation

The activated functions are highlighted in color.

Opening the Vehicle settings Menu

1. Switch the ignition on.
2. If necessary, switch on the Infotainment system.
3. Tap the  function key.
4. Depending on the equipment: Tap the  menu item and choose between the  and  function keys.
Or: select the  menu item.
5. Open the preferred item from the submenus and set as desired.
6. To return to the home screen, tap the home button .

System settings and vehicle information display

Depending on the version, information can be displayed or settings set in the Vehicle settings menu:

- Depending on the vehicle equipment: 3D vehicle view (Interior or Exterior).
- Depending on vehicle equipment: Performance monitor.
- Depending on vehicle equipment: Lap timer.
- Driving Data.
- Vehicle status.

 After starting the engine when the 12 V vehicle battery is severely drained or has been replaced or jump-started, system settings, e.g. personal convenience settings and programming, may be adjusted or deleted. Check and correct the settings after the 12 V vehicle battery is sufficiently recharged.

WARNING

Operating the Infotainment system can distract you from traffic. If the driver is distracted, accidents and serious or fatal injuries can occur.

- Always drive attentively and responsibly.
- Adjust settings in the Infotainment system only when the vehicle is stationary.

Dynamic Road Sign Display

Introduction

The Dynamic Road Sign Display detects standard road signs using a camera in the interior rearview mirror base and informs the driver of detected speed limits and passing restrictions. Within the system limits, the system also displays an additional sign to indicate special restrictions. The system may also continue to display the valid speed limit on roads without signs.

The traffic signs recorded by the Dynamic Road Sign Display are shown in the display of the Volkswagen Digital Cockpit. Depending on the Infotainment system installed in the vehicle, the road signs may also be displayed there.

Depending on the vehicle equipment, a display may also appear in the head-up display (HUD).

Dynamic Road Sign Display is always active when the ignition is started.

Road sign display

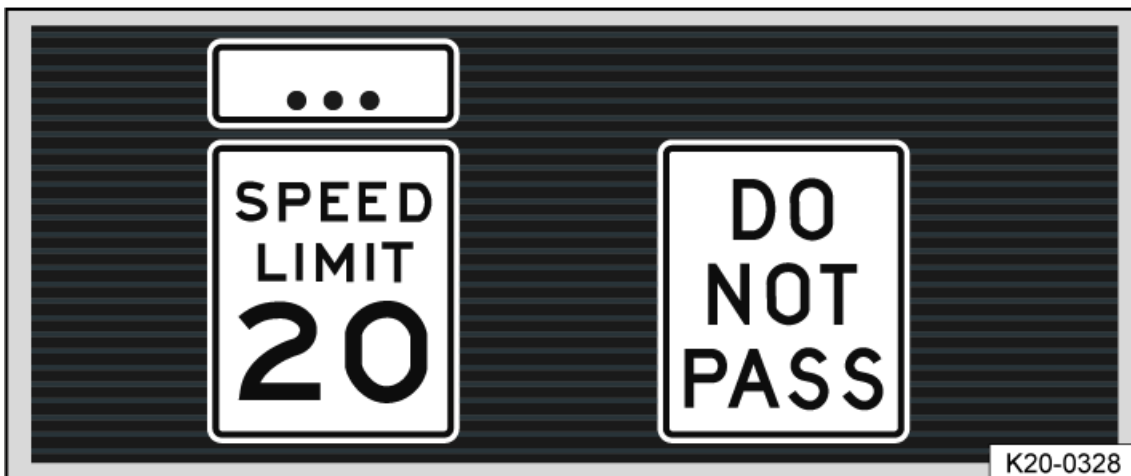

Fig. 13 In the instrument cluster display: recognized speed limits (general example).

After checking and evaluating the information from the camera, the Infotainment system, and the current vehicle data, the Dynamic Road Sign Display function displays up to two valid traffic signs and a generic additional sign [fig. 13](#):

1st position: The road sign that is currently valid is shown on the left-hand side of the display, for example a speed limit of 20 mph (approx. 35 km/h).

2nd position: Another road sign can be displayed in the second position, such as a passing restriction.

Additional signs: A recognized additional sign is displayed above the applicable traffic sign. Depending on the system, a generic additional sign is displayed instead of the actually recognized additional sign. The applicable traffic sign in the display of the instrument cluster is supplemented by the generic additional sign.

WARNING

The Dynamic Road Sign Display is not a replacement for the driver's attention and works only within the system limitations. This means that the Dynamic Road Sign Display cannot detect all road signs and may not react, or may react

with a delay, or may react in a way that is not desired. Driving recommendations and road signs displayed in the Dynamic Road Sign Display may differ from the actual traffic situation. There is a risk of accidents or even death.

- Observe the system limitations ⇒ *Limits of the Dynamic Road Sign Display* .
- Always stay attentive and do not rely solely on the system. The driver is always responsible for control of the vehicle.
- Traffic signs on the roads and traffic regulations must always take precedence over driving recommendations and displays from the Dynamic Road Sign Display function.
- Always adapt your speed and driving style to the visibility, weather, road and traffic conditions.

Limits of the Dynamic Road Sign Display

📖 Please read the introductory information and heed the Warnings and Notice ⇒  *Introduction*.

Error messages

No road signs available. The system is in the initialization phase.

Or: the vehicle has not detected any road signs.

Error: Dynamic Road Sign Display. System malfunction. If the malfunction persists, contact a suitably qualified professional. Volkswagen recommends contacting an authorized Volkswagen dealer or authorized Volkswagen Service Facility.

Speed Alert currently not available. The speed alert from the Dynamic Road Sign Display is malfunctioning. If the malfunction persists, contact a suitably qualified professional. Volkswagen recommends contacting an authorized Volkswagen dealer or authorized Volkswagen Service Facility.

Dynamic Road Sign Display: Clean windshield! The windshield is dirty in the area around the camera or weather conditions are interfering with the camera view. Clean the windshield.

Dynamic Road Sign Display is currently limited. Data is not being transmitted by the Infotainment system. Check that valid map data is loaded in the Infotainment system.

Or: the vehicle is located in an area that is not detected on the map stored in the Infotainment system.

No data available. The Dynamic Road Sign Display function is not supported in the country where the vehicle is currently being operated.

Functional limitations

The Dynamic Road Sign Display is subject to system limitations. The following conditions may cause the Dynamic Road Sign Display function to be limited or to not operate at all:

- High ambient temperature or long exposure to direct sunlight.
- Poor visibility, such as in snow.
- Glare, for example from oncoming traffic or the sun
- High speeds
- If the camera is obstructed or dirty
- If road signs are outside of the camera's visual field
- If road signs are partially or completely covered, for example by trees, snow, dirt, or other vehicles.
- If road signs are not in the standard format
- If there are damaged or bent road signs
- If there are variable traffic signs on overhead signs (variable display of road signs by LED s or other lighting).

- If there is outdated map material in the Infotainment system
- If there are stickers on vehicles that indicate road signs, such as speed limits on commercial vehicles

Operating the Dynamic Road Sign Display

📖 Please read the introductory information and heed the Warnings and Notice ⇒  [Introduction](#).

Speed warning

If the Dynamic Road Sign Display function detects that a valid speed limit is being exceeded, it may warn the driver audibly or visually with a message in the instrument cluster display.

The speed warning can be set or completely deactivated in the Infotainment system in the Assistance systems menu ⇒ [Vehicle settings menu](#). The speed warning can be set to a value of 0 km/h (0 mph), 5 km/h (3 mph) or 10 km/h (5 mph) above the maximum permissible speed.

Trailer mode

On vehicles with a trailer hitch installed at the factory and a trailer that is connected to the vehicle electrical system, the display of road signs relevant to a trailer, such as the valid speed limit and passing restrictions for vehicles with a trailer, can be activated and deactivated in the vehicle settings in the Infotainment system ⇒ [Vehicle settings menu](#).

For trailer mode, the display of valid speed limits can be adjusted to the model of the trailer and to the legal regulations. The setting can be set in increments of 10 km/h (5 mph) within a range of approx. 60 km/h (35 mph) and approx. 130 km/h (80 mph). If a speed is set that is higher than the permitted speed for driving with a trailer in the country or state where the vehicle is being operated, the Dynamic Road Sign Display function will automatically display the legal speed limit, for example approx. 80 km/h (50 mph) in California.

Safety

General information

Driving preparations and driving safety

Observe the following points before and during every trip, for your own safety and for the safety of your passengers and other on the road ⇒ :

- ✓ Make sure the vehicle lighting and turn signals are functioning correctly.
- ✓ Check the tire pressure and fuel level ⇒ *Checking the tire pressure*, ⇒ *Fuel gauge*.
- ✓ Check the washer fluid level ⇒ *Washer fluid*.
- ✓ Ensure that the windows are clear and provide good visibility ⇒ *Exterior care and cleaning*.
- ✓ The air intake for the engine must not be blocked. The engine must not be covered with covers or insulation ⇒ *Safety precautions for working in the hood space*.
- ✓ Secure all objects and luggage in the storage compartments and the luggage compartment ⇒ *Transporting*.
- ✓ It must be possible to press the pedals without interference.
- ✓ Secure children with child restraint systems that are appropriate for their weight and height ⇒ *Transporting children safely*.
- ✓ Adjust the front seats, head restraints, and mirrors according to the size of the occupants ⇒ *Seating position*, ⇒ *Mirrors*.
- ✓ Wear shoes that give your feet good grip for operating the pedals.
- ✓ The floor mat in the driver side footwell must be kept clear from the pedal area and be secured.
- ✓ Assume the correct seating position before driving and remain that way while driving. This also applies to all passengers ⇒ *Seating position*.
- ✓ Fasten the safety belt correctly before you begin driving and keep it fastened while driving. This also applies to all passengers ⇒ *Safety belts*.
- ✓ The number of passengers must not exceed the number of seats and safety belts.
- ✓ Never drive when impaired, for example by medication, alcohol, or drugs.
- ✓ Never allow yourself to be distracted from traffic, such as by adjusting settings, by opening menus, by passengers, or by phone calls.
- ✓ Always adapt your speed and driving style to the current visual, weather, road, and traffic conditions.
- ✓ Follow driving rules and posted speed limits.
- ✓ Take regular breaks on long trips. You should take a break at least every two hours.
- ✓ Secure animals in the vehicle restraint systems that are appropriate for their weight and size.

Driving in other countries

Some countries have special safety standards and regulations that differ from the vehicle configuration. Volkswagen recommends that you inform yourself about legal regulations and about the following points from an authorized Volkswagen dealer or authorized Volkswagen Service Facility before driving in other countries. Volkswagen recommends contacting an authorized Volkswagen dealer or authorized Volkswagen Service Facility.

- ✓ Do technical modifications need to be made to the vehicle before driving in other countries, such as covering or adjusting the headlights?
- ✓ Are the tools, diagnostic equipment, and replacement parts that are needed for maintenance and repair work

available?

- ✓ Is there an authorized Volkswagen dealer or authorized Volkswagen Service Facility in the country where you will be driving?
- ✓ Are fluids that meet Volkswagen specifications available in the country where you will be driving ⇒ *Operating fluids and operating equipment?*
- ✓ Will the navigation function in the factory-installed Infotainment system work with the existing navigation data in the country where you will be driving?
- ✓ Are special tires needed in the country where you will be driving?
- ✓ Is a fire extinguisher required in the country where you will be driving?
- ✓ What are the requirements for a safety vest?
- ✓ Is fuel with sufficient quality available ⇒ *Fuel and emissions control system?*

DANGER

Read and heed the important safety instructions for the front passenger's front airbag ⇒ *Safety notes on using child restraints.*

WARNING

Alcohol, drugs, medication, and prescription narcotics can considerably impair perception, reaction times, and driving safety, which can result in loss of vehicle control. This can cause accidents and serious or fatal injuries.

- Do not drive under the influence of alcohol, drugs, medication or prescription narcotics.

WARNING

Not paying attention to road traffic can cause accidents and serious or fatal injuries.

- Always comply with the applicable driving regulations and speed limits and think ahead while driving.
- Take regular breaks on long drives. You should take a break at least every two hours.

NOTICE

Volkswagen is not responsible for damage to the vehicle caused by substandard fuel, insufficient maintenance, or unsuitable replacement parts.

- Only use fuel that is approved for your vehicle. The factory has placed a fuel information label on the fuel filler flap, which specifies the fuel type to be used for the vehicle.
- Volkswagen recommends the use of Volkswagen original parts or Volkswagen original accessories, which you can acquire from an authorized Volkswagen dealer or authorized Volkswagen Service Facility.

 Having the vehicle serviced regularly not only maintains the value of the vehicle, but also contributes to operational safety and roadworthiness. Therefore, have maintenance procedures performed according to Volkswagen instructions. Under extreme operating conditions, some work may need to be performed before the next service is due. Extreme operating conditions can include frequent “stop-and-go” driving or driving in areas with a lot of dust in the air. For further information, contact an authorized Volkswagen dealer or authorized Volkswagen Service Facility. Volkswagen recommends contacting an authorized Volkswagen dealer or authorized Volkswagen Service Facility.

Seating position

Introduction

Number of seats

Depending on vehicle equipment, the vehicle may have six or seven seats.

	6-seat vehicle	7-seat vehicle
Front seats	2	2
Seats in the second row	2	3
Seats in the third row	2	2



Every seat is equipped with a safety belt.

WARNING

Sitting incorrectly in the vehicle can increase the risk of serious or fatal injuries during sudden driving or braking maneuvers, in the event of a collision or accident, and if the airbags are deployed.

- Before the vehicle starts to move, all vehicle occupants must always be in the correct seating position and maintain it while driving. Safety belts must also be fastened and remain fastened.
- The number of persons in the vehicle must not exceed the number of seats with safety belts.
- Always secure children in the vehicle with an approved and suitable child restraint system according to the child's body size and weight ⇒ *Transporting children safely* and ⇒ *Airbag system*.
- Always keep your feet in the footwell while driving. For example, never rest feet on the seat or on the instrument panel and never stick feet out of the window. Otherwise, if the airbag and the safety belt deploy, they could increase the risk of injury in the event of an accident instead of providing protection.

Risk of injury due to an incorrect seating position

 Please read the introductory information and heed the Warnings and Notice ⇒  *Introduction*.

The risk of serious or fatal injuries will increase if safety belts are not worn or are incorrectly fastened. Safety belts can only achieve the optimum protection if they are routed correctly. An incorrect seating position significantly impairs the protective function of the safety belt. This could result in serious or fatal injuries. The risk of serious or fatal injuries increases even more if a deployed airbag strikes a passenger who is sitting in an incorrect seating position. The driver is responsible for all vehicle occupants and especially for children who are being transported in the vehicle.

The following list includes examples of seating positions that could be dangerous for all vehicle occupants.

The following points always apply when the vehicle is in motion:

- Never stand inside the vehicle.
- Never stand on the seats.
- Never kneel on the seats.
- Never tilt your seat backrest too far back.
- Never lean against the instrument panel.
- Never lay down in the seats in the vehicle interior or on the rear seats.
- Never sit only on the front section of the seat.

- Never sit sideways on the seat.
- Never lean against the window.
- Never place your feet out of the window.
- Never place your feet on the instrument panel.
- Never place your feet on the seat cushion or on the seat backrest.
- Never ride in the footwell.
- Never sit on the armrests.
- Never drive or ride in a seat without fastening your safety belt.
- Never ride in the trunk.

⚠ WARNING

Incorrect seating positions in the vehicle increase the risk of serious or fatal injuries in the event of an accident or sudden driving and braking maneuvers, especially if the airbags are deployed and exert force on a vehicle occupant who is not sitting correctly.

- All vehicle occupants must always sit in the correct seating position and have their own safety belts correctly fastened while driving.

Correct seating position

📖 Please read the introductory information and heed the Warnings and Notice ⇒ ⚠ *Introduction*.

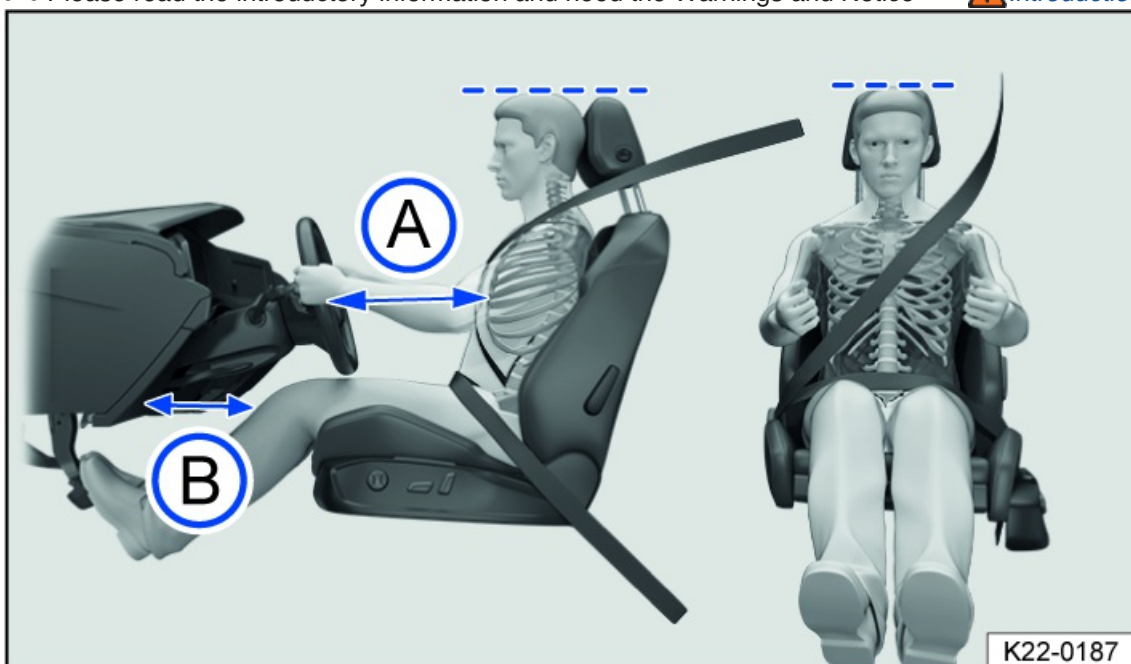

Fig. 14 Correct distance between the driver and the steering wheel, correct safety belt position and correct head restraint adjustment (general example).

The correct seating positions for the driver and passengers are specified in the information that follows. The safety belt and airbags only provide the optimum protection when vehicle occupants are seated in a correct seating position.

If you have a physical impairment that prevents you from sitting correctly on the driver seat with a correctly worn safety belt and reaching the pedals, special modifications to your vehicle may be necessary. For information on possible changes to your vehicle, contact an authorized Volkswagen dealer or authorized Volkswagen Service Facility qualified for this. Volkswagen recommends contacting an authorized Volkswagen dealer or authorized Volkswagen Service Facility. Alternatively, contact the Volkswagen Customer CARE Center at +00 (1) 800 822 8987.

For your safety and to reduce the risk of injuries in the event of a sudden braking maneuver or accident, Volkswagen recommends the following seating positions:

The following applies to all vehicle occupants:

- Adjust the head restraint so that the upper edge of the head restraint is in line with the upper portion of the head as much as possible, but not lower than eye level. Position the back of the head as close as possible to the head restraint *fig. 14*.
- For shorter individuals, slide the head restraint all the way downward, even if the head is then below the upper edge of the head restraint.
- For taller individuals, move the head restraint upward all the way.
- Keep both feet in the footwell while driving.
- Adjust and fasten the safety belts correctly ⇒ *Safety belts*.

The following additional points apply to the driver:

- Adjust the forward/back position of the driver seat so that you can press the pedals while your legs are slightly bent and there is at least 10 cm (around 4 inches) of space between the instrument panel and your knees *fig. 14*.
- Adjust the driver seat so that the top point of the steering wheel can be reached.
- Position the seat backrest in an upright position, so that your back rests completely on the seat backrest.
- Adjust the steering wheel so that the distance between the steering wheel and your chest is at least 25 cm (around 10 inches) *fig. 14* and you can hold the steering wheel firmly at the sides with both hands and your elbows slightly bent.
- When adjusted, the steering wheel must always face your chest and not be directed toward your face.
- In vehicles with head restraints that can be moved forward or back, position the head restraint so that it is as close as possible to the back of the head.
- Always keep both feet in the footwell to keep control of the vehicle at all times.

The following additional points apply to the front passenger:

- In vehicles with head restraints that can be moved forward or back, position the head restraint so that it is as close as possible to the back of the head.
- Position the seat backrest in an upright position, so that your back rests completely on the seat backrest.
- Move the front passenger seat into the rear half of the adjustment range so that the airbag can provide optimum protection if it deploys.

Safety belts

Introduction

Check the condition of all of the safety belts regularly. If there is damage to the belt fabric, the belt connections, the automatic safety belt retractor or the buckle, have the affected safety belt replaced immediately by suitably qualified professionals ⇒ . The authorized Volkswagen dealer or authorized Volkswagen Service Facility must use the correct parts for the vehicle, equipment and model year. Volkswagen recommends contacting an authorized Volkswagen dealer or authorized Volkswagen Service Facility.

WARNING

The risk of serious and fatal injuries increases if the safety belts are not worn or are worn incorrectly.

- Safety belts are the most effective way to reduce the risk of serious and fatal injuries in a collision. Before every trip, vehicle occupants must therefore seat themselves correctly, fasten the safety belt that belongs to the seat they are using, and keep it fastened while the vehicle is in motion. This applies to all passengers and at all times, including during city driving.

- Secure only one person with a safety belt.
- Secure children in the vehicle with a child restraint that is appropriate for their weight and height and with the safety belt used correctly ⇒ *Transporting children safely*.
- Never allow children or infants to ride on anyone's lap and never strap children or infants to another person with the same safety belt.
- Only ever insert and latch the buckle tongue in the belt buckle for the corresponding seat. Using a buckle from another seat reduces the protection provided by the safety belt and can cause serious injuries.
- Do not wear extremely bulky, loose clothing in the vehicle, such as a coat over a sports jacket, because this could impair the fit and function of the safety belt.

⚠ WARNING

If the belt webbing or other parts of the safety belts are damaged, the safety belts could tear during a collision or sudden braking maneuver and cause serious or fatal injuries.

- Never damage the safety belts by trapping them or chafing them on sharp edges.
- Have damaged safety belts replaced immediately with new safety belts that are approved for the vehicle by Volkswagen. Safety belts that are stretched during a collision must be replaced by an authorized Volkswagen dealer or authorized Volkswagen Service Facility. Volkswagen recommends contacting an authorized Volkswagen dealer or authorized Volkswagen Service Facility. It may be necessary to replace them even if there is no visible damage. Check the safety belts' anchorage points as well.
- Never try to repair, modify, or remove the safety belts yourself. Have all repairs to safety belts, belt retractors and buckle components performed only by an authorized Volkswagen dealer or authorized Volkswagen Service Facility. Volkswagen recommends contacting an authorized Volkswagen dealer or authorized Volkswagen Service Facility.

Fasten seat belts reminder

📖 Please read the introductory information and heed the Warnings and Notice ⇒ ⚠ *Introduction*.



Fig. 15 In the instrument cluster display: warning light for the fasten seat belts reminder.

Fasten safety belts reminder for the front seats

 The driver or front passenger has not fastened their safety belt. Fasten all safety belts.

When the ignition is switched on, several warning and indicator lamps light up temporarily as a function check. They then turn off after a few seconds.

A chime also sounds.

When the ignition is switched on, the red  warning light comes on for six seconds. A chime also sounds for up to six seconds if the driver safety belt is not fastened. The chime ends when the driver fastens their safety belt. The warning lamps and chime go off when the driver and front passenger have fastened their safety belts.

If the driver and front passenger do not both fasten their safety belts within 10 seconds after the chime has ended and the vehicle is driving at a speed above 8 km/h (5 mph), the chime will sound for 92 seconds. The red  warning light in the instrument cluster display will also blink.



When the ignition is switched on, the red  warning light comes on until the driver and front passenger have both fastened their safety belts.

Safety belt status indicator for the rear seats (depending on the country and the vehicle equipment)



When the ignition is switched on, the safety belt status indicator for the rear seats in the instrument cluster display shows the driver whether possible adult passengers in the rear seats have their safety belts fastened.

This indicator will look different, depending on which version of the instrument cluster you have.



Option 1

 When the symbol is green, this indicates that the passenger in this seat has fastened “their own” safety belt.  When the symbol is red, this indicates that the passenger in this seat has no longer has “their own” safety belt fastened.  This white symbol indicates that this seat is not occupied or that the passenger has not fastened “their own” safety belt.

Option 2

 This symbol indicates that the passenger in this seat has fastened “their own” safety belt.  This symbol indicates that this seat is not occupied or that the passenger has not fastened “their own” safety belt.

Fasten seat belts reminder for the rear seats (depending on the country and the vehicle equipment)



If a rear seat safety belt is unfastened during the journey, the red or white symbol for that seat  comes on, depending on the variant. The red  warning light in the instrument cluster display will also blink. If driving at speeds faster than approx. 8 km/h (approx. 5 mph), a warning chime will also sound for 92 seconds.

WARNING

The fasten seat belts reminder is designed to recognize adult vehicle occupants. A seat occupied by a light person, particularly by children, may not necessarily be recognized. The fasten seat belts reminder does not react, or has limited reactions when a child seat or seat cushion is in use. This may result in failure to detect that lighter people and children do not have their safety belt fastened. They could suffer serious or fatal injuries in an accident.

- Always ensure that all vehicle occupants, especially children, have their seat belt correctly fastened.

Using safety belts

 Please read the introductory information and heed the Warnings and Notice  [Introduction](#).

Checklist

Using safety belts :

- ✓ Check the condition of all of the safety belts regularly.
- ✓ Keep safety belts clean.

- ✓ Always keep foreign objects and fluids far away from the safety belt, the safety belt buckle, and the slot in the safety belt buckle.
- ✓ Do not pinch or damage the safety belt and/or belt buckle, for example closing it in a door.
- ✓ Never remove, modify, or repair the safety belt and belt fastening elements.
- ✓ Always fasten the safety belt correctly before you begin driving and keep it fastened while driving.

Twisted safety belt

If the safety belt is difficult to pull out of the belt guide, the safety belt may have been pulled out too quickly when positioning the belt and may have become twisted within the side trim panel:

1. Slowly and carefully pull the safety belt out completely by the belt buckle.
2. Untwist the safety belt and guide the safety belt back slowly by hand.

If you cannot untwist the safety belt, fasten the safety belt anyway. The twist must not be in a belt area that lies directly against the body. Contact an authorized Volkswagen dealer or authorized Volkswagen Service Facility immediately to have the twist rectified. Volkswagen recommends contacting an authorized Volkswagen dealer or authorized Volkswagen Service Facility.

Lockable safety belt

The safety belts on the rear seats and the safety belt on the front passenger seat are lockable and have an emergency locking function. With the locking function, you can adjust the safety belt so that a child restraint is properly installed ⇒ [Securing a child restraint with a safety belt](#).

Safety belts may only be locked for certain child restraint systems ⇒ [Child restraints – overview](#).



An activated locking mechanism must be released when a vehicle occupant fastens their safety belt. To release the lock, push the red button in the belt buckle and guide the seat belt back fully by hand.

WARNING

Incorrect handling of the safety belts increases the risk of severe or fatal injuries.

- Check the safety belts and associated components regularly to ensure they function correctly.
- Never attempt to repair safety belts. Have damaged safety belts replaced.
- Always keep the safety belts clean.
- Never damage the safety belts by trapping them or chafing them on sharp edges.
- Always keep the belt buckle and insertion guide for the belt buckle free of foreign objects and fluids.

Fastening and unfastening the safety belts

 Please read the introductory information and heed the Warnings and Notice ⇒  [Introduction](#).

Safety belts that are fastened correctly hold vehicle occupants in the correct position during braking maneuvers or in a collision, in order to provide the maximum protection ⇒ .

Fastening the safety belt



Fig. 16 Inserting the buckle tongue into the safety belt buckle (general example).

Always fasten the safety belts before driving.

1. Adjust the front seat and head restraint correctly ⇒ *Seating position*.
2. Have the rear seat backrest locked into place in an upright position ⇒ ⚠.
3. Grab the belt and pull it evenly over the chest and pelvis. Do not twist the belt while doing this ⇒ ⚠.
4. Insert the buckle tongue securely in the safety belt buckle for that seat *fig. 16*.
5. Pull on the safety belt to make sure the buckle tongue is latched correctly in the safety belt buckle.

Unfastening the safety belt



Fig. 17 Releasing the buckle tongue from the safety belt buckle (general example).

Only unfasten the safety belt while the vehicle is stationary ⇒ ⚠.

1. Press the red button in the safety belt buckle *fig. 17*.

The buckle tongue will pop out.

2. Guide the belt back by hand so that the belt rolls up easily, the belt does not twist, and the trim panel is not damaged.

⚠ WARNING

Incorrect safety belt positioning or unfastening the safety belt while the vehicle is in motion can lead to serious or fatal injuries in the event of an accident or braking maneuver.

- Place the backrest in an upright position and position your safety belt correctly for your size to maximize the protective function of the safety belt.
- Never unfasten the safety belt while the vehicle is in motion.

Safety belt positioning

📖 Please read the introductory information and heed the Warnings and Notice ⇒ ⚠ *Introduction*.

Safety belts only offer the optimum protection during a collision and reduce the risk of serious injury or death if they are fastened and positioned correctly. The correct safety belt position also holds the vehicle occupant in place so that the airbags can provide their maximum protection if they deploy. Therefore, all vehicle occupants should always fasten their own safety belts and make sure they are positioned correctly *fig. 18*.

An incorrect seating position can cause severe or fatal injuries ⇒ *Seating position*.

Correct safety belt positioning

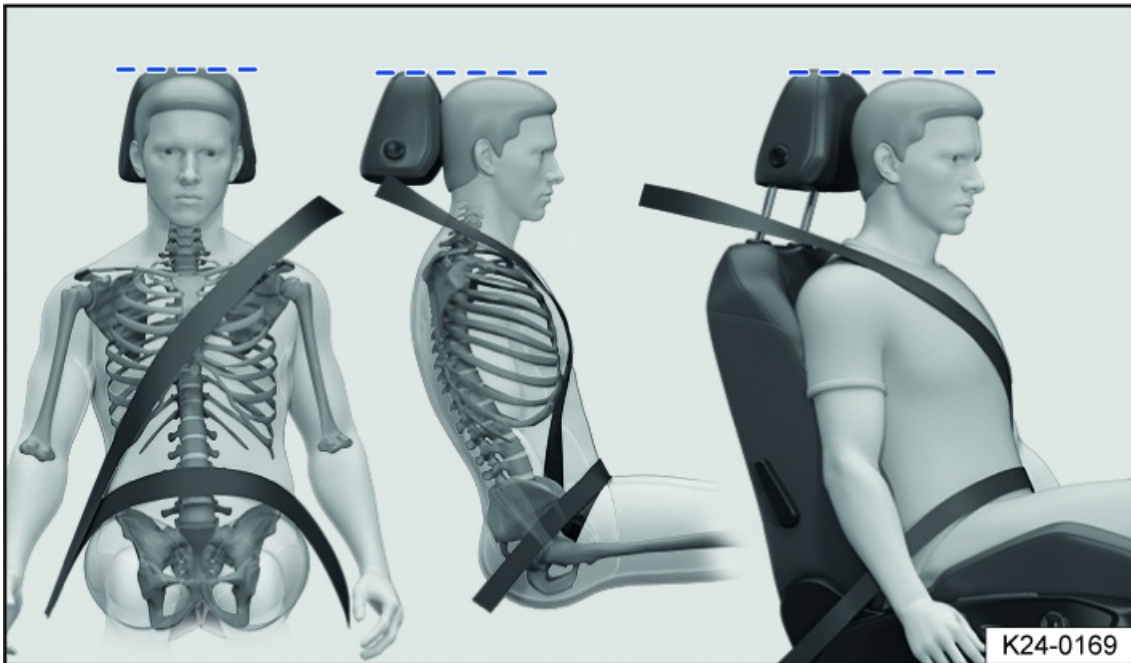

Fig. 18 Correct safety belt positioning and correct head restraint adjustment (general example).

- The shoulder belt section of the safety belt must always be positioned over the center of the shoulder and never across the neck, above the arm, under the arm, or behind the back.
- The lap section of the safety belt must always lie across the lap and never over the stomach.
- The safety belt must always rest flat and securely on the body. Retighten the belt if necessary.

Correct safety belt positioning for pregnant women



Fig. 19 Correct safety belt positioning for pregnant women (general example).

For pregnant women, the safety belt must rest evenly across the chest and as low and flat as possible on the lap, so that no pressure is applied to the lower abdomen. This should be done throughout the entire pregnancy [fig. 19](#).

Adjusting the safety belt position to body size

The belt positioning can be adjusted with the following equipment:

- Belt height adjusters for the front seats ⇒ *Safety belt height adjuster*.
- Height-adjustable front seats ⇒ *Seating position*.

WARNING

Incorrect safety belt positioning can cause serious injuries in the event of an accident or during sudden braking or driving maneuvers.

- Ensure your safety belt is positioned correctly.
- Place the backrest in an upright position and position your safety belt correctly for your size to maximize the protective function of the safety belt.
- Place the shoulder portion of the safety belt over the center of your shoulder, and never under your arm or across your neck.
- Lay the safety belt flat and securely on the upper part of the body and pelvis. Retighten the belt if necessary.
- Ensure the lap section of the safety belt lies across your lap and never over your stomach.
- Throughout your pregnancy, ensure the safety belt rests evenly across your chest and as low and flat as possible on your lap. This will prevent pressure being applied to your lower abdomen.
- Do not twist the safety belt while wearing it.
- Never hold the safety belt away from the body with your hand.
- Do not guide the safety belt over hard or breakable objects, such as eyeglasses, pens, or keys.
- Do not modify how the safety belt is routed using belt clips, retaining loops, or similar objects.

 Persons who cannot achieve the optimum belt routing due to physical conditions should contact an authorized Volkswagen dealer or authorized Volkswagen Service Facility about possible special modifications that can be used to achieve the best possible protection with the safety belt and airbags. Volkswagen recommends contacting an authorized Volkswagen dealer or authorized Volkswagen Service Facility.

Safety belt height adjuster



 Please read the introductory information and heed the Warnings and Notice ⇒  *Introduction*.



Fig. 20 Next to the front seats: safety belt height adjuster.

You can use the safety belt height adjuster to adjust the safety belt routing in the shoulder area according to your individual body size, so that the safety belt can be correctly fastened:



1. Push down and hold the safety belt height adjustment button in the direction of the arrows *fig. 20*.
2. Slide the safety belt height adjuster upward or downward until the safety belt lies over the center of the shoulder ⇒ *Safe belt positioning*.
3. Release the safety belt height adjustment button.
4. Pull hard on the safety belt to check that the safety belt height adjuster is engaged.

WARNING

Changing the safety belt height while driving may cause serious or fatal injuries.

- Never adjust the safety belt height while driving.

Automatic safety belt retractor, safety belt pretensioner, safety belt load limiter

 Please read the introductory information and heed the Warnings and Notice ⇒  *Introduction*.

The vehicle seat belts are part of the vehicle safety concept ⇒ *Airbag system*. The vehicle safety concept has the following key functions:

Automatic safety belt retractor

Every safety belt is equipped with an automatic safety belt retractor on the shoulder belt section. If the safety belt is pulled slowly or while driving normally, the shoulder belt will be able to move freely. The automatic safety belt retractor blocks the safety belt from moving if the safety belt is pulled out quickly, for example during sudden braking maneuvers, when driving on hills, when driving around curves and when accelerating.

Safety belt pretensioners

The safety belts for the driver and front seat passenger are equipped with safety belt pretensioners.

Safety belt pretensioners are activated by sensors and tighten the safety belts in the event of severe front-on, side and rear collisions or if the vehicle rolls over. If the safety belt is loose, it retracts. This can reduce the forward movement of the vehicle occupants and movement of the vehicle occupants in the direction of the collision. The safety belt pretensioner works together with the airbag system. The safety belt pretensioner is only activated during a rollover accident if the Side Curtain Protection® airbags are deployed.

Fine dust may appear if airbags deploy. This is completely normal and does not indicate a fire in the vehicle.

WARNING

The safety belt pretensioners only provide protection for one deployment. If the safety belt pretensioners deploy, the system must be replaced.



- Have deployed safety belt pretensioners and affected system components replaced immediately with new parts that are approved by Volkswagen for the vehicle.
- Only have suitably qualified professionals make repairs or modifications to a vehicle. Authorized Volkswagen dealers and authorized Volkswagen Service Facilities have the required tools, diagnostic devices, repair information, and qualified personnel. Volkswagen recommends contacting an authorized Volkswagen dealer or authorized Volkswagen Service Facility.
- Never install safety belt pretensioner components removed from scrap vehicles or from recycling.
- Never modify any components of the safety belt pretensioners.

Safety belt load limiter

Safety belt load limiters reduce the force placed on the body by the safety belts during a collision.

 When disposing of the vehicle or of individual system components, all safety precautions must be observed. An authorized Volkswagen dealer or authorized Volkswagen Service Facility will be familiar with these provisions ⇒ [Safety belt pretensioner servicing and disposal](#). Volkswagen recommends contacting an authorized Volkswagen dealer or authorized Volkswagen Service Facility.

Safety belt pretensioner servicing and disposal

 Please read the introductory information and heed the Warnings and Notice ⇒  [Introduction](#).

When working on safety belt pretensioners, as well as when removing and installing other vehicle components as part of repair work, the safety belts can become damaged without you noticing. This may cause the safety belt pretensioner to not work correctly or prevent it from working in the event of an accident.

The instructions must be followed so that the effectiveness of the safety belt pretensioner is not impaired and removed components do not cause injuries and environmental pollution. An authorized Volkswagen dealer or authorized Volkswagen Service Facility will be familiar with these provisions. Volkswagen recommends contacting an authorized Volkswagen dealer or authorized Volkswagen Service Facility.

WARNING

Repairs that you perform yourself or that are performed incorrectly on the safety belts, automatic safety belt retractors, and safety belt pretensioners can increase the risk of severe or fatal injuries. The safety belt pretensioner may not deploy when it should, or it may deploy unexpectedly.

- Never perform repairs, adjustments, or removal and installation of components of the safety belt pretensioners or safety belts yourself. Only have these procedures performed by suitably qualified professionals ⇒ [Accessories, replacement parts, repairs, and modifications](#). Volkswagen recommends contacting an authorized Volkswagen dealer or authorized Volkswagen Service Facility.

- Safety belts, safety belt pretensioners and automatic safety belt retractors cannot be repaired. These components must be replaced.

 Some parts of the vehicle, such as the airbag module and safety belt pretensioners, may contain perchlorate. Special handling may be required. For further information, visit <https://dtsc.ca.gov/perchlorate>.

Airbag system

Introduction

Airbags are not a replacement for safety belts, which must always be worn.

Airbags can only provide additional protection for vehicle occupants if the seats, safety belts, head restraints and steering wheel for the driver are adjusted correctly and used.

Never rely solely on the airbag system. The airbags only provide a supporting safety function.

The airbag system is part of the entire passive vehicle safety concept. The airbag system can only provide the best possible protection when it works in conjunction with safety belts that are fastened correctly and a correct seating position  ⇒ *Seating position*, ⇒ *Safety belts*.

The airbags will not deploy in all situations where there is visible vehicle damage.

Situations in which airbags will not always deploy:

- If the ignition is switched off during a collision.
- In minor head-on collisions.
- In non-serious side-on collisions.
- In rear-end collisions.
- If the speed of rotation measured by the control module is too low during a rollover.
- In low-speed collisions.
- Applies to front passenger's front airbag: If the passenger seat recognition system recognizes that the front passenger seat is unoccupied and the PASSENGER AIR BAG **OFF** ₂ indicator light comes on.

The airbag cannot always prevent injuries, such as swelling, bruises, burns, and abrasions.

WARNING

If there are objects located between vehicle occupants and the airbag deployment zone, they will change the airbag deployment zone and the risk of injury if the airbag deploys increases. During sudden braking or driving maneuvers or in the event of an accident, the objects could move into the airbag deployment zone and then be thrown through the vehicle interior if the airbag deploys.

- Never hold objects in your hands or on your lap while driving.
- Never transport objects on the front passenger's seat.

WARNING

Once the airbags have been deployed, they lose their protective function and must be replaced. If the airbags do not have their protective function, the risk of injury during sudden braking or driving maneuvers or accidents increases.

- Have any deployed safety airbags and affected system components replaced immediately with new parts that are

approved by Volkswagen for the vehicle.

- Only have suitably qualified professionals make repairs or modifications to a vehicle. Authorized Volkswagen dealers and authorized Volkswagen Service Facilities have the required tools, diagnostic devices, repair information, and qualified personnel. Volkswagen recommends contacting an authorized Volkswagen dealer or authorized Volkswagen Service Facility.
- Never install airbag components removed from scrap vehicles or from recycling.
- Never modify components of the airbag system.

WARNING

Fine dust and water vapor can develop when the airbags deploy. This is normal and does not indicate a fire in the vehicle. The fine dust can irritate the skin and mucous membranes in the eyes and can cause breathing problems, particularly for individuals who have asthma or other respiratory conditions.



- To reduce the risk of breathing problems, exit the vehicle or open the windows or doors for fresh air.
- If you come into contact with the dust, wash your hands and face with mild soap and water before eating anything.
- Flush your eyes and any open wounds with water if dust enters them.

WARNING

Cleaners that contain solvents can make the surface around the airbag installation locations porous. Plastic pieces that come loose could be thrown through the vehicle interior and cause serious injuries in the event of a collision with airbag deployment.

- Never treat the instrument panel and the surfaces around the airbag installation locations with cleaners that contain solvents.

Advanced Airbag System

 Please read the introductory information and heed the Warnings and Notice ⇒  *Introduction*.
Read and follow the introductory information and safety precautions ⇒ *Safety notes on using child restraints*.

An active passenger's front airbag presents serious dangers for a child ⇒ . For this reason, all children under the age of 12 must be secured in the rear seats while the vehicle is in motion.

The Advanced Airbag System, together with the side and Side Curtain Protection® airbags, is checked every time the ignition is switched on. The yellow airbag indicator light  comes on briefly and turns off after several seconds.

DANGER

The front passenger seat of a vehicle is a potential danger to children (even for advanced airbags). In the event that the front passenger seat air bag is deployed, children who are completely unsecured in an unsecured child restraint or in a rear-facing child restraint on the front passenger seat will suffer serious or fatal injuries.

- Even if your vehicle is equipped with an Advanced Airbag System, make sure that children (particularly children younger than 12 years of age) are always transported in such a way that they are secured to the rear seats according to their age and size.

Indicator light for front passenger's front airbag

Meaning of the indicator light for front passenger's front airbag

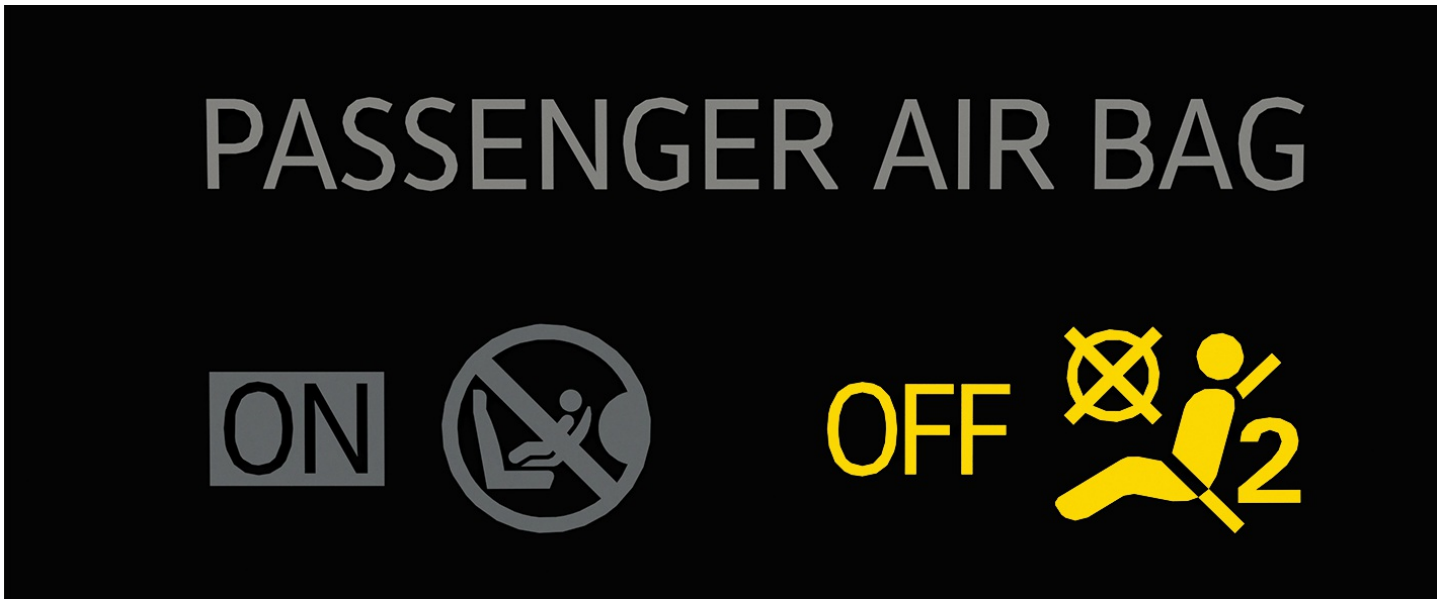

Fig. 21 In the roof console: indicator light for the switched off front passenger's front airbag.

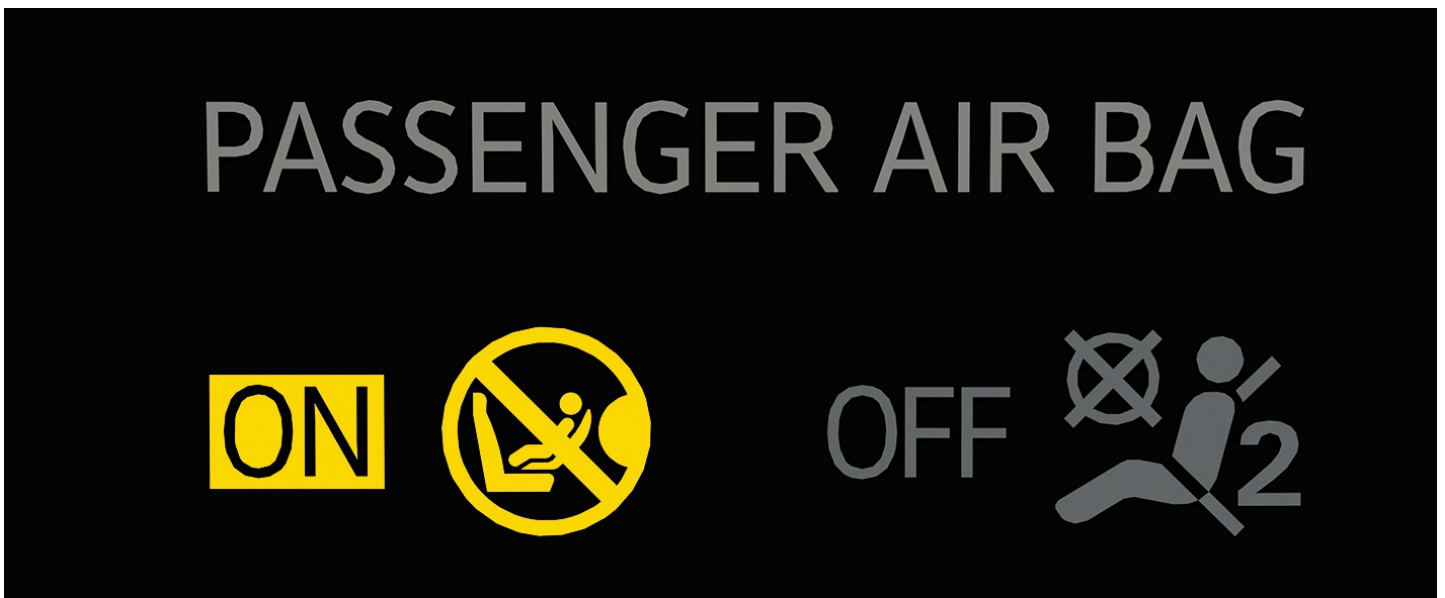





Fig. 22 In the roof console: Indicator light for the activated front passenger's front airbag.

The yellow PASSENGER AIR BAG indicator light **OFF**  *fig. 21* comes on as soon as the Advanced Airbag System has deactivated the front passenger airbag.

The yellow PASSENGER AIR BAG indicator light **ON**  *fig. 22* comes on as soon as the Advanced Airbag System has activated the front passenger airbag.

The yellow **OFF**  PASSENGER AIR BAG indicator light blinks for around five seconds in the following situations:

- The capacitive passenger detection system detects that the front passenger seat is not occupied.
- The capacitive passenger detection system detects a child restraint according to FMVSS 208 or CMVSS 208 ⇒ *Airbag system.*

The yellow **ON**  PASSENGER AIR BAG indicator light blinks for around five seconds when the capacitive passenger detection system has detected an adult occupying the seat. The yellow PASSENGER AIR BAG **ON**  indicator light then illuminates for about 60 seconds, or, depending on the vehicle equipment, it will remain illuminated.

Ensure that the status of the airbag (on or off) is shown correctly by the indicator light according to the load on the seat.

If the front passenger seat is not occupied, the front passenger's front airbag is also deactivated and the PASSENGER AIR BAG indicator light **OFF**  remains on.

Indicator light for the front passenger's front airbag when using a child restraint

The yellow PASSENGER AIR BAG indicator light **OFF**  must come on when the ignition is switched on and an infant carrier or child restraint is installed on the front passenger seat and the measured capacity is less than or equal to the capacity of an average one-year old child in a child restraint system as per FMVSS 208 or CMVSS 208.

Never install a rear-facing child restraint on the front passenger seat. The safest place for a child restraint is on the rear seat.

Under these conditions, the yellow PASSENGER AIR BAG indicator light **OFF**  must come on and stay on whenever the ignition is on. If this is not the case, stop the vehicle as soon as it is safe to do so and follow these instructions:

- Switch the ignition off for at least 4 seconds and then on again.
- Remove the child restraint from the front passenger seat and install it again according to the manufacturer's instructions. When doing so, ensure that the child restraint is installed correctly.
- Ensure that the safety belt has been guided around the child restraint correctly and that it is secure.
- Ensure that there are no electronic devices on the front passenger seat.
- Ensure that the safety belt and belt buckle are working correctly and not blocked.
- Ensure that no seat heating or similar systems have been retrofitted.
- Ensure that there are no damp objects on the front passenger seat.

If the yellow PASSENGER AIR BAG indicator light **OFF**  still does not come on, remove the child restraint immediately and install it on the rear seat. Visit an authorized Volkswagen dealer or authorized Volkswagen Service Facility as soon as possible to have the airbag system checked. Volkswagen recommends contacting an authorized Volkswagen dealer or authorized Volkswagen Service Facility.

Indicator light for the front passenger's front airbag with seat occupied by an adult

The yellow PASSENGER AIR BAG indicator light **OFF**  must not come on if the front passenger seat is occupied by an adult. However, if this is the case, stop the vehicle as soon as it is safe to do so and ensure the following:

- Ensure that the passenger is sitting in the middle of the seat and that the backrest is upright.
- Ensure that the belt is correctly positioned and tight.
- Ensure that there are no other objects on the seat cushion, such as blankets or booster seats, that could affect the system's ability to detect a passenger.



If the yellow PASSENGER AIR BAG indicator light **OFF**  is still permanently on, the passenger must move to the rear seat. Visit an authorized Volkswagen dealer or authorized Volkswagen Service Facility as soon as possible to have the airbag system checked. Volkswagen recommends contacting an authorized Volkswagen dealer or authorized Volkswagen Service Facility.

Troubleshooting

 Please read the introductory information and heed the Warnings and Notice ⇒  [Introduction](#).

Indicator light for front passenger's front airbag malfunction

The yellow indicator light stays on.

The yellow PASSENGER AIR BAG indicator light **OFF**  is malfunctioning and the status of the front passenger's front airbag is no longer correct. However, a faulty yellow PASSENGER AIR BAG indicator light **OFF**  does not mean that the front passenger's front airbag is malfunctioning.

1. Contact a suitably qualified professional to have the airbag system checked. Volkswagen recommends contacting an

authorized Volkswagen dealer or authorized Volkswagen Service Facility.

Airbag System or Safety Belt Pretensioner Malfunction

The yellow indicator light stays on. There may also be a message in the instrument cluster display.

A malfunction has been detected in at least one of the airbags or safety belt pretensioners.

1. Visit an authorized Volkswagen dealer or authorized Volkswagen Service Facility and have the airbag system and safety belt pretensioners checked. Volkswagen recommends contacting an authorized Volkswagen dealer or authorized Volkswagen Service Facility.

Airbag System or Safety Belt Pretensioner deactivated with Diagnostic Device

After the ignition is switched on, the yellow indicator light turns on for about four seconds and then blinks for about twelve seconds. There may also be a message in the instrument cluster display.

At least one airbag or safety belt pretensioner has been switched off by a diagnostic device.

1. Visit an authorized Volkswagen dealer or authorized Volkswagen Service Facility and have a check carried out as to whether the airbag system or safety belt pretensioners need to remain switched off. Volkswagen recommends contacting an authorized Volkswagen dealer or authorized Volkswagen Service Facility.

ON Front passenger's front airbag enabled

The yellow indicator light blinks for about 5 seconds when the capacitive passenger detection system has detected an adult occupying the seat or a child restraint. The yellow indicator light then illuminates for about 60 seconds, or, depending on the vehicle equipment, it will remain illuminated.

The front passenger's front airbag is switched on.

1. Ensure that the correct status of the airbag (on or off) is shown by the indicator light according to the load on the seat.
2. If the front passenger's front airbag is incorrectly switched off, there may be a malfunction in the airbag system. Contact a suitably qualified professional. Volkswagen recommends contacting an authorized Volkswagen dealer or authorized Volkswagen Service Facility.

OFF Front passenger's front airbag switched off

The yellow indicator light blinks for about 5 seconds when the capacitive passenger detection system has detected no adult occupying the seat or a child restraint.

The front passenger's front airbag is switched off.

1. Check whether the front passenger's front airbag has to be switched off.
2. If the front passenger's front airbag is incorrectly switched off, there may be a malfunction in the airbag system. Contact a suitably qualified professional. Volkswagen recommends contacting an authorized Volkswagen dealer or authorized Volkswagen Service Facility.

OFF Front passenger's front airbag switched off

The yellow indicator light stays on.

The front passenger's front airbag is switched off.

1. Check whether the front passenger's front airbag has to be switched off.
2. If the front passenger's front airbag is incorrectly switched off, there may be a malfunction in the airbag system. Contact a suitably qualified professional. Volkswagen recommends contacting an authorized Volkswagen dealer or authorized Volkswagen Service Facility.



If the status of the  indicator light is one of the following, the Advanced Airbag System must be checked by an authorized Volkswagen dealer or authorized Volkswagen Service Facility:

- The indicator light does not come on for several seconds when the ignition is switched on.
- The indicator light stays on after the ignition is switched on.
- The indicator light comes on or flashes again after it is turned off.
- The indicator light comes on while driving.

Components of the Advanced Airbag System

 Please read the introductory information and heed the Warnings and Notice  [Introduction](#).

The following components are essential parts of the Advanced Airbag System:

- Capacitive passenger detection system in the front passenger seat.
- Optimized safety belts with safety belt pretensioners and safety belt load limiters.
- Front airbags for the driver and front passenger.
- Airbag indicator light .
- PASSENGER AIR BAG **OFF**  indicator light
- PASSENGER AIR BAG **ON**  indicator light
- Control modules and sensors.

How the components of the Advanced Airbag System work together:

On the passenger's side, regardless of whether the safety belt is being used or not, the front passenger's front airbag is switched off if the electrical capacity measured by the capacitive front passenger detection system is smaller than the value saved in the control module. The front passenger's front airbag is also switched off if the measured capacity corresponds to the value for an infant of around one year old in a child restraint certified in accordance with the Federal Motor Vehicle Safety Standard 208.

The indicator light for the front passenger's front airbag lights up continuously to tell you that the Advanced Airbag System on the front passenger side has been deactivated.

WARNING

Airbags and safety belt pretensioners that do not function properly can cause serious or fatal injuries in the event of an accident.

- If the airbag indicator light turns on, have the system inspected by an authorized Volkswagen dealer or authorized Volkswagen Service Facility as soon as possible. Volkswagen recommends contacting an authorized Volkswagen dealer or authorized Volkswagen Service Facility.
- Ensure that installation is only carried out by certified specialists and only with original Volkswagen replacement parts. Volkswagen recommends contacting an authorized Volkswagen dealer or authorized Volkswagen Service Facility.
- Never use used or recycled airbags or parts in the Advanced Airbag System. Only use new parts.

WARNING

Damage to the front passenger seat may affect the function of the Advanced Airbag System and cause severe or fatal injuries.

- Have damaged components in the front passenger seat and the capacitive detection system replaced by

authorized specialists as soon as possible.



- Never remove the front passenger seat or components of the front passenger seat, such as seat surfaces, wires, lines or seat covers.
- Never damage the seat covers or the seat surface of the front passenger seat.
- Never use protective covers or seat surfaces on the front passenger seat as these affect the capacitive detection system.
- Never transport electronic or electrical objects on or under the front passenger seat as these affect the capacitive detection system.
- Never use blankets, cushions or similar items on the front passenger seat as these affect the capacitive detection system.
- Never install seat heating on the front passenger seat.
- Never replace the seat cover on the front passenger seat.

WARNING

If the front passenger seat becomes wet or damp, this can cause the Advanced Airbag System to malfunction.

- Allow the seat to dry as soon as possible and have it checked for damage by an authorized Volkswagen dealer or authorized Volkswagen Service Facility. Volkswagen recommends contacting an authorized Volkswagen dealer or authorized Volkswagen Service Facility.

Installation Locations and Deployment Zones

 Please read the introductory information and heed the Warnings and Notice ⇒  *Introduction*.

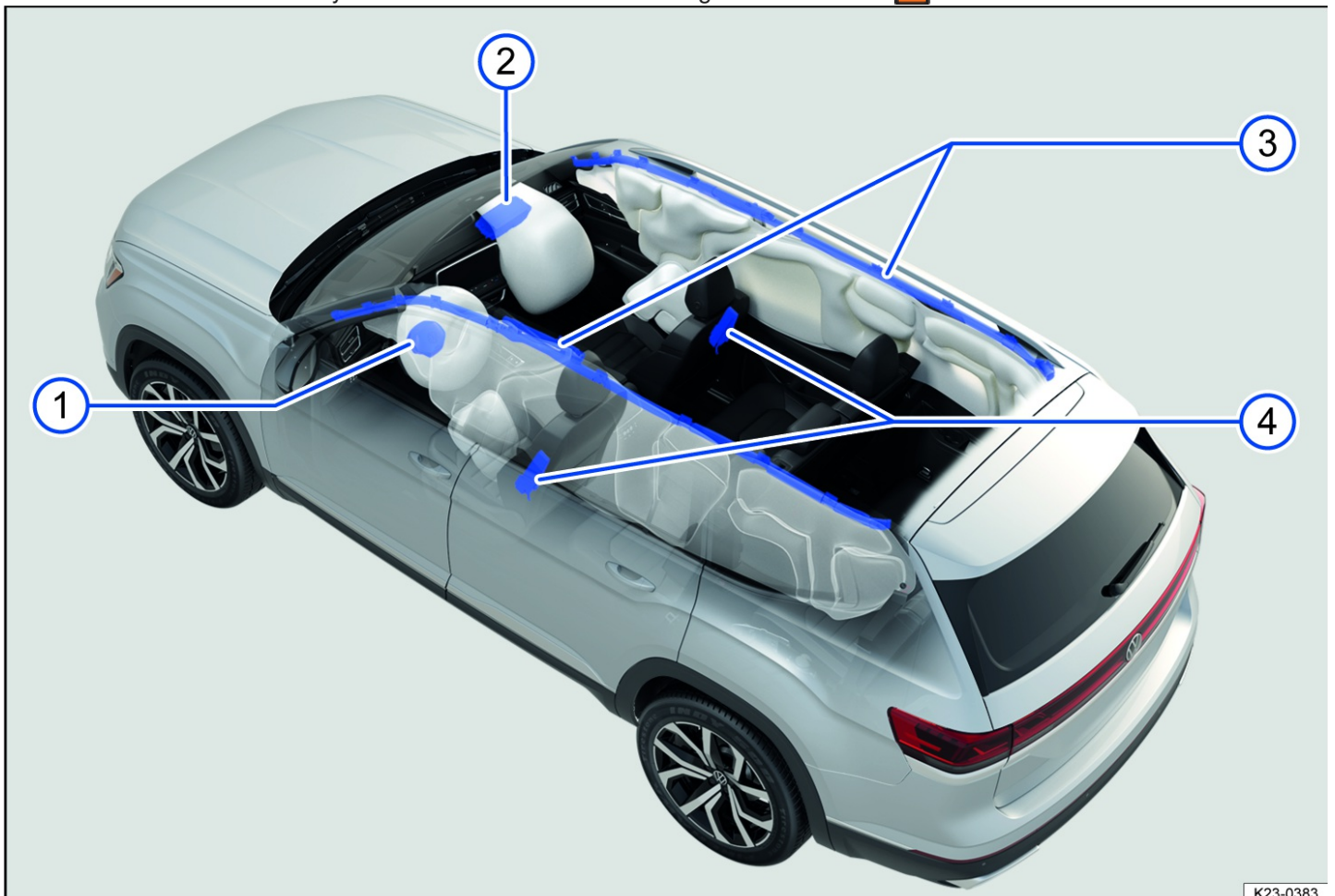

K23-0383

Fig. 23 Installation locations and deployment zones of the airbags.

Installation location

- ① Driver's front airbag in the steering wheel.
- ② Front passenger's front airbag in the instrument panel
- ③ Side Curtain Protection® airbags above the front and rear side windows (both sides).
- ④ Front side airbags in the driver seat and passenger seat backrests.

The airbag installation locations are indicated by the word "AIRBAG".

The white areas shown in the figure are accounted for by the airbags (deployment zone) *fig. 23*. Therefore, never place or attach objects in these areas *fig. 23*.

Side Curtain Protection airbags offer the "ejection mitigation" function, which protects the vehicle occupants and body parts from being completely or partially ejected from the vehicle in the event of a side impact collision or if the vehicle rolls over.

⚠ WARNING

An airbag deploys within a few milliseconds and at a very high speed. This could result in objects being thrown through the vehicle interior. This may cause serious injuries.

- Always keep the deployment zones of the airbags clear.
- Never attach objects to the covers or in the deployment zones of airbags.
- There should be no people, animals, or objects between the vehicle occupants and the airbag deployment zone. Make sure that children and other passengers also follow this instruction.
- Only hang lightweight clothing from the garment hooks in the vehicle. Never store heavy or sharp-edged objects in pockets.
- Do not attach any accessories to the doors.
- Do not attach any sunshades to the side windows that are not specifically approved for use in the vehicle.
- Only pivot sunshades toward the side windows if no objects such as pens or garage door openers are attached to the visor.

⚠ WARNING

An incorrect seating position may prevent the front airbag from functioning properly and cause serious injuries.

- Always hold the steering wheel with both hands on the sides of the outer edge, in the nine o'clock and three o'clock position.
- Adjust the driver seat so that there is a distance of at least 25 cm (10 inches) between your chest and the center of the steering wheel. If body characteristics mean that this is not possible, you must contact an authorized Volkswagen dealer or authorized Volkswagen Service Facility. Volkswagen recommends contacting an authorized Volkswagen dealer or authorized Volkswagen Service Facility.
- Adjust the front passenger seat so that there is the greatest possible distance between the front passenger and the instrument panel.

⚠ WARNING

Incorrect handling and use of the seats can inhibit the airbags from functioning correctly and cause serious injuries.

- Never remove the front seats from the vehicle or modify parts of them.
- Do not apply excessive force to the backrest bolsters.
- Only use seat covers or protective covers that are specifically approved for use in your vehicle.
- Have any damage to the seat covers or the seam in the airbag areas repaired immediately by suitably qualified professionals. Volkswagen recommends contacting an authorized Volkswagen dealer or authorized Volkswagen Service Facility.

WARNING

An incorrect seating position may prevent the knee airbag from functioning properly and cause serious injuries.

- Push the driver and front passenger seats far enough back such that there is at least 10 cm (approximately 4 inches) of space between the knees and the installation location of the knee airbag. If body characteristics mean that this is not possible, you must contact an authorized Volkswagen dealer or authorized Volkswagen Service Facility. Volkswagen recommends contacting an authorized Volkswagen dealer or authorized Volkswagen Service Facility.

Transporting children safely

Introduction

The physical principles in the event of an accident also apply to children. However, due to their size and other factors, children face a greater risk of injury.

Children and babies must therefore always be transported in child restraint systems that are designed for their age, size, weight and body structure. In the USA and Canada, the use of tested and certified child restraint systems is required by law.

In the case of head-on collisions at speeds of between 30 and 55 km/h (approx. 20 to 35 mph), a small child weighing 6 kg (13 lbs) will be subjected to forces of more than 20 times their body weight. This means that the child's effective weight will suddenly increase to up to 120 kg (260 lbs). Under such conditions, only a child restraint used in accordance with regulations can reduce the risk of injury. However, a child restraint which is not used in accordance with regulations may further increase the risk of injury!

All children (particularly children under 12 years of age) should always be transported on the rear seats in appropriate child restraint systems. However, if you must use a child restraint on the front passenger seat in exceptional circumstances, always follow all the information and warnings available at ⇒  [Introduction](#).

You can find more information on this subject at:

National Highway Traffic Safety Administration (NHTSA) (USA):

<http://www.safercar.gov>

Transport Canada Information Centre (Kanada):

<http://www.tc.gc.ca>

Read and follow the instructions from the child seat manufacturer to ensure that the seat is appropriate for your child. Also be sure to read and follow all the information and warnings on child restraint systems in this manual!

WARNING

Even though the Advanced Airbag System is designed to detect child restraint systems on the front passenger seat and to switch off the front passenger's front airbag, it is not possible to guarantee that the system will perform correctly under all circumstances and over the vehicle's service life. In the event of an accident, people sitting on the front passenger seat (particularly children and small children) may suffer serious injuries or death if there is insufficient distance between them

and the airbag when it is deployed (even with the Advanced Airbag System)!

- Always place children on the rear seats. This is the safest place for a child. A suitable child restraint that is installed on the rear seat in accordance with regulations provides the highest level of protection for children and small children in most accidents.
- In compliance with the “low risk” option for children of 3 to 6 years of age according to the U.S. Federal Standard, the Advanced Airbag System may be deployed if the electrical capacity of a typical one-year-old child combined with a child restraint system on the front passenger seat is exceeded and the criteria for deployment of the Advanced Airbag System are met.

⚠ WARNING

Accident statistics have shown that the rear seats offer greater safety than the front seats for children in general.

- Always transport children under 12 years of age on the rear seats.
- A child who is not secured or is not secured properly can be injured through sliding around in the vehicle interior or through being ejected from the vehicle during a sudden maneuver or collision. Secure children in the vehicle with a child restraint that is appropriate for their weight and height and with the safety belt used correctly ⇒ *Transporting children safely*.
- A child who is not secured or not properly secured is exposed to an increased risk of injury or death through collision with an airbag. Make sure that children are not within the deployment zone of the airbag.
- A child restraint system corresponding to body weight and body size that is installed and used on the rear seats offers maximum protection for infants and small children in most accident situations.

Child restraints – overview

📖 Please read the introductory information and heed the Warnings and Notice ⇒ **⚠ Introduction**.

All children (particularly small children and infants) must be transported in child restraints suitable for them. These child restraints must always be installed correctly. The information in the following table will help you to find the suitable child restraint for your child.

Child restraint type	Use
Rear-facing child restraint	<p>Birth to 12 months: A child up to 12 months old must always be transported in a rearward-facing child restraint. There are different types of these:</p> <ul style="list-style-type: none"> – Rear-facing child restraints only for infants. – Convertible and multi-purpose child restraints with higher weight and size restrictions to be able to transport your child for longer in the rear-facing position.
Rear-facing child restraint before the transition to a forward-facing child restraint	<p>1–3 years: Transport your child in a rear-facing child restraint for as long as possible until they have reached the weight and size restrictions. After your child has reached the weight and size restrictions, you can transport them in a forward-facing child restraint with the appropriate safety belts.</p>
Forward-facing child restraint	<p>4–7 years: Transport your child in a forward-facing child restraint for as long as possible until they have reached the weight and size restrictions. After your child has reached the weight and size restrictions, you can transport them in a booster seat but only on the rear seats.</p>

Child restraint type	Use
Booster seat	7–12 years: Transport your child in a booster seat until they are large enough to sit on the seat with the seat belt without a booster seat. The safety belt must be routed correctly ⇒ <i>Safety belt positioning</i> . You should continue to transport your child on the rear seats.

Child restraints can be fastened either with a three-point safety belt or with an ISOFIX/lower LATCH fastening system. Many child restraints also require the use of top tether systems. Depending on countries and federal states, the use of Top Tether may even be required by law.

How to determine whether a child restraint is installed correctly

- The child restraint sits flush with the seat cushion and the backrest, unless the manufacturer of the child restraint permits a gap between the seat and the child restraint.
- The overhang of the child restraint on the seat cushion is not longer than 20% of the child restraint. Always follow the instructions for the permitted child restraint overhangs.
- You should always position the child restraint centrally on the seat.
- The clearance of the child restraint forward and sideways is no greater than approximately 2.5 cm (1 inch).
- The child restraint must not rest on the belt buckles of the seats. These could be damaged as a result.
- When installing multiple child restraints, they must not block each other and must be free-standing and remain accessible.
- The child restraint has been secured correctly using the three-point safety belt or ISOFIX/lower LATCH anchorage point. The top tether system of the child restraint has also been used correctly as specified by the manufacturer.

DANGER

Children sitting on the front seats may suffer severe or fatal injuries in the event of airbag deployment (even if advanced airbags are used). Not using the child restraint, using it incorrectly or using the wrong child restraint increases the risk of severe injury or death in the event of an accident.

- Always install child restraints on the rear seats.
- If, in exceptional circumstances, you nevertheless install a child restraint on the front passenger seat and the yellow **OFF**  PASSENGER AIR BAG indicator light does not come on and stay on, remove the seat immediately and have the airbag system checked by an authorized Volkswagen dealer or authorized Volkswagen Service Facility. Volkswagen recommends contacting an authorized Volkswagen dealer or authorized Volkswagen Service Facility.

WARNING

If the airbag is deployed, a child restraint on the front passenger seat may collide with the airbag and the child in the child restraint may suffer severe or even fatal injuries (even if advanced airbags are used).

- If you nevertheless install a child restraint on the front passenger seat in exceptional circumstances, always ensure that the child restraint in use has been approved by the manufacturer for use on the front passenger seat.
- Read and always follow the child seat manufacturer's instructions.
- Never install a child restraint without the top tether safety belt if the use of a top tether safety belt is prescribed by the child restraint manufacturer or legally required for the child restraint.
- Never position a forward-facing child restraint directly against the instrument panel.

- Adjust the seat belt adjuster so that the seat can be installed correctly.
- Position the front passenger seat as high as possible and move it as far back as possible in order to obtain the largest possible distance to the instrument panel.
- Make sure that the upper anchorage of the safety belt is behind the child restraint to ensure that the safety belt is routed correctly.
- Make sure that the backrest is in the upright position.

⚠ WARNING

A child that is in a child restraint that has been secured with the anchor points or with a safety belt may play with any unused safety belts on the rear seat and get tangled up, which could result in serious or even fatal injuries.

- Always secure unused safety belts to the rear seat. You can do this by putting them around the head restraints which are furthest away from the installed child restraint and properly securing the safety belt.

! NOTICE

Improper use of the lockable safety belt can cause damage to the safety belt.

- Make sure that you do not activate the lockable belt system when you secure the safety belts that are not being used.
- Always ensure that you correctly and carefully install a child restraint with the safety belt.

Safety notes on using child restraints

📖 Please read the introductory information and heed the Warnings and Notice ⇒ ⚠ *Introduction.*



Fig. 24 Danger to infants not wearing safety belts.

The correct use of child restraints significantly reduces the risk of injury in the event of an accident or collision!

All children, in particular children under the age of 12, must always travel in suitable child restraints on the rear seat.

Only use child restraints that are suitable for the height and weight of the child.

ISOFIX/lower LATCH anchorage points can be used to secure child restraints on the seats without using the vehicle's safety belts. If, despite this, you want to install a child restraint with the safety belts instead of ISOFIX/lower LATCH anchorage points, follow all the instructions given by the child restraint manufacturer for the belt guide and for securing the child in the child restraint. Ensure that the child restraint cannot move forward or sideways by more than 2.5 cm (1 inch) after installation.

When installing a child restraint with the safety belt, you must activate the lockable belt system.

Never activate the lockable belt system when installing a booster seat or if a child is traveling without a child restraint.

Once the child restraint is correctly installed, the settings for that seat must no longer be changed. If the seat settings have been changed, the installation of the child restraint must be checked and, if necessary, adjusted.

If a child restraint is installed on a seat, functions such as the massage function ⇒ *Massage feature* or seat heating ⇒ *Using Seat Heating and Seat Ventilation* must not be used on that seat.

Important additional information for installing child restraints on the front passenger seat

If, under exceptional circumstances, you need to install a child restraint on the front passenger seat, read and follow all warnings and instructions here ⇒  *Introduction*.

You can find additional information on the selection and use of child restraints here:

Transport Canada Information Centre Tel.: 1-800-333-0371 Tel.: 1-613-998-8616 (Ottawa) <http://www.tc.gc.ca/roadsafety>

National Highway Traffic Safety Administration Tel.: 1-888-327-4236 (TTY: 1-800-424-9153) <http://www.nhtsa.gov> <http://www.safercar.gov>

National SAFE KIDS Campaign Tel.: 1-202-662-0600 <http://www.safekids.org>

SafetyBeltSafe U.S.A. Tel.: 1-800-745-SAFE or 1-800-745-7233 (English) Tel.: 1-800-747-SANO or 1-800-747-7266 (Spanish) <http://www.carseat.org>

Volkswagen Customer CARE Tel.: 1-800-822-8987

Advanced Airbag System, small children, child restraints and children on the front passenger seat

The Advanced Airbag System in your vehicle has been certified and complies with the regulations of the United States Federal Motor Vehicle Safety Standard (FMVSS) 208 and the Canada Motor Vehicle Safety Standard (CMVSS) 208 at the time of vehicle manufacture. In accordance with the requirements, the system on the passenger's side has been designed to "inhibit" deployment for small children of up to 12 months of age and "low-risk deployment" for children of between three and six years of age.

The airbag on the passenger's side is a potential danger for children when it is deployed. The front passenger seat is not the safest place for a child in a forward-facing child restraint and a very dangerous place for an infant or a child in a rear-facing child restraint.

The Advanced Airbag System has a capacitive detection system in the seat cushion of the front passenger seat which detects whether a baby, small child or child is in a child restraint on the front passenger seat.

The capacitive detection system measures the electrical capacity of a child, the child restraint and a child's blanket on the front passenger seat.

The electrical capacity of a child restraint depends on the child restraint type. Together with the average capacity values of small children and one-year-old children, the capacity values of all child restraints specified in accordance with FMVSS 213 and CMVSS 213 are stored in the Advanced Airbag System control module. These are compared with the values detected. Only use child restraints that are certified according to these standards and have been approved by the child restraint manufacturer for use with airbag systems. The U.S. National Highway Traffic Safety Administration (NHTSA) has published a list of certified child restraint models for use with the Advanced Airbag System in accordance with FMVSS 208.

Only install child restraints on the front passenger seat under exceptional circumstances. Carefully read all of the information

about child restraints and the Advanced Airbag System beforehand and follow all instructions and warnings. Make sure that the system has correctly detected the child restraint on the front passenger seat and the front passenger's front air bag has been switched off. The yellow **OFF**  PASSENGER AIR BAG indicator light will come on.

DANGER

The use of rear-facing child restraints or infant carriers on the front passenger seat can cause serious or fatal injury.

- Rear-facing child restraints or infant carriers must always be installed on the rear seats.

WARNING

Transporting children without a child restraint or with an unsuitable child restraint, or incorrectly installing a child restraint, increases the risk of severe injury or death in the event of an accident.



- Only use child restraints that are suitable for the child and that comply with the regulations set out by FMVSS 213 (CMVSS 213 in Canada).
- Only use child restraints that sit on the seat cushion of the vehicle.
- When installing the child restraint, follow the instructions given by the manufacturer of the child restraint.
- Always observe all legal requirements regarding the installation and use of child restraints.
- Children under 145 cm (around 4 ft, 9 inches) in size may only be secured and transported in the vehicle with an appropriate child restraint.
- Only one child must be allowed to travel in a child restraint.
- Never drive with children, toddlers or babies on your own lap or another passenger's lap.

WARNING

Forward-facing child restraints on the front passenger seat may collide with the airbag if it is triggered, which can lead to severe injury or death.

- Always install child restraints on the rear seat.

Securing systems

 Please read the introductory information and heed the Warnings and Notice ⇒  [Introduction](#). Different securing systems are used for safe installation of child restraints depending on the country.

Only use the securing systems described here to secure child restraints in the vehicle.

Overview of securing systems

- **ISOFIX/lower LATCH anchorage points** : ISOFIX/lower LATCH anchorage points are attachment systems for quick and secure attachment of child restraints in the vehicle. Attachment using ISOFIX/lower LATCH anchorage points creates a fixed connection between the child restraint and the vehicle.

The child restraint can have two fixed or flexible attachment arms. The attachment arms snap into the ISOFIX/lower LATCH anchorage points that are located between the seat cushion and the rear seat backrest ⇒ [Fastening a Child Restraint with ISOFIX or Lower LATCH Anchorage Point](#). Reinforce the attachment using the ISOFIX/lower LATCH anchorage points by attaching with a top tether safety belt or a support bracket, if necessary.

- **Three-point safety belt** : Child restraints can be fastened with a three-point safety belt ⇒ [Securing a child restraint with](#)

safety belt.

Additional fasteners:

- **Top Tether:** the upper belt is guided over the rear seat backrest and secured to the anchorage point on the rear side of the rear seats using a hook ⇒ *Securing the child restraint with the upper strap (top tether)* . Top tether anchorages are labeled with an anchor symbol.
- **Support base:** some child restraints are supported with a support base on the vehicle floor. The support base reduces the risk of the child restraint tipping forward in the event of a collision. Use child restraints with a support foot only on the front passenger seat and the outer rear seats in the second row of seats ⇒ ⚠.

⚠ WARNING

Incorrect use of the support base can cause serious or fatal injuries.

- Make sure the support base is installed correctly and securely.
- Always refer to and follow the installation instructions and warnings from the child restraint manufacturer.

Fastening a Child Restraint with ISOFIX or Lower LATCH Anchorage Point

📖 Please read the introductory information and heed the Warnings and Notice ⇒ ⚠ *Introduction*.

Installing child restraints with ISOFIX/lower LATCH anchorage point



Fig. 25 On the second-row rear seats: designation and symbol showing the ISOFIX/lower LATCH anchorage points for child restraints.



Fig. 26 Fitting a child restraint with arms (general example).

The installation location of the ISOFIX/lower LATCH anchorage points is indicated by a symbol [fig. 25](#).

1. Pay attention to and follow the information → page , *Safety notes on using child restraints*.
2. If necessary, fold down the protective caps of the ISOFIX/lower LATCH anchorage points.
3. Push the attachment arms of the child restraint in the direction of the arrow onto the ISOFIX/lower LATCH anchorage points [fig. 26](#). The child restraint must engage securely and audibly.
4. Pull on both sides of the child restraint to check that the child restraint is securely locked in place.

If the child restraint is equipped with a support foot, this support foot must be positioned securely on the vehicle floor.

Using insertion guides

If ISOFIX or lower LATCH anchorage points for child restraints are not directly accessible, the installation and removal of child restraints can be made easier through the use of guidance fixtures. For this, first attach the guidance fixtures to the ISOFIX or lower LATCH anchorage points. Then fasten the child restraint according to the installation instructions.

⚠ NOTICE

Guidance fixtures can cause permanent marks or damage to seat covers and cushions.

- Always remove the guidance fixtures from the ISOFIX/lower LATCH anchorage points before you fold the rear seats forward or remove the child restraint.

Securing the child restraint with the upper strap (top tether)

📖 Please read the introductory information and heed the Warnings and Notice ⇒ ⚠ *Introduction*.

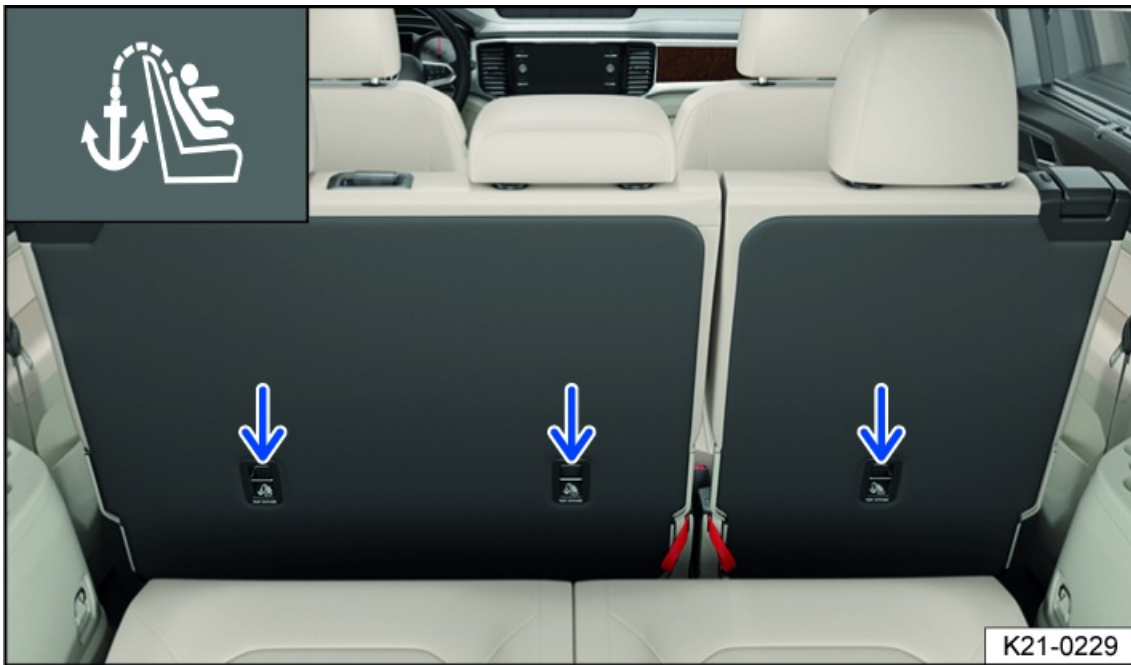

Fig. 27 On the back of the rear seats of the second-row seats: top tether anchorages for the top tether safety belt.



Fig. 28 On the back of the rear seats of the third-row seats: top tether anchorages for the top tether safety belt.

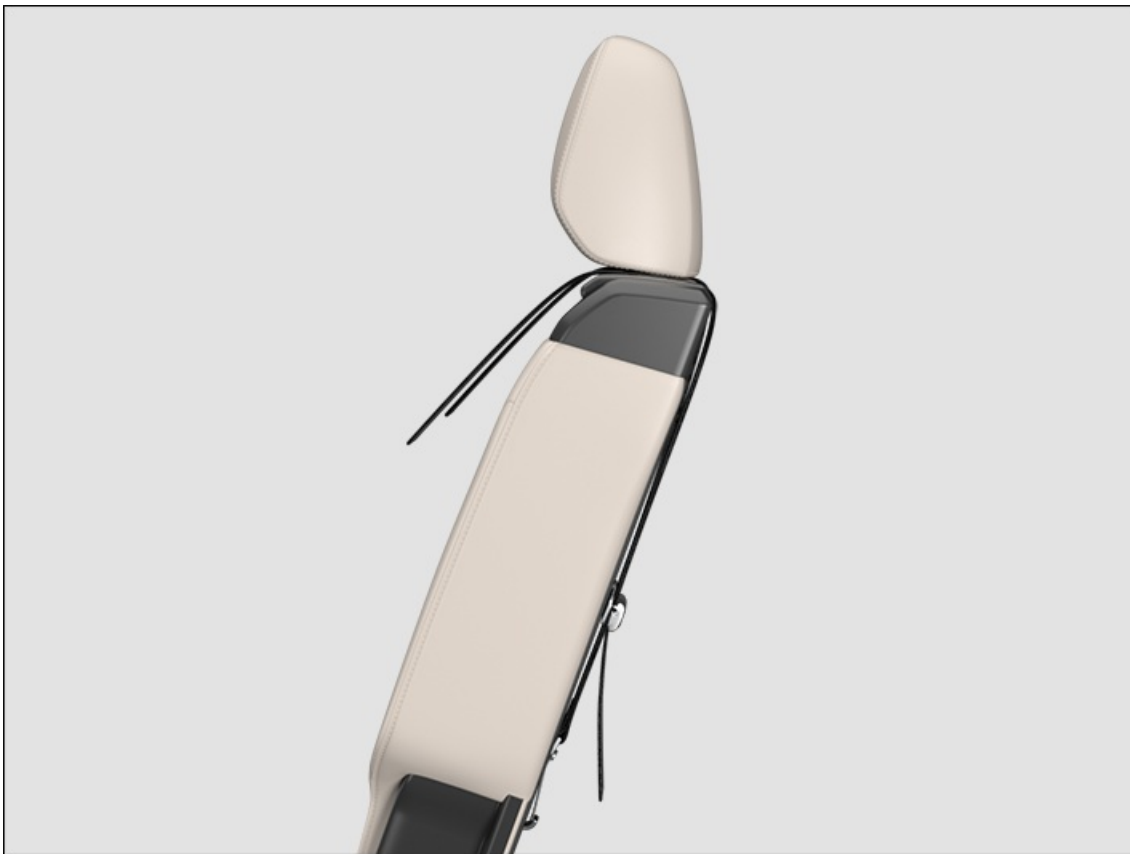

Fig. 29 On the back of the rear seats of the second or third-row seats: attached top tether safety belt.

Top tether safety belts reduce the forward movement of the child restraint during an accident. This reduces the risk of a head injury to the child.

The anchorages suitable for top tether are labeled with a symbol and may have the label “TOP TETHER” *fig. 27, fig. 28*. Fasten the top tether safety belt only to the top tether anchorages designed for this purpose.

Fastening the top tether safety belt

1. Pay attention to and follow the information → page , *Safety notes on using child restraints*.
2. Prepare the top tether safety belt on the child restraint according to the child restraint manufacturer instructions ⇒ ⚠.
3. If necessary, remove the luggage compartment cover and screen separator.
4. Place the child restraint in the center of the vehicle seat cushion and fasten it securely according to the child restraint manufacturer instructions.
5. If necessary, move the rear seat backrest of the vehicle seat to an upright position and adjust to the backrest of the child restraint.
6. Locate the top tether anchorage for the respective seat *fig. 27, fig. 28*.
7. If necessary, push the head restraint upwards and guide the top tether safety belt of the child restraint to the rear under the head restraint.

Applies to child restraints with a V-shaped top tether safety belt: Check that the top tether safety belt is taut on the seat and is not redirected by the bars of the head restraint.

8. Guide the top tether safety belt of the child restraint back over the seat.
9. Hook the top tether safety belt into the appropriate anchorage marked with “top tether” *fig. 29*.
10. Pull on the top tether safety belt.
11. Check that the hook of the top tether safety belt is closed.
12. Tighten the top tether safety belt according to the child restraint manufacturer instructions ⇒ ⚠.

13. If necessary, guide the head restraint back into the starting position.

WARNING

Fastening the child restraint incorrectly increases the risk of serious and fatal injuries during an accident.

- Always follow the child restraint manufacturer instructions for fastening the child restraint in the vehicle.
- Never fasten a child restraint without the top tether safety belt if the use of a top tether safety belt is prescribed by the child restraint manufacturer or legally required for the child restraint.

For example, the use of a top tether safety belt in conjunction with a forward-facing child restraint is legally required in Canada.

- Improper fastening of the top tether safety belt can lead to serious injuries during an accident. The top tether anchorages are only approved for correctly installed child restraints.
- Always only fasten a top tether safety belt of a child restraint to a top tether anchorage.
- Never fasten a child restraint top tether safety belt to a tie-down.
- Never fasten a safety belt or another belt of the child restraint to a top tether anchorage.
- Never fasten luggage or other objects to a top tether anchorage.

Releasing the top tether safety belt

1. Release the top tether safety belt according to the child restraint manufacturer instructions.
2. Release the catch on the hook and release the top tether safety belt from the top tether anchorage.

Securing a child restraint with a safety belt

 Please read the introductory information and heed the Warnings and Notice ⇒  *Introduction*.

Locking the safety belt

If a child restraint is fastened with a safety belt, the safety belt must be locked. Note the instructions provided by the child restraint manufacturer.

If a safety belt is locked, the belt cannot unwind. A locked safety belt prevents the safety belt being released during the journey which can mean that the child restraint is no longer sufficiently secured.

1. Pay attention to and follow the information → page , *Safety notes on using child restraints*.
2. If available, adjust the height of the safety belt so that the belt webbing runs naturally along the child restraint without any sharp bends in the webbing.
3. Install the child restraint according to the guide from the child restraint manufacturer and ensure that the safety belt mean for the seat is used.
4. Insert the buckle tongue into the belt buckle belonging to the corresponding seat, until the buckle tongue latches into place.
5. Check that the safety belt is not twisted.
6. Check that the lap section of the safety belt is taut.
7. Completely pull out the shoulder belt section of the safety belt and then let it gently roll up.

While the safety belt is being rolled up, a clicking sound can be heard. Once the safety belt is locked, it cannot be further pulled out.

8. Press the child restraint into the seat and let the safety belt roll up further. If necessary, return the shoulder belt section of the safety belt to the automatic safety belt retractor by hand.

9. Pull the belt guide of the child restraint.

Check that the child restraint cannot move further than 2.5 cm (approx. 1 inch).

Releasing the locked safety belt

The lockable safety belt may only be used to fasten certain child restraint systems in the vehicle. An activated locking mechanism must be released when a vehicle occupant fastens their safety belt.

1. Release the safety belt from the belt buckle.
2. Remove the child restraint according to the instructions from the child restraint manufacturer.
3. Press the red button in the belt buckle and guide the safety belt back fully by hand.

The safety belt is no longer locked.

Keep any safety belts that are not being used out of the reach of children



Fig. 30 Securing unused safety belts (general example).

Secure any safety belts not being used to prevent a child from playing with the safety belt and getting caught in it. The procedure for securing a safety belt that is not being used depends on the seating position.

To secure a safety belt that is not being used for one of the outer seats:

1. Position the safety belt around the head restraint of the center seating position [fig. 30](#).
2. Make sure that the safety belt is out of range of any children so that children cannot touch it or play with it.
3. Make sure that the safety belt is not blocking the lower anchors.

If the anchor points are blocked, this may mean that you cannot install the child restraint properly in the anchor points.

4. Do not activate the lockable safety belt.

Otherwise, it is very difficult to retract the safety belt into its normal position. You should not hear any clicking noises when the safety belt is retracted.

To secure a safety belt that is not being used for the center seating position or a third row seat:

1. Insert the buckle tongue of the safety belt in the belt buckle belonging to the seat *fig. 30*.
2. Pull the shoulder strap on the safety belt out fully to activate the lockable safety belt. You should hear a clicking noise when the safety belt is rolled up again.
3. Let the safety belt roll up fully. Pull the safety belt to make sure that the lockable safety belt is activated and the safety belt is properly fastened and tightened so that the child cannot get hold of the belt or play with it.

If a child is secured on a seat in the second or third row, adapt the position in front of the child restraint to give the child enough space. For example, adjust the front passenger seat to the size of the child and the child directly behind them. Always pay attention to the correct seating position ⇒ *Seating position*.



If no child restraints are needed, move all the safety belts back into their normal storage positions so that the safety belts are available for normal use.

WARNING

A child that is in a child restraint that has been secured with the anchor points or with a safety belt may play with any unused safety belts on the rear seat and get tangled up, which could result in serious or even fatal injuries.

- Always keep any safety belts for the rear seats that are not being used out of the reach of children in child restraints.

Installing three child restraints on the second-row seats

 Please read the introductory information and heed the Warnings and Notice ⇒  *Introduction*.

With the right combination of child restraints, three child restraints can be installed side by side on the second-row seats. Because there are different types of child restraints with different measurements, all child restraints must be installed correctly during this type of installation. It is not possible to install three very wide child restraints next to each other.

Installing on the center seating position

When installing a child restraint on the center seating position, it is especially important to install correctly because this seating position is narrower than both of the outer seats. If the child restraint is wider than the seat surface, the belt buckle of the adjacent seating position may be covered and could then be damaged. When installing child seats, always ensure that all belt buckles are easily accessible.

- If nothing else is specified by the child restraint manufacturer, the child restraint must rest close against the backrest and seat surface and must not overlap seat surfaces.
- The child restraint must be installed straight and centered on the seating position, and it must not be able to move more than 2.5 cm (approx. 1 inch).
- The child restraint must not rest on the belt buckles.
- When installing multiple child restraints, the child restraints must not become caught on one another.

In some cases, even if a child restraint is installed correctly on the center seating position, it may cover the belt buckles and could then damage them and make the belt buckles unusable. This can occur if the child restraint slides on the seat surface while driving. Therefore, check the position of the child restraint regularly to ensure that the belt buckles are neither covered nor damaged.

Cap for belt buckles



Fig. 31 In the second-row seats: fitted protective cap for belt buckles (general example).



Fig. 32 In the second-row seats: removing the protective cap for belt buckles (general example).

In addition to using buckles correctly and checking them regularly for damage, a protective cap can also be installed on unused belt buckles to help protect them from damage. This cap can be obtained as a Volkswagen accessory at an authorized Volkswagen dealer or authorized Volkswagen Service Facility.

This cap should always be used when child restraints are installed on the center position.

1. Install the protective cap on the belt buckle before the child restraint is installed.

2. Position the protective cap on the belt buckle and press it down until you hear it click into place [fig. 31](#).
3. Pull on the protective cap to check that it is secure. The cap must not be able to loosen.

The belt buckle is now out of action.

4. To remove the protective cap, push the belt buckle tongue into the oblong slot of the cap.
5. Press the button underneath with the buckle tongue [fig. 32](#).

The cap will pop out.

Securing a booster seat with a safety belt

📖 Please read the introductory information and heed the Warnings and Notice ⇒ ⚠️ [Introduction](#).



[Fig. 33](#) Correctly fastened child on a booster seat (general example).

Children between the ages of around 8 and 12 are best protected when they travel on a booster seat that is suitable for their age and height.

The safety belts of the vehicle generally only fit children 145 cm (approx. 4 ft, 9 in) tall or taller. Booster seats ensure that children under this height can be correctly fastened using the safety belt.

- Never activate the lockable belt system when securing children on a booster seat with a belt.
- The upper area of the belt must always be positioned on the child's shoulder. Ensure that the belt does not rest on the child's face or neck.
- The lap belt must always run across the child's lap. It must never run across the child's stomach.

Children above 145 cm (approx. 4 ft, 9 inches) in size can generally be secured with the safety belt. Pay attention to the information at ⇒ [Safety belt positioning](#).

Your child no longer needs a booster seat if they are taller than 145 cm (approx. 4 ft, 9 in) and the following conditions are met:

- The child is seated with their back fully against the backrest.
- The child's knees bend over the edge of the seat.

- The child's feet sit fully flat on the vehicle floor.
- The child can comfortably stay in this position for the entire journey.

Children aged 12 or under must always travel on a rear seat.

WARNING

Not using or incorrectly using a booster seat or incorrectly fastening a safety belt can result in severe injury or death in the event of an accident.

- Always observe all instructions regarding the installation and use of child restraints and booster seats.
- If, under exceptional circumstances, you need to install a booster seat on the front passenger seat, ensure that the PASSENGER AIR BAG **OFF**  indicator light turns on and remains on.



In case of an emergency

Securing yourself and the vehicle

Follow all legal regulations regarding securing a vehicle during a breakdown. For example, in many countries you must switch on the emergency flashers and wear a reflective vest ⇒ [Emergency equipment](#).

Checklist of what to do in the event of a breakdown

For your own safety and the safety of your passengers, follow the points below in the order they are given:

1. Park your vehicle a safe distance from traffic and on suitable ground. Observe all important information on parking when doing so ⇒ , ⇒ [Parking](#).
2. Switch on the emergency flashers  ⇒ [Center console](#).
3. Have all vehicle occupants exit the vehicle on the side facing away from traffic and move to a safe area, such as behind a guard rail. Follow the local regulations regarding wearing a reflective vest.
4. Set up the warning triangle to warn others on the road about the vehicle.
5. Observe the safety instructions → page , [Safety precautions for working in the hood space](#) .
6. If necessary, contact an authorized Volkswagen dealer or authorized Volkswagen Service Facility for assistance. Volkswagen recommends contacting the Volkswagen emergency assistance service.

When the emergency flashers are switched on, for example while towing the vehicle, you can indicate any turns or lane changes using the turn signal lever. The emergency flashers will stop temporarily.

Read and observe the important information about towing ⇒  [Introduction](#).

WARNING

A stalled vehicle increases the risk of a crash that could cause injury to you, your vehicle occupants, or others on the road.

- Stop the vehicle as soon as it is safe to do so.
- Park the vehicle a safe distance from moving traffic.
- Switch on the emergency flashers.
- Never leave any persons, particularly children or people requiring assistance, in the vehicle. This is especially true when the doors are locked. Individuals locked in the vehicle could be exposed to very high or very low temperatures.

WARNING

Exhaust system components will become very hot. This can result in fires and serious injuries.

- Never park the vehicle in such a way so that any exhaust system components could come into contact with flammable materials under the vehicle such as dry grass or fuel.

NOTICE

Pushing the vehicle by hand may cause damage to the vehicle, such as deformation or detachment of attachments.

- When pushing the vehicle by hand, make sure that you do not apply any pressure to the taillights, large sheet metal surfaces and side or rear spoilers.

Checklist of what to do after an accident

In the event of an accident, for your own safety and the safety of your passengers, follow the points below in the order in which they are given:

1. Switch the ignition off.
2. Switch on the emergency flashers  ⇒ *Center console*.
3. Set up the warning triangle to warn others on the road about the vehicle.
4. Have all vehicle occupants exit the vehicle on the side facing away from traffic and move to a safe area, such as behind a guard rail. Provide first aid and follow the local regulations regarding wearing a reflective vest.
5. Report the accident to the fire department.
6. Wait at the location of the accident for the rescue services to arrive.

Switch on the emergency flashers in the following situations, for example:

- To warn traffic behind your vehicle if the traffic ahead slows suddenly or you reach the end of a traffic jam.
- If there has been an accident.
- If the vehicle malfunctions.
- When towing the vehicle.

Always follow the applicable local requirements for use of the emergency flashers.

If the emergency flashers do not work, others on the road must be informed about the stalled vehicle in some other way that meets the applicable legal regulations.

 The 12 V vehicle battery will drain if the emergency flashers remain on for a long period of time, even if the ignition is switched off.

 Depending on vehicle equipment, the brake lights may blink quickly if you brake hard while driving at speeds above approx. 80 km/h (approx. 50 mph) or brake the vehicle to a complete stop. This is done to warn traffic behind your vehicle. If the braking continues, the emergency flashers will switch on automatically when the vehicle speed is below approx. 10 km/h (approx. 6 mph). The emergency flashers will switch off automatically when you accelerate.

Emergency equipment

First aid kit

Depending on the country and the vehicle equipment, the first aid kit may be located in a storage compartment, in a holder in the luggage compartment, under the luggage compartment floor, or in the vehicle interior.

The first aid kit must meet the legal regulations.

- Note the expiration date of the contents.
- Replace contents after use, if necessary, and put the first aid kit securely back into place.

Warning triangle

Depending on the country and the vehicle equipment, the warning triangle may be located in a bag in the luggage compartment.

1. After use, store the warning triangle back in the sleeve and safely store the sleeve in the pocket in the luggage compartment.

The warning triangle must meet the legal regulations.

Reflective vest

Depending on the vehicle equipment and country of use, the safety vest may be in a storage compartment in the front door trim panel or in the glove compartment ⇒ *Driver door*, ⇒ *Passenger's side*.

The reflective vest must meet the legal regulations.

Fire extinguisher

Depending on the vehicle equipment and country of use, a fire extinguisher may be located in a holder in the footwell under the front passenger seat.

The fire extinguisher must meet the legal regulations, always be ready to operate, and be checked regularly – see inspection seal on the fire extinguisher.

WARNING

Objects that are loose or secured incorrectly can be thrown around the vehicle interior during sudden driving or braking maneuvers or in a collision and cause serious injuries.

- Always position the first aid kit, warning triangle and fire extinguisher securely in the holders provided in the vehicle.
- Store the reflective vest in a storage compartment so that it is easy to access.

Information Call, Roadside Assistance Call and Emergency Call Service



Fig. 34 Located on the roof console: Emergency Call Service button (behind a button cover) and indicator light.



Fig. 35 Located on the roof console: Emergency Call Service button.



Fig. 36 In the overhead console: Controls for the information call and roadside assistance call.

 Information call.





 Roadside assistance call.

The control in the roof console [fig. 34](#), [fig. 35](#), [fig. 36](#) can be used for voice services, depending on the vehicle equipment and country of use. The required connection is produced by a control module installed by the manufacturer.

 Note the additional information on VW Car-Net® ⇒ ®.

Indicator lights for the Emergency Call Service

An indicator light [fig. 34](#) (arrow) for voice and data transmission services is located in the control panel. The indicator light comes on in different colors and light patterns depending on the vehicle operating status of the Emergency Call Service:

 The indicator light does not light up: The vehicle is offline and has no connectivity.  The red indicator light comes on and remains on: system error. The Emergency Call Service is limited or not available.  The green indicator light lights up: Displays the availability of mobile radio signal. Does not display whether VW Car-Net services have been purchased and are active, except for the Emergency Call Service.  The indicator light blinks green: there is a call in progress.

Information call

- With an information call, a call can be made to the VW Car-Net call center for questions regarding VW Car-Net services.
- The information call is only available in certain sales regions.
- The information call can be executed whenever the ignition of the vehicle is switched on.
- The information call can be manually executed with the control panel in the roof console or the function key in the telephone menu of the Infotainment system.

Roadside assistance call

- If you break down, you can contact an authorized Volkswagen dealer or authorized Volkswagen Service Facility for assistance with the roadside assistance call.
- Some vehicle data, e.g. its current location, is transferred in parallel to the voice call.
- The Roadside Assistance Call can be executed whenever the ignition of the vehicle is switched on.
- Roadside Call Assist can be manually executed with the control panel in the roof console or the function key in the telephone menu of the Infotainment system.

Emergency Call Service

- Using the Emergency Call Service, assistance can be organized as quickly as possible in dangerous situations.

- The Emergency Call Service is only available if a corresponding license is acquired.
- If the Emergency Call Service is triggered, a call to the VW Car-Net call center will be made.
- If an emergency call is triggered manually or by a collision with airbag deployment or safety belt pretensioner deployment data that is relevant to the emergency call, such as the vehicle's current location, is automatically transmitted
⇒ *Customer information*.
- The contact partner will communicate in the language that is set in the vehicle's Infotainment system. If this language is not available at the current emergency call location, English will be used.

WARNING

The following conditions may restrict or prevent a manual or automatic emergency call:

- The emergency call location is in an area with no cell phone and satellite reception, or insufficient reception.
- You are in a location where there is sufficient mobile phone and satellite reception, but the mobile communications network of the required telecommunications providers is unavailable.
- The Emergency Call Service is not permitted by law in some countries.
- VW Car-Net has not been activated.
- No valid license for the use of the Emergency Call Service has been acquired or the license has expired.
- The vehicle components required for manual or automatic emergency calls are damaged or do not have sufficient power.
- The vehicle's ignition is not switched on.

Triggering an emergency call manually

1. If fitted, press on the button cover briefly and fold the cover downward.
2. Press the emergency call button *fig. 35* until the green indicator light starts to blink.

The emergency call is triggered and a voice call to the VW Car-Net call center is established.

If you pressed the emergency call button by mistake, cancel the emergency call immediately:

1. Press the emergency call button again until the indicator light remains green.

Automatic emergency call

The automatic emergency call is only triggered when the ignition is on.

A connection to the VW Car-Net response center is automatically established in the following situations:

- Immediately after the airbags have been deployed.
- Immediately after the safety belt pretensioners have been triggered.
- Depending on the vehicle equipment, in the event of a system intervention by the Emergency Assist system.

The automatic emergency call cannot be stopped by pressing the emergency call button *fig. 35*.

If questions from the VW Car-Net call center remain unanswered, rescue operations will automatically start.

Integrated battery

The integrated battery ensures that the Emergency Call Service will still be available for some time if the 12 V vehicle battery is disconnected or faulty.

If the integrated battery is drained or faulty, a message indicating this will be displayed in the instrument cluster. If this

message is shown, immediately consult an authorized Volkswagen dealer or authorized Volkswagen Service Facility and have the integrated battery replaced. Volkswagen recommends contacting an authorized Volkswagen dealer or authorized Volkswagen Service Facility.

 Have the integrated battery checked, and if necessary, replaced by an authorized Volkswagen dealer or authorized Volkswagen Service Facility after approximately three years. Volkswagen recommends contacting an authorized Volkswagen dealer or authorized Volkswagen Service Facility.

Data transmission

The available data will be sent to the VW Car-Net call center during an emergency call to determine what rescue measures are needed.

The data regarding the location of the vehicle is continuously overwritten, so that only the ten most recent saved locations as required for the Emergency Call Service to function are available. The vehicle cannot be tracked on a continuous basis.

The emergency call data is processed to ensure that the Emergency Call Service is functioning properly.



The following data is sent:

- The current vehicle position at the time the emergency call was triggered
- Nine other positions shortly before the emergency call was triggered (route driven, a few km (a few miles)).
- Vehicle Identification Number (VIN)
- Type of vehicle drive.
- Vehicle model
- Trigger type (automatic or manual)
- Call type.
- Direction in which the vehicle was moving at the time the emergency call was triggered.
- Accident severity.
- Accident direction.
- Time of impact
- Reliability of the positioning data
- Data set version.
- Counter of the data sets transmitted per call
- Calculated number of passengers.
- Language selected in the Infotainment system.
- Optional data ID.

 The Emergency Call Service function may be limited by any after-market Infotainment systems that are installed.

Troubleshooting

Emergency Call Service malfunction



The red indicator light in the emergency call button comes on and remains on . The message  Error: Emergency call function. Service vehicle may also be displayed in the instrument cluster.

There is a system error with the Emergency Call Service. You may not be able to make an emergency call.

1. Contact an authorized Volkswagen dealer or authorized Volkswagen Service Facility immediately and have the fault rectified. Volkswagen recommends contacting an authorized Volkswagen dealer or authorized Volkswagen Service

Facility.

Emergency Call Service limited

The red indicator light in the emergency call button comes on and remains on . The message  Emergency call function limited. Service vehicle may also be displayed in the instrument cluster.

The Emergency Call Service function has restricted availability. For example, you cannot make a voice call to the VW Car-Net® call center.

1. Contact an authorized Volkswagen dealer or authorized Volkswagen Service Facility immediately and have the fault rectified. Volkswagen recommends contacting an authorized Volkswagen dealer or authorized Volkswagen Service Facility.

Opening and Closing

Vehicle key

Vehicle key functions

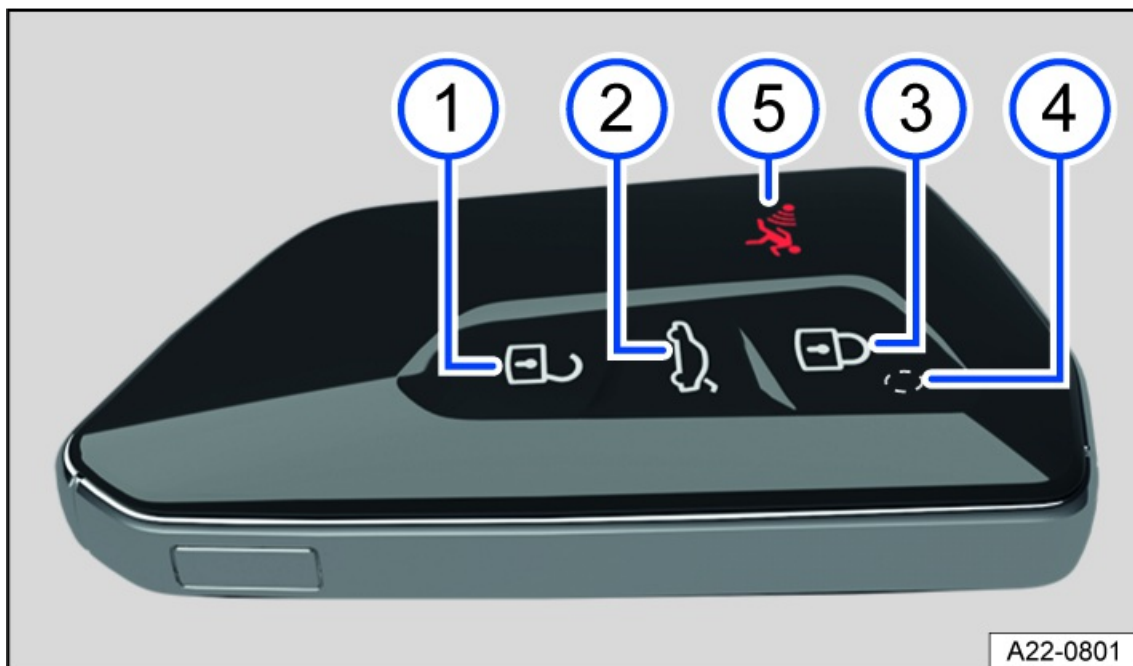

Fig. 37 Vehicle key.

- ① Unlock the vehicle. All turn signals will flash twice.
- ② Unlock the trunk lid separately. All turn signals will flash twice.
- ③ Lock the vehicle. All turn signals will flash once.
- ④ Indicator light: flashes when a button is pressed.
- ⑤ Panic button (depending on vehicle equipment).

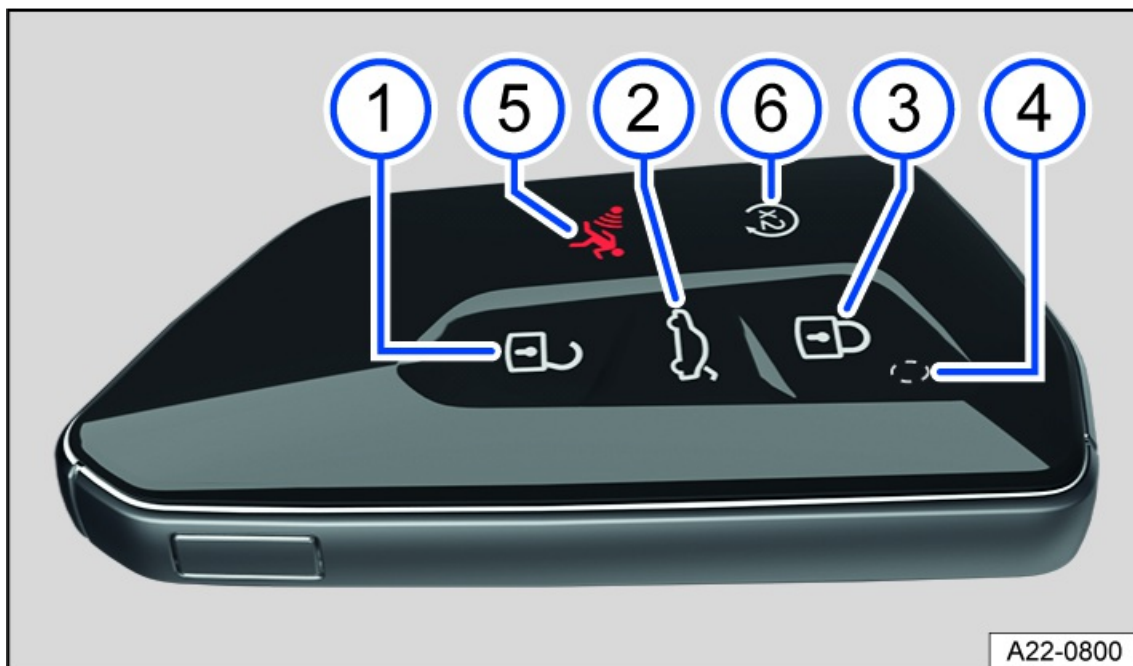



Fig. 38 Vehicle key with remote start relay function.



- ① Unlock the vehicle. All turn signals will flash twice.

- ② Unlock the trunk lid separately. All turn signals will flash twice.
- ③ Lock the vehicle. All turn signals will flash once.
- ④ Indicator light: flashes when a button is pressed.
- ⑤ Panic button (depending on vehicle equipment).
- ⑥ Remote start relay function (depending on the vehicle equipment).

Panic button (depending on vehicle equipment)

Only use the panic button  in case of an emergency. When you press the panic button, the horn will sound and the vehicle lights will flash. Pressing the panic button again switches off the alarm.

Remote start relay button (depending on vehicle equipment)

1. To carry out the remote start, press button  once and press button  twice ⇒ *Remote start relay function*.

During remote start, the parking light turns on. Pressing the  button switches off the engine.

WARNING

If you leave vehicle keys unattended in the vehicle, children or unauthorized people could lock the doors and/or the trunk lid, start the engine, or switch on the ignition and thereby activate electrical equipment, such as the power windows. This can cause accidents and serious or fatal injuries.

- Always take all vehicle keys with you when leaving the vehicle.

WARNING

If you leave children, people requiring assistance or animals unattended in the vehicle, they may accidentally set the vehicle in motion or be subjected to very high or low temperatures. There is a risk of accidents and serious or fatal injuries.

- Never leave children, people requiring assistance or animals unattended in the vehicle.

NOTICE

External influences may limit the functionality of the remote control vehicle key and damage it.

- Protect the vehicle key from moisture and strong impacts.

 Regular use of comfort systems and other usage patterns shorten the service life of the button cell in the vehicle key.

Emergency key



Fig. 39 Vehicle key: releasing the emergency key.

- ① Briefly press the release button. The key ring will fold open.
- ② Press the release button and pull out the emergency key in the direction of the arrow.
- ③ Emergency key.

An emergency key that can be used to manually unlock and lock the vehicle is located in the vehicle key *fig. 39*.

In the event of a discharged vehicle battery or vehicle key battery, it may be necessary to perform emergency locking or emergency release of the vehicle ⇒ *Locking the front passenger door and rear doors in an emergency* .

Replacing the button cell battery

Volkswagen recommends having the button cell changed by suitably qualified professionals. Volkswagen recommends contacting an authorized Volkswagen dealer or authorized Volkswagen Service Facility ⇒ ⚠.



Fig. 40 Remote control vehicle key: opening the battery compartment cover.

- ① Emergency key.

- 2 Lever out the cover.



Fig. 41 Vehicle key: replacing the button cell battery

1. Remove the emergency key *fig. 40*, ⇒ *Emergency key*.
2. Insert the emergency key in the slot, push it in the direction of the arrow and lever out the cover *fig. 40*.
3. Lift the button cell battery out of the battery compartment *fig. 41*, ⇒ ⚠.
4. Press the new button cell battery into the battery compartment.
5. Press the cover onto the housing *fig. 41*, ⇒ ⚠.
6. Store the emergency key ⇒ *Emergency key*.
7. Dispose of drained battery in a way that will not harm the environment.

⚠ DANGER

If button cell batteries are swallowed or enter the windpipe, serious or fatal injuries will occur within a very short time due to choking or internal burns.

- Seek medical assistance immediately if you suspect that a button cell battery has been swallowed.
- Always keep the remote control vehicle keys and key fob with button cell batteries out of the reach of children.

⚠ NOTICE

If the button cell battery is replaced incorrectly or a battery is unsuitable, it can damage the vehicle key.

- Only replace a drained battery with a new battery of the same voltage, size, and specification.
- Make sure the battery is facing in the right direction when inserting it.
- If the battery compartment cover cannot be closed, do not use the remote control.

🍃 The type of batteries used in the remote control of your vehicle key can contain perchlorate. This requires special handling. Observe all legal requirements regarding the handling and disposal of these batteries ⇒ *Product recycling*. Volkswagen recommends having this service carried out for you by suitably qualified professionals. Volkswagen recommends contacting an authorized Volkswagen dealer or authorized Volkswagen Service Facility.

Synchronizing a vehicle key

If the vehicle cannot be unlocked or locked using the vehicle key, synchronize the vehicle key or replace the button cell battery ⇒ [Replacing the button cell battery](#).

Synchronizing a vehicle key

1. Fold out the key bit or remove the emergency key.
2. If necessary, remove the cap from the driver's door handle ⇒ [Locking the front passenger door and rear doors in an emergency](#).
3. Press the  button on the vehicle key.
4. Unlock the vehicle using the key bit.
5. Open the driver door.

If the vehicle is equipped with an anti-theft alarm system, the alarm will be triggered immediately ⇒ [Anti-theft alarm system](#).

6. Switch the ignition on.

This completes the synchronization.

Troubleshooting

Vehicle cannot be locked or unlocked

The remote control vehicle key is disrupted by objects, poor weather conditions or transmitters on the same frequency band close to the vehicle (e.g. cell phones), as well as by a drained button cell battery.

1. Close the driver door.

Or: Synchronize the vehicle key ⇒ [Synchronizing a vehicle key](#).

Or: Change the battery cell in the vehicle key ⇒ [Replacing the button cell battery](#).

To protect the central locking from overloading, it switches off briefly.

1. Wait for about 10 seconds.
2. Try to activate the central locking again.

The indicator light is not blinking

If the indicator light in the vehicle key does not blink when you press one of the buttons, then the button cell battery in the vehicle key must be replaced.

Vehicle does not blink during locking

- All doors, the engine hood and the trunk lid must be completely closed. The turn signals will only blink if the vehicle is completely closed.
- Check that the vehicle key is close enough to the vehicle.
- Check the battery charge level of the key battery.

 The indicator light in the vehicle key must turn on briefly each time the buttons are pressed.

The central locking button lights up white

- The vehicle is unlocked.

- Close all the doors and press the central locking button in the door.
- If all the doors have been locked from the inside, the central locking button lights up yellow.
- If the central locking switch remains lit up white, the doors are not locked and there is a malfunction. Contact a qualified professional. Volkswagen recommends contacting an authorized Volkswagen dealer or authorized Volkswagen Service Facility.

The vehicle cannot be unlocked because the key battery is dead

1. Remove the emergency key from the vehicle key ⇒ *Emergency key*.
2. Insert the emergency key into the door lock cylinder and turn it counterclockwise.
For right-hand drive vehicles, turn the emergency key clockwise.
3. The driver door is mechanically unlocked.
4. Open the driver door.
5. Switch the ignition on. The alarm stops.
6. To unlock the remaining doors, press the central locking button in the door.

 Depending on the vehicle equipment, an alarm is triggered when the door is opened.

The vehicle cannot be unlocked because the vehicle battery is dead

1. Remove the emergency key from the vehicle key ⇒ *Emergency key*.
2. Insert the emergency key into the door lock cylinder and turn it counterclockwise.
For right-hand drive vehicles, turn the emergency key clockwise.
3. The driver door is mechanically unlocked.
4. Open the driver door.
5. If SAFELOCK was not engaged previously, all doors can now be opened and unlocked individually by pulling on the inside door handle.
6. The other doors cannot be opened when SAFELOCK is engaged.

Once the comfort battery has been charged, the central locking functions will become available again.

 You can get an additional or replacement vehicle key from an authorized Volkswagen dealer or authorized Volkswagen Service Facility.

“Keyless Access” with push-button start

Introduction

The Keyless Access with push-button start makes it possible to unlock and lock the vehicle without actively using the key. A valid vehicle key must be present within the vicinity of the vehicle to use this function.

Unlocking or locking using Keyless Access

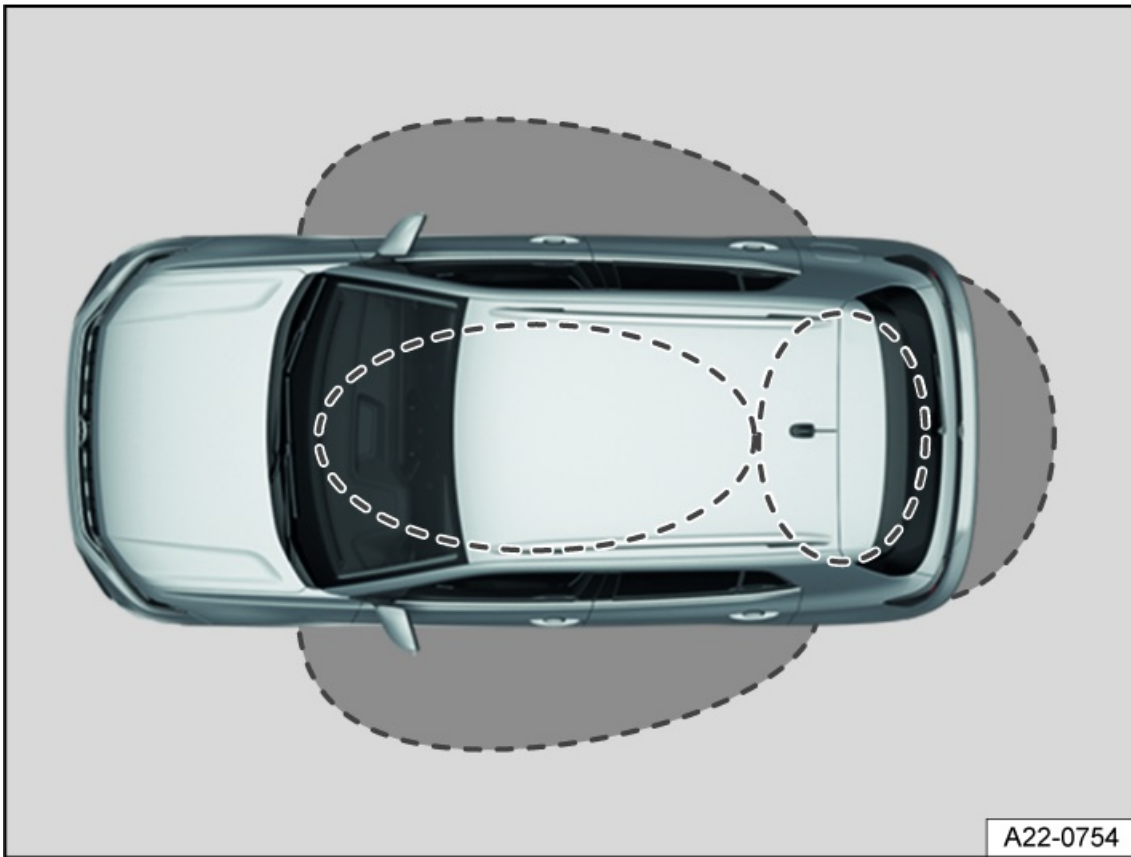

Fig. 42 Keyless Access: Sensor ranges (general example).

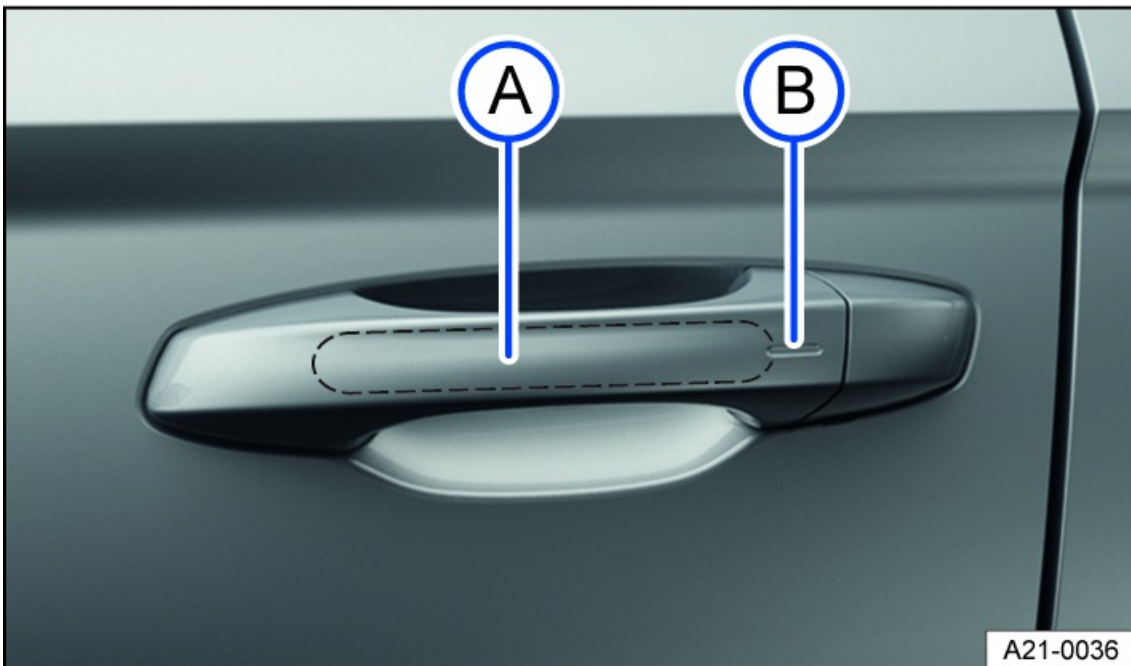

Fig. 43 In door handle: sensors.

- Ⓐ Sensor on the inside of the driver or passenger door handle.
- Ⓑ Sensor on the outside of the driver or passenger door handle.

Configuring Keyless Access

The behavior of the Keyless Access with push-button start can be set in the Opening and closing menu in the Infotainment system.

It is recommended that you always leave the Keyless Access with push-button start activated.

Unlocking the vehicle

1. Touch the sensor *fig. 43* on the inside of the driver or passenger door handle.

The turn signals flash twice when unlocking the vehicle.

Unlocking the vehicle upon approach

Depending on the vehicle equipment, the vehicle can be automatically unlocked upon approach. The following conditions must be met at the same time:

- ✓ The function is activated in the Infotainment system.
- ✓ The remote control vehicle key is in the vehicle unlocking area.

If automatic unlocking is successful, all of the turn signals will flash twice.

If the vehicle is not unlocked for a long period of time, the function will only be available again after the next time the engine is started.

If single door unlocking is activated, the driver door can only be unlocked by approaching the driver's side. Other doors will not be unlocked.

Locking the vehicle

1. Switch the ignition off.
2. Close the driver door or front passenger door.
3. Touch the sensor *fig. 43* on the outside of the driver or passenger door handle.

All turn signals flash once when locking the vehicle.

Locking the Vehicle Upon Exiting

Depending on the vehicle equipment, the vehicle can be locked automatically upon exiting. The following conditions must be met at the same time:

- ✓ The function is activated in the Infotainment system.
- ✓ The last key belonging to the vehicle exits the locking area.
- ✓ If automatic locking is successful, all of the turn signals will flash once.

If another vehicle key is in the vehicle, the vehicle will not lock automatically.

To deactivate automatic locking once:

1. Press the  button for longer than two seconds with a door open.

Automatic locking will be unavailable until the next time the vehicle is deliberately locked.

The vehicle will only lock if all of the doors and the trunk lid are closed. Depending on the vehicle settings, a double warning tone may sound to indicate open doors or windows.

If the key is within the detection range around the vehicle for a long period of time, there may be restrictions to locking upon exiting or unlocking upon approach.

 Some devices may prevent locking. The vehicle then remains unlocked without an audible warning. Always be aware of whether or not the vehicle is locked.

 If the vehicle is parked for a long time and has not been used, the vehicle can only be unlocked via the sensor on the inside of the driver door handle or the vehicle key.

Unlocking and locking the trunk lid

If the vehicle is locked and a vehicle key is within the trunk lid sensor range, the trunk lid will unlock automatically when opened *fig. 42*.

The trunk lid locks automatically after it closes.

The trunk lid will not lock automatically if the vehicle is completely unlocked.

Deactivating Keyless Access temporarily

You can temporarily deactivate Keyless Access with push-button start to prevent the vehicle from being unlocked and started by unauthorized people.

1. Lock the vehicle with the  button on the vehicle key.
2. Within five seconds of locking the vehicle, touch the sensor on the outside of the door handle once *fig. 43*. Do not grasp the door handle during this process.

Keyless Access is now temporarily deactivated.

3. To check that it has actually been deactivated, wait at least 10 seconds and then pull on the door handle.

The door should not open.

The next time the vehicle is unlocked, you must use the vehicle key. Keyless Access will be reactivated the next time the vehicle is unlocked.

Operating convenience functions

The electric windows close automatically.

On vehicles with a tilting and sliding panoramic sunroof, the sunroof also closes.

To close the windows automatically:

1. After you have exited the vehicle, press and hold the sensor on the driver or front passenger door handle for a few seconds *fig. 43*.

The sensor functions can be adjusted in the Vehicle settings menu in the Infotainment system.

 The unlock function is deactivated for several seconds so that you can check if the vehicle locked correctly.

 If the sensor is touched twice, the entire vehicle will unlock even after a single door is unlocked.

Troubleshooting

If Keyless Access is not working

The sensor function may be impaired if the sensor is dirty.

1. Clean the sensors.

If all turn signals flash four times

The vehicle key that was last used is still in the vehicle.

1. Remove the vehicle key and lock the vehicle.

Automatic sensor deactivation

The sensors will deactivate automatically under the following conditions:

- If the vehicle is not unlocked or locked for a long period of time
- If a sensor is triggered too frequently

Reactivating the sensor pads:

1. Unlock the vehicle using the  button on the vehicle key.

Valid vehicle key cannot be detected

The yellow indicator light turns on. A message will also appear in the instrument cluster display.

The vehicle key is no longer in the vehicle or within range of the sensors.

1. Do not switch the ignition off.
2. Bring the vehicle key back into the vehicle or within range of the sensors.

Or: depending on the vehicle equipment, remove the vehicle key from the immediate vicinity of the wireless charging function. Then place the vehicle key on the center console shelf.

If the problem persists, contact an authorized Volkswagen dealer or authorized Volkswagen Service Facility. Volkswagen recommends contacting an authorized Volkswagen dealer or authorized Volkswagen Service Facility.

 If at least one window is open and the sensors in one door handle are permanently activated, then all windows will close.

 If the message Keyless faulty. appears in the instrument cluster display, there may be a malfunction in the Keyless Access system. Contact a suitably qualified professional. Volkswagen recommends contacting an authorized Volkswagen dealer or authorized Volkswagen Service Facility.

Doors and central locking

Introduction

The doors can be manually locked and in some cases unlocked, for example if the vehicle key or the central locking system is malfunctioning.

The central locking system allows you to unlock and lock all doors, the trunk lid, and the fuel filler flap from one location.

The vehicle can be locked when the ignition has been switched off or if the driver has exited the vehicle when the engine is stopped.

Display for open doors

An image in the instrument cluster display indicates if one or more doors have not opened or closed correctly.

 Do not continue driving!

1. Safely park the vehicle, if necessary.
2. Open the respective door and close it again.

The image is also displayed when the ignition is switched off, and it turns off several seconds after the doors are closed and the vehicle has been locked.

WARNING

If a door is not closed correctly, it can open suddenly while driving and cause serious or fatal injuries.

- Stop immediately and close the door.
- When closing the door, make sure it engages securely and completely. When closed, the door must be flush with the areas of the vehicle body that are around the door.

WARNING

When the door is being held open by the door arrester, it may close by itself in high winds or on inclines, which can cause serious injuries.

- Always hold the door handle firmly when opening and closing the door.

WARNING

Opening and closing the doors and trunk lid without due care can be dangerous and result in serious injuries.

- Do not open or close the doors and trunk lid if anyone is in the way.

WARNING

The central locking system locks all the doors. In case of an emergency or accident, locked doors can make it more difficult for first responders to access the vehicle interior. When the vehicle is locked from the outside, the doors and power windows cannot be opened from the inside. There is a risk of serious or fatal injuries.

- Never leave children, people requiring assistance or animals unattended in the vehicle.

WARNING

All doors can be locked from the inside using the central locking button. Otherwise, children, people requiring assistance or animals could be locked inside the vehicle. In an emergency, they may not be able to exit the vehicle without assistance or help themselves. Otherwise, they may be subjected to very high or low temperatures. There is a risk of serious or fatal injuries.

- Never leave children, people requiring assistance or animals unattended in the vehicle.



NOTICE

Careless handling of the emergency lock components can result in vehicle damage.

- Use caution when using emergency locking or emergency unlocking.

 When the vehicle is locked from the inside, it reduces the risk of opening the doors unintentionally and of unauthorized people entering the vehicle.

Indicator light in the driver's door

 Please read the introductory information and heed the Warnings and Notice  and  *Introduction*.
The indicator light for the central locking system is located in the driver's door.

The indicator light shows the status of the central locking system for around 30 seconds after the vehicle is locked.

The red LED light blinks at short intervals for around 2 seconds.

The status of the central locking system is then displayed for around 28 seconds:

Vehicles without SAFELOCK

- If the red LED light blinks at long intervals, the vehicle will be locked.

After around 30 seconds, the LED light blinks at slow intervals.

Special conditions

If the red LED light comes on continuously, there is a fault in the central locking system or the anti-theft alarm system.

Automatic locking and unlocking

📖 Please read the introductory information and heed the Warnings and Notice ⇒ ⚠️ and ⚠️ *Introduction*. Depending on how your vehicle is equipped, settings for the central locking can be configured in the Vehicle settings menu in the Infotainment system.

Automatic locking (Auto Lock)

The vehicle locks automatically at speeds of approx. 15 km/h (approx. 9 mph) or higher. If the vehicle is locked, the  indicator light will turn yellow in the central locking button.

Automatic unlocking (Auto Unlock)

If one of the following conditions apply, all doors and the trunk lid will unlock automatically:

- **Or:** the electronic parking brake is engaged and the ignition is switched off.
- **Or:** if the door handle has been pulled.
- **Or:** if airbags have deployed during a collision ⇒ *Troubleshooting*.

 The Auto Unlock function makes it possible for first responders to access the inside of the vehicle.

Central locking button

📖 Please read the introductory information and heed the Warnings and Notice ⇒ ⚠️ and ⚠️ *Introduction*.



Fig. 44 In the driver's door: Central locking button (general example).

① Central locking button.



Fig. 45 In the driver's door: Button for powered opening of the trunk lid (general example).

① Button for powered opening of the trunk lid.

 – Unlock the vehicle.

 – Lock the vehicle.

 – Open the trunk lid.

The central locking button functions both when the ignition is on or off, but only when all the doors are closed.

If the  switch in the driver door is pulled, only the trunk lid will open. All doors remain locked.



If the vehicle is locked from the outside using the vehicle key, the central locking buttons will be disabled.

If the vehicle is locked from the inside using the central locking button, then:

- The  indicator light in the button will turn yellow if all doors are closed and locked.
- The anti-theft alarm system will not be activated ⇒ *Anti-theft alarm system*.

The doors can be opened from the inside by pulling the door handle. The  indicator light in the button turns off. The unopened doors and the trunk lid will remain locked and cannot be opened from the outside.

Opening and closing the driver's door in an emergency

 Please read the introductory information and heed the Warnings and Notice ⇒  and  *Introduction*.

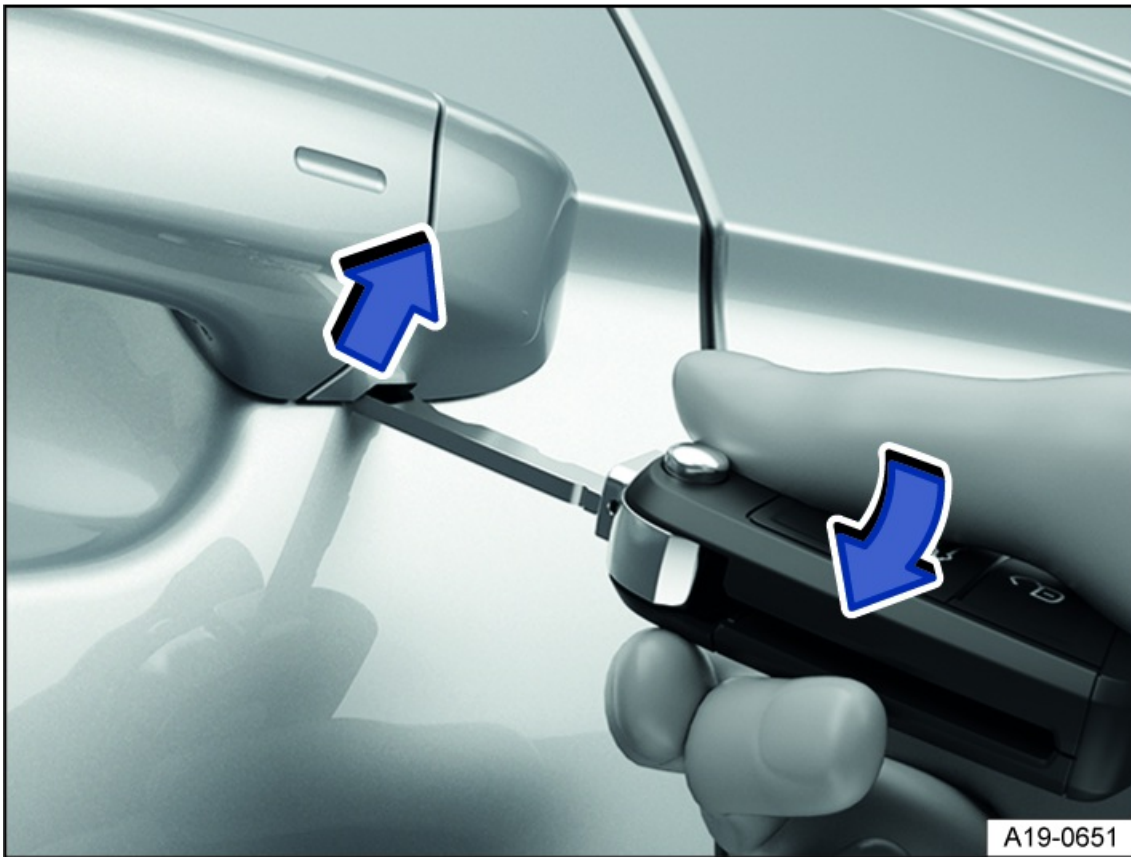

Fig. 46 Driver's door handle: prying off the cap.

When the vehicle is locked manually, all of the doors will lock. Only the driver door will unlock when unlocking manually.

Note the information about the anti-theft alarm system ⇒ [Anti-theft alarm system](#).

1. Position the key bit or emergency key on the notch in the driver door handle from below.
2. Hold your index finger under the key bit.
3. Use the vehicle key to pry the cap off in the direction of the arrow [fig. 46](#).
4. Insert the key bit in the lock cylinder and unlock or lock the vehicle.
5. Pull on the door handle and reinstall the cap.

Special considerations for manual unlocking

- An alarm is triggered when the driver's door is opened ⇒ [Anti-theft alarm system](#).
- An emergency start must be performed after unlocking ⇒ [Troubleshooting](#).
- Switch the ignition on to turn off the alarm.

The electronic immobilizer will detect a valid vehicle key.

 The anti-theft alarm system is not activated when the vehicle is manually locked using the key bit ⇒ [Anti-theft alarm system](#).

Locking the front passenger door and rear doors in an emergency



 Please read the introductory information and heed the Warnings and Notice ⇒  and  [Introduction](#).



Fig. 47 On the front of the right rear door: emergency locking the vehicle with the vehicle key (general example).

The front passenger door and the rear doors can each be locked manually.



The anti-theft alarm system is not activated when this happens ⇒ *Anti-theft alarm system*.

1. Open the door.
2. Insert the key bit or emergency key into the slot and turn it *fig. 47*.
3. Check that the door is locked.
4. Have the vehicle checked immediately by a suitably qualified professional. Volkswagen recommends contacting an authorized Volkswagen dealer or authorized Volkswagen Service Facility.

If a door is locked manually, it will unlock again when the vehicle is unlocked or if that door is opened from the inside.

 Doors can be unlocked and opened from the inside by pulling the door handle.

Child safety lock

 Please read the introductory information and heed the Warnings and Notice ⇒  and  *Introduction*.
The child safety locks are located on the inner door panels of the rear doors.

The child safety lock reduces the risk of the rear doors being opened from the inside ⇒ .

When the child safety lock is switched on, the door can only be opened from the outside.

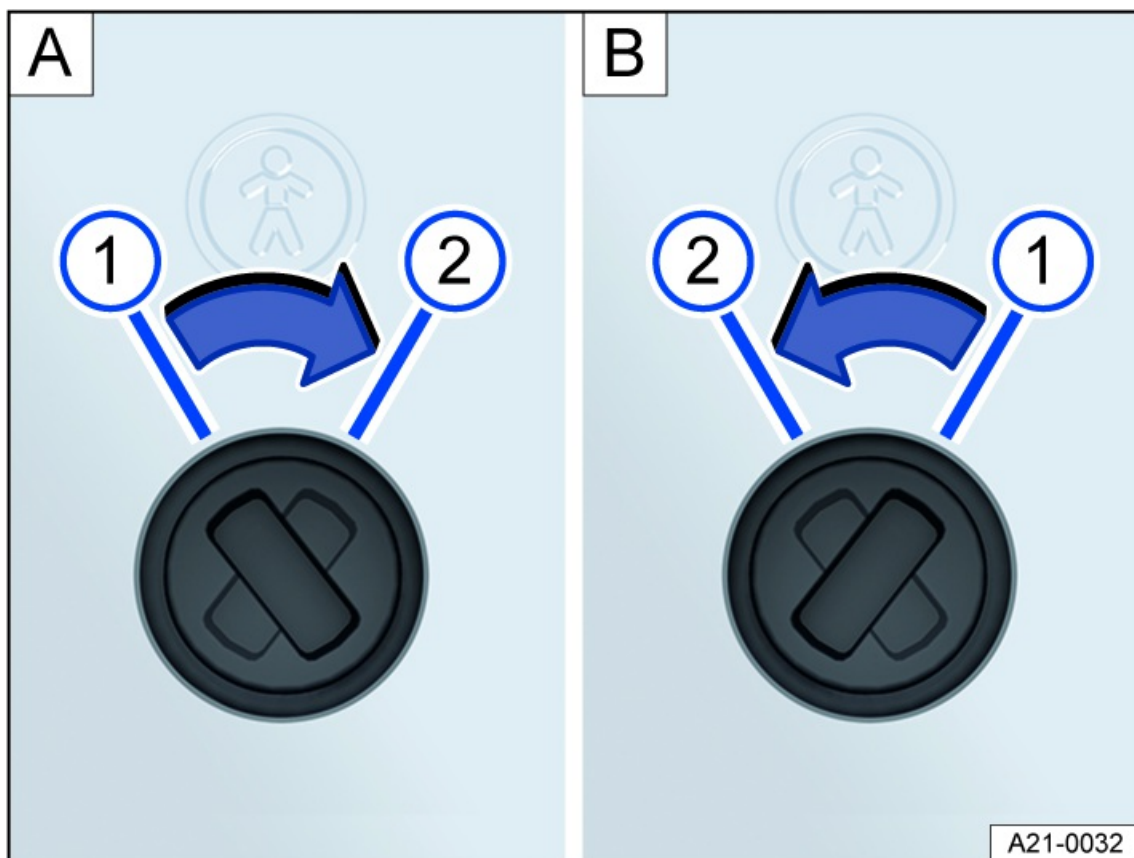

Fig. 48 Child safety lock: **A** left rear door, **B** right rear door.

- ① Child safety lock is switched off.
- ② Child safety lock is switched on.

Switching the child safety lock on or off

1. Unlock the vehicle the open the respective rear door.
2. Bring the slot into the corresponding position *fig. 48*.

⚠ WARNING

When the child safety lock is switched on, that door cannot be opened from the inside. This can result in people locking themselves inside the vehicle. In an emergency, they may not be able to exit the vehicle without assistance or help themselves.

- Never leave children or people requiring assistance unattended in the vehicle when the doors are locked.

⚠ WARNING

If you leave children, people requiring assistance or animals unattended in the vehicle, they may be subjected to very high or low temperatures. There is a risk of serious or fatal injuries.

- Never leave children, people requiring assistance or animals unattended in the vehicle.

Troubleshooting

📖 Please read the introductory information and heed the Warnings and Notice ⇒ ⚠ and ⚠ Introduction.

If the indicator light does not turn off

The red LED light in the vehicle door flashes at short intervals and then stays on.

There is a malfunction in the locking system.

1. Contact a suitably qualified professional. Volkswagen recommends contacting an authorized Volkswagen dealer or authorized Volkswagen Service Facility.

If the turn signals are not flashing

The turn signals are not blinking as confirmation when locking the vehicle.

1. Check that all of the doors, the trunk lid and the engine hood are closed.

If the vehicle is locking automatically

The vehicle will lock again automatically after approximately 45 seconds if all of the following conditions apply:

- The vehicle was unlocked using the vehicle key or Keyless Access with push-button start.
- The trunk lid was not opened.
- No door was opened.
- The ignition was not switched on

Emergency locking and opening on vehicles with lock cylinder open

1. For emergency unlocking, insert the vehicle key into the lock cylinder and turn it counterclockwise.

For right-hand drive vehicles, turn the remote control vehicle key clockwise.

Only the driver door opens and the anti-theft alarm system sounds.

2. Switch on the ignition to switch off the anti-theft alarm system.
3. The remaining doors can now be opened using the central locking button.

1. For emergency locking, insert the vehicle key in the lock and turn it clockwise.

For right-hand drive vehicles, turn the remote control vehicle key counterclockwise.

All doors are locked and the anti-theft alarm system is activated.

2. Check that all doors are locked.

Locking with a second vehicle key

For vehicles with Keyless Access with push-button start: The key inside the vehicle will be blocked from starting the engine if the vehicle is locked from the outside with a different vehicle key. However, an emergency start is possible.

1. To enable the vehicle key inside the vehicle so that it can be used to start the engine as usual, press the  button on the remote control vehicle key inside the vehicle

Unlocking and locking the vehicle following airbag deployment

The entire vehicle unlocks when an airbag deploys in a collision. The doors can be opened by firmly pulling on the door handles without a key.

Depending on the severity of the damage, it may be possible to lock the vehicle as follows after the accident:

1. Switch the ignition off.
2. Open the driver door and shut it again.
3. Lock the vehicle.

 It may not be possible to unlock or lock the vehicle using Keyless Access if the 12 V vehicle battery or button cell battery in the vehicle is weak or drained. The vehicle can be manually unlocked or locked.

 If there is no valid vehicle key in the vehicle or one is not detected, a message will appear in the instrument cluster display. This can occur if another signal interferes with the remote control vehicle key or if the remote control vehicle key is covered by an object, such as a metal case.

Anti-theft alarm system

The vehicle may be equipped with an anti-theft alarm system. The anti-theft alarm system monitors the doors, the hood, and the trunk lid. The anti-theft alarm system is automatically activated when you lock the vehicle. If an attempt is made to access the vehicle without using the appropriate vehicle key, this triggers the anti-theft alarm system, which emits audible and visual warning signals for up to five minutes.

When is the alarm triggered?

- If a door that was unlocked manually using the vehicle key is opened.
- If the hood is opened.
- If the trunk lid is opened.
- If the ignition is switched on with an invalid vehicle key.
- If the 12 V vehicle battery is disconnected.
- If a bicycle rack that is paired with the anti-theft alarm system is unhitched.
- If trailer that is paired with the anti-theft alarm system is unhitched.
- If a device is connected to the diagnostic connection when the anti-theft alarm system is active.

Switching off the alarm

1. Unlock the vehicle with the  unlock button on the vehicle key.

Or: switch on the ignition using a valid vehicle key.

2. *For vehicles with Keyless Access with push-button start:* when the vehicle key is in the unlocking range, grasp the door handle ⇒ *“Keyless Access” with push-button start.*

 The anti-theft alarm system will not work correctly if the 12 V vehicle battery is weak or drained.

 If you have integrated a trailer into the anti-theft alarm system, breaking the connection to the trailer may trigger the anti-theft alarm system ⇒ *Trailer towing.*

Trunk lid

Introduction

On vehicles with Keyless Access, the trunk lid is automatically unlocked when opening ⇒ *“Keyless Access” with push-button start.*

If individual door unlocking or the unlocking of one side of doors is activated in the Infotainment system settings for opening and closing, press the  button on the remote control vehicle key twice to unlock the trunk lid.

On vehicles with Keyless Access with push-button start, press the sensor on the inside of the driver or front passenger door handle twice depending on the setting.

WARNING

Uncontrolled or unintentional release: opening and closing the trunk lid can cause accidents and serious injuries.

- Do not open or close the trunk lid if anyone is in the way.
- Always keep the trunk lid closed while driving.

- Close and lock the trunk lid and all doors when the vehicle is not in use.
- Check that, when closed, the trunk lid is flush with the areas of the vehicle body around it.

WARNING

Depending on the season, the temperature inside the vehicle could become very high or low, which can lead to serious injuries, illness or death, especially for very young children.

- Make sure that no one remains in the vehicle.
- Never let children play in or on the vehicle unattended, especially when the trunk lid is open. Children could enter the luggage compartment, close the lid, and then lock themselves in.

WARNING

The vehicle may not always detect when the trunk lid is not latched if a cargo rack that is carrying cargo is mounted on the trunk lid. If the trunk lid is not latched, it may open suddenly while driving. This may cause serious injuries.

- Check that, when closed, the trunk lid is flush with the areas of the vehicle body around it.

WARNING

If there is a heavy load of snow or cargo on the trunk lid, the additional weight may cause the lid to lower, which can result in serious injuries.

- Never open the trunk lid if there is a heavy load of snow or cargo such as a cargo rack on it.
- Remove the snow or cargo before opening the trunk lid.
- If necessary, support the trunk lid or remove the cargo and/or snow before opening the trunk lid.

WARNING

Closing the trunk lid incorrectly may lead to the rear window shattering and cause serious injuries.

- Do not push the trunk lid closed with your hand on the rear window.

NOTICE

Using the opening mechanism incorrectly may damage the component and could prevent the trunk lid from closing.

- Never attach or secure cargo on the opening mechanism.

NOTICE

Using the rear window wiper incorrectly may damage the component and result in it breaking off.

- Never attach or secure cargo to the rear window wiper.

NOTICE

Using the trunk lid or rear spoiler incorrectly may damage the component and result in it breaking off.

- Never attach or secure cargo on the trunk lid or rear spoiler.

Opening and closing the trunk lid

📖 Please read the introductory information and heed the Warnings and Notice ⇒ ⚠️ and ⚠️ Introduction.

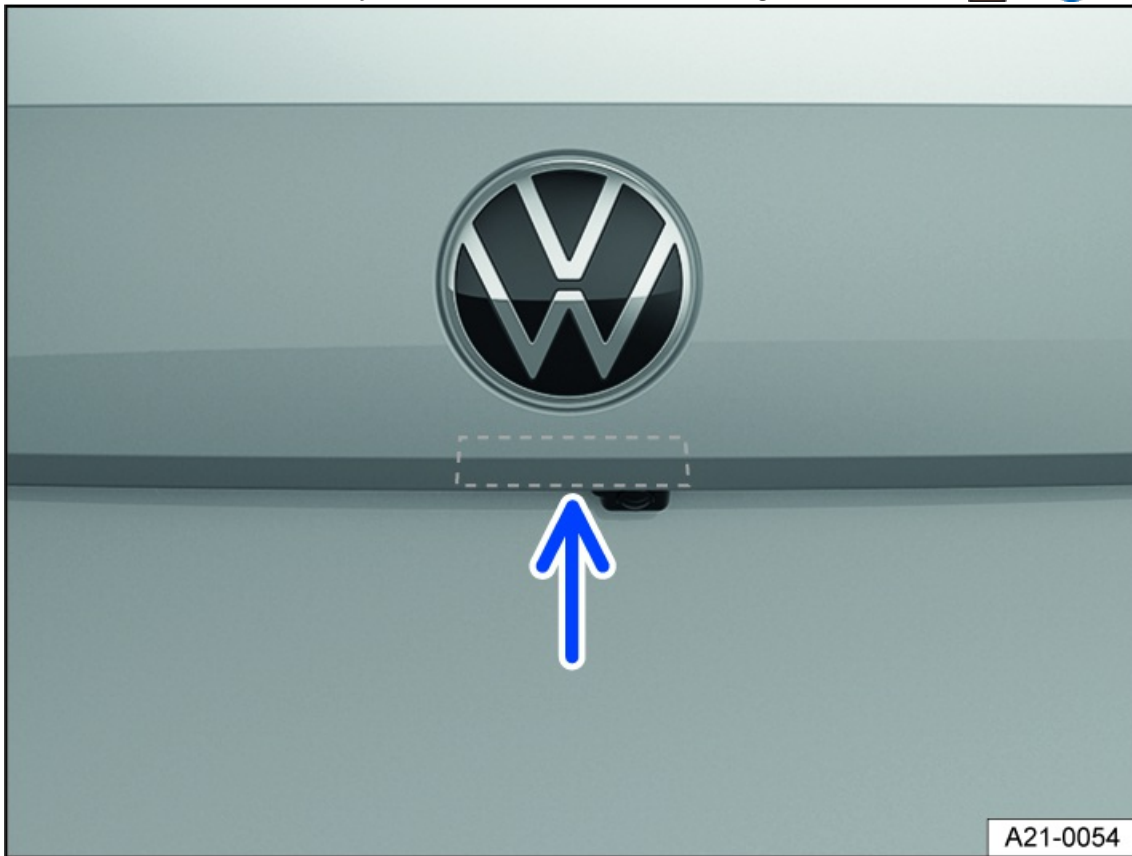

Fig. 49 In the trunk lid: Button to open the trunk lid (general example).



Fig. 50 In the open trunk lid: handle for closing the trunk lid (general example).

Opening the trunk lid

1. To unlock the trunk lid, press the  or  button on the vehicle key.

2. Raise the trunk lid using the button *fig. 49*.

Closing the trunk lid

1. Pull the trunk lid downward carefully using the handle in the interior trim panel until it latches shut in the lock *fig. 50*, ⇒



If the trunk lid is open or not closed correctly, an image in the digital instrument cluster display indicates this.

The trunk lid locks automatically while driving.

WARNING

Closing the trunk lid incorrectly or carelessly may lead to serious injuries.

- When opening the trunk lid, take care to pull it all the way up.
- When closing the trunk lid, make sure your hands are not within the closing range of the lid.

 If the trunk lid is not opened within several minutes after unlocking, it will lock again automatically.



Power opening and closing the trunk lid

 Please read the introductory information and heed the Warnings and Notice ⇒  and  *Introduction*.



Fig. 51 In the open trunk lid: Button for power closing the trunk lid.

Power opening the trunk lid

1. To unlock the trunk lid, press and briefly hold the  or  button on the remote control vehicle key.

Or: pull the  button in the driver door upward ⇒ *Central locking button*.

Or: press the button on the trunk lid.

The trunk lid will open automatically.

Power closing the trunk lid

1. Press the button in the trunk lid when it is open *fig. 51*.



Or: pull the  button in the driver door upward when the ignition is switched on until the trunk lid is closed.

Or: *On vehicles with Keyless Access with push-button start:* briefly press and hold the  button on the vehicle key. The vehicle key must be nearby to use this feature.

Or: Begin closing the trunk lid by hand until it closes by itself.

The trunk lid is closed.

Interrupting the opening or closing process

1. Press the  or  button while the lid is opening or closing.

Or: press the button on the trunk lid while the lid is opening or closing *fig. 51*.

The trunk lid can now be moved by hand. It is necessary to use more force when doing this.

Pressing the  button again moves the trunk lid back to the original position.

Chimes

When the trunk lid is opened or closed from inside the vehicle or using the vehicle key, chimes will sound.

Changing and saving the opening angle

If the space behind or above the vehicle is not large enough to allow the trunk lid to open completely, you can change how far the trunk lid opens.

1. Interrupt the opening process at the desired open position. It must be at least half open.
2. Press and hold the  button in the trunk lid until the emergency flashers start flashing *fig. 51*.

The adjusted opening angle is saved.

There will be an audible signal and the emergency flashers will flash to indicate that the setting was saved.

WARNING

Closing the trunk lid incorrectly or carelessly may lead to serious injuries.

- When closing the trunk lid, make sure your hands are not within the closing range of the lid.

NOTICE

If you open or close the trunk lid when there is not enough space, this may cause damage.

- Before opening or closing the trunk lid, check whether there is enough room, e.g. in garages.

Trunk lid with Easy Open motion sensor

 Please read the introductory information and heed the Warnings and Notice \Rightarrow  and  *Introduction*.

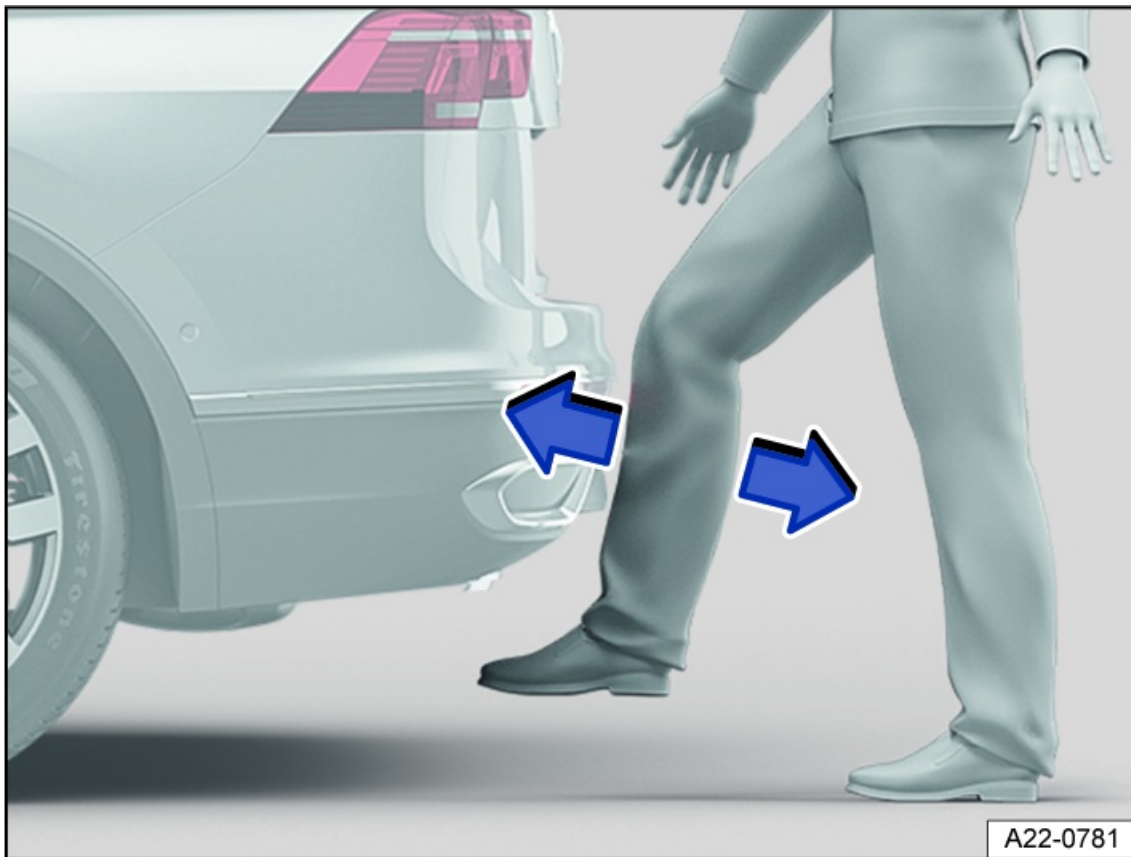

Fig. 52 General example of the sensor-controlled luggage compartment opener (Easy Open).

If a valid vehicle key is located near the trunk lid, the trunk lid can be unlocked and opened with foot motion.

1. Position your foot behind the middle of the bumper.
2. Quickly swing the lower part of your leg close to the bumper *fig. 52*.
3. Quickly remove the lower part of your leg once more from the bumper.

Visual feedback is given via the turn signals. The trunk lid will open.

The trunk lid will lock automatically after it closes if the vehicle was previously locked and there is not a valid vehicle key inside the vehicle.

Activating or deactivating the Easy Open function

The Easy Open function can be activated and deactivated in the Infotainment system:

1. Select the Vehicle menu.
2. Select the Settings submenu.
3. Scroll down the list and assign the settings under Opening and closing.

The sensor-controlled luggage compartment opener (Easy Open) function may be triggered inadvertently in the following situations:

- During refueling operations in which a tank hose is brought to the lower rear area of the vehicle.
- If there is a sweeping motion under the rear bumper.
- If a strong stream of water or steam passes.
- During maintenance and repair work in the area of the rear bumper.
- If there are moving gates in the vicinity of the bumper.

If a valid vehicle key is detected near the trunk lid, the sensor-controlled luggage compartment opener (Easy Open) function may trigger unintentionally and open the trunk lid in some cases. If the trunk lid opens unintentionally, it may cause injuries to people and/or damage to objects within the trunk lid's range of motion.

- After parking the vehicle, switch off the sensor-controlled luggage compartment opener (Easy Open) function via the Infotainment system if you park close to obstacles, e.g. street lamps, posts and garage doors, or if you park in an underground car park with a low ceiling.
- Always make sure that no valid vehicle keys are left unattended near the trunk lid.
- Always turn off the sensor-controlled luggage compartment opener (Easy Open) function via the Infotainment system before any and all maintenance and repair work is performed on the vehicle.
- Always turn off the sensor-controlled luggage compartment opener (Easy Open) function via the Infotainment system before washing the vehicle.
- Always switch off the sensor-controlled luggage compartment opener (Easy Open) function via the Infotainment system before mounting a bicycle rack or hitching a trailer ⇒  [Introduction](#).

Troubleshooting

 Please read the introductory information and heed the Warnings and Notice ⇒  and  [Introduction](#).

If the automatic trunk lid will not open or close

1. Check if the trunk lid is being blocked by an object.

The trunk lid can be moved by hand. It is necessary to use more force when doing this.

- If the trunk lid is operated too frequently within a short period of time, then the lid motor will automatically switch off to reduce the risk of overheating. Until the lid motor has cooled down, the trunk lid can be opened and closed by hand using extra force.
- When in trailer mode, the power trunk lid can only be opened and closed at the trunk lid.
- If the 12 V vehicle battery is disconnected or the fuse is malfunctioning, the trunk lid must be closed by hand.

If all turn signals flash four times

The vehicle key that was last used is still in the vehicle.

1. Remove the key and lock the vehicle.

If the manual trunk lid is difficult to move

The mechanism for opening the trunk lid may not always work automatically when the outside temperatures are around the freezing point.

1. Guide the trunk lid farther upward by hand.

The Easy Open sensor function is not working

- Easy Open only works when the ignition is switched off.
- Clean the sensors in the rear bumper.
- The trailer hitch is extended.
- The vehicle was retrofitted with a trailer hitch.
- Easy Open may be deactivated in heavy precipitation to reduce the risk of false activation.

Windows

Opening and closing the windows

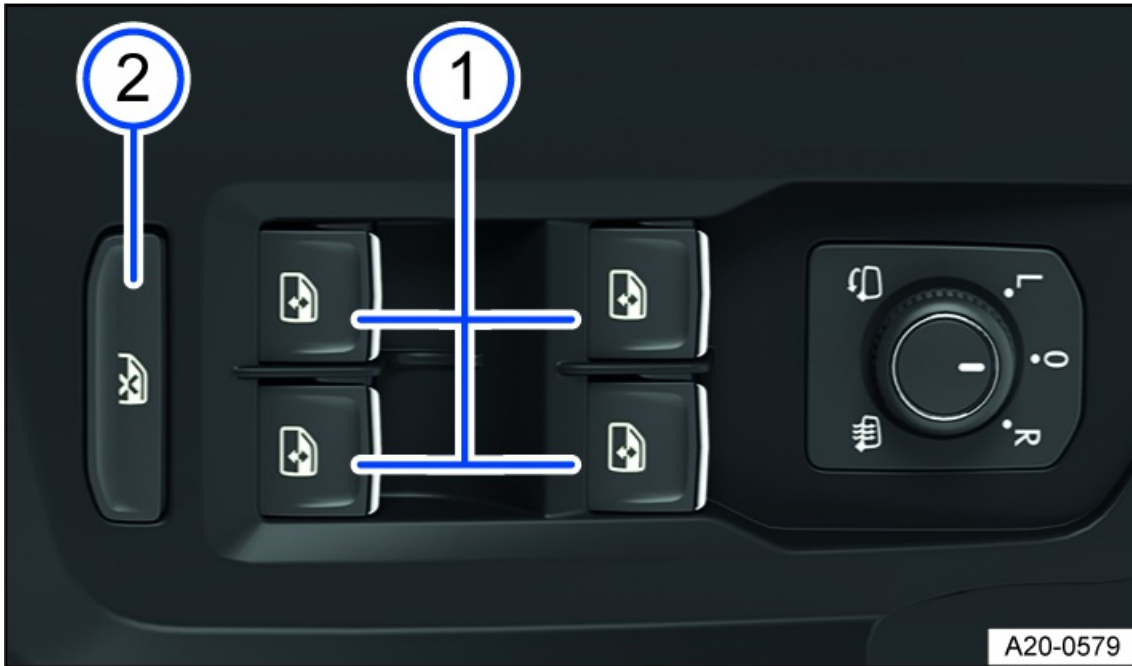

Fig. 53 In the driver door: Power window buttons.

- ① Opening the window: press the switch.
Closing the window: pull the switch.
- ② Deactivating the power window buttons in the rear doors: press the switch.
This button is only located in the driver door.

The windows can still be opened or closed using the switches in the doors for a brief period after the ignition has been switched off, as long as the driver's or front passenger door is not opened.

One-touch opening and closing function

The one-touch opening and closing function allows the windows to be completely opened or closed. To use this feature, do not hold the window switch up or down.

- To start the one-touch closing function, pull the window switch upward briefly to the second level.
- To start the one-touch opening function, press the window switch downward briefly to the second level.
- To stop the one-touch opening or closing function, pull or press the switch for that window again.

Convenience opening and closing

Opening

The windows can be opened from outside the vehicle using the vehicle key when the ignition is switched off.

1. Press and hold the unlock button on the vehicle key.
2. To stop the function, release the unlock button.

Closing

1. *On vehicles with Keyless Access with push-button start:* press the sensor surface or locking button on the door handle for a few seconds, until the windows are closed ⇒ *"Keyless Access" with push-button start*. The vehicle key must be nearby to use this feature.

When all of the windows and the power sunroof are closed, the turn signals will blink *once* as a confirmation.

2. To stop the function, remove your finger from the sensor or switch.

You can select the convenience opening settings in the Vehicle settings menu in the Infotainment system.

WARNING

Careless or unintended use of the power windows can cause serious injuries.

- Do not open or close the power windows if anyone is in the way.
- Always take all vehicle keys with you when leaving the vehicle.
- Note that the windows can still be opened or closed using the door buttons for a brief period after the ignition has been switched off, as long as the driver's or front passenger door is not opened.
- When driving with children seated on the rear bench seat, always disable the rear power windows so that the windows cannot be opened or closed.

WARNING

If the vehicle is locked, the windows can no longer be opened and will prevent people from escaping from the vehicle interior. In an emergency, this could cause serious or fatal injuries.

- Never leave children or people requiring assistance unattended in the vehicle when the vehicle is locked.

NOTICE

If the windows are open, precipitation can enter the vehicle and soak the interior equipment, which could restrict the function of the controls or damage them.

- Close all windows if there is precipitation.

 If the power windows are malfunctioning, the one-touch opening and closing function and the pinch protection may not function correctly. Contact a suitably qualified professional. Volkswagen recommends contacting an authorized Volkswagen dealer or authorized Volkswagen Service Facility.

 Convenience opening and closing only functions if the one-touch opening and closing function is activated for all the power windows.

Power window pinch protection

The power window pinch protection can reduce the risk of being pinched and injured when the windows are closing.

If the window cannot close due to resistance or an obstacle, then the window will reopen immediately ⇒ .

1. Check why the window did not close.
2. Try again to close the window.

If the window will not close again, then the pinch protection will be disabled for several seconds.

If the window still cannot close, then the window will stop at the place where it meets resistance. If you pull on the power window switch again within a few seconds, the window will close without pinch protection ⇒ .

Closing windows without pinch protection

1. Try to close the window again within a few seconds by holding the power window switch. This will disable the pinch protection.

If the closing process takes longer than several seconds, then pinch protection will be enabled again. If there is resistance to the window moving or an obstacle is blocking the window, then the window will reopen automatically.

2. If the window still cannot close, then contact a suitably qualified professional. Volkswagen recommends contacting an authorized Volkswagen dealer or authorized Volkswagen Service Facility.

WARNING

Closing the window when pinch protection is disabled can result in serious injuries.

- Always be careful when closing the windows.
- Do not close windows if anyone is in the way.
- Note that the pinch protection does not prevent fingers or body parts from being trapped against the window frame.

 Pinch protection is also active during convenience closing.

Troubleshooting

One-touch up/down feature

If the 12 V vehicle battery is disconnected or drained when the windows are not completely closed, then the one-touch up/down feature will not work. It must be reprogrammed using the following steps:

1. Switch the ignition on.
2. Close all windows and doors.
3. Pull the switch for the desired window and hold it in that position for several seconds.
4. Release the switch, then pull it upward again and hold it.

The one-touch up and down features will then be fully functional.

The automatic power windows can be reprogrammed individually, or multiple windows can be reprogrammed at the same time.

Controls are responding differently than expected

Moisture, dirt and grease may limit the functioning of the controls.

1. Always keep the control panels clean and dry.

Sunroof

Opening and closing the tilting and sliding panoramic sunroof

The term “sunroof” is used as a synonym for the panoramic sliding/tilting sunroof.

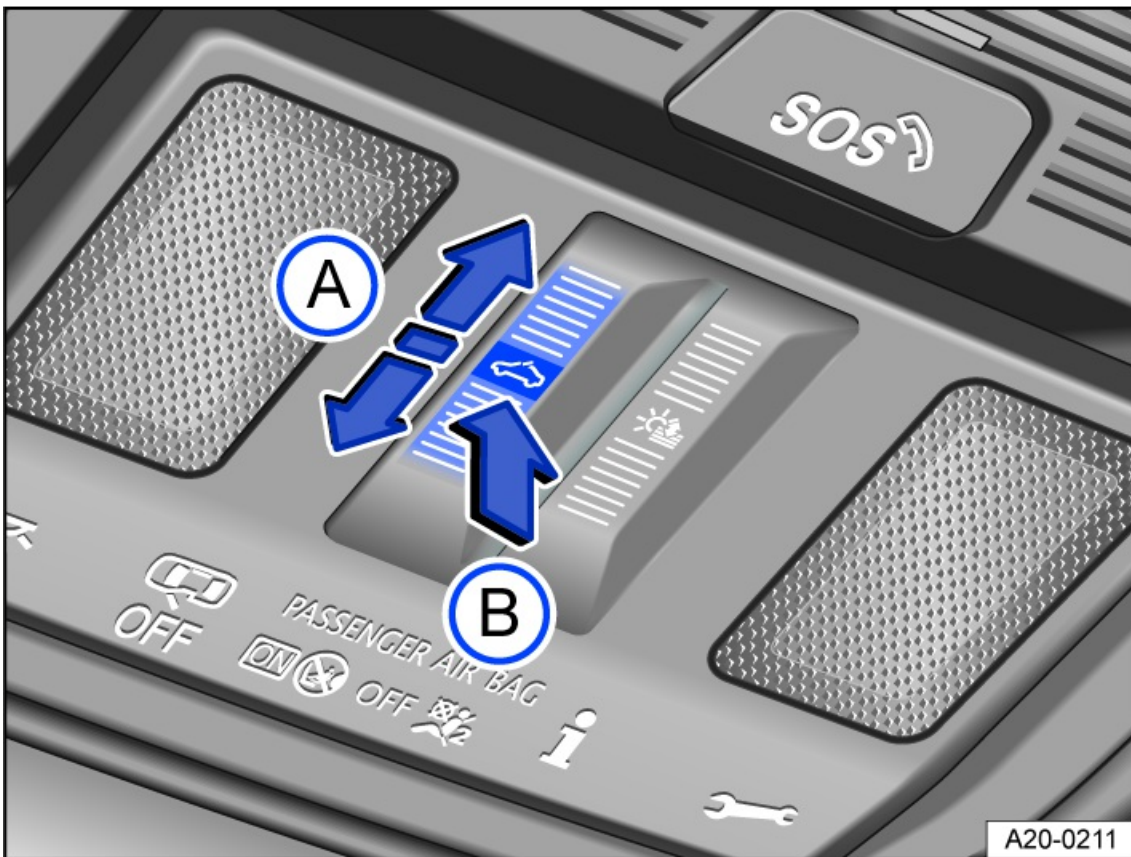



Fig. 54 In the headliner: Control for the tilting and sliding panoramic sunroof.

- Ⓐ Open or close the tilting and sliding panoramic sunroof.
- Ⓑ Tilt the tilting and sliding panoramic sunroof, close the tilting and sliding panoramic sunroof or stop the automatic process.



The  control can be operated in two ways: Swiping and tapping.

Swipe: Fully or partially open and close the roof.



Tap: Fully or partially tilt, open or close the roof.

You can stop the automatic process by tapping the control again.



Opening the power sunroof

- Automatic process: swipe back on the  control *fig. 54*.
- Manual process: swipe back on the  control and hold.

Closing the power sunroof

- Automatic process: swipe forward on the  control *fig. 54*.
- Manual process: swipe forward on the  control and hold.

Tilting the power sunroof

- Automatic process: Briefly tap the center of the  button *fig. 54*.
- Manual process: Tap the  control and hold.

Tilting the tilting and sliding panoramic sunroof is only possible when the roof is closed. If necessary, close the roof beforehand.

Closing the power sunroof when tilted

1. Briefly tap the center of the  button *fig. 54*.

Stopping the automatic opening or closing process

1. Tap the  button again *fig. 54*.

WARNING

Careless or unintended use of the power sunroof may cause serious or fatal injuries.

- Do not open or close the power sunroof if anyone is in its path.
- Note that the power sunroof can still be opened or closed for a brief period after the ignition has been switched off, as long as the driver's or front passenger door has not been opened.

WARNING

If you leave vehicle keys unattended in the vehicle, children or unauthorized people may lock the vehicle, start the engine, switch on the ignition or activate the power sunroof. This can cause accidents and serious or fatal injuries.

- Always take all vehicle keys with you when leaving the vehicle.

CAUTION

Depending on the vehicle equipment, the tilted position of the tilting and sliding panoramic sunroof may change automatically above a certain speed to reduce wind noise. When it moves, the tilting and sliding panoramic sunroof can cause damage and injuries.

- Always ensure that no body parts or objects are within the opening range of the power sunroof.

NOTICE

Opening or tilting the power sunroof when there is precipitation, particularly snow and ice, may cause damage to the vehicle interior and the electrical system.

- Remove snow and ice from the vehicle roof before using the power sunroof in winter temperatures.
- Always close the power sunroof before leaving the vehicle and when there is precipitation.

NOTICE

If you use a power sunroof with a roof rack mounted, the power sunroof may be damaged.

- Keep the power sunroof closed when using a roof rack.

 Remove leaves and other loose objects from the power sunroof guide rails regularly, either by hand or with a vacuum cleaner.

 The pinch protection will not function correctly if the sunroof is malfunctioning. Contact a suitably qualified professional. Volkswagen recommends contacting an authorized Volkswagen dealer or authorized Volkswagen Service Facility.

Tilting and sliding panoramic sunroof convenience opening and closing

Convenience opening and closing

The sunroof can be opened and closed from outside the vehicle using the vehicle key.

- Does not apply to the US or Canada: Press and hold the unlock or lock button on the vehicle key. The tilting and sliding panoramic sunroof and the blind are opened or closed.
- For vehicles with Keyless Access with push-button start: Hold your finger on the unlock sensor in the door handle for several seconds until the tilting and sliding panoramic sunroof is closed ⇒ *Unlocking or locking using Keyless Access*.
- Remove your finger from the unlock or lock button to stop the function.

When using the convenience closing function, all windows in the doors and the sunroof will be closed. When all of the windows and the power sunroof are closed, the turn signals will blink once as a confirmation.

Settings for the sunroof can be adjusted in the vehicle settings in the Infotainment system. You can activate convenience opening in the Infotainment system.

Sunroof pinch protection

The pinch protection reduces the risk of pinching injuries ⇒ . If the sunroof is obstructed while it is closing, it will open again automatically.

1. Check why the sunroof is not closing.
2. Try again to close the sunroof.
3. If the sunroof is still not able to close, close the sunroof without pinch protection.

Closing the sunroof without pinch protection

1. Try again to close the sunroof.
2. If the power sunroof still cannot be closed, swipe forward over the function key  within 5 seconds and hold until the power sunroof is completely closed ⇒ *Opening and closing the tilting and sliding panoramic sunroof*.
3. If the power sunroof still cannot close, then contact a suitably qualified professional. Volkswagen recommends contacting an authorized Volkswagen dealer or authorized Volkswagen Service Facility.

If you release the button during the closing process, the power sunroof will open again automatically.

WARNING

Closing the power sunroof without pinch protection may result in serious or fatal injuries.

- Always be careful when closing the power sunroof.
- Do not close the power sunroof if anyone is in its way, especially if it is closing without pinch protection.
- Note that the pinch protection does not prevent fingers or body parts from being trapped against the roof frame.

 Pinch protection also occurs when convenience closing the windows and sunroof with the vehicle key.

Troubleshooting

If the sunroof is not closing

- The sunroof only works when the ignition is on. The sunroof can still be opened or closed for a brief period after the ignition has been switched off, as long as the driver's or front passenger's door has not been opened.
- If it is not possible to close the sunroof using the power controls, the sunroof must be closed manually. Some vehicle components must be removed in order to close the sunroof manually. Contact a suitably qualified professional. Volkswagen recommends contacting an authorized Volkswagen dealer or authorized Volkswagen Service Facility.

Controls are responding differently than expected

Moisture, dirt and grease may limit the functioning of the controls.

1. Always keep the control panels clean and dry.

Steering wheel

Adjusting the steering wheel position mechanically

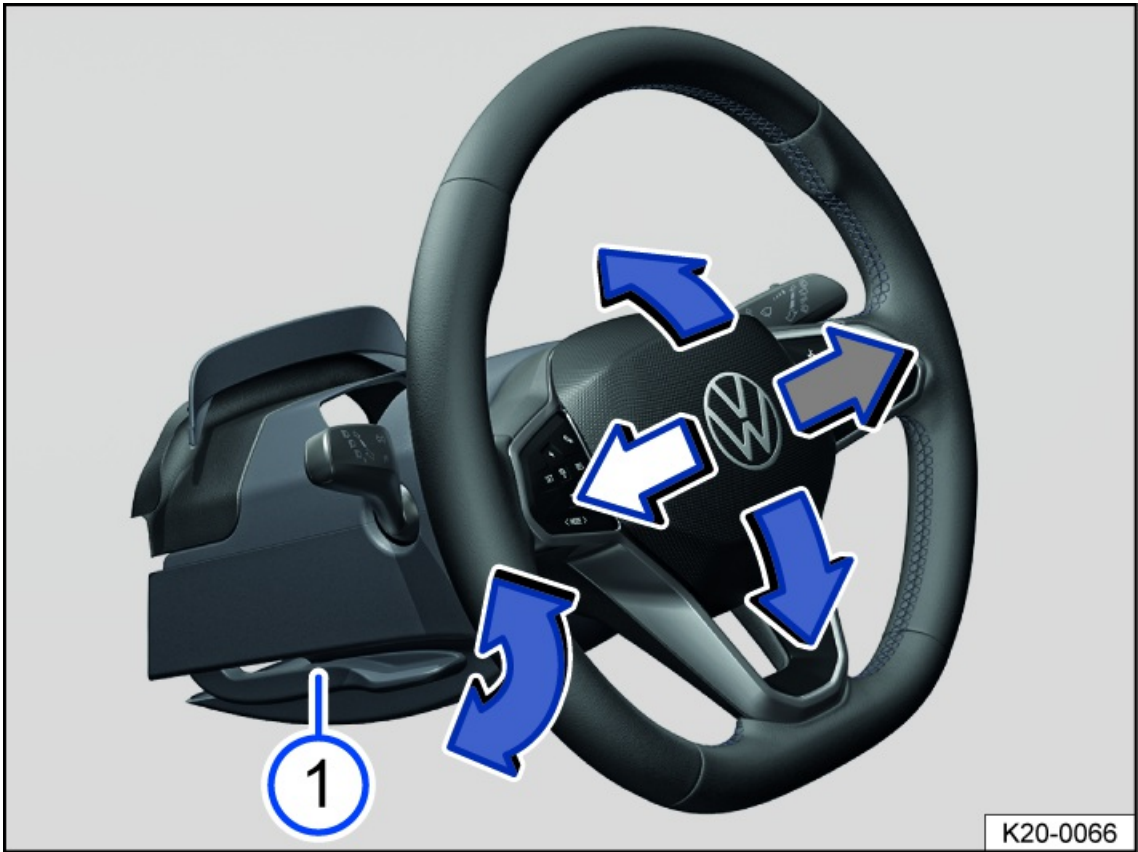



Fig. 55 Under the steering wheel in the steering column trim panel: lever to adjust the steering wheel position manually (general example).



Fig. 56 On the steering wheel: nine o'clock and three o'clock position (general example).

Only adjust the steering wheel before driving or while the vehicle is stationary ⇒ .

1. Tilt the lever *fig. 55* downward.
2. Adjust the steering wheel so that it can be firmly held at the outer edge with both hands at the nine o'clock and three o'clock position *fig. 56*.
3. Press the lever all the way up until it locks flush with the steering column trim panel ⇒ .

WARNING

Incorrect use of the steering wheel adjuster and an incorrect steering wheel adjustment could cause serious or fatal injuries.

- Always push the lever *fig. 55* upward into its locked position after adjusting so that you do not change the steering wheel position unintentionally while driving.
- Never adjust the steering wheel while driving. If you find the steering wheel must be adjusted while driving, stop the vehicle safely and adjust the steering wheel correctly.
- The steering wheel must always face toward the chest and never toward the face. Otherwise, the protective function of the driver's front airbag may be limited in the event of an accident.
- To reduce the risk of injuries if the driver's front airbag deploys, always hold the outer edge of the steering wheel firmly with both hands in the nine o'clock and three o'clock position *fig. 56*.
- Never hold the steering wheel in the twelve o'clock position or in any other way, such as holding the center of the steering wheel. Otherwise, the arms, hands, and head could be seriously injured if the driver's front airbag deploys.

Seats and head restraints

Front seats

Introduction

The following information describes the various options for adjusting the front seats. Always make sure the seats are adjusted to the correct position ⇒  [Introduction](#).

WARNING

Driving in an incorrect seating position due to seats being adjusted incorrectly may cause serious injuries.

- Adjust the front seats according to the correct seating position each time before driving and make sure all passengers have their safety belts fastened correctly.
- Move the front passenger seat all the way back.

WARNING

Adjusting the seats incorrectly can cause accidents and serious injuries.

- Only adjust the seats when the vehicle is stationary. Otherwise, the position of the seats could change unexpectedly while driving and you could lose control of the vehicle. You could also put yourself in an incorrect seating position.
- Only adjust the height, angle, and forward/back position of the front seats when there is no one within the seat's range of movement.
- Do not restrict the movement of the seats by placing objects within their range of movement.
- The adjusting and locking areas of the seats must not be dirty.

WARNING

Using seat covers or protective covers incorrectly can result in unintentionally operating the seat adjusters, and the front seats could move unexpectedly while driving. This could cause you to lose control of the vehicle. This can cause accidents and injuries. The electrical components in the front seats could also be damaged.

- Never install or secure seat covers and protective covers on the electrical controls.
- Only use seat covers or protective covers that are specifically approved for use in your vehicle.

WARNING

Lighters in the vehicle can become damaged or ignite unintentionally. This can cause severe burns and vehicle damage.

- Before adjusting any seat, always make sure that there are no cigarette lighters near the moving parts of the seat.

NOTICE

Objects with sharp edges can damage the seats.

- Never touch the seats with sharp-edged objects. Sharp-edged objects, such as zippers, rivets on clothing, or belts,

can cause surface damage. Open hook and loop fasteners can also cause damage.

Manually adjusting front seats

📖 Please read the introductory information and heed the Warnings and Notice ⇒ ⚠️ and ⚠️ *Introduction*.

The information that follows describes all possible controls. Depending on the seat version, the number of controls may vary.

The controls on the front passenger seat are a mirror image of those for the driver seat.

A seat may have both manual and power controls.



Fig. 57 On the driver seat: Controls.

- ① Pull the lever to slide the front seat forward or backward. The front seat must lock into place after the lever is released.
- ② Press and hold the lever to adjust the tilt of the backrest, and release it once the seat backrest is in the preferred position. Release the lever to secure the backrest. The seat backrest must lock into place after the lever is released.
- ③ If necessary, move the lever upward or downward multiple times to adjust the height of the seat.

Adjusting power front seats

📖 Please read the introductory information and heed the Warnings and Notice ⇒ ⚠️ and ⚠️ *Introduction*.

The electric controls differ depending on the country and vehicle equipment and may vary according to the seat design.

The controls on the front passenger seat are a mirror image of those for the driver seat.

A seat may have both manual and power controls.

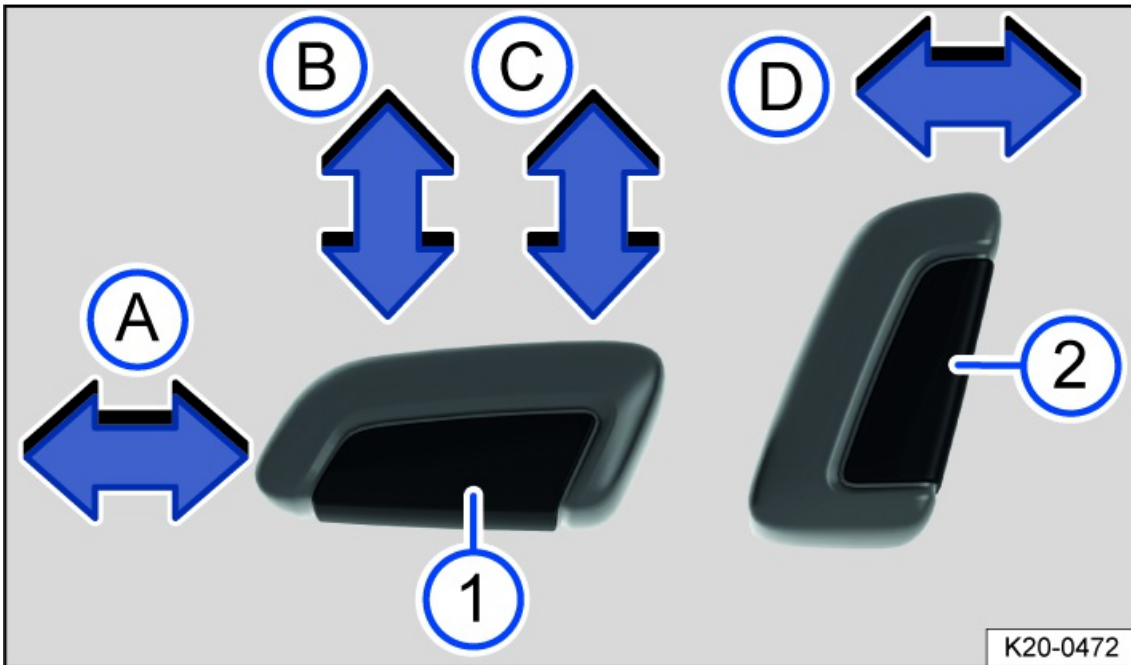

Fig. 58 Switch on the driver seat: Adjusting the front seat forward/back, the height and angle of the seat surface, and the front seat backrest.

Press the switch in the direction of the arrow:

- Ⓐ Slide the seat forward or backward.
- Ⓑ Adjust the angle of the seat surface.
- Ⓒ Adjust the height of the seat.
- Ⓓ Adjust the angle of the backrest.

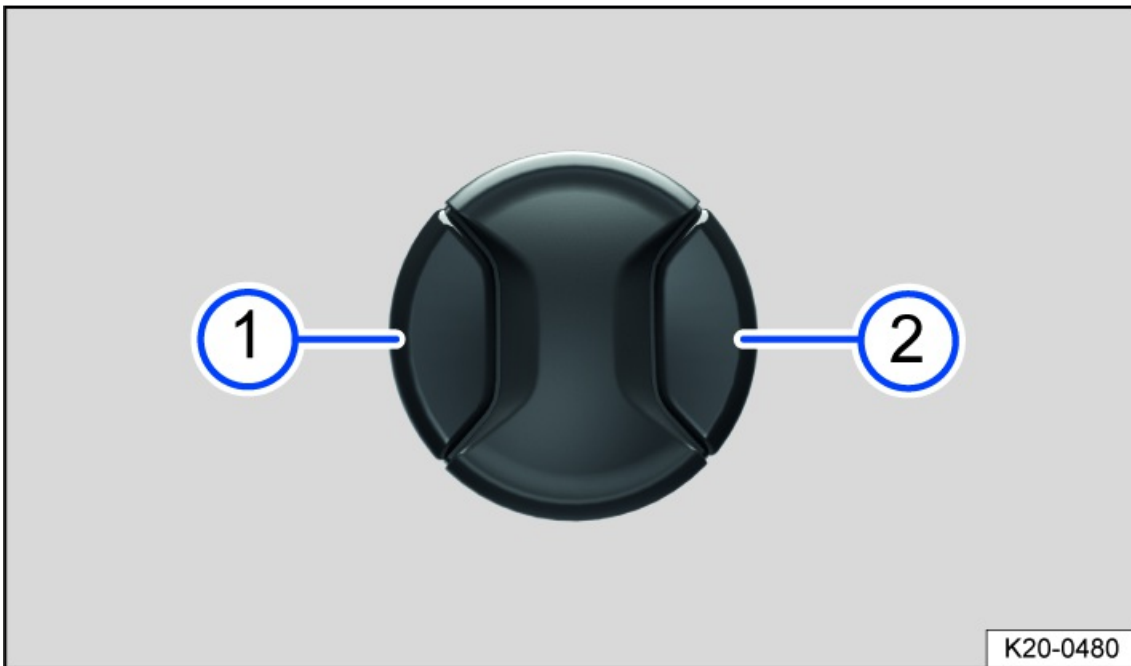

Fig. 59 Switch on the driver seat: Adjusting the lumbar support.

Press the switch in the direction you would like the lumbar support to move.

- ① Move the curvature of the lumbar support forward.
- ② Move the curvature of the lumbar support backward.

⚠ WARNING

Careless or unintended use of the power front seats can cause serious injuries.

- The power front seats can also be adjusted when the ignition is switched off. Never leave children or people requiring assistance in the vehicle.
- In case of an emergency, interrupt the power adjustment by pressing another switch.

! NOTICE

Incorrect usage may damage the electric components in the front seats.

- Do not kneel on the front seats and do not otherwise concentrate pressure on specific points of the seat cushion and backrest.

 If the charge level of the 12-volt vehicle battery is too low, it may not be possible to adjust the seat electronically.

 Seat adjustment is canceled while the engine is starting.

Rear seats

Introduction

The following information describes the various options for adjusting the rear seats. Always make sure the seats are adjusted to the correct position ⇒ *Correct seating position*.

WARNING

Incorrectly positioned rear seats increase the risk of serious injuries if an accident occurs.

- Before every journey, ensure that the rear seats are positioned so that all passengers are sitting upright and have their safety belts fastened correctly.
- Only adjust the rear seats when there is no one within the range of movement of the seats.

WARNING

If you adjust the rear seats while driving, you will adopt the wrong sitting position. In addition, the rear seats may move unexpectedly during the journey. This will increase the risk of serious injuries if an accident occurs.

- Only adjust the rear seats when the vehicle is stationary.

WARNING

Lighters in the vehicle can become damaged or ignite unintentionally. This can cause severe burns and vehicle damage.

- Before adjusting any seat, always make sure that there are no cigarette lighters near the moving parts of the seat.

WARNING

Incorrect use of the rear center armrest may cause serious injuries.

- The rear center armrest must always be folded up during journeys.
- If the center armrest is folded down, the center rear bench seat must never be used by either adults or children.

- Never allow an adult or child to ride on the center armrest.

! NOTICE

Objects in the luggage compartment may get into the space between the seat and the luggage compartment floor when the rear seat is adjusted. This may cause damage.

- Remove all objects located between the seat and luggage compartment floor before you move the rear seat.

! NOTICE

Objects with sharp edges can damage the seats.

- Never touch the seats with sharp-edged objects. Sharp-edged objects, such as zippers, rivets on clothing, or belts, can cause surface damage. Open hook and loop fasteners can also cause damage.

Adjusting the rear bench seat

📖 Please read the introductory information and heed the Warnings and Notice ⇒ ⚠️ and ! *Introduction*.

Depending on the vehicle equipment, the rear bench seat is split into two sections that are different sizes. Each section can be adjusted separately.

Adjusting the rear bench seat forward or backward



Fig. 60 Under the seat cushion in the rear bench seat: Adjusting lever.

1. Pull the right or left lever upward in the direction of the arrow *fig. 60* and slide the corresponding section of the rear bench seat forward or backward.
2. Release the lever and allow the section of the rear bench seat to engage by sliding slightly forward or backward.

Adjusting the rear seat backrest



Fig. 61 Left side area in the rear bench seat: adjusting lever.

The rear seat backrest can only be adjusted if the seat in question is occupied.

1. Pull the adjusting lever upward in the direction of the arrow *fig. 61*.
2. Allow the rear seat backrest to fold forward slightly.
3. Press the rear seat backrest back into the desired position.
4. Release the adjusting lever and allow the rear seat backrest to lock into place by pushing it slightly forward or back.

Adjusting the rear seat

📖 Please read the introductory information and heed the Warnings and Notice ⇒ ⚠️ and ⓘ *Introduction*.



Fig. 62 Adjusting the rear seat.

- ① **Only in the second row of seats:** Pull the lever to move the backrest into the required position. The seat backrest must lock into place after the lever is released. In the center seating position, instead of a lever, there is a loop (depending on the vehicle equipment). It works just like the lever.
- ② **Only in the second row of seats in six-seaters:** Press the button under the armrest to adjust the armrest.
- ③ **Only in the second row of seats:** Pull the lever to move the seat into the required position. The seat must lock into place after the lever is released.

⚠ NOTICE

If the backrest in the second row of seats is tilted back as far as it will go, this could damage a trunk cover that has been installed behind it.

- Remove the luggage compartment cover before adjusting the backrest.

Folding the second row seats into the cargo floor position

📖 Please read the introductory information and heed the Warnings and Notice ⇒ ⚠ and ⚠ *Introduction*. Each rear seat can be folded forward individually to increase the size of the luggage compartment.

A rear seat can only be folded over if the seat is not occupied.



Fig. 63 Second row seats: folding the outer rear seat forward into the cargo floor position.

Folding the second row seats into the cargo floor position

1. If necessary, open the belt buckle and guide the safety belt back by hand.
2. Fold up the armrests.
3. Slide the front seats forward.
4. Remove any objects from the footwell in front of and behind the rear seat ⇒ ⚠.
5. Move the rear seat all the way back.
6. Move the head restraints all the way down.
7. Pull the release lever *fig. 63* up and fold the rear seat backrest forward.

The entire rear seat will fold forward ⇒ ⚠.

8. Press down on the folded rear seat backrest until the backrest locks into the cargo floor position ⇒ ⚠.

Adults or children should not ride in the rear seat when it is folded forward ⇒ ⚠.

Folding the second row seats back

1. Fold the release lever *fig. 63* up and fold the rear seat backrest into the upright position.

The entire rear seat will fold back.

2. Pull on the rear seat and on the rear seat backrest to make sure the rear seat and the rear seat backrest are securely locked into place.

The red marking on the rear seat must no longer be visible ⇒ ⚠.

⚠ WARNING

Uncontrolled or unintentional folding of the rear seat backrests can cause serious injuries. If a seat is used without the backrest being locked in place, the passenger will move forward with the backrest in the event of sudden braking and driving maneuvers or a collision.

- Never fold the rear seat backrest forward or back while driving.
- Make sure the safety belt is not pinched or damaged when folding the rear seat backrest back.
- Keep hands, fingers, feet, and other parts of the body out of the range of operation of the seat hinges and seat locking mechanism when folding the backrest forward and back.
- Floor mats or other objects can become caught in the hinges on the rear seat backrest or seat. This can prevent the rear seat backrest or rear seat from locking when folded into the upright position.
- Each rear seat backrest must always be locked in the upright position to ensure that the safety belts in the rear seats can provide the maximum protection.
- Never allow people to sit in a rear seat if that rear seat backrest or the rear seat is folded forward or is not engaged.

NOTICE

Objects in the footwell in front of and behind the rear seats can be damaged when the rear seats are folded forward or back.



- Remove all objects before folding the seat forward or back.

NOTICE

When seats are folded forward, the head restraints or cushions on the rear seat backrests could cause damage to the front seat backrests.

- Before folding the rear seat backrest forward, adjust the front seats so that the head restraint or padding on the rear seat backrest does not press against the front seats.

Folding the third row seat into the cargo floor position

 Please read the introductory information and heed the Warnings and Notice  and  *Introduction*. Each rear seat can be folded forward individually to increase the size of the luggage compartment.

Folding the third row seats into the cargo floor position

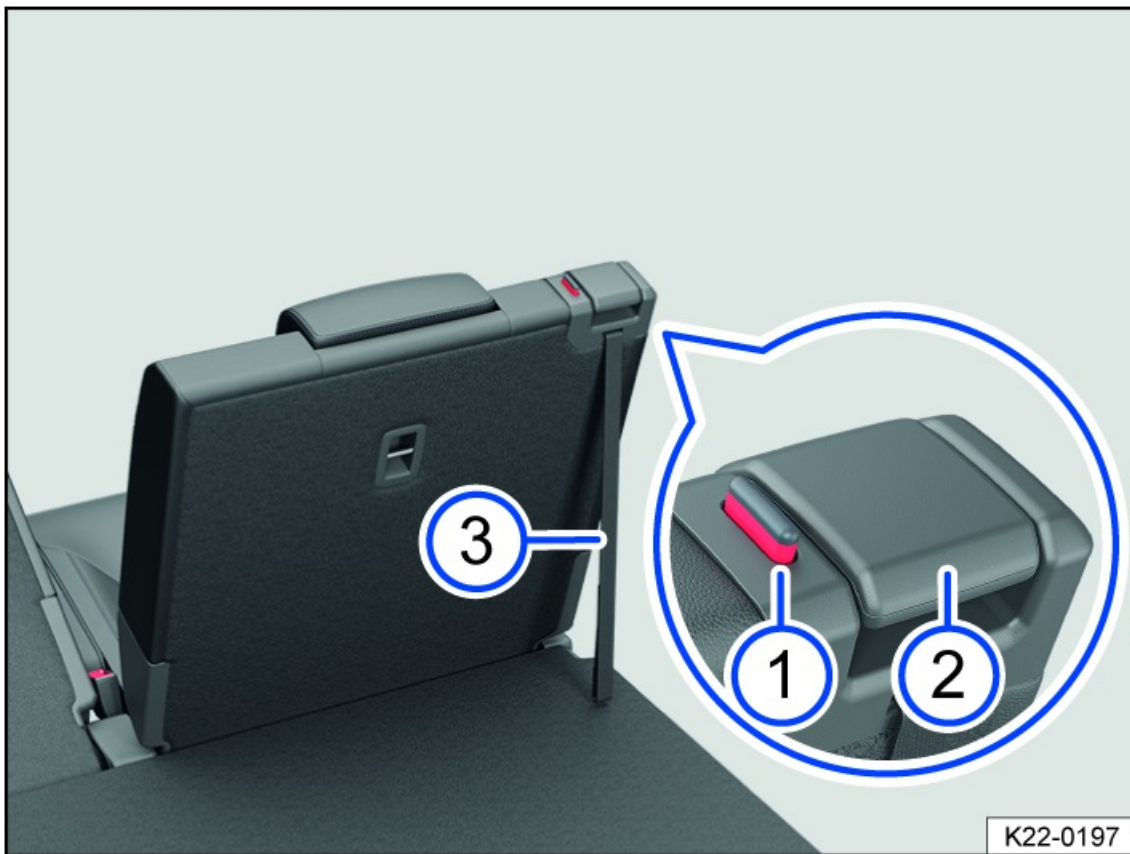

Fig. 64 Third row seat: folding the rear seat into the cargo floor position.

1. Open the trunk lid.
2. Remove the luggage compartment cover if necessary.
3. Move the head restraints all the way down.
4. To prevent damage to the seat and belt, remove the safety belt from both belt buckles.
5. Push the seats in the second row forward.
6. Remove any objects from the footwell in front of and behind the rear seat ⇒ ⚠.
7. Remove any objects from the seat well behind the rear seat.
8. To release the rear seat backrest, pull the release lever *fig. 64* all the way up.
9. Guide the rear seat backrest down by hand until it lies flat on the seat frame ⇒ ⚠.
Adults or children should not ride in the rear seat when it is folded forward ⇒ ⚠.
10. Close the trunk lid.

Folding the third row seats back

You can fold back the third row rear seats manually from the vehicle interior or with the loop from the luggage compartment.

1. Open the trunk lid.
2. Remove the luggage compartment cover if necessary.
3. Fold the rear seat backrest back from the passenger compartment by hand.

Or: to fold back the rear seat backrest from the luggage compartment area, pull on the loop on the rear seat backrest *fig. 64*.

The red marking on the release lever *fig. 64* must no longer be visible.

4. Pull and press on the folded-back rear seat backrest to make sure that it is latched in place ⇒ ⚠.
5. Install the luggage compartment cover again if necessary.

6. Close the trunk lid.

WARNING

Uncontrolled or unintentional folding of the rear seat backrests can cause serious injuries. If a seat is used without the backrest being locked in place, the passenger will move forward with the backrest in the event of sudden braking and driving maneuvers or a collision.

- Never fold the rear seat backrest forward or back while driving.
- Make sure the safety belt is not pinched or damaged when folding the rear seat backrest back.
- Keep hands, fingers, feet, and other parts of the body out of the range of operation of the seat hinges and seat locking mechanism when folding the backrest forward and back.
- Floor mats or other objects can become caught in the hinges on the rear seat backrest or seat. This can prevent the rear seat backrest or rear seat from locking when folded into the upright position.
- Each rear seat backrest must always be locked in the upright position to ensure that the safety belts in the rear seats can provide the maximum protection.
- A red marking on the release lever *fig. 64* indicates that the rear seat backrest is not latched. The red marking must not be visible when the backrest is latched.
- Never allow people to sit in a rear seat if that rear seat backrest or the rear seat is folded forward or is not engaged.

NOTICE

Objects in the footwell in front of and behind the rear seats can be damaged when the rear seats are folded forward or back.

- Objects in the seat well behind the third row seats can be damaged when the third row seats are folded forward or back. Remove any objects before folding the seat forward or back.
- Securing elements and cover mounts that are secured on the rail system can be damaged when the third row seats are folded forward or back, which can cause damage to the rear seats. Remove the securing elements and cover net mounts from the rail system before folding the seats forward or back.

 Depending on the vehicle equipment, there may be a symbol on the release lever.

Head restraints

Introduction

The information that follows describes how the head restraints can be adjusted and removed. Always make sure the seats are adjusted to the correct position ⇒ *Correct seating position*.

All seats are equipped with head restraints. The head restraints are specially approved for the relevant seat and should not be installed in another seat in the vehicle.

If a seat is occupied, select the correct head restraint setting for the respective head restraint. If a seat is not occupied, the respective head restraint can be pushed down as far as it will go.

The center rear head restraint (depending on the vehicle equipment) is only intended for the center seat on the rear bench seat. Therefore do not install this head restraint in any other position.

There are notches in the head restraint supports so that they can be locked in different positions. Only head restraints which

are correctly mounted can lock into the notches within the adjustable range. To prevent the head restraints from being removed unintentionally after mounting, there are stops at the top and bottom of the adjustable range.

Correct head restraint adjustment

Adjust the head restraint so that the upper edge of the head restraint is in line with the upper portion of the head as much as possible, but not lower than eye level. Position the back of the head as close as possible to the head restraint.

Head restraint adjustment for shorter persons

Slide the head restraint all the way down, even if the head is then below the upper edge of the head restraint. When the head restraint is in the lowest position, there may be a small gap between the head restraint and the backrest.

Head restraint adjustment for taller persons

Move the head restraint up all the way.

WARNING

Driving with head restraint that have been removed or adjusted incorrectly increases the risk of serious or fatal injuries in the event of an accident or sudden driving and braking maneuvers.



- If a person is sitting in a seat, always drive with the head restraint correctly installed and adjusted on that seat.
- If a person is sitting in a seat, adjust the head restraint according to their height.
- Never adjust the head restraint while driving.

NOTICE

Removing and fitting the head restraints incorrectly may cause damage.

- When removing and installing the head restraint, make sure the head restraint does not hit the headliner, the front seat backrest, or other vehicle components.

Adjusting the head restraints

 Please read the introductory information and heed the Warnings and Notice ⇒  and  *Introduction*.

Adjusting the height of the front head restraint

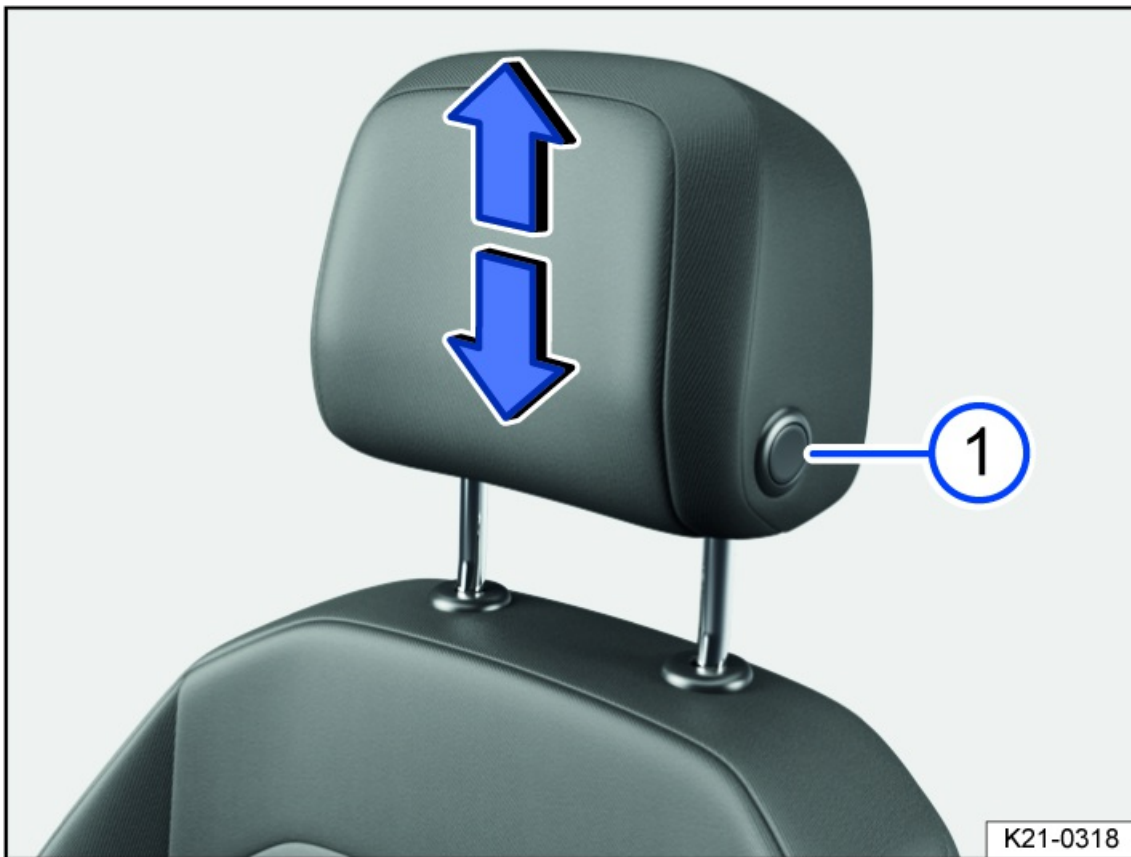

Fig. 65 Adjusting the front head restraint (general example).

1. If necessary, slide the head restraint upward or downward in the direction of the arrow and when pressing the button. *fig. 65*

The head restraint must lock securely into place.

Adjusting the height of the head restraints of the second row seats

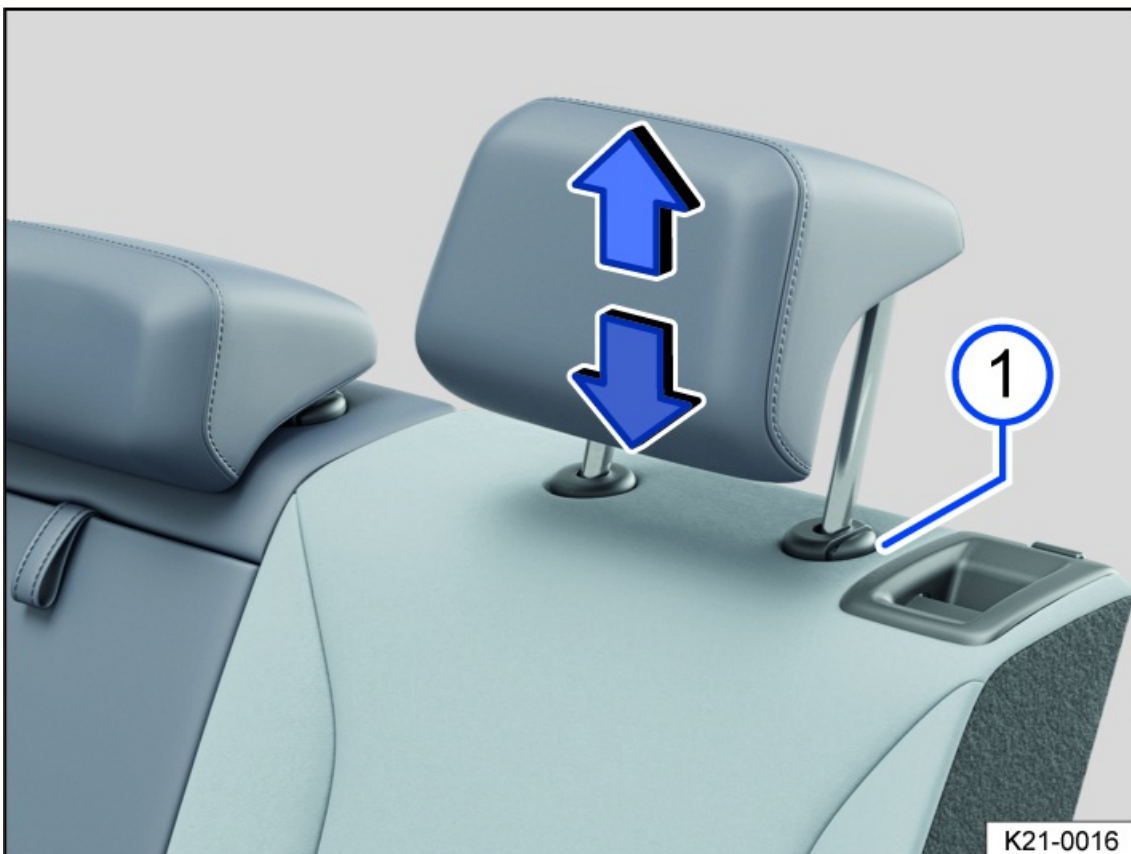

Fig. 66 Adjusting the head restraint on the second-row seats (general example).

1. Push the head restraint upward in the direction of the arrow or slide it downward while pressing the [fig. 66](#) button.

The head restraint must lock securely into place. There are two possible positions in the second row seats.

Adjusting the height of the head restraints of the third row seats

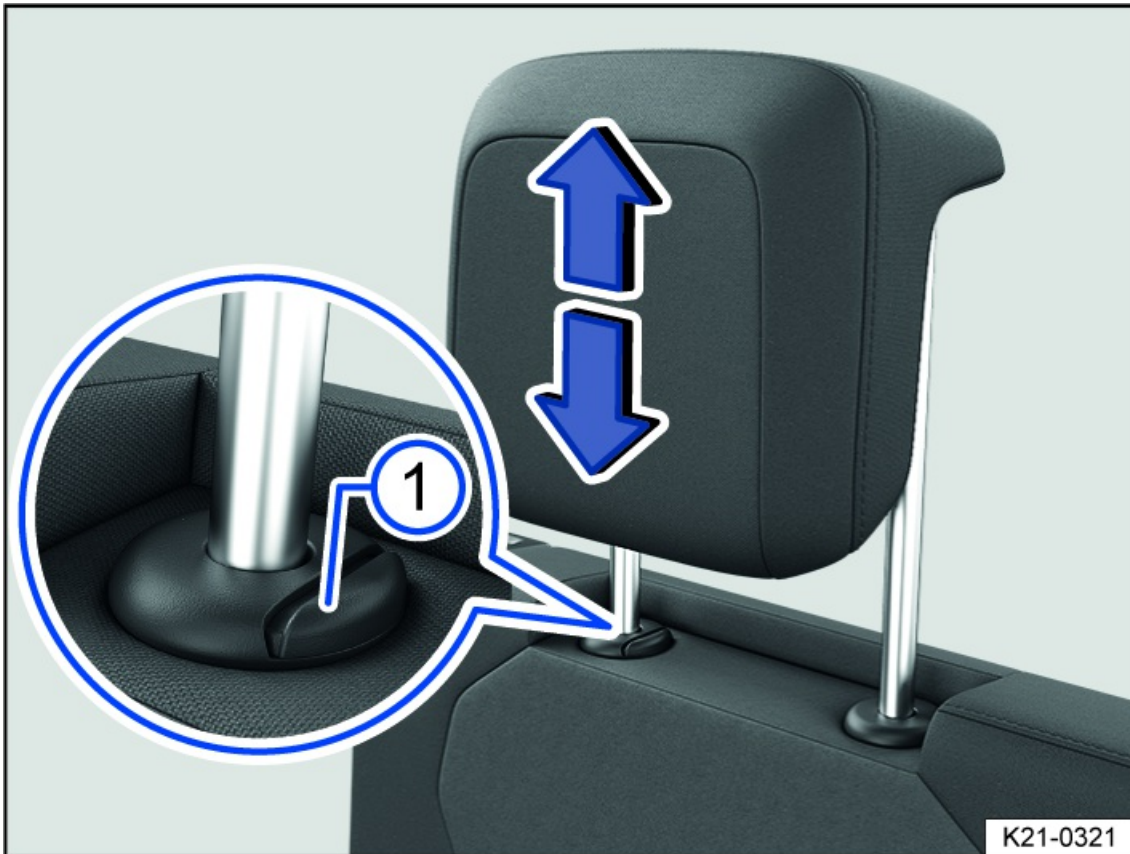

Fig. 67 Adjusting the head restraint on the third-row seats (general example).

1. Push the head restraint upward in the direction of the arrow or slide it downward while pressing the [fig. 67](#) button.

The head restraint must lock securely into place. There is one possible position in the third-row seats.

Removing and installing the head restraints

📖 Please read the introductory information and heed the Warnings and Notice ⇒ ⚠️ and ⚠️ Introduction.

Removing the front head restraints

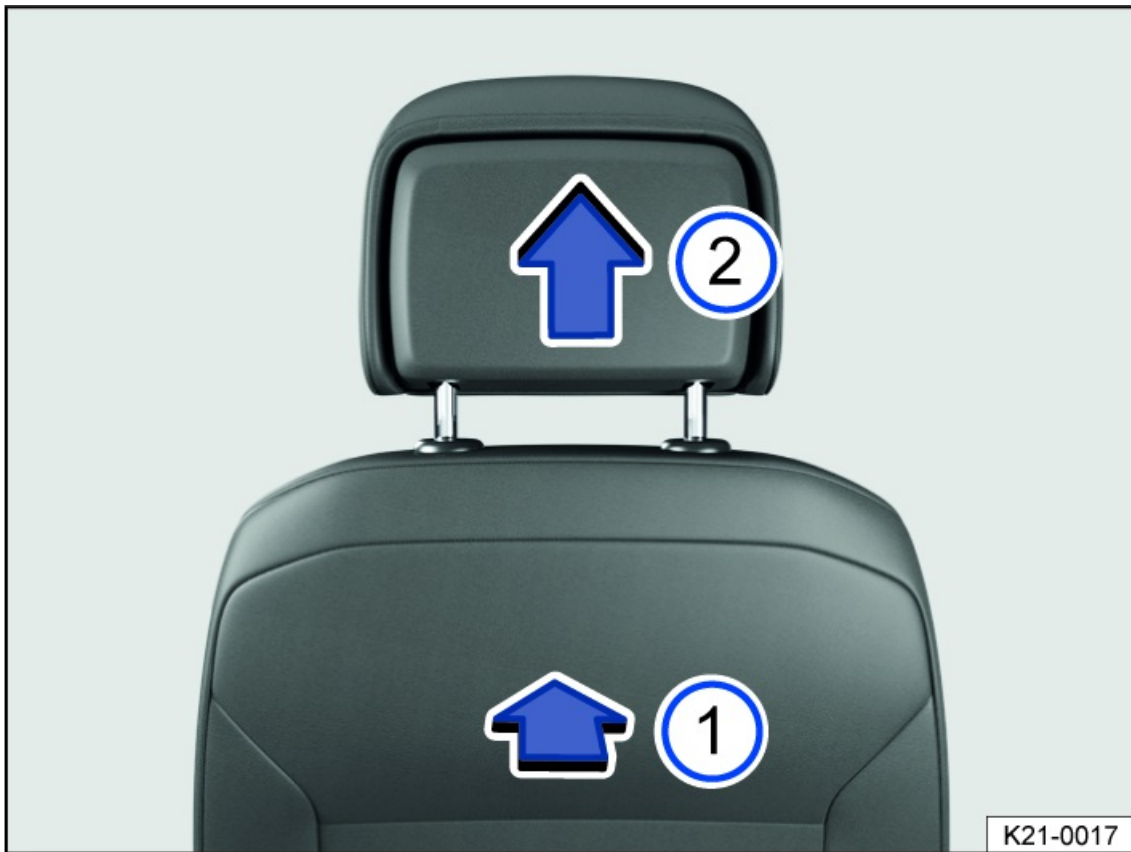

Fig. 68 Removing the front head restraint (general example).

1. Lower the head restraint if necessary.
2. To release, find the notch on the rear side in the marked area, push inwards in the direction of the arrow and hold *fig. 6*
3. Pull out the head restraint in the direction of the arrow *fig. 68*.

Installing the front head restraints

1. Position the head restraint correctly above the head restraint guides and insert into the guides on the seat backrest.
2. Slide the head restraint downward until it engages into the guide rods.
3. Adjust the head restraint to the correct position.

Removing the head restraint on the second-row seats

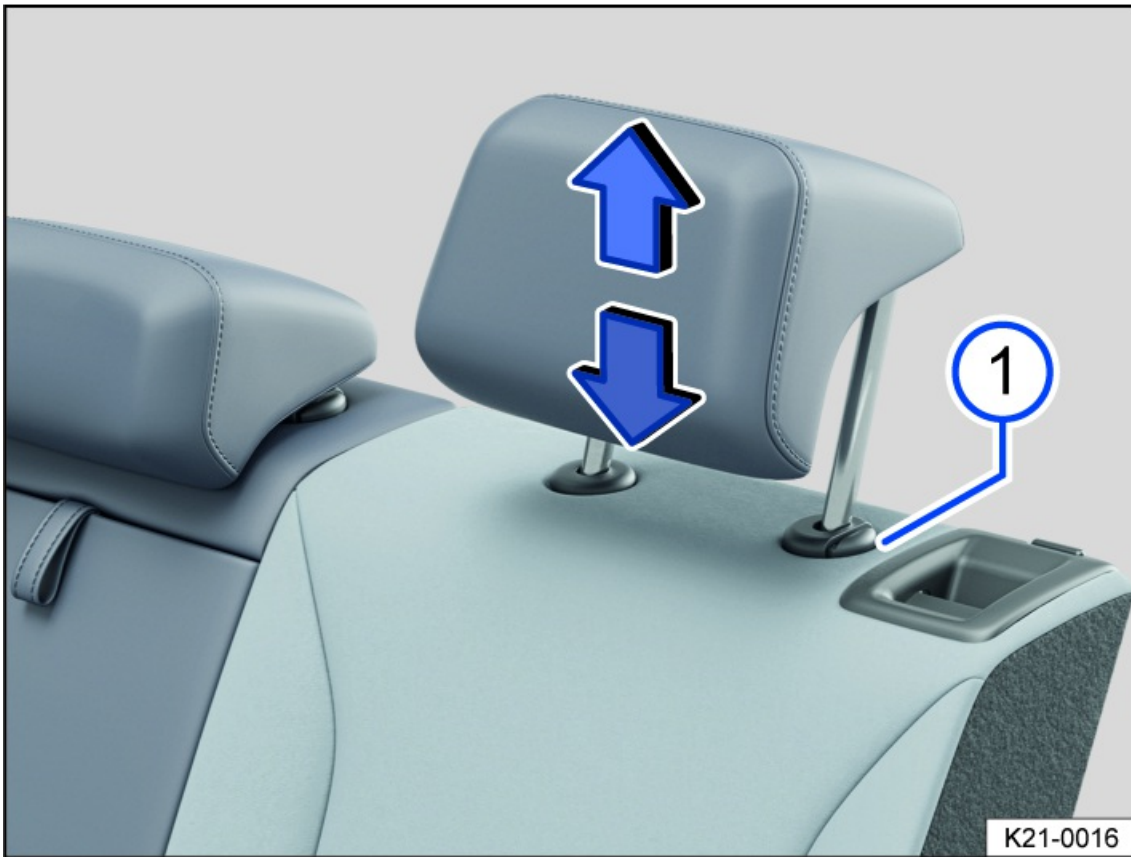

Fig. 69 Removing the head restraint on the second-row seats (general example).

1. If necessary, adjust the seat backrest so that the head restraint can be removed.
2. Slide the head restraint all the way upward.
3. Pull the head restraint all the way out while pressing the *fig. 69* button.
4. If necessary, fold the rear seat backrest toward the rear and lock it securely into place.

Installing the head restraint on the second-row seats

1. If necessary, adjust the seat backrest so that the head restraint can be installed.
2. Position the head restraint correctly above the head restraint guides and insert into the guides on the seat backrest.
3. Push the head restraint downward while pressing the *fig. 69* button.
4. If necessary, fold the rear seat backrest toward the rear and lock it securely into place.
5. Adjust the head restraint and the backrest to the correct seating position and let them lock into place.

Removing the head restraint on the third-row seats

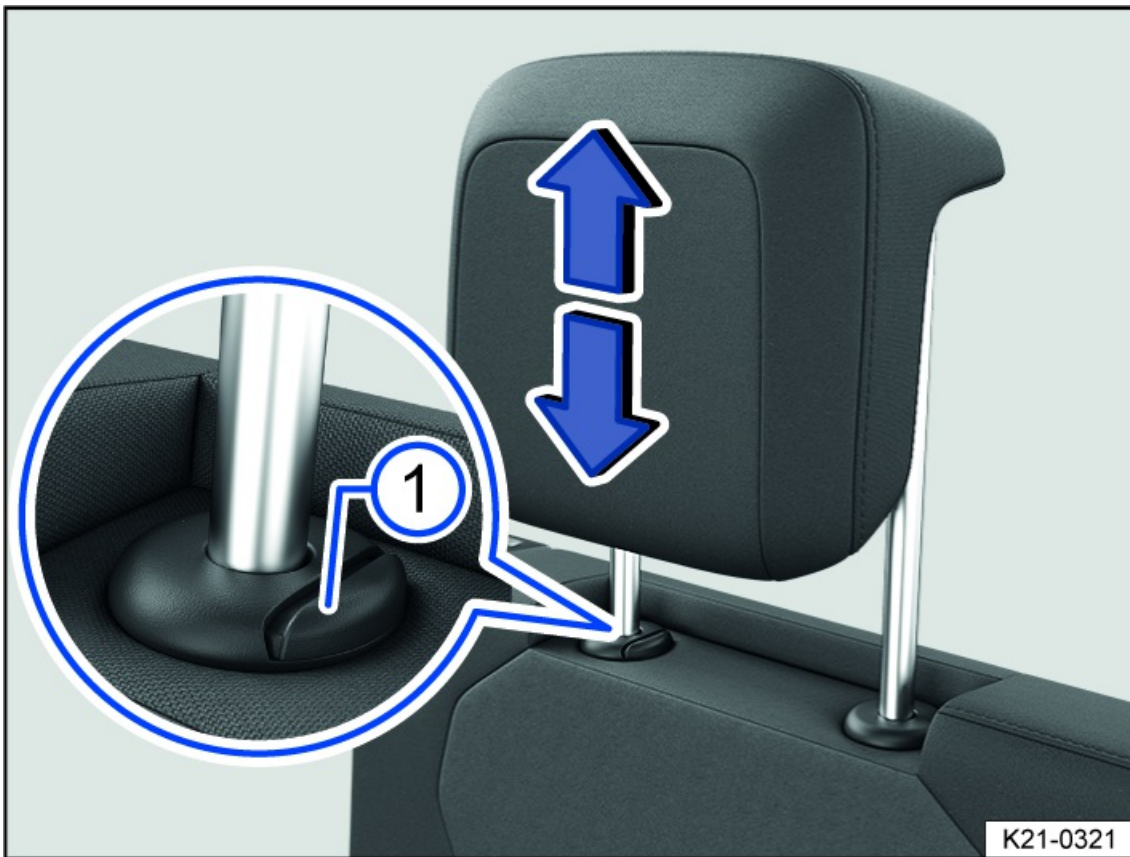

Fig. 70 Removing the head restraint on the third-row seats (general example).

1. If necessary, adjust the seat backrest so that the head restraint can be removed.
2. Slide the head restraint all the way upward.
3. Pull the head restraint all the way out while pressing the *fig. 70* button.
4. If necessary, fold the rear seat backrest toward the rear and lock it securely into place.

! NOTICE

If you fold the rear seat backrest of the third row of seats forward and their head restraints bump against the rear seat backrest of the second row of seats, the head restraints may be damaged.

- Push the seats in the second row forward before you fold the rear seat backrest of the third row of seats forward.

Installing the head restraint on the third-row seats

1. If necessary, adjust the seat backrest so that the head restraint can be installed.
2. Position the head restraint correctly above the head restraint guides and insert into the guides on the seat backrest.
3. Push the head restraint downward while pressing the *fig. 70* button.
4. Fold the rear seat backrest toward the rear and lock it securely into place.
5. Adjust the head restraint and the backrest to the correct seating position and let them lock into place.

Seat functions

Center armrest

Front center armrest



Fig. 71 Front center armrest (general example).

There is a storage compartment under the center armrest.

⚠ WARNING

If the front center armrest is opened all the way or not completely closed, it can limit the driver's ability to move his or her arms, which can cause accidents and serious injuries.

- Always keep the storage compartments closed while driving.
- Never allow an adult or child to ride on the center armrest. This incorrect seating position can cause serious injuries.

Rear center armrest



Fig. 72 In the backrest of the center seat: folding rear center armrest.

For six-seaters: The armrest can be adjusted separately ⇒ *Adjusting the rear seat*.

There may be a folding center armrest in the backrest of the middle seat of the rear bench seat.

- To fold forward: pull the center armrest in the direction of the arrow using the loop *fig. 72*.
- To fold back: fold the center armrest upward in the opposite direction of the arrow *fig. 72* and press it all the way toward the seat backrest.

Passengers must not sit in the center rear seat when the center armrest is folded down.

⚠ WARNING

Incorrect use of the rear center armrest may cause serious injuries.

- If the center armrest is folded down, the center rear bench seat must never be used by either adults or children.
- Never allow an adult or child to ride on the center armrest.

⚠ WARNING

Objects that are not secured or are secured incorrectly in the rear center armrest may be thrown around during sudden braking or driving maneuvers and can cause serious injuries.

- Store objects such as drinks in the storage compartments provided ⇒ *Introduction*.

ⓘ NOTICE

Incorrect handling of the rear center armrest can cause damage to the seat and the center armrest.

- Remove all objects before folding back the rear center armrest.

Third row seat entry assistance

To make it easier to enter and exit the third row seats in vehicles with seven seats, the outer seats in the second row can be folded forward.

Folding second row seats forward



Fig. 73 Second row seats: entry assistance controls.

1. Remove any objects from the footwell in the second row of seats ⇒ ⚠.
2. Move the head restraints all the way down.
3. Push the release lever *fig. 73* forward in the direction of the arrow until the red marking is fully visible.
4. Fold the rear seat backrest forward.

The entire rear seat will fold forward and can be moved forward more ⇒ ⚠.

5. Enter and exit carefully ⇒ ⚠.

Folding the second row seats back

1. Move the rear seat all the way back.
2. Pull the release lever *fig. 73* and fold the rear seat backrest back into the upright position.

The entire rear seat will fold back ⇒ ⚠.

The rear seat must be latched securely. If the red marking on the lever *fig. 73* is still visible, the rear seat is not securely engaged.

Third row seat emergency exit function

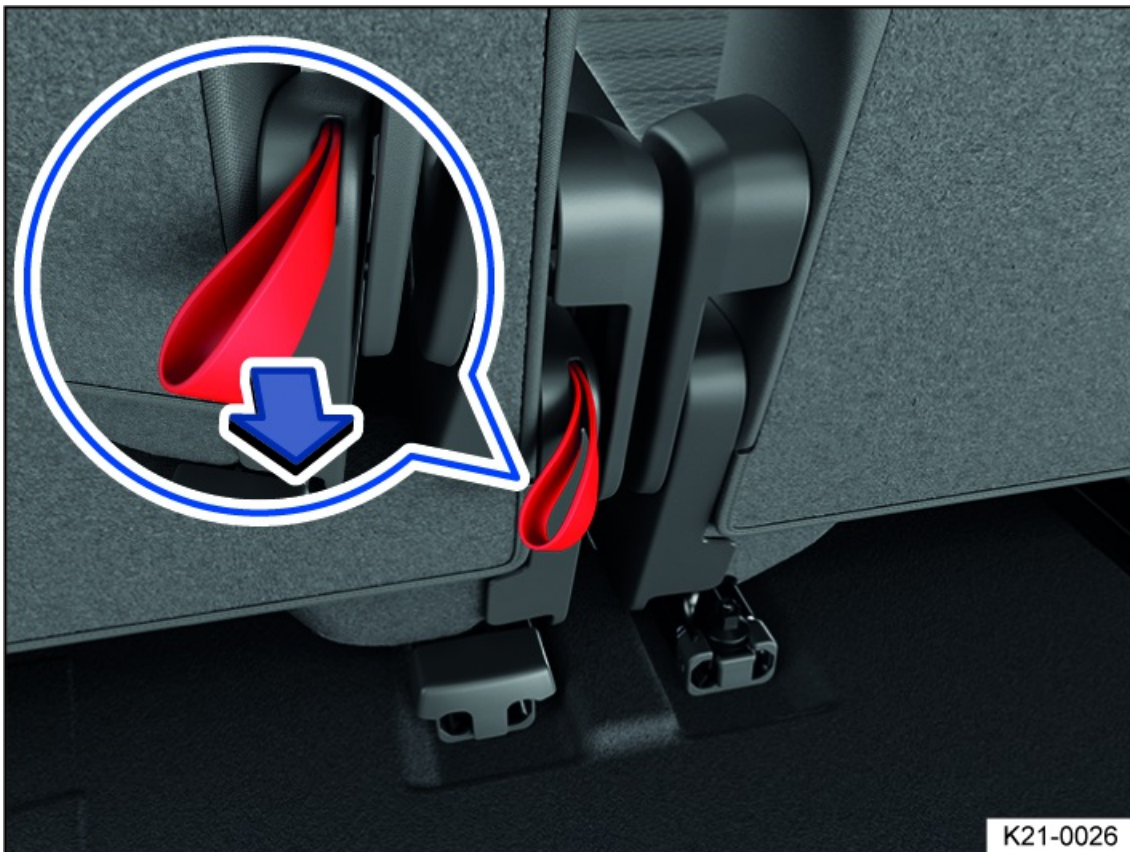

Fig. 74 Second row seats: loop for third row seat emergency exit function.

If the release lever *fig. 73* is not working, for example after a collision, the seats in the second row can be folded forward by someone in the third row to make it easier to exit the third row ⇒ ⚠.

1. Pull the loop *fig. 74* back and fold the rear seat backrest forward.

The entire rear seat will fold forward .

⚠ WARNING

Careless or unmonitored use of the entry assistance and the loop for the emergency exit function can result in accidents and serious injuries. If a seat is used without the backrest being locked in place, the passenger will move forward with the backrest in the event of sudden braking and driving maneuvers or a collision.

- Never use the entry assistance or the loop for the emergency exit function while driving.
- Ensure that the safety belt is not pinched or damaged when folding the rear seats back.
- Keep hands, fingers, feet, and other parts of the body out of the range of operation of the seat hinges and seat locking mechanism when folding the backrest forward and back.
- Floor mats or other objects can become caught in the hinges on the rear seat backrest or seat. This can prevent the rear seat backrest or rear seat from latching when folded into the upright position.
- Each rear seat backrest must always be locked in the upright position to ensure that the safety belts in the rear seats can provide the maximum protection.
- A red marking on the release lever *fig. 73* indicates that the rear seat backrest is not latched. The red marking must not be visible when the backrest is latched.
- Never allow people to sit in a rear seat if that rear seat backrest or the rear seat is folded forward or is not securely engaged.
- Never hold onto a folded-down seat in the second row of seats or support yourself on this when entering or exiting the vehicle.

⚠ WARNING

If child restraints are installed in all of the second row seats, it may not be possible for someone in the third row to fold the second row seats forward in the event of an accident. Passengers sitting in the third row seats will not be able to exit the vehicle by themselves or help themselves in an emergency.

- Never install child restraints on all seats in the second row if any passengers will be riding in the third row.

ⓘ NOTICE

When seats are being folded forward or back, the head restraints or cushions on the rear seat backrests could cause damage to the front seat backrests.

- Before folding the rear seat backrests forward or back, adjust the front seats so that the head restraints or cushions on the rear seat backrests do not bump against the front seats.

ⓘ NOTICE

Objects in the footwell in the second row can be damaged when the rear seat is folded forward.

- Before folding down the rear seat, remove any objects that may be present.

 Depending on the vehicle equipment, there may be a symbol on the release lever.

Memory function

Memory buttons

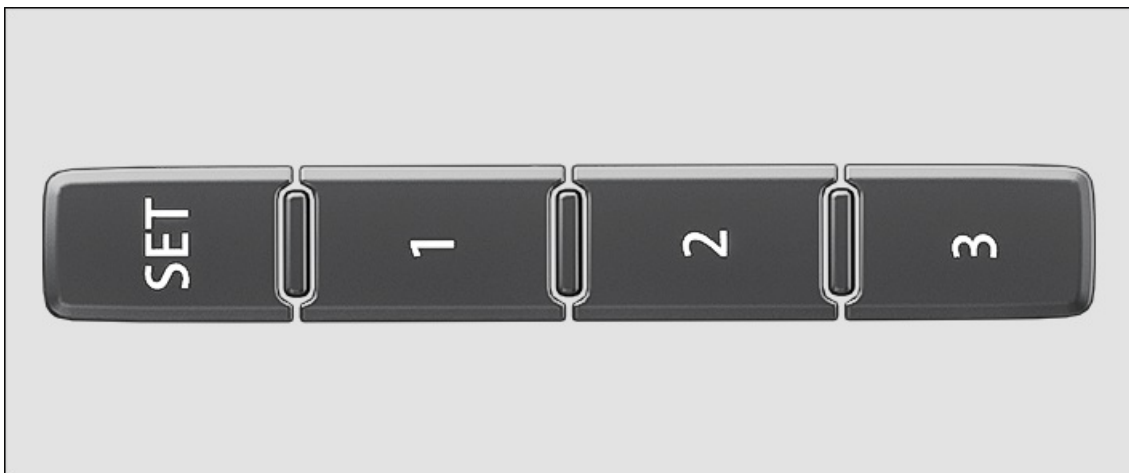

Fig. 75 On the outer side of the driver's seat: memory buttons.

The driver seat and outside mirror settings can be saved and opened using the memory buttons.

Storing the driver's seat and outside mirror settings for driving forward

1. Set the electronic parking brake.
2. Shift the transmission to neutral.
3. Switch the ignition on.
4. Adjust the driver's seat and outside mirror.

5. Press and hold the **SET** button *fig. 75* for longer than one second.
6. Press the desired memory button *fig. 75* within approximately 10 seconds.

A chime will confirm that the settings were saved.

Storing the front passenger's outside mirror settings for driving in reverse

1. Set the electronic parking brake.
2. Shift the transmission to neutral.
3. Switch the ignition on.
4. Press the desired memory button *fig. 75*.
5. Select the reverse gear.
6. Adjust the front passenger's outside mirror so that the edge of the curb can be seen clearly, for example.

The selected mirror position will be stored automatically and assigned to the vehicle key that was used to unlock the vehicle.

Opening the driver seat and outside mirror settings

1. When the vehicle is stationary, the ignition is switched off, and a door is open, press the respective memory button briefly.

After approximately ten minutes, the stored positions can no longer be adjusted automatically. The adjustment process will be canceled if one of the memory buttons is pressed again.

Or: When the ignition is switched on or the door is closed, press and hold the respective memory button until the saved positions are reached.

The front passenger's outside mirror automatically leaves the position stored for driving in reverse once you begin driving forward at speeds of at least approx. 15 km/h (approx. 10 mph) or when you turn the knob for the outside mirrors from the **R** position to another position.

 If you open the driver door more than approximately ten minutes after the vehicle is unlocked, the driver seat and the outside mirrors will not be adjusted automatically.

Front seat convenience entry function

When you open the driver door, the driver seat automatically moves to a position that enables you to enter and exit the vehicle with ease.

The driver seat automatically returns to its original position once you have closed the driver door and switched on the ignition.

The front seat convenience entry function can be enabled and disabled in the Infotainment system .

WARNING

Improper use of seat functions can cause injuries.

- Before beginning a journey always adjust to the correct seat position and maintain this throughout the journey. This also applies to all passengers.
- Set the memory function only with the vehicle stationary.
- Always keep your hands, fingers, feet and other parts of your body clear of the area in which the seats operate and move during adjustment.

¹⁾ Only if personalization has been activated.

Massage feature



Fig. 76 Massage function button to the side of the driver seat.

Depending on the vehicle equipment, for the massage function, the lumbar support moves and massages the lumbar area of your back.

The lumbar support cushioning can be individually adjusted during operation by pressing repeatedly on the corresponding switch ⇒ *Adjusting power front seats*.

Switching the massage function on or off

1. To switch on, push the  button in the seat control panel. Press the  button again to switch off.

After around ten minutes, the massage function switches off automatically.

WARNING

Improper use of seat functions can cause injuries.

- Before beginning a journey always adjust to the correct seat position and maintain this throughout the journey. This also applies to all passengers.
- Only switch the massage function on and off when the vehicle is stationary.
- Always keep your hands, fingers, feet and other parts of your body clear of the area in which the seats operate and move during adjustment.

Lights

Exterior lighting

Switching the turn signals on and off

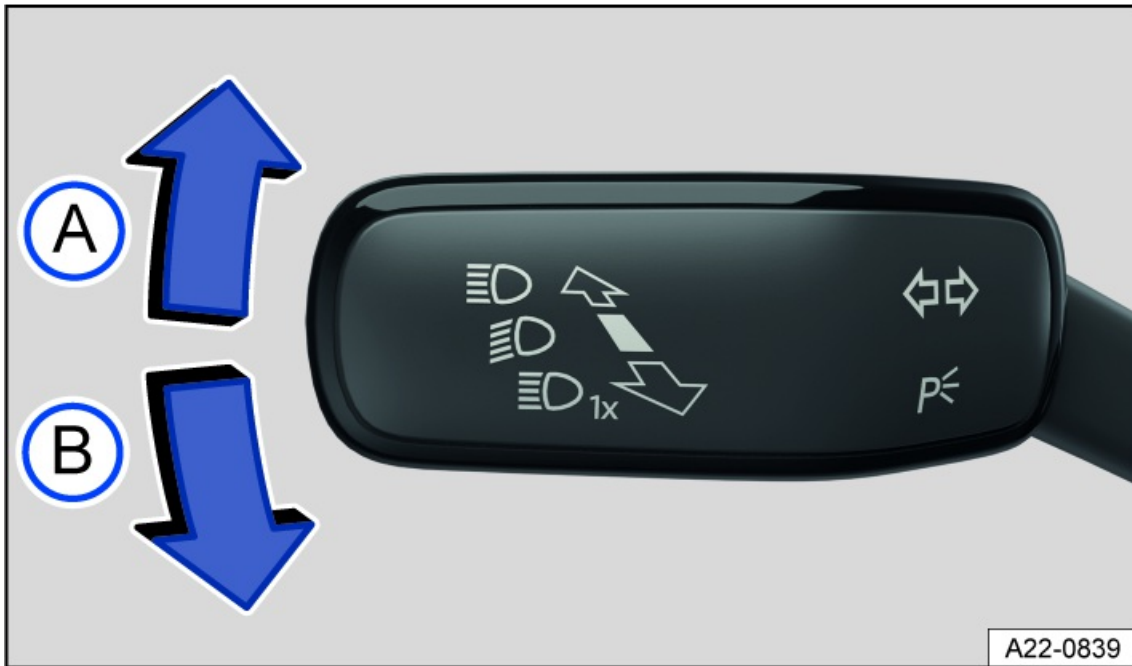

Fig. 77 On the left side of the steering column: turn signal and high beam lever.

- A Right turn signal ➔.
- B Left turn signal ➜.

Switching the turn signals on and off

1. Switch the ignition on.
2. Move the lever out of the center position into the desired position *fig. 77*.
3. To cancel the turn signal, move the lever back to its basic position.

If no chime sounds when the turn signal is on, contact suitably qualified professionals and have the vehicle checked. Volkswagen recommends contacting an authorized Volkswagen dealer or authorized Volkswagen Service Facility.

3-blink turn signal

1. Move the lever upward or downward to the pressure point and then release the lever.
The turn signal will blink three times.

To stop the 3-blink turn signal before it ends, move the lever immediately to the pressure point in the opposite direction and release.

The 3-blink turn signal can be activated and deactivated in the vehicle settings in the Infotainment system ⇒ *Vehicle settings menu*.

⚠ WARNING

Using the turn signals incorrectly, not using the turn signals, or forgetting to turn the turn signal off can mislead other road users. This can cause accidents and serious or fatal injuries.

- Always activate the turn signals correctly when changing lanes, passing, or turning.

- Switch the turn signal off again every time you finish changing lanes, passing, or turning.

 The emergency flashers also work when the ignition is switched off.

Switching the lights on and off





Fig. 78 Next to the steering wheel: Button to switch on the exterior lighting.

Switching the lights on

1. Switch the ignition on.
2. Tap the  function key repeatedly until the corresponding indicator lights come on.

 The low beam headlights are switched on. The green indicator light turns on.

AUTO Automatic headlights: The low beam headlights are switched on or off depending on the ambient brightness , \Rightarrow *Automatic headlight control*.

 Parking light and daytime running light switched on; the green indicator light comes on. The automatic headlights are activated from a speed of approximately 10 km/h (approximately 6 mph) or after a distance driven of around 100 m (approximately 328 ft) **AUTO**.

-- Only shown on the instrument cluster display: a message appears indicating that the light is switched off. The automatic headlights are activated from a speed of approximately 10 km/h (approximately 6 mph) or after a distance driven of around 100 m (approximately 328 ft) **AUTO**.

Switching the lights off

1. Switch the ignition off.

AUTO The orientation lighting can be switched on \Rightarrow *Entry and exit lighting (orientation lighting)*.

 The parking light is switched on \Rightarrow *Parking lights*. The green indicator light turns on.

-- Only shown on the instrument cluster display: a message appears indicating that the light is switched off.

Daytime running lights

The daytime running lights can increase the visibility of your vehicle in traffic during the daytime.

When the ignition is switched on, the daytime running light switches on (when brightness is detected).

Daytime running lights parking function

Depending on the equipment, the vehicle may have a daytime running lights parking function to turn off the daytime running lights temporarily when the ignition is switched on.

Switch off the daytime running lights:

1. Switch the ignition on.
2. Switch the lights off.
3. Set the electronic parking brake.

Switch on the daytime running lights:

1. Switch off the electronic parking brake.

NOTICE

If the outside temperature is very low, ice can form on the headlights. Improper cleaning can cause vehicle damage.

- Never use cleaning objects that are too hard or abrasive.
- Defrost the ice with a suitable deicer or Volkswagen Genuine deicer.

WARNING

If the vehicle lighting is not used appropriately for the weather conditions, the road will not be illuminated sufficiently. The vehicle will not be visible to other road users or will be difficult to see. This can cause accidents and serious or fatal injuries.

- Always turn on the low beam headlight in the dark, when it is raining, and when visibility is poor.
- Regularly check that the lighting system and turn signals are functioning correctly.

WARNING

The parking lights or daytime running lights are not bright enough to illuminate the road sufficiently and to be seen by other road users. The taillights do not switch on with the daytime running lights. The vehicle may not be seen by other road users in the dark, in the fog, and when visibility is poor if its taillights are not turned on. This can cause accidents and serious or fatal injuries.

- Always turn on the low beam headlight in the dark, when it is raining, and when visibility is poor.

WARNING

The automatic headlights **AUTO** support the driver. The driver is responsible for switching on the vehicle lighting correctly. The automatic headlights **AUTO** turn the dipped beam headlights on and off when there are changes in brightness. Insufficient lighting on the road may cause accidents and serious or fatal injuries.

- Turn on the low beam headlights manually in certain weather conditions, such as in fog.

 When reverse gear is engaged, the cornering lights on both sides of the vehicle will turn on automatically to better illuminate the surroundings while maneuvering.

Switching the high beam headlights on and off

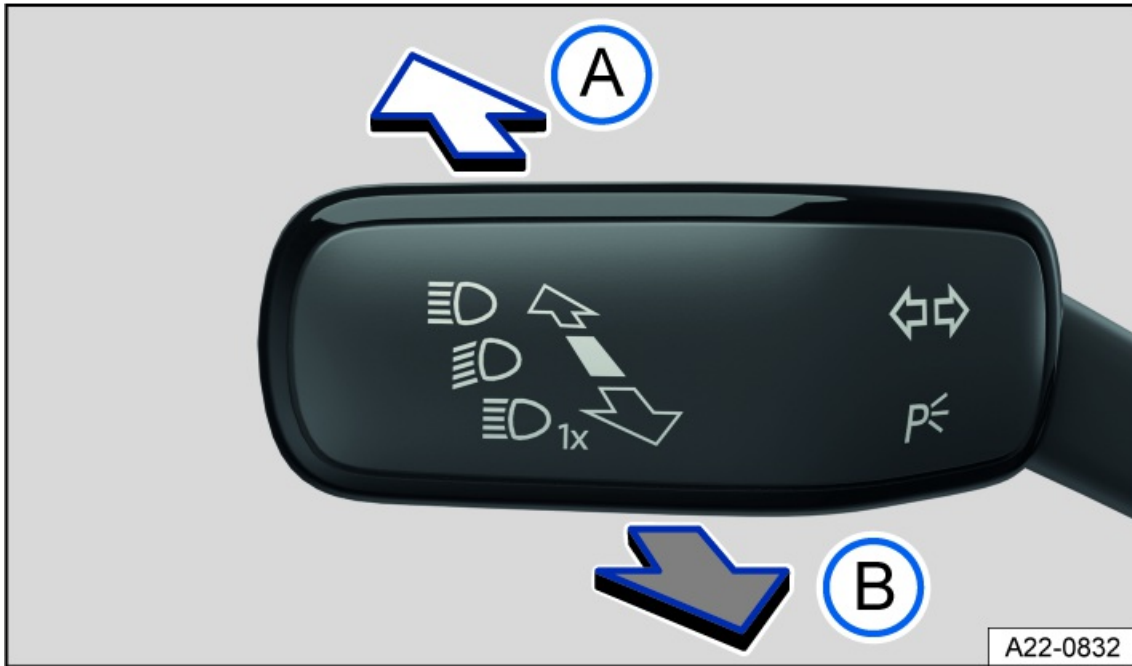





Fig. 79 On the left side of the steering column: turn signal and high beam lever.

A  Turn on the high beam headlight.

B Activate the headlight flashers or turn off the high beam headlights.

If the high beam headlights or headlight flashers are turned on, the blue  indicator light will come on in the instrument cluster ⇒ .

Turning on the high beam headlight

1. Switch the ignition on.
2. Switch on the low beam headlight.
3. Press the turn signal and high beam lever forward out of the center position *fig. 79*.

Turning off the high beam headlight

1. Pull the turn signal and high beam lever backward out of the center position *fig. 79*.

Turning the headlight flasher on and off

1. Pull the turn signal and high beam lever backward out of the center position and hold it *fig. 79*.

Release the turn signal and high beam lever to turn the headlight flasher off.

High beam assistance

Depending on the vehicle equipment, an automatic high beam assistance may be available → page , *High beam assistance (Light Assist)*.

WARNING

Incorrect use of the high beam headlight may distract and blind other road users. This can cause accidents and serious or fatal injuries.

- Use the high beam headlights only if other road users cannot be distracted or blinded.

High beam assistance (Light Assist)

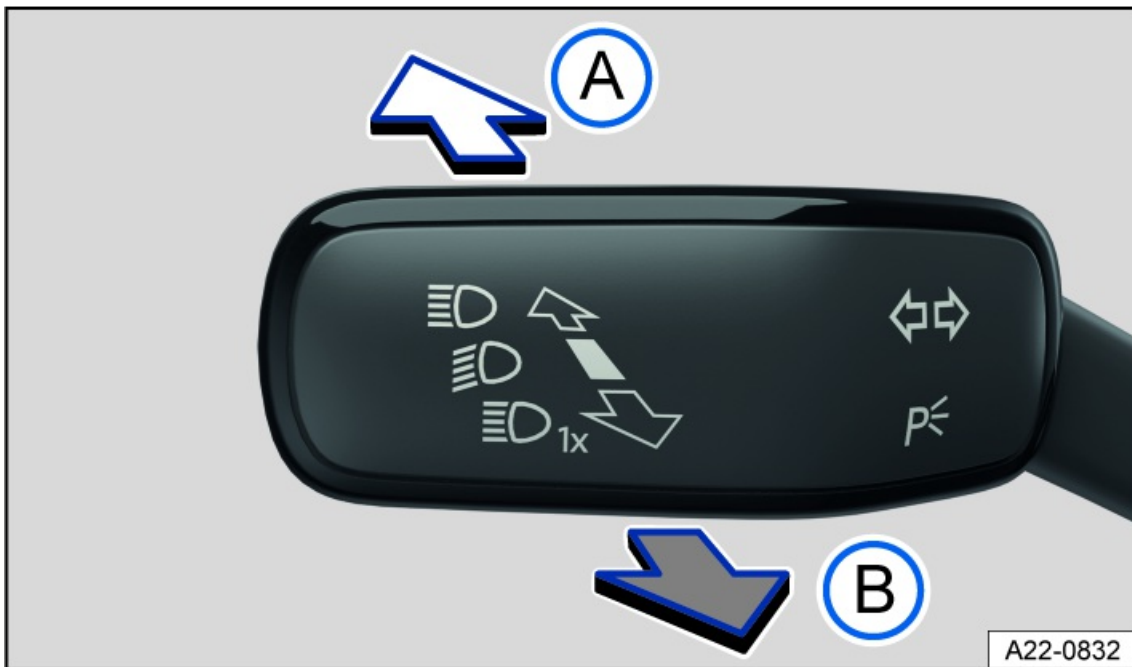

Fig. 80 On the left side of the steering column: turn signal and high beam lever.

The high beam assistance (Light Assist) automatically dims if oncoming vehicles or vehicles ahead are detected. In addition, Light Assist generally detects well-lit areas such as towns and deactivates the high beam headlights when driving through these areas.

The high beam headlights switch on and off automatically within the limits of the system, depending on the environmental and traffic conditions and the vehicle speed ⇒ ⚠.

☞ Switching on high beam control (Light Assist)

1. Switch the ignition on.
2. Switch on the automatic headlights **AUTO** ⇒ *Switching the lights on and off*.
3. Tap the lever forwards out of the basic position *fig. 80*.

When high beam control (Light Assist) is activated, the white ☞ indicator light comes on in the instrument cluster display. If high beam control (Light Assist) is switched on, the blue ☞ indicator light for the high beam headlights will light up on the instrument cluster display.

Adjusting the sensitivity of Light Assist

Depending on the country, the sensitivity of Light Assist can be set in two stages:

- *Increase sensitivity*: push the lever forwards out of the starting position and hold it in place for approx. 15 seconds *fig. 80*.

The indicator light ☞ in the display of the instrument cluster will blink three times to confirm that this has been applied.

- *Reset sensitivity to standard setting*: push the lever forwards out of the starting position and hold it in place for approx. 15 seconds *fig. 80*.

The indicator light ☞ in the display of the instrument cluster will blink three times in quick succession to confirm that this has been applied.

Switching off high beam control (Light Assist)

1. Switch off the automatic headlights **AUTO** ⇒ *Switching the lights on and off*.

Or: if high beam control (Light Assist) is switched on and active, pull the lever backwards *fig. 80*.

Or: if high beam control (Light Assist) is switched on and is not active, press the lever forwards *fig. 80*. The manual high

beam headlights are now switched on. To switch off the manual high beam if necessary, pull the lever backwards .

System limitations

The high beams must be switched off manually in the following situations, because Light Assist may not switch them off at the right time or at all:

- In poorly lit towns which cannot be recognized as a town by the system.
- On poorly lit roads with strongly reflective signs.
- If there are others on the road who have inadequate lighting, such as pedestrians or cyclists.
- If there is cross traffic at perpendicular intersections.
- On tight curves where the view of traffic is partially obstructed, on steep rises, or in dips.
- When there are oncoming vehicles on roads with a center barrier and the drivers in the oncoming vehicle can clearly see above the barrier, for example truck drivers.
- In fog, snow, and heavy rain.
- When there are dust and sand in the air.
- If the windshield is damaged in the camera's field of vision.
- If the camera visual field is fogged over, dirty, or covered by a sticker, snow, or ice.
- If the camera switches off automatically due to a high ambient temperature or exposure to direct sunlight for a prolonged period. Light Assist will be available once the camera is available again.
- If the camera is faulty and the power supply is interrupted.

WARNING

Light Assist may not detect all traffic situations correctly and the function may be restricted in certain situations. Light Assist supports the driver. The driver is responsible for switching on the vehicle lighting correctly. Switching on the high beam headlight at the wrong time may distract and blind other road users. This can cause accidents and serious or fatal injuries.

- Always control the headlights yourself and adapt them to the lighting, visual, and traffic conditions.
- Switch the high beam off manually if it could blind other road users.

WARNING

If the camera lens is dirty, covered, or damaged, the Light Assist function may be limited. This is also the case if the vehicle lighting system is changed, such as by adding auxiliary headlights. This can cause accidents and serious or fatal injuries.

- Regularly clean the camera view area and keep it free of snow and ice.
- Do not cover the camera view area.
- Regularly check the windshield for damage in the camera lens area.

Dynamic cornering light

The dynamic cornering lights provide optimum illumination of the roadway.

The dynamic cornering light only works when the automatic headlights **AUTO** are switched on and at speeds of more than approximately 10 km/h (approximately 6 mph).

The dynamic cornering light can be activated and deactivated in the vehicle settings in the Infotainment system ⇒ [Vehicle settings menu](#).

Switching the poor weather lights on and off

Poor weather lights help you to illuminate the carriageway more effectively when visibility is poor.

The poor weather lights can only be switched on when the ignition is switched on.



Switching on the Poor Weather Lights

1. Switch the ignition on.
2. Tap the  button ⇒ [Switching the lights on and off](#).

The green indicator light in the button turns on. The  indicator light will also light up on the instrument cluster display for a few seconds.

Switching off the Poor Weather Lights

1. Tap the  button again.

 If the poor weather lights are switched on when the light is off, the parking lights are switched on ⇒  or the automatic headlights **AUTO** are switched on, the low beam headlights will also be switched on, regardless of the ambient brightness.

Troubleshooting



Turn signal indicator light

The green indicator light blinks.

If a turn signal light on the vehicle is not working, the indicator light will blink twice as fast.

1. Check the lights and replace any bulbs as necessary ⇒  [Exterior lighting using LED technology](#).
2. If the malfunction persists, contact a suitably qualified professional. Volkswagen recommends contacting an authorized Volkswagen dealer or authorized Volkswagen Service Facility.



Trailer turn signal indicator light

The green indicator light blinks.

If a trailer turn signal or the entire trailer light system is out, the indicator light will turn off.

1. Check the lights and replace any bulbs as necessary ⇒  [Exterior lighting using LED technology](#).
2. If the malfunction persists, contact a suitably qualified professional. Volkswagen recommends contacting an authorized Volkswagen dealer or authorized Volkswagen Service Facility.



Exterior lighting malfunction

The yellow indicator light turns on.

The headlights have completely or partially failed.

1. Check the lights and replace any bulbs as necessary ⇒  [Exterior lighting using LED technology](#).
2. If the malfunction persists, contact a suitably qualified professional. Volkswagen recommends contacting an authorized Volkswagen dealer or authorized Volkswagen Service Facility.



Rain/light sensor malfunction

The yellow indicator light turns on.

If the automatic headlights (**AUTO**) are switched on, the vehicle lighting will not turn on or off automatically.

1. Switch the ignition off and on.
2. If the malfunction persists, contact a suitably qualified professional. Volkswagen recommends contacting an authorized Volkswagen dealer or authorized Volkswagen Service Facility.

Dynamic cornering light

The swinging behavior of the bulbs can be influenced by the selected driving mode in vehicles with driving mode selection.

If the dynamic cornering light malfunctions, this is indicated on the instrument cluster display. Contact a suitably qualified professional. Volkswagen recommends contacting an authorized Volkswagen dealer or authorized Volkswagen Service Facility.

Controls are responding differently than expected

Moisture, dirt and grease may limit the functioning of the controls.

1. Always keep the control panels clean and dry.

Light Assistants Are Not Responding as Expected

Travel mode deactivates the dynamic cornering light.

1. Ensure that the travel mode is not activated when it is not required ⇒ [Vehicle settings menu](#).

Parking lights

Parking lights

Parking lights

If the parking light  is switched on, the parking light will come on at the front on both sides, sections of the taillights and the license plate light will come on at the rear and various buttons in the vehicle interior will come on.

Automatic parking light deactivation

The vehicle detects that the 12 V vehicle battery is low and switches off the parking light early enough to ensure that the engine can still be started, but not until at least two hours have passed.

If the battery capacity is not sufficient for the parking light to run for two hours, the 12 V vehicle battery may drain to such an extent that the engine can no longer be started.

WARNING

If the vehicle is stopped without enough lighting and cannot be seen or is difficult for others on the road to see, this can cause accidents and serious or fatal injuries.

- Always stop the vehicle safely and with enough lighting.
- Follow the country-specific legal regulations.

Entry and exit lighting (orientation lighting)

When you are entering and exiting the vehicle in the dark, the entry and exit lighting illuminates the immediate area around the vehicle.

The entry and exit lighting is automatically controlled by a light sensor.

Switching on entry lighting

1. Unlock the vehicle if the automatic headlights **AUTO** are switched on and the light sensor detects *darkness*.

Switching off entry lighting

1. Turns off automatically after the set lighting time has elapsed.

Or: Lock the vehicle.

Or: Press the  button repeatedly until the **OFF** setting is displayed in the instrument cluster.

Or: Switch on the ignition.

Switching on exit lighting

1. Switch the ignition off.

The exit lighting switches on when the automatic headlights **AUTO** are switched on and the light sensor detects *darkness*.

The *lighting time* begins when the last vehicle door or trunk lid is closed.

Switching off exit lighting

1. Turns off automatically after the set lighting time has elapsed.

Or: Automatically if a vehicle door or the trunk lid is still open approximately 30 seconds after switching on.

Or: Press the  button repeatedly until the **OFF** setting is displayed in the instrument cluster.

Or: Switch on the ignition.

Adjusting entry and exit lighting

The lighting time can be adjusted in the vehicle settings in the Infotainment system and the function can be activated or deactivated ⇒ [Vehicle settings menu](#).

Depending on the vehicle equipment, you can adjust the behavior of the exterior lighting in the vehicle settings in the Infotainment system.

You can choose between two display strategies in the Exterior lighting settings menu:

- Classic entry and exit lighting.

The periphery lighting, headlights and taillights are switched on and off at the same time.

- Dynamic entry and exit lighting.

The ambient lighting, headlights and taillights are switched on and off dynamically and, if necessary, in an animated pattern.

In vehicles with Keyless Access with push-button start, switching on the entry lighting when approaching can be activated or deactivated.

Light functions

Cornering lights

If the low beam headlights are switched on, a cornering light will also switch on during slow turns or in very tight corners.

 When reverse gear is engaged, the cornering lights on both sides of the vehicle will turn on automatically to better illuminate the surroundings while maneuvering.

Automatic headlight control

If automatic headlights **AUTO** are switched on, the vehicle lighting switches on and off automatically along with the instrument illumination under the following conditions:

- The light sensor has detected darkness.
- The windshield wipers are switched on for a long time.

When the lights are turned on, the yellow indicator light **AUTO** turns on ⇒ *Switching the lights on and off*.

Automatic headlight control is merely an aid and cannot always accurately detect all driving situations.

If the vehicle is equipped accordingly, the activation time of the automatic headlights can be adjusted in the vehicle settings in the Infotainment system ⇒ *Vehicle settings menu*.

Headlight range control

The headlight range must always be adapted to the vehicle load level. This provides the driver with the best possible visibility and oncoming traffic is not dazzled. To find out whether your vehicle features headlight range control, contact an authorized Volkswagen dealer or authorized Volkswagen Service Facility. Volkswagen recommends contacting an authorized Volkswagen dealer or authorized Volkswagen Service Facility.

Without headlight range control

The beam of the low beam headlights must be adjusted by an authorized Volkswagen dealer or authorized Volkswagen Service Facility to take into account the vehicle's load ⇒ . Volkswagen recommends contacting an authorized Volkswagen dealer or authorized Volkswagen Service Facility.

Dynamic headlight range control

The headlight range automatically adjusts to the vehicle load when the headlights are switched on ⇒ .

WARNING

Heavy objects in the vehicle can cause the vehicle height to change such that the headlights dazzle and distract other road users. This can cause accidents and serious or fatal injuries.

- Always adjust the light cone to the vehicle load so that other road users are not dazzled.

WARNING

If the headlight range control fails or malfunctions, the headlights may blind and distract other road users. This can cause accidents and serious or fatal injuries.

- Have the headlight range control inspected immediately by an authorized Volkswagen dealer or authorized Volkswagen Service Facility. Volkswagen recommends contacting an authorized Volkswagen dealer or authorized Volkswagen Service Facility.

Warning tones when lights are not turned off

If the ignition has been switched off and the driver door is opened, warning tones will sound under the following conditions:

- With the side lights switched on .

If the orientation lighting is switched on, the warning tone to indicate that the light is still turned on will not sound when leaving the vehicle ⇒ *Entry and exit lighting (orientation lighting)*.

Interior lighting

Instrument and switch illumination

You can adjust the instrument and switch lighting brightness in the vehicle settings in the Infotainment system ⇒ *Vehicle*

settings menu.

Depending on the vehicle equipment, the brightness of the head-up display can be adjusted ⇒ *Head-up display.*

The selected brightness will automatically adjust to the changing brightness in the vehicle.

If the automatic headlights **AUTO** are switched on, a sensor switches the low beam headlights and the instrument and switch lighting on and off automatically based on outside brightness.

Interior/reading lights, ambient lighting



Fig. 81 On the overhead console: touch-sensitive reading lights.

Switching on or off interior and reading lights

Tap the corresponding symbol:

☞ Switch the interior lights on or off.  OFF Function switched off: the interior lights will switch on automatically when unlocking or leaving the vehicle.

Touch-sensitive reading lights with manual dimming function

On the roof console and above the rear door, there can be touch-sensitive reading lights depending on the equipment *fig. 8*. By tapping the illuminated area, the respective reading light can be switched on or off.

To activate the manual dimming function, touch the illuminated area until the desired brightness level is reached.

Glove compartment and luggage compartment lights

The glove compartment and the luggage compartment may be illuminated depending on the vehicle equipment.

The relevant light turns on or off when opening and closing the glove compartment or trunk lid.

Ambient lighting

Ambient lighting can provide indirect lighting in various areas of the vehicle interior.

The brightness and, depending on the vehicle equipment, the color of the ambient lighting, can be adjusted in the Ambient light menu in the Infotainment system ⇒ *Vehicle settings menu*. If you select the setting Auto, the color of the ambient lighting changes depending on the driving mode setting.

 After the ignition has been switched off, the lights will turn off when the vehicle is locked or automatically after a few minutes. This reduces the risk of the 12 V vehicle battery being drained.

Visibility

Window wipers

Operating the windshield wiper lever

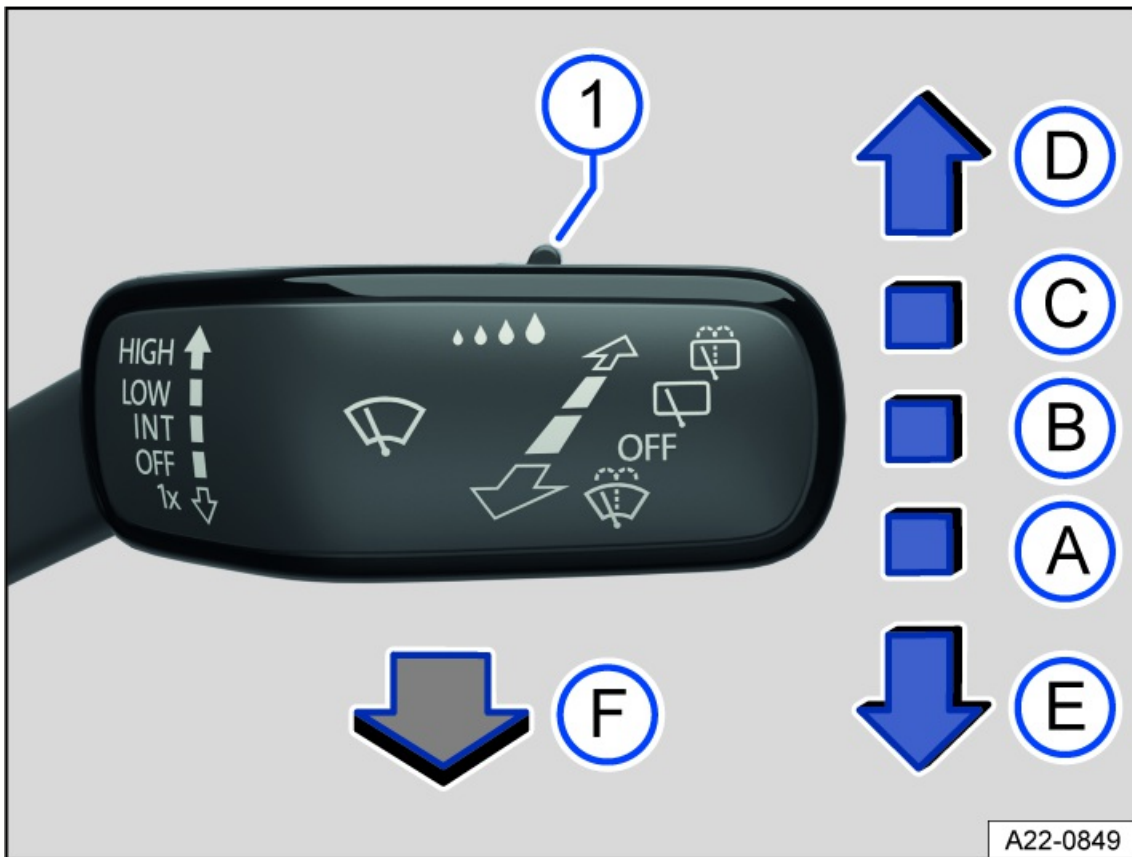











Fig. 82 On the right side of the steering column: operating the windshield wipers.

The windshield wipers only work when the ignition is switched on and the hood or trunk lid is closed. Move the wiper lever into the desired position ⇒ :

-  **OFF** Wipers are switched off.
-  **INT** Interval wiping for the windshield or rain sensor mode. Interval wiping for the windshield depends on the driving speed. The higher the speed, the faster the wipers will move.
-  **LOW** Slow wiper speed.
-  **HIGH** Fast wiping.
-  **1x** One-tap wiping – brief wiping.
-   Pull the lever to activate the automatic wiper/washer system to clean the windshield. The Climatronic switches to air recirculation for approximately 30 seconds to help prevent the windshield washer fluid odor from entering the vehicle interior.
-   Switch for interval levels (vehicles without rain/light sensor) or to adjust the sensitivity of the rain/light sensor.

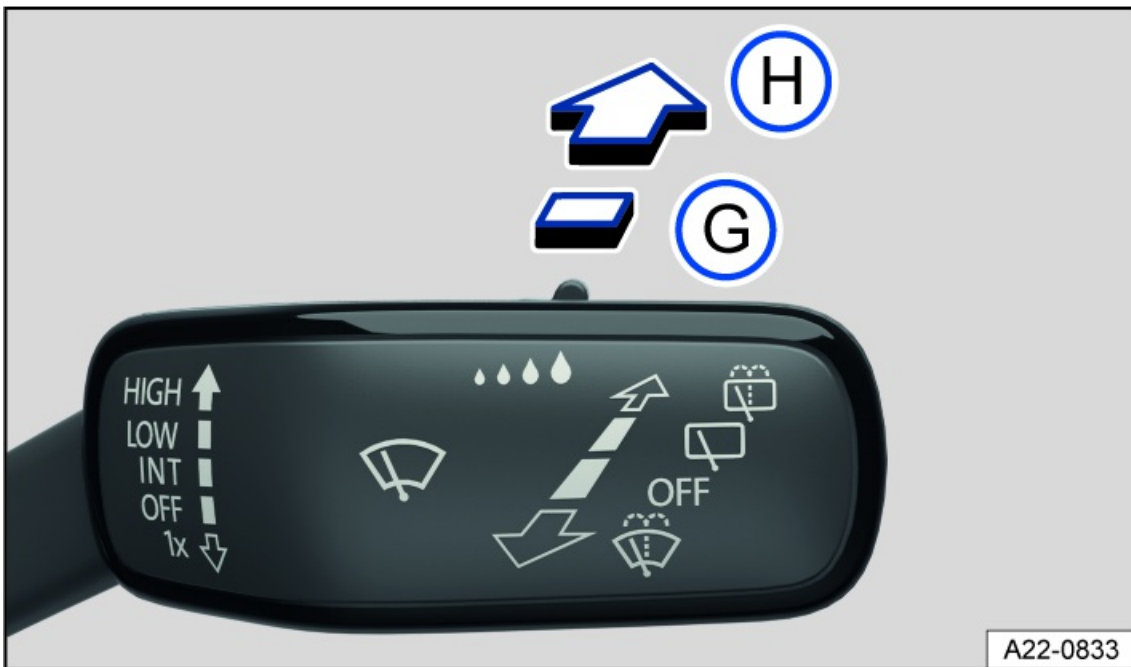







Fig. 83 On the right side of the steering column: operating the rear window wiper.

Move the wiper lever into the desired position ⇒ :

-   Interval wiping for the rear window. The wiper moves approximately every six seconds.
-   Press the lever to activate the automatic wiper/washer system to clean the rear window.

WARNING

Without the sufficient freeze protection, washer fluid can freeze on the window glass and reduce visibility. This can cause accidents and serious or fatal injuries.

- Only use the washer system with sufficient freeze protection in winter temperatures.
- Never use the window washer system in winter temperatures if the windshield has not been warmed up with the air conditioning system.

WARNING

Worn or dirty wiper blades reduce visibility and increase the risk of accidents and serious injuries.

- Always replace wiper blades if they are damaged or worn and are no longer cleaning the window glass sufficiently ⇒ *Cleaning and changing wiper blades*.

NOTICE

Incorrect handling of the windshield wipers can cause damage to the windshield, the wiper blades and the wiper motor.

- Before driving and before the ignition is switched on, check that the windshield wiper lever is in the basic position.
- Remove any snow and ice from the windshield wipers and the windshield.
- Always carefully loosen wiper blades that have frozen onto the windshield from the windshield.
- Do not turn on the windshield wipers when the windshield is dry.

 The activated wiper speed temporarily changes to the next lower speed when the vehicle is stationary.

 When parking the vehicle in cold weather conditions, moving the windshield wipers to the service position may be helpful for loosening the wiper blades more easily from the windshield ⇒ [Putting the windshield wipers in the service position](#).

Wiper function

Wiper/washer system for cleaning the windshield or rear window

The wiper/washer system cleans the windshield or rear window with the windshield wipers and windshield washer fluid. To guarantee correct functioning in all weather conditions, sufficient freeze protection must be added to the windshield washer fluid ⇒ [Washer fluid](#).

NOTICE

Without sufficient freeze protection, windshield washer fluid can freeze in the hoses filled with water and in the windshield washer tank at low temperatures. This can cause damage to the windshield washer pump.

- Always use windshield washer fluid with sufficient freeze protection.

Automatic rear window wiping

The rear window wiper switches on automatically when the windshield wipers are switched on and reverse gear is engaged. The automatic activation in reverse gear function can be activated and deactivated in the vehicle settings in the Infotainment system ⇒ [Vehicle settings menu](#).

Heated washer nozzles

The heat thaws frozen washer fluid nozzles. The heat output is automatically regulated when the ignition is switched on and is dependent on the outside temperature. Only the window washer nozzles are heated and not the washer fluid hoses.

Cleaning system of the Rear View Camera system

The cleaning system of the Rear View Camera system cleans the Rear View Camera system and works with the automatic wiper washing system to clean the rear window.

If, after washing the camera several times, the camera's view is still limited, clean the camera lens manually ⇒ [Rear view](#), ⇒ [Exterior care and cleaning](#).

Rain/light sensor

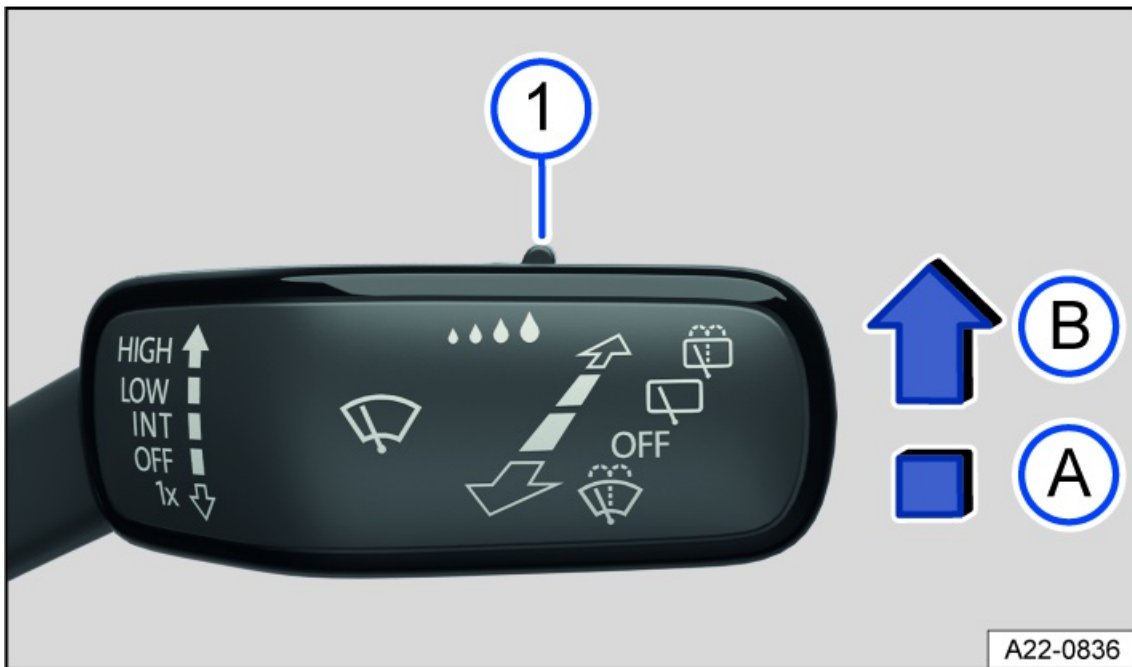

Fig. 84 On the right side of the steering column: windshield wiper lever.

- ① Switch for adjusting the sensitivity of the rain/light sensor.
- Ⓐ Rain/light sensor deactivated.
- Ⓑ Rain/light sensor activated, automatic wiping as necessary.

When switched on, the rain/light sensor automatically shortens or lengthens the delay between wiping cycles depending on how hard it is raining.

Activating and deactivating the rain/light sensor

1. Press the lever into the desired position *fig. 84*.

Automatic wiping can be activated and deactivated in the vehicle settings in the Infotainment system ⇒ *Vehicle settings menu*

If automatic wiping is deactivated in the Infotainment system, the interval time will be set in fixed stages.

Adjusting the sensitivity of the rain/light sensor

The sensitivity of the rain/light sensor can be manually adjusted with the switch in the windshield wiper lever *fig. 84*, ⇒ ⚠.

- Move the switch to the right – high sensitivity.
- Move the switch to the left – low sensitivity.

⚠ WARNING

The rain/light sensor cannot detect all precipitation sufficiently and activate the windshield wipers accordingly. Reduced visibility can cause accidents and serious or fatal injuries.

- If necessary, switch on the windshield wipers manually if water on the windshield is impairing visibility.

Troubleshooting

🚰 Washer fluid level too low

The yellow indicator light turns on.

1. Fill the washer fluid reservoir ⇒ *Washer fluid*.

Windshield wiper malfunction

The yellow indicator light turns on.

The windshield wipers are not working.

1. Contact a suitably qualified professional. Volkswagen recommends contacting an authorized Volkswagen dealer or authorized Volkswagen Service Facility.

Rain/light sensor malfunction

The yellow indicator light turns on.

The windshield wipers will not be automatically activated in rain/light sensor mode when it is raining.

1. Contact a suitably qualified professional. Volkswagen recommends contacting an authorized Volkswagen dealer or authorized Volkswagen Service Facility.

Changes to rain/light sensor reaction

Some possible reasons for malfunctions and misinterpretations in the sensor area of the rain/light sensor ⇒ [View from the front](#) could be:

- **Damaged wiper blades:** damaged wiper blades can leave a film of water or streaks on the window, and this can extend the activation time, greatly shorten the wiper intervals, or cause fast wiping time.
- **Insects:** insects hitting the windshield may trigger the wipers.
- **Salt streaks:** salt streaks on the windshield from driving in the winter can cause the wipers to wipe more frequently or continuously on a window that is almost dry.
- **Dirt:** dried dust, wax, any other build-up on the windshield (lotus effect), or washing product residue (car wash) can lower the sensitivity of the rain/light sensor and cause it to react too slowly or not at all. Clean the sensor area for the rain/light sensor regularly and check the wiper blades for damage ⇒ [Exterior care and cleaning](#).
- **Crack in the windshield:** if a stone strikes and chips the sensor area while the rain/light sensor is on, this will trigger a wiper cycle. After that, the rain/light sensor will detect this irregularity on the sensor surface and react to it. Depending on the size of the chip, the reaction behavior of the rain/light sensor may or may not change.

 If there is an obstacle for the wipers on the window glass, the wipers will attempt to remove it. If it continues to block the wipers, the wipers will stop moving.

1. Remove the obstacle and switch the wipers on again.

Mirrors

General safety precautions

Using the outside mirrors and the interior rearview mirror, the driver can observe traffic and adjust their driving based on traffic.

For driving safety, it is important that the driver adjusts the outside mirrors and the interior rearview mirror correctly before starting to drive.

It is not possible to oversee the entire side and rear area of the vehicle by looking in the outside and interior rearview mirrors. These areas that are not visible are called blind spots. Other road users and objects could be in the blind spot.

WARNING

Adjusting the outside mirrors and interior rearview mirror while driving can distract the driver. This can cause accidents and serious or fatal injuries.

- Only adjust the outside mirror and interior rearview mirror when the vehicle is stationary.

- Always make sure that the mirrors are adjusted correctly and visibility to the rear is not limited by ice, snow, fog, or other objects.

WARNING

The view in the outside mirrors and interior rearview mirror does not cover the entire area around the side and rear of the vehicle. Other road users and objects could be in these blind spots. This can cause accidents and serious or fatal injuries.

- When parking, changing lanes, passing, and turning, always pay attention to your surroundings.

WARNING

Curved mirror surfaces (depending on the country: convex or aspheric) enlarge the field of vision and allow objects in the mirror to appear smaller and farther away. This can make it difficult to estimate the exact distance from the vehicles behind, e.g. when changing lane. This can cause accidents and serious or fatal injuries.

- Use the interior rearview mirror as much as possible to more accurately determine the distance to vehicles or other objects behind you.
- Make sure there is sufficient visibility of the area behind the vehicle.

WARNING

An automatic dimming rearview mirror contains an electrolyte fluid that can leak out if the mirror glass breaks. Coming into contact with this liquid can irritate the skin, eyes, and respiratory organs, especially in individuals with asthma or similar illnesses. This may cause serious injuries.

- If electrolyte fluid is swallowed, rinse out the mouth immediately for at least 15 minutes with plenty of water. Do not induce vomiting unless it ordered to do so by a doctor. Call for medical assistance immediately.
- Immediately get plenty of fresh air and exit the vehicle. If this is not possible, open all the windows and doors.
- If the electrolyte fluid comes into contact with eyes or skin, wash the affected area immediately for at least 15 minutes with plenty of water and seek medical assistance.
- If the electrolyte fluid comes into contact with your shoes or clothing, wash it for at least 15 minutes with plenty of water. Clean the shoes and clothing thoroughly before wearing them again.

NOTICE

If the glass on an automatic dimming mirror breaks, electrolyte fluid can leak out. This fluid damages plastic surfaces.

- Remove any leaking fluid as soon as possible, for instance using a wet sponge.

Interior rearview mirror

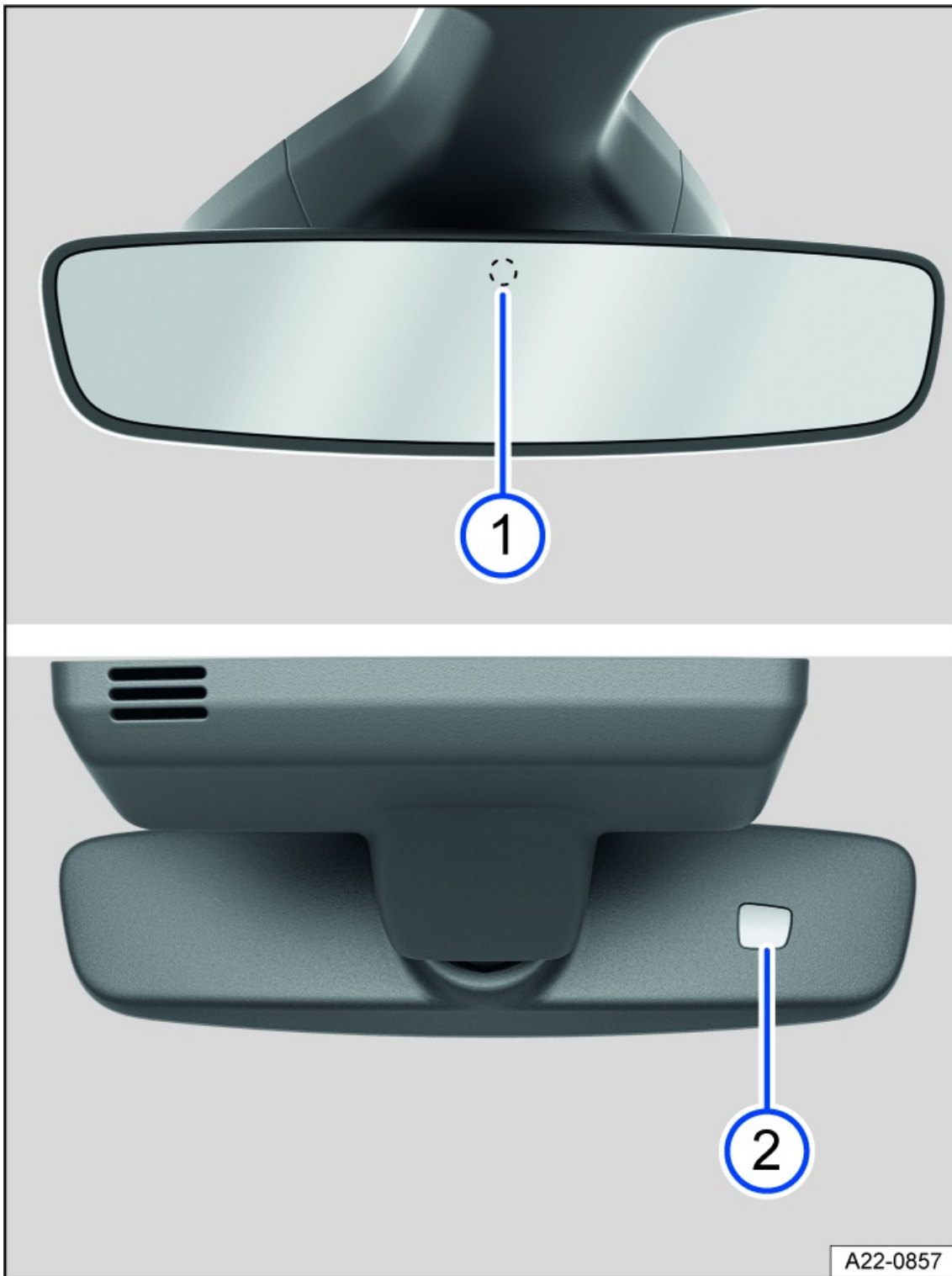

Fig. 85 On the windshield: automatic dimming interior rearview mirror.

- ① Sensor for light entering from the rear.
- ② Sensor for light entering from the front.

Automatic dimming interior rearview mirror

When the ignition is on, the sensors measure the amount of light entering from the rear [fig. 85 ①](#) and from the front [②](#).

Depending on the measured values, the interior rearview mirror will dim *automatically*.

If the amount of light entering the sensors is limited or interrupted, for example by a sunshade or attachment, the automatic dimming interior rearview mirror may not function or may malfunction. Mobile navigation devices on the windshield or near the automatic dimming interior rearview mirror can also affect the sensors ⇒ ⚠.

Automatic dimming will be deactivated in some situations, for example when the interior lighting in the roof console is switched

on or when reverse gear is engaged.

⚠ WARNING

The illuminated display of a mobile navigation system may interfere with the automatic dimming interior rearview mirror. This may stop you from using the interior rearview mirror to accurately determine the distance from vehicles or other objects behind you. Accidents and serious or fatal injuries could result.

- Switch the mobile navigation system off in such cases.

Outside mirrors

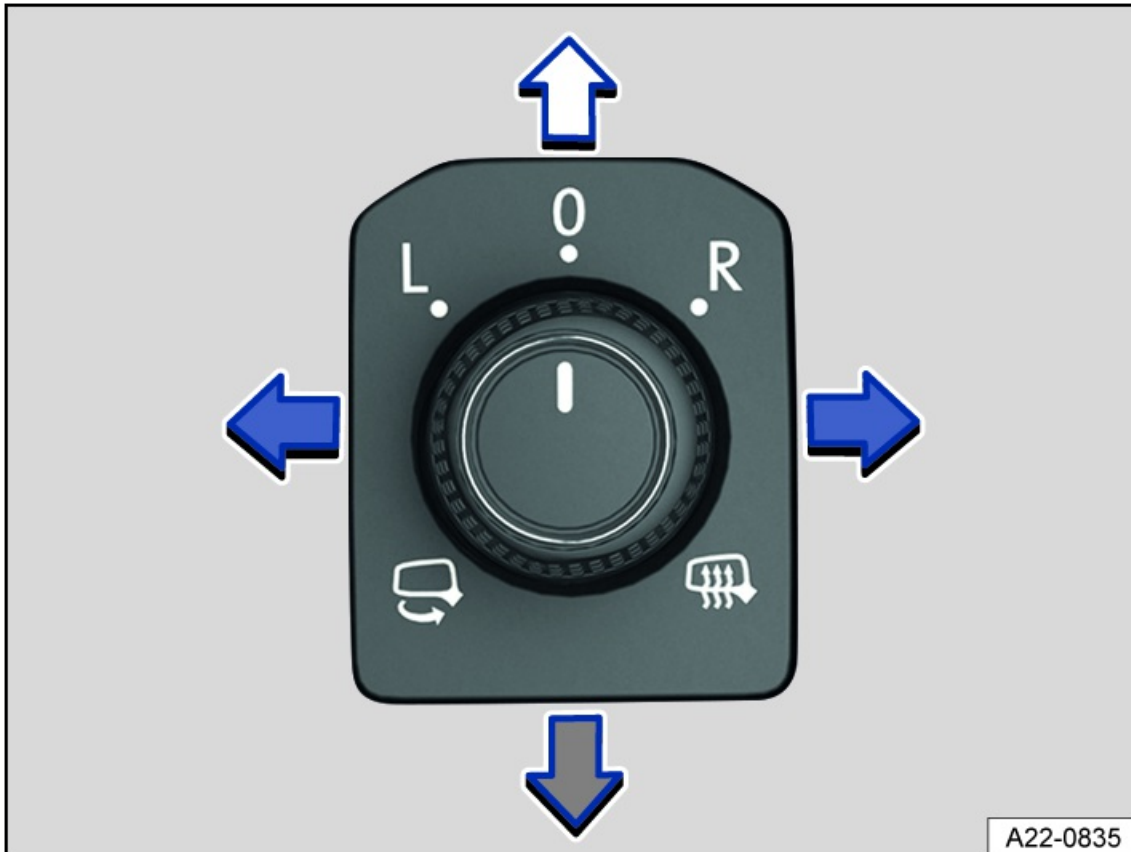

Fig. 86 In the driver door: knob for the outside mirrors.

The following information describes the outside mirror functions for left-hand drive vehicles. Position **L** corresponds to the outside mirror on the driver's side, and position **R** corresponds to the outside mirror on the passenger's side. For right-hand drive vehicles, proceed in the reverse order.

Adjusting outside mirrors

1. Switch the ignition on.
2. Turn the knob in the driver door to the preferred symbol [fig. 86](#).
3. To adjust the outside mirror, push the knob forward, back, right or left in the direction of the arrow.



Fold the outside mirror in towards the vehicle body ⇒ ⚠.



Switch on the outside mirror heating. The exterior mirror heating only works when the ambient temperature is below approx. 20 °C (around 68 °F) and provides the most heat when it first turns on. After about two minutes, the mirrors will be heated depending on the ambient temperature.

L

Adjusts the left outside mirror.

R

Adjusts the right outside mirror.

0 Neutral position. The outside mirror cannot be adjusted and all functions are switched off.

Activating outside mirror functions

The following outside mirror functions must be activated in the vehicle settings in the Infotainment system before they are used for the first time ⇒ [Vehicle settings menu](#).

Synchronized mirror adjustment

Depending on vehicle equipment, it may be possible to adjust both outside mirrors at the same time.

1. Turn rotary knob to position **L**.
2. Adjusts the left outside mirror. The right outside mirror will be adjusted the same way (synchronized).
3. To correct the adjustment of the right outside mirror, if necessary, turn the knob to the **R** position and adjust the right outside mirror.

Folding the outside mirrors in while parking

If the vehicle is locked or unlocked from the outside, the outside mirrors will automatically fold in or out. For this to happen, the knob must be in the , **L**, **R** or **0** position.

If the knob for power exterior mirrors is in the  position, the outside mirrors will remain folded in.

Save the passenger-side outside mirror settings when reversing

1. Unlock the vehicle using the key, to which the setting is allocated.
2. Set the electronic parking brake.
3. Switch the ignition on.
4. Shift the transmission to neutral.
5. Select the reverse gear.
6. Adjust the front passenger outside mirror so that, for example, the edge of the curb can be seen clearly.
7. Shift the transmission to neutral.
8. Switch the ignition off.

The selected mirror position will be stored and assigned to the vehicle key.

Opening the front passenger outside mirror settings for driving in reverse

1. Turn rotary knob for the outside mirrors to the relevant position for adjusting the front passenger outside mirror.
2. With the ignition switched on, select reverse gear.

The front passenger outside mirror will adjust to the stored position.

The front passenger outside mirror will exit the position stored for driving in reverse when you begin driving forward faster than about 15 km/h (about 9 mph) or when the knob is turned to any other position.

WARNING

If you fold the outside mirrors against the vehicle or back without taking care, you could get your fingers jammed between the outside mirror and the mirror base. This can cause severe injuries.

- Do not fold the outside mirrors out or in if there are any obstacles in the path.

NOTICE

If outside mirrors are not folded in when driving through a car wash, they can get damaged.

- Always fold in the outside mirrors.

! NOTICE

Folding in the power exterior mirror manually can worsen wear and tear or damage the mirror motor.

- Do not fold power exterior mirrors in or out by hand.

🍃 Leave the outside mirror heating on only as long as it is needed. Otherwise fuel will be used unnecessarily.

i If there is a malfunction in the power outside mirror, you can adjust the position of the mirror manually by hand by pushing on the edge of the mirror surface.

Sunshade

Sun visors

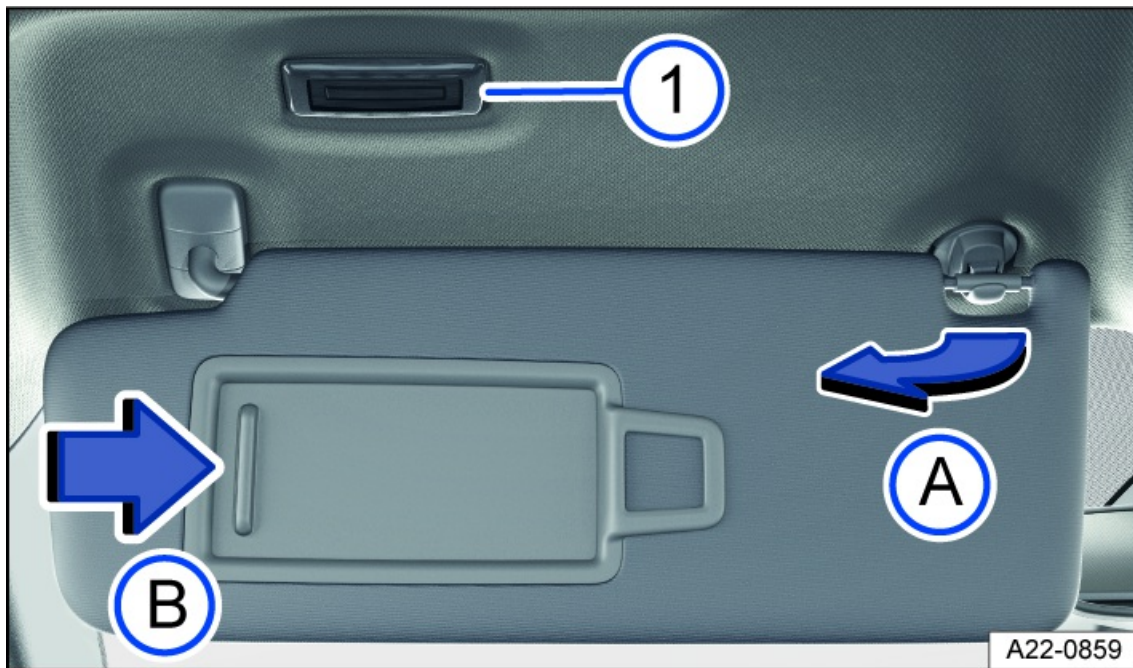

Fig. 87 In the front of the headliner: sun visor.

- ① Light.
- Ⓐ Remove from holder.
- Ⓑ Slide cover open.

Adjustment options for the sun visors

- Fold toward the windshield.
- Remove from the holder and tilt toward the door *fig. 87*.

Adjustment options for the sun visor

In some vehicle models, the sun visor can be moved farther toward the rear when it is tilted toward the door.

Illuminated vanity mirror

When the sun visor is folded down, there is a vanity mirror located behind a cover. The lights [fig. 87](#) turn on when the cover [fig. 87](#) slides open.

The lighting for the vanity mirror switches off in the following situations:

- The cover is closed.
- The sun visor is swung upwards or fully forwards.
- The sun visor is pushed in a longitudinal direction or not fully pushed in.

WARNING

Visibility may be reduced when sun visors are folded down and the sunshades are extended. This can cause accidents and serious or fatal injuries.

- Always guide sun visors and sunshades back into their holders when they are no longer needed.

 Under certain conditions, the light above the sun visor will turn off automatically after several minutes. This reduces the risk of the 12 V vehicle battery being drained.

Sunshade in the sunroof



Fig. 88 In the headliner: Function keys for controlling the sunshade.

The power sunshade only works when the ignition is switched on.

When the sunroof is tilted all the way open, the sunshade automatically moves into a position that provides ventilation. The sunshade will remain in the ventilation position after the tilting and sliding panoramic sunroof is closed.

Opening the sunshade

- Automatic process: Swipe backward on the function key [fig. 88](#). The automatic process is interrupted if you tap or swipe over the function key again.

- Manual process: Swipe backward on the function key and hold until it reaches the desired position.

Closing the sunshade

- Automatic process: Swipe forward on the function key *fig. 88*. The automatic process is interrupted if you tap or swipe over the function key again.
- Manual process: Swipe forward on the function key and hold until it reaches the desired position.

Sunshade pinch protection

The pinch protection can reduce the risk of being pinched and injured when the sunshade is closing ⇒ . If the sunshade encounters resistance or an obstacle when closing, the sunroof will open again immediately.

1. Check why the sunroof did not close.
2. Try again to close the sunshade.

If the sunshade still encounters resistance or an obstacle and will not close, open the sunshade again. Within a short time after opening, you can close the sunshade again without pinch protection.

3. If the sunshade is still not able to close, close the sunshade without pinch protection.

Closing the sunshade without pinch protection

1. Try again to close the sunshade.
2. If the sunshade still cannot be closed, swipe forward on the function key within 5 seconds *fig. 88* and hold until the sunshade is completely closed.

This will close the sunshade without pinch protection.

3. If the sunshade still will not close, contact an authorized Volkswagen dealer or authorized Volkswagen Service Facility for assistance. Volkswagen recommends contacting an authorized Volkswagen dealer or authorized Volkswagen Service Facility.

If you release the function key during the closing process, the sunshade will open again automatically.

Control is responding differently than expected

Moisture, dirt and grease may limit the functioning of the control.

1. Always keep the control clean and dry.

WARNING

Closing the sunshade without pinch protection may result in serious injuries.

- Always be careful when closing the sunshade.
- Ensure that nobody is within the range of operation of the sunshade, especially if it is closing without pinch protection.

Sunshade for the rear side windows

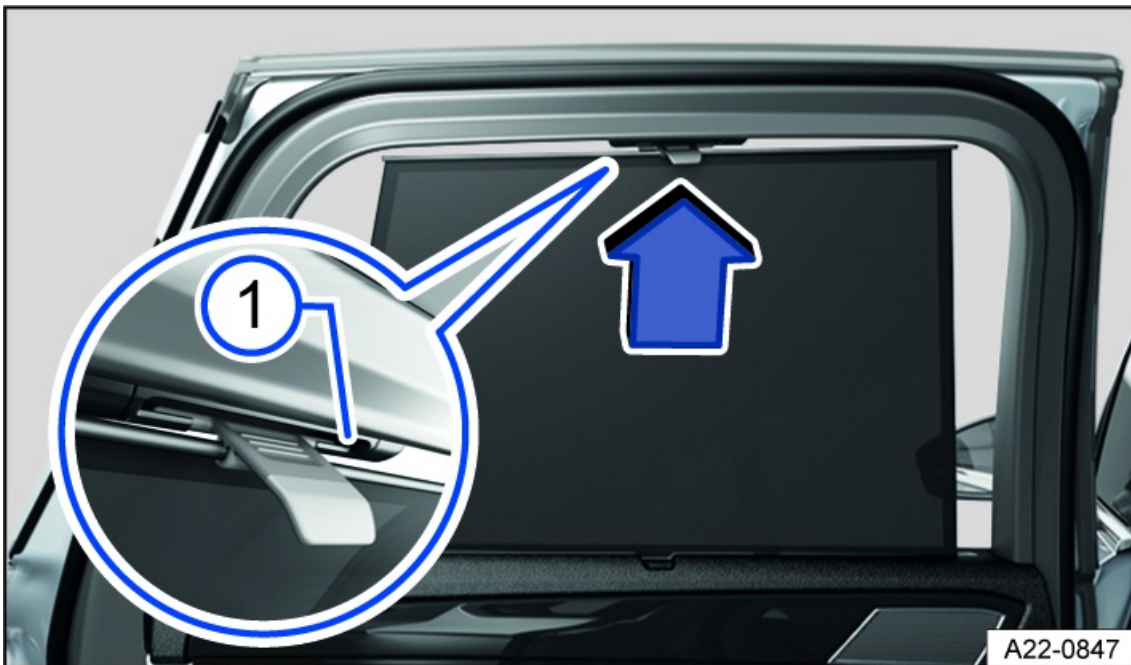

Fig. 89 In the right window: sunshade (general example).

The sunshades for the rear side windows are installed in the door trim panels on the windows.

1. Pull the sunshade all the way upward by the handle in the direction of the arrow *fig. 89*.
2. Secure the rod with both eyelets in its holder *fig. 89*.
3. Check that the extended sunshade is securely hooked in the holder.

To roll down, release the sunshade at the top and guide it downward by hand ⇒ ⚠.

⚠ NOTICE

An uncontrolled reeling of the sunshade can result in damage to the sunshade or interior trim.

- Always guide the sunshade down by hand and do not allow it to “snap” down unaided.

Heating and air conditioning system

Climatronic

Overview of the Climatronic

Climatronic is an automatic air conditioning system which warms, cools and dehumidifies the air. In automatic mode, Climatronic can automatically control the air temperature, air distribution and the volume of air.

Some functions of the air conditioner, as well as a climate control bar for the rear seats, depend on the vehicle equipment.

Making Efficient Use of the Air Conditioner

The air conditioner is most effective when the vehicle interior is kept closed. In the event of heat build-up in the vehicle interior, brief ventilation can accelerate the cooling process.

Display of activated functions

Illuminated symbols on the sensor areas indicate functions that are switched on.

Function keys highlighted in color in the Air conditioner menu in the Infotainment system indicate functions that are switched on ⇒ [Air conditioner menu in the Infotainment system](#).

Air conditioner with voice command operation

Some of the air conditioner functions can be operated with voice control, depending on the vehicle equipment ⇒ [Voice control](#).

WARNING

Icy, snow-covered or foggy door windows restrict visibility very severely. This increases the risk of collisions and accidents, which may result in serious or fatal injuries.

- Keep all windows free of ice, snow and fog.
- Adjust the heating, air conditioner, and rear window defroster to a setting where the windows do not fog up ⇒ [Troubleshooting](#).
- Only start driving when all windows are clear.
- Only use recirculation mode for a short time. Otherwise, the windows could fog up very quickly and greatly reduce visibility.
- Always switch off recirculation mode as soon as it is not necessary.

Air conditioner menu in the Infotainment system

In the upper center console

 Open the Air conditioner menu in the Infotainment system.

In the Classic Climate and Smart Climate submenus, you can find, for example, the functions for temperature regulation ⇒ [Temperature regulation](#) and air distribution ⇒ [Air distribution and blower speed](#).

Depending on the vehicle equipment, the Classic Climate menu may also be called Climate control.

The Smart Climate submenu is available depending on the vehicle equipment.

Climate control settings submenu

 Depending on the vehicle equipment, you can find additional comfort functions in the Climate control settings submenu:



- Switch on automatic air recirculation ⇒ *Air recirculation*.
- Switch on seat heating and seat ventilation automatically at the beginning of the journey ⇒ *Using Seat Heating and Seat Ventilation*.
- Switch on steering wheel heating automatically at the beginning of the journey ⇒ *Steering wheel heating*.

Switching the Climatronic on and off

In the Air conditioner menu: top of the screen



Switch the air conditioning system on and off.

1. Tap  in the upper center console.
2. Tap  in the Air conditioner menu.

Automatic mode of the Climatronic

In the air conditioner menu

AUTO The set air temperature is maintained constant. The air volume and air distribution are automatically controlled. Automatic mode switches off when the blower speed is changed manually.

If a Smart Climate function is switched on, the Climatronic automatic mode will also be switched on ⇒ *Air distribution and blower speed*.

Selecting an Air Conditioner Profile

You can set the blower speed in automatic mode via the air conditioner profiles.

1. Open the Air conditioner menu in the Infotainment system.
2. To switch on the Climatronic's automatic mode, tap **AUTO**.
3. Select your preferred air conditioner profile in the pop-up window that appears.

Air Care

In the Air conditioner menu: Air Care submenu

The Air Care Climatronic active combination filter can limit the entrance of hazardous substances as well as allergens.

If Air Care is switched on, the air recirculation of the air conditioner is maximized as far as permitted by the risk of fogging up the windows depending on the humidity in the vehicle interior and the outside temperature. Air recirculation is controlled automatically and adapts itself continuously to prevent vehicle occupant fatigue.

Switching Air Care on and off

1. Open the Air conditioner menu in the Infotainment system.
2. Tap Air Care.
3. Tap Active.

Temperature regulation

in the Infotainment system: Bottom of the screen

 Adjust the temperature. The temperature settings are displayed permanently at the bottom of the screen in the Infotainment system.

The set temperature for the rear seats is displayed in the climate control bar for the rear seats.

In the Air conditioner menu: Classic Climate submenu



A/C The air is cooled and dehumidified in cooling mode. **SYNC** Apply temperature settings for the driver side to all seats.

MAX A/C Switch the maximum cooling output on and off.

Air recirculation is switched on automatically and Climatronic automatically directs air to the upper body.

On the Infotainment system: setting the temperature with the touch control

Depending on the equipment, you can set the temperature via the touch control on the Infotainment system.



1. To set the temperature of the Climatronic to +22 °C (+72 °F), tap and hold the touch control in the center between  and .

Or: to set a different temperature, swipe to the right or left on the touch control.

The set temperatures are displayed at the bottom of the screen in the Infotainment system.

Adjusting the temperature for the rear seats

REAR Open the settings for the rear seats in the Infotainment system.

1. Open the Air conditioner menu in the Infotainment system.
2. Tap .
3. Tap the  or  function key.

Or: tap  or  in the climate control bar for the rear seats.

The set temperatures for the rear seats are shown on the climate control bar displays for the rear seats.

 If REAR LOCK is switched on in the Infotainment system, the rear climate control bar cannot be used.

Air distribution and blower speed

Vents

Vents are located in the following places in the vehicle:







- Driver's side.
- Passenger's side.
- Front center console.
- Rear center console.

NOTICE

Food, medication, and objects that are sensitive to heat or cold can become damaged or unusable from the air coming out of the vents.







- Do not place any food, medication, or other objects that are sensitive to temperature in front of the vents.

Air distribution functions in the Air conditioner menu: Classic Climate

 Set the blower speed with the touch control.  Direct air to the upper body.  Direct air into the footwell.  Direct air to the upper body and into the footwell.  Direct air onto the windshield and into the footwell.  Direct air onto the windshield.

Air distribution functions in the Air conditioner menu: Smart Climate

If a Smart Climate function is switched on, Climatronic automatic mode is also switched on. The Smart Climate functions remain switched on for a short time and automatic mode also remains switched on once this time has elapsed.

 Clear fog and ice from the windshield.  Direct warm air into the footwell.  Direct warm air onto the steering wheel.  Direct cool air into the footwell.  Direct fresh air from outside into the vehicle interior.  Temporarily increase the power of the refrigerant system.

Defrost function

On the control next to multi-function steering wheel

 The Climatronic defrost function clears fog and ice from the windshield.
The air is dehumidified and the blower is set to a higher speed.

Air recirculation



No fresh air will enter the vehicle interior when recirculation mode is switched on ⇒ .

 Switch air recirculation on and off in the Air conditioner menu.

1. Open the Air conditioner menu in the Infotainment system.
2. Tap Classic Climate.
3. Tap .

Automatic recirculation mode on the Climatronic system

Automatic air recirculation helps you if the outside air is of poor quality by temporarily turning on or off the supply of fresh air, within the system limitations. The system cannot detect unpleasant odors.

1. Tap  in the upper center console.
2. Switch automatic air recirculation on or off with  ► Automatic air recirculation.

When does recirculation mode switch off?

Recirculation mode will switch off in the following situations:

- If the defrost function is switched on.
- If a sensor detects that the door windows could fog up.

WARNING

A lack of fresh air supply may result in reduced visibility due to fogged up windows and rapid driver fatigue due to stale air. This can result in collisions, accidents and serious or fatal injuries.

- Only use recirculation mode for a short time.
- Always switch off recirculation mode as soon as it is not necessary.

NOTICE

Tobacco smoke can settle on the refrigerant system evaporator and the active combination filter and cause permanent odors.

- To prevent permanent odors, do not smoke in the vehicle when air recirculation is switched on.



 When reverse gear is engaged or while the automatic wash and wipe system is on, recirculation mode switches on automatically so that no odors will enter the vehicle interior.

Seat heating and seat ventilation

[Overview of Seat Heating and Seat Ventilation](#)

The seat heating and seat ventilation function when the engine is running. The front seats can be equipped with either a seat heating system or a combined seat heating and seat ventilation system. There are three levels of heating for the outer rear seats ⇒ .



The seat ventilation function ventilates the seat using vehicle interior air. This removes moisture from the body. The seat itself is not cooled directly.

 Switch the seat heating on and off in the Air conditioner menu.  Switch the seat ventilation on and off in the Air conditioner menu.

Heating and ventilation levels

The operation statuses of the seat heating and seat ventilation are represented by colors in the Infotainment system.

At the highest heating level, all three indicators under  or  in the Infotainment system are red.

At the highest ventilation level, all three indicators under  or  in the Infotainment system are blue.

When should the seat heating and seat ventilation be switched off?

Switch off the seat heating and seat ventilation under any of the following conditions:

- The seat is occupied by a person with a limited perception of pain or temperature ⇒ .
- The seat is not occupied
- A child restraint is installed on the seat
- Objects are covering the seat cushion, e.g. protective covers, jackets, blankets or bags.
- The seat surface is damp or wet
- Seat heating only: The interior or exterior temperature is higher than +25 °C (+77 °F).

WARNING

Magnetic fields are generated when the seat heating is operated. In individual cases, these magnetic fields can affect active medical implants (e.g. pacemakers).

- If you have a medical implant, you should consult your doctor or the manufacturer of the implant before operating the seat heating.
- Also make your vehicle occupants aware.

WARNING

People who cannot perceive pain or temperature or who have a limited perception of these due to medication, paralysis, or chronic illnesses such as diabetes could develop burns or undercooling on the back, buttocks, and legs when using seat heating or seat ventilation. Such injuries could take a very long time to heal or may never heal completely.

- If you have a limited perception of pain and/or temperature, never use the seat heating and seat ventilation and leave the "Automatic seat air conditioning at the beginning of the journey" function switched off ⇒ *Automatic seat air conditioning at the beginning of the journey*.
- Contact a medical doctor for questions about personal health conditions.

WARNING

If the seat cover is soaked through, this can cause the seat heating to malfunction and increase the risk of burns.

- Make sure the seat surface is dry before using the seat heating function.
- Do not sit on the seat with wet clothing.
- Do not place any wet objects or clothing on the seat.



- Do not pour any fluids on the seat.

! NOTICE







The heating elements of the seat heating may be damaged by loads concentrated in a single place and insulating materials.

- Do not kneel on the seats and do not exert pressure on the seat cushion and backrest with sharp or pointed objects.
- Do not exert pressure on the seat cushion and backrest with pointed objects.
- Switch the seat heating off if insulating materials are installed on the seat, e.g. a protective cover or a child restraint.
- Only use the seat heating if the seat is equipped with the original seat covers.
- If any odor starts to develop, turn off the seat heating immediately and have it checked by suitably qualified professionals. Volkswagen recommends contacting an authorized Volkswagen dealer or authorized Volkswagen Service Facility.

Using Seat Heating and Seat Ventilation







 Please read the introductory information and heed the Warnings and Notice  and  [Overview of Seat Heating and Seat Ventilation](#).

Using the seat heating function

1. Open the Air conditioner menu in the Infotainment system \Rightarrow [Air conditioner menu in the Infotainment system](#).
2. To switch on the seat heating at the highest heating level, tap  or  at the bottom edge of the screen.
3. To set the heating level, tap  or  repeatedly.
4. To switch the seat heating off, tap  or  repeatedly until the symbol is gray.

Or: to switch the seat heating on or off, tap with two fingers on the touch control under the Infotainment system on the driver's or passenger's side (depending on the vehicle equipment).

Using the seat ventilation function

1. Open the Air conditioner menu in the Infotainment system \Rightarrow [Air conditioner menu in the Infotainment system](#).
2. To switch on the seat ventilation at the highest ventilation level, tap  or  at the bottom edge of the screen.
3. To set the ventilation level, tap  or  repeatedly.
4. To switch the seat ventilation off, tap  or  repeatedly until the symbol is grey.

 In order to save fuel, switch off the seat heating and seat ventilation as soon as possible.



The seat heating switches on and off automatically



If you start the engine again within approximately ten minutes, the last heating level set for the driver seat is automatically switched on. If the front passenger seat is occupied, the last heating level set for the front passenger seat is also switched on automatically.

If the front passenger leaves their seat when the seat heating is switched on and the engine is running, the seat heating for the front passenger seat is automatically switched off. The display in the Infotainment system turns grey after approximately two seconds. If the front passenger takes their seat again when the engine is still running, the seat heating for the front passenger

seat is automatically switched back on.

Automatic seat air conditioning at the beginning of the journey

 Please read the introductory information and heed the Warnings and Notice  and  [Overview of Seat Heating and Seat Ventilation](#).

1. Open the Air conditioner menu in the Infotainment system.
2. To open the Climate control settings submenu, tap .
3. To select the heating and ventilation level at the beginning of the journey, tap  in the Seat heating or Seat ventilation menu item.

The selected heating and ventilation level is automatically switched on after starting the engine, depending on the outside temperature.

Or: To stop seat heating and seat ventilation being switched on automatically at the beginning of the journey, select Off in the respective menu item.

Steering wheel heating



The steering wheel heating only works when the engine is running.

 Switch steering wheel heating on and off via the multi-function steering wheel.

Heating levels for the steering wheel heating

The steering wheel heating modes are shown by colors in the Infotainment system. At the highest heating level, all three indicators under  in the Infotainment system are red.

Operating steering wheel heating

1. To switch on steering wheel heating at the highest heating level, press the  button.
2. To adjust the heating level, press the  button repeatedly.
3. To switch off steering wheel heating, press the  button repeatedly until the bar display in the instrument cluster displays turns off.

Steering wheel heating switches on automatically

If you start the engine again within approximately ten minutes, the last heating level set is automatically switched on.

Saving the heating level

1. Switch on the steering wheel heating and set the desired heating level.
2. To save the current heating level, press and hold the  button for approximately one second.

The heating level is saved and the steering wheel heating is switched off.

3. To switch the steering wheel heating back on at the most recently saved heating level, press and hold the  button for approximately one second.

Switching on steering wheel heating automatically at the beginning of the journey

1. Open the Air conditioner menu in the Infotainment system.
2. To open the Climate control settings submenu, tap .
3. Activate the Steering wheel heating checkbox.

The steering wheel heating is automatically switched on after starting the engine, depending on the outside temperature.

Steering wheel heating switches off automatically

If one of the following conditions applies, the steering wheel heating switches off automatically:

- If the energy use is too high.
- If the steering wheel heating system is malfunctioning.

Rear window defroster

The rear window defroster works when the engine is running.

 Switch the rear window defroster on and off on the control panel to the left of the multi-function steering wheel.
REAR
The rear window defroster switches off automatically after a maximum of around ten minutes.

! NOTICE

Stickers that are placed on the inside of the rear window over the heat conductors of the rear window defroster, or objects that rest against the inside of the rear window may damage the rear window defroster.

- Do not affix any stickers over the heat conductors of the rear window defroster.
- Do not load the luggage compartment to a height where objects rest against the rear window.

 In order to save fuel, switch off the rear window defroster as soon as possible.

Troubleshooting

The cooling mode **A/C** or heating cannot be switched on or the function is limited

The **A/C** cooling mode only works when the engine is running and at ambient temperatures above +3 °C (+38 °F).

The heating and defrost function operates better when the engine is warm.

If the engine is very hot or if the outside temperature is extremely high, the function of the cooling mode **A/C**, the heating or the defrost may be restricted.

- Switch on the fan.
- Check the safeguard on the air conditioning system ⇒ *Replacing fuses*.
- Change active combination filters ⇒ *Service*.
- If the malfunction persists, contact a suitably qualified professional. Volkswagen recommends contacting an authorized Volkswagen dealer or authorized Volkswagen Service Facility.

! NOTICE

If the air conditioner is not working and is operated further, that can cause subsequent damage.

- If the air conditioner is not cooling or warming the air, switch it off immediately.
- Have the air conditioner checked by suitably qualified professionals. Volkswagen recommends contacting an authorized Volkswagen dealer or authorized Volkswagen Service Facility.

The windows are fogged up

The door windows fog up if they are colder than the ambient temperature and the air is damp. Cold air does not absorb as much moisture as warm air which is why windows fog up more frequently during cold seasons.

1. To improve the heating and cooling output, keep the air intake in front of the windshield free of ice, snow, and leaves
⇒ *Vehicle care*.

2. Leave the air duct in the rear section of the luggage compartment uncovered so that air can flow through the vehicle from front to back.
3. Switch on the defrost function ⇒ *Defrost function*.

The temperature unit has changed

You can change the unit for all temperature displays in the vehicle using the Infotainment system.

1. Tap the home button .
2. Open the Settings menu.
3. Select the Units menu item.

Water or water vapor under the vehicle

In the case of high outside humidity and temperatures, condensation can drip from the air conditioning system evaporator and pool under the vehicle. This is normal and does not mean there is a leak in the system.

Controls are responding differently than expected

Moisture, dirt and grease may limit the functioning of the controls.

1. Always keep the control panels clean and dry.

Driving

Steering

Steering information

To make it more difficult to steal the vehicle, the steering must always be locked before leaving the vehicle.

Steering

Power steering on an electromechanical steering system adjusts automatically based on the driving speed, the steering torque, and the steering angle of the wheels. Electromechanical power steering works only when the engine is running. The steering also works if the start-stop system engages and the engine switches off.

If the power steering system is impaired or malfunctioning, a significantly greater amount of force than normal must be used to steer.

On vehicles with Driving Mode Selection, power steering handling can be influenced by the selected driving mode.

Electronic steering lock

On vehicles with a starter button, the steering column is electronically locked, depending on the vehicle equipment and country.

1. Stop the vehicle.
2. Engage the parking lock **P**.
3. Switch the ignition off and then open the driver's door.

The steering column will be locked.

If the steering column does not lock, first open the driver's door and then switch the ignition off. As long as the vehicle is unlocked, the steering column also stays unlocked.

Countersteering assist

The counter-steering assistance provides the driver with power steering in some critical driving situations. Additional steering power, together with the ESC, supports the driver when counter-steering ⇒ .

WARNING

Depending on the equipment, power steering may only work when the engine is running. If the power steering is not functioning, the steering wheel becomes stiff, making it much more difficult to steer. This can result in loss of control of the vehicle, accidents, serious injuries or death.

- Never let the vehicle roll when the engine is stopped.

WARNING

If the electronic steering lock engages, you can no longer steer the vehicle. This can result in loss of control of the vehicle, accidents, serious injuries or death.

- Never switch off the ignition when the vehicle is in motion.

WARNING

The counter-steering assistance is not a replacement for the driver's attention and works only within the system limitations. In critical driving situations, uncontrolled vehicle movements can occur despite the counter-steering assistance. If you do not pay attention, there is a risk of accidents, serious injuries and death.

- Always stay attentive and do not rely solely on the system. The driver is always responsible for control of the vehicle.
- Ensure that the vehicle is not steered by the counter-steering assistance.
- Always adapt your speed and driving style to the visibility, weather, road and traffic conditions.

Troubleshooting

Steering malfunction

The red warning light turns on or flashes.

There is an electromechanical steering or electronic steering lock malfunction.

Do not continue driving!

1. Contact an authorized Volkswagen dealer or authorized Volkswagen Service Facility for assistance.
 - If the red warning light turns on, it may be difficult to move the steering wheel because the electromechanical steering system is malfunctioning.

Steering malfunction

The yellow indicator light turns on or flashes.

The steering is stiffer or more sensitive than usual.

The indicator light comes on permanently:

1. Restart the engine and drive the vehicle slowly for a short distance.
2. If the indicator light stays on, contact a suitably qualified professional and have the system checked. Volkswagen recommends contacting an authorized Volkswagen dealer or authorized Volkswagen Service Facility.

The indicator light blinks:

1. Turn the steering wheel back and forth slightly.
2. Switch the ignition off and back on.
3. Pay attention to the messages in the instrument cluster display.
4. If the indicator light continues to flash after switching the ignition back on, do not continue driving. Contact an authorized Volkswagen dealer or authorized Volkswagen Service Facility for assistance.

Pedals

Information on the pedals

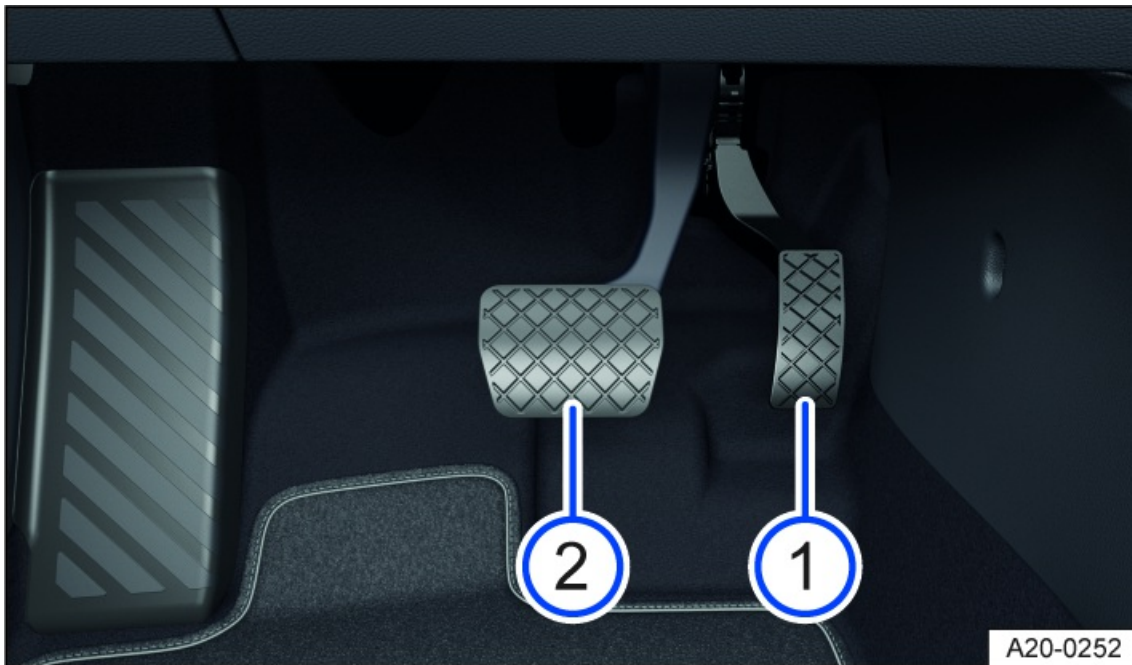

Fig. 90 In the footwell: pedals.

- ① Accelerator pedal.
- ② Brake pedal.

⚠ WARNING

Objects in the driver footwell can prevent the pedals from moving. This can cause the driver to lose control of the vehicle and increases the risk of serious or fatal injuries.

- Make sure all pedals can always be pressed without obstructions.
- Only use suitable floor mats for your vehicle.
- Always attach floor mats securely in the footwell.
- Never place floor mats or other carpet over the installed floor mat.
- Make sure no objects can enter the driver footwell while driving.
- Remove any objects from the footwell when the vehicle is parked.
- Wear shoes that give your feet good grip for operating the pedals.

⚠ WARNING

If a brake circuit is malfunctioning, the brake pedal may need to travel farther in order to stop the vehicle. A longer braking distance could cause accidents and serious or fatal injuries.

- Press the brake pedal down farther if braking power is reduced.

Brakes

Information on the brakes

Breaking in brake pads

During the first approx. 200 to 300 km (approx. 100 to 200 miles), new brake pads do not yet have their full braking efficiency and first need to be “worn in” ⇒ **⚠**. However, you can compensate for the slightly reduced braking force by pressing firmly c



the brake pedal. During the break-in period, the braking distance during full braking or automatic braking is longer than with brake pads that have been broken in. During the break-in period, avoid full braking and situations that place a heavy load on the brakes, such as driving too close to the vehicle ahead.

Brake pad wear

Brake pad wear depends on driving conditions and style. When driving frequently in cities and on curves or with a sporty driving style, have your brake pads checked frequently by suitably qualified professionals. Volkswagen recommends contacting an authorized Volkswagen dealer or authorized Volkswagen Service Facility.

External influences on the brake

When driving with wet brakes, for example after driving through water, in heavy rain, or after washing your vehicle, the braking efficiency can be reduced by moisture or ice on the brake discs. You must “dry” the brakes as soon as possible by braking carefully at high speeds. Ensure that you do not endanger any other vehicles or anyone else on the road ⇒ .

A coating of salt on the brake discs and brake pads reduces the braking efficiency and increases the braking distance. If you do not apply the brakes for long periods of time on salt-covered roads, you must brake carefully to clean off the layer of salt = . Ensure that you do not endanger any other vehicles or anyone else on the road ⇒ .

Leaving the vehicle parked for long periods of time, low mileage, and avoiding heavy braking can contribute to corrosion on the brake rotors and dirty brake pads. If you usually avoid heavy braking or if there is corrosion present, occasional heavy braking at high speeds is recommended to clean the brake rotors and pads. Ensure that you do not endanger any other vehicles or anyone else on the road ⇒ .

WARNING

Driving with worn brake pads or a malfunctioning brake system can lead to a loss of control of the vehicle, accidents and serious or fatal injuries.

- If you suspect that the brake pads are worn or the brake system is malfunctioning, immediately find a suitably qualified professional and have the brake pads checked and worn brake pads replaced. Volkswagen recommends contacting an authorized Volkswagen dealer or authorized Volkswagen Service Facility.

WARNING

Up to the first approx. 300 km (approx. 200 miles), new brake pads do not yet have their full braking efficiency and first need to be “worn in”. Insufficient braking efficiency can increase the risk of accidents. This can cause serious or even fatal injuries.

- Increase the pressure on the brake pedal if reduced braking efficiency can be felt.
- To reduce the risk of accidents, serious injuries, and loss of vehicle control, drive with extra caution when the brake pads are new.
- During the break-in period for new brake pads, do not drive too close to other vehicles and avoid driving situations that place a heavy load on the brakes.

WARNING

Prolonged braking causes the brakes to overheat. This can considerably reduce braking performance, increase braking distance and possibly cause a total brake system malfunction. This can cause a loss of vehicle control, accidents, and serious or fatal injuries.

- Never let the brakes “rub” too often and too long or press the brake pedal too often and too long.

WARNING

When driving downhill, a lot of force is placed on the brakes and they become hot quickly. Overheated brakes reduce the braking efficiency and increase the braking distance considerably. This can cause loss of vehicle control, accidents, and serious or fatal injuries.

- Before starting a journey, ensure that the air supply to the brakes is not covered, e.g. by aftermarket or damaged front spoilers.

WARNING

Wet, icy, or salt-covered brakes will take longer to brake and increase the braking distance. This can cause a loss of vehicle control, accidents, and serious or fatal injuries.

- Test the brakes carefully.
- Press the brake pedal carefully several times to dry the brakes and clear the ice and salt from them, as long as the visibility, weather, road, and traffic conditions permit.

WARNING

When driving at high speed, increased force from the driver may be required to achieve sufficient braking efficiency. Insufficient braking efficiency can increase the risk of accidents and lead to serious or fatal injuries.

- Never exceed the permitted maximum speed.
- Always comply with the applicable driving regulations and speed limits and think ahead while driving.

 Regularly check the thickness of the brake pads visually by inspecting them through the openings in the wheel rims or from underneath the vehicle. If necessary, remove the wheels so that the brake pads can be inspected. Volkswagen recommends contacting an authorized Volkswagen dealer or authorized Volkswagen Service Facility.

Troubleshooting

BRAKE Brake system malfunction

The red warning light turns on. A message may also be displayed.

1.  **Do not continue driving!** Contact an authorized Volkswagen dealer or authorized Volkswagen Service Facility immediately for assistance.

BRAKE WEAR Brake pad wear indicator

The red warning light turns on or flashes.

The front brake pads are worn.

1. Immediately contact an authorized Volkswagen dealer or authorized Volkswagen Service Facility to have the system checked. Volkswagen recommends contacting an authorized Volkswagen dealer or authorized Volkswagen Service Facility.
2. Have all brake pads inspected and replaced, if necessary.

Unusual noises when braking

If there are sustained scraping or squeaking noises when braking, that is a sign of worn brake pads on the front or rear axle.

1. Immediately contact an authorized Volkswagen dealer or authorized Volkswagen Service Facility to have the system checked. Volkswagen recommends contacting an authorized Volkswagen dealer or authorized Volkswagen Service Facility.
2. Have all brake pads inspected and replaced, if necessary.

If the vehicle's braking performance changes

If the brake pads are worn or if you notice that your vehicle does not brake as usual, e.g. the braking distance suddenly increases:

1. Immediately contact an authorized Volkswagen dealer or authorized Volkswagen Service Facility to have the system checked. Volkswagen recommends contacting an authorized Volkswagen dealer or authorized Volkswagen Service Facility.
2. Have all brake pads inspected and replaced, if necessary.

Start the engine



Remote start relay function

With the remote start relay function, the engine can be started remotely, in order to heat or cool the vehicle interior before the start of a journey.

The use of the remote start relay function may be regulated or prohibited regionally in some countries. Always observe legal and local regulations relating to the use of the remote start relay function.

Remote start relay conditions

The following conditions must be fulfilled simultaneously in order for the vehicle interior to be heated or cooled by the remote start relay function:

- ✓ The vehicle is fully ready to drive.
- ✓ The vehicle does not move.
- ✓ Sufficient fuel is available and the indicator light  did not light up before the vehicle was parked.
- ✓ The parking lock  is engaged.
- ✓ All doors, the hood and the trunk lid are fully closed and locked.
- ✓ The anti-theft alarm system has not triggered the alarm.
- ✓ The panic alarm is not activated.
- ✓ The emergency flashers are switched off.
- ✓ Two remote starts have not yet been carried out in direct succession.

Starting the Remote Start Relay Function

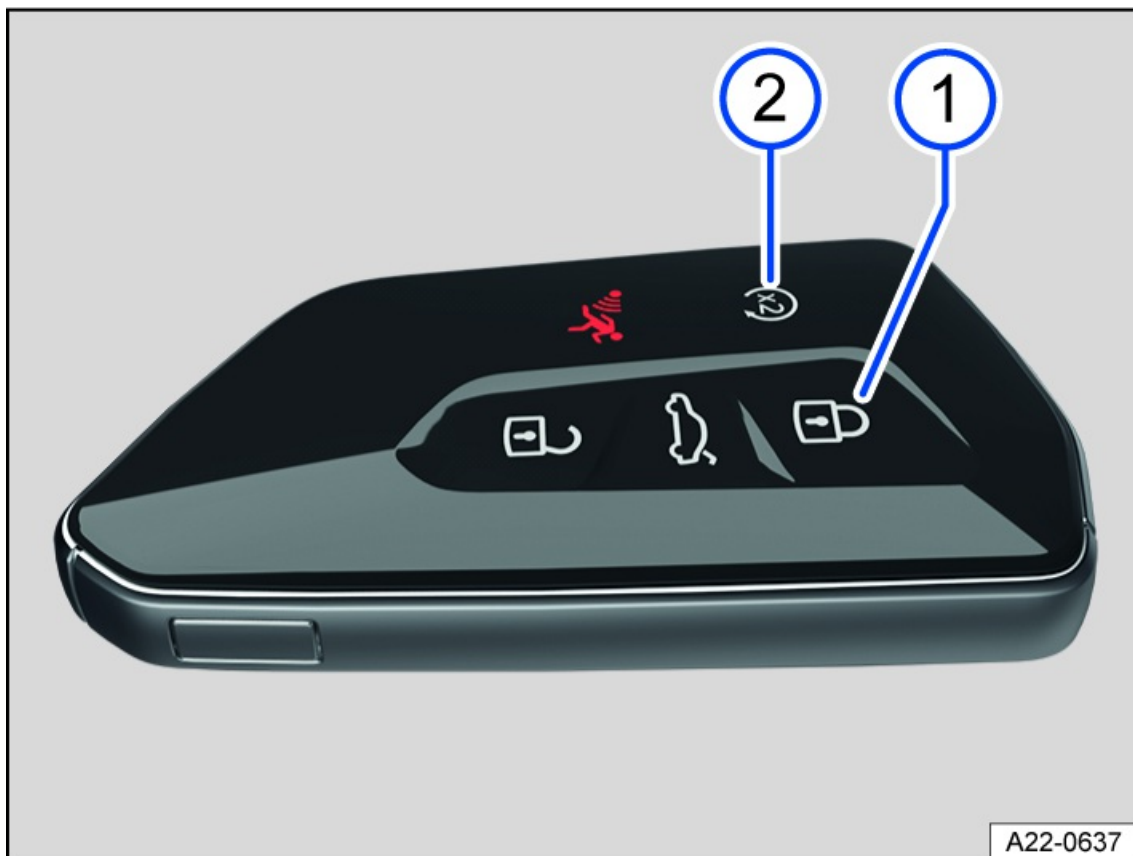





Fig. 91 On the remote control vehicle key: Button for remote start relay function.

- ① Button to lock the vehicle.
- ② Button for remote start relay function.

To start the engine with the remote start function, you must press the following buttons on the vehicle key within five seconds
 ⇒ ⚠:

1. Press the button  once *fig. 91*.
 All turn signals will flash.
2. Press the  button twice *fig. 91*.
 All turn signals will flash. During remote start, the parking light turns on.

 For vehicles with Keyless Access, all valid vehicle keys which are in the vehicle interior have been blocked for this period of time.

If the remote start relay process is not actively canceled by the driver or automatically canceled, the engine will run for around 10 minutes. A maximum of two remote starts can be performed in a row, even if one or both remote starts have been interrupted within the 10 minute period.

1. In order to carry out two more remote starts, switch the ignition on and off once.

Ending the remote start relay

1. Press the  button on the remote control vehicle key to switch off the engine *fig. 91*.

Driving after a remote start relay

To be able to drive the vehicle after you have used the remote start relay function, you have to start the vehicle separately.

1. Vehicles with starter button: Press the brake pedal and the starter button.

The engine continues to run during this process.

Settings for automatic air conditioning with remote start relay

Climatronic: After the engine is started, the air conditioner automatically regulates the temperature of the vehicle interior to approx. +22 °C (approx. +72 °F) if it is in automatic mode **AUTO**.

If the engine has been started using the remote start relay function, the settings can be changed via the air conditioning system controls and the buttons for the windshield and rear window defroster, seat heating or ventilation, depending on the vehicle equipment.

Personal settings will be replaced by the automatic air conditioning settings the next time the vehicle is started using remote start relay.

1. To change the automatic air conditioning settings, contact a suitably qualified professional. Volkswagen recommends contacting an authorized Volkswagen dealer or authorized Volkswagen Service Facility.

Automatic remote start relay functions

Depending on the outside temperature and vehicle equipment, the following heating, ventilation and cooling system settings are automatically activated in the case of a remote start relay:

- Heated spray jets for windscreen washer system.
- Heated windshield wiper parks.
- Rear window defroster.
- Exterior mirror heating.
- Steering wheel heating.
- Front seat heating.
- Front seat ventilation.

WARNING

Careless or unsupervised use of the remote start relay function may cause poisonous gases to enter the vehicle interior. This can cause serious injuries and death due to asphyxiation.

- Never start the engine in an enclosed space, e.g. in a garage.
- Only use the remote start relay function when no-one is in the vehicle and immediately before you intend to drive the vehicle.

WARNING

When the engine is running, the electrical seats are operational. There is a risk of crushing and serious injuries.

- Never start the engine if children or animals are in the vehicle unsupervised.
- Never start the engine if the vehicle is out of visual range.

WARNING

Hot vehicle parts and exhaust can ignite flammable or explosive materials in the vicinity. This can lead to a fire and cause accidents and serious or fatal injuries.

- Never start the engine close to flammable or explosive materials.
- Never start the engine if the vehicle is covered with a protective cover.
- Never start the engine if the vehicle is out of visual range.

- Never start the engine if the warning light  is turned on or blinking.

 Using the remote start relay function may increase fuel consumption and discharge the 12 V vehicle battery.

 During an active remote start relay, some vehicle functions are deactivated, e.g. the low beam headlight and the windshield wipers.

Electronic immobilizer

The immobilizer helps prevent the engine from being started and the vehicle from being moved with an unauthorized vehicle key.

Vehicles with a Starter Button

In the remote control vehicle key, there is a chip used to automatically deactivate the electronic immobilizer when there is a valid remote control vehicle key in the vehicle interior.

The electronic immobilizer is automatically engaged as soon as the ignition is switched off ⇒ *Starter button*.

 You can only start the engine with a suitably coded Volkswagen Original vehicle key. You can obtain coded vehicle keys from an authorized Volkswagen dealer or authorized Volkswagen Service Facility.

Starter button

The starter button replaces the ignition lock (Press & Drive).

Start the engine with the starter button and by pressing the brake pedal.

The vehicle can only be activated when there is a valid vehicle key inside the vehicle.

Depending on the vehicle equipment, the function readiness is indicated by the starter button blinking.

The electronic steering lock is activated when you leave the vehicle by opening the driver door when the ignition is switched c (depending on the country and the vehicle equipment) ⇒ *Steering information*.

Switching the ignition on or off



Fig. 92 In the lower section of the center console: starter button.

1. Press the starter button *fig. 92* once without pressing the brake pedal ⇒ .

Automatic ignition switch off

If the vehicle recognizes that the driver is absent when the internal combustion engine is switched off, the ignition is automatically switched off after a certain amount of time.

Engine restart function

If no valid remote control vehicle key is detected in the vehicle interior after the engine has been inadvertently switched off, the engine cannot be started within approximately five seconds.

Once this time has elapsed, the vehicle can no longer be started without a valid vehicle key inside the vehicle.

WARNING

If the brake pedal is pressed when switching on the ignition, the engine will start immediately. This can cause unintentional vehicle movement and serious injuries.

- Avoid pressing the brake pedal when switching on the ignition if you do not intend to start the engine.

WARNING

If you leave vehicle keys unattended in the vehicle, children or unauthorized people could lock the doors and/or the trunk lid, start the engine, or switch on the ignition and thereby activate electrical equipment, such as the power windows. This can cause accidents and serious or fatal injuries.

- Always take all vehicle keys with you when leaving the vehicle.

WARNING

If you leave children, people requiring assistance or animals unattended in the vehicle, they may accidentally set the vehicle in motion or be subjected to very high or low temperatures. There is a risk of accidents and serious or fatal injuries.

- Never leave children, people requiring assistance or animals unattended in the vehicle.

 Always switch the ignition off manually before leaving the vehicle and note any messages in the instrument cluster display.

 The vehicle being stationary for long periods with the ignition switched on can cause the 12 V vehicle battery to drain and then it will not be possible to start the engine.

Start the engine

Start the engine

1. Switch the ignition on.
2. Set the electronic parking brake.
3. Vehicles with an automatic transmission: Press and hold the brake pedal until the engine has started. Engage gear **N** or the parking lock **P**.
4. Press the starter button briefly ⇒ *Starter button*. Do not press the accelerator pedal during this process. A valid vehicle key must be inside the vehicle for the engine to start.

5. If the engine does not start, stop the starting procedure and try again after approximately one minute.
6. If the vehicle was locked with the vehicle key, the starter button will be deactivated. If you are in the vehicle and you need to start the engine, unlock the vehicle first or perform an emergency start.

WARNING

Starting the engine in unventilated or enclosed spaces may cause poisonous gases to enter the vehicle interior. This can cause serious injuries and death due to asphyxiation.

- Never start the engine or let it run in unventilated or enclosed spaces, such as in garages.

WARNING

Hot vehicle parts and exhaust can ignite flammable or explosive materials in the vicinity. This can lead to fires and cause accidents and serious or fatal injuries.

- Never start the engine or leave the engine running if oil, fuel or other flammable operating equipment is in the vicinity of the vehicle or is escaping from the vehicle.
- Do not use any start boosters.

WARNING

An unattended vehicle which is ready to drive may cause accidents and severe injuries.

- Never leave the vehicle unattended when the engine is running, especially if a gear is engaged.

NOTICE

Incorrect handling of the vehicle can increase wear to components, such as the engine or starter, or cause damage.

- Avoid restarting the engine while driving or directly after turning off the engine.
- Avoid high engine speeds, harsh acceleration and heavy engine loads when the engine is cold.
- Be aware that at high altitudes, the air density is lower, which can make it more difficult to start the engine.

NOTICE

Uncombusted fuel can damage the catalytic converter.

- Do not tow-start or push-start the vehicle.

 Do not let the engine run to warm up while the vehicle is parked. Begin driving as soon as there is enough visibility through the windows. This allows the engine to reach its operating temperature sooner and reduces the emissions.

 Larger electrical equipment is temporarily switched off when the engine is started.

 If there is no vehicle key in the vehicle or the key is not detected, a message will appear in the instrument cluster display. This can occur if another signal interferes with the remote control vehicle key or if the remote control vehicle key is covered by an object, such as a metal case.

 For example, if the vehicle key button cell battery is weak or drained, the engine cannot be started with the starter button. If this is the case, use the emergency start function.

 After starting, operating noises may be temporarily higher than usual while the engine is cold. This is normal and not a cause for concern.

Troubleshooting

Engine control malfunction

The red warning light turns on.

The vehicle's drive power may be limited or not present at all. It may not be possible to continue driving, or only with limitations.

Do not continue driving!

1. Safely park the vehicle.
2. Pay attention to the message in the instrument cluster display.
3. See an authorized Volkswagen dealer or authorized Volkswagen Service Facility for assistance and have the engine control checked.

Engine control malfunction

The yellow indicator light turns on.

The vehicle's drive power may be limited.

1. The message Error: Drive system. Please service vehicle. appears on the instrument cluster display.
2. Have the engine checked immediately by a suitably qualified professional. Volkswagen recommends contacting an authorized Volkswagen dealer or authorized Volkswagen Service Facility.

Engine control malfunction

The yellow indicator light turns on.

The driving performance has been limited to prevent the engine control components from overheating.

- The message Error: Drive system. Vehicle performance is limited. appears on the instrument cluster display.
- It is possible to continue driving with reduced driving performance.

The driving performance limitation is removed in the following scenarios:

- The engine control components are no longer within a critical temperature range.

Engine speed limited

The yellow indicator light turns on.

The engine speed has been limited to reduce the risk of the engine overheating. The instrument cluster display also shows the RPM.

The engine speed limitation is removed in the following scenarios:

- The engine is no longer within a critical temperature range.
- You take your foot off the accelerator pedal.

together with Engine speed limitation due to engine control malfunction

The yellow indicator lights turn on.

The engine speed limitation is triggered by an engine control malfunction.

The drive system's power may be limited.

1. Make sure the displayed RPM is not exceeded.
2. Have the engine checked immediately by a suitably qualified professional. Volkswagen recommends contacting an authorized Volkswagen dealer or authorized Volkswagen Service Facility.

Valid vehicle key cannot be detected



Fig. 93 In the lower section of the center console: emergency start function.

A corresponding indicator appears in the instrument cluster display.

If the remote control vehicle key has a weak or drained button cell battery, the vehicle key may not be able to be detected.

An emergency start must be performed:

1. Press and hold the brake pedal.
2. Place the vehicle key on the mat with the key symbol *fig. 93* (arrow) and press the starter button.

The ignition will switch on automatically and the engine may start.

The engine cannot be started

If an unauthorized vehicle key is used or the system is malfunctioning, a corresponding indicator appears in the instrument cluster display.

1. Use an authorized vehicle key.
2. If the malfunction persists, contact an authorized Volkswagen dealer or authorized Volkswagen Service Facility.

The engine cannot be started remotely

If the engine cannot be started remotely, there may be a system error or the conditions for a remote engine start may not be

met:

1. Ensure that all of the necessary conditions are met and then restart the engine if necessary ⇒ *Remote start relay function*
2. If the engine still will not start remotely, contact a suitably qualified professional. Volkswagen recommends contacting an authorized Volkswagen dealer or authorized Volkswagen Service Facility.

Stopping the engine

Stopping the engine

1. Bringing the vehicle to a stop ⇒ .
2. Park the vehicle.
3. Press the starter button briefly. If the engine cannot be turned off, use the emergency stop function.
4. Pay attention to the messages in the instrument cluster.

Car wash function

Vehicles with an automatic transmission: If the ignition is switched off in gear **N**, the vehicle will be capable of rolling for 30 minutes. After this time, the parking lock **P** is automatically engaged when the vehicle is stationary. Approximately one minute before the parking lock **P** is automatically engaged, a corresponding message is shown in the instrument cluster display.

Exit warning

When the driver door is opened, a warning chime sounds and warning notifications appear in the instrument cluster display to warn you that you are exiting a vehicle that can roll.

Water vapor in cold and wet weather

When the vehicle is stopped after driving in cold and wet weather, water vapor may come out of the radiator grille for a short time. The formation of water vapor on hot engine components is normal and does not constitute a technical malfunction.

WARNING

When the engine is switched off, certain vehicle systems do not work or only work in a limited way, such as the brake booster or power steering. As a result, you must use more force for steering and you must apply more pressure on the brake pedal to stop. When the vehicle is moving, this can result in loss of control of the vehicle, accidents and serious or fatal injuries.

- Never switch off the engine while the vehicle is in motion.

WARNING

When the engine is switched off, the airbags and safety belt pretensioners will not function. This can cause serious or fatal injuries in the event of accidents.

- Never switch off the engine while the vehicle is in motion.

WARNING

If the ignition is switched off, the steering lock can engage and you would no longer be able to steer the vehicle. When the vehicle is moving, this can result in loss of control of the vehicle, accidents and serious or fatal injuries.

- Never switch off the ignition when the vehicle is in motion.

WARNING

The parts of the exhaust system become very hot and can ignite flammable materials, for example shrubs, leaves, dry grass or spilled fuel. This can lead to a fire and cause accidents and serious or fatal injuries.

- Never park the vehicle in such a way so that the exhaust system components come into contact with flammable materials under the vehicle.
- Never use additional undercoating or corrosion protection for exhaust pipes, catalytic converters, heat shields, or particulate filters.

NOTICE

The engine can overheat after turning it off if the vehicle is driven with a high engine load for a long period of time.

- Let the engine run in neutral for approximately two minutes before turning it off.

 The radiator fan in the hood space may continue running for several minutes after the engine has been switched off, even if the ignition is switched off. The radiator fan turns off automatically.

Troubleshooting

The engine cannot be turned off

The engine cannot be turned off when the starter button is pressed briefly.

An emergency stop must be performed:

1. Press the starter button twice within several seconds or press and hold one time.

The engine switches off automatically ⇒ *Starter button*.

Start/Stop system

Start-stop system

Function description

The start-stop system automatically switches the engine off shortly before and when the vehicle comes to a halt and when stationary.

The engine always restarts automatically when required for the vehicle and the identified situation.

Indicator lights

The start-stop system status can be displayed in the instrument cluster display.

When indicator light  comes on, the start-stop system is available and the automatic engine stop is active.

When indicator light  comes on, the start-stop system is not available.

Conditions for Automatically Restarting the Engine

- If you take your foot off the brake pedal or you press the accelerator pedal.
- If the vehicle interior heats up or cools down significantly.

- If the vehicle starts to move.
- If the electrical voltage in the 12-volt vehicle battery falls.

Conditions that Can Prevent Automatic Engine Shutdown

- The driver is not wearing their safety belt.
- The driver door is opened.
- The engine hood is open.
- A minimum engine temperature has not been reached.
- The temperature in the vehicle interior is not within the preset temperature values or the humidity is too high.
- The air conditioner's defrost function is switched on.
- The charge level of the 12 V vehicle battery is insufficient.
- The temperature of the 12 V vehicle battery is too low or too high.
- The vehicle is on a large uphill or downhill gradient.
- The steering wheel is significantly turned.
- The reverse gear is engaged.
- Park Assist is activated.
- Selector lever position **S** is engaged.

If the conditions for automatic engine switch-off are only achieved during a stationary phase, then the engine may also switch off at this point, e.g. if the defrost function is switched off.

Manually deactivating and activating the start-stop system

The start/stop system can be manually deactivated and activated in the Infotainment system.

The function is automatically activated every time the ignition is switched on.

Manually deactivating the start-stop system:



1. Tap the **(Vehicle)** function key in the menu selection.
2. Tap the **(Status)** function key.
3. Tap the **(^A OFF Start-stop)** function key to deactivate the start-stop system. If the start-stop system is deactivated, the **(^A OFF Start-stop)** function key will have a color background.

 Always manually deactivate the start-stop system when driving through water.

Manually activating the start-stop system:

1. Tap the **(Vehicle)** function key in the menu selection.
2. Tap the **(Status)** function key.
3. Tap the **(^A OFF Start-stop)** function key to activate the start-stop system.

If the start-stop system has switched off the engine, it will start again as soon as the system is deactivated with the **(^A OFF Start-stop)** function key.

 In some cases, you may need to restart the engine manually, e.g. if the hood is opened. Pay attention to the relevant message on the instrument cluster display ⇒ .

 For case of vehicles with Driving Mode Selection, the start-stop system is automatically activated if the Eco driving mode is

selected.

WARNING

If the start-stop system is activated during work in the hood space, the engine may start suddenly. This can cause accidents and serious injuries.

- Always deactivate the start-stop system when working in the hood space.

WARNING

With the ignition switched off, certain vehicle systems do not work or only work in a limited way, such as the brake booster or power steering. As a result, you must use more force for steering and you must apply more pressure on the brake pedal to stop. When the vehicle is moving, this can result in loss of control of the vehicle, accidents and serious or fatal injuries.

- Never switch off the ignition when the vehicle is in motion.

WARNING

With the ignition switched off, the airbags and safety belt pretensioners will not function. This can cause serious or fatal injuries in the event of accidents.

- Never switch off the ignition when the vehicle is in motion.

WARNING

If the ignition is switched off, the steering lock can engage and you would no longer be able to steer the vehicle. When the vehicle is moving, this can result in loss of control of the vehicle, accidents, and serious or fatal injuries.

- Never switch off the ignition when the vehicle is in motion.

NOTICE

If the start-stop system is used for a very long period of time at very high outside temperatures, this can damage the 12-volt vehicle battery.

- Avoid using the start-stop system at very high outside temperatures.

Troubleshooting



The engine no longer starts automatically

The red warning light turns on.

There is a start-stop system malfunction.

1. Start the engine manually ⇒ *Start the engine*.
2. Contact an authorized Volkswagen dealer or authorized Volkswagen Service Facility immediately. Volkswagen recommends contacting an authorized Volkswagen dealer or authorized Volkswagen Service Facility.

Automatic transmission

Selector lever

When the ignition is switched on, the gear position that is currently engaged is shown on the instrument cluster display and on the selector lever.

Selecting a selector lever position

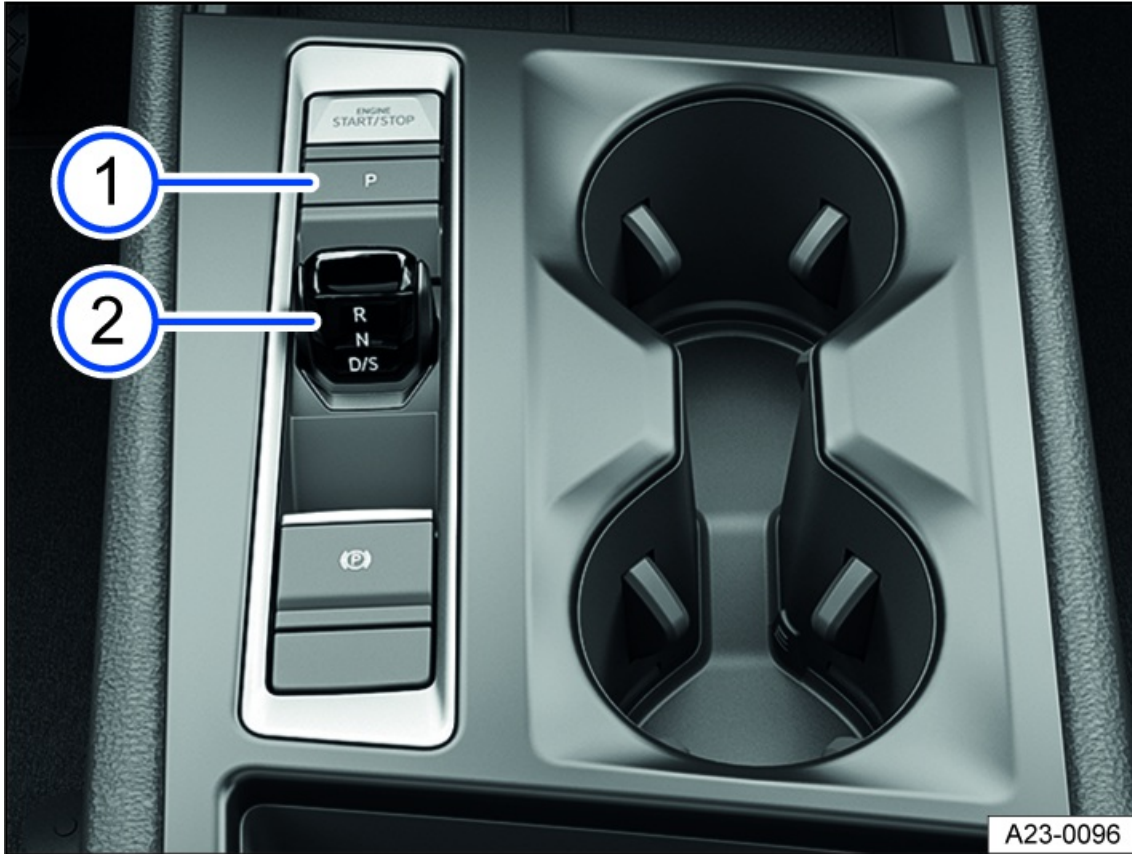

Fig. 94 In the center console: selector lever of the automatic transmission.

- ① Button for the parking lock.
- ② Selector lever.

To change into gear from neutral position **N**, proceed as follows:

1. Start the engine.
2. Press the brake pedal.
3. Push the selector lever in the desired direction *fig. 94* ②.

Changing gear

When operating the brake or selecting a gear, the gear shift pattern is displayed in the instrument cluster.

To select the nearest selector lever position, move the selector lever backward or forward to the first pressure point. The selector lever will then return to its starting position.

To skip a selector lever position, move the selector lever beyond the pressure point and in the direction you require. The selector lever will then return to its starting position. It is therefore possible to switch directly from gear **D** to gear **R**, for example. This skips gear **N**.

Description of the selector lever positions

PThe drive gears are locked. Only select this gear when the vehicle is stationary.

To engage the parking lock, press the **P** button *fig. 94* ①.

If the engine is switched off while in the **D/S** or **R** gear, the **P** transmission position is automatically engaged and the vehicle prevented from rolling away.

R Reverse gear is selected. Only select this gear when the vehicle is stationary. **N** The transmission is in the neutral setting. No power is transferred to the wheels and the engine braking effect is not available.

If the engine is switched off when selector lever position **N** is selected, the transmission remains in neutral position **N** for approximately 30 minutes and only then activates the parking lock **P** (car wash function) ⇒ *Stopping the engine*.

D/S gear: normal program.

The transmission upshifts and downshifts automatically when in the forward driving gears. The shifting time depends on the engine load, the personal driving style, and the driving speed.

S gear: sport program.

The forward gears automatically upshift later and downshift earlier than in **D** gear in order to fully utilize the engine power reserves. The shifting time depends on the engine load, the personal driving style, and the driving speed.

To switch between gears **D** and **S**, tap the selector lever toward the rear.

The selector lever will always spring back to the center position.

WARNING

If the brake pedal is released while the engine is running and gear **D/S** or **R** is engaged, the vehicle will start moving. This can cause unintentional vehicle movement and accidents and serious injuries.

- When the engine is running and the **D/S** or **R** gear is engaged, hold the vehicle with the brake pedal.
- As the driver, never leave the driver seat when the engine is running and a gear is engaged.
- If you have to leave the vehicle while the engine is running, always set the electronic parking brake and move the selector lever to the **P** position.

WARNING

Engaging the incorrect gear can cause you to lose control of the vehicle, which could lead to an accident and serious or fatal injuries.

- Never press the accelerator pedal while engaging a gear.
- Never shift into reverse gear **R** or engage the parking lock **P** while the vehicle is moving.

WARNING

If the vehicle is left in selector lever position **N** on inclines, the vehicle will roll downhill even if the engine is switched on. This can cause accidents and serious injuries.

- Never leave the vehicle in selector lever position **N**.

NOTICE

If the electronic parking brake is not switched on when the vehicle is stationary and the brake pedal is released when the parking lock **P** is engaged, the vehicle may move forward or backward a few inches. This can cause damage to the vehicle.

- Always set the electronic parking brake first before releasing the brake pedal.

i If you accidentally switch to **N** while driving, you should take your foot off the accelerator pedal and wait for the engine to idle in neutral position. Only then should you shift into a gear.

Shifting using tiptronic

The tiptronic mode allows you to shift gears manually on an automatic transmission.

You can switch to the tiptronic program from gears **D** and **S** by pulling a shift paddle *fig. 95*.

The tiptronic program is switched on temporarily from gear **D**.

The tiptronic program is switched on permanently from gear **S**.

When shifting in the tiptronic program, the gear currently engaged is maintained. This applies until the system shifts gears automatically when the speed threshold is reached.

Once the gearbox has switched to the Tiptronic program, this is indicated in the instrument cluster display with **M**.

If the engine is switched off while the gearbox is in Tiptronic mode, the gearbox engages the electronic parking brake **P**. The vehicle is secured from rolling away.

Operating Tiptronic with the shift paddles



Fig. 95 Behind the steering wheel: shift paddles for the tiptronic.

- To shift up a gear, pull the right-hand shift paddle toward the steering wheel *fig. 95*.
- To shift down a gear, pull the left-hand shift paddle toward the steering wheel *fig. 95*.
- To engage the lowest gear, pull the left-hand shift paddle toward the steering wheel and hold it there.

i When accelerating, the transmission automatically upshifts to the next gear shortly before the maximum permissible engine RPM is reached.

i When downshifting manually, the transmission only shifts if it is no longer possible to over-rev the engine.

Leaving the tiptronic program

1. Exits automatically after 8 seconds if the tiptronic program was initiated from gear **D**.

Or: Pull the right-hand shift paddle towards the steering wheel for about three seconds and release again.

Or: engage **D** position.

Driving with an automatic transmission

The transmission shifts up and down automatically when in the forward driving gears.

Driving on an incline

The steeper the incline, the lower the gear that you should select. Lower gears increase the engine braking effect. Never let the vehicle roll down mountains or hills in the **N** neutral setting.

1. Reduce your speed.
2. Switch the transmission to tiptronic mode.
3. Downshift using the shift paddles on the steering wheel.

Stopping and starting to drive uphill

The steeper the hill, the lower the gear that you should select.

If you stop on a hill with a gear selected, always press the brake pedal or set the electronic parking brake to prevent the vehicle from rolling away. Only release the brake pedal or the electronic parking brake once you start driving.

Kick-down

The kick-down function makes maximum acceleration possible in the **D** and **S** gears or in tiptronic mode.

When you press the accelerator pedal all the way down, the automatic transmission downshifts into a lower gear, depending on the vehicle speed and engine speed. This utilizes the full acceleration power of the vehicle ⇒ .

With the kick-down function, the automatic upshift to the next gear only occurs if the maximum predefined engine RPM is reached.

If the Eco driving mode is selected and the accelerator pedal is fully pressed past the pressure point, engine performance is controlled automatically so that the vehicle achieves maximum acceleration.

WARNING

Fast acceleration or switching off ASR or ESC or activating ESC Sport can cause traction loss and sliding. This could cause loss of vehicle control, accidents, and serious or fatal injuries, especially on slippery roads, such as on wet, icy or dirty roads.

- Always adapt your driving style to the flow of traffic.
- Only use the kick-down function, Launch Control Program or accelerate quickly when the visibility, weather, road, and traffic conditions allow it, and when other road users will not be endangered by the vehicle's acceleration and driving style.
- Switch ASR or ESC back on or switch ESC Sport back off after acceleration.

WARNING

Prolonged braking causes the brakes to overheat. This can considerably reduce braking performance, considerably increase braking distance and possibly lead to a total brake system malfunction. Accidents and serious or fatal injuries could result.

- Never let the brakes “rub” too often and too long or press the brake pedal too often and too long.

NOTICE

If the vehicle rolls with the engine switched off, the transmission is not lubricated. This can cause the automatic transmission to overheat and can damage it.

- If you stop on inclines when a gear is engaged, use the brakes and not the accelerator pedal to hold the vehicle.
- Never let the vehicle roll in **N** gear, especially when the engine is stopped.

NOTICE

If the brake pads “rub” when the brake pedal is pressed lightly, wear is increased.

- Never let the brakes “rub” by pressing the pedal lightly when braking is not really necessary.

Troubleshooting

The engine is not starting

The green indicator light turns on.

The brake pedal was not pressed, for example when trying to shift to another gear using the selector lever.

1. Press the brake pedal to select a gear.

Transmission in emergency mode

The yellow indicator light turns on.

An audible warning may also sound. Where applicable, a message will appear in the instrument cluster display.

There is a malfunction in the system and the automatic transmission is running in an emergency mode. In some cases, it is not possible to select reverse gear.

1. Contact an authorized Volkswagen dealer or authorized Volkswagen Service Facility immediately. Volkswagen recommends contacting an authorized Volkswagen dealer or authorized Volkswagen Service Facility.

Risk of rolling away! **P** unavailable

The yellow indicator light turns on.

An audible warning may also sound. Where applicable, a message will appear in the instrument cluster display.

There is a malfunction in the system and the parking lock cannot be engaged.

1. When the vehicle is parked, check that the electronic parking brake is switched on.
2. Contact an authorized Volkswagen dealer or authorized Volkswagen Service Facility for assistance.

Selector lever malfunction

The yellow indicator light turns on.

An audible warning may also sound. Where applicable, a message will appear in the instrument cluster display.

There is a malfunction in the selector lever.

1. Contact a suitably qualified professional. Volkswagen recommends contacting an authorized Volkswagen dealer or authorized Volkswagen Service Facility.

Transmission overheating

The yellow indicator light turns on.

An audible warning may also sound. Where applicable, a message will appear in the instrument cluster display.

The automatic transmission can become too hot, for example due to frequently starting up on slopes.

1. At the next opportunity, stop and let the transmission cool down with the parking lock **P** engaged and the engine running ⇒ .
2. If the indicator light does not turn off, switch on the electronic parking brake and leave the vehicle stationary.
3. Contact an authorized Volkswagen dealer or authorized Volkswagen Service Facility for assistance. Otherwise, the transmission could become severely damaged.

Transmission malfunction

The yellow indicator light turns on.

An audible warning may also sound. Where applicable, a message will appear in the instrument cluster display.

There is a problem in the transmission.

1. Contact a suitably qualified professional. Volkswagen recommends contacting an authorized Volkswagen dealer or authorized Volkswagen Service Facility.

Transmission malfunction

The red warning light turns on.

An audible warning may also sound. Where applicable, a message will appear in the instrument cluster display.

There is a serious fault in the transmission.

Do not continue driving!

1. Stop the vehicle as soon as it is safe to do so.
2. Engage the parking lock.
Or: switch on the electronic parking brake.
3. Contact an authorized Volkswagen dealer or authorized Volkswagen Service Facility for assistance.

Transmission overheating

The red warning light turns on.

An audible warning may also sound. Where applicable, a message will appear in the instrument cluster display.

The automatic transmission can become too hot, for example due to frequently starting up on slopes.

Do not continue driving!

1. Let the transmission cool down with the parking lock **P** engaged and the engine running ⇒ .
2. If the indicator light does not turn off, switch on the electronic parking brake and leave the vehicle stationary.
3. Contact an authorized Volkswagen dealer or authorized Volkswagen Service Facility for assistance. Otherwise, the transmission could become severely damaged.

Emergency release of the parking lock

If there is a loss of power, for example due to the 12 V vehicle battery being drained, and the vehicle should be towed, then the selector lever lock must be released manually.

1. Contact an authorized Volkswagen dealer or authorized Volkswagen Service Facility for assistance.

Vehicle is not moving even when a drive gear is engaged

If the vehicle does not move in the desired direction, the system may not have engaged the drive position correctly.

1. Press the brake pedal and select the drive position again.
2. If the vehicle still does not move in the desired direction, there is a system malfunction. See an authorized Volkswagen dealer or authorized Volkswagen Service Facility for assistance to have the system checked.

WARNING

If the parking lock **P** is released and the electronic parking brake is switched off, the vehicle may start to move unexpectedly on inclines or hills. This can cause accidents and serious injuries.

- Never release the parking lock **P** once the electronic parking brake is switched off.

NOTICE

If the vehicle rolls with the engine off and the selector lever in position **N** for a long period of time or at high speed, the automatic transmission will be damaged.

- Do not allow the vehicle to roll for a long period of time or at high speed with the engine off and in the **N** gear, e.g. in the case of towing.

NOTICE

If the transmission gets too hot or overheats, this may lead to increased wear or damage to the component.

- Avoid starting the vehicle and driving slowly, like at walking speed, while the transmission is overheated.
- Drive faster than approx. 20 km/h (approx. 12 mph) or immediately stop the vehicle safely the first time the vehicle indicates that the transmission is overheating.
- Stop the vehicle safely as soon as possible and switch off the engine if the message and audible warning are repeating approximately every 10 seconds.
- Let the transmission cool down.
- Only start driving again when the audible warning is no longer sounding.

Braking assistance systems

Information about braking assistance systems

Braking assistance systems can stabilize the vehicle in critical driving or braking situations and increase driving safety. The driver is always responsible for safe driving ⇒ .

- If a braking assistance system is regulating, continue braking with the necessary force.
- If necessary, steer the vehicle.

WARNING

Braking assistance systems cannot replace the driver's attention and can only operate within the limitations of the system. Fast driving on icy, slippery, or wet roads, as well as following the vehicle ahead too closely, may impair the vehicle

stability and cause you to lose control of the vehicle. If you are careless, there is a risk of accidents, serious injuries and death.

- Always stay attentive and do not rely solely on the system. The driver is always responsible for control of the vehicle.
 - Always adapt your speed and driving style to the visibility, weather, road and traffic conditions. Do not take any risks.
 - Always keep the footwell beneath the pedals clear so that the brake pedal is unobstructed and can move freely.
 - Always use suitable tires, as driving stability depends on the tires' ability to grip the road.
-
- ESC, ABS and ASR only function correctly when all four wheels have the intended tires ⇒ .
 - If the ABS malfunctions, the ESC, ASR and EDL also fail.

When the ignition is switched on, the condition of the braking functions is automatically checked. The indicator lights will come on briefly and then turn off. If an indicator light remains on permanently, there is a malfunction. Contact an authorized Volkswagen dealer or authorized Volkswagen Service Facility immediately. Volkswagen recommends contacting an authorized Volkswagen dealer or authorized Volkswagen Service Facility.

WARNING

The effectiveness of the ESC may be reduced considerably if other components and systems that affect driving dynamics have not been maintained correctly or are malfunctioning. This applies especially to changes to the suspension and unapproved rim/tire combinations. Accidents and serious or fatal injuries could result.

- Ensure that conversion and modifications to the vehicle are only performed by an authorized Volkswagen dealer or authorized Volkswagen Service Facility. Volkswagen recommends contacting an authorized Volkswagen dealer or authorized Volkswagen Service Facility.
- Always use suitable tires, as driving stability depends on the tires' ability to grip the road.

Electronic Stability Control (ESC)



ESC is regulating the vehicle to reduce the risk of skidding and improve driving stability ⇒ . The indicator light flashes yellow.

Anti-Slip Regulation (ASR)



ASR is regulating the vehicle to reduce the risk of the wheels spinning. The indicator light flashes yellow.

ASR reduces drive power at wheels that are spinning and adapts the drive power to the road conditions. ASR makes it easier to start, accelerate, and drive up hills ⇒ .

Anti-Lock Brake System (ABS)

ABS prevents the wheels from locking during braking so that the vehicle can be steered ⇒ .

Brake Assist System (BAS)

BAS can help to reduce the vehicle braking distance. When the driver presses the brake pedal quickly in emergency situations, BAS increases braking force ⇒ .

Electronic Differential Lock (EDL and XDL)

EDL automatically applies the brakes to a wheel that starts spinning and transfers the drive power to the other driving wheels.

XDS is an extension of the electronic differential lock, and improves traction with braking support to help keep the vehicle in it

lane.

Multi Collision Brake

If the airbag control module has detected a collision in an accident situation, the Automatic Post-Collision Braking System automatically brakes the vehicle.

Requirements for automatic braking:

- ✓ You are not pressing the accelerator pedal.

Brake booster

The braking support only functions when the engine is running and it enhances the pressure applied to the brake pedal by the driver.

If the brake booster is not in operation or the vehicle is being towed, you will need to press the brake pedal harder because the lack of braking assistance will increase the braking distance ⇒  , ⇒ [Troubleshooting](#).

WARNING

Driving without the brake booster or when the brake booster's system function is limited can increase the braking distance significantly. This may lead to accidents resulting in serious or fatal injuries.

- Never stop the engine or switch the ignition off while the vehicle is moving.
- Press the brake pedal harder if the brake booster does not work or the vehicle is being towed.
- Always keep the footwell beneath the pedals clear so that the brake pedal is unobstructed and can move freely.

Switching the braking support system on and off

Driving situations

In order to avoid risks, the braking assistance systems should not be switched off under normal conditions ⇒ .

WARNING

When ESC is switched off, the risk of the vehicle swerving is significantly higher. The vehicle can be difficult for inexperienced drivers to handle at high speeds. Accidents and serious or fatal injuries could result.

- Switch ESC off only if you are experienced in driving off-road.
- Only switch on ESC Sport if you are driving on a closed track and are experienced in sporty driving.
- Do not take any risks.

Switching on and off

1. Open the vehicle settings of the Infotainment system ⇒ [Vehicle settings menu](#).
2. Open the Vehicle menu.
3. Open the Exterior menu.
4. Open the Brakes menu.
5. Activate the function in the ESC system drop-down list.

If the setting is no longer being used, you should completely switch off the braking assistance system again ⇒ .

ASR

It can be helpful to switch off ASR when the vehicle is driven on loose ground or when “rocking” the vehicle out of place because it is stuck ⇒ .



ASR manually switched off. The yellow indicator light turns on.

ESC Sport

The function assists with sporty driving. The ESC intervenes later to stabilize the vehicle, e.g. during fast cornering ⇒ .



ESC Sport is switched on. The yellow indicator light turns on.

ESC Off

The function assists experienced drivers with offroad driving. The ESC is switched off and stabilizing interventions are not performed. Always read the safety instructions ⇒ .



ESC manually switched off. The yellow indicator light turns on.

1. Depending on the vehicle equipment, confirm the selection in the instrument cluster.

Defining ESC mode as a favorite in the Infotainment system

To access ESC settings directly, you can save a favorite function, e.g. for switching off ESC, in Control Center in the Infotainment system. This function depends on the vehicle equipment → page , *Overview of Infotainment system*.

Troubleshooting

ABS ABS failure or malfunction

The yellow indicator light turns on.

1. Contact a suitably qualified professional. Volkswagen recommends contacting an authorized Volkswagen dealer or authorized Volkswagen Service Facility ⇒ .

The vehicle can be braked without ABS.



ESC malfunction

The yellow indicator light turns on. ESC has been switched off.

There is a fault or malfunction.

1. Switch the ignition off and on.
2. Drive a short distance at a speed of approximately 15 km/h (approximately 9 mph) to 20 km/h (approximately 12 mph).
3. If the  indicator light stays on, contact a suitably qualified professional. Volkswagen recommends contacting an authorized Volkswagen dealer or authorized Volkswagen Service Facility.

Noises in the braking assistance systems

When the braking assistance systems are actively regulating, the brake pedal may move or noises may occur.

1. Continue braking with the necessary force and steer the vehicle as required.

WARNING

If the **BRAKE** brake warning light comes on together with the **ABS** indicator light, the regulating function of the ABS could be malfunctioning. This can cause the rear wheels to lock when braking. This could cause you to lose control of the vehicle and lead to accidents with serious or fatal injuries.

- Drive at low speed to the nearest authorized Volkswagen dealer or authorized Volkswagen Service Facility to have the brake system checked. Volkswagen recommends contacting an authorized Volkswagen dealer or authorized Volkswagen Service Facility.
- Avoid sudden braking or driving maneuvers.

WARNING

If the **ABS** indicator light does not turn off, or comes on during the journey, the ABS is not working correctly. The vehicle can only be stopped with the normal brakes. If the ABS is restricted, this may lead to accidents causing damage to the vehicle and serious or fatal injuries.

- Contact an authorized Volkswagen dealer or authorized Volkswagen Service Facility. Volkswagen recommends contacting an authorized Volkswagen dealer or authorized Volkswagen Service Facility.

Driving on slopes

Hill start assist

Hill start assist helps when starting to drive uphill by actively holding the vehicle in place.

Functional requirements

The following requirements must be met at the same time:

- The vehicle must be stationary and held with the brake pedal until you start driving.
- The engine must be running “evenly”.
- A gear or a position is engaged for driving uphill.

To start driving, take your foot off the brake pedal and press the accelerator pedal immediately. The brakes will release gradually as you start driving.

 The holding function of the Hill Start Assist remains active only for a short time. Drive off within approx. two seconds.

When is it active?

Hill Start Assist will deactivate immediately under the following conditions:

- If the driver leaves the vehicle.
- If the engine is running “unevenly” or in the event of an engine fault.
- The engine is switched off or it stalls.
- The transmission is in the neutral position **N**.
- A downhill gear or position is selected.

CAUTION

If you do not pull away immediately after releasing the brake pedal, the vehicle may roll backward under certain circumstances. This can cause injuries or damage to objects.

- If this is the case, press the brake pedal or set the electronic parking brake immediately.
- Press the brake pedal for a few seconds before you start to drive if you are driving on an incline in heavy traffic and

you would like to prevent the vehicle from rolling backwards when starting to drive.

Hill Descent Control

Hill Descent Control helps the driver when traveling on slopes.

How it works

Hill descent control maintains the speed on all four wheels when driving forward or in reverse on steep inclines through automatic braking interventions. The wheels will not lock up because the Anti-Lock Brake System (ABS) remains active.

When starting to drive downhill at speeds less than approx. 30 km/h (approx. 19 mph), the speed is limited to minimum approx. 2 km/h (approx. 1 mph) and maximum approx. 30 km/h (approx. 19 mph). The driver can increase or decrease the vehicle speed within these speed limits by accelerating or braking.

However, there must be enough traction. If the downhill slope is icy or the surface is greasy, for example, Hill Descent Control cannot function properly.

Displays

Depending on the driving situation, one of the following indicator lights will light up in the instrument cluster:

 Hill Descent Control is active.  Hill Descent Control is not active.

 If hill descent control is not active, the indicator light turns gray. The system is activated, but it is not regulating.

When is it active?

Hill descent assist is automatically activated under the following conditions:

- The vehicle engine must be running.
- The speed must be less than approx. 30 km/h (approx. 19 mph), the  indicator light appears in the instrument cluster display.
- The gradient must be at least 10%.
- The brake pedal or accelerator pedal must not be pressed.

Hill Descent Control is deactivated if the speed is higher than approx. 30 km/h (approx. 19 mph), when the brake pedal or accelerator pedal is pressed, or the gradient is less than 5%.

WARNING

Hill Descent Control is not a replacement for the driver's attention and works only within the system limitations. Hill Descent Control cannot detect all driving situations and may not react, or may react with a delay, or may react in a way that is not desired. If you are careless, there is a risk of accidents due to unintentional vehicle movement. This can cause serious or fatal injuries.

- Always stay attentive and do not rely solely on the system. The driver is always responsible for control of the vehicle.
- Be aware that Hill Descent Control cannot hold the vehicle on the incline or brake sufficiently going downhill in every situation, for example if the ground is slippery or icy.
- Always be ready to brake, in particular if the ground is slippery or icy.
- Manually brake the vehicle if the vehicle moves faster despite Hill Descent Control.
- Always adapt your speed and driving style to the visibility, weather, road and traffic conditions.

4MOTION Active Control

Introduction

Via the driving modes, the driver can adapt various properties of vehicle systems to the current driving situation, the desired driving comfort, and for an economic driving style. The suspension, steering, drive, and the air conditioner are some of the vehicle systems that can be adjusted.

Different driving modes are available depending on the vehicle equipment. The influence of vehicle systems on the individual driving modes depends on the vehicle equipment.

Differentiation according to the type of drive

Only vehicles with all-wheel drive can be equipped with 4MOTION Active Control.



Selecting the driving mode

The driving mode can be selected when the ignition is switched on and the vehicle is stationary or while driving.

If you select a driving mode while driving, the vehicle systems, except for Drive, will be switched over to the new driving mode immediately.

1. When the traffic situation allows it, briefly take your foot off the accelerator pedal to enable the newly selected driving mode to be applied to the Drive vehicle system as well.



Selecting the driving mode via the control in the upper center console

1. Tap .
2. To select driving modes, tap  again or tap the desired driving mode in the Infotainment system.

Displaying information about the driving mode

1. To display additional information about the selected driving mode, tap  in the Infotainment system.

Selecting the Custom driving mode







1. Tap  until the Custom driving mode has been selected.
2. Tap  to open the Individual menu.

WARNING

Adjusting driving modes while driving can distract from traffic. This can cause accidents and serious or fatal injuries.

- Always drive attentively and responsibly.

Driving mode properties

 Under Onroad, you can select from the Eco, Comfort, Sport and Custom driving modes.  The Eco driving mode switches the vehicle to fuel-efficient operation and supports the driver with an fuel-saving driving style.  The Comfort driving mode shows the basic settings of the vehicle systems and offers a balanced calibration, for example for everyday use.  The Sport driving mode gives the driver a sporty feel. If the Sport driving mode is selected, vehicles with an automatic transmission switch to **S**.  With the Custom driving mode, you can adapt individual vehicle systems according to your preferences.  With the Offroad driving mode, you can better control acceleration with the accelerator pedal when driving off-road. The engine's braking efficiency is always available and shifting can be blocked in critical situations. The hill

start assist and hill descent control are active in the Offroad driving mode. The dynamic cornering light is adjusted to better assist the driver when visibility is poor. ❄️ Using the Snow driving mode can improve the traction on slippery or snowy ground by having a more precise power transmission.

! NOTICE

Using an offroad driving mode may result in increased fuel consumption and tire wear as well as increased noise levels during normal driving.

- Avoid using offroad driving modes in normal road conditions.

Standard behavior of the driving mode and the vehicle systems

The Comfort driving mode shows the basic settings of the vehicle systems when the ignition is switched on.

Behavior of the driving mode when switching the ignition off and on

If you switch the ignition off and then on again, the previously selected driving mode remains selected.

If you had previously selected the Snow or Offroad driving mode and switched the ignition off and then back on, the last selected onroad driving mode will be set.

Behavior of the Drive vehicle system when the ignition is switched off and on

The Drive vehicle system settings are reset to the Comfort driving mode settings when you switch the ignition off and on again. The other vehicle systems will retain their settings.

You can change the Drive vehicle system back to the preferred driving mode.

1. Select your desired driving mode again.

Or: In order to reactivate the settings in the Sport driving mode, move the automatic transmission selector lever backwards into driving mode **S**.

Troubleshooting

⚡ gear cannot be engaged

In the driving modes Offroad and Snow, it is not possible to switch to the ⚡ gear. Information is shown in the instrument cluster display if an Offroad driving mode has been selected.

1. A different driving mode must be selected in order to switch to the ⚡ gear.

The driving mode or the vehicle systems do not behave as expected

1. Pay attention to the standard behavior of the driving mode and the vehicle systems → [Standard behavior of the driving mode and the vehicle systems](#).

Off-road driving situations

📖 Introduction

The examples described in this chapter are to be understood as general guidelines aimed to help the driver in driving safely on off-road terrain. These tips will not necessarily apply to every possible situation that may occur. Before driving on unknown terrain, it is crucial to find out information about the condition of the terrain ahead. You can assess potential dangers in advance. The driver is responsible for deciding whether their vehicle is suitable for the terrain ahead and if the terrain can be driven on.

Driving off-road requires different skills and handling practices compared to driving on developed roads.



This vehicle is not designed for traveling with an “expedition driving style”.

With 4MOTION Active Control in a four-wheel drive vehicle, various vehicle tuning adjustment can be selected to the driver's preference ⇒ *Selecting the driving mode*.

Switch off the driver assistance systems and parking systems when off-roading.



Checklist

The following steps should be taken before the first trip to operate and drive the vehicle safely off-road.

- ✓ Observe the general safety precautions when driving off-road ⇒ *Safety precautions for driving off-road*.
 - ✓ Fold up or remove the ball mount.
 - ✓ Adjust the seating position so there is clear visibility in front of the vehicle and fasten safety belts ⇒ *Seating position*.
 - ✓ Always wear suitable and well-fitted footwear that gives the feet good traction on the pedals.
-  A responsible driver also treats nature with care when driving off-road. Driving over shrubs and meadows can destroy the habitats of animals and plants.
-  Leaking operating fluids resulting from vehicle damage can contaminate the environment. Catch any leaking operating fluids and dispose of them correctly according to environmental regulations.

 Take any suitable equipment with you for driving off-road.

Safety precautions for driving off-road

 Refer to ⇒  and .

WARNING

ABS and ESC cannot replace the driver's attention, can only operate within the limitations of the system and were developed only for driving on developed roads. ABS and ESC are not suitable for use off-road. If you are careless, there is a risk of accidents, serious injuries and death.

- Always stay attentive and do not rely solely on the systems. The driver is always responsible for control of the vehicle.
- Always adapt the speed and driving style to the predominant terrain. Unfavorable ground conditions can lead to vehicle instability even with ABS and an activated ESC, e.g. under hard braking or in corners.

WARNING

Driving off-road can be difficult and dangerous and lead to critical driving situations for vehicle occupants. It can lead to loss of control over the vehicle, damage to the vehicle, failure of the vehicle far away from any assistance, accidents and serious or fatal injuries.

- Never choose a dangerous route and do not take risks.
- Turn around and choose a different route if you can go no further or you have doubts about the safety of the route.
- Explore the terrain on foot beforehand even if it looks easy to negotiate.
- Drive with extreme caution and anticipation when driving off-road.
- Never drive faster than is appropriate for the predominant terrain, road conditions, traffic and weather.

WARNING

Driving over embankments, ramps or hillsides at excessively high speeds can cause the vehicle to lose contact with the ground. The vehicle can roll over if the wheels are turned inward when coming back into contact with the ground. This could cause you to lose control of the vehicle and lead to accidents with serious or fatal injuries.

- Do not drive off-road at excessive speeds.
- If the vehicle does lift off the ground, always align the front wheels so they face straight ahead.

WARNING

Sporty multi-purpose vehicles have a higher center of gravity and therefore a greater risk of rolling over while driving than a regular passenger vehicle that is not suited for off-road driving ⇒ *Explanations of technical terms*. This can cause accidents and serious or fatal injuries.

Utility vehicles have a significantly higher rollover rate than other types of vehicles.

- In a rollover crash, an unbelted person is significantly more likely to die than a person wearing a seat belt.
- Never drive too fast, especially through corners.
- Do not attempt extreme driving maneuvers.
- Always adapt the speed and driving style to the predominant terrain.

WARNING

Luggage and other objects transported on the roof of the vehicle also increases the center of gravity and thus the risk of a rollover accident. This can cause accidents and serious or fatal injuries.

- Store luggage and other items in the luggage compartment where possible. Store heavy luggage and items as low down as possible.

WARNING

Sections of terrain that seem safe could be very dangerous and put vehicle occupants in danger. Potholes, depressions, ditches, hollows, obstacles, shallow areas, and soft and swampy ground are often not detected as such and can be completely or partially covered by snow, water, grass, or branches on the ground. Driving over such sections of terrain can cause failure of the vehicle, accidents and serious or fatal injuries.

- Before driving on unknown terrain, explore the route carefully on foot.
- Never choose unsafe routes and do not take risks.
- Turn around and choose a different route if you have doubts about the safety of the route.
- Always adapt the speed and driving style to the load, visibility, terrain and weather conditions.

WARNING

Driving at an angle on a hill can be dangerous. The combined center of gravity of the vehicle and its load (passengers and cargo) can cause it to shift and cause the vehicle to tip over and roll down the hill. This can cause vehicle damage, accidents and serious or fatal injuries.

- Always avoid driving at an angle on a hill ⇒ *Driving at an angle on a hill*.
- If it is necessary, always exit the vehicle carefully using the doors on the side of the vehicle that is facing uphill

⇒ *Driving at an angle on a hill.*

- If the vehicle stops at a side angle on a hill, never exit the vehicle through the doors that are facing in the downhill direction.

WARNING

The driver assistance systems were developed only for driving on developed roads. The driver assistance systems are not suitable for use off-road and can thus be dangerous in off-road situations. This could cause you to lose control of the vehicle and lead to accidents with serious or fatal injuries.

- Never use driver assistance systems off-road.

WARNING

Driving with an insufficient fuel level can lead to a vehicle breakdown off-road. The steering and braking support systems will not work if the engine is “sputtering” or malfunctioning due to fuel shortage or irregular fuel supply. This can cause accidents and serious or fatal injuries.

- Always refuel your vehicle with enough fuel before driving off-road.

NOTICE

If the windows and sunroof are open, rain could enter the vehicle and soak the interior, causing vehicle damage.

- Always keep the windows and power sunroof closed when driving off-road.

Explanations of technical terms

 Refer to ⇒  and  *Safety precautions for driving off-road.*

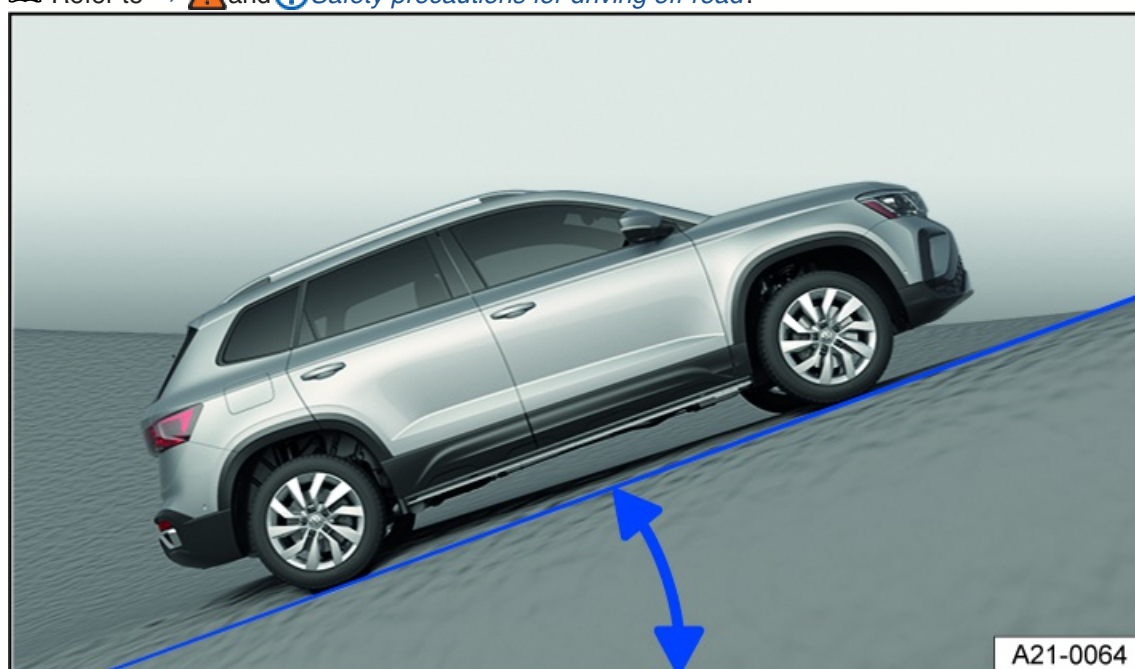

Fig. 96 General example: incline angle

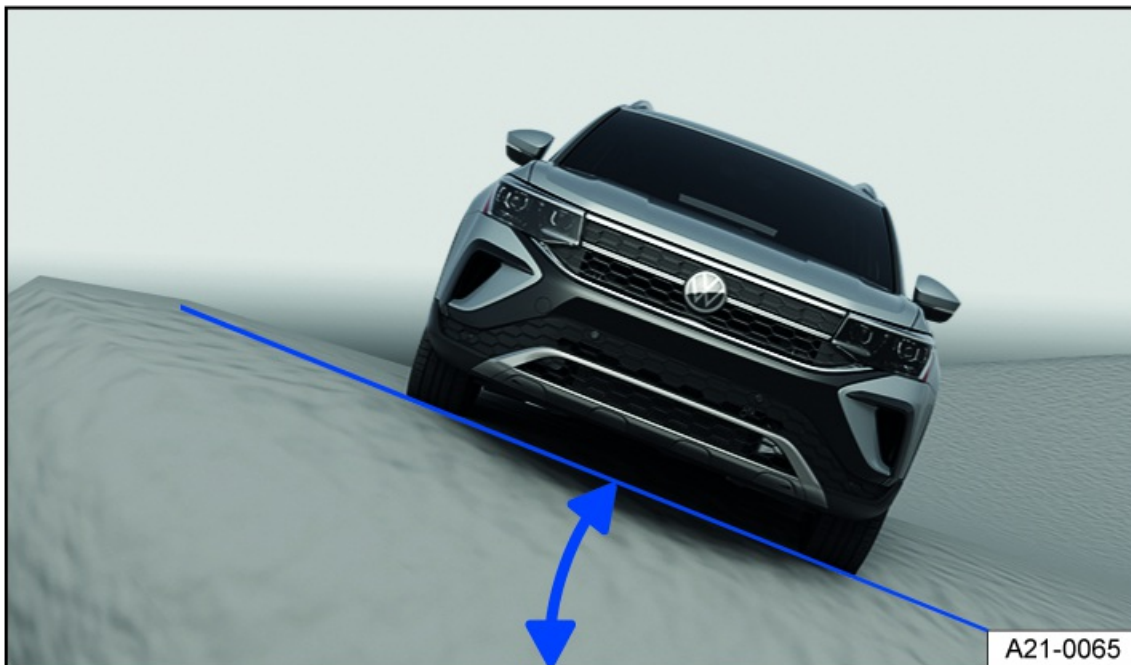

Fig. 97 General example: tilt angle

Center of gravity The center of gravity of a vehicle influences the risk of rollover accidents. When driving off-road, the vehicle has a larger ground clearance and thus a higher center of gravity compared to “normal” road vehicles. Due to the higher center of gravity, there is an increased risk that the vehicle could roll over while driving. Always consider this fact while driving and always observe the safety tips and warnings listed in this Owner's Manual.

Ground clearance The distance between the road surface and the lowest point of the vehicle underbody.

Incline angle The maximum angle the vehicle can drive up an incline on its own. A rising difference in altitude (incline) on a 100 m (approx. 330 ft) stretch is given in percentage or degrees *fig. 96*. The maximum incline angle the vehicle can handle depends on the road surface and the engine power, among other things.

Tilt angle The maximum angle that the vehicle can drive diagonally or perpendicularly to the fall line on a hill without tipping over (depends on the center of gravity) *fig. 97*.

Ramp angle Maximum angle that the vehicle can drive over a ramp at slow speeds without the vehicle underbody coming into contact with the edge of the ramp.

Slope angle The transition from the horizontal plane on an incline or from the slope back to level ground. Maximum angle that the vehicle can handle without the vehicle underbody coming into contact with the edge of the slope.

Fall line The line that is the most direct path downhill.

Axle articulation The torsional flexibility of a vehicle when driving over an object on one side.

Checklist “before driving off-road”

Refer to ⇒  and  *Safety precautions for driving off-road*.

Checklist

For your safety and the safety of your passengers, always observe the following points before driving off-road:

- ✓ Learn about the quality of the upcoming terrain before driving off-road.
- ✓ Fill up the fuel tank. Fuel consumption is significantly higher off-road than it is on developed roads.
- ✓ Check if the tire profile and the type of all the tires is sufficient for the planned off-road trip.
- ✓ Check and adjust the tire pressure on all tires.
- ✓ Check the engine oil level and add engine oil if necessary. When the vehicle is on sloping ground, the engine will only

supplied with engine oil if the engine oil level is sufficient.

- ✓ Fill the windshield washer fluid reservoir completely with water and windshield washer fluid.
- ✓ Stow any luggage as low as possible in the vehicle and distributed evenly. Secure all loose objects safely.

General rules and driving instructions

Refer to ⇒  and  *Safety precautions for driving off-road*.

- Volkswagen recommends to never drive off-road alone. At least two off-roading vehicles should drive together off-road. An unexpected situation could occur at any time. Therefore, it is especially wise to have equipment that can be used to call for emergency assistance.
- Stop and explore the path on foot, especially before critical passages.
- Drive over bumps slowly so that the vehicle does not lift up, which could cause damage and prevent you from maneuvering the vehicle.
- Drive slowly through difficult sections of the route. Upshift on slippery ground and always keep the vehicle in motion.
- There is usually a lot of soft ground on off-road terrain, where the tires could sink into the ground. This reduces the ground clearance and the wading depth. Whenever possible, drive on level and solid ground.
- Even at low speeds, always maintain a safe distance to other vehicles. If the first vehicle suddenly becomes stuck, the vehicle following it would be able to stop in time without also getting stuck.

NOTICE

Severe damage to the underbody can occur if the vehicle hits the ground. This damage can cause vehicle breakdowns and make it impossible to continue driving.

- Always make sure there is enough ground clearance under the vehicle.

Shifting gears correctly

Refer to ⇒  and  *Safety precautions for driving off-road*.

Correct gear selection depends on the terrain.

Before driving on a difficult stretch of the route, it may be helpful to stop and consider which gear to select. After several off-roading trips, you can learn which gear in conjunction with gear reduction is best suited for certain areas of terrain.

- When the correct gear is selected, the vehicle must normally be braked less with the brake pedal because the engine braking effect will be sufficient in the majority of cases.
- Only accelerate as much as necessary. Too much acceleration can cause the wheels to spin and thus loss of control of the vehicle.
- Use the **D** selector lever position on normal, level stretches of off-road land.
- Adjust your speed when driving on soft or slippery ground and drive at the highest possible gear in tiptronic mode.
- Drive using tiptronic in gear **1** when on steep hills or on a steep incline.
- Drive using tiptronic in gears **3** or **2** when on mud, sand, water, or hilly areas ⇒ *Selector lever*.

Driving over brush and rock

Refer to ⇒  and  *Safety precautions for driving off-road*.

1. Select a suitable driving mode ⇒ *Selecting the driving mode* and drive no faster than walking speeds over rocky ground.
2. If you are unable to drive around a stone, drive carefully onto the stone with one of the front wheels and then drive slowly over it ⇒ .

Even objects that are lower than the available ground clearance can come into contact with the vehicle underbody and cause vehicle damage and malfunctions. This is especially true if there is a depression or soft ground in front of or behind the object. This is also true if the vehicle drives too fast over an object and then the suspension compresses.

! NOTICE

If driven over, objects that are higher than the ground clearance will damage vehicle components on the underbody. This damage can cause vehicle breakdowns and make it impossible to continue driving.

- Never drive over a very large object such as boulders or tree trunks if it is under the vehicle or on one side.

Driving through still or flowing water

Refer to ⇒  and  *Safety precautions for driving off-road*.

Driving through flooded terrain or bodies of water could cause vehicle damage.

You can carefully drive through water that comes up to the lower edge of the vehicle body.

1. Note the maximum wading depth of the vehicle.
2. Only drive through water in an area where the ground is solid underneath it remains lower than the maximum permissible wading depth.
3. Note the additional information for driving through water on paved roads ⇒ *Driving through water on roads*.

Before driving through water

Stop, get out and assess the situation ⇒ :

1. Measure the depth of the water all the way over to the other side. Make sure that the ground is firm enough and identify any dips and obstacles ⇒ .
2. Make sure that it is possible to safely enter and exit the water.
3. Check the ramp angle and firmness of the banks.
4. Select a suitable driving mode ⇒ *Selecting the driving mode*.

Driving through still or slow-flowing water

As long as the ground is firm enough, you can drive your vehicle through still or slow-flowing water ⇒ .

1. Drive into the water slowly and in the direction of the current. Never exceed the ramp or tilt angle.
2. Drive at a constant speed all the way to the opposite bank.

Driving at a constant speed prevents engine damage caused by the ingress of water. It also allows an air pocket to form in front of the engine, which fuels the engine with the oxygen it requires. If you drive into the water too fast or drive through the water too fast, you will create a bow wave in front of the vehicle. Water from this bow wave may find its way into the engine's intake port and seriously damage the engine.

Driving through fast-flowing water

The strength and speed of the current and the depth of the water can be dangerous and unpredictable ⇒ . Vehicles can be swept away by the current. Even vehicles with generous ground clearance can get stuck if the ground beneath their tires is swept away. Flowing water backs up against one side of the vehicle, making the water deeper on that side.

Do not take any risks. Look for a shallower place to cross the water or turn back.

After driving through water

1. Check the vehicle for damage.

2. Gently apply your brakes to dry them off.

WARNING

Flowing water generates enormous power and can carry a vehicle away. This can cause accidents and serious or fatal injuries.

- Never let the vehicle stop in water.

WARNING

Soft ground, obstacles under the water, shallows, or water in the hood space can lead to critical driving situations and vehicle failure. This can cause accidents and serious or fatal injuries.

- Do not exceed the wading depth of your vehicle.
- Always make sure there is enough ground clearance under the vehicle.

NOTICE

If you drive through salty water, vehicle components such as the engine, drivetrain, suspension, or vehicle electrical system could become severely damaged.



- Never drive over salt, salty surfaces, or through salt water, because salt can cause corrosion.
- Using fresh water, immediately rinse down any parts of the vehicle that may have come into contact with salt or salty water.

NOTICE

Objects in the water can enter the openings of the extended spray nozzles of the headlight washer system. The spray nozzles then cannot move back to their basic position.

- Do not use the headlight washer system when you are driving through water.

Driving in sand and mud

 Refer to  and  *Safety precautions for driving off-road*.
ESC and ASR must be switched on \Rightarrow *Braking assistance systems*.

1. Select a suitable driving mode \Rightarrow *Selecting the driving mode*.
2. Select a suitable gear and stay in that gear until solid ground is reached \Rightarrow *Shifting gears correctly*.
3. Always drive through sand or mud at a constant speed, do not perform manual shifts and do not stop.

The tires can lose their grip in sand or mud.

- Do not change the speed or direction.
- If the vehicle slides, steer in the direction in which it is sliding to regain control of the vehicle.
- If the tires are no longer gripping the ground, turn the steering wheel back and forth quickly. This can briefly create better tire traction between the ground at the front wheels.

WARNING

The vehicle could slide out of control if driven through sand and mud. This can cause accidents and serious or fatal injuries.

- Always drive carefully when you have to drive through sand, mud, or slush.
- Turn around or choose a different route if you can go no further or you have doubts about the safety of the current route.
- Never select a dangerous route or undertake a risk that would endanger other vehicle occupants.

WARNING

Incorrect tire pressures cause increased tire wear and impair vehicle handling. This can cause overheating, sudden tire damage including tire blow-outs, and stripping of the tread, which can then result in loss of vehicle control. This can cause accidents and serious or fatal injuries.

- If you reduce the tire pressures to drive through sand, inflate the tires back to the correct pressure afterwards.

Recommendations if the vehicle is stuck

 Refer to  and  *Safety precautions for driving off-road*.

The vehicle becomes stuck when the wheels have sunk so deeply into the ground that the vehicle can no longer move forward or backward under its own power.

To rock the vehicle out of sand or mud, training and a lot of strength are necessary. If one makes a mistake when rocking a vehicle out of place, the vehicle can sink even farther and additional assistance will be needed to continue.

Never let the wheels spin for a long time, because this will only make the vehicle sink deeper into the ground .

Preparations

1. Carefully dig out all of the wheels and make sure no other vehicle components are stuck in sand or mud.
2. Select the reverse gear.
3. Accelerate gently and reverse in the same track.

If this does not help, place brushwood, floor mats, or burlap cloth directly behind the tires to create traction to help the vehicle to move .

Rocking the vehicle out of place

1. Switch off ASR  *Braking assistance systems*.
2. Adjust the steering wheel so that it is straight.
3. Drive in reverse until the wheels begin to spin straight.
4. Engage the first gear immediately and begin to drive forward until the wheels begin to spin again.
5. Drive back and forth in this way until there is enough momentum to release the vehicle.
6. Reactivate ASR after the vehicle is rocked out of place.

WARNING

Spinning wheels can greatly accelerate stones, brushwood, pieces of wood, or other objects under the wheels. Persons in front or to the rear of the vehicle could be injured. In the event of sudden vehicle movement, persons in front or to the rear of the vehicle could be injured or run over. This can cause serious or fatal injuries.

- Make sure that no one is present in front or to the rear of the vehicle when attempting to move a stuck vehicle out of place.

Driving on steep terrain

Refer to ⇒  and  *Safety precautions for driving off-road*.

Driving on inclines or slopes

Before driving up an incline or down a hill, stop, exit the vehicle, and assess the situation:

- Go along the path and check the ground for sufficient firmness, obstacles, or other hidden hazards ⇒ .
- Look to see how the path continues after the incline.
- If the route is too steep, too uneven, or the ground is too loose, then do not drive on this path and choose another route.
- Drive uphill or downhill slowly and continuously on a straight path.
- Never stop or turn around on a hillside.
- Only accelerate enough to overcome the incline. Too much acceleration can cause the wheels to spin and the driver to lose control of the vehicle. Too little acceleration increases the likelihood of the engine stalling.
- Vehicles with an automatic transmission Do not shift gears while driving on an incline.

If the vehicle can no longer drive up an incline

- Never turn around on an incline.
- If the engine has stopped, press the brake pedal and restart the engine.
- Select reverse gear and drive slowly and carefully along the same path.
- Maintain a consistent speed using the brake pedal until you reach safe and level ground.

Driving downhill

There is increased risk of rollover accidents when driving downhill. Concentrate very carefully on steering the vehicle when driving downhill.

- Drive in first gear when driving down steep hills.
- Use the brake pedal gently to reduce the risk of losing control of the vehicle.
- Never exceed the tilt angle of the vehicle.
- If it is possible and not dangerous, drive straight downhill along the fall line (maximum slope).

WARNING

If you drive on an uphill or downhill gradient that is too steep for the vehicle, the vehicle could slip, slide away or roll over. This could cause loss of vehicle control, accidents and serious or fatal injuries.

- Ensure that the incline angle or tilt angle is not larger than the maximum permissible value for the vehicle.
- When driving uphill or downhill, always follow the fall line.
- Never change direction or turn round when driving uphill or downhill. The vehicle could tip over or slide.
- If the engine stalls or if your vehicle can go no further, carry out the tasks described → page , *If the vehicle can no longer drive up an incline*.
- If the engine will not start, press the brake pedal down, applying constant pressure, and allow the vehicle to roll back the same way you came. Keep to a steady, low speed.
- Never allow the vehicle to coast backward down the incline.

Driving at an angle on a hill

Refer to ⇒ ⚠ and ⚠ Safety precautions for driving off-road.



Fig. 98 General example: steering downhill along the fall line.

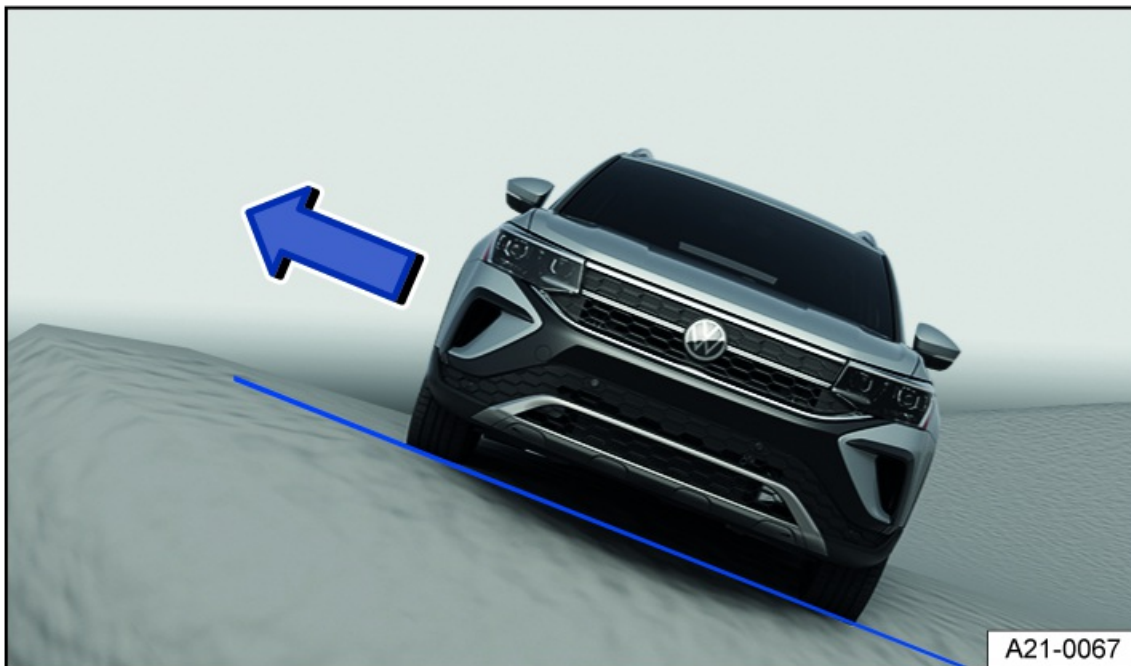

Fig. 99 General example: exit through the side of the vehicle that is facing uphill.

Driving at an angle on a hill is dangerous when driving off-road ⇒ ⚠.

Before driving, always check if there are other safer routes available.

If you must drive at an angled position:

- The vehicle's center of gravity should be as low as possible. Larger or heavier individuals should sit on the more elevated side of the vehicle. Luggage on the roof should be removed and heavy objects should be secured, because the vehicle could tip over due to objects suddenly sliding out of place ⇒ ⚠.
- The ground must be as firm as possible. The vehicle can skid sideways and tip over more easily on slippery or soft ground. Always make sure the angle will not become too large from bumps in the road. The vehicle can tip and roll over when the tilt angle is too large.
- If the vehicle is positioned at a high angle, the wheels on the lower side of the vehicle must never drive over depressions

or dips in the ground. The wheels on the higher side of the vehicle must never drive over elevated objects, such as stones, tree trunks, or other obstacles.

- If it seems the vehicle is about to tip, immediately steer toward the downhill direction and accelerate lightly *fig. 98*. If it is not possible to steer downhill, steer uphill and accelerate lightly.

WARNING

A vehicle that is driven or positioned sideways to the incline of a hill can slip out of control, roll over and roll down the hill. This can cause accidents and serious or fatal injuries.

- Never attempt to drive at an angle on a hill, especially if the hill is too steep for the vehicle.
- Never select a dangerous route or undertake a risk that would endanger the vehicle occupants.
- Turn around and choose a different route if you can go no further or you have doubts about the safety of the route.
- Never underestimate the risks and dangers of driving at an angle on a hill.
- Never let the wheels on the lower side of the vehicle drive through depressions or dips in the ground.
- Never let the wheels on the higher side of the vehicle drive over elevated objects, such as stones, tree trunks, or other obstacles.
- Before driving at an angle on a hill, make sure that you can steer toward the fall line. If that is not possible, choose another path.
- If it seems the vehicle is about to tip, immediately steer toward the downhill direction and accelerate lightly *fig. 98*.



WARNING

It is dangerous to exit the vehicle positioned with a substantial sideways tilt on a hill. The overall center of gravity could shift to the side and the vehicle can lose hold, tip or flip over and roll down the hill. This can cause accidents and serious or fatal injuries.

- Avoid abrupt and uncontrolled movements in the vehicle.
- If it is necessary, always exit the vehicle carefully using the doors on the side of the vehicle that is facing uphill *fig. 99*.
- Never leave the vehicle through a door on the downhill side.
- When exiting the vehicle, ensure that the upwards opening door does not shut and cause injury due to its own weight or passenger inattention.

Driving through ditches

 Refer to  and  *Safety precautions for driving off-road*.

1. Check if the slope and tilt angle is small enough to drive over the ditch with the vehicle. The tilt angle must not be too large when driving through the ditch .
2. Find a suitable point to drive through the ditch.
3. If possible, cross the ditch at a sharp angle .

WARNING

If the slope and tilt angle is too steep for the vehicle and the ditch is too deep, the vehicle could tip, slide away and roll over. This can cause accidents and serious or fatal injuries.

- Do not attempt to drive across a ditch if the ramp angle or tilt angle is too steep and the ditch is too deep for the

vehicle.

! NOTICE

If driving into the ditch at a right angle, the front wheels will fall in. The vehicle could bottom out, be damaged, and no longer be drivable.

- Do not attempt to drive across a ditch if the ramp angle or tilt angle is too steep and the ditch is too deep for the vehicle.
- Note that it will most likely be impossible to drive out of the ditch, even with all-wheel drive.

After off-road driving

📖 Refer to ⇒  and  *Safety precautions for driving off-road.*

Checklist

- ✓ Clean the vehicle.
- ✓ Check the vehicle for damage.
- ✓ Check the tires for damage and remove any thick dirt, stones, and foreign objects from the tread.
- ✓ Inspect the vehicle underbody and remove any and all objects that are stuck in the brake system, wheels, suspensions exhaust system and in the engine, such as twigs, leaves, or pieces of wood ⇒ . If any damage or leaks are discovered, seek assistance from suitably qualified professionals. Volkswagen recommends contacting an authorized Volkswagen dealer or authorized Volkswagen Service Facility.
- ✓ Inspect the hood space for any contamination that may be impairing engine operation ⇒ *Safety precautions for working in the hood space.*

WARNING

Any objects stuck under the vehicle underbody present a hazard. Fuel lines, the brake system, seals and other suspension parts can be damaged or flammable materials, such as dry leaves, can ignite near hot vehicle components. This could cause an accident, a fire and serious or fatal injuries.

- Always inspect the vehicle underbody for stuck objects and remove them after every off-road trip.
- Never drive the vehicle if objects are stuck on the underbody, in the brake system, in the wheels, in the suspension, in the exhaust system, or in the engine.
- Remove flammable materials, such as dry leaves, from the vehicle underbody.

Messages about driving

General driver information

Anticipatory driving

An inconsistent driving style increases consumption. When the driver actively pays attention to traffic, this can prevent frequent acceleration and braking maneuvers. Maintaining enough distance to the vehicle driving ahead helps you to drive with better anticipation.

Avoiding Harsh Acceleration

Excessively high speeds increase the rolling resistance and air resistance and with that, the power needed to move the

vehicle. Never drive at the maximum vehicle speed.

Checking tire pressures

Low tire pressures cause wear as well as increased rolling resistance of tires, and this increases consumption. Use tires with optimal rolling resistance.

Adapt the tire pressures to the load:

- Follow the specifications on the tire pressure label ⇒ *Checking the tire pressure*.
- Tire pressure monitoring system ⇒ *Function of the Tire Pressure Monitoring System*.

Warming up the engine

Driving short distances too frequently may cause foreign matter such as condensation to collect in the engine oil and cause increased engine wear.

If the driving behavior leads to an increased collection of foreign matter in the engine oil, a corresponding message appears in the instrument cluster display. If you are warming up the engine, wait until the operating temperature is reached and the message disappears.

 At low outside temperatures, it may take longer until the engine has warmed up and the operating temperature is reached. This is normal and not a cause for concern.

Using synthetic engine oil

Full synthetic engine oils with a low viscosity reduce the frictional resistance in the engine and distribute significantly better and faster when cold-starting the engine.

WARNING

Not paying attention to road traffic can cause accidents and serious or fatal injuries.

- Always comply with the applicable driving regulations and speed limits and think ahead while driving.
- Take regular breaks on long drives. You should take a break at least every two hours.

WARNING

Alcohol, drugs, medication, and prescription narcotics can considerably impair perception, reaction times, and driving safety, which can result in loss of vehicle control. This can cause accidents and serious or fatal injuries.

- Do not drive under the influence of alcohol, drugs, medication or prescription narcotics.

WARNING

If you drive at high speed and without sufficient safety distance, accidents and serious or fatal injuries can result.

- Always adapt your speed and remain a safe distance to vehicles driving ahead according to the visual, weather, road, and traffic conditions.

Breaking in the engine

A new engine needs to be broken in during the first approx. 1500 km (approx. 1000 miles). All moving parts should be able to work together. During

the first few hours of operation, the engine has a higher internal friction than it will later.

Up to approx. 1000 km (approx. 600 miles)

- Avoid harsh acceleration.
- Do not use more than two thirds of the maximum engine RPM.
- Do not drive with a trailer.

Between approx. 1000 and 1500 km (approx. 600 and 1000 miles)

1. Increase the speed and engine RPM gradually.

The driving style during the first approx. 1500 km (approx. 1000 miles) also affects the engine's quality. To reduce engine wear and increase the possible mileage, the engine should be driven at moderate engine speeds even after that – especially when the engine is cold.

 New tires and brake pads must be carefully broken in.

NOTICE

Driving at too low an RPM can cause increased wear and damage to the engine.

- Do not drive at an insufficient engine speed.
- Downshift if the engine stops running “smoothly”.

 If the new engine is broken in gently, its service life is increased while, at the same time, reducing engine oil consumption

Eco tips

The correct driving style can help to reduce consumption, pollution, and wear on the engine, brakes, and tires. The following tips will help you conserve the environment and your money.

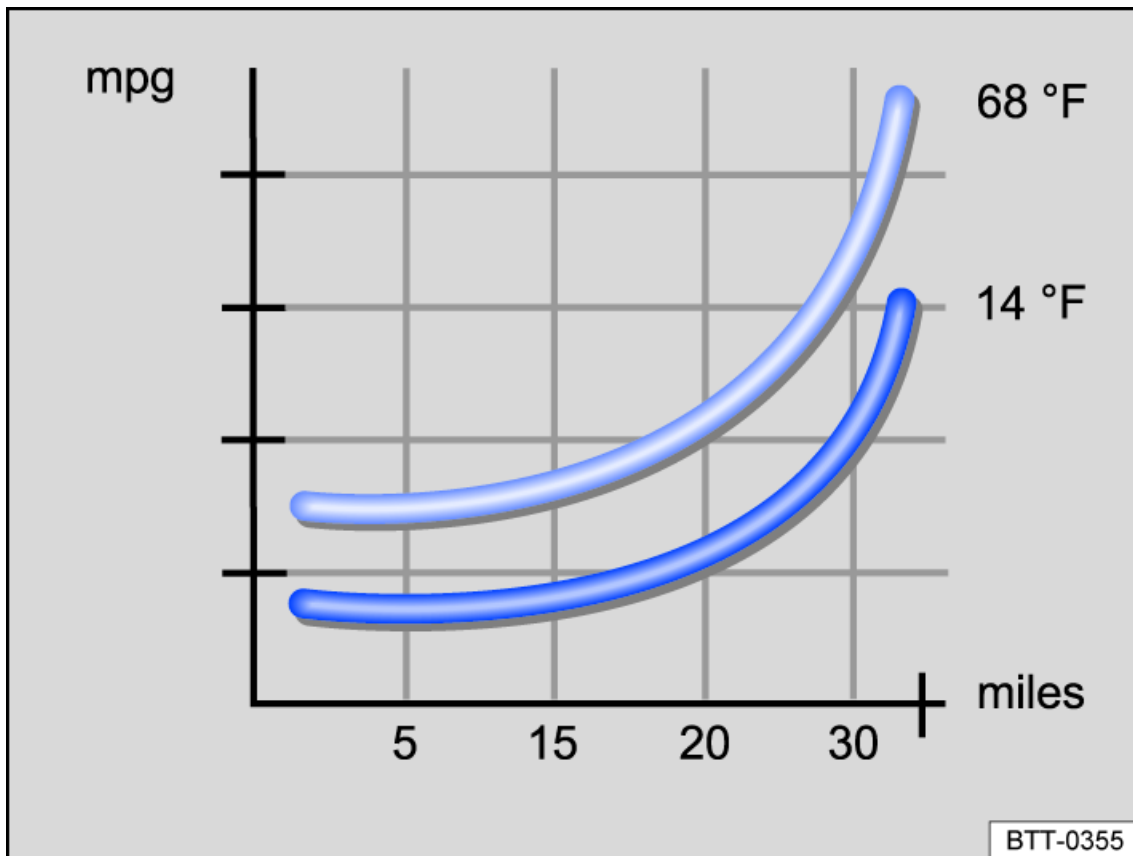

Fig. 100 Fuel consumption in mpg at two different ambient temperatures.

Energy-Saving Shifting

Early upshifting at an engine speed of approx. 2000 rpm saves energy. Do not wait as long as possible to upshift gears and avoid high engine speeds.

- Vehicles with an automatic transmission: Accelerate slowly and avoid using the kick-down function.
- If possible, use the **ECO** driving mode.

Reducing to idle speed

Start driving immediately at low speeds. When stationary for a long time, do not shift to idle, but rather stop the engine, for example when in a traffic jam or at a railroad crossing.

On vehicles with an activated start-stop system, the engine can turn off automatically when the vehicle is stopped and when stationary.

Refuel in moderation

A full fuel tank increases the vehicle weight. A fuel tank that is half to three-quarters full is best suited for city driving.

Avoid short trips

A cold engine has a very high consumption rate. The optimal operating temperature is only reached after several kilometers (miles). When outside temperatures are very low, for example in winter, the consumption is much higher than average [fig. 100](#). Plan trips economically and combine short trips.

Have maintenance performed regularly

Regular maintenance is required for fuel-efficient driving and increases the service life of the vehicle.

Removing unnecessary weight

Clearing out the luggage compartment, for example by removing empty crates or unneeded child restraints, can reduce consumption.

To keep the vehicle's air resistance as low as possible, remove attachments after use.

Saving energy

The alternator, which is powered by the engine, generates power for the electrical equipment, such as the air conditioner, window heating, or ventilation. Saving energy is simple, for example:

- When temperatures are high, air out the vehicle before driving and drive short distances with the windows open. Then turn on the climate control system.
- Switch off comfort consumers that are not required.

NOTICE

If the vehicle rolls down mountains or hills in neutral **N**, the transmission is not lubricated. This can cause the automatic transmission to overheat and can damage it.

- Never leave the vehicle in neutral **N** gear, especially when the engine is stopped.

 An authorized Volkswagen dealer or authorized Volkswagen Service Facility can provide you with more information about correct maintenance and replacement parts that are particularly energy efficient, such as new tires.

 In driving situations when less power is required, the engine cylinders can deactivate automatically on vehicles with Active Cylinder Management (ACT), depending on the vehicle equipment. When the engine is switched off, no fuel is injected into the relevant cylinders, meaning that overall fuel consumption is reduced.

Driving a loaded vehicle

Heed the following for good vehicle handling when the vehicle is loaded:

- Stow all cargo securely ⇒ *Transporting*.
- Accelerate with extra care and caution.
- Avoid sudden braking and driving maneuvers.
- Brake earlier than usual.
- If necessary, read and heed the information about roof racks ⇒ *Roof rack*.
- If necessary, note the information about driving with a trailer ⇒ *Trailer towing*.

WARNING

Sliding loads can considerably impair the driving stability and safety of your vehicle, and increase the braking distance when you brake hard or perform emergency braking. This can cause accidents and serious or fatal injuries.

- Correctly secure the load to prevent it from sliding.
- Use suitable tie-downs or securing straps on heavy objects.
- Engage the rear seat backrests and, if necessary, the adjustable rear seats securely.

Driving with an open trunk lid

Driving with an open trunk lid can be especially dangerous. Secure all objects and the open trunk lid correctly.

Sufficient precautions must be taken to reduce the amount of poisonous exhaust that enters the vehicle.

WARNING

If driving with the trunk lid unlocked or open, loose objects can fall out of the vehicle and injure other road users. This can cause accidents and serious or fatal injuries.

- Always drive with the trunk lid closed.
- Store all objects in the luggage compartment securely.
- Always drive carefully and anticipate upcoming traffic situations.
- Avoid abrupt or sudden driving and braking maneuvers because the open trunk lid can move in an uncontrolled manner.
- If there is a roof rack with cargo on the trunk lid, always remove it before driving with an open trunk lid.

WARNING

Objects protruding from the luggage compartment change the vehicle length and may possibly endanger other road users. This can cause accidents and serious or fatal injuries.

- Follow the legal regulations.
- Mark objects sticking out of the luggage compartment so they will be visible to others on the road.
- Never use the trunk lid to secure or wedge objects.

WARNING

Among other substances, engine exhaust gases contain carbon monoxide, an odorless and colorless poisonous gas. If driving with the trunk lid open, poisonous exhaust may enter the vehicle interior, leading to a loss of consciousness, carbon monoxide poisoning, accidents and serious or fatal injuries.

- To prevent poisonous exhaust from entering the vehicle, always drive with the trunk lid closed.
- Close all windows.
- Close the power sunroof.
- Switch off recirculation mode.
- Open all the air vents in the instrument panel.
- Switch the blower to the highest blower level.
- Always drive with the trunk lid closed if the load can be transported with the trunk lid closed.

NOTICE

Opening the trunk lid changes the height and possibly the length of the vehicle. This can cause damage to the vehicle if driving carelessly.

- Be aware of the changed outer dimensions, such as when driving through underpasses.

Driving through water on roads

Note the following to reduce the risk of vehicle damage when driving through water, for example on flooded roads:

- The water must not be any higher than the bottom of the vehicle body ⇒ .
- Do not drive faster than walking speeds.

- Never stop the vehicle, drive in reverse, or stop the engine in water.
- Oncoming vehicles create waves that can raise the water level for your vehicle enough that it is not safe to drive through
- Always manually deactivate the start-stop system when driving through water ⇒ *Start/Stop system*.

WARNING

When driving through water, mud, slush, etc., the braking effect may be delayed due to damp or icy brake rotors and brake pads in the winter, and this can extend the braking distance. This could cause a loss of vehicle control, accidents and serious or fatal injuries.

- Perform careful braking maneuvers to dry and remove ice from the brakes.
- Do not endanger road users or disregard legal regulations during braking maneuvers.
- Avoid abrupt and sudden braking maneuvers directly after driving through water.

NOTICE

Driving through water can greatly damage or corrode parts of the vehicle, e.g. electronics.

- Never drive through salty water.
- Using fresh water, immediately rinse any parts of the vehicle that may have come into contact with salty water.
- Protect electronic components against contact with water.

Operating the vehicle in different countries and continents

Approval regulations

The vehicle was manufactured by the factory for a specific country and meets those requirements and approval regulations that were valid at the time of vehicle manufacture ⇒ .

 If the vehicle will be used temporarily or for a brief period in another country, then read and observe the following information.

Safety standards and regulations

Some countries have special safety standards and regulations that differ from the vehicle configuration. Volkswagen recommends obtaining information about legal regulations from an authorized Volkswagen dealer or authorized Volkswagen Service Facility before driving in other countries.

Selling in other countries

If the vehicle is sold in another country or will be used for an extended period in another country, then the applicable legal regulations in that country must be observed.

Certain equipment may need to be installed or removed and functions may need to be deactivated. The scope and types of service may also be affected. This particularly applies if the vehicle is being operated for an extended period in a different climate region.

Functions of the Infotainment system

Due to the many different frequency bands around the world, the Infotainment system installed at the factory may not function in other countries.

 Volkswagen is not responsible for damage to the vehicle caused by substandard fuel, insufficient service, or not using Volkswagen Genuine parts.

 Volkswagen is not responsible if the vehicle does not meet all of the applicable legal requirements in other countries and continents.

 **WARNING**

At high altitudes, the air density is lower. Due to the reduced air density, engine power may be reduced and when in operation for extended periods at high altitudes, vehicle components may be damaged. Lower engine power can result in accidents, e.g. when overtaking, and may result in serious or fatal injuries.

- Before driving abroad, obtain information from a suitably qualified professional, particularly for altitudes above 3000 m (around 9843 ft) above sea level. Volkswagen recommends contacting an authorized Volkswagen dealer or authorized Volkswagen Service Facility.

Driver assistance systems

Sensor system information

Introduction

Depending on the vehicle equipment, the vehicle has driver assistance systems that increase driving convenience. Some of these driver assistance systems use sensors or cameras (hereafter referred to as the “sensor system”) that are not or only partially visible to you.

The sensors and cameras visually detect the vehicle's surroundings ultrasonically or by using radar waves.

Installed sensor systems

Depending on the vehicle equipment, the following sensor systems may be installed:

- Radar sensor in the front of the vehicle.
- Radar sensors in the rear of the vehicle.
- Camera behind the windshield.
- Ultrasonic sensors in the front of the vehicle.
- Ultrasonic sensors in the rear of the vehicle.



 You can find information on the relevant installation location in the vehicle overviews ⇒ [Vehicle overviews](#).

WARNING

The driver assistance systems are not a replacement for the driver's attention and work only within their system limitations. The driver assistance systems cannot detect all driving situations and may not provide warnings or react, or may provide warnings or react with a delay, or may provide warnings or react in a way that is not desired. If you are careless, there is a risk of accidents, serious injuries and death.

- Always stay attentive and do not rely solely on the system. The driver is always responsible for control of the vehicle.
- Be aware of the limits of the sensor system and the system limitations of the individual systems.
- Always adapt your speed and distance to vehicles driving ahead based on the visual, weather, road, and traffic conditions.
- Be prepared to override or interrupt automatic interventions at all times.
- Pay attention to indicators in the instrument cluster display and respond to the displays accordingly when the traffic situation allows.
- Do not use driver assistance systems if you suspect a problem or damage.

Limits of the sensor system

 Please read the introductory information and heed the Warnings and Notice ⇒  [Introduction](#).

Limits of the radar sensor

Driver assistance systems that use radar sensors may not respond, may offer a delayed response or may respond in an

unexpected way in the following situations:

- When driving in poor weather conditions, such as heavy rain, snow or heavy spray.
- When driving through construction zones, tunnels or toll stations.
- When driving on winding roads, for example, mountain roads
- In front of bumps or dips in the road
- When driving off-road
- When driving in parking ramps
- When driving on roads with embedded metal objects, such as railroad tracks
- When driving on gravel roads
- In complex driving situations, such as traffic islands.
- Following a violent impact affecting components within the range of the radar sensors, e.g. following a rear-end collision.
- The radar sensors are obscured, dirty, misaligned or damaged.

Limits of the camera behind the windshield

Driver assistance systems that use the camera behind the windshield may not respond, may offer a delayed response or may respond in an unexpected way in the following situations:

- In front of bumps or dips in the road
- When driving in construction zones
- When driving off-road
- When driving in poor weather conditions, such as heavy rain, snow, fog or heavy spray and poor road conditions.
- In low-lying sun, darkness or if there is glare from oncoming vehicles.
- The camera is not available due to long exposure to direct sunlight or high ambient temperatures.
- The camera field of view is obscured, dirty or damaged.
- The camera is misaligned.

Delayed reaction

If the sensor system is exposed to environmental conditions that limit its function, the driver assistance systems may only be able to detect this with a delay. Therefore, the display that indicates that functions are impaired may be delayed when you first start driving or while driving.

Limits in certain driving situations

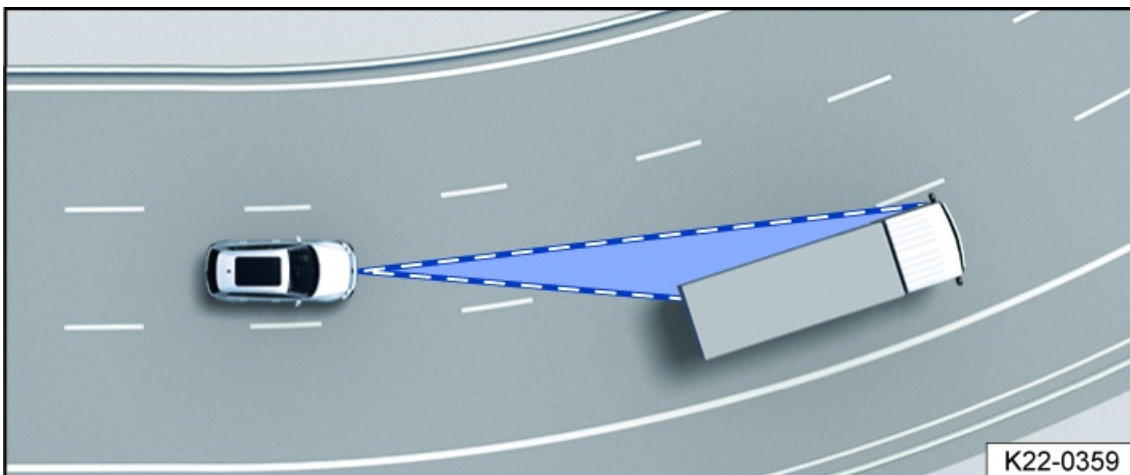

Fig. 101 Driving around curves.

The sensor system always measures straight ahead. Therefore, on tight curves, vehicles may be detected by mistake or vehicles driving ahead may not be detected.

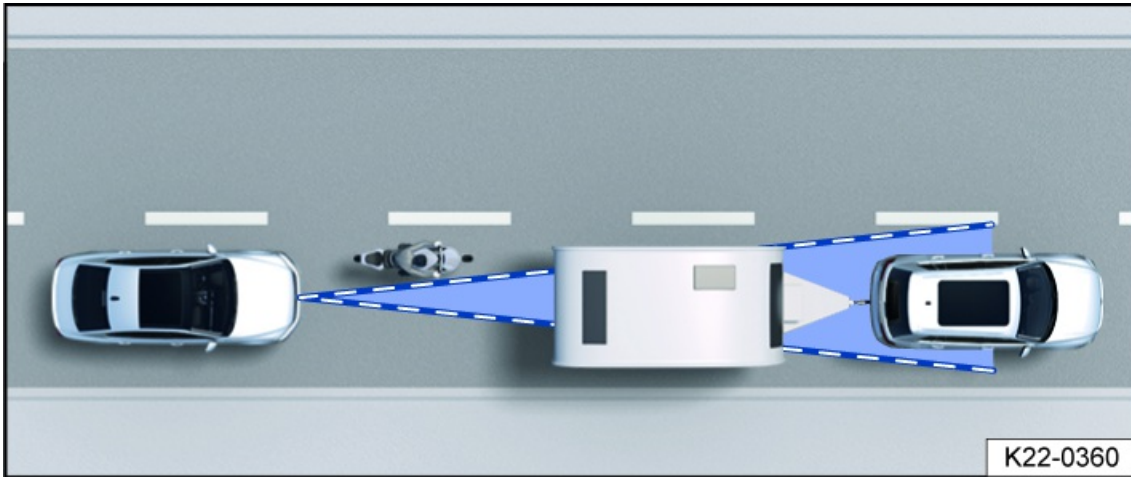

Fig. 102 Narrow vehicle.

Vehicles that are driving close to your vehicle but outside the sensor range, such as motorcycles, cannot be detected.

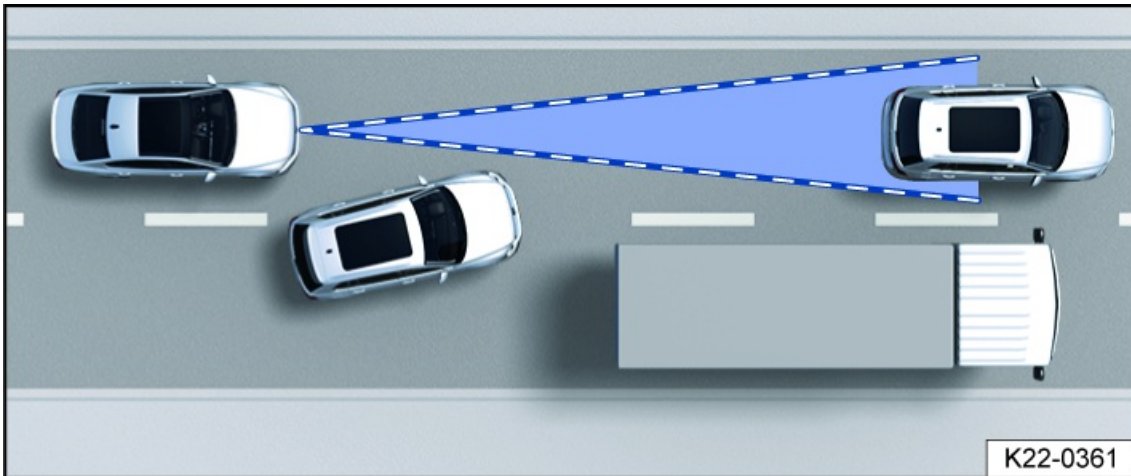



Fig. 103 Changing lanes.

Vehicles that change to your lane close in front of your vehicle cannot be detected. This also applies to vehicles with attachments exceeding the vehicle dimensions.

Specific system limitations

In addition to the limits of the sensor system, every driver assistance system has additional system limitations linked to their function. Please also note these:

- Adaptive Cruise Control (ACC) ⇒ *ACC system limitations*.
- Predictive cruise control ⇒ *System Limitations of Predictive Cruise Control*.
- Autonomous Emergency Braking (Front Assist) ⇒ *Front Assist system limitations*.
- Lane Assist ⇒ *Lane Assist system limitations*.
- Comfort drive Travel Assist ⇒  *Introduction*.
- Emergency Assist ⇒  *Introduction*.
- Lane Change System (Side Assist) ⇒ *Side Assist system limitations*.

Troubleshooting

 Please read the introductory information and heed the Warnings and Notice ⇒  *Introduction*.

No forward sensor range or limited forward sensor range

Parts of the sensor systems in the front of the vehicle have limited availability or are not available. The yellow symbol and a message are displayed for a few seconds.

- The sensor areas are dirty or the sensor system's view is limited due to weather conditions, such as snow, or from detergent residue or coatings. Clean the sensor areas in the front of the vehicle and clean the windshield ⇒ [Vehicle care](#)
- The sensor areas are impaired by attachments, decorative frames on license plate holders, or labels. Keep the areas around the sensor system clear ⇒ [Sensors and Cameras](#).
- The sensor system is misaligned or damaged, for example as a result of damage to the front of the vehicle or the windshield. Check if there is noticeable damage ⇒ [Sensors and Cameras](#).
- Painting work was carried out on or structural modifications were made to the front of the vehicle or the windshield ⇒ [Repairs and technical modifications](#).
- Malfunction or fault. Stop the engine and restart.
- If the problem persists, contact an authorized Volkswagen dealer or authorized Volkswagen Service Facility. Volkswagen recommends contacting an authorized Volkswagen dealer or authorized Volkswagen Service Facility.

 If the sensor range is restricted, driver assistance systems may not be available or only to a limited extent. Refer to the other indicator lights of the driver assistance systems ⇒ [Symbols in the instrument cluster](#).

 Additional information may be displayed in the vehicle status, depending on the malfunction ⇒ [Vehicle settings menu](#).

Adaptive Cruise Control (ACC)

Introduction

Adaptive Cruise Control (ACC) maintains your selected speed. When the vehicle approaches a vehicle driving ahead, the ACC adjusts the speed automatically and maintains your set distance to the vehicle driving ahead.

Does this vehicle have ACC?

The vehicle has ACC if you can adjust ACC settings in the Assistance systems menu in the Infotainment system.

Speed range

You can set a speed of between 20 km/h (15 mph) and 210 km/h (130 mph). The maximum speed that you can set may be lower, depending on the vehicle equipment and country.

Driving with ACC

You can override the ACC system at any time. The regulation function is canceled when you apply the brakes. When you accelerate, the regulation function is paused while accelerating and then resumed with the speed set.

If a trailer is hitched, ACC is less dynamic.

Driver intervention request



 If automatic deceleration by the ACC is not sufficient or the system limits are reached, the ACC will prompt you – with a message in the instrument cluster – to also apply the brakes. The red warning light will also turn on and a warning tone will sound. Take over steering and be ready to brake.



ACC is not a replacement for the driver's attention and works only within the system limitations. ACC cannot detect all driving situations and may not react, or may react with a delay, or may react in a way that is not desired. If you are careless, there is a risk of accidents, serious injuries and death.

- Always stay attentive and do not rely solely on the system. The driver is always responsible for control of the vehicle.
- Observe the system limitations ⇒ *ACC system limitations*.
- Always adapt your speed and distance to vehicles driving ahead based on the visual, weather, road, and traffic conditions.
- Take over steering immediately if a driver intervention prompt appears in the instrument cluster display or the deceleration by ACC is not sufficient.
- Apply the brakes if the vehicle continues to roll unintentionally, e.g. after a driver intervention prompt.

Special driving situations

 Please read the introductory information and heed the Warnings and Notice ⇒  *Introduction*.
The functions described below depend on the vehicle equipment and are not available in all countries.

Predictive ACC

If the vehicle has a Dynamic Road Sign Display and an Infotainment system with navigation, ACC can adjust the speed to recognized speed limits and the route history.

Stop-and-go traffic

ACC can brake the vehicle and bring it to a standstill. ACC remains active, and the instrument cluster display shows ACC is ready for a few seconds.

Vehicles with comfort drive Travel Assist: You can extend this time by continuing to hold the steering wheel.

As long as ACC remains active, the vehicle will automatically move again once the vehicle driving ahead starts and if no obstacle has been detected.

Extend drive-readiness or reactivate:

1. Press the  button.

Or: Vehicles with comfort drive Travel Assist: Take hold of the steering wheel again.

Driving off when drive-readiness has ended and the vehicle driving ahead has already started moving:

1. Press the  button.

Or: briefly press the accelerator pedal.

The ACC does not stay active in the following scenarios:

- The stationary phase lasts several minutes.
- The driver door is opened.
- The ignition is switched off.

WARNING

If ACC is ready appears in the instrument cluster display and the vehicle driving ahead starts to move, your vehicle will start driving automatically. The vehicle may not be able to detect obstacles in the vehicle's path when this happens. This may cause accidents and serious injuries.

- Check the vehicle's path every time before you start driving and brake the vehicle if necessary.

ACC system limitations

📖 Please read the introductory information and heed the Warnings and Notice ⇒ ⚠️ *Introduction*.

Limits of the sensor system

ACC detects driving situations using the radar and ultrasonic sensors in the front of the vehicle and the camera behind the windshield. The radar sensor has a range of up to approx. 160 m (approx. 520 ft).

⚠️ WARNING

If you use the ACC in situations outside system limitations, accidents and serious injuries may result and legal regulations may be violated.

- Be aware of the limits of the sensor system ⇒ *Limits of the sensor system* and stop the regulation function in the specified situations.

Unrecognizable objects

ACC only detects vehicles that are moving in the same direction or are stationary. The following will not be detected:

- Pedestrians
- Animals
- Vehicles crossing the street or oncoming vehicles
- Other stationary obstacles

Stationary vehicles

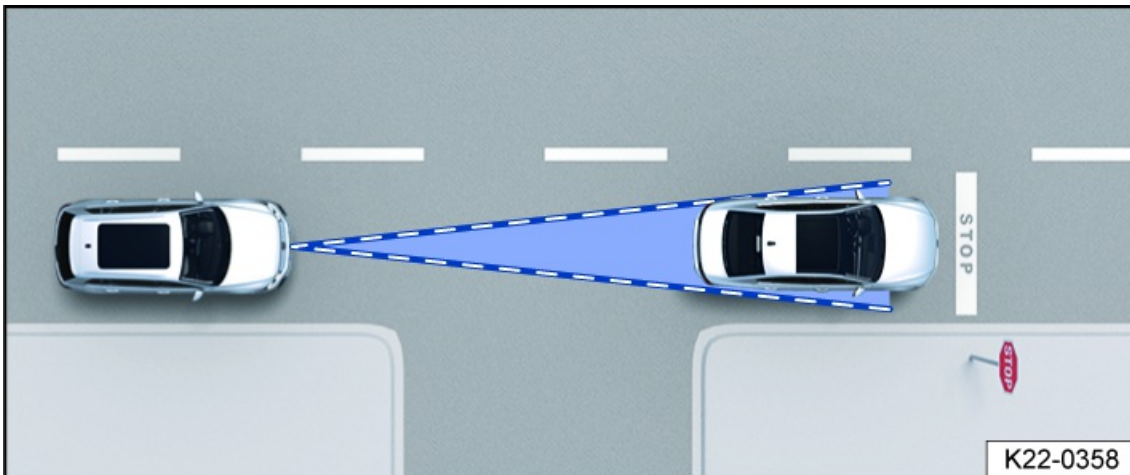

Fig. 104 Stationary vehicle.

Up to a speed of about 60 km/h (about 37 mph) ACC only responds to a limited extent to stationary vehicles if a stationary vehicle is detected as such and the vehicle you are driving can be conveniently braked behind the stationary vehicle within the system limitations of ACC. ACC does not perform emergency braking *fig. 104*.

The reaction to stationary vehicles depends on the vehicle equipment and is not available in all countries.

Switching ACC on and off

📖 Please read the introductory information and heed the Warnings and Notice ⇒ ⚠️ *Introduction*.



Fig. 105 Left side of the multi-function steering wheel.

Switching on

1. Press the  button.

ACC is not yet functioning.





Starting the regulation function

1. Press the **SET** button while driving forward.

ACC saves the current speed and maintains the set distance. If the current speed is outside the specified speed range, the ACC adjusts the minimum speed when driving too slowly or the maximum speed when driving too quickly.

Relevant braking assistance systems are also activated ⇒ [Switching the braking support system on and off](#).

The following indicator lights may turn on depending on the driving situation:

 *ACC is regulating – no vehicle ahead detected.  *ACC is regulating – vehicle ahead detected.  *ACC is not regulating – no vehicle is detected driving ahead.  *ACC is not regulating – a vehicle is detected driving ahead.

Canceling the regulation function

1. Press the  button briefly.

Or: press the brake pedal while driving.

If the respective indicator light for the driving situation lights up gray, the speed and distance are saved.

If a relevant braking assistance system is deactivated, the control will be canceled automatically ⇒ [Switching the braking support system on and off](#).

Resuming the regulation function

1. Press the **RES** button.



ACC assumes the last set speed and the last set distance. The instrument cluster display shows the set speed, and indicator lights turn on corresponding to the driving situation.

Switching off

1. Press and hold the  button.

The set speed is deleted.

Adjusting the ACC settings

 Please read the introductory information and heed the Warnings and Notice ⇒  *Introduction*.

Setting the distance

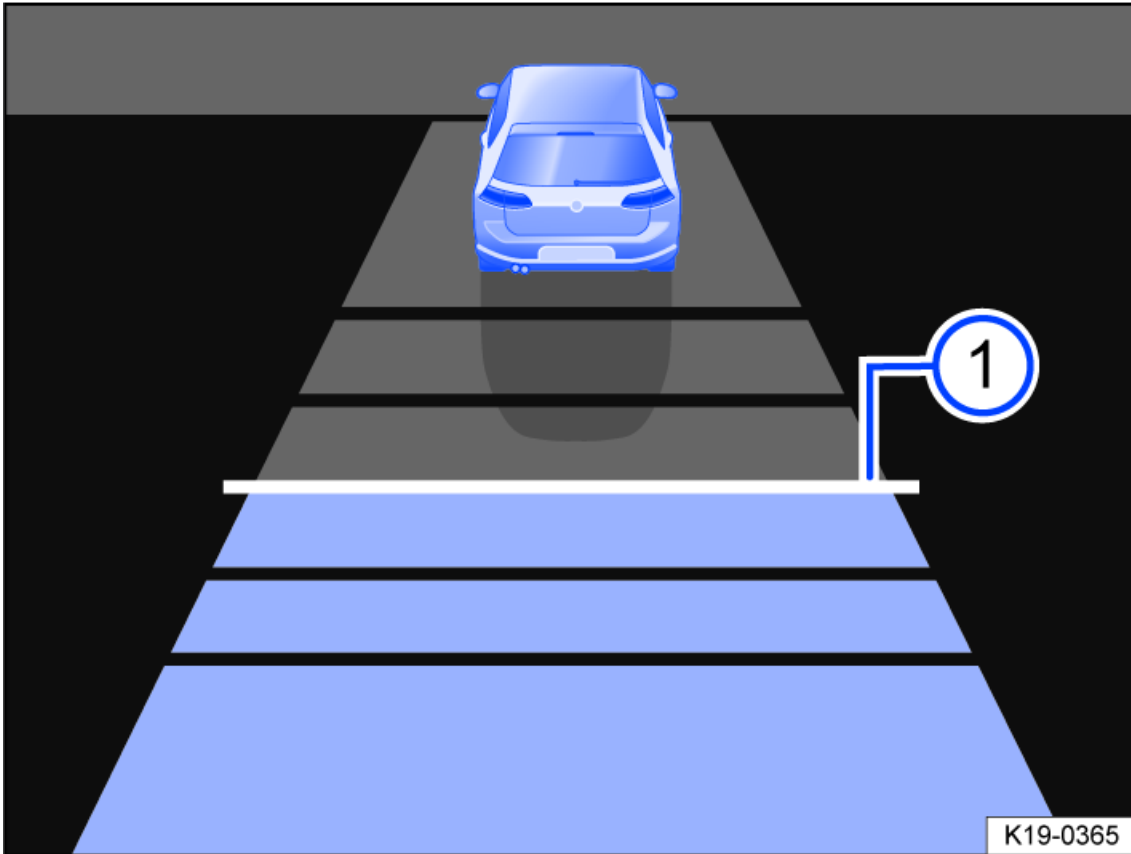





Fig. 106 In the instrument cluster display: set distance during control (general example).

You can set the distance at five levels from very short to very long:

1. Press the  button.
2. Press the  or  button.

Or: Press the  button repeatedly until the preferred distance is set.

The instrument cluster display shows the selected level *fig. 106*. Heed the country-specific regulations for minimum distance.

In the Assistance systems menu of the Infotainment system, you can choose whether you want the regulation to start at the distance that was set at the end of the journey or start at a preselected distance.

If ACC is not regulating, the set distance and the vehicle will not be highlighted on the instrument cluster display.

Setting the speed

You can adjust the stored speed within the specified speed range using the buttons on the multi-function steering wheel as follows:

+ 1 km/h (1 mph): Press the  button.

- 1 km/h (1 mph): Press the  button.

+ 10 km/h (5 mph):

Press and hold the  button. Pressing for the first time changes to the next-largest tens digit (km/h) or fives digit (mph).

- **10 km/h (5 mph):** Press and hold the  button. Pressing for the first time changes to the next-smallest tens digit (km/h) or fives digit (mph).

WARNING

ACC cannot detect all driving situations correctly. If the vehicle is less than the minimum distance from the vehicle ahead and the difference in speed between the vehicle ahead and your own vehicle is so great that the speed deceleration from the ACC is not sufficient, there is a risk of a rear end collision. This may result in serious injury or even death.

- Always be ready to apply the brakes yourself.
- To override the predictive cruise control and Adaptive Cruise Control (ACC), press the accelerator pedal. In this case, ACC will not brake automatically.
- Heed the country-specific regulations regarding minimum distance.
- Always set a longer distance when there is rain, snow, or poor visibility.

Adjusting the regulation function system settings

You can influence how dynamically ACC takes control:



- Vehicles with Driving Mode Selection:
Select the desired driving mode.
- Vehicles without Driving Mode Selection:
Select the desired driving mode in the Assistance systems menu in the Infotainment system.

Deactivating distance control

1. Press the  button.
2. Select Control system in the instrument cluster display.

Distance control is deactivated. The vehicle only maintains the set speed.

Troubleshooting

 Please read the introductory information and heed the Warnings and Notice ⇒  [Introduction](#).

ACC is not available

The yellow indicator light turns on. In addition, a message is shown in the instrument cluster display.

- The radar sensor is dirty. Clean the radar sensor ⇒ [Vehicle care](#).
- The visibility of the radar sensor is limited due to weather conditions, such as snow, or from soap residue or coatings. Clean the radar sensor ⇒ [Vehicle care](#).
- Radar sensor visibility is limited by attachments, decorative frames on license plate holders, or stickers. Clear the area around the radar sensor ⇒ [Sensors and Cameras](#).
- The radar sensor is misaligned or damaged, for example as a result of damage to the front of the vehicle. Check if there is noticeable damage ⇒ [Sensors and Cameras](#).
- Malfunction or fault. Stop the engine and restart.
- Painting work was carried out on or structural modifications were made to the front of the vehicle ⇒ [Repairs and technical modifications](#).

- The original Volkswagen emblem is not used. Volkswagen recommends the use of Volkswagen original parts or Volkswagen original accessories, which you can acquire from an authorized Volkswagen dealer or authorized Volkswagen Service Facility.
- If the problem persists, contact an authorized Volkswagen dealer or authorized Volkswagen Service Facility. Volkswagen recommends contacting an authorized Volkswagen dealer or authorized Volkswagen Service Facility.

ACC is not functioning as expected

- The radar sensor is dirty. Clean the radar sensor ⇒ [Vehicle care](#).
- The ultrasonic sensors are dirty, obscured or damaged. Clean the ultrasonic sensors ⇒ [Vehicle care](#).
Clear the area around the ultrasonic sensors and check if there is noticeable damage ⇒ [Sensors and Cameras](#).
- The system limitations are not adhered to ⇒ [ACC system limitations](#).
- The brakes are overheating, and the regulation function has been automatically canceled. Let the brakes cool down and check the function again.
- If the problem persists, contact an authorized Volkswagen dealer or authorized Volkswagen Service Facility. Volkswagen recommends contacting an authorized Volkswagen dealer or authorized Volkswagen Service Facility.

 Additional information may be displayed in the vehicle status, depending on the malfunction ⇒ [Vehicle settings menu](#).

The Adaptive Cruise Control cannot start

Make sure the following requirements are met:

- A gear is engaged for driving forward.
- The brake lights on the vehicle are functioning.
- The brake lights on the electronically connected trailer are functioning.
- ESC is not regulating.
- The brake pedal is not being pressed.

Unusual noises during automatic braking

This is normal and not a cause for concern.

Controls are responding differently than expected

Moisture, dirt and grease may limit the functioning of the controls.

1. Always keep the control panels clean and dry.

Predictive ACC

Introduction

Predictive cruise control adapts the vehicle's speed to known speed limits and to the road layout ahead (e.g. bends, intersections and roundabouts).

Predictive cruise control is an extension of ACC and uses the Dynamic Road Sign Display system and the navigation data from the Infotainment system.

Predictive cruise control depends on the vehicle equipment and is not available in all countries.





Predictive cruise control is not a replacement for the driver's attention and works only within the system limitations.

Predictive cruise control cannot detect all enforced maximum speed limits and may not react, or may react with a delay, or may react in a way that is not desired. If you are careless, there is a risk of accidents, serious injuries and death.

- Always stay attentive and do not rely solely on the system. The driver is always responsible for the stored speed of the vehicle.
- Observe the system limitations ⇒ [System Limitations of Predictive Cruise Control](#).
- Always adapt your speed to the visibility, weather, road and traffic conditions.
- Keep the navigation data up to date.
- Always observe the maximum permissible speed.
- Note that the speeds regulated by the system do not necessarily conform to your driving style.

 Also observe the system limitations of and information on ACC.

System Limitations of Predictive Cruise Control

 Please read the introductory information and heed the Warnings and Notice ⇒  [Introduction](#).

Beside the system limitations of the Dynamic Road Sign Display system and the system limitations of the ACC, predictive cruise control also has the following additional, system-based limitations:

- Predictive cruise control only detects road signs that display a speed limit. In particular, predictive cruise control does not detect priority rules or traffic lights.
- Road signs that display a speed limit indirectly, such as city limit signs, are only detected on the basis of the navigation data.
- Road signs with additional signs that, for example, show time limits are only taken into consideration if they are included in the navigation data.
- The predictive cruise control function is not available on roads that are either not included or not mapped with complete accuracy in the navigation data.
- If a speed limit is announced on the basis of the navigation data but not detected by the Dynamic Road Sign Display, the announced speed is reset to the speed last saved.
- Predictive cruise control cannot take over speeds below the minimum speed ⇒  [Introduction](#).

Functional limitations

In the following situations, the predictive cruise control may not change the speed, may change it with a delay or in a way that is not desired:

- Dynamic Road Sign Display is malfunctioning. No speed limit  is displayed in the instrument cluster display.
- Road signs are not being detected or are not being detected correctly.
- The navigation data are out of date.
- You are driving without route guidance.
- You deviate from the route calculated by the navigation system.
- The position of the vehicle cannot be determined correctly due to inaccurate GPS data.

Activating the predictive cruise control

 Please read the introductory information and heed the Warnings and Notice ⇒  [Introduction](#).

You can set the events to which the vehicle should respond:

- Response to road layout.



- Response to permissible speed.

In the Infotainment system:

1. Open the Assistance systems menu.
2. Select Adaptive Cruise Control (ACC).
3. Configure the desired setting.

If you have activated at least one event, predictive cruise control will be automatically switched on as well when ACC is switched on.

Driving with predictive cruise control

 Please read the introductory information and heed the Warnings and Notice ⇒  [Introduction](#).

Driving with Route Guidance

If you drive with route guidance, predictive cruise control will adjust the speed to the route you have entered in the system.

Driving without Route Guidance

If you drive without route guidance, predictive cruise control will adjust the speed to the most likely route.

Displays

As soon as the system detects a speed limit or is going to reduce your speed due to the road layout, a notification appears in the instrument cluster display. This message shows the reason and the speed to which the vehicle will adjust.

 Adjustment due to a speed restriction.  Adjustment due to the road layout.

If the speed is adjusted due to a speed limit, the detected speed will be saved as a new desired speed. If the speed is adjusted due to the road layout, the vehicle will accelerate to the previously saved preferred speed afterwards.

Cornering speed notifications depend on the driving mode ⇒ [4MOTION Active Control](#).

To cancel speed adjustment

During the notification:

1. Press the  button.

During the adjustment:

1. Press the  button.

Adjusting the speed shown

The speed shown can only be adjusted when controlled due to speed restrictions.

+ 1 km/h (1 mph): Press the  button.

- 1 km/h (1 mph): Press the  button.

+ 10 km/h (5 mph): Press and hold the  button. Pressing for the first time changes to the next-largest tens digit (km/h) or fives digit (mph).

- 10 km/h (5 mph): Press and hold the  button. Pressing for the first time changes to the next-smallest tens digit (km/h) or fives digit (mph).



If you adjust the speed shown in the notification too far, the predictive cruise control will be canceled.

 If a speed limit is detected, the predictive cruise control system will adjust the saved speed, even if ACC is deactivated. However, it does not take control.

 If a speed limit on a highway is lifted, the recommended speed will automatically be saved as the preferred speed.

However, if a higher speed than the recommended speed was previously saved on a highway with no speed limit, this saved speed will be applied instead of the recommended speed.

Troubleshooting

 Please read the introductory information and heed the Warnings and Notice ⇒  [Introduction](#).

A notification shows that the predictive speed limit control is currently unavailable or is not available in your country

1. If the message is displayed over a longer period and predictive cruise control is available in your country, seek assistance from suitably qualified professionals. Volkswagen recommends contacting an authorized Volkswagen dealer or authorized Volkswagen Service Facility.

 Additional information may be displayed in the vehicle status, depending on the malfunction ⇒ [Vehicle settings menu](#).

Autonomous Emergency Braking (Front Assist)

Introduction

Front Assist can recognize impending forward collisions and warn the driver. In addition, the system can provide support when braking and initiate an automatic braking maneuver.

The Front Assist system can help to avoid accidents but cannot replace the driver's attention.

Front Assist works solely within the system limitations. Warning times vary depending on the Traffic Situation and the driving behavior.

Range of functions

Front Assist includes the following additional functions, depending on the vehicle equipment and the country:

- Pedestrian Monitoring.
- Cyclist Monitoring.

The functions named are automatically active if Front Assist is switched on.

Recognizable objects

Autonomous Emergency Braking (Front Assist) can recognize the following objects, depending on the vehicle equipment and the country:

- Vehicles.
- Bikes.
- Pedestrians.

Driving with Front Assist

You can cancel automatic braking interventions by moving the steering wheel or pressing the accelerator pedal.

Automatic braking

Front Assist can brake the vehicle to a stop. The vehicle will not be held at a stop after that. Press the brake pedal.

The brake pedal feels more firm during an automatic braking maneuver.



WARNING

Front Assist is not a replacement for the driver's attention and works only within the system limitations. Front Assist cannot

detect all driving situations and may not react, may react with a delay, or may react in a way that is not desired. If you are careless, there is a risk of accidents, serious injuries and death.

- Always stay attentive and do not rely solely on the system. The driver is always responsible for control of the vehicle.
- Observe the system limitations ⇒ *Front Assist system limitations*.
- Always adapt your speed and distance to vehicles driving ahead based on the visual, weather, road, and traffic conditions.
- Consider interrupting automatic Autonomous Emergency Braking (Front Assist) interventions if necessary.
- When Front Assist warns you, brake the vehicle immediately or maneuver around the obstacle, depending on the driving situation.
- If you are unsure which functions are included with your vehicle depending on the vehicle equipment and country, consult suitably qualified professionals before starting your journey. Volkswagen recommends contacting an authorized Volkswagen dealer or authorized Volkswagen Service Facility.

Warning levels and braking support

 Please read the introductory information and heed the Warnings and Notice ⇒  *Introduction*.

Speed ranges

Front Assist assists in these maximum speed ranges:

- Response to vehicles: Approx. 5 km/h (approx. 3 mph) to approx. 250 km/h (approx. 155 mph).
- Response to bikes: Approx. 5 km/h (approx. 3 mph) to approx. 250 km/h (approx. 155 mph).
- Response to pedestrians: Approx. 5 km/h (approx. 3 mph) to approx. 85 km/h (approx. 53 mph).

The support system can involve an advance warning, an immediate warning, automatic braking or braking support. A distance warning may also be displayed.

Influencing factors



Whether and in which speed range Automatic Emergency Braking (Front Assist) reacts to the named objects is dependent on the following factors:

- Type of object.
- Movement direction of the object.
- Speed of the object.
- Speed of the vehicle.

The work area can therefore be limited if the vehicle approaches an object very quickly and thus has little time to react.

Furthermore, not all warning levels are passed through in all situations. Depending on the speed, there may not be, for example, an advance warning or immediate warning, but rather an automatic braking maneuver that occurs straight away, so as to best protect the detected object.

Distance warning

   Front Assist detects if there is a safety hazard from following the vehicle ahead too closely. The indicator light turns on. Increase the distance.

Advance warning

 Front Assist detects a possible collision and prepares the vehicle for possible emergency braking. A warning tone sounds and the warning light turns on. Apply the brakes or maneuver to avoid the collision.

Immediate warning

If you do not respond to the advance warning, the brakes may be applied briefly to indicate the increasing risk of a collision. Apply the brakes or maneuver to avoid the collision.



Automatic braking

Automatic Emergency Braking (Front Assist) can brake the vehicle automatically in several stages of increasing braking force. Reducing the vehicle speed may help to reduce the damage resulting from a collision.

Braking support

If the system detects that you are not braking enough before an impending collision, Front Assist can increase the braking force and thus help to reduce the risk of a collision. The braking support is only active as long as you are firmly pressing the brake pedal.

Front Assist system limitations

 Please read the introductory information and heed the Warnings and Notice ⇒  [Introduction](#).

Limits of the sensor system

Front Assist detects driving situations using a radar sensor in the front of the vehicle and the camera behind the windshield.

 Note the limitations of the sensor system ⇒ [Limits of the sensor system](#). Always be attentive and intervene yourself if necessary!

After starting the vehicle

 Front Assist is not available or its availability is limited immediately after starting the vehicle. During this time, the white indicator light in the instrument cluster display comes on.

Unrecognizable objects

Automatic Emergency Braking (Front Assist) may not react or may react with a delay to the following objects:

- If there are oncoming vehicles or vehicles crossing the street
- Oncoming pedestrians; generally no reaction to people without Pedestrian Monitoring.
- Stationary or oncoming cyclists; also no reaction to cyclists crossing the road without Cyclist Monitoring.
- Pedestrians and cyclists who are not detected as such, for example because they are fully or partially hidden.
- Animals

Functional limitations

In addition to the situations specified in the sensor system limitations, Front Assist may not react, may react with a delay, or may react in a way that is not desired in the following situations, among others:

- When driving in reverse
- If ESC is regulating or is malfunctioning.
- If multiple brake lights on the vehicle are malfunctioning.
- If there is a malfunction in at least one brake light on an electrically connected trailer or bicycle rack.
- If the vehicle is accelerating very quickly or the accelerator pedal is pressed all the way down.
- In unclear traffic situations, for example if vehicles driving ahead are braking quickly or are turning
- When entering or exiting a tunnel.
- If Front Assist is malfunctioning

Switching off Front Assist

Depending on the system, Front Assist may not be suitable in the following situations and must be switched off if they occur





- If the vehicle is not being driven on public roads, for example during off-road driving or on a racetrack.
- If the vehicle is being towed or transported
- If add-ons cover the radar sensor or camera.
- If the camera or radar sensor is malfunctioning.
- Following a violent impact affecting components within the range of the radar sensor, e.g. following a rear-end collision.
- If the windshield is damaged in the camera field of view.
- If there are multiple unwanted activations

WARNING

Using Front Assist in these situations may result in accidents and serious or fatal injuries.

- Switch off Front Assist in the specified situations.

Using Front Assist

 Please read the introductory information and heed the Warnings and Notice ⇒  [Introduction](#).

When you switch on the ignition, Front Assist with all of its equipment- and country-dependent functions is automatically switched on.

 However, Front Assist is not available or its availability is restricted while the white indicator light is turned on.

Volkswagen recommends always leaving Front Assist and all of its equipment- and country-dependent functions switched on.

Exceptions ⇒ [Front Assist system limitations](#).

Switching on and off

You can manually switch the Automatic Emergency Braking (Front Assist) on and off.

In the Infotainment system:

1. Open the Assistance systems menu.
2. Switch Automatic Emergency Braking on or off in the corresponding submenu.

 If you switch off Front Assist, all of its equipment- and country-dependent functions are also switched off. The yellow indicator light turns on in the instrument cluster display.



If Front Assist was automatically deactivated, e.g. if towing is detected, the yellow indicator light also comes on.

Settings

If Front Assist is switched on, you can set the following settings in the Assistance systems menu of the Infotainment system:

- Switch on and off distance warning.

Troubleshooting

 Please read the introductory information and heed the Warnings and Notice ⇒  [Introduction](#).

Automatic Emergency Braking starts

The white indicator light comes on.

- Automatic Emergency Braking (Front Assist) is temporarily not available or has limited availability. After driving straight for a short distance, Automatic Emergency Braking is available again and the indicator light goes out. If the vehicle does not

drive, the indicator light stays on.

Automatic Emergency Braking (Front Assist) not available or has limited availability

The yellow indicator light turns on. In addition, a message is shown in the instrument cluster display.

- The radar sensor or camera field of view is dirty. Clean the radar sensor and windshield ⇒ [Vehicle care](#).
- The visibility of the radar sensor or camera is limited due to weather conditions, such as snow, or from soap residue or coatings. Clean the radar sensor and windshield ⇒ [Vehicle care](#).
- Radar sensor visibility is limited by attachments, decorative frames on license plate holders, or stickers. Clear the area around the radar sensor ⇒ [Sensors and Cameras](#).
- The camera's view is limited by attachments or stickers. Keep the area around the camera field of view clear ⇒ [Sensor and Cameras](#).
- The radar sensor or the camera is misaligned or damaged, for example as a result of damage to the front of the vehicle or the windshield. Check if there is noticeable damage ⇒ [Sensors and Cameras](#).
- The camera was automatically deactivated due to a high ambient temperature or long exposure to direct sunlight. Front Assist will be available once the camera is available again.
- Painting work was carried out on or structural modifications were made to the front of the vehicle ⇒ [Repairs and technical modifications](#).
- The original Volkswagen emblem is not used. Volkswagen recommends the use of Volkswagen original parts or Volkswagen original accessories, which you can acquire from an authorized Volkswagen dealer or authorized Volkswagen Service Facility.
- If the problem persists, turn off Automatic Emergency Braking and contact suitably qualified professionals. Volkswagen recommends contacting an authorized Volkswagen dealer or authorized Volkswagen Service Facility.

Front Assist is not functioning as expected or has been triggered multiple times unnecessarily

- The sensor system does not work properly. Check remedial measures for non-availability or limited availability → page , [Troubleshooting](#).
- The system limitations are not adhered to ⇒ [Front Assist system limitations](#).
- Low-lying sun or darkness.
- If the problem persists, turn off Automatic Emergency Braking and contact suitably qualified professionals. Volkswagen recommends contacting an authorized Volkswagen dealer or authorized Volkswagen Service Facility.

Controls are responding differently than expected

Moisture, dirt and grease may limit the functioning of the controls.

1. Always keep the control panels clean and dry.

Lane Keeping System (Lane Assist)

Introduction

Lane Assist helps the driver to stay in a lane, within the system limitations. This function is not suitable for, and not designed for, autonomously keeping your vehicle in a lane.

If the system detects that the vehicle is coming too close to a lane marker, Lane Assist warns the driver with corrective steering. The driver can override the corrective steering at any time.

Speed range



Lane Assist is ready to take control (active system status) when a lane marking is detected within the system limits above approximately 60 km/h (approximately 35 mph).

WARNING

Lane Assist is not a replacement for the driver's attention and works only within the system limitations. Lane Assist cannot detect all driving situations and may not react, may react with a delay, or may react in a way that is not desired. If you are careless, there is a risk of accidents, serious injuries and death.

- Always stay attentive and do not rely solely on the system. The driver is always responsible for keeping the vehicle within the lane.
- Observe the system limitations ⇒ [Lane Assist system limitations](#).
- Always adapt your speed and distance to vehicles driving ahead based on the visual, weather, road, and traffic conditions.
- Always keep your hands on the steering wheel so that you are prepared to steer at any time.
- Override immediately by steering if the system intervenes when it should not.
- Pay attention to indicators in the instrument cluster display and respond to the prompts accordingly when the traffic situation allows.

Lane Assist system limitations

 Please read the introductory information and heed the Warnings and Notice ⇒  [Introduction](#).

Limits of the sensor system

Lane Assist detects lane markings with the camera behind the windshield.

 Observe the limits of the camera ⇒ [Limits of the sensor system](#). Always be attentive and intervene yourself if necessary!

Lane markings not detected or not correctly recognized

Lane Assist does not correctly detect all lane markings. If lane markings are not detected or if markings are incorrectly detected as lane markings, Lane Assist may fail to intervene when it should or may intervene when not desired. In addition to the situations specified in the camera limitations, this may also occur in the following situations, among others:

- If lane markings are not present.
- When the driving style is very dynamic.
- When not on highways or well-developed roads.
- On poor road surfaces, road structures or objects.
- In the event of reflections or dazzling effects.

Always be attentive and intervene yourself if necessary by overriding unwanted interventions by the system immediately. Temporarily switch off Lane Assist if required.

Lane Assist not ready to take control

Lane Assist is not ready to take control (system status inactive) under the following conditions:

- The vehicle speed is less than around 55 km/h (around 30 mph).
- Lane Assist has not detected a lane marking.
- If lanes and curves are too narrow.
- Temporarily, when the driving style is very dynamic.

- When the turn signals are switched on before a manual lane change.
- When the driver oversteers during a system intervention.
- When there is no reaction from the driver to a driver intervention prompt.

Driving with Lane Assist



📖 Please read the introductory information and heed the Warnings and Notice ⇒ ⚠️ *Introduction*.

Switching on and off

You can view the current condition of Lane Assist on the instrument cluster display and in the Infotainment system. You can also switch Lane Assist on and off there.

In the instrument cluster display:

1. Press the  button.
2. Switch Lane Assist on or off.

 Depending on the vehicle equipment, the  button is located either on the multi-function steering wheel or the turn signal and high beam lever.

In the Infotainment system:

1. Open the Assistance systems menu.
2. Switch Lane Assist on or off in the corresponding submenu.

 If there is a system malfunction, Lane Assist may turn off automatically.

Displays

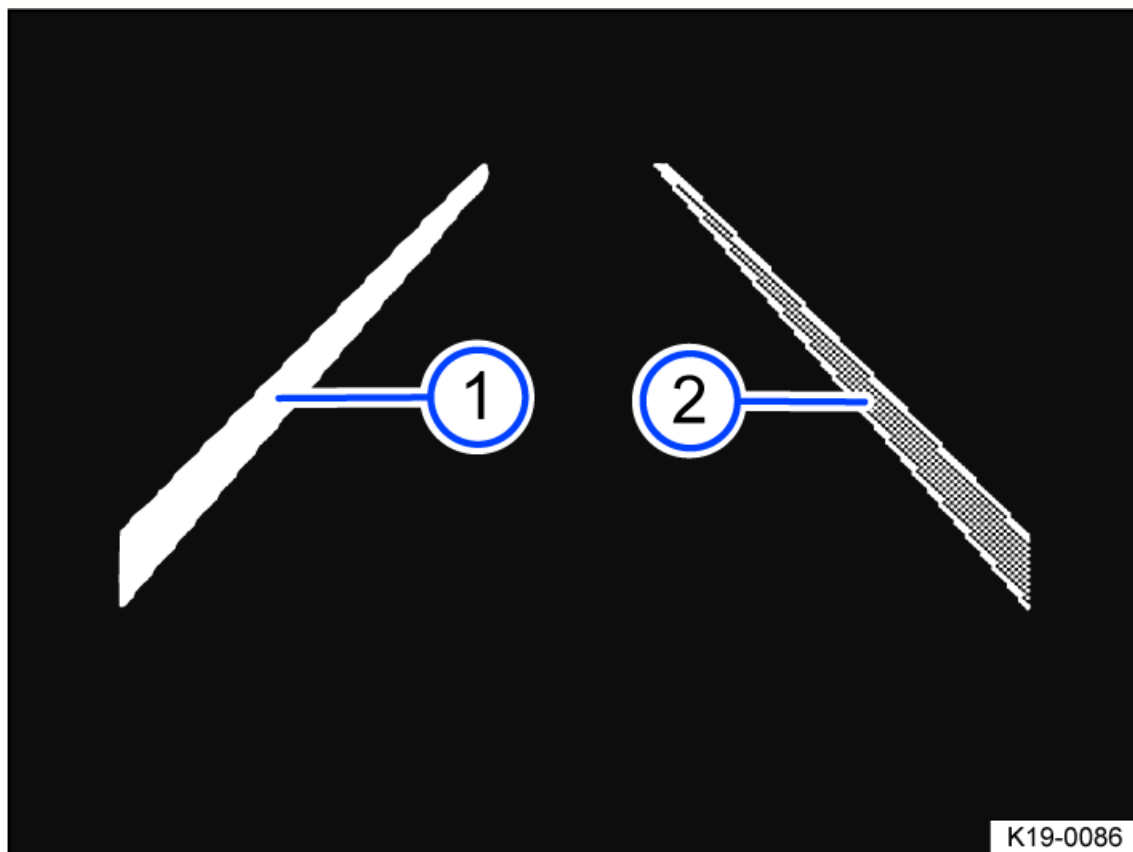

Fig. 107 In the instrument cluster display: Lane Assist displays.

- ① Lane marking detected. The system is monitoring on the indicated side.
- ② Lane marking detected. The system is ready to monitor on the indicated side.

Depending on the vehicle equipment, further details about lane marking, such as broken road markings, may also be shown on the instrument cluster display.

Depending on the equipment, a display may also appear in the head-up display.

Depending on the driving situation, one of the following indicator lights will light up in the instrument cluster:

 System active and ready to control.  System in operation (corrective steering intervention).

If the indicator light does not light up, Lane Assist is not ready for operation on both sides (inactive system status) or is switched off.

 If Travel Assist is actively controlling, there will not be any steering intervention and no Lane Assist display.

Driver intervention request

If there is no steering activity, Lane Assist will prompt you to drive in the center of your lane with an indicator in the instrument cluster display and warning chimes.

If you do not respond accordingly, Lane Assist will become inactive.

Depending on the vehicle equipment, Semi-automated vehicle assistance in a medical emergency (Emergency Assist) is activated when Emergency Assist is switched on in the Infotainment system.

Independently of steering activity, you are also prompted by an indicator on the instrument cluster display and by a warning chime to drive in the middle of the lane if the corrective steering intervention takes a long time.

Steering wheel vibration

The following situation may cause the steering wheel to vibrate:

- A lane is no longer detected during a sharp corrective steering intervention by the system.

In addition, you can select the Vibration or Steering wheel vibration option in the Assistance systems menu in the Infotainment system. If you select this option, the steering wheel will vibrate if Lane Assist is active and you drift onto a road lane marking that the system has detected.

Troubleshooting

 Please read the introductory information and heed the Warnings and Notice ⇒  [Introduction](#).

Lane Assist not available

The yellow indicator light turns on. In addition, a message is shown in the instrument cluster display.

- The camera field of view is dirty. Clean the windshield ⇒ [Vehicle care](#).
- The camera's view is limited due to weather conditions, such as snow, or from soap residue or coatings. Clean the windshield ⇒ [Vehicle care](#).
- The camera's view is limited by attachments or stickers. Keep the area around the camera field of view clear ⇒ [Sensor and Cameras](#).
- The camera is misaligned or damaged, for example as a result of damage to the windshield. Check if there is noticeable damage ⇒ [Sensors and Cameras](#).
- The camera was automatically deactivated due to a high ambient temperature or long exposure to direct sunlight. Lane Assist will be available once the camera is available again. Stop the engine and restart.
- Malfunction or fault. Stop the engine and restart.
- If the problem persists, contact an authorized Volkswagen dealer or authorized Volkswagen Service Facility. Volkswagen recommends contacting an authorized Volkswagen dealer or authorized Volkswagen Service Facility.

 It can take a few seconds once the ignition has been switched on for a system fault to be recognized.

 If Lane Assist is not available, Emergency Assist is not available either.

 If Lane Assist is not available, Travel Assist is not available either.

The system is functioning differently than expected

1. Do not mount any objects on the steering wheel.

Controls are responding differently than expected

Moisture, dirt and grease may limit the functioning of the controls.

1. Always keep the control panels clean and dry.

Comfort drive Travel Assist

Introduction

Thanks to the comfort drive Travel Assist, within the system limitations, the vehicle can maintain a distance, which has been preselected by the driver, to the vehicle in front and hold the preferred position within the lane (adaptive lane guidance).

Does this vehicle have Travel Assist?

The vehicle has Travel Assist, if the  button on the multi-function steering wheel is available.

Speed range

You can set a speed of between 20 km/h (15 mph) and 210 km/h (130 mph). This speed range may vary depending on the country.

Travel Assist system limitations

Travel Assist detects driving situations using the same sensor technology as the Adaptive Cruise Control (ACC) and Lane Keeping System (Lane Assist).

 Note the system limitations and information regarding ACC and Lane Assist. Always pay attention and intervene yourself if necessary!

Driving with Travel Assist

Travel Assist automatically regulates the speed and steers the vehicle. Within the system limitations, Travel Assist can also bring the vehicle to a halt behind a stopping vehicle and drive on again.

You can override the Travel Assist regulation function at any time.

Displays

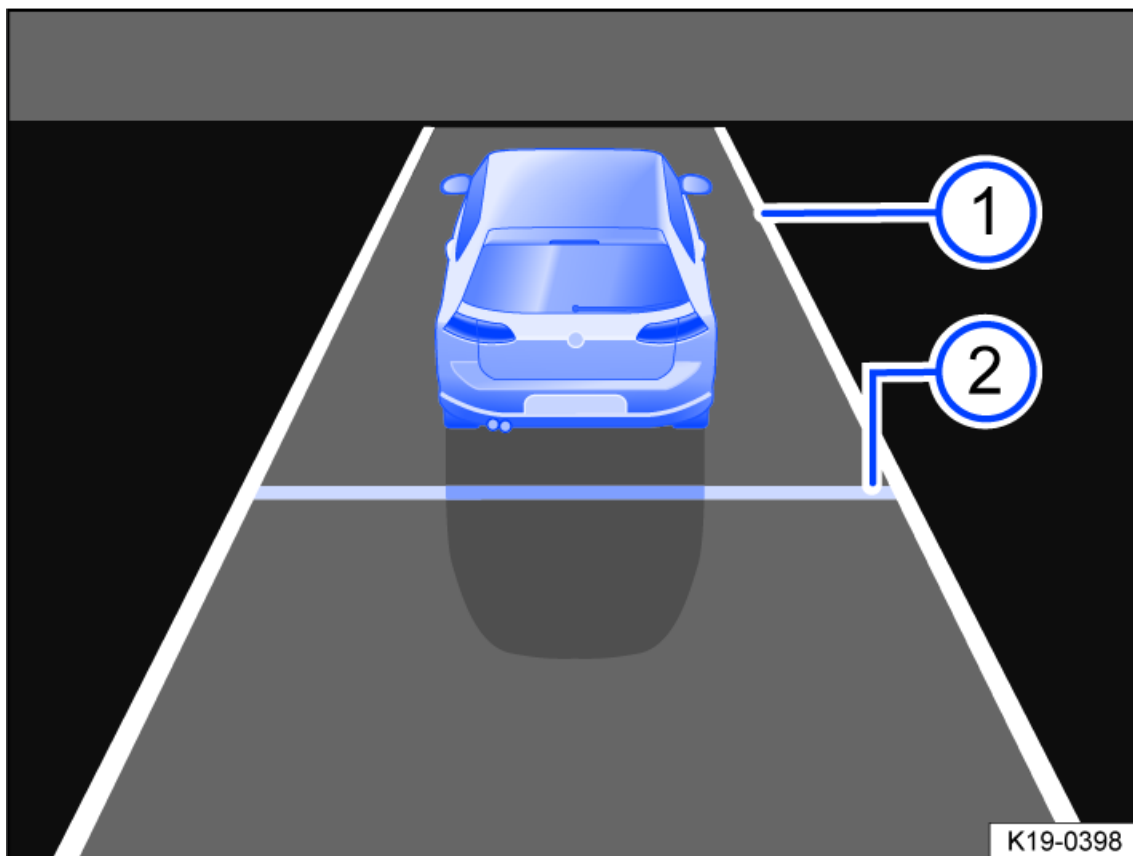



Fig. 108 In the instrument cluster display: Display during active control.

- ① Adaptive lane guidance is active.
- ② Set distance.

Depending on the equipment, a display may also appear in the head-up display.

Depending on the vehicle equipment, further details may also be shown on the instrument cluster display, such as broken road markings and vehicles driving in front.

Indicator lights on the instrument cluster display show the Travel Assist status, depending on the vehicle equipment:

 Travel Assist active, Adaptive Cruise Control and adaptive lane guidance active.  Travel Assist inactive, Adaptive Cruise Control (ACC) active and adaptive lane guidance inactive.

Driver intervention request

If you remove your hands from the steering wheel, the system will ask you to take over the steering wheel after a few seconds with a message in the instrument cluster display and with audible warnings.

If you do not respond to this, Travel Assist is deactivated.

Alternatively, Emergency Assist is activated if Emergency Assist is switched on and available in the Infotainment system, depending on the vehicle equipment.

WARNING

Travel Assist is not a replacement for the driver's attention and works only within the system limitations. Travel Assist cannot detect all driving situations and may not react, may react with a delay, or may react in a way that is not desired. If you are careless, there is a risk of accidents, serious injuries and death.

- Always stay attentive and do not rely solely on the system. The driver is always responsible for control of the vehicle.
- Note the system limitations of ACC ⇒ *ACC system limitations* and Lane Assist ⇒ *Lane Assist system limitations*.

- Always adapt your speed and distance to vehicles driving ahead based on the visual, weather, road, and traffic conditions.
- Always keep your hands on the steering wheel so that you are prepared to steer at any time.
- Take over steering immediately if a driver intervention prompt appears in the instrument cluster display or the deceleration by Travel Assist is not sufficient.
- Apply the brakes if the vehicle continues to roll unintentionally, e.g. after a driver intervention prompt.

Operating Travel Assist

📖 Please read the introductory information and heed the Warnings and Notice ⇒ ⚠️ [Introduction](#).



Fig. 109 Left side of the multi-function steering wheel.

Switching on and starting the regulation function

1. During forward travel with ACC switched on, press the  button on the multi-function steering wheel.

The vehicle switches from ACC to Travel Assist.

Depending on the driving situation, the vehicle switches to the following system status in Travel Assist:

- If ACC is regulating, Travel Assist maintains the current speed and the preset distance from the vehicle driving ahead (system status inactive).
At the same time, the vehicle is kept in its lane by steering movements when road markings are detected (system status active).
- If ACC is not regulating, Travel Assist is switched on, but stays deactivated.

1. Press the **SET** button.

Travel Assist switches the driving situation accordingly to an active or inactive system status.

The indicator/warning light corresponding to the driving situation comes on in the instrument cluster display.

Canceling the regulation function

1. Press the  button briefly.

Or: Press the brake pedal.

The set distance remains saved.

Changing to ACC



1. Press the  button on the multi-function steering wheel.

The vehicle switches from Travel Assist to the system status of ACC corresponding to the driving situation.

Adjusting further settings

The further operation of Travel Assist corresponds to the operation of the ACC ⇒ [Adjusting the ACC settings](#).

Troubleshooting

 Please read the introductory information and heed the Warnings and Notice ⇒  [Introduction](#).

Comfort drive Travel Assist is not available or is not working as expected

The yellow indicator light turns on. In addition, a message is shown in the instrument cluster display.

- There is a malfunction in the sensor system. Check the causes and troubleshooting measures described in the information on ACC and Lane Assist.
- Malfunction or fault. Stop the engine and restart.
- The system limitations are not adhered to.
- If the problem persists, contact an authorized Volkswagen dealer or authorized Volkswagen Service Facility. Volkswagen recommends contacting an authorized Volkswagen dealer or authorized Volkswagen Service Facility.

Take over the steering

The white indicator light will come on and a message will be shown on the instrument cluster display.

You have let go of the steering wheel for a few seconds.

1. Take hold of the steering wheel and take over steering the vehicle.

Take over the steering immediately

The red warning light will come on and a message will be shown in the instrument cluster display. An audible warning will sound or the steering wheel will vibrate, depending on the driving situation.

You have let go of the steering wheel for a long period of time or the system limits have been reached.

1. Immediately take hold of the steering wheel and take over steering the vehicle.

Comfort drive Travel Assist switches off automatically

- Vehicles without Emergency Assist:
 - You have let go of the steering wheel for a long period of time.
- Malfunction or fault. Stop the engine and restart.
- If the problem persists, contact an authorized Volkswagen dealer or authorized Volkswagen Service Facility. Volkswagen recommends contacting an authorized Volkswagen dealer or authorized Volkswagen Service Facility.

The regulation function is canceled unexpectedly

- You have operated the turn signal.

Semi-automatic vehicle control in a medical emergency (Emergency Assist)

Introduction

Emergency Assist can recognize driver inactivity and can automatically keep the vehicle in its lane and, if necessary, slow it down to a stop. The system can hereby actively help to avoid an accident or reduce the consequences of an accident.

Emergency Assist system limitations



Emergency Assist detects driving situations using the same sensor technology as the Adaptive Cruise Control (ACC) and Lane Keeping System (Lane Assist).

WARNING

Emergency Assist is not a replacement for the driver's attention and works only within the system limitations. Emergency Assist cannot detect all driving situations and may not react, may react with a delay, or may react in a way that is not desired. Emergency Assist also cannot always avoid accidents and serious injury by itself. If you are careless, there is a risk of accidents, serious injuries and death.

- Always stay attentive and do not rely solely on the system. The driver is always responsible for control of the vehicle.
- Observe the system limitations of ACC ⇒ [ACC system limitations](#) and Lane Assist ⇒ [Lane Assist system limitations](#).
- Always adapt your speed and distance to vehicles driving ahead based on the visual, weather, road, and traffic conditions.
- If the vehicle behaves unexpectedly, stop the intervention by Emergency Assist.

Driving with Emergency Assist

 Please read the introductory information and heed the Warnings and Notice ⇒  [Introduction](#).

Switching on and off

You can switch Emergency Assist on and off in the Assistance systems menu in the Infotainment system.

When it is switched on, Emergency Assist is only active under the following conditions:

- Travel Assist or Lane Assist is switched on.
- The system must detect lane markers on the left and right side of the vehicle.

 If there is a system malfunction, Emergency Assist may switch off automatically.

 If Lane Assist is not available, Emergency Assist is not available either.

Driver intervention request

Using warning chimes and brief braking maneuver, Emergency Assist prompts an inactive driver to take over control of driving. In addition, a message is shown in the instrument cluster display and the volume of the Infotainment system is decreased.

System intervention

If you do not respond, the system can brake the vehicle and keep it in its lane. The following indicator light will come on in the instrument cluster display:

 System is regulating.

You can cancel the regulation at any time by accelerating rapidly, braking or steering as the traffic situation allows.

If Emergency Assist is active, other road users will be warned as follows:



- The emergency flashers are switched on after a short delay.
- The vehicle's horn sounds, depending on the speed.

If the remaining stopping distance is sufficient, the vehicle slows down, if necessary, to a stop.

As soon as the vehicle comes to a standstill, the following happens:

- The electronic parking brake is switched on.
- Gear **P** is engaged.
- The doors are unlocked.
- The interior lighting is switched on.
- Depending on the vehicle equipment, an emergency call is made.

Troubleshooting

 Please read the introductory information and heed the Warnings and Notice ⇒  [Introduction](#).

 Semi-automated vehicle assistance in a medical emergency (Emergency Assist) not available

Malfunction or fault. The yellow indicator light turns on. In addition, a message is shown in the instrument cluster display.

1. Stop the engine and restart.
2. If the problem persists, turn off Emergency Assist and contact suitably qualified professionals. Volkswagen recommends contacting an authorized Volkswagen dealer or authorized Volkswagen Service Facility.

The system is triggered unwantedly or is functioning differently than expected

Malfunction or fault.

- Switch off the Lane Keeping System (Lane Assist).
- Do not use semi-automated driving assistance (Travel Assist).
- Contact suitably qualified professionals to have the system checked. Volkswagen recommends contacting an authorized Volkswagen dealer or authorized Volkswagen Service Facility.

Controls are responding differently than expected

Moisture, dirt and grease may limit the functioning of the controls.

1. Always keep the control panels clean and dry.

Lane Change System (Side Assist)

Introduction

The Lane Change System (Side Assist) helps the driver to discern the traffic situation behind the vehicle.

Radar sensors behind the rear bumper cover monitor the area behind the vehicle. The system measures the distance and difference in speed to other vehicles and informs the driver through visual signals in the outside mirrors.

Only use Side Assist on secure roads.

Speed range



If Side Assist is switched on, this function is available from approx. 15 km/h (approx. 9 mph). Side Assist is deactivated at speeds below approx. 10 km/h (approx. 6 mph).

WARNING

Side Assist is not a replacement for the driver's attention and works only within the system limitations. Side Assist cannot detect all driving situations and all objects in the surrounding environment, and may not provide warnings, may provide warnings with a delay, or may provide warnings in a way that is not desired. If you are careless, there is a risk of accidents, serious injuries and death.

- Always stay attentive and do not rely solely on the system. The driver is always responsible for control of the vehicle and changing lanes.
- Observe the system limitations ⇒ [Side Assist system limitations](#).
- Always adapt your speed and distance to vehicles driving ahead based on the visual, weather, road, and traffic conditions.
- Always keep your hands on the steering wheel so that you are prepared to steer at any time.
- Pay attention to the displays in the outside mirror housings and in the instrument cluster display, and act accordingly.

Side Assist system limitations

 Please read the introductory information and heed the Warnings and Notice ⇒  [Introduction](#).

Limits of the sensor system

Side Assist detects driving situations via the radar sensors in the rear area.

 Note the limits of the radar sensors ⇒ [Limits of the sensor system](#) and always pay attention!

Functional limitations

In addition to the situations specified in the sensor system limitations, Side Assist may not correctly interpret the traffic situation in the following situations, among others:

- When driving in the center of two lanes.
- When lanes have different widths.
- When certain types of equipment are on the side of the road, such as high or offset guard rails.

The Lane Change System (Side Assist) does not detect any stationary vehicles either.



Restricted visibility

Sunlight may reduce the visibility of the visual display in the outside mirror.

Calibration

After the delivery of the vehicle, the radar sensors are calibrated within the first kilometers driven. This happens only once, and then again if the sensor technology has been repaired. The range of the sensors may be limited during the calibration phase.

Driving with Side Assist



 Please read the introductory information and heed the Warnings and Notice ⇒  [Introduction](#).

Switching on and off

You can view the current condition of Side Assist on the instrument cluster display and in the Infotainment system. You can also switch Side Assist on and off there.

In the instrument cluster display:

1. Press the  button.
2. Switch Side Assist on or off.

 Depending on the vehicle equipment, the  button is located either on the multi-function steering wheel or the turn signal and high beam lever.

In the Infotainment system:

1. Open the Assistance systems menu.
2. Switch Side Assist on or off in the corresponding submenu.

When it is switched on, the yellow indicator light  in the outside mirrors comes on once briefly.

Deactivation due to trailer mode

If you use the trailer hitch installed at the factory and have made the required electrical connection, Side Assist will switch off automatically. Once a trailer is connected to the vehicle electrical system and the driver starts to drive, a message will appear in the instrument cluster display stating that Side Assist is deactivated. Once you have disconnected the electrical connection Side Assist will be automatically switched on again.

For trailer hitches that were not installed at the factory, you must switch Side Assist off and on again manually.

Displays in the outside mirror



Fig. 110 In the mirror glass of the outside mirrors: indicator of Side Assist.

 Blinking: a vehicle in the blind spot has been detected and the turn signal is also activated towards the detected vehicle.

 Lights up: the vehicle you are driving is being overtaken or you are overtaking another vehicle with a difference in speed of up to approx. 15 km/h (approx. 9 mph).

There is no indicator if the passing speed is clearly faster.

The faster another vehicle approaches, the sooner the display in the outside mirror will turn on.

Lane change system “Side Assist Plus”

In vehicle with a Lane Keeping System (Lane Assist), a corrective steering intervention warns you when a possible critical situation is detected when changing lanes (information level, warning level), if Lane Assist is switched on. The steering intervention also occurs if you activate the turn signal for the respective side. If you oversteer the steering intervention, an additional warning is provided by a steering wheel vibration. Steering wheel vibration must also be activated in the Assistance systems menu in the Infotainment system.

Brightness

The brightness of the visual display adapts it self automatically to the ambient brightness.

You can set the default brightness of the display in the Assistance systems menu of the Infotainment system. Side Assist is not active while adjusting the settings.

Troubleshooting

 Please read the introductory information and heed the Warnings and Notice ⇒  [Introduction](#).

Side Assist malfunction

Malfunction or fault. The yellow indicator light in the instrument cluster display lights up. In addition, the yellow central warning light  comes on.

1. Stop the engine and restart.
2. If the problem persists, contact an authorized Volkswagen dealer or authorized Volkswagen Service Facility. Volkswagen recommends contacting an authorized Volkswagen dealer or authorized Volkswagen Service Facility.

Malfunctioning sensor view, malfunction message, system switches off automatically

- Clean the radar sensors and remove stickers or attachments from the radar sensors or the bumper ⇒ [Exterior care and cleaning](#), ⇒ [Sensors and Cameras](#).
- Check if there is any noticeable damage ⇒ [Sensors and Cameras](#).
- If the problem persists, contact an authorized Volkswagen dealer or authorized Volkswagen Service Facility. Volkswagen recommends contacting an authorized Volkswagen dealer or authorized Volkswagen Service Facility.

The system is functioning differently than expected

- The radar sensors could be dirty. Clean the radar sensors ⇒ [Exterior care and cleaning](#).
- The radar sensors could be covered by water.
- The view of the radar sensors is limited due to weather conditions, such as snow, or due to dirt, soap residue or coatings. Clean the radar sensors ⇒ [Exterior care and cleaning](#).
- The system limitations are not adhered to ⇒ [Side Assist system limitations](#).
- The vehicle could be damaged in the radar sensor area, for example from parking barriers. Check if there is any noticeable damage ⇒ [Sensors and Cameras](#).
- The view of the radar sensors is limited by attachments, bicycle rack systems or stickers. Clear the area around the field of view of the radar sensor ⇒ [Sensors and Cameras](#).
- Painting work was carried out on or structural modifications were made to the area around the radar sensors, to the rear of the vehicle or to the suspension ⇒ [Repairs and technical modifications](#).
- The side mirrors have been covered with after-market tinting films ⇒ [Repairs and technical modifications](#).
- If the problem persists, contact an authorized Volkswagen dealer or authorized Volkswagen Service Facility. Volkswagen recommends contacting an authorized Volkswagen dealer or authorized Volkswagen Service Facility.

Controls are responding differently than expected

Moisture, dirt and grease may limit the functioning of the controls.

1. Always keep the control panels clean and dry.

Parking and maneuvering

Parking the vehicle

Parking

1. Press and hold the brake pedal.
2. In vehicles with an automatic transmission, move the selector lever into the **P** position (parking lock).
3. Set the electronic parking brake.
4. On uphill and downhill slopes, turn the steering wheel so that the vehicle will roll into a curb if it begins moving.
5. Stop the engine and switch the ignition off.

The red **PARK** indicator light in the instrument cluster display will turn on ⇒ .

6. Release the brake.
7. Exit the vehicle ⇒ . Pay attention to other road users.
8. Take all vehicle keys with you and lock the vehicle.

WARNING

Parking the vehicle incorrectly can result in the vehicle rolling, even on slight downhill slopes. Accidents and serious or fatal injuries could result.

- Before exiting the vehicle, make sure the electronic parking brake is activated and the red warning light **PARK** comes on in the Volkswagen Digital Cockpit display once the ignition has been switched off.
- When parking the vehicle, always follow the steps in the specified order.

WARNING

If you leave children, people requiring assistance or animals unattended in the vehicle, they may accidentally set the vehicle in motion or be subjected to very high or low temperatures. There is a risk of accidents and serious or fatal injuries.

- Never leave children, people requiring assistance or animals unattended in the vehicle.

Parking spaces and surroundings

To avoid damage and dangerous situations, always park the vehicle in a suitable parking area ⇒ .

NOTICE

The vehicle can slip on uneven, loose, slippery or icy surfaces and may not be able to be safely held despite the electronic parking brake being switched on. This can result in damage to the vehicle.

- Always park the vehicle on level and suitable ground.

NOTICE

Vehicle components that are low to the ground, such as the bumpers, spoilers, and parts of the suspension, may collide with objects protruding up from the ground when they are driven over. The vehicle can be damaged.

- Drive carefully over driveways, ramps, curbs and fixed barriers, as well as when driving through dips.

Rear seat reminder

The function depends on the vehicle equipment.

If the ignition is switched off, a message appears in the Infotainment system to remind you not to leave behind passengers in the rear seats ⇒ .

If a rear door was used prior to driving, a message will also be displayed in the instrument cluster and a warning tone will sound if necessary. The warning tone can be activated and deactivated in the vehicle settings in the Infotainment system.

 Rear seat reminder muted.

Electronic parking brake

The electronic parking brake secures the parked vehicle to prevent it rolling away. It can be used to brake the vehicle in an emergency.



Fig. 111 In the center console: button for the electronic parking brake.

Switching on

1. When the vehicle is stationary, pull and hold the  button for the electronic parking brake *fig. 111*.

PARK If the electronic parking brake is switched on, the red indicator light comes on in the instrument cluster.

The yellow indicator light in the  button comes on *fig. 111*.

Switching off

1. Switch the ignition on.
2. Press the brake pedal and press the  button.

The indicator light in the  *fig. 111* button and the red **PARK** warning light in the instrument cluster will turn off.

Automatic switch-on if you leave the vehicle incorrectly

On vehicles with an automatic transmission, if the system detects that the vehicle has been exited improperly, it can switch or the electronic parking brake automatically ⇒ .

WARNING

Parking the vehicle incorrectly can result in the vehicle rolling, even on slight downhill slopes. Accidents and serious or fatal injuries could result.

- When parking the vehicle, always follow the steps of the parking procedure in the specified order ⇒ *Parking*.
- Before exiting the vehicle, make sure the electronic parking brake is activated and the red **PARK** warning light in the Volkswagen Digital Cockpit display comes on after switching off the ignition.

Automatic switch-off when starting to drive

If a gear is engaged when the driver door is closed and the accelerator pedal is pressed, the electronic parking brake will switch off automatically ⇒ .

WARNING



If the accelerator pedal is accidentally pressed when the electronic parking brake is activated, this may release the electronic parking brake. The vehicle will start moving. Accidents and serious injuries could result.

- Do not press the accelerator pedal when the engine is running and a gear is engaged if the vehicle is to remain stationary.

Starting on slopes with an increased vehicle weight

If a higher engine output is required when driving off on a slope, the electronic parking brake can be automatically deactivated for a maximum of up to 30 seconds by pulling the  button.

This can make it easier to start driving when towing a heavy load.

1. Engage a selector lever position or gear.
2. Pull the  switch.
3. Press the accelerator pedal.
4. If there is sufficient engine power, release the  button.

The electronic parking brake is disengaged.

Holding force on large gradients

If the gradient of the parking area is too large, the vehicle may not be permanently held.

PARK The indicator light in the instrument cluster display flashes red and a message is displayed.

1. Park the vehicle in a different parking space with a lower gradient.

The vehicle is not held securely in place until the **PARK** indicator light stays on.

Driving through a car wash

If you would not like the electronic parking brake to switch on automatically, e.g. in a car wash, note the following:

1. Automatic transmission: Put the vehicle in neutral **N**.

Emergency braking function

Only use the emergency braking function in an emergency, if the vehicle cannot be stopped using the brake pedal ⇒ .

1. Pull and hold the  switch.

The vehicle will brake abruptly. A warning chime will also sound at the same time.

WARNING

The electronic parking brake is not designed for braking the vehicle, as doing so increases the braking distance. This could result in accidents and serious or fatal injuries.

- Always use the brake pedal to brake the vehicle and never the electronic parking brake unless it is an emergency.

 Noises can be heard when you switch the electronic parking brake on or off. This may also occur during an automatic check.

Troubleshooting

BRAKE Electronic parking brake malfunction

The red **BRAKE** warning light comes on. A message is displayed.

There is a system malfunction. The electronic parking brake is not fully closed.

 **Do not continue driving!**

1. Switch the ignition off and back on again.
2. Pull the  button again.

If the red **PARK** warning light comes on in the instrument cluster without an additional warning light, the vehicle is safely parked.

3. If the **BRAKE** warning light continues to stay on, park the vehicle on as level a surface as possible and secure it against rolling away by engaging the parking lock **P**.
4. Contact an authorized Volkswagen dealer or authorized Volkswagen Service Facility for assistance.

/ Electronic parking brake malfunction

The yellow central warning light comes on. The  symbol with a message is additionally shown in the instrument cluster display.

There is a system malfunction.

1. Contact a suitably qualified professional. Volkswagen recommends contacting an authorized Volkswagen dealer or authorized Volkswagen Service Facility.

The electronic parking brake does not switch off

- The requirements for switching off the electronic parking brake are not met ⇒ *Electronic parking brake*.
- The 12 V vehicle battery is drained ⇒ *Start the engine*.

Exit warning system

The exit warning system gives a warning when opening doors if other road users are approaching from behind.



Fig. 112 In the outside mirror glass: exit warning system indicator (general example).

Radar sensors behind the rear bumper cover monitor the area behind the vehicle.

🔊 If, for example, cyclists are approaching the vehicle, the yellow indicator light in the outside mirror glass blinks. A warning signal will also sound at the same time ⇒ ⚠️.

⚠️ WARNING

The exit warning system is not a replacement for the driver's attention and works only within the system limitations. The indicator may not light up or may not light up in time in response to stationary, slow-moving or rapidly approaching objects. If you do not take care, there is a risk of accidents and serious injuries.

- Always stay attentive and do not rely solely on the system. The driver is always responsible for control of the vehicle.
- When opening the doors, pay attention to the vehicle environment, e.g. pedestrians and cyclists.

Requirements

- ✓ Vehicle is stationary.
- ✓ The function has been activated in the Infotainment system.

The exit warning system is active for about 3 minutes after the door is unlocked and opened for the first time or the ignition has been switched off after driving.

1. To reactivate the function after 3 minutes, switch the ignition back on.

Switching on and off

1. Open the menu for the parking systems in the Infotainment system.
2. Tap the ⚙️ function key.
3. Switch the exit warning system on or off.

Depending on the vehicle equipment, the exit warning system can be activated or deactivated in the vehicle settings.

Depending on the country, the exit warning system always switches on after the ignition is switched on.

Driving with a trailer

The exit warning system is deactivated if a trailer is connected to the electrical system. After disconnecting the trailer connection, the exit warning system will be reactivated after an ignition cycle.

If the trailer hitch was not installed at the factory, the exit warning system must be manually deactivated.

Information about the parking systems

Safety instructions

Sensor and camera boundaries

Various sensors and cameras that detect the vehicle surroundings ultrasonically, by radar waves, and visually are located on and in the vehicle. The various parking systems use different combinations of sensors. All sensors have technical and physical limits ⇒ :

- In some situations, some objects may not be detected, e.g. trailer draw bars, narrow poles, fences, posts, and trees, extremely low or high obstacles, or trunk lids that are opening or already open ⇒ .
- The parking system coverage areas have “blind” spots in their range where they cannot detect people and objects.
- Dirt, ice, or water on the sensors and cameras may be detected as obstacles or prevent the detection of objects in some cases. In addition to dirt and snow, soap residue or other coatings can also impair the sensor range → page , *Exterior care and cleaning*.
- External noises and certain surfaces on objects and clothing can affect the sensor signals. In some situations, people and objects may not be detected or may be detected incorrectly.
- Certain objects, such as small posts or grating, cannot be shown or cannot be adequately shown due to the resolution of the screen and if there is insufficient lighting.
- The cameras only show two-dimensional images on the screen. Due to the lack of depth of field, it may be difficult or impossible to identify protruding objects or recesses in the road.

WARNING

The parking systems cannot replace the driver's attention and can only operate within the limitations of the system. The parking systems cannot detect all driving situations and may not react, or may react with a delay, or may react in a way that is not desired. If you are careless, there is a risk of accidents, serious injuries and death.

- Always stay attentive and do not rely solely on the system. The driver is always responsible for control of the vehicle.
- Always keep an eye on the driving direction and the vehicle surroundings.
- When parking, pay particular attention to small children, animals and objects.
- Do not allow the parking system's display to distract you from the traffic around you.
- Bear in mind that the parking system may not react if the vehicle approaches too quickly and will not issue a warning.
- Always adapt your speed and driving style to the visibility, weather, road and traffic conditions.

NOTICE

When you maneuver in a parking space without a curb, the vehicle may be damaged by obstacles.

- Keep a safe distance of approx. 50 cm (around 20 in) from walls and buildings.

 Volkswagen recommends practicing with the parking systems in a location or parking space with no traffic in order to become acquainted with the functions.

Requirements

General information

So that the sensors and cameras can detect the area surrounding the vehicle as well as possible and display this image on the Infotainment system screen, the following requirements must be met.

- ✓ The doors and trunk lid are closed.
- ✓ The outside mirrors must not be folded in.
- ✓ Sensors or cameras are not covered by attachments, e.g. bicycle rack systems, or license plate holders with decorative frames. The decorative license plate holder must not protrude at the sides or bottom.
- ✓ The vehicle must be on level ground.
- ✓ The vehicle must not be loaded primarily in the rear or on one side.
- ✓ Engine is running.
- ✓ Braking assistance systems such as ESC or ASR are switched on.
- ✓ The length and width of the parking space must be larger than the vehicle measurements and provide enough space to maneuver.

 If you use any other functions in the Infotainment system while you are parking, the parking function and its warning chimes will be deactivated.

 The use of parking systems, e.g. with camera assistance, may not be allowed in some countries and regions according to legal provisions.

Automatic braking intervention

The automatic braking function of the parking system helps to avoid collisions once an obstacle is detected.

Parking systems with braking support

Depending on the vehicle equipment, the vehicle has parking systems with a maneuvering and/or emergency braking function ⇒ .

The automatic braking support of Park Distance Control is only possible in the rear area.

WARNING

Automatic braking support is not a replacement for the driver's attention and works only within the system limitations. In some driving situations, the automatic braking support may be limited or may intervene in a way that is not desired or may not engage at all. If you are careless, there is a risk of accidents, serious injuries and death.



- Always stay attentive and do not rely solely on the system. The driver is always responsible for control of the vehicle.
- In a hazardous situation, apply the brakes using the brake pedal before encountering an obstacle.
- React quickly to parking system warnings, e.g. Park Distance Control.

When is automatic braking available?

- ✓ A parking system has been activated by the driver.
- ✓ Park Distance Control: Maneuver braking is activated in the Infotainment system.
- ✓ When maneuvering, the vehicle is not driving faster than approx. 10 km/h (approx. 6 mph).

What happens during an automatic braking intervention?

The vehicle brakes to a stop and is kept stationary for around two seconds.



 Automatic braking by the maneuver braking function. Stop the vehicle with the brake pedal!  Automatic braking intervention by Rear Traffic Alert. Stop the vehicle with the brake pedal!
Depending on the vehicle equipment, a message may be shown in the Infotainment system or on the instrument cluster display.

Park Assist: The vehicle may brake if the speed is too high or in order to reduce damage.

Maneuver braking for Park Distance Control

Maneuver braking brakes only in the event of obstacles in the rear area and is automatically switched on after each time the ignition is switched on.

Maneuver braking can be temporarily deactivated in the Park Distance Control settings in the Infotainment system.

  Maneuver braking deactivated.

 After a braking intervention, maneuver braking may be inactive for a short distance or may only be ready for operation after a gear change. Drive carefully for the first few meters, e.g. in case of further obstacles in the vicinity.

Additional information





 Switch the parking system off temporarily if automatic braking support happens too frequently or when undesired and maneuver the vehicle carefully, for example when driving off-road or parking in your garage.

 The parking process is canceled following Park Assist emergency braking, e.g. if an obstacle has been detected.

 Following a Rear Traffic Alert emergency braking intervention, it will take approx. 10 seconds before automatic braking support can occur again.

Troubleshooting

The parking system is functioning differently than expected

- The requirements for the parking system are not met → page , *Requirements*.
- The sensors or camera may be dirty or covered with ice → page , *Exterior care and cleaning* , ⇒ .
- Sources of noise interfere with the ultrasonic signal, e.g. driving over cobblestones ⇒ .
- The vehicle may be damaged in the radar sensor area, for example, due to parking barriers or an accident ⇒ .
- There may have been changes to the paint or vehicle structure in the area where the sensors or camera are located, for example on the front of the vehicle or the suspension ⇒ .
- The areas detected by the sensors or camera may be blocked by accessories such as bicycle racks.

Fault displays

1. Note any messages in the digital instrument cluster display and in the Infotainment system.

NOTICE

If the parking system is used despite a malfunction of the sensors or cameras or a limitation of the detection ranges, damage to the vehicle may occur.

- Contact an authorized Volkswagen dealer or authorized Volkswagen Service Facility in the event of a parking system malfunction. Volkswagen recommends contacting an authorized Volkswagen dealer or authorized Volkswagen Service Facility.

Parking Function Screen Not Displayed Following Activation

The parking system has been switched on or activated, yet the display in the Infotainment system does not change to the function-specific screen, e.g. segment display for Park Distance Control, camera display during Park Assist.

1. Switch the parking system off and on again.
2. If the screen is still not displayed, a system malfunction has occurred. Contact a suitably qualified professional. Volkswagen recommends contacting an authorized Volkswagen dealer or authorized Volkswagen Service Facility.

Exit warning system or Rear Traffic Alert malfunction

The exit warning system or Rear Traffic Alert has been deactivated. An error message is displayed.

1. Check the sensors on the vehicle for damage or dirt.
2. If the problem persists, contact an authorized Volkswagen dealer or authorized Volkswagen Service Facility. Volkswagen recommends contacting an authorized Volkswagen dealer or authorized Volkswagen Service Facility.

Park Distance Control (PDC)

Introduction

Park Distance Control assists the driver when parking and warns if there are obstacles.

How it works

Using ultrasonic sensors, Park Distance Control detects the distance between the vehicle and an obstacle.

The Park Distance Control warns you of a collision via colored segments on the screen of the Infotainment system and via warning chimes *fig. 113*, ⇒ .

If the driver does not respond to an approaching obstacle, automatic braking support may kick in → page , *Automatic braking intervention*.

WARNING

The Park Distance Control is not a replacement for the driver's attention and works only within the system limitations. Park Distance Control might not be able to detect some obstacles and may not react, may react late, or may react in a way that is undesired. If you do not take care, there is a risk of accidents and serious injuries.

- Always stay attentive and do not rely solely on the system. The driver is always responsible for control of the vehicle.
- React quickly to the Park Distance Control visual warnings and chimes.
- Apply the brakes using the brake pedal before encountering an obstacle.

NOTICE

The system will only provide visual and audible warnings for obstacles within the vehicle's path. The collision area has been reached, at the latest, when the second to last segment is displayed in the Park Distance Control screen or a

continuous warning tone sounds. There is a risk of damage to the vehicle.

- Always brake the vehicle in good time before encountering an obstacle.

! NOTICE

Depending on the vehicle equipment, distances to obstacles in the side areas are also displayed. Any obstacles that enter these areas from the outside are not displayed. The vehicle may be damaged in this instance.

- In order to fully scan and display the side areas, move the vehicle a few meters forwards or backwards.

Screen display

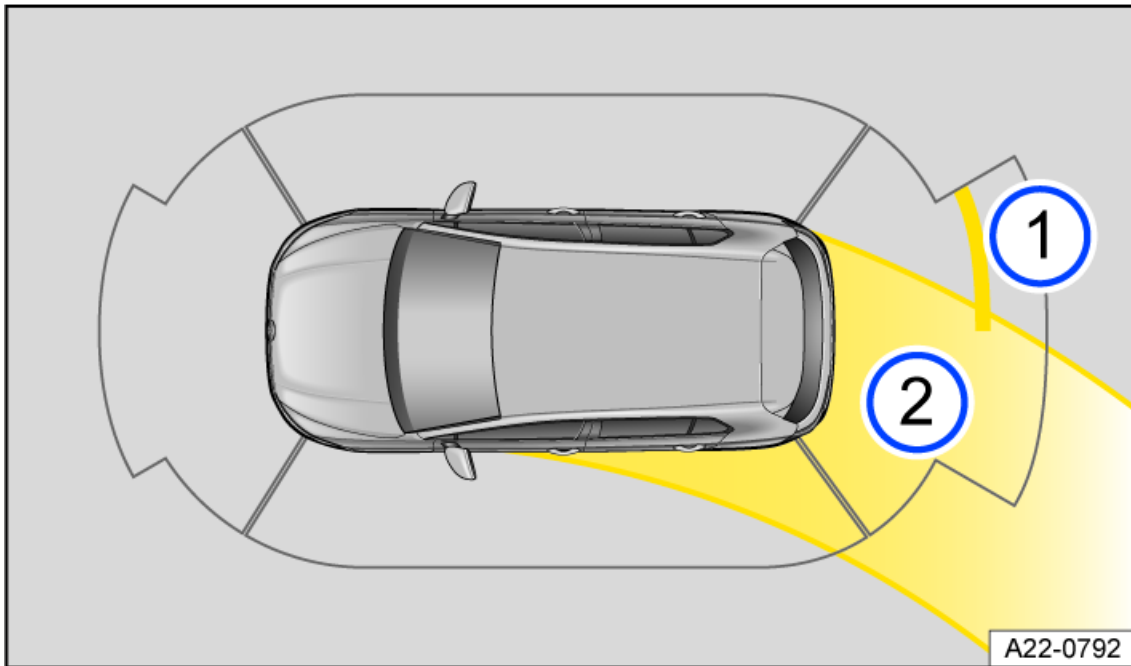



Fig. 113 Infotainment system: Display of Park Distance Control (general example).

① Obstacle display.

② Steering lock.

■ Red section of the image: nearby obstacle. The vehicle is at risk. Brake! ■ Yellow section of the image: obstacle in the path of the vehicle. The vehicle is at risk. Steer around the obstacle. □ Grey section of the image: obstacle outside of the vehicle's path or a malfunction in the sensor area. (A) Δ Maneuver braking deactivated or malfunctioning. 🔇 Δ Mute the warning chimes.

Park Distance Control settings

1. Tap the  control for parking functions in the upper section of the center console.
2. Tap the  function key.
3. Select the setting, e.g. automatic activation when driving forward.

Driving with a trailer

If a trailer electrical system is connected, the rear and side sensors of the Park Distance Control are not switched on:



- You are not warned about obstacles.
- The maneuver braking is also deactivated automatically.

Switching Park Distance Control (PDC) on and off

 Please read the introductory information and heed the Warnings and Notice ⇒  and  *Safety instructions*.

Switching on

1. Select the reverse gear.

Or: tap the  control in the upper section of the center console. Then tap the  function key in the Infotainment system, if necessary.

Or: The vehicle will roll backward.

Switching off

1. Tap the  function key.

Or: tap the  control in the upper section of the center console.



Or: Engage parking lock P.

Park Distance Control also switches off when forward travel becomes faster.

Automatic activation when driving forward

The function can be activated or deactivated in the Park Distance Control settings in the Infotainment system.

Park Distance Control activates automatically in the event of an obstacle in the front area, e.g. in dense traffic or when driving into a garage.

1. To close the Park Distance Control screen, tap the  home button in the Infotainment system or the  control in the upper section of the center console.

 No automatic braking intervention takes place → page , *Automatic braking intervention*.

Automatic activation is available again under following conditions:

- The vehicle has been accelerated to more than approx. 15 km/h (approx. 9 mph) and then the speed has fallen below that again.
Or: the ignition has been switched off and on again.
Or: parking lock **P** has been changed to a gear.

 If an obstacle is detected in front of the vehicle, the Park Distance Control display appears in the Infotainment system. If the vehicle continues to approach the obstacle, a warning chime also sounds.

Troubleshooting

 Please read the introductory information and heed the Warnings and Notice ⇒  and  *Safety instructions*.

No sensor range or Park Distance Control malfunction

If a sensor malfunctions, the sensor area is deactivated. The  symbol shows the affected sensor area in the Infotainment system.

If Park Distance Control is malfunctioning, a continuous tone will sound for several seconds when you switch it on. If necessary, a message will appear in the digital instrument cluster display.

Park Distance Control is switched off completely if necessary.

1. Check if one of the causes listed above is responsible → page , *Troubleshooting*.
2. Once the source of the issue has been resolved, switch the system on again.
3. If the problem persists, contact an authorized Volkswagen dealer or authorized Volkswagen Service Facility. Volkswagen recommends contacting an authorized Volkswagen dealer or authorized Volkswagen Service Facility.

Maneuver braking restricted or not available

A message is displayed.

Automatic braking occurs unexpectedly or does not occur as usual. If the function is switched off, automatic braking does not occur.

1. Check the sensors on the vehicle for damage or dirt and clean them if necessary ⇒ [Exterior care and cleaning](#).
2. Switch the ignition off and back on again.
3. If the problem persists, contact an authorized Volkswagen dealer or authorized Volkswagen Service Facility. Volkswagen recommends contacting an authorized Volkswagen dealer or authorized Volkswagen Service Facility.

Rear View Camera (Rear View)

Introduction

The Rear View Camera system in the rear of the vehicle makes it easier for the driver to see behind the vehicle and assists when parking.

How it works

The Rear View Camera system shows the area behind the vehicle on the Infotainment system screen. Depending on the mode and vehicle equipment, orientation lines may assist in the view toward the rear ⇒ .

WARNING

The Rear View Camera system is not a replacement for the driver's attention and works only within the system limitations. Using the camera image to estimate the distance to people or obstacles may not be precise. If you do not take care, there is a risk of accidents and serious injuries.

- Always stay attentive and do not rely solely on the system. The driver is always responsible for control of the vehicle.
- Bear in mind that camera lenses can enlarge and distort the field of vision.

 The orientation lines superimposed on the camera image are shown by the system regardless of the vehicle's surroundings. There is no automatic obstacle detection by the camera while it is active. The driver must evaluate whether the vehicle will fit in the parking space.

 If a trailer is connected to the factory-installed trailer hitch, all orientation lines for the rear area are hidden in the camera image.



 If a camera is installed in the trunk lid, the orientation lines are also hidden if the trunk lid is open.

Switching the Rear View Camera system on and off



 Please read the introductory information and heed the Warnings and Notice ⇒  and  [Safety instructions](#).

Switching on

1. Select the reverse gear.

Or: tap the  control in the upper section of the center console. If available, then tap the  function key in the Infotainment system.

Switching off







1. Disengage an engaged reverse gear.
2. Tap the  or  function key in the Infotainment system.

The Rear View Camera system also switches off when forward travel becomes faster.

Parking (Rear View Camera system with parking mode selection)

 Please read the introductory information and heed the Warnings and Notice \Rightarrow  and  *Safety instructions*.

Screen display

 Perpendicular parking: Guide lines help when parking in reverse perpendicular to the road.  Cross traffic: Depiction of the area behind the vehicle and the areas to the side of the vehicle at a wide angle.  Red line: Boundary or safety distance from the vehicle.  Yellow lines: the vehicle's path based on the steering angle.  Green horizontal lines: Boundaries.  Adjust the brightness, contrast, and color.

Depending on the country, if the camera image on a parking system has been switched on by engaging the reverse gear, no function keys are displayed for safety reasons. These function keys can be displayed again by tapping the function key .

Parking mode: Parking perpendicular to the road

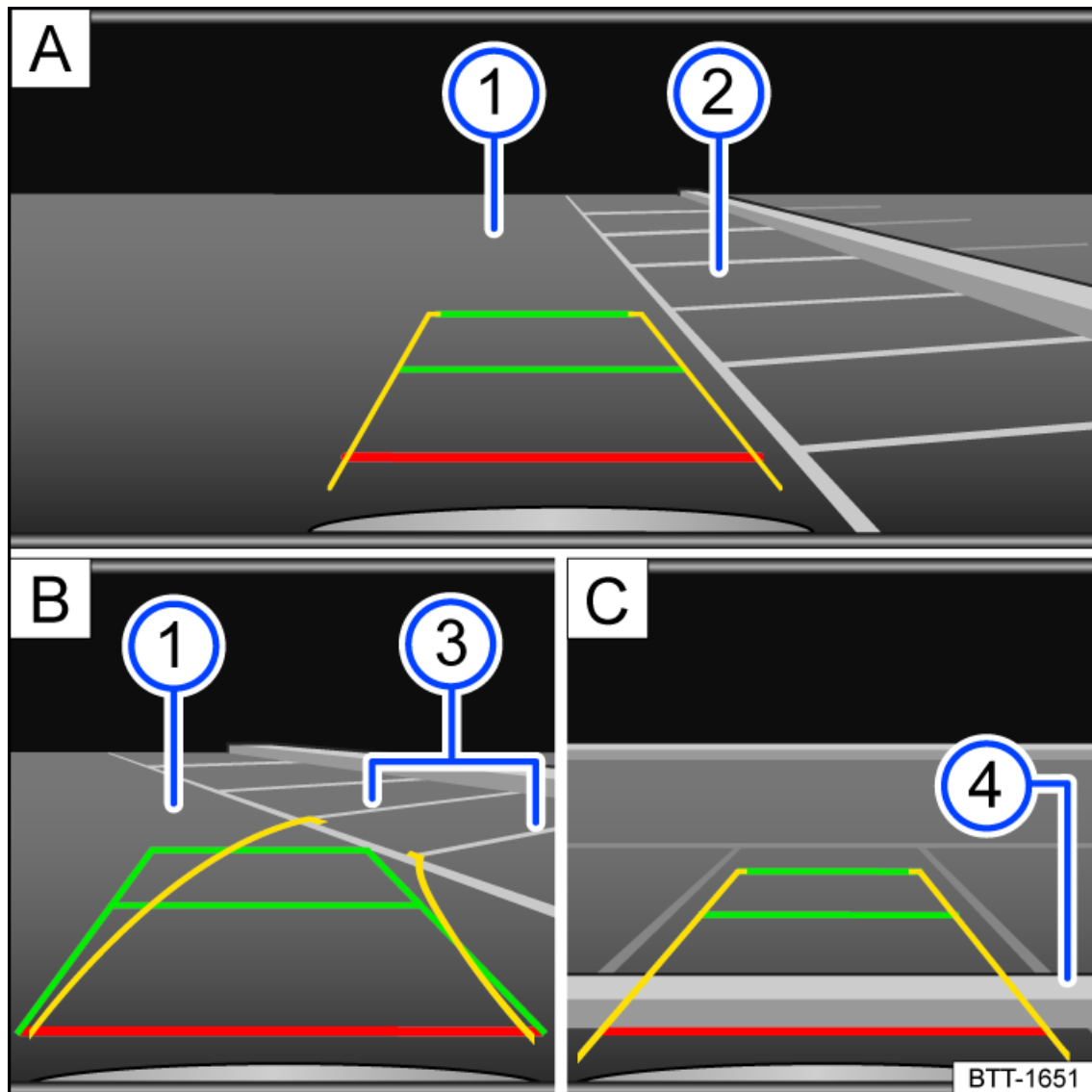



Fig. 114 Infotainment system: Parking perpendicular to the road.

 Searching for a parking space.

B Steering toward the selected parking space.







C Aligning the vehicle within the parking space.

① Road surface.

② Parking space.

③ Side boundary of the parking space.

④ Rear boundary of the parking space.

1. Press the  control panel for parking functions before driving past the selected parking space. Then tap the  function key in the Infotainment system, if necessary.
2. To select the parking mode, tap the  function key in the Infotainment system.
3. Position your vehicle in front of the parking space *fig. 114*  ②.
4. Steer so that the yellow lines lead into the parking space. The green and yellow lines must align with the side boundary lines *fig. 114*  ③.
5. Stop when the red line reaches the rear boundary *fig. 114*  ④.

Troubleshooting

 Please read the introductory information and heed the Warnings and Notice ⇒  and  *Safety instructions*.

Malfunction of Camera Image of the Rear View Camera System

The camera image is unclear, “flickering” or has been disabled.

A technical malfunction may have occurred.

1. In the event of an unclear camera image, clean the Rear View Camera system ⇒ *Exterior care and cleaning*.

Or: check whether the parking system has a malfunction due to external factors → page , *Troubleshooting*.

2. If the problem persists, contact an authorized Volkswagen dealer or authorized Volkswagen Service Facility. Volkswagen recommends contacting an authorized Volkswagen dealer or authorized Volkswagen Service Facility.

Area View

Introduction

The Area View function can display the entire vehicle surroundings in real time.

This function helps you recognize obstacles in good time in situations where there might be blind spots.

How it works

The Area View displays the vehicle surroundings with the aid of multiple cameras, e.g. in the rear area, in the front of the vehicle and in the outside mirrors ⇒ .

WARNING

Area View is not a replacement for the driver's attention and works only within the system limitations. Using the camera image to estimate the distance to people or obstacles may not be precise. If you do not take care, there is a risk of accidents and serious injuries.



- Always stay attentive and do not rely solely on the system. The driver is always responsible for control of the vehicle.

- Bear in mind that camera lenses can enlarge and distort the field of vision.

Switching on and off

📖 Please read the introductory information and heed the Warnings and Notice ⇒ ⚠️ and ⚠️ *Safety instructions*.

Switching on

1. Tap the  control in the upper section of the center console. Then tap the  function key on the Infotainment system screen.

Or: Engage reverse gear.

Switching off

1. Tap the  or  function key in the Infotainment system.

Or: tap the  control for parking functions.

Changing the camera perspective

📖 Please read the introductory information and heed the Warnings and Notice ⇒ ⚠️ and ⚠️ *Safety instructions*.

Sections of the screen

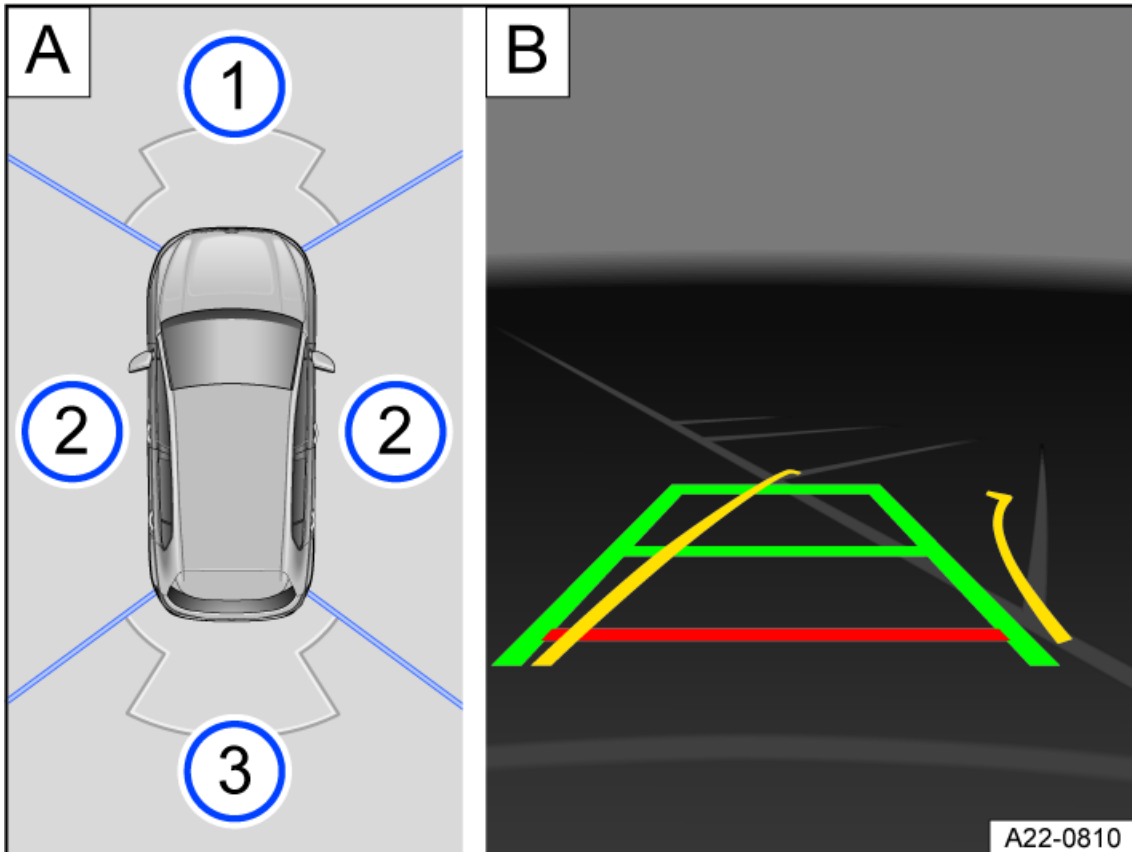

Fig. 115 Infotainment system: Area View with "Perpendicular parking mode" camera image (general example).

A Bird's eye view with selectable sections of the screen.

B Camera image.

- ① Screen area for the front camera image.
- ② Screen area for the camera image of both sides of the vehicle.
- ③ Screen area for the rear camera image.

Two sections of the screen will be shown in the Infotainment system *fig. 115:*

1. To display the preferred camera image on the right [fig. 115 B](#), tap the front, rear or side screen area on the left [fig. 11 A](#).

Change screen display

In the same way as the rear view camera, Area View can display the surrounding area with various screen displays.

1. Tap the function key with the corresponding symbol on the lower edge of the screen.

 Front perpendicular parking.

Guide lines help when parking forwards perpendicular to the road.

 Rear perpendicular parking.

Guide lines help when parking in reverse perpendicular to the road.

 Front cross traffic.

Depiction of the area in front of the vehicle with a wide angle.

 Rear cross traffic.

Depiction of the area behind the vehicle with a wide angle.

Other screen displays

 Red line: Boundary or safety distance from the vehicle.  Yellow lines: the vehicle's path based on the steering angle.

 Green horizontal lines: Boundaries.  Adjust the brightness, contrast, and color.

Troubleshooting

 Please read the introductory information and heed the Warnings and Notice  and  *Safety instructions*.

Take note of the information regarding troubleshooting for the Rear View Camera system → page , *Troubleshooting*.

Park Assist

Introduction

Park Assist displays a suitable parking space and assists the driver when parking and leaving the parking space.

How it works

Park Assist is an extension of Park Distance Control.

Park Assist steers the vehicle into a parking space while the driver operates the accelerator pedal and the brake and, when prompted, changes the selector lever position or gear .

Available functions

- Displaying suitable parking spaces in the Infotainment system.
- Change the parking space selection in the Infotainment system.
- Driving into a suitable parallel parking space or parking bay.
- Driving out of a suitable parallel parking space.

The driver should continuously monitor the area surrounding the vehicle . Automatic braking support may intervene if there are obstacles in the vehicle's path or in dangerous situations → page , *Automatic braking intervention*.

 If the driver accelerates too much during the parking process, automatic braking support may occur. The parking process can then be resumed.

 The speed when driving past the parking space should be as follows: for parking spaces parallel to the road, maximum approx. 40 km/h (approx. 25 mph), and for parking spaces across the road, maximum approx. 20 km/h (approx. 12 mph).

 The distance when driving past the parking space should be between approx 0.5 m (approx 1.6 ft) and approx. 2 m (approx. 6.5 ft).

Driving with a trailer

Park Assist cannot be activated if a trailer is connected to the electrical system.

If the trailer hitch was not installed at the factory, Park Assist must be manually deactivated.

WARNING

Park Assist is not a replacement for the driver's attention and works only within the system limitations. Park Assist cannot detect all driving situations and may not react, may react with a delay, or may react in a way that is not desired. If you are careless, there is a risk of accidents, serious injuries and death.

- Always stay attentive and do not rely solely on the system. The driver is always responsible for control of the vehicle.
- In a hazardous situation, apply the brakes using the brake pedal.

WARNING

If you use another function in the Infotainment system when maneuvering with the parking system, all active parking functions will switch off, including the warning chimes. You will no longer be warned about a collision or receive intervention. Accidents and serious or fatal injuries could result.

- Do not use any other functions in the Infotainment system while maneuvering.

NOTICE

Park Assist orients itself to parked vehicles, curbs, or other objects. If there are obstacles on the ground, low-down vehicle components such as tires and wheel rims may be damaged.

- Watch out for obstacles on the ground when parking.
- Brake and stop the parking process if necessary.

NOTICE

Aftermarket accessories mounted on the vehicle, such as bicycle racks, can interfere with the Park Assist functionality and can cause damage.

- Do not use Park Assist if there are attachments fitted on the vehicle.

Searching for parking spaces

 Please read the introductory information and heed the Warnings and Notice  and  *Safety instructions*.

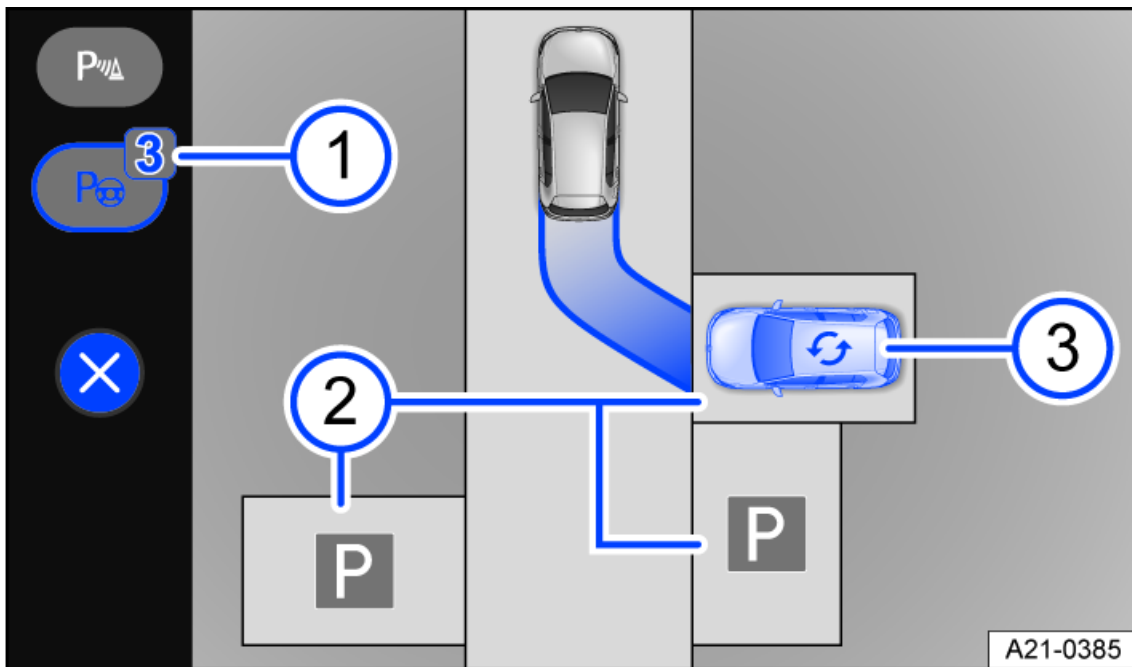



Fig. 116 Infotainment system: selecting a parking space (general example).

- ① Number of parking spaces.
- ② Available parking mode.
- ③ Selected preferred parking space (blue vehicle).
Symbol : load new parking space selection.

Available parking mode

The following parking modes are displayed with the parking spaces arranged horizontally or vertically in the Infotainment system:

- Cross parking driving forward.
- Cross parking in reverse.
- Parallel parking in reverse.

Searching for parking spaces

1. Tap the  control in the upper section of the center console.
2. While paying attention to traffic around your vehicle, drive slowly past a row of parked vehicles.

Park Assist will automatically look for possible parking spaces.

The number of detected parking spaces is displayed on the  function key *fig. 116*.

3. Park Assist Plus selects a preferred parking space and displays a blue vehicle graphic *fig. 116*.
4. Come to a complete stop and press and hold the brake pedal.

Changing parking spaces

If multiple parking spaces have been detected along the road, you can switch to another parking space.

1. Tap the desired parking space on the Infotainment system screen *fig. 116*.

A new preferred parking space (blue vehicle) is displayed.

Changing the parking view

If a new selection of parking spaces can be loaded, the  symbol will be displayed *fig. 116*.

1. Tap the  symbol.

A new parking view with other parking modes is displayed.

 Park Assist can be activated subsequently. If you drive past a suitable parking space and then drive into the parking space, this will be indicated afterwards.

 If Park Assist is not activated, detected parking spaces [fig. 116](#) are shown in the Park Distance Control screen display, if necessary.

Driving into parking spaces

 Please read the introductory information and heed the Warnings and Notice  and  *Safety instructions*.

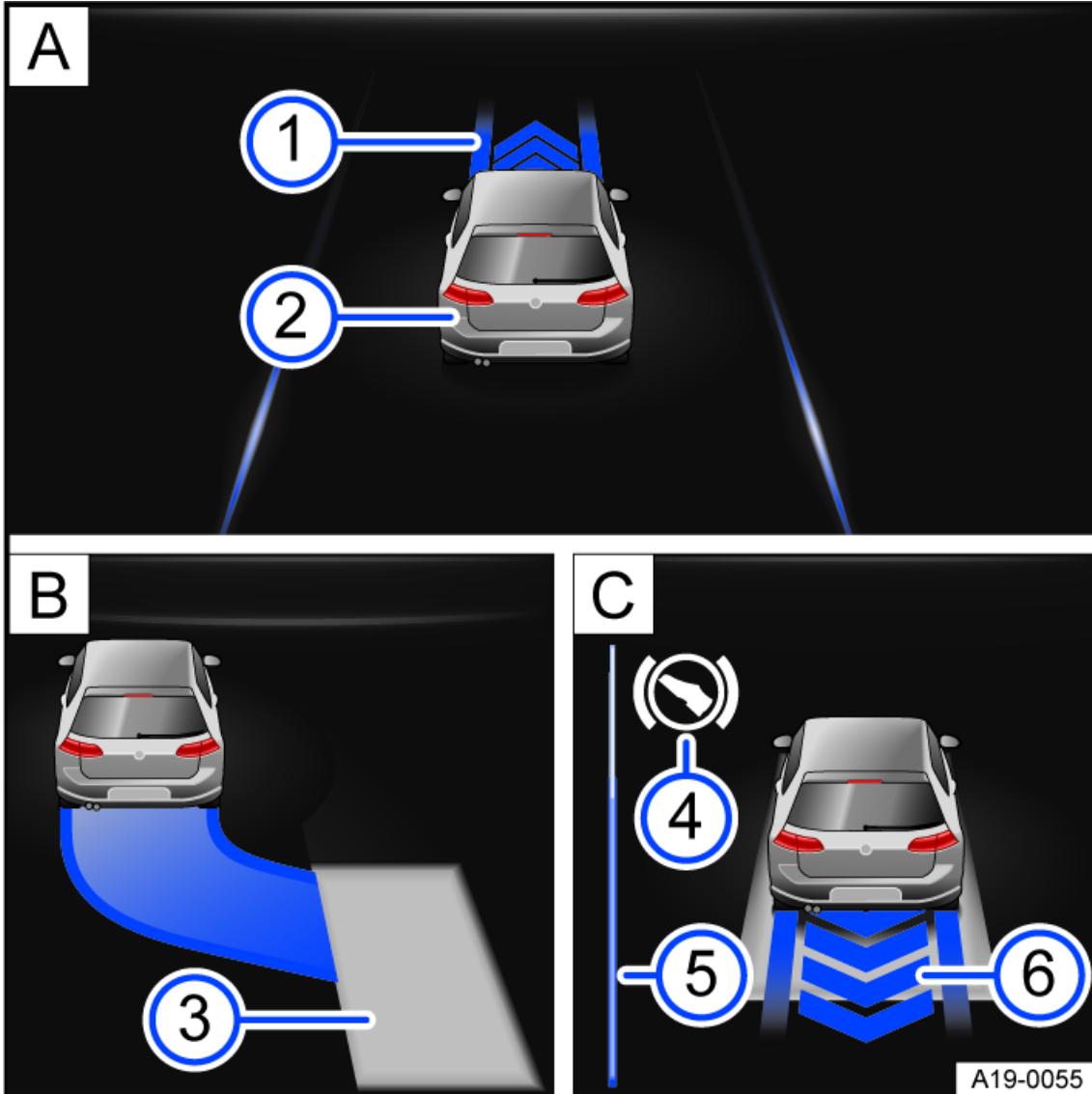

Fig. 117 In the digital instrument cluster display: drive into a parking space parallel to the road (general example).

A Search for a parking space.

B Driving into a parking space.

C Maneuvering into a parking space.

1 Prompt to drive forward.

2 Your vehicle.

3 Detected parking space.

4 Request to brake.

5 Progress bar (relative distance remaining).

- ⑥ Request to drive backwards (with driving direction arrow).

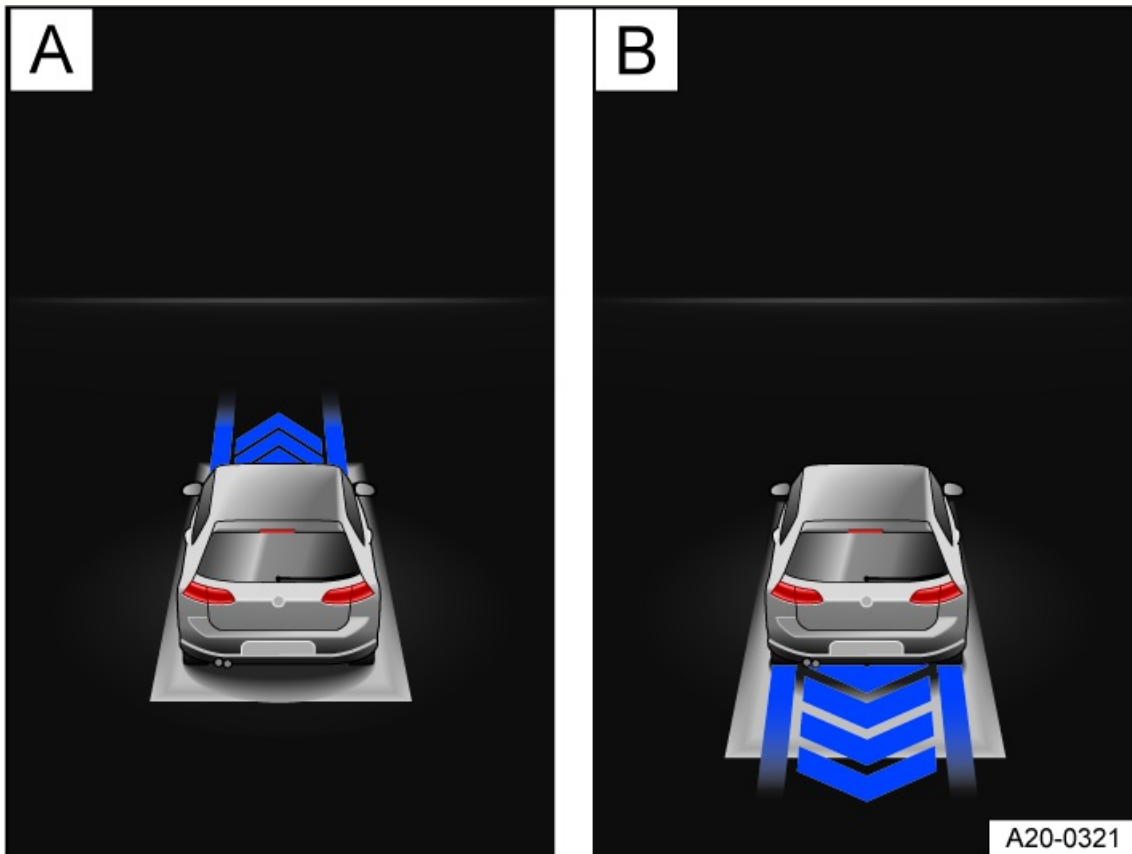



Fig. 118 In the digital instrument cluster display: prompt for changing driving direction (general example).

- A** Driving forwards.
- B** Driving backwards.

Requirements

- ✓ Park Assist has been activated.
- ✓ A parking space has been found and selected.
- ✓ The vehicle is in the starting position and its path is highlighted in blue in the Infotainment system.

Driving into parking spaces

1. Stop the vehicle with the brake.
2. Tap **(START)** in the Infotainment system.
Or: When driving in reverse into a parking space, engage the reverse gear **R**.
3. Release the steering wheel.
4. Release the brake.
5. Pay attention to the messages and indicators in the digital instrument cluster display.
6. Accelerate carefully.
7. If a chime sounds, the  indicator turns on or a message appears in the digital instrument cluster display, brake the vehicle.
8. If a change of driving direction is shown in the digital instrument cluster, change gear accordingly *fig. 118*. Follow the messages.
9. At the end of a parking maneuver, always wait until Park Assist has completed all rotational movements of the steering wheel in order to achieve an optimum parking result ⇒ .

10. Carry out several parking maneuvers if necessary.

When the process of driving into a parking space is finished, a message appears in the digital instrument cluster display.

11. Park the vehicle ⇒ *Parking*.

⚠ WARNING

During maneuvering, the steering wheel turns quickly. Interfering with the steering wheel can result in serious injury.

- Do not take over the steering until the system prompts you to do so.
- Take over the steering in dangerous situations.

Assistance during a parking attempt

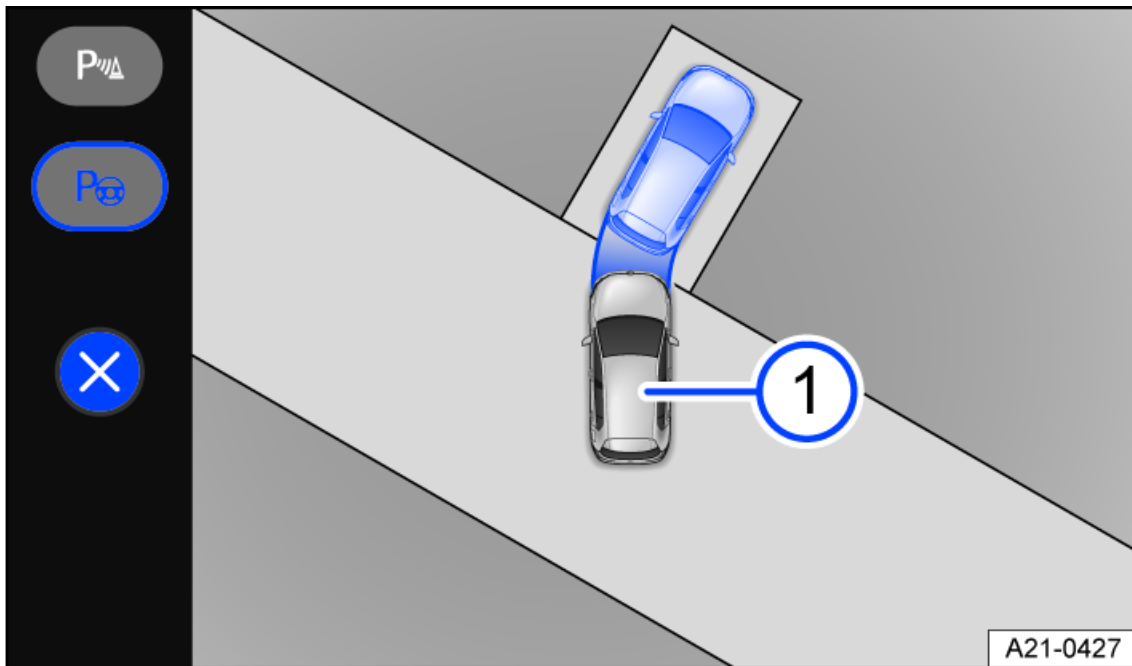

Fig. 119 Infotainment system: taking over the parking process from the driver.

① Vehicle “during” a parking attempt.

In difficult parking situations where an “attempt” at parking has already been made, Park Assist can take over the parking process and guide the vehicle into the parking space [fig. 119](#).

Requirements

- ✓ Park Assist is not activated.
- ✓ It is driven forwards or backwards into a parking space (“parked”).

Reversing into a parking space

1. Stop the vehicle with the brake pedal.

In the Infotainment system, the **P** button with a car icon indicates a detected parking space.

2. To switch to Park Assist, tap **P** button with a car icon.

3. Tap **START** to start the process of driving into a parking space.

Or: Engage reverse gear.

4. Release the steering wheel.

5. Release the brake and follow all the actions for parking as described from item 5.

Driving Forward into a Parking Space

1. Stop the vehicle with the brake pedal.
2. Tap the  control for the parking menu.
3. Tap **START** to start the process of driving into a parking space.

Or: Engage reverse gear.

4. Release the steering wheel.
5. Release the brake and follow all the actions for parking as described from item 5.

 If you stop a reverse parking process and reactivate Park Assist, the parking process can be started again.

 The lane shown on the Infotainment system during a parking process is a general example. It does not correspond to the actual parking process with Park Assist.

Exiting a parking space

 Please read the introductory information and heed the Warnings and Notice  and  *Safety instructions*.

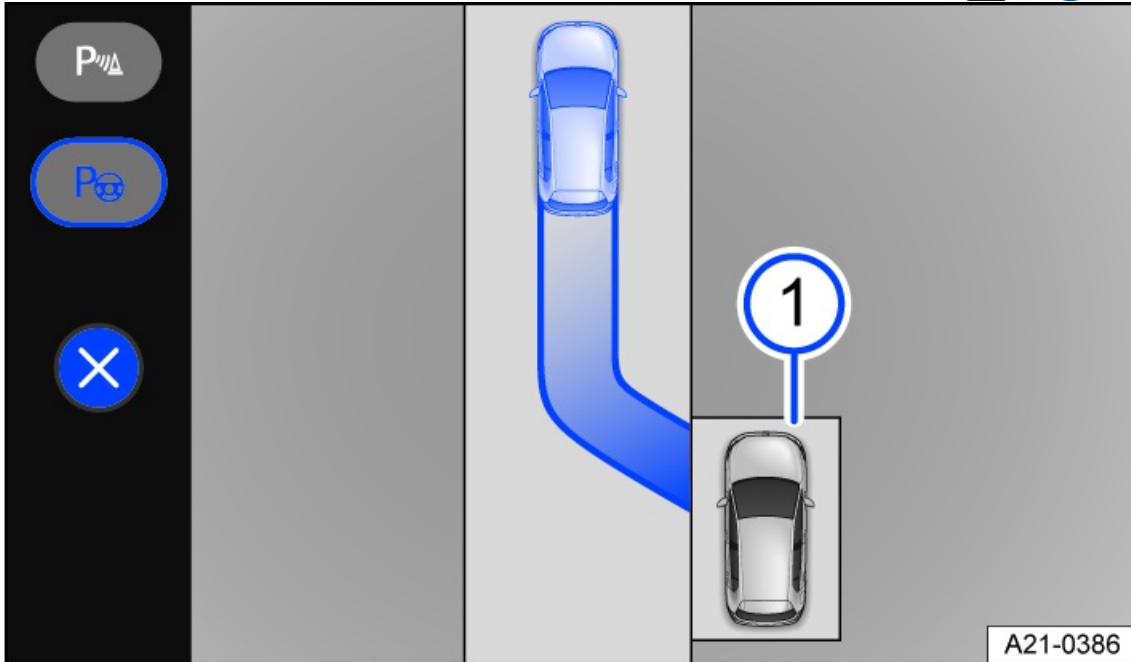



Fig. 120 Infotainment system: exiting procedure (general example).

 Vehicle in the parking space.

1. Start the engine.
2. Press and hold the brake pedal.
3. Activate Park Assist.
4. Activate the turn signal for the side of the road where the vehicle should drive out of the parking space.
5. Tap **START** on the Infotainment system screen.

Or: Engage reverse gear.

The parking maneuver to exit the space starts.

6. Release the steering wheel.
7. Release the brake.
8. Pay attention to the messages in the digital instrument cluster display.
9. If a chime sounds, the  indicator lights up, or a prompt to drive forward appears in the digital instrument cluster display

brake the vehicle.

Park Assist Plus fully guides the vehicle onto the road ⇒ .

A chime and a message from the Infotainment system signal that you have exited the parking space.

10. Resume control of the vehicle.

WARNING

When you maneuver out of a parking space, there is a danger of pulling into moving traffic. Accidents and serious or fatal injuries may occur.

- Only drive the vehicle out of the parking space when the traffic situation allows it.

 The lane shown on the Infotainment system during a parking process is a general example. It does not correspond to the actual parking process with Park Assist.

Troubleshooting

 Please read the introductory information and heed the Warnings and Notice ⇒  and  *Safety instructions*.

Park Assist is canceled automatically

Park Assist will end the parking process if one of the following situations occurs:

-  is pressed.
- The driver takes over steering.
- The driver's door is opened.
- The time limit or number of movements for the parking process is exceeded.
- ASR is switched off or it engages.
- There is a system malfunction.

1. Restart the parking process.

Park Assist is active and supports steering movements when the vehicle is stationary

If Park Assist attempts to turn the steering while the vehicle is stationary, the white  symbol appears in the digital instrument cluster display.

1. Press the brake pedal.

After a wheel change, Park Assist parks inaccurately

If, after a wheel change, Park Assist parks inaccurately, e.g. with an increased or reduced distance from the curb, the system may have to reacquire the wheel sizes.

1. Drive the vehicle over a longer distance, including around bends.

The Park Assist system automatically learns the new wheel sizes.

Rear Traffic Alert

The Rear Traffic Alert monitors the cross traffic behind the vehicle when reversing out of a space or maneuvering.

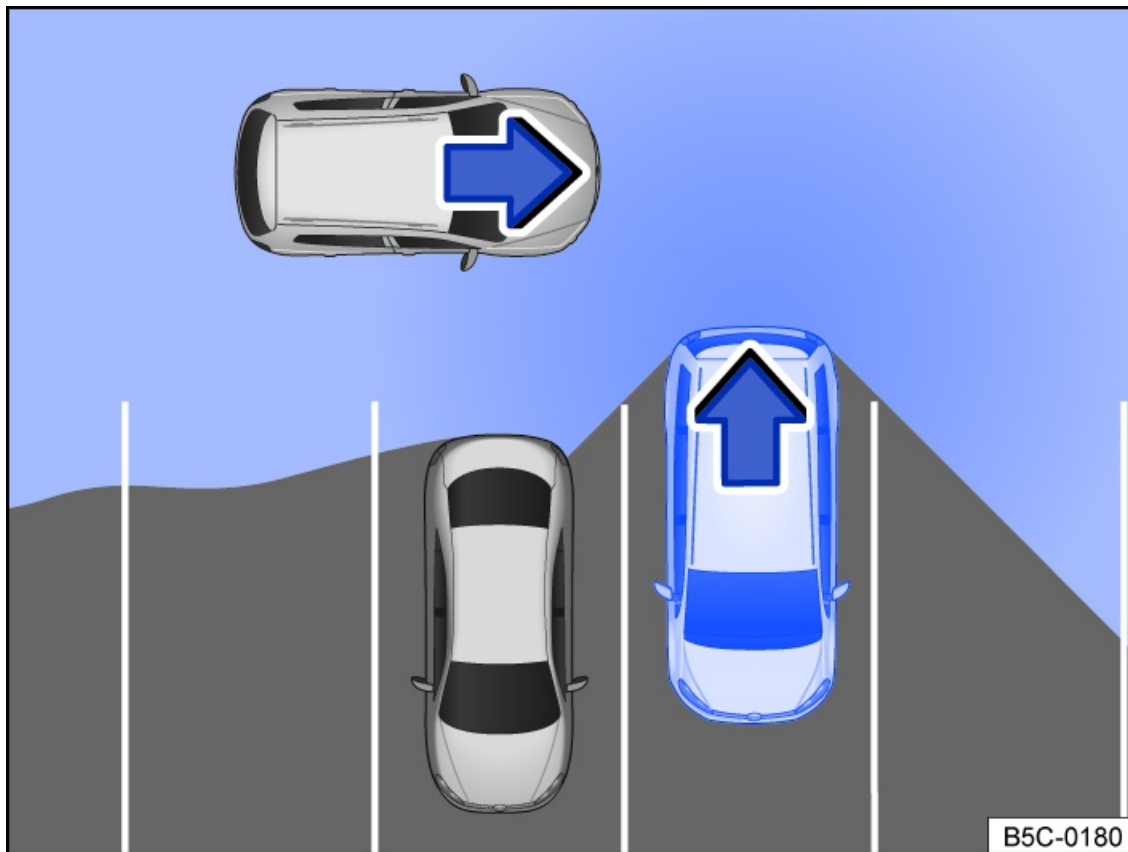

Fig. 121 Monitored area around the vehicle that is exiting a parking space (general example).

Radar sensors behind the cover of the rear bumper monitor the rear and side areas of the vehicle.

In the event of approaching, moving objects, the driver is warned of the obstacle [fig. 121](#), ⇒ . A warning signal sounds and, depending on the vehicle equipment, a colored display of the obstacle area is shown in the Infotainment system [fig. 122](#) or a warning light with a message is displayed in the instrument cluster.

Obstacle detected.

If the driver does not respond, automatic braking support may kick in → page , *Automatic braking intervention*.

WARNING

Rear Traffic Alert is not a replacement for the driver's attention and works only within the system limitations. All approaching objects, e.g. pedestrians or objects approaching quickly, may not be detected. If you are careless, there is a risk of accidents, serious injuries and death.

- Always stay attentive and do not rely solely on the system. The driver is always responsible for control of the vehicle.
- Pay attention to the traffic situation and the vehicle environment when leaving a parking space.
- React quickly to the visual warnings and warning chimes of the Rear Traffic Alert system.

Switching on and off

1. Press the button on the steering wheel to select the function in the instrument cluster.

Or: tap the control in the upper section of the center console.

Tap the function key in the Infotainment system.

2. Switch the Rear Traffic Alert on or off.

Screen display

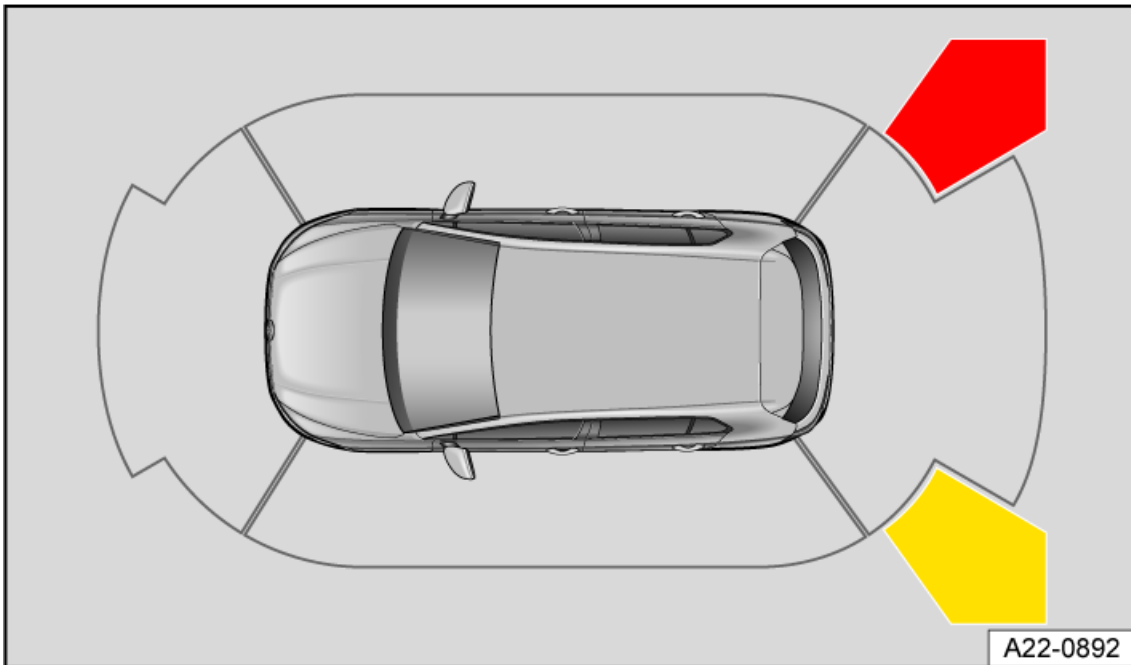



Fig. 122 Infotainment system: Rear Traffic Alert display (depending on the vehicle equipment).

 Red section of the image: nearby obstacle. The vehicle is at risk. Reverse out of the space carefully and brake if necessary.  Yellow section of the image: other road users in the vicinity of the vehicle.

Driving with a trailer

Rear Traffic Alert cannot be activated if a trailer is connected to the electrical system. After disconnecting the trailer connection, Rear Traffic Alert will be reactivated after an ignition cycle.

If the trailer hitch was not installed at the factory, Rear Traffic Alert must be manually deactivated.

Practical equipment

Storage compartments

Introduction

WARNING

Loose objects can be thrown around the inside of the vehicle during sudden driving or braking maneuvers. This can cause a loss of vehicle control, and can cause accidents and serious or fatal injuries.

- Store objects in only closed storage compartments.
- Always keep the storage compartments closed while driving.
- Do not place mobile devices or similar objects in the rear center armrest storage system while driving.
- Only hang lightweight clothing, up to a maximum of 2.5 kg (approximately 5.5 lbs), from the coat hooks in the vehicle.
- Never leave heavy, hard or sharp objects in clothing pockets.

WARNING

Incorrect usage of the cup holders can cause injuries. While driving, during a sudden braking maneuver or in the event of an accident, objects in the cup holder may be thrown around and hot drinks may be spilled. This can cause serious injuries and serious burns.

- Only stow soft, break-resistant, closed vessels in the cup holder.
- Integrated storage systems of the rear center armrest must always be used in the locked end positions.
- Do not place hot beverages in the cup holders.
- Take care that only suitably sized drinks are stored in the cup holder. Drinks must always be steady and secure in the cup holder.

WARNING

If the glove compartment is open while you are driving, objects may be flung into the vehicle interior. This can cause a loss of vehicle control, and can cause accidents and serious or fatal injuries.

- Always keep the glove compartment closed while driving.

WARNING

Lighters in the vehicle can become damaged or ignite unintentionally, for example due to high surface temperatures. This can cause severe burns and vehicle damage.

- Before closing compartments or storage areas, always make sure that there are no cigarette lighters near the sections that will be closing.
- Never place lighters in compartments, in storage areas, or on other surfaces in the vehicle.

⚠ WARNING

Closed beverage bottles can explode from heat and burst from frost in the vehicle and cause serious injuries.

- Never leave closed beverage bottles in an extremely hot or extremely cold vehicle.

ⓘ NOTICE

Objects stored in the vehicle may be damaged by strong sunlight or the effects of heat or cold or cause damage to the vehicle.

- Never leave any objects, groceries, or medications that are sensitive to temperature in the vehicle interior.
- Bear in mind that objects made from transparent materials, e.g. transparent suction cups on door windows, can concentrate sunlight.

ⓘ NOTICE

Depending on the vehicle equipment, the rear center armrest may have a storage system. Folding in the rear center armrest with the storage system open can damage the cup holder.

- Before folding in the rear center armrest, make sure that objects have been removed and that integrated storage systems are closed or folded in.

Cup Holder in the Rear Center Armrest

📖 Please read the introductory information and heed the Warnings and Notice ⇒ ⚠ and ⓘ *Introduction*.



Fig. 123 In the backrest of the center seat: folding rear center armrest (general example).



Fig. 124 In the rear center armrest: cup holder (general example).

There is a cup holder in the rear center armrest.

- To fold forward: pull the center armrest in the direction of the arrow with the loop *fig. 123*.
- To fold back: fold the center armrest upward in the opposite direction to the arrow and press it all the way toward the seat backrest *fig. 123*.

Passengers must not sit in the center rear seat when the center armrest is folded down.

Sockets

Introduction

Electrical devices can be connected to the sockets in the vehicle.

The 12 V socket only works when the ignition is switched on.

WARNING

Using sockets and connected electrical devices incorrectly can cause fires and serious or fatal injuries.

- If the electrical devices become too warm, turn off the devices immediately and disconnect them.
- Be aware that sockets and devices connected to them may still be used, e.g. by children in the vehicle, when the ignition is switched off.

NOTICE

Electrical devices that are unsuitable, not permitted, or connected incorrectly may cause damage to the vehicle or electronics.

- Never connect electrical devices that provide power, such as solar panels or battery chargers, to the 12 V socket in order to charge the 12 V vehicle battery.

- Only use electrical devices that have been tested for compliance with the applicable directives for electromagnetic compatibility.
- Do not use any malfunctioning devices.
- To reduce the risk of damage from voltage fluctuations, turn electrical devices off before switching the ignition on or off and before starting the engine.
- Refer to the operating instructions for the electrical devices.

ⓘ NOTICE

The vehicle electrical system can be damaged when the maximum load is exceeded.

- Never connect electrical devices that draw more than the specified load of a 12 V socket.

ⓘ The 12 V vehicle battery will drain if the ignition and electrical devices are switched on while the engine is switched off.

ⓘ Unshielded devices can cause malfunctions in the radio, the Infotainment system and in the vehicle electronics, depending on the vehicle equipment.

Sockets in the vehicle

📖 Please read the introductory information and heed the Warnings and Notice ⇒ ⚠️ and ⓘ *Introduction*. Do not exceed the maximum power of the sockets. The power draw of the external devices is indicated on their identification labels.

12 V socket



Fig. 125 In the lower part of the center console, at the rear of the center console or on the left-hand side of the luggage compartment: Hinged 12-volt socket (general example).

The total continuous output of all 12 V sockets in the vehicle is 120 W ⇒ 📖 *Introduction*.

The maximum power of a 12 V socket in the vehicle with the engine running totals 180 W.

ⓘ NOTICE

Using 12 V sockets for too long at maximum power can cause the fuse to blow.

- Never use 12 V sockets at their maximum power for longer than 10 minutes.
- Only ever use a single 12 V socket at maximum power.

! NOTICE

When using two or more 12 V sockets at the same time, the total power draw of the connected electrical accessories must not exceed 190 W. This can cause the fuse to blow.

- Only ever use a single 12 V socket at maximum power.

115 V socket



Fig. 126 In the center console at the rear: 115 V socket (depending on the vehicle equipment).

The maximum power is 150 W (peak power: 300 W).

The socket is activated automatically if you plug in a connector while the engine is running. If enough power is available, you may be able to use the socket, even if you have switched off the engine ⇒ ⚠.

Connecting an electrical device

1. To unlock the integrated child safety lock, press and hold the cover on the right edge if necessary.
2. Insert the connector all the way into the socket.

Temperature cut-off

The inverter of the 115 V socket automatically shuts down when a certain temperature is exceeded. The cut-off prevents overheating due to devices that are connected drawing excessive power and overheating due to high ambient temperatures. You will not be able to use the 115-volt socket again until it has cooled down.

In order to use the 115-volt socket again once it has cooled down, if a device is connected you must remove the connector

connecting it to the socket and then plug it back in again. This prevents electronic devices from inadvertently being switched back on.

DANGER

Contact with high voltage in the electrical system, e.g. sockets, may cause electric shocks, serious burns, and fatal injuries.

- Do not spill any liquids on the socket.
- Do not insert any adapters or extension cables into the 115-volt socket with earthing contact.
- Do not insert any conductive items (e.g. a screwdriver) into the contacts of the 115-volt socket with earthing contact.

NOTICE



The sockets on the vehicle can be damaged by improper operation. This may result in damage to the electronics and the vehicle.

- Only connect devices to the socket if the voltage of these devices matches the socket voltage.
- Do not suspend excessively heavy devices or connectors (e.g. power supply units) directly from the socket.

 If electrical equipment with a high starting current is prevented from being switched on, the integrated overcurrent shutdown may be the cause. In this case, disconnect the power supply unit from the electrical device and reconnect it after about 10 seconds.

 With some devices, the functionality of the 115-volt socket may be impaired due to the relatively low power (wattage).

Charging Options for Mobile Devices

 Please read the introductory information and heed the Warnings and Notice  and  *Introduction*.

You can charge mobile devices in the vehicle either wirelessly or by using the built-in USB-C connectors.

Charging with USB-C Connectors

The vehicle may contain the following USB-C ports:

 Symbol for a USB port for data transmission and charging.  Symbol for a USB port for charging only.

Available Charging Power

Voltages up to 20 V are provided via the USB port, which enables up to 45 W charging power.

Depending on the vehicle equipment, the following charging profiles may be supported by the USB ports:

- Legacy charging (2.5 W).
- BC1.2 (7.5 W).
- USB-C charging (15 W).
- USB power delivery (up to 45 W).

The actual charging power of the connected device depends on the following aspects:

- Supported charging profiles.

- Device charge level.
- Device temperature.
- Charging cable used.

 For double USB ports, the charging power can be split between both ports.

Wireless charging function

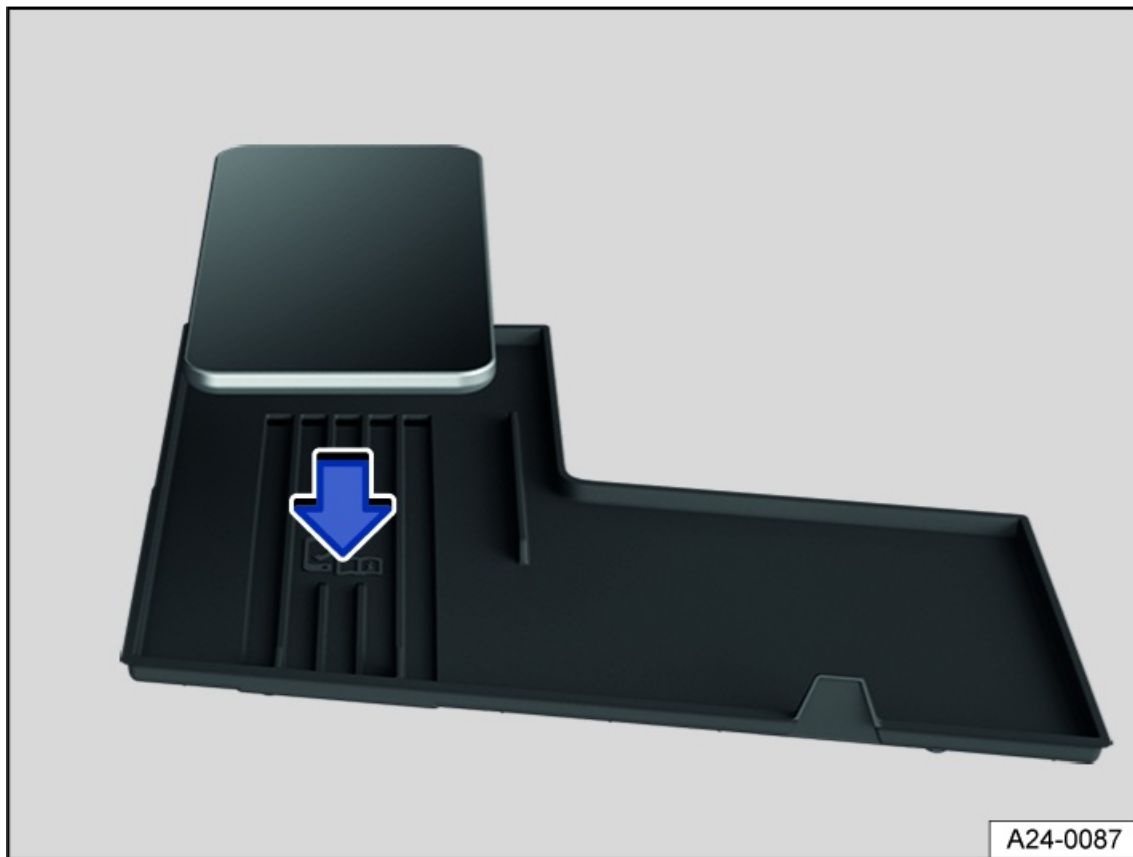

Fig. 127 In the center console: liner pad for wireless charging function (general example).

The wireless charging function depends on the vehicle equipment and is not available in all countries.

Wireless charging enables wireless energy transfer through electromagnetic induction over a short distance for cell phones that are Qi-certified.

The liner pad with a rear shelf for the wireless charging function is located in the area of the center console and is designed for only one Qi-certified cell phone at a time *fig. 127*.

On some vehicles, the liner pad has a telephone symbol indicating the center position *fig. 127*.

The charging capacity is 15 W.

If the vehicle interior is cooled by the air conditioner, cool air is directed into the storage compartment, depending on the vehicle equipment.

Qi Standard

The Qi standard enables wireless charging of suitable Qi-certified cell phones. To find out whether a cell phone supports the Qi standard, see the cell phone operating instructions. An overview of Qi-certified cell phones can be viewed under the following external link of the Wireless Power Consortium, Inc:

<https://www.wirelesspowerconsortium.com/products>

Volkswagen AG assumes no liability for the completeness and accuracy of this list. The manufacturer of the cell phone may provide additional information regarding compatibility.

Cell phones that are not Qi-certified may be subject to limitations with regard to wireless charging.

The Qi symbol  is displayed in the Infotainment system to indicate the status of wireless charging.

Wireless Cell Phone Charging

Requirements

- ✓ The optimum operating temperature in the vehicle for wireless charging is between -40 °C and +35 °C.
- ✓ A suitable cell phone that is no larger than the designated rear shelf and is Qi-certified.

1. Remove any foreign objects from the storage compartment prior to charging ⇒ .
2. Remove the protective case of the cell phone and any other foreign objects (if present), then place the cell phone flat against the rear shelf with the display facing upward.

The charging process starts automatically.



3. Refer to the operating instructions for the cell phone.

The Infotainment system informs you when the charging process is starting and, if applicable, if there are any foreign objects with metal components in the storage compartment.

Depending on the vehicle equipment, the charging function can be deactivated manually in the Infotainment system.

 If the ambient temperature in the vehicle is outside the temperature range from -40 °C to +35 °C, the charging process may be interrupted or the charging duration extended. Wireless charging will start working normally again as soon as the ambient temperature in the vehicle is back within the temperature range.

Meaning of the Qi symbols

 The white Qi symbol indicates that the cell phone is charging.  The red Qi symbol indicates that wireless charging is not possible.

Depending on the vehicle equipment, tap the Qi symbol for an explanation of the status and, if necessary, to switch on wireless charging.

Storage compartment cover

The storage compartment for the wireless charging function may have a cover for the cell phone display.

The cover can prevent you from being distracted by the cell phone, e.g. by incoming notifications.

1. Place the cell phone in the storage compartment.
2. Keep the cover closed while driving so that the cell phone display is completely covered ⇒ .

WARNING

Notifications on the cell phone display may distract the driver. This can result in accidents and serious injury or death.

- Make sure that no objects interfere with the closing function of the cover.
- If the rear shelf includes a cover, always keep the cover closed while driving.

WARNING

Metal objects on the shelf can become very hot. This may cause burns or fires.

- Do not place metal objects or objects with metal components on the wireless charging shelf.
- Remove any foreign objects immediately.



NOTICE

If cards or other objects with magnetic strips or with chips are placed on the rear shelf for wireless charging, the data stored on these may be damaged.

- Do not place any ID cards, debit cards or credit cards with magnetic strips or chips on the wireless charging shelf.

 The cell phone can become hot during cordless charging. Keep the vents clean as they improve the air supply around the cell phone *fig. 127*.

Troubleshooting

 Please read the introductory information and heed the Warnings and Notice  and  *Introduction*.

Cell phone is not Charging

A message regarding a foreign object in the storage compartment may be displayed in the Infotainment system.

If the cell phone is in an unfavorable position on the liner mat, this can impair the charging function. This can be caused by changes in position – even small shifts that may occur as a result of vibrations, for example.

The position of the cell phone must be corrected in order to restore correct charging function.

1. Align the cell phone centrally on the charging surface.

The charging function can also be impaired by metallic parts – in particular, magnetic parts of a cell phone or its protective case.

1. Rotate the mobile phone approx. 180° with the display still facing upward on the charging surface.

If cards or other objects with magnetic strips or with chips are placed on the liner pad for wireless charging, the data saved on these may be damaged.

Depending on the model, an error message with the red Qi symbol can be displayed in the Infotainment system. In these conditions, it is not possible to use the cordless charging function.

1. Remove IDs, bank cards and credit cards with magnetic strips or with a chip from the liner pad. The error message is automatically closed.

You can then charge the cell phone again with the wireless charging function.

 If the cell phone on the liner pad becomes too hot, it may switch off for safety reasons. In these conditions, it is not possible to use the cordless charging function.

1. Take the cell phone off the liner pad and allow it to cool in another storage compartment. You can then charge it again with the wireless charging function.

Data transmission

Cyber security

Cyber security describes measures that reduce the risk of illegal access to vehicle functions, data and control modules caused by malware or an Internet attack. Of all the components in the vehicle, connectivity components are most at risk of unauthorized access or cyber attacks.

Connectivity components comprise control modules for data transmission, interfaces, media and diagnostic connections through which information and data can be exchanged between the vehicle and mobile devices or the Internet.

Connectivity components are equipped with security mechanisms to minimize the risk of unauthorized access to vehicle systems.

Connectivity components include in particular:

- Diagnostic connection port
- Control module with installed eSIM card.
- Phone interface
- App-Connect.
- Wi-Fi® hotspot.
- NFC radio technology.
- Bluetooth® interface.
- USB port.
- SD card slot.

 The type and number of connectivity components present in your vehicle depends on the vehicle equipment and the country.

Software and security mechanisms

Software and security mechanisms available in the vehicle undergo continuous development. Similar to computers or operating systems on cell phones, software and security mechanisms in the vehicle may also be updated at various times.

Updates improve the security, stability and operating speed of vehicle systems. The update is a preventative measure, for example, to protect from malware and to optimize functionality.

An update is used to update the software of control modules in the vehicle.

Depending on the vehicle and country, there are two ways to update your vehicle:

- Updates by suitably qualified professionals. Volkswagen recommends contacting an authorized Volkswagen dealer or authorized Volkswagen Service Facility.
- Updates via an Over-the-Air Update.

WARNING

Malware can access data and information stored in the control modules, in the Infotainment system and on connected or paired mobile devices. In spite of the integrated security mechanisms and regular Over-the-Air Updates, malware can cause damage and malfunctions in control modules and the vehicle. In the same way, connecting mobile devices that are infected with malware can result in damage and malfunctions in control modules and the vehicle. The damage can lead to

a complete loss of your data and malfunctions can cause serious accidents and fatal injuries.

- If the vehicle works or reacts differently to normal, reduce your speed in a controlled manner and contact an authorized Volkswagen dealer or authorized Volkswagen Service Facility.
- Perform pending updates as soon as possible once they are made available or have them performed by suitably qualified professionals.
- Protect your mobile devices with a suitable antivirus program and by taking commonly known precautions. Regularly update the antivirus program using the supplied updates provided by the vendor.

Minimizing risks

You can actively help to reduce the risk of unauthorized access to vehicle systems and functions by following these guidelines:

- Only use data carriers, Bluetooth devices and cell phones in the vehicle that do not contain any manipulated data or malware.
- Ensure that updates provided by Volkswagen are carried out by suitably qualified professionals as soon as possible once they are made available. Volkswagen recommends contacting an authorized Volkswagen dealer or authorized Volkswagen Service Facility. If the option to perform Over-the-Air Updates is available, depending on the vehicle and country, carry out all updates provided by Volkswagen immediately. If the Over-the-Air Update is ignored multiple times by the driver, an authorized Volkswagen dealer or authorized Volkswagen Service Facility must be contacted for assistance. Volkswagen recommends contacting an authorized Volkswagen dealer or authorized Volkswagen Service Facility.
- Only have the vehicle repaired and serviced by suitably qualified professionals. Volkswagen recommends contacting an authorized Volkswagen dealer or authorized Volkswagen Service Facility.

Over-the-Air Update

Introduction

Over-the-Air Updates enable you to ensure that the control software of your vehicle is kept up to date, e.g. to protect against malware and optimize functionality.

Over-the-Air Updates are only available to you after creating the Volkswagen ID and activating VW Car-Net®. You can activate VW Car-Net® during the creation of the Volkswagen ID.

Additional information on using the online services can be found online at:

vw.com/carnet.

How can you tell that an Over-the-Air Update is pending?

As soon as an Over-the-Air Update is available, you will be informed of this via a pop-up. Tap on the pop-up and on Additional information to obtain more information about the Over-the-Air Update, or visit the following website:

vw.com/software

If multiple Over-the-Air Updates are available for the vehicle at the same time, one Over-the-Air Update must be completed successfully before the next Over-the-Air Update can be carried out.

 Over-the-Air Updates should be performed promptly.



In very rare circumstances, it is possible that a control module may no longer work properly after an Over-the-Air Update. Malfunctions in a control module and the vehicle can cause serious accidents and fatal injuries.

- If the vehicle works or reacts differently to normal while driving, reduce your speed in a controlled manner.
- Contact an authorized Volkswagen dealer.

WARNING

If the digital instrument cluster malfunctions after an Over-the-Air Update, it will not be possible to display instruments, warning lights, symbols or messages. Driving with a malfunctioning instrument cluster can lead to serious accidents and fatal injuries.

- Do not use the vehicle. Contact Volkswagen Customer Care.



NOTICE

If special modifications are made to vehicles outside of the responsibility of Volkswagen, such as for service vehicles or taxis, there is a risk that these special functions will no longer work properly after an Over-the-Air Update.

- Contact your authorized Volkswagen dealer before performing an Over-the-Air Update.



 Measures to increase performance or efficiency (e.g. engine tuning) that are not performed by Volkswagen may be reverted by an Over-the-Air Update.

Requirements for an Over-the-Air Update

 Please read the introductory information and heed the Warnings and Notice ⇒  and  *Introduction*. The following requirements must be met so that the download and the installation of an Over-the-Air Update can be performed.

- ✓ You have created a Volkswagen user account.
- ✓ You have added the VIN of your vehicle to your myVW garage.
- ✓ The vehicle is in an area with enough mobile reception.
- ✓ The 12-volt vehicle battery is sufficiently charged.
- ✓ The vehicle is parked safely in accordance with legal requirements and local conditions ⇒ *Parking and maneuvering*.
- ✓ The vehicle is not being charged.
- ✓ The previous Over-the-Air Updates have been installed.

Downloading and installing an Over-the-Air Update

 Please read the introductory information and heed the Warnings and Notice ⇒  and  *Introduction*.

Download costs

An Over-the-Air Update is downloaded via the factory-installed control module with an eSIM card and is free of charge. Volkswagen pays the connection charges.

Availability of the Over-the-Air Update

As soon as a new software version is available for your vehicle, you will be notified of this in the myVW app.

1. Open the app.

2. Follow the instructions in the app.
3. Request the Over-the-Air Update.

 It may take several weeks until the download is started in your vehicle.

As soon as the download is available, you will be informed of this after the engine is switched off.

Duration of Download

The download is performed while driving. The download time depends on the network quality, file size and Over-the-Air Update type. It may be the case that the download is interrupted. In this case, the download will resume when the ignition is switched on. You will be notified as soon as the download is complete.

Carrying out software installation of the Over-the-Air Update

Select a time for the Over-the-Air Update during which the vehicle does not need to be driven by you or anyone else, and does not need to be charged.

WARNING

Control units are deactivated and will not be operational for the duration of the software installation. Driving with deactivated or non-functioning control units can lead to accidents and fatal injuries.

- Carry out the software installation so that other road users are not affected.
 - Never operate your vehicle during a software installation.
1. Stop the engine and set the electronic parking brake.
 2. Close the engine hood, trunk lid, all windows and all doors.
 3. Ensure that all vehicle occupants leave the vehicle and that no animals are left in the vehicle.
 4. Tap Update available ► Install.
 5. Exit the vehicle, taking all vehicle keys with you.
 6. Lock the vehicle.

Functional limitations during software installation

The control modules, the main computer, functions and displays will not be available during software installation. Do not use the vehicle during this process and do not operate the Infotainment system.

- Mobile online services are not available.
- The Emergency Call Service, Roadside Call Assist and the legally required eCall Emergency System are not available.
- Park Distance Control is not available.

Following the software installation

After the software installation and before starting the engine, read the message regarding completion of the software installation in the Infotainment system or instrument cluster. The vehicle will require up to 1 minute to display the status of the Over-the-Air Update.

- The engine can be restarted following the successful software installation.
- If the software installation is unsuccessful: → page , *Troubleshooting*.

Troubleshooting

 Please read the introductory information and heed the Warnings and Notice ⇒  and  [Introduction](#).

Installation of an Over-the-Air Update has failed

- If the installation of an Over-the-Air Update was not successful, a corresponding error message will appear in the Infotainment system or instrument cluster. Take note of corresponding messages and warning notifications.

 If there was a critical installation error, control modules may no longer function or not function correctly. Functions and displays will not be available until the error is rectified. Do not use the vehicle. If this is the case, contact Volkswagen Customer Care.

Can I interrupt the installation of an Over-the-Air Update?

No, this is not possible.

What happens if installation of an Over-the-Air Update is interrupted?

If installation is interrupted, e.g. due to damage to the vehicle's electrical system, control modules may not be updated and may be damaged by the incomplete installation of the Over-the-Air Update.

Wired and wireless connections

[Introduction](#)

Mobile devices can be connected to the Infotainment system via the wired and wireless connections in the vehicle.

The type and number of wired and wireless connections depends on the vehicle equipment and the country. The connections may differ within a model line or in a model with optional equipment.

In wired connections, only use the original connecting cable that belongs to the device or the connecting cable that was placed in the vehicle at the factory, if available.

If the plug on the connector cable cannot be inserted, check the position and the connections.

NOTICE



If you use unsuitable or damaged connector cables and if you insert the plug on the connector cable with excessive force or in the wrong position, this can lead to malfunctions and damage to the device, e.g. the device connection and the plug on the connector cable can be damaged.

- Only use suitable and undamaged connector cables.
- Hold the plug on the connector cable in the correct position and insert it into the intended socket while pressing lightly.
- Make sure the connector cable is not trapped or bent excessively.

 If a connected device is not recognized, disconnect all connected devices and then reconnect the device. Check the function of the connector cable used, if necessary.

 If malfunctions occur in a connected device, restart the device. This sometimes fixes the error.

USB port

 Please read the introductory information and heed the Warnings and Notice ⇒  [Introduction](#).

Using the USB port, you can transfer data and charge devices or only charge devices.

USB-C port

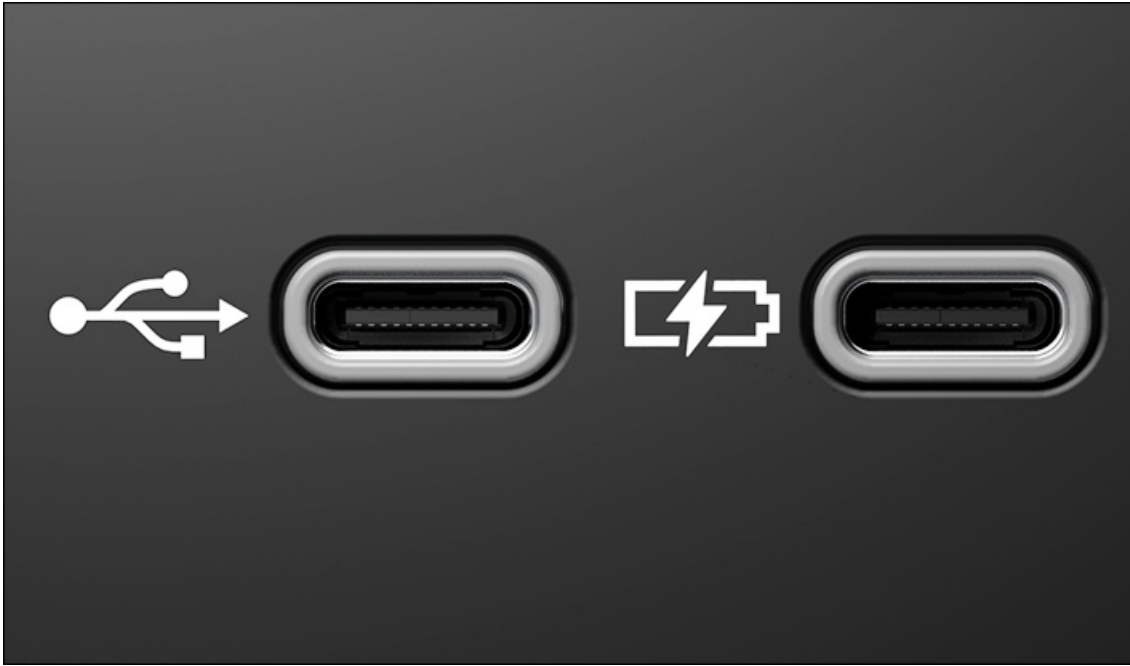

Fig. 128 USB-C connection in the vehicle (general example).

The vehicle may contain the following USB-C ports:

☛ Symbol for a USB port for data transmission and charging. ⚡ Symbol for a USB port for charging only. You can find information about charging options and charging capacity in this Owner's Manual ⇒ [Charging Options for Mobile Devices](#).

Possible USB port installation locations

The number and installation locations of the USB ports depend on the vehicle and vehicle equipment and are not available in all countries.

- In the center console.
- At the base of the interior rearview mirror.
- In the storage compartment in the center console.
- In the compartment underneath the center armrest.

 USB ports at the rear seats only come with a charging function.

Available Data Transfer Functions



The following USB data transfer functions are available depending on the vehicle equipment.

- App-Connect ⇒ [App-Connect](#).
- Media playback ⇒ [Media](#).
- Update, e.g. of the navigation data ⇒ [Navigation data](#).

Instructions and restrictions

- Only use suitable USB connection cables. The USB connection cable must match the USB port installed in the vehicle.
- Dirty, overheated or damaged data carriers are not to be used. Read and heed the information provided by the manufacturer.
- Difference in quality between data carriers from different manufacturers can cause problems with media playback.
- Using USB extension cables, USB adapters or USB hubs may result in malfunctions or failure of the USB functions.

Bluetooth® interface

 Please read the introductory information and heed the Warnings and Notice ⇒  [Introduction](#).

The Bluetooth interface is a wireless connection.

In Bluetooth audio mode, audio files on a mobile device that is connected via Bluetooth, such as a cell phone, can be played through the vehicle speakers.

Bluetooth audio mode is only possible in vehicles equipped with a factory-installed mobile phone interface that supports this function.

Bluetooth profiles

A maximum of three mobile devices can be connected simultaneously via Bluetooth: two for telephony and one for music playback.

The following Bluetooth functions are supported:

- Telephony and handsfree mode.
- Music playback.
- Display and operation for music playback.
- Transfer of cover art.
- Access to phone book and call lists.
- Access to SMS and e-mail.

Requirements for using the Bluetooth interface for music playback

- ✓ The mobile device supports the Bluetooth profile Advanced Audio Distribution Profile (A2DP).
- ✓ The audio and media transfer to the Infotainment system must be allowed in the settings on the mobile device.

You can find more detailed information about using the mobile device for music playback in this Owner's Manual ⇒ [Media](#).

Pairing your mobile device to your vehicle via Bluetooth

There are various options for pairing your cell phone with the vehicle via Bluetooth. The simplest option is pairing via one of the following main menus: Radio/Media or Phone.



Pairing via Phone

1. Open the app overview and tap Phone.
2. Follow the instructions in the Infotainment system.
3. To connect another cell phone if cell phones are already connected, tap  ► Select cell phone.
4. Select the cell phone to be connected.

Pairing via Radio/Media

1. Open the app overview and tap Radio/Media ► Media ► Source ► Bluetooth.
2. Follow the instructions in the Infotainment system.
3. If Bluetooth is already selected under Source but another cell phone is to be used, tap Source ► Bluetooth again.
Or: tap  ► Media ► Select Bluetooth audio device.

Mobile Devices Menu

 If pairing via the phone interface or the Radio/Media menu should fail, pairing can also be performed in the  ► Network ► Mobile devices menu.

1. In the app overview, tap  ► Network ► Mobile devices.

2. With the factory settings, both Bluetooth and visibility are always activated. If Bluetooth should be deactivated, tap  to activate Bluetooth and Visibility.
3. Open the list of available Bluetooth devices on your cell phone and select the Bluetooth device name for the Infotainment system. In the factory settings, the Bluetooth® device name of the Infotainment system is “my VW” and the last four digits of the VIN.
4. Pay attention to messages on the cell phone and in the Infotainment system and confirm these if necessary.
If the pairing is successful, the data on the cell phone will be saved in the user profile.
5. *Optional:* Confirm the message for transferring the data on the cell phone.

 You generally only need to pair a cell phone once. You can reestablish the cell phone's connection to the Infotainment system at any time via Bluetooth, without re-pairing the cell phone.

 The extent to which the cell phone connected via Bluetooth can be controlled via the Infotainment system depends on the mobile device.

 Please refer to this Owner's Manual → [Mobile phone interface](#) for more detailed information on the use of a cell phone via a Bluetooth connection.

 Generally, all warning and operation tones on a connected cell phone, such as touch tones, should be switched off to avoid interference and malfunctions.

Internet use in the vehicle

Introduction

Depending on the country and the vehicle equipment, you have two options for using the Internet in your vehicle: via the hotspot of a mobile device, e.g. a cell phone, or via the eSIM of the vehicle → [Setting up the Internet connection](#).

In order to use the eSIM, you need to purchase data plans via the web shop of Volkswagen's external mobile communications partner. In order to use the mobile online services, you need a subscription to them and to consent to the General Terms and Conditions and Terms of Use. Additional information can be found online at:

carnet.vw.com

You can use the Infotainment system as a Wi-Fi® hotspot for eight further mobile devices ⇒ [Quick connection](#). This function depends on the vehicle equipment and is not available in all vehicles.

Setting up the Internet connection

Using the Internet in the vehicle via the eSIM

 The option for using an Internet connection in the vehicle via the eSIM depends on the vehicle equipment and the country.

In order to use an Internet connection via the eSIM of the vehicle, you need to purchase data plans via the web shop of Volkswagen's external mobile network provider.

 Due to the large number of mobile devices that are available, there is no guarantee that all functions will always be available.

 The Wi-Fi connection can only be implemented for secured Wi-Fi networks that support the WPA2 or WPA3 standard. Older encryption methods and open networks are not supported.

Setting Up and Deactivating a Wi-Fi® Hotspot

Depending on the vehicle equipment, the Infotainment system can be used as a Wi-Fi hotspot for Internet access for up to eight mobile devices, e.g. tablets.

To enable the Infotainment system to be used as a Wi-Fi hotspot, an Internet connection is required, e.g. via the eSIM in the

vehicle or via the hotspot of a mobile device ⇒ [Setting up the Internet connection](#).



The possible types of Internet connections depend on the country and the Infotainment system being used.

Determining network information

Requirements



- ✓ Your vehicle has been added to your VW Car-Net® account.
 - ✓ You have paid for a data plan for your vehicle.
1. Log in to your Volkswagen user account via the VW Car-Net® app or the VW Car-Net® portal and select the vehicle.
 2. Select the network name (SSID) and network key (password) for the vehicle as follows:
 - In the VW Car-Net® portal, under Users ► Wi-Fi SSID and password.
 - Or:** in the VW Car-Net® app, under Users ► Wi-Fi ► SSID & password.

Connecting to Wi-Fi

1. In the app overview, tap  ► Wi-Fi ► Infotainment system as hotspot.
Or: in the app overview, tap Settings  ► Wi-Fi ► Infotainment system as hotspot.
2. Tap Use as hotspot and activate it.
3. Search for available networks on the cell phone.
4. Select from the network names (SSID).
5. Enter and confirm the network key.

The Wi-Fi connection will be established. If necessary, you may need to enter additional information on the cell phone in order to complete the connection.
6. *Optional:* repeat the process to connect additional cell phones.

Deactivating a Wi-Fi Hotspot

1. In the app overview, tap  ► Wi-Fi ► Infotainment system as hotspot.
Or: in the app overview, tap Settings  ► Wi-Fi ► Infotainment system as hotspot.
2. Tap Use as hotspot and deactivate it.

Quick connection

Quick connection with the Infotainment system

The quick connection function can be used to quickly and easily establish an encrypted Wi-Fi® connection. In certain countries, the quick connection can alternatively be established by scanning in a QR code®.

Requirements

- ✓ The mobile device supports WPS or a suitable app for scanning QR codes is installed on the mobile device.
1. In the app overview, tap  ► Wi-Fi ► Quick connection to infotainment system.
 2. Activate WPS on the mobile device.

Or: scan the QR code® in the Infotainment system with the mobile device.

The Wi-Fi connection will be established. It may be necessary to make further inputs on the mobile device in order to complete the connection.

Technical Properties

The technical properties of the vehicle's Internet connections listed below depend on the vehicle equipment and are only

available in some countries.

- Wi-Fi® according to IEEE 802.11 a/b/g/n/ac.
- 2.4 GHz and 5 GHz data transfer.
- Up to eight mobile devices can be connected at the same time.
- Internet connection via Wi-Fi:
 - Tethering via cell phone.
 - Hotspot for clients in the vehicle.
- Apple CarPlay® via Wi-Fi.
- Android Auto® via Wi-Fi.
- Simplified pairing process via QR code®.

Possible data connection types

The available types of possible data connections depend on the vehicle equipment and are only available in some countries.

Mobile device: Use the Wi-Fi hotspot on a mobile device ⇒ [Setting Up and Deactivating a Wi-Fi® Hotspot](#).

eSIM (embedded SIM): The vehicle has a control module with installed SIM card (eSIM). In order to use the Wi-Fi hotspot, you need to purchase data plans via the In-Car Shop or via the web shop of Volkswagen's external mobile network provider.

Requirements

- ✓ Network settings ► Allow Internet connection is activated in the settings menu.
- Or: Data connection ► Integrated data connection is activated.

App-Connect

Introduction

App-Connect makes it possible to display and control content and functions displayed on the cell phone through the Infotainment system screen.

To do this, the cell phone must be connected to the Infotainment system via a USB interface with a data transfer function.

Some technologies can also be used with App-Connect Wireless via the Bluetooth interface and a Wi-Fi hotspot for the Infotainment system.

The following technologies may be available:

- Apple CarPlay®.
- Apple CarPlay® Wireless.
- Android Auto®.
- Android Auto® Wireless.

The technologies listed above are operated by third parties and provided by Volkswagen. Volkswagen is not responsible if these technologies are canceled, discontinued or deactivated during the service life of the vehicle. Apps from third-party providers may be incompatible. It cannot be guaranteed that the apps that are offered will be able to run on all cell phones and with all operating systems.

Which App-Connect technologies are available to you depends on the country and on the cell phone in use. Apps can be based on many different designs and can also differ depending on the vehicle and country. The content, scope, and providers of the apps may vary. Furthermore, some apps depend on the availability of services from third party providers.

You can find more information on the Volkswagen website.

 The use of apps and the required mobile phone connection may be subject to additional charges.

WARNING

Using apps while driving can distract from traffic. Driver distraction can cause serious accidents and fatal injuries.

- Always drive attentively and responsibly.



WARNING

If unsuitable apps are used or apps are not used correctly, this may result in vehicle damage and accidents with serious or even fatal injuries.

- Protect the cell phone and its apps from misuse.



 Volkswagen is not responsible for vehicle damage that is caused by low-quality or malfunctioning third-party apps, inadequate programming of third-party apps, insufficient network strength, data loss, misuse of mobile devices, or malware on data carriers, computers, tablets and cell phones.

Symbols

 Please read the introductory information and heed the Warnings and Notice ⇒  *Introduction*.
The symbol display depends on the vehicle equipment and the country.

 or  Show further information.  Select Apple CarPlay® technology.  Select Android Auto® technology.

Connecting a cell phone with App-Connect

 Please read the introductory information and heed the Warnings and Notice ⇒  *Introduction*.

In order to use App-Connect or App-Connect Wireless, connect the cell phone with the Infotainment system in the app overview via App-Connect. When using App-Connect Wireless, the connection is initiated via Bluetooth and then established via the Wi-Fi hotspot of the Infotainment system.

 As long as a cell phone is connected via App-Connect, no further cell phones can be used via the Infotainment system, e.g. for phone calls via the Bluetooth phone interface.

 When using Apple CarPlay, the Bluetooth connection is disconnected again when the connection via the Wi-Fi hotspot for the Infotainment system is established. When using Android Auto, the Bluetooth connection remains active.

Connecting the cell phone via USB cable

1. For App-Connect, connect the cell phone to the Infotainment system via USB cable.
2. Allow the Infotainment system the required access. To do this, confirm authorization requests on the cell phone.

App-Connect is set up.

Connecting a Cell Phone for App-Connect Wireless

1. For App-Connect Wireless, connect the cell phone with Bluetooth ⇒ *Bluetooth® interface*.

2. Tap   .

Or: tap **(MENU)**  .

Or: press **(APP)**.

3. Select the cell phone and your preferred technology.

4. Allow the Infotainment system the required access. To do this, confirm authorization requests on the cell phone.

App-Connect Wireless set-up is complete.

If any pop-up menus were dismissed during the connection process, App-Connect or App-Connect Wireless will not be available. In this case, Volkswagen recommends deleting the devices from the cell phone settings and Infotainment system and restarting the connection process.

Apple CarPlay®

📖 Please read the introductory information and heed the Warnings and Notice ⇒  [Introduction](#).

Requirements

The following requirements must be met in order to use Apple CarPlay:

- ✓ The iPhone must support Apple CarPlay.
- ✓ The voice assistant (Siri) must be activated on the iPhone.
- ✓ Apple CarPlay must be activated in the iPhone settings without restrictions.
- ✓ For Apple CarPlay Wireless, Bluetooth® and the Infotainment system must be activated on the iPhone as a Wi-Fi® hotspot.
- ✓ If Apple CarPlay Wireless cannot be used, the iPhone must be connected to the infotainment system via a USB connection with data transfer. Only USB ports with data transfer are suitable for use with Apple CarPlay®.
- ✓ The USB cable used should be a USB cable certified and approved by Apple, e.g. the original Apple cable, or one from the Genuine Volkswagen Accessories.

 These technologies may not be available in all countries.

 Information on technical requirements, compatible iPhones, certified apps and availability can be found at the Volkswagen and Apple CarPlay website or at an authorized Volkswagen dealer or authorized Volkswagen Service Facility.

Opening Apple CarPlay



1. To open the App-Connect main menu, tap App-Connect  in the app overview.

Or: press .

2. To start Apple CarPlay, tap  Apple CarPlay.

Disconnecting

1. Tap  in Apple CarPlay mode to open the App-Connect main menu.

2. To end the active connection, tap  or .

The presentation of the function keys in the display may vary.

Special conditions

During an active connection with Apple CarPlay, the following conditions apply:

- For an iPhone connected with the Infotainment system via Apple CarPlay, phone functions can only be accessed via Apple CarPlay.
- The connected iPhone cannot be used as a media device in the Media main menu.
- It is not possible to use the internal navigation and Apple CarPlay navigation at the same time. The route guidance which was started last ends the previous active one.
- Depending on your Infotainment system, you can view information about telephone operation in the instrument cluster display.

- Depending on your Infotainment system and the navigation app used, you can view upcoming turns in the instrument cluster display.
- You can accept or decline incoming calls or end a call in progress using the buttons on the multi-function steering wheel.



Voice assistant

The availability of the “voice assistant” function depends on the vehicle equipment.

1. Tap  briefly to start the Infotainment system IDA voice assistant.

Or: to start the voice assistant (Siri) on the connected iPhone, tap and hold .

Android Auto®

 Please read the introductory information and heed the Warnings and Notice ⇒  [Introduction](#).

Requirements

The following requirements must be met in order to use Android Auto:

- ✓ The smartphone must support Android Auto.
- ✓ For Android Auto Wireless, Bluetooth® must be activated on the smartphone and in the Infotainment system. The Infotainment system must also be activated as a Wi-Fi® hotspot.
- ✓ If Android Auto Wireless cannot be used, the smartphone must be connected to the Infotainment system with a USB connection that allows data transfer. Only USB ports with data transfer are suitable for use with Android Auto.
- ✓ Use a USB cable certified and approved by the smartphone manufacturer or a USB cable from the Genuine Volkswagen Accessories.

 These technologies may not be available in all countries.

 Information on technical requirements, compatible smartphones, certified apps and availability can be found on the Volkswagen and Android Auto websites or at an authorized Volkswagen dealer or authorized Volkswagen Service Facility.



Starting Android Auto

1. To open the App-Connect main menu, tap  in the app overview.

Or: press .

2. Tap  Android Auto to establish the connection with the smartphone.

Disconnecting

1. Tap Close  in Android Auto mode to open the App-Connect main menu.
2. Tap  to end the active connection.

Special conditions

During an active connection with Android Auto, the following conditions apply:

- An active Android Auto device can also be connected with the Infotainment system via Bluetooth (hands-free profile, HFP) at the same time.
- Phone functions are possible through Android Auto. The Infotainment system phone function can also be used if the Android Auto device is connected to the Infotainment system via Bluetooth at the same time.
- An active Android Auto device cannot be used as a media device in the Media main menu.
- It is not possible to use the internal navigation and Android Auto navigation at the same time. The route guidance which was started last ends the previous active one.
- You can view information about telephone operation in the instrument cluster display.

- Depending on your Infotainment system and the navigation app used, you can view upcoming turns in the instrument cluster display.
- You can accept or decline incoming calls or end a call in progress using the buttons on the multi-function steering wheel.

Voice assistant

The availability of the “voice assistant” function depends on the vehicle equipment.

1. Tap  briefly to start the Infotainment system IDA voice assistant.

Or: to start the voice assistant of the connected smartphone, tap and hold .

myVW with Connected Features by Car-Net®

Information about online services

Introduction to VW Car-Net®

myVW makes life even easier in your VW because the mobile myVW app gives you direct access to all of the key functions and information. For example, you can use the myVW app to remotely connect to your vehicle, provided that you have activated VW Car-Net®.

In order to use the mobile online services, you need a subscription to them and to consent to the General Terms and Conditions and Terms of Use. The availability of services and functions is dependent on the country and the vehicle equipment. Certain services or functions can only be used in conjunction with the latest software version.

Some services, e.g. information call, are offered by third-party providers. Additional charges may apply. Further information is available at ⇒ [Information Call, Roadside Assistance Call and Emergency Call Service](#) .

You can find information about how to create a Volkswagen user account, current functions and how to download the app at:

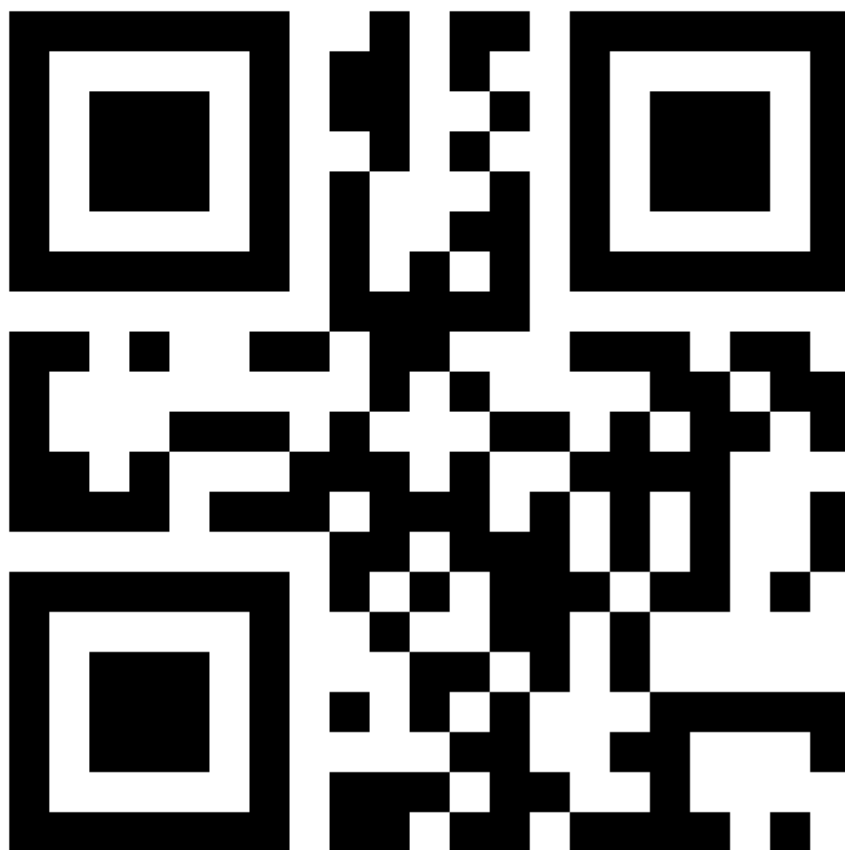

Legal regulations

When using services, vehicle information is sent and processed online. Volkswagen collects, processes, shares and transmits information about you and your vehicle in compliance with the VW Car-Net® terms and conditions and privacy provisions. This data can provide indirect information about the respective driver, e.g. regarding vehicle handling. For further information, please contact the Volkswagen Response Center on 1-833-648-2735. Calls may be monitored or recorded. Or visit our website:

vw.com/carnet

You can find the privacy policy and also further legal information regarding the use of Volkswagen's mobile online services in the app overview under Legal.

Permanent transfer of the vehicle

If the vehicle has been purchased used or if the vehicle has been permanently transferred to you, online services may already be activated and the previous user may be able to view data acquired by online services and control certain functions of your vehicle.

You can see in the Infotainment system if your vehicle is assigned to a person as a primary user. In this case, you can register yourself as the primary user of the vehicle, which automatically removes the previous primary user.

If you sell your vehicle or permanently transfer it to a third party or terminate your leasing contract, you must delete the vehicle from your Volkswagen user account. Volkswagen may continue to send you information about services by sending messages directly to the vehicle. If you do not notify Volkswagen about the sale of your vehicle, its permanent transfer to a third party or the termination of a leasing contract, Volkswagen may continue to send messages directly to the vehicle. Volkswagen shall not be responsible for any damage that could arise due to continuing communication with the vehicle if you do not notify Volkswagen about its sale, its permanent transfer to a third party or the termination of the leasing contract.

Prerequisites for Using Services

To be able to make full use of the services, the following prerequisites must be met.

- ✓ The vehicle is prepared for use of the online services.
- ✓ The vehicle and user are in the area of use.
- ✓ There is a valid contract for use of the services.
- ✓ A personal Volkswagen user account, Volkswagen ID, has been set up.
- ✓ A vehicle has been added to the Volkswagen user account.
- ✓ You have consented to the General Terms and Conditions and the Terms of Use.
- ✓ It is possible to transfer data at the user's location and the vehicle's location without restrictions.
- ✓ A mobile network connection and a GPS signal are available.
- ✓ The mobile device is compatible with the myVW app.
- ✓ The settings on the mobile device allow data to be transferred for services.
- ✓ Neither the Onboard Connectivity Unit nor individual services are deactivated or disabled.
- ✓ Certain technologies operated by third parties and provided to Volkswagen AG are available. Volkswagen AG is not responsible if these technologies are canceled, discontinued or deactivated during the service life of the vehicle.

 The vehicle added to the Volkswagen user account must first be driven a few kilometers before individual services can record, send and display correct data.

 Do not share your login details, password, registration code and S-PIN with others, keep them safe from unauthorized access and ensure that they are not seen by others. Change your password on a regular basis.

Situations that can affect system functions

Even if requirements for the usage of these services have been met, the performance of Volkswagen services may be impaired or blocked by various factors that are outside of the control of Volkswagen. In particular, this includes:

- Maintenance, repairs, deactivations, system updates, and technical improvements to the telecommunications systems, satellites, servers, and databases.
- Malfunction, impairment, or interruption of the mobile network and GPS reception, for example due to high speeds, solar storms, weather conditions, regional circumstances, malfunctioning equipment, and high mobile network usage in the applicable radio cells.
- If you are in a location with no or very poor cell phone or GPS reception. These locations may include tunnels, areas between tall buildings, parking garages, underpasses, mountains, and valleys.

- Limited availability of information or incomplete or incorrect information from third-party providers, such as on map displays.
- In countries, federal states and regions where online services are not offered.

Services That Do Not Require Activation

The following services can still be used if the vehicle has not been added to a Volkswagen user account.

This is the maximum scope possible. Not all services are available in all vehicles and countries.

- Emergency Call Service ⇒ [Information Call](#), [Roadside Assistance Call](#) and [Emergency Call Service](#) .

Setting Up Volkswagen ID

Volkswagen ID offers personal access to Volkswagen's digital world. The Volkswagen ID enables users to log in to Volkswagen apps and websites.

To use the services, you will need a Volkswagen ID. You can register with Volkswagen ID via the myVW app (hereafter referred to as "app").

Registration via the App

1. Install the app.
2. Follow the instructions in the app.

Changing and Deleting Volkswagen ID User Data

You can change or delete the Volkswagen ID data in the app. Any changes to your login details will also apply to all other Volkswagen systems that use Volkswagen ID at the same time.

Managing Vehicles

After you have set up your Volkswagen ID and created your Volkswagen user account in the process, you must add your vehicle to your Volkswagen user account using the 17-digit vehicle identification number (VIN). You will be prompted to do this during the creation of your Volkswagen user account. Once your vehicle has been added to your Volkswagen user account, you can activate online services.

Adding Further Vehicles via the App

1. Start the app and open the vehicle overview.
2. To add another vehicle, tap .
3. Enter or scan the VIN and confirm.

The added vehicle is listed in the vehicle overview.

Removing a Vehicle via the App

 If you remove the vehicle with which you are registered in your vehicle as a primary user, this is the same as resetting the user management to factory settings. All users are deleted in the vehicle, and lose the rights assigned to their respective role to use online services.

1. Open the vehicle overview and tap Delete vehicle or Remove vehicle.

Setting, Changing and Resetting the S-PIN

In addition to the password, the security pin (S-PIN) will also be requested during user authentication. This acts as a second level of security and protects security-related services against unauthorized access.

The security PIN, S-PIN, is a sequence of several numbers that you can freely select as part of registration for online services.

When creating your S-PIN, avoid numbers that are easy to guess and widely known dates of birth. You must keep your S-PIN strictly confidential. For security reasons, you should change your S-PIN immediately if your S-PIN becomes disclosed to a third party.

Setting the S-PIN

 You must have added your vehicle to your Volkswagen user account before you set or change the S-PIN.

- During the registration process, you will be prompted to set the S-PIN in your Volkswagen user account.

 The S-PIN should consist of four non-identical, non-consecutive (neither ascending nor descending) numbers.

Changing the S-PIN

 To change your S-PIN, you must enter and confirm both the previous and the new S-PIN.

- On the app, you can change your S-PIN in your user profile.

 If you enter the S-PIN incorrectly multiple times, the input field will be locked for a period of time.

Getting Help

There are various sources of information for getting help with the function and use of individual services.

You can find answers to frequently asked questions on the Volkswagen websites in the FAQs area.

www.carnet.vw.com

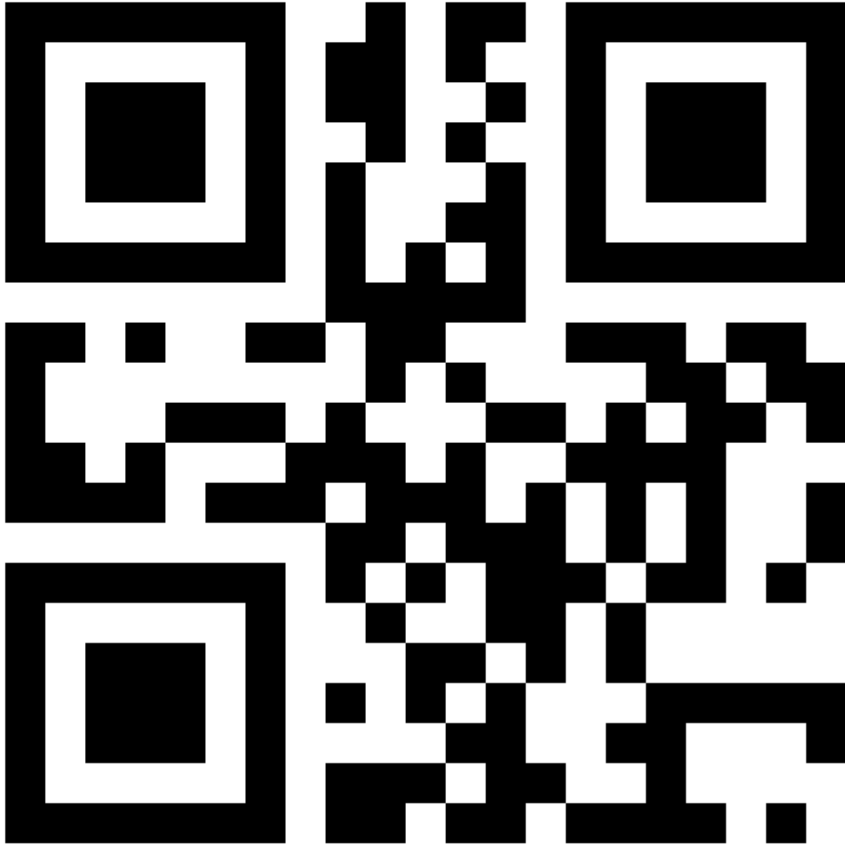

Infotainment system

First steps

Introduction

The functions and settings of the Infotainment system depend on the vehicle equipment and are not available in all countries.

Prior to the first use

Before using the Infotainment system for the first time, read the following points to be able to fully use the available functions and settings:



- Observe the safety instructions ⇒ [Safety instructions](#).
- Reset the Infotainment system to factory settings ⇒ [Operating the Infotainment system](#).
- Refer to the chapter on vehicle interior maintenance for instructions on cleaning the Infotainment system screen ⇒ [Care and cleaning of the vehicle interior](#).
- Find your favorite radio stations, also referred to in the following as "stations", and save them to storage locations to quickly access them ⇒ [Radio](#).
- Only use suitable audio sources and data carriers ⇒ [Media](#).
- Use current map data for the navigation system.
- Pair a cell phone in order to use the phone interface to make calls ⇒ [Mobile phone interface](#).
- Register for the mobile online services to use the relevant services ⇒ [@](#).

Other applicable documents

In addition to this manual, please refer to the following documentation when using this Infotainment system and its components:

- Supplements to your Owner's Manual.
- Operating instructions for the cell phone or audio sources.
- Operating instructions for external data carriers and players.
- Instructions for retrofitted or additional Infotainment accessories.
- Digital instructions in the Infotainment system, depending on the vehicle equipment and not available in all countries.

Safety instructions

 Refer to ⇒  and .

Some functions may contain links to websites that are administered by third parties. Volkswagen does not assume ownership of third-party sites reached through links and is not responsible for their content.

Some functions may contain third-party information that originates from third-party providers. Volkswagen is not responsible for the accuracy, currentness, and completeness of this non-proprietary information, and for ensuring that the rights of third parties are not violated.

The radio stations and owners of the data carriers and audio sources are responsible for the transmitted content.

Parking garages, garages, underpasses, tunnels, high buildings, mountains and valleys and any other electrical devices being used, e.g. battery chargers, may interfere with the reception of cell phone, GPS and radio signals.

Foil stickers or stickers with a metal layer placed on the antenna and on the windows can impair radio reception.

Read and follow the applicable manufacturer's operating instructions when using cell phones, data carriers, external devices, and external audio and media sources.

WARNING

The Infotainment system's central processor is networked with the control modules installed in the vehicle. If the central processor is incorrectly repaired, removed or reinstalled, there is an increased risk of accident and injury due to the control module functioning incorrectly or not functioning at all.

- Never replace the central processor with a used central processor from a scrap vehicle or from recycling.
- Always have the central processor repaired, removed and reinstalled by suitably qualified professionals. Volkswagen recommends contacting an authorized Volkswagen dealer or authorized Volkswagen Service Facility.

WARNING

Reading information on the screen, operating the Infotainment system and connecting, inserting or removing a data carrier or audio source while driving can distract from traffic. Displays and information on the screen may be difficult to read if the lighting conditions are unfavorable or if the screen is damaged or dirty. This may distract the driver from the traffic situation. Driver distraction can cause accidents and injuries.

- Always drive attentively and responsibly.

WARNING

Setting the volume too high prevents you from hearing audible signals. Failure to hear audible signals from outside the vehicle can lead to accidents.

- Adjust the volume settings in the Infotainment system so that audible signals from outside the vehicle (such as sirens on emergency service vehicles) can still be heard.

WARNING

Setting the volume too high can cause hearing damage even if you are exposed to a loud volume for only a short time.

- Select a volume that is at a comfortable level for all vehicle occupants.
- Avoid excessive volume levels.

WARNING

Sudden volume fluctuations can distract the driver, e.g. when an audio or media source is connected or changed. This could cause accidents and injuries.

- Reduce the volume level before changing or connecting an audio or media source, for example.

WARNING

The following conditions may restrict, interrupt or prevent emergency calls, phone calls and data transfers:

- The emergency call location is in an area with no cell phone and satellite reception, or insufficient reception.
- You are in a location where there is sufficient mobile phone and satellite reception, but the telecommunications provider's mobile communications network is unavailable.
- The vehicle components required for emergency calls, phone calls and data transfers are damaged, do not work or

do not have sufficient power.

- The cell phone battery is empty or has an insufficient charge level.

WARNING

Radio stations can broadcast messages about disasters and dangers. If messages about disasters or dangers are not received or issued, accidents and injuries may occur. It may not be possible to receive or send messages under the following conditions:

- The current location is in an area with no cell phone or insufficient radio signal reception.
- In areas with sufficient radio signal reception, where the radio station's frequency bands are malfunctioning or not available.
- The speakers and the vehicle components required for radio reception are damaged, do not work or do not have sufficient power.

WARNING

In some countries and mobile networks, emergency calls can only be made under the following conditions:

- A cell phone with an unlocked SIM card and sufficient calling credit is connected to the vehicle's phone interface.
- Adequate network coverage is available.

WARNING

If a cell phone or CB radio is used inside the vehicle without connection to an outside antenna, the limit values for electromagnetic radiation inside the vehicle may be exceeded and endanger the health of all vehicle occupants.

- Keep the cell phone antenna at least 20 cm (approximately 8 inches) away from any active medical implants, such as pacemakers, because cell phones can impair the function of active medical implants.
- Do not carry a cell phone that is turned on directly above or in the immediate vicinity of any active medical implants, for example by keeping a phone in a shirt pocket.
- Immediately switch off cell phones if you suspect they could impair an active medical implant, e.g. pacemaker, or other medical device.

WARNING

Loose, unsecured or incorrectly mounted cell phones, external devices and accessories can be thrown through the vehicle interior in the event of sudden driving or braking maneuvers or a collision. This can cause accidents and serious injuries.

- Secure or stow cell phones, external devices and Genuine Volkswagen Accessories safely outside of the airbags' deployment zones.
- Always secure or store cell phones, external devices, audio sources and accessories in the dedicated compartments and holders in the vehicle so that they cannot be thrown through the vehicle interior and cannot impede the driver.
- Never leave heavy, hard or sharp objects in the pockets of clothing.
- Arrange cables for external devices and audio sources so that they are not in the way of the driver.

WARNING

Driving recommendations and traffic signs displayed in the navigation system may differ from the actual traffic situation and you must not be tempted to take safety risks.

- Always drive attentively and be ready to intervene at any moment.
- Always bear in mind that traffic signs, signal systems, traffic regulations and local circumstances have priority over the driving recommendations and displays in the navigation system.
- Always adapt your speed and driving style to the current visibility, weather, road and traffic conditions.

NOTICE

Radiation from cell phones that are switched on can interfere with sensitive technical and medical devices, potentially causing malfunctions or damage to the devices.

- Always switch off the cell phone in areas with special regulations relating to or prohibiting the use of cell phones.

NOTICE

Setting the volume too high and excessively loud or distorted playback can damage the speakers.

- Select the volume setting so that the speakers are not damaged.

User information

 Refer to  and  *Safety instructions*.

The Infotainment system requires a few seconds to perform a complete system start, and will not respond to inputs during the time. During the system start, only the Rear Assist camera can be displayed.

The Infotainment system must start completely before all displays can appear and functions can be performed. The length of time that it takes for the system to start depends on the scope of functions in the Infotainment system, and it can take longer to start at low and high temperatures.

Observe local regulations and legal requirements when using the Infotainment system and corresponding accessories, such as headphones.

For the Infotainment system to function, it must be switched on and the vehicle must be set to the current date and time if necessary.

A missing function key in the screen is not the result of a device error, but instead corresponds to the country-dependent equipment.

Some Infotainment system functions can only be selected when the vehicle is stationary. In some countries, the selector lever must also be in the **N** or **P** selector lever position. This is not a malfunction, but rather compliance with legal regulations.

Some countries may have restrictions regarding the use of Bluetooth® devices. Information can be obtained from the local authorities.

If the 12 V vehicle battery has been disconnected, switch on the ignition before switching on the Infotainment system.

Displays on the screen may vary due to differences in the settings, and the Infotainment system may function differently than described in this manual.

The Infotainment system will switch off automatically when the engine stops and if the 12 V vehicle battery charge level is low

In some vehicles with a parking system, the volume of the current audio source may be automatically lowered when you shift into reverse. The volume reduction can be adjusted.

The Infotainment system contains information about the software contained in the system and the licensing conditions: depending on the vehicle equipment, it can be found under Settings ► Info or Settings ► System information, Settings ► Copyright and Settings ► License information.

If you sell or loan your vehicle to someone, ensure that all of the saved data, files and settings are deleted and, if necessary, that the external SD card, the external audio sources and any data carriers are removed.

Some functions in the Infotainment system require an active Volkswagen user account for the vehicle for the mobile online services and a connection to the Internet ⇒ *Data transmission*, ⇒ ®. In order to enable functions to be carried out, data transfer must not be restricted.

Brands, licenses, copyright

Refer to ⇒  and  *Safety instructions*.

Brands and licenses

Certain terms in this manual have the ® or ™ symbols. These symbols indicate emblems or registered trademarks. However, the absence of this symbol does not constitute a waiver of any rights associated with intellectual property.

Other product names are registered trademarks for the respective rights holder.

- Manufactured under license from Dolby Laboratories. Dolby and the double-D symbol are trademarks of Dolby Laboratories.
- Manufactured under license from Dolby Laboratories. Dolby, Pro Logic and the double-D symbol are trademarks of Dolby Laboratories.
- All SiriusXM services require a subscription. See the SiriusXM Customer Agreement for complete terms at www.siriusxm.com (US) or www.siriusxm.ca (Canada). All fees, content and features are subject to change. Satellite and steaming lineups may vary. SiriusXM, Pandora and all related logos are trademarks of Sirius XM Radio Inc. and its respective subsidiaries. All rights reserved.
- HD Radio™ Technology manufactured under license from iBiquity Digital Corporation, a subsidiary of Xperi Inc., U.S. and Foreign Patents. For patents see <https://xperi.com/hd-radio-patents/>. Xperi, HD Radio, HD, and “ARC” logos and their respective logos are trademarks or registered trademarks of Xperi Inc. and its subsidiaries in the United States and other countries.
- QR Code® is a registered trademark of DENSO WAVE INCORPORATED.
- Apple Music is a trademark of Apple Inc.
- SPOTIFY and the Spotify logo are among the registered trademarks of Spotify AB. Compatible vehicle and Spotify Premium subscription required, where available.
- Android Auto® is a trademark of Google LLC.
- Apple CarPlay® is a trademark of Apple Inc.
- Bluetooth® is a registered trademark of Bluetooth® SIG, Inc.
- iPod®, iPad®, and iPhone® are registered trademarks of Apple Inc.
- MPEG-4 HE-AAC audio coding technology and patents licensed from Fraunhofer IIS.
- SD® and SDHC® are trademarks or registered trademarks of SD-3C LLC in the USA and other countries.
- Windows® is a registered trademark of Microsoft Corporation, Redmond, USA.
- This product is protected by the intellectual property rights of Microsoft Corporation. Use or distribution of such

Copyright

Audio and video files saved on data carriers and audio sources are generally subject to copyright regulations in compliance with applicable international and national laws. Observe legal regulations.

Overview and operation of the Infotainment system

Overview of Infotainment system

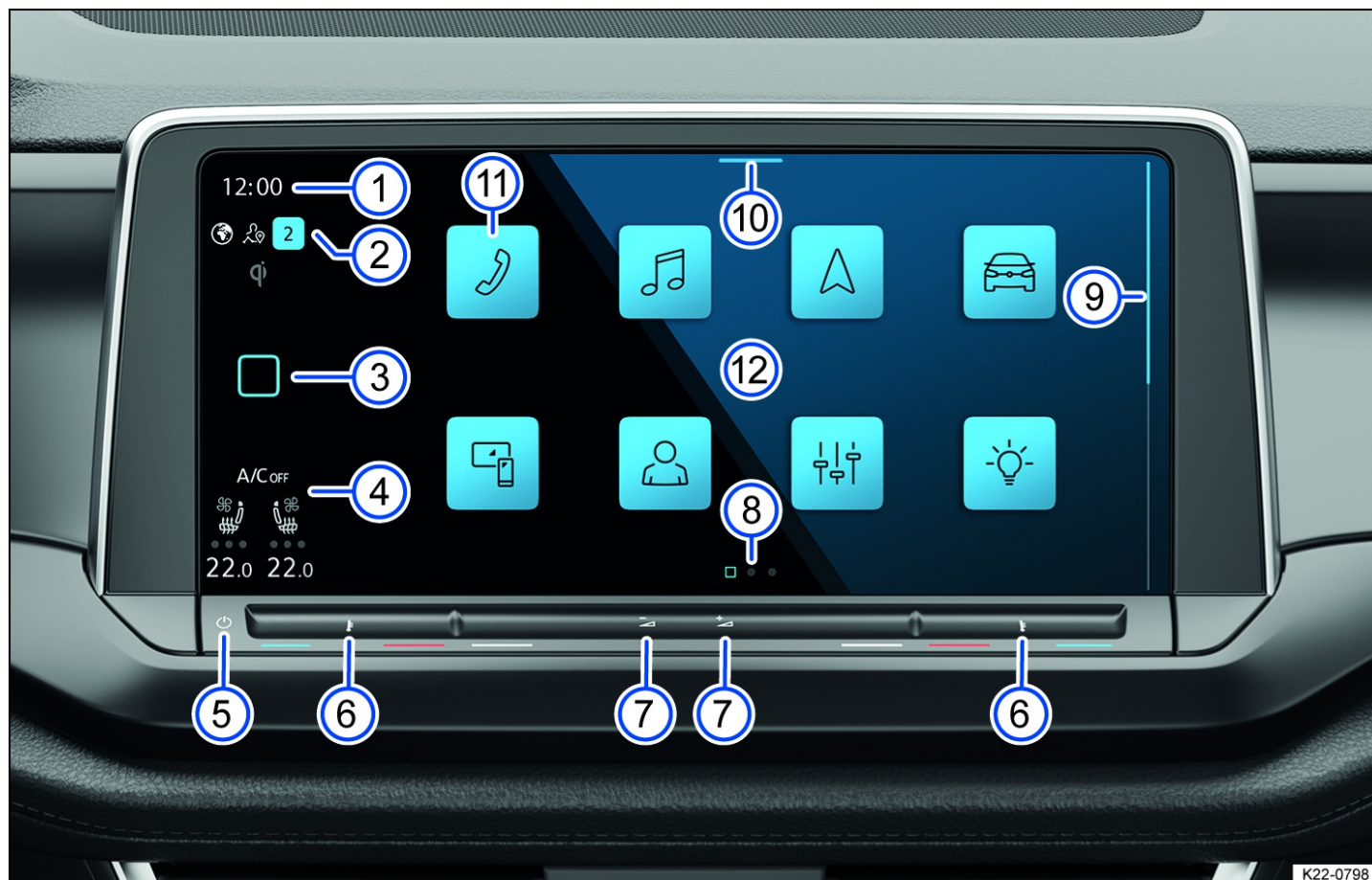

Fig. 129 Overview of the Infotainment system.

- ① Displays the time.
- ② Status display for the “Privacy settings” function (availability depends on the country) and number of notifications.
- ③ Home button: (hereinafter: **HOME**).
- ④ Function key for Air conditioner menu, temperature display (can be adjusted via [fig. 129](#)) and status display for seat heating and seat ventilation (available depending on the vehicle equipment).
- ⑤ Sensor area for switching the Infotainment system on and off.
- ⑥ Touch control for temperature.
- ⑦ Touch control for volume.
- ⑧ Pages.
- ⑨ Scroll bar.
- ⑩ Control Center.
- ⑪ Function key for main menu.
- ⑫ Screen (touchscreen).

3 Home button: (hereinafter: **HOME**)

The home button is hereinafter referred to as **HOME**.

1. To open the app overview, tap **HOME**.

5 Sensor area for switching the Infotainment system on and off

1. Tap the sensor area to manually switch the Infotainment system on or off.

6 Touch control for temperature

Touch control for the driver seat and touch control for the front passenger seat.

- Swipe left to reduce the temperature.
- Swipe right to increase the temperature.

7 Touch control for volume

- Swipe left to reduce the volume.
- Swipe right to increase the volume.

8 Pages

Certain menus and functions have multiple pages with different content. The current page is highlighted.

- Tap a selection to switch to a page.
- To switch between pages, swipe left or right on the screen.

9 Scroll bar

Certain menus and functions contain additional content above and below the content currently displayed on the screen.

1. Tap the scroll bar and swipe down or up to display additional content.

10 Control Center

The control center contains additional function keys for functions and notifications. Displayed functions can be configured ⇒ [Personalizing the Infotainment system](#).

1. Tap the selection and swipe down to open the control center.



11 Function key for the main menu

You can configure the position of the function keys ⇒ [Personalizing the Infotainment system](#).

1. To open a main menu, tap the corresponding function key e.g.  for the phone interface.

12 Screen (touchscreen)

You can operate the Infotainment system functions via the screen. The screen brightness can be adjusted via the control center [fig. 129](#) . You will find detailed explanations of the different finger movements in the digital manual for the Infotainment system, if available ⇒ [Operating the Infotainment system](#).

1. To open the digital manual for the Infotainment system, tap **HOME** ▶  ▶ .

Gesture control (without position numbers)



The gesture control can also be switched on. If gesture control is switched on, this is shown on the screen.



1. Tap **HOME** ▶  ▶ Screen ▶ Hand gesture.

Operating the Infotainment system

Restoring the Infotainment System to Factory Settings

1. Open the app overview and tap Settings ► Restore factory settings.

 Pay attention to the information about VW Car-Net® ⇒ .

 When restoring factory settings, the vehicle settings are deleted, and personal data may also be deleted. Mobile online services can no longer be used in this vehicle. The services can only be used again after reactivation. If there is a primary user in the vehicle, they will also be deleted and informed of this via e-mail. Please note additional information on this in the chapter on the mobile online services ⇒ .

Opening the Quick Guide to the Infotainment System (if available)

Further information and tips on operation can be found in the quick guide to the Infotainment system.

1. Open the app overview and tap  ► .

Switching the Infotainment System On or Off

In the following case, the Infotainment system switches on automatically:

- If the Infotainment system was not previously switched off manually, it will switch on when the ignition is switched on.

The Infotainment system starts at the volume that was last set, as long as this does not exceed the preset maximum switch-off volume.

In the following cases, the Infotainment system will switch off automatically:

- If you leave the vehicle while the ignition is not active.
- If you switch on the Infotainment system manually while the ignition is not active, it will switch off after approximately 30 minutes without user input.

If the Infotainment system is no longer responding, it automatically restarts. If restarting does not work, tap the sensor area for switching on and off, or press the dial and pressure switch and hold for approx. 15 seconds.













WARNING

During a restart of the Infotainment system, functions such as the Rear View Camera system display, acoustic and visual warnings of the Park Distance Control and Rear Traffic Alert, the Park Distance Control, the Rear Traffic Alert and other warning tones may not be available for a short time. This can cause accidents and serious injuries.

- Always stay attentive and do not rely solely on the systems. The driver is always responsible for control of the vehicle.
- Pay attention to the traffic situation and the vehicle environment when entering and leaving a parking space.
- In a hazardous situation, apply the brakes using the brake pedal.
- Wait until the Infotainment system and the other systems are fully started.

Main Menus in the App Overview

The following main menus may be included as function keys in the app overview:

 Ambient lighting, Ambient light ⇒ *Interior/reading lights, ambient lighting*.  App-Connect ⇒ *App-Connect*.  Assistance systems ⇒ *Driver assistance systems*.  Vehicle ⇒ *Driver information*.  Help: Here, you can find additional information about Infotainment system functions and operation, e.g. the quick guide.  Sound ⇒ *System and sound settings*.  Climate control ⇒ *Heating and air conditioning system*.  Navigation ⇒ *Navigation*.  Radio/Media ⇒ *Radio, ⇒ Media*.  Legal.  Setup ⇒ *System and sound settings*.  Telephone ⇒ *Mobile phone interface*.

Configuring the App Overview

In the app overview, you can configure the layout of the function keys, pages and displays or have them positioned using standard layout templates.

1. Open the app overview.
2. Tap the function key and hold until the function key is highlighted.
3. Move the function key to the preferred position and release it.

Personalization

Depending on the vehicle equipment, you can personalize function keys and pages ⇒ [Personalizing the Infotainment system](#).





Personalizing the Infotainment system

Depending on the vehicle equipment, you can personalize the Infotainment system to access your favorite and frequently used functions quicker.

The Infotainment system pages contain tiles for accessing additional menus and functions.

Configuring tiles



Configure the tiles by removing or adding pages.

1. Tap **HOME**.
2. Tap and hold tiles until an additional window appears.
3. To open the configuration screen, tap .
 - To add a new view with tiles, tap  and tap on the desired template. New tiles are created without any functions.
Or: to delete a view with tiles, tap .
4. Tap  to close the configuration screen.
5. To return to View, tap  or tap any free area of the screen.

 There are always at least two pages available. These pages cannot be removed. Depending on the vehicle equipment, you can add two further pages. A maximum of four pages can be displayed.

Adjusting tiles

Adjust the tiles and displayed tile functions in the Infotainment system pages in order to manage the Infotainment system as you wish.

1. Tap **HOME**.
2. Tap and hold tiles until an additional window appears.
3. To add functions to a tile, tap on the desired tile.
4. Tap the desired function in the additional window. Various functions are available depending on the size of the tile.
5. To remove a function from a tile, tap on the desired tile and tap .
6. To return to View, tap  or tap any free area of the screen.

 For some tiles, more functions are available than can be seen initially in the additional window. Swipe to the left or right in the additional window to see all the functions.

Adjusting the control center

Adjust the Infotainment system Control Center for quicker access to your favorite and frequently used functions.

1. Open the Control Center.
2. Tap and hold the function until an additional window appears.
3. Tap the desired function in the additional window and hold until the function is highlighted.
4. Move the function to the preferred position and release it.

The active function is automatically removed from the control center and added to the additional window.

 For the control center, more functions are available than can be seen initially in the additional window. Swipe to the left or right in the additional window to see all the functions.

Opening personalization tips (if available)

Further information and tips on personalization can be found in the digital manual for the Infotainment system.













1. Tap    Adjustment.

System and sound settings

Changing settings

The meanings of the following symbols apply to all system and sound settings.

Changes will be automatically applied when the menu is closed.

,  or  The setting is selected and activated or switched on. ,  or  The setting is not selected and deactivated or switched off.  or  Open the drop-down list.  Increase the set value.  Reduce the set value.  Go back stepwise.  Go forward stepwise.  Use the slide control to continuously change the set value.

System settings

The system settings may include the following functions, information, and setting options:

- Restore factory settings.
- Screen.
- Copyright.
- Data connection.
- Units.
- Configuration assistant.
- Mobile devices.
- Voice control.
- Language.
- System information.
- Time and date.
- Wi-Fi®.
- Additional keyboard languages.

Opening system settings

1. Tap  Setup.

Sound settings

The sound settings may include information and setting options for equalizer, position, volume and setup.

Opening sound settings

1. Tap **HOME** ► Sound.

Adjusting the volume of external audio sources

Lower the volume of the Infotainment system before turning up the volume of an external audio source.

If the connected audio source plays too quietly, increase the output volume of the external audio source. If that does not correct the problem, set the input volume to Medium or Maximum.

If the connected external audio source plays too loudly or the sound is distorted, lower the output volume of the external audio source. If that does not correct the problem, set the input volume to Medium or Quiet.

Radio

Introduction

In radio mode, you can receive available radio stations available via various reception modes and save your favorites to enable quick access.

Available reception modes depend on the vehicle equipment and are not available in all countries. Frequency bands and reception modes may be discontinued, switched off or no longer offered in individual countries.

In some countries, depending on the vehicle equipment, you can also use Internet Radio ⇒ [Online Functions](#).

 The radio stations are responsible for transmitted content.

 Other electrical devices connected in the vehicle can impair radio signal reception and cause noise in the speakers.

 Decals or metal-coated stickers on the vehicle windows can impair radio reception in vehicles with window antennas.

Function descriptions

 Refer to ⇒  and  [Safety instructions](#).

Selecting a Reception Mode

Various stations are available, depending on the reception mode. The available reception modes depend on the vehicle equipment and are not available in all countries.

1. To open the list of reception modes, tap Source.
2. Select a reception mode, e.g. FM.

Searching For and Selecting a Station

You can search for and select stations in a variety of ways. The options vary based on the reception mode.



Searching for a Station in SCAN mode

In SCAN mode, the stations in the reception mode are set automatically in succession and played for approx. five seconds each.

1. To start SCAN mode, tap SCAN.
SCAN mode starts and the current station is shown on the display.
2. To select a station, tap SCAN.
SCAN mode stops and the station is tuned.

Selecting a Station Using the Multi-function Steering Wheel

You can select stations from the station list or from favorites via the multi-function steering wheel.

- To select the previous station, press  on the multi-function steering wheel.
- To select the next station, press  on the multi-function steering wheel.

Selecting a Station Using a Frequency Band

1. Select AM or FM reception mode.
2. To open the frequency band, tap .
3. Tap the cursor to press and slide to the frequency band and release at the desired frequency.

Or: tap a point on the frequency band. The cursor automatically jumps to the corresponding frequency.

The station at the set frequency will be tuned.

Selecting a station from the station list

Depending on the vehicle equipment, it is possible that the station list must be manually updated if you have left the area since the last time the station list was opened. In FM/DAB reception mode, the station list generally updates automatically.

1. Select reception mode.
2. Tap the desired station.

The selected station will be tuned.

Selecting a Station and Saving as a Favorite

You can save up to 36 stations or frequencies from different reception modes as favorites.

Saving a Station as a Favorite

1. Select reception mode.
2. Tune the desired station.
3. Tap .

Or: tap and hold the station on the station list.

The storage locations are displayed.
4. Tap .

Or: Tap and hold a storage location that is already occupied until the station is saved.

The station is saved at the selected storage location.

If a station was already saved at the storage location, this station will be removed from the storage location and replaced by the new station.

Other Functions in Radio Mode

The functions listed below are available depending on the vehicle equipment and only in some countries.

Station logos

Station logos can be preinstalled for some frequency bands in the Infotainment system.

If the Automatic selection of station logos or Automatic station logo selection function is activated in the settings, the station logos are automatically assigned to the stations.



In Internet radio mode, the Infotainment system obtains the station logos from an online database and assigns them automatically to the stations.

Activating automatic assignment of the station logos

1. In radio mode, tap  and tap and activate Automatic selection of station logos or Automatic station logo selection.

Assigning station logos manually

In AM reception mode, you cannot assign station logos manually.

1. In radio mode, tap  ► Radio ► Station logos.
2. Select a station to which a station logo is to be assigned.
3. Select the station logo.
4. This process can be repeated for additional stations.
5. To finish assigning station logos, tap .

Functions and Symbols

 Refer to ⇒  and  *Safety instructions*.

Functions



The functions and possible reception modes depend on the vehicle equipment and are not available in all countries.









- AM tuner.
- FM multiple tuner (diversity antenna).
- FM dual tuner (diversity aerial).
- Summarized preset list for favorites.
- Display of station logos.
- Antenna amplifier
- Internet radio.
- HD Radio™.
- Satellite radio:
 - SiriusXM™ 360L.

Symbols









The symbols depend on the vehicle equipment and are not available not in all countries and may look different depending on the Infotainment system.

General symbols





1. To open the main menu, open the app overview and tap  or  ⇒ *Overview of Infotainment system*.

 AM or  Select reception mode AM.  FM or  Select reception mode FM.  Internet Radio Select the Internet Radio reception mode.  SiriusXM Select the Satellite radio reception mode. |  Open an additional window with current playback.  Open the preset list for favorites.





Displayed small in a station list: stations already saved as favorites.

 or  Open the preset list for favorites.  Displayed small in a station list: stations already saved as favorites.  Open the last station from the station list or from favorites.  Open the next station from the station list or from favorites.  Open additional information about the selected station.  or  Opening the settings.

Symbols for the AM Reception Mode









 or  Open the station list for AM stations.  Manually update the station list.  or  Open the frequency band for manually selecting the AM frequency.

Symbols for the FM and, depending on the country, FM/DAB reception modes







 or  Open the station list for the FM stations and, depending on the country, DAB stations.  or  Open the frequency band for manually selecting the FM frequency.

This is only possible if the summarized FM/DAB station list is deactivated in the settings.



Symbols for Internet Radio operation

 Open full-text search.  Unable to receive Internet radio.  Open the Internet radio station that was last listened to.  Open the 100 most popular Internet radio stations.  Open available Internet Radio podcasts.  Open Internet radio stations that originate from the preferred country.  Open Internet radio stations that transmit programs in the preferred language.  Open Internet radio stations whose programs are of the preferred genre.  Open the station selection.

Symbols for HD Radio operation

 Station supports HD Radio.   or  Tune the HD Radio substations.  Open the Emergency List of the “HD Radio Emergency Alerts” function.  HD Radio® HD Radio logo.

Symbols for satellite radio operation

 Open the channel list.  Open the window for entering the channel number.

Online Functions

 Refer to  and  [Safety instructions](#).

Depending on the vehicle equipment, the Infotainment system features online functions in radio mode.

Online functions in radio mode are not available in all countries and vehicle models.

Online functions in radio mode include Internet Radio, for instance.

Prerequisites for using online functions in radio mode:

- ✓ The vehicle is equipped with VW Car-Net®.
- ✓ You have registered and you have an active VW Car-Net® user account.
- ✓ The vehicle is assigned to your VW Car-Net® user account.
- ✓ You have purchased a corresponding active data package for an internet connection and have also purchased a “Plus Online Radio subscription” through the myVW app or via the VW Car-Net® website, USA: vw.com/carnet, Canada: vw.ca.
- ✓ For streaming services, you may need an existing account with the respective provider.

Prerequisites for using online functions in radio mode:

- ✓ The prerequisites for using the services have been met \Rightarrow [Prerequisites for Using Services](#).
- ✓ You have purchased a corresponding data plan for an Internet connection through the In-Car Shop and are connected to your vehicle via the Wi-Fi® hotspot on your cell phone \Rightarrow [Internet use in the vehicle](#).
- ✓ For streaming services, you may need an existing account with the respective provider.

Internet radio

Internet radio is a reception mode for Internet radio stations and podcasts independent of AM, FM and DAB. Due to its transmission over the internet, receipt is not regionally limited. Internet Radio is only available if the Infotainment system has an active Internet connection \Rightarrow [Internet use in the vehicle](#). Costs for streaming data online may result when using Internet radio.

Searching For and Filtering Stations

In Internet Radio mode, stations can be filtered according to category or searched for using a full-text search.

1. Open the station selection.

2. Select the categories by which to filter the stations.

Or: to start the full-text search, tap .

The input line is displayed.

3. Enter the name of the preferred station or the preferred category.

The list of the found stations updates automatically during input.

4. Tap the desired station.

SiriusXM

 Refer to   and  *Safety instructions*.

SiriusXM is a satellite-based radio service that can be received in the USA and Canada.

SiriusXM subscriptions can be activated via cell phone.

The current status of the subscription can be shown in the settings in satellite radio mode.

Additional information can be found on the Internet:

In the USA:

www.siriusxm.com

In Canada:

www.siriusxm.ca

Displaying the SiriusXM ID

Each radio has its own SiriusXM ID with which you can manage your subscription.

1. Select the SiriusXM reception mode.

2. Tap   Help and support.

Or: in radio or media mode: tap   Radio  Help and support.

Or: tap  or  and enter channel number "0".

The SiriusXM ID, the website and phone number for the SiriusXM activation hotline will be displayed on the screen.



SiriusXM with 360L

Your vehicle can be equipped with SiriusXM with 360L. SiriusXM with 360L offers both satellite and streaming connectivity for a multitude of music, news, sports, talk and entertainment channels and content. With SiriusXM with 360L, you have a personalized listening experience with recommendations and functions based on your listening habits.

SiriusXM live channels

The channels available depend on the enabled services. All available channels are displayed in the channel list.

Each channel is assigned a channel number.

The channels are sorted in the channel list according to their channel number. The channels can be opened directly under  or  via their channel number.

All channels are sorted according to categories. Within the categories, the channels are sorted according to genre. Channels can be browsed in categories, e.g. music.



Activating SiriusXM

1. Activate VW Car-Net®  .

2. Follow the instructions in the app.

Playing SiriusXM Live Channels

Available channels can be played in various ways depending on the vehicle equipment.

1. Select the SiriusXM reception mode.
2. Tap ▶ or  and set the desired channel using the channel number.
Or: Tap the title image of the preferred channel.
3. *Optional:* To search for channels with content related to the content currently being played, tap Related in the station display.

A list with related content will be displayed.

On Demand

SiriusXM with 360L offers access to a multitude of on-demand content, e.g. concerts.

Opening on-demand content

1. Select a channel category, e.g. music, and select a genre, e.g. rock.
2. Tap On Demand.
3. *Optional:* To search for on-demand content related to the content currently being played, e.g. shows, tap Related in the station display.

A list with related content that is currently playing will be displayed.

Live Sports

The “Live Sports” category allows you to listen to live transmissions of games and events that are being aired on SiriusXM.

Opening Live Sports

1. Select the category “Live Sports”.
2. Select your desired live game transmission.

Play Ahead Controls

With the “Play Ahead Controls” function, both live and on-demand content can be played and paused, and you can jump forwards or backwards in the playback.



Presets

SiriusXM live channels and on-demand shows can be saved as a preset. Up to 36 presets can be saved.

Saving SiriusXM content as Presets

1. To save a live channel currently being played back or an on-demand show currently being played back as a preset, press and hold a preset bank.

Or: tap ▶.

Or: in the channel list or the list of on-demand shows, press and hold your desired content and tap ▶.

SiriusXM Listening Profile

The personalized listening profile saves recommendations based on the program content currently being listened to and the latest listening history, and is regularly updated.

The listening profile can be set up in the Volkswagen user account and used with the SiriusXM app.

Creating a SiriusXM Listening Profile

1. Select the SiriusXM reception mode.
2. To set up a new listening profile, tap  in the station display.

Or: tap  ► Radio ► Set up new listening profile in radio or media mode.

Personalized SiriusXM recommendations

A collection of personalized SiriusXM recommendations is available for each SiriusXM listening profile.

The personalized SiriusXM recommendations are regularly updated, based on what you're listening to.

Displaying personalized SiriusXM recommendations

1. Tap For You.

Listening history

For each SiriusXM listening profile, a list of SiriusXM content recently listened to is displayed. This listening history can be displayed and reset at any time.

HD Radio

 Refer to  and  [Safety instructions](#).

HD Radio is a digital radio station that can be received in the USA and Canada.

HD Radio Technology

Some AM and FM radio stations also transmit their content digitally via HD Radio Technology.

When the function is activated in settings in the AM or FM band and the current station supports HD Radio Technology, the  function key appears on the Infotainment system display. The Infotainment system switches automatically between digital and analog reception depending on the reception quality. If the station is currently received in analog mode, the function key is grayed out.

Some stations offer additional substations via HD Radio Technology (multicast programming). If this is the case, HD1 is displayed after the station frequency of the main station. Substations are marked with HD2, HD3, etc.

Tuning the HD Radio Substations

1. Tap  to cycle through the available substations.

Or: Select an additional station from the station list.

Or: to cycle through the additional stations individually, tap < or >.

The substation that is currently selected is displayed after the main station on the screen (for example ... HD3 for the second substation).

 The available substations of the current stations are displayed on the station list.

Additional HD Radio Technology services

1. To select your chosen additional service, tap View.

HD Radio Emergency Alerts

The “HD Radio Emergency Alerts” function can be used to receive reports of unusual, potentially life-threatening events, such as natural disasters. These notifications are played as pop-up notifications while the radio is on. This function is activated in the factory.

If you tap Remind me later when a notification appears, the notification will appear again about ten minutes later. If you tap Close, the notification will be moved to the Alert list. If the “HD Radio Emergency Alerts” function is deactivated, these notifications are moved directly to the Alert list and indicated by  and a number in the status bar. The number on the symbol displays the number of notifications.

Activating or deactivating HD Radio Emergency Alerts

1. In radio mode, activate or deactivate  ► Radio ► Emergency notifications.

Opening the Alert list

Up to five notifications can be displayed in the Alert list.

1. Tap  in radio mode.

Media

Introduction

In media mode, you can play back media files from data carriers via the Infotainment system and, depending on the vehicle equipment, save your favorites for quick access.

Depending on the vehicle equipment, the following data carriers can be used as media sources:

- USB storage medium, e.g. USB flash drive.
- Bluetooth device, e.g. cell phone.

Depending on the vehicle equipment, the following types of media files can be played:

- Audio files, e.g. music.

You can also use streaming services, depending on the vehicle equipment and in some countries ⇒ [Online Functions](#).

Restrictions and instructions for data carriers

Dirty, overheated or damaged data carriers are not to be used. Read and heed the information provided by the manufacturer.

Difference in quality between data carriers from different manufacturers can cause problems with media playback.

Wrong configuration of data carriers can lead to the data carriers being unreadable.

The storage volume, condition (copy and delete processes), file system, folder structure and the amount of saved data can increase the time taken to read data carriers.

Playlists only define the order of play and refer to the saved location of the media files within the folder structure. No media files are saved in playlists. To play a playlist, the media files must be present in the data storage device memory location, to which the playlist refers.

 Volkswagen is not responsible for damaged, altered or lost files on data carriers.

Playing a Media File

 Refer to ⇒  and  [Safety instructions](#).

Connecting and Selecting a Media Source

1. Connect the media source.
2. Tap My media and select your preferred media source.

Searching For and Playing Media Files

You can search for and play media files from a media source in a variety of ways.

Searching the Selected Media Source

You can find all of the media files on the connected media source via a folder structure or by using the full-text search.

1. Open the folder structure.
2. Searching the folder structure for a desired track.

Or: to start the full-text search, tap .

The input line is displayed.

3. Enter the name of the desired track.

The list of the found tracks updates automatically during input.

4. Tap the desired track.



When playback starts, if the selection is located in a folder on a media source, all of the media files located in the folder will be added for playback.

If a playlist is played back, all available tracks on the playlist will be added for playback.

5. Close the selection with ✕.

Saving the Media File as a Favorite

Only media files that are saved in My Media in the Music and Video folders can be saved as favorites. You can save individual tracks, albums, artists and genres as favorites.

1. Start playback of the desired track.
2. Tap .
3. Tap .

Or: tap on an already occupied favorite position, and press and hold for approx. three seconds.

4. Select from the selection list:, e.g. title.

The selection options in the selection list depend on the data attached to the media file. If a genre is not indicated for music files, the genre cannot be saved as a favorite.

If a video file is currently being replayed, only this video can be saved as a favorite.

The selection is saved in the selected favorite position as a favorite. If the favorite position was already occupied, the previously saved favorite will be replaced by the selection.

Selecting a Media File from Favorites

1. Tap .
2. Tap on your favorites.

Depending on the selection, all tracks heard during the current playback will be added to favorites.

Entertainment Playback via the Infotainment System

The Infotainment system can play music and videos.

Video mode

In video mode, the Infotainment system display can play a video from a data carrier.

The video sound is played back via the vehicle speakers.

The video image is only displayed when the vehicle is stationary. The Infotainment system display will be switched off when the vehicle is moving. The video sound will continue to be played.

In some countries, for road safety reasons, no video image is shown even when the vehicle is stationary.

Depending on the vehicle equipment and in some countries, video from a streaming service can also be played back ⇒ *Only Functions*. A stable Internet connection is required for playback via a streaming service. There may be costs associated with your mobile network provider for doing so.

Functions and Symbols

 Refer to ⇒  and  *Safety instructions*.

Functions



The functions and possible media formats depend on the vehicle equipment and are not available in all countries.

















- Media playback and media control via Bluetooth.
- Audio playback in these formats:
 - AAC.
 - APE.
 - ALAC.
 - MP2.
 - MP3.
 - Vorbis.
 - OPUS.
 - WMA.
 - WAV.
- Video playback in these formats:
 - MPEG-1 and MPEG-2 (.mpg, .mpeg, .mkv, .avi).
 - ISO MPEG-4 ASP; Xvid (.mp4, .m4v, .mov, .mkv, .avi).
 - ISO MPEG-4 AVC/H.264 (.mp4, .m4v, .mov, .mkv, .avi).
 - Windows Media Video 9 (.wmv, .asf, .mkv, .avi).
- Cross-device playlists.
- Cross-source media database: My media.
 - Data from all media sources connected to the Infotainment system are stored in a media database.
 - If My Media is selected, the categories (e.g. music) and connected media sources are displayed.
 - All media files from USB devices are filtered by category (e.g. albums). This category view is always displayed in My Media. The classic folder structure of the individual USB data carriers can also be found in the My Media menu.
- Media search.
- Media streaming (online).

Symbols

The symbols depend on the vehicle equipment and are not available not in all countries and may look different depending on the Infotainment system.

General symbols

1. To open the main menu, open the app overview and tap   ⇒ *Overview of Infotainment system*.

 Start replay.  Pause replay.  Go to the previous track.  Skip to the next track.  Repeats the current track.  Repeats all tracks.  Activate random playback.  Search current media source (list view).  Close list view.  Add media file to favorites list.  Open the favorites list.  Open the favorites list.  Go back one folder level in the media source.  Go back one folder level in the media source.  or  Opening the settings.

Symbols for media sources









 My media: select cross-source media database My media as the media source. Connected USB devices and their

folder structures may be selected under My media.  Bluetooth: select a device connected via Bluetooth as a media source.



 Set up available streaming services.

Streaming services which have already been set up are represented by their own logos in the list of media sources.

Symbols for categories and groups of media files

 Music tracks.  Videos.  Playlists.  Albums.  Artists.  Genres.  Podcasts.  Audiobooks.

Video replay symbols

 Replay video in full-screen mode.  Minimize replay.

Online Functions

 Refer to  and  [Safety instructions](#).

Depending on the vehicle equipment, the Infotainment system features online functions in media mode.

Online functions in media mode are not available in all countries and vehicle models.

Online functions in media mode include streaming services, for instance.

Prerequisites for using online functions in media mode:

- ✓ The vehicle is equipped with VW Car-Net®.
- ✓ You have registered and you have an active VW Car-Net® user account.
- ✓ The vehicle is assigned to your VW Car-Net® user account.
- ✓ You have purchased a corresponding active data package for an internet connection through the myVW app or through the VW Car-Net® website, USA: vw.com/carnet, Canada: vw.ca.

Prerequisites for using online functions in media mode:

- ✓ The prerequisites for using the services have been met  [Prerequisites for Using Services](#).
- ✓ You have purchased a corresponding data plan for an internet connection through the In-Car Shop or you have sufficient data capacity on your cell phone's SIM card and are connected to your vehicle via the Wi-Fi® hotspot on your cell phone.

Streaming services

Depending on the vehicle equipment and in some countries, you can use streaming services directly through the Infotainment system.

Streaming services are not available in all countries and vehicle models.

Prerequisites for using streaming services:

- ✓ The requirements for using online functions in media mode have been met.
- ✓ You have your own user account for the relevant streaming service.
- ✓ The vehicle is connected to the Internet.

 Some streaming services can only be jointly activated or deactivated, even if they are listed individually in the menu.

Setting up streaming services

1. Select Media Streaming as the media source.

A list of available streaming services is displayed.

2. Select the desired streaming service.

Either an input field for inputting the registration data is shown or a guide to registering with the provider is displayed.

3. Enter the login data for the desired user profile and confirm.

The streaming services will be added as a new function key in the list of media sources.

Navigation

Introduction

The current vehicle position is determined by a global satellite system. In order to enable optimum navigation to your destination, all measured values and possible traffic information are compared with the available map material. Acoustic navigation announcements and graphic displays lead you to your destination.

Depending on the country, it may not be possible to select some Infotainment system functions on the screen when driving above a certain speed. This is not a malfunction, but rather compliance with legal regulations.

If you sell or lend the vehicle, Volkswagen recommends resetting the Infotainment system to the factory settings ⇒ *Operating the Infotainment system*. This only deletes all personal data, such as information about navigation. Please note additional information on this in the chapter on the online services, which are available depending on the country ⇒ .



WARNING

If settings are adjusted, destinations entered and changes made to navigation information while driving, the driver may be distracted and cause accidents and injuries.

- Always drive attentively and responsibly.
- Only adjust settings, enter destinations, or change navigation information when the vehicle is stationary.

 If you missed a turn on your route, the navigation system may recalculate the route.

 The quality of the driving directions depends on the available navigation data and, depending on the country, any reported traffic incidents.

 In order to use online services, e.g. Online Traffic Information, the corresponding online service needs to be activated and, depending on the country, the privacy settings need to be adapted ⇒ . Only then can online traffic information, for example, be displayed in the navigation system. If no online traffic information is available, the following symbol will be displayed depending on the vehicle equipment: .

Navigation restrictions

If the Infotainment system cannot receive data from GPS satellites, for example in a tunnel, navigation will still be possible using the vehicle's sensors.

In areas that are not digitized or only partially digitized in the Infotainment system memory, the Infotainment system will still try to provide route guidance.

If navigation data is missing or incomplete, the vehicle position may not be determined accurately. This may result in navigation that is not as accurate as usual.

The road layout is subject to constant changes, e.g. construction sites. Using outdated navigation data can lead to errors or uncertainty when using route guidance.

Function descriptions

 Please read the introductory information and heed the Warnings and Notice ⇒  and  *Safety instructions*.

Voice guidance

Navigation messages are acoustic driving directions for the current route.

The type and frequency of navigation messages depends on the settings and the driving situation, such as the start of the route guidance and whether you are driving on a highway or roundabout.

If the destination cannot be reached exactly, for example because it is not in a digitized area, there will be a navigation announcement that the Destination area has been reached. Messages about the direction and distance to your destination will also be displayed on the screen.

During dynamic route guidance, reported traffic incidents on the route are announced. There will be an additional navigation announcement if the route is recalculated due to a traffic incident or a change in driving style.

You can adjust or mute the volume during a traffic announcement. All other navigation announcements will be given at that volume or will be muted.

 Navigation messages will not be given if the Infotainment system is muted.

Adapting the Navigation Map

To ensure an optimum view, you can also adapt the navigation map and map view using enhanced finger movements.

Moving the navigation map

Recommendation: Use index finger.

1. Move the navigation map with your finger.

Zooming in or out on the map view

Recommendation: Use index finger.

1. Tap and hold the map twice in a row.
2. To zoom out of the map view, move your finger upwards.

Or: to zoom in on the map view, move your finger downwards.

Zooming in or out on the map view

Recommendation: Use thumb and index finger.

1. Tap and hold the map with two fingers at the same time.
2. To zoom out of the map view, slide your fingers towards each other.

Or: to zoom in on the map view, slide your fingers away from each other.

Tilting the map view

Recommendation: Use index and middle finger.

1. Tap and hold the map with two fingers at the same time, held horizontally next to each other.
2. To tilt the map view to the front, move your fingers upwards.

Or: to tilt the map view to the back, move your fingers downwards.

Rotating the map view

Recommendation: Use thumb and index finger.

1. Tap and hold the map with two fingers at the same time.
2. Turn your fingers clockwise or anti-clockwise to turn the map view.

Route plan

Multiple destinations can be defined in succession in the route plan. The starting point is always the vehicle position as determined by the Infotainment system. The route plan contains information about relevant events, such as waypoints and destination suggestions, if the relevant data is available to the navigation system.

Tapping an event will open a dialog box with additional options. The options available depend on the event and the current settings.

Opening and closing the route plan

1. Tap the route plan to open.
2. To close the route plan, tap >.
3. To stop the route guidance to the destination or waypoint, tap  next to the destination in the route plan.

Editing Route Guidance in the Route Plan

To edit route guidance, move the stopovers or the destination in the route plan.

1. Tap and hold the desired destination until it is visibly highlighted.
2. Move the destination to the desired position and release it.

The route will be recalculated.

Additional dialog box in the route plan

Tapping the route plan entries may cause a dialog box to open with additional options for these entries. The options available depend on the entry that is tapped.

Functions in the split screen:

Display on map Displays the selection on the map.

Add waypoint Adds a waypoint to the route guidance.

Direct route Starts direct route guidance.

Delete Delete waypoint from route guidance.

Avoid Avoid traffic disruptions. The route will be recalculated.

Stop route guidance Ends the current route guidance.

Closing an additional dialog box in the route plan

1. Tap a free area outside of the additional window.

Setting preferred POI categories

The system offers different points of interest, e.g. gas stations, using the quick select symbol when entering destinations, in the route plan and on the map. You can prioritize how these symbols are displayed under  ► Basic functions ► Preferred POI categories. The system also automatically learns your preferred categories.

Saved data

In order to enable you to enter destinations quickly and to optimize route guidance, the Infotainment system saves certain data, such as frequently driven routes and positioning data.

Delete saved data

1. Tap  ► Basic functions ► Delete usage pattern.
2. Tap confirm to delete the data.

Learning usage patterns

While driving, the Navigation system saves routes traveled and destinations reached in order to create automatic destination suggestions. Destinations are learned with reference to the time of day and the day of the week.

The navigation system can suggest pre-learned routes. Selecting one of the suggested routes will cause route guidance to

begin.

The route guidance follows the selected route until you deviate from it. The route will then be recalculated and will lead back to the selected route via the most direct path.

Relevant traffic disruptions are taken into consideration in route guidance. If an alternative route and the navigation data are available, relevant disruptions will be avoided.

If you are driving a pre-learned route without active route guidance, the destination is added to the route plan. Route guidance does not need to be actively started for a journey to a pre-learned destination. You are warned about traffic disruptions if necessary.

A predicted arrival time is displayed.

You can activate or deactivate this function at any time as well as delete the saved data for this function.

Activating or deactivating “Learn usage pattern”

1. To open this function's settings, tap  ► Basic functions.
2. Tap Learn usage pattern.

Displaying Suggested Routes

1. Tap .

Deleting saved “Learn usage pattern” data

1. To open this function's settings, tap  ► Basic functions.
2. Tap Delete usage pattern.

Functions and Symbols

 Please read the introductory information and heed the Warnings and Notice ⇒  and  *Safety instructions*.

Functions

The functions of the navigation system depend on the vehicle equipment and are not available in all countries.







- Entering a destination and route calculation.
- Simultaneous display of two navigation maps (screen and instrument cluster).
- Personal destinations.
- 3D City Maps.
- Online Map Update.
- Online Traffic Information.

Symbols

The symbols depend on the vehicle equipment and are not available not in all countries and may look different depending on the Infotainment system.

General symbols

1. To open the main menu, open the app overview and tap  ⇒ *Overview of Infotainment system*.

 Destination search.  Display additional route guidance options.  Display navigation map.  Open saved addresses (contact list for the connected cell phone).  or  Opening the settings.

Symbols on the map

The function keys and displays shown depend on the settings and the current driving situation.

Depending on the country, symbols for traffic information, e.g. traffic disruptions, and POI s, e.g. gas stations, are displayed on the map if the data is available to the navigation system ⇒ [Traffic information](#).

Current position. Align the map. Map scale. Fully automatic map mode (orientation in direction of travel, position, zoom and tilt). Display dialog box with route options. Destinations along the route. Display destination memory. Display dialog box with additional options.

Symbols in the route plan

Display current position. Destination for the current route guidance. Ends the current route guidance. Close route plan.

Symbols in the dialog box

1. To open the dialog box with further options, tap .

Display route overview and alternative routes to the current route guidance for the active route guidance. Repeats the last navigation announcement. Mute or adjust volume of navigation instructions.

Additional symbols

Personal destination suggestions (home address, work address, favorite POIs nearby). In the destination search: open detailed destination input for an address. In the contact list: open address. Display route information. Destination search: detailed destination input for an address.

Traffic disruptions

Depending on the country, traffic disruptions are displayed on the map if the data is available to the navigation system ⇒ [Traffic information](#).

1. Tap a traffic disruption to open a dialog box with details ⇒ [Function descriptions](#).

Traffic jam. Accident. Ice. Road closed. Slip hazard. Danger. Construction zone. Strong wind.

Inputting destinations and starting route guidance

Please read the introductory information and heed the Warnings and Notice ⇒ and [Safety instructions](#). Depending on the vehicle equipment, different functions are available for inputting destinations. Some functions are only available in some countries.

The various functions for inputting destinations are located in the navigation system main menu ⇒ [Introduction](#).

You can further restrict your search with specific suggestions in the results list, e.g. “nearby”.

For further information about symbols on the Infotainment system screen, see ⇒ [Functions and Symbols](#) in this Owner's Manual.

Enter address

Start route guidance by entering an address. During input, the navigation system suggests already known destinations. You can also enter a new, unknown address for route guidance.

When inputting the address, input the name of the destination, not the postcode of the destination.

Selecting the destination and starting the navigation system

1. Tap .

Or: tap .

2. Enter the destination address and select your desired destination.

3. Tap Start.

Or: tap .

Quick start

1. Tap .
2. Enter the address of the destination, tap the desired destination and hold for a few seconds.

 Enter the destination as accurately as possible. If there is an error in the destination entered, route guidance cannot take place or may lead to the wrong destination.

Destination suggestions

Navigation uses saved data such as your last destinations, learned destinations, favorites, home address and work address to provide you with route guidance.

Selecting the destination and starting the navigation system

1. Tap  ► Destination suggestions.
2. Tap on the desired destination.

The route guidance starts automatically.

Last destinations

The navigation system saves up to 25 of the most recent destinations to make them available for route guidance. A new destination automatically overwrites the oldest destination.

Selecting the destination and starting the navigation system

1. Tap  ► Last destinations.
2. Tap on the desired destination.
3. Tap Start.

Or: tap .

Quick start

1. Tap  ► Last destinations.
2. Tap and hold the preferred destination for a few seconds.

Favorite destinations

You can save up to 50 journey destinations as favorites.

Saving a journey destination as a favorite

1. While entering a destination, tap on  in the additional window.

Selecting the destination and starting the navigation system

1. Tap  ► Favorites.
2. Tap on the desired destination.
3. Tap Start.

Or: tap .

Quick start

1. Tap  ► Favorites.
2. Tap and hold the preferred destination for a few seconds.

Selecting on the map

The navigation map contains active areas at many points which are suitable for the input of a destination. To enter a destination, tap on your preferred position or preferred location on the map. If map data is available at this point, you can launch route guidance.

Entering a destination via the navigation map is dependent on data status and not possible for all positions.



Use the Offroad navigation system to enter a destination to a selected destination point with unknown data.

Offroad navigation

The Offroad navigation system calculates routes to selected destinations with unknown data. If the destination is not located on a known road or at a known position, the navigation system will calculate the route up to the next point on the known road and then complete the route to the destination using a straight line.

In order to start an Offroad navigation, tap on a free area without positioning data.

Starting the navigation

1. Tap .
2. Press and slide the map view until you can select your desired position. You can operate the navigation map using extended finger touches ⇒  [Introduction](#).
3. Tap the preferred destination or any destination point on the map without positioning data.
4. Tap Start.

Or: tap .

Using a contact's address data

Start route guidance via the saved address data for a contact. You cannot use contacts for whom you have not saved any address data for route guidance.

Starting the navigation

1. Tap .
2. Tap on the preferred contact and address data.
3. Tap Start.

Or: tap .

 If the address data for a contact is out of date, the stored address will be used when route guidance is activated and may take you to the wrong destination.

- When starting route guidance, make sure that the stored address for a contact is up to date. The phonebook must be updated completely in the Infotainment system ⇒ [Function descriptions](#).
- Wait until the phonebook update is complete in the Infotainment system ⇒ [Function descriptions](#).

Navigation data

 Please read the introductory information and heed the Warnings and Notice ⇒  and  [Safety instructions](#).

The Infotainment system is equipped with an internal navigation data storage medium. Depending on the country, the required navigation data may already be installed.

The Infotainment system always requires up-to-date navigation data to ensure that route guidance can be implemented correctly and that the functions provided are fully available.

If you use outdated navigation data, there may be adverse effects on the navigation system. It may not be possible to determine up-to-date routes, or route guidance may guide you to an incorrect destination.

- Always ensure that your navigation data is kept up-to-date.

Navigation Data Online – Additional Information

Regions in the navigation data that you do not use can be removed from the system under certain circumstances, e.g. navigation data memory low on space. If you subsequently need these regions again at a later time, the navigation system will download them again on request. No contract for mobile online services is required for this purpose. This service depends on the vehicle equipment and is only available in some countries.

1. Switch the ignition on.
2. Establish an Internet connection if you have not already done so.

The navigation data is automatically updated in the background.

Updating navigation data manually

Up-to-date navigation data for larger regions, such as Western Europe, can be downloaded online at www.volkswagen.com and stored on a suitable USB data carrier, available to buy in stores. If the Infotainment system is switched off during the process, installation will be interrupted and it will continue automatically once the system is turned on again.

1. Download and save the navigation data onto a USB data storage device.
2. Switch the vehicle ignition on.
3. Link the USB data carrier to the Infotainment system when the vehicle is stationary.

The navigation data for frequently driven regions is automatically updated in the background.

 While and after updating the navigation data, no message appears in the Infotainment system.

 If you update the navigation data manually, the USB data carrier must remain permanently connected. You will not receive a notification when the update is complete.

 Do not disconnect the USB data carrier from the Infotainment system for a few days until the navigation data for visited regions has been fully downloaded and installed. The installation will start automatically in the background during the journey. Doing so will cancel the update process. If you disconnect the data carrier and visit a new region, the navigation data is not updated due to the lack of a USB data carrier.

Displaying the map data version

1. Open the app overview and tap  ► System information.

Traffic information

 Please read the introductory information and heed the Warnings and Notice  and  *Safety instructions*.

Reception of traffic information depends on the vehicle equipment and is not available in every country. In order to be able to use the Online Traffic Information function, you must select the “online mode” and a mode with location data in the privacy settings (depending on the country).

The Infotainment system automatically receives detailed traffic information when there is an active Internet connection. This information is displayed on the map via symbols and color coding on the road network  *Functions and Symbols*, .

Traffic disruptions

Traffic disruptions such as traffic jams are displayed on the navigation map as symbols  *Functions and Symbols*.

The route plan displays current traffic disruptions if the relevant data is available to the Navigation system.

If route guidance is active, traffic disruptions on the current route will be displayed on the route plan. You can avoid these traffic disruptions by modifying the route plan.

Avoiding traffic disruptions

1. Tap the traffic disruption.
2. Tap Avoid.

The route will be recalculated.

 Only one traffic disruption can be avoided in this manner for each route guidance.

 Local warnings, e.g for severe weather, can be played via the Infotainment system as a pop-up notification.

Traffic flow display

The traffic flow for current traffic disruptions is displayed on the navigation map via color coding on the road network.

Orange Stop-and-go traffic.

Red Traffic jam.

Mobile phone interface

Introduction

Using the phone interface, you can connect your cell phone to the Infotainment system and control the phone functions via the Infotainment system. The sound is played back via the vehicle speakers. Depending on the vehicle equipment, you can connect up to three cell phones to the Infotainment system at the same time ⇒ [Coupling, connecting and managing](#).

The functions depend on the vehicle equipment, are not available in all countries and depend on the cell phone used and its operating system.

High speeds, poor weather and road conditions, a lot of background noise, even outside the vehicle, and the network quality can impair phone calls in the vehicle.

The phone interface may contain an antenna amplifier that improves the reception quality of the cell phone.

 You generally only need to pair a device like a cell phone once per technology, Bluetooth or Wi-Fi®. The connection of the device with the Infotainment system via Bluetooth or Wi-Fi can be restored at any time without re-pairing the device.

 For a phone call via the hands-free system or at a high volume, a conversation may also be heard by third parties outside the vehicle.

 During a phone call, the volume of the call can be adjusted with the volume control ⇒ [Overview of Infotainment system](#).

Locations with special regulations

Switch off the cell phone and phone interface at locations where there is a risk of explosions. These locations are not always clearly identified. These include, for example:

- Areas near pipes and tanks containing chemicals
- Lower decks in ships and ferries
- Areas near vehicles powered by liquefied petroleum gas, such as propane and butane.
- Areas with chemicals or particles in the air, such as flour, dust, or metal powder
- All other locations where the engine or the cell phone must be switched off.

WARNING

In potentially explosive environments, e.g. in the vicinity of gas stations and at other similar locations with specific regulations, ignition sparks caused by electrostatic discharge or cell phones, for example, can cause an explosion or a fire

and lead to serious or fatal injuries.

- Switch off the cell phone and phone interface at locations where there is a risk of explosions, e.g. in the vicinity of gas stations, and locations with specific regulations.
- Do not use the cell phone and cell phone interface at locations where there is a risk of explosions, e.g. in the vicinity of gas stations, and locations with specific regulations.

Types of phone interface

Depending on the country and vehicle equipment, your vehicle may have the following mobile phone interfaces:

- Phone interface basic configuration.

The phone interface uses the Hands-Free Profile (HFP) Bluetooth profile for transmission. This profile enables the use of phone functions via the Infotainment system and playback via the vehicle speakers.

- Convenience phone interface.

Just like the basic configuration of the phone interface, the Convenience phone interface uses the HFP Bluetooth profile.

The Convenience phone interface can be equipped with the wireless charging function ⇒ [Charging Options for Mobile Devices](#). In order to use the wireless charging function, you need to place a suitable cell phone correctly in the storage compartment for the wireless charging function. Depending on the vehicle equipment and cell phone compatibility, the cell phone connects to the vehicle aerial when you place the phone in the storage compartment .



Connecting to the vehicle antenna

Depending on the model and the vehicle equipment, and in some countries, using the storage compartment for the wireless charging function ⇒ [Charging Options for Mobile Devices](#) connects the cell phone to the vehicle antenna. This improves the reception and the call quality, and it can reduce interfering signals in the cell phone reception, if necessary.

If the reception or the call quality is not improved or there are still audible interfering signals in the mobile phone reception, the cell phone must be positioned the other way around, with the screen facing up, in the storage compartment for a better connection.

Depending on the vehicle model and equipment and in some countries, the wireless charging function can charge multiple cell phones simultaneously. If several cell phones are being charged at the same time, only one of the cell phones will connect to the vehicle antenna.

Coupling, connecting and managing

 Please read the introductory information and heed the Warnings and Notice ⇒  and  [Safety instructions](#). To use the phone interface functions, pair and connect a cell phone with the Infotainment system.

Depending on the vehicle equipment, you can connect up to two cell phones to the Infotainment system at the same time. However, only one device is active at a time and can be used to make calls. The second connected device can receive calls via the Infotainment system and be used to play media.

The available functions depend on the cell phone used and its operating system.

Pairing a cell phone

Before connecting for the first time, you need to pair the cell phone with the Infotainment system. A user profile is then automatically saved in the Infotainment system ⇒ [Function descriptions](#). The coupling process may take a few minutes.

Requirements:

- ✓ Bluetooth is activated on the cell phone.
- ✓ Bluetooth is activated on the Infotainment system.

1. Open the list of available Bluetooth devices on your cell phone and select the device name for the Infotainment system.

2. Pay attention to messages on the cell phone and in the Infotainment system and confirm these if necessary.

If the pairing is successful, the data on the cell phone will be saved in the user profile.

3. *Optional:* Confirm the message for transferring the data on the cell phone.

WARNING

If you as the driver carry out the pairing when driving, this may cause accidents or injuries.

- Only carry out the pairing as the driver when the vehicle is stationary.

 When pairing some cell phones, a PIN may be displayed on the cell phone screen. Type this PIN into the Infotainment system to finish pairing.

Connecting a cell phone

Precondition:

- ✓ A cell phone is paired with the Infotainment system.

1. Activate Bluetooth in the cell phone.

Function descriptions

 Please read the introductory information and heed the Warnings and Notice ⇒  and  *Safety instructions*.

User profiles

An individual user profile is automatically created for each paired cell phone. Data from this cell phone, e.g. contact data, is stored in the user profile. A maximum of ten user profiles may be saved in the Infotainment system simultaneously.

Deleting a user profile

1. Tap  .

The user profiles are located in the Select cell phone area or in Mobile devices.

2. Tap the desired user profile and tap  to delete.

Active and passive connection

In order to use the phone interface functions, at least one cell phone must be connected to the Infotainment system. If several cell phones are connected to the Infotainment system, you can switch between an active and an inactive connection. In order to operate the phone interface with your preferred cell phone, establish an active connection to the Infotainment system.

Difference between the types of connection

Active The cell phone is paired and connected. You can carry out phone interface functions using data from this cell phone.

Passive The cell phone is paired and connected. You can only take incoming calls via the phone interface. Other functions are not available.

Paired cell phones are saved in the Infotainment system even if they are not currently connected.

Change connection type (inactive to active)

Precondition:

- ✓ Several cell phones are connected to the Infotainment system simultaneously.

1. Tap .

The actively connected cell phone is highlighted.



2. Tap the name for the preferred cell phone.

The connection with the other cell phones will be inactivated automatically.

Connection management

Precondition:

- ✓ The cell phone is paired and connected.

1. Tap   Mobile devices.
2. Tap to connect the desired technology.

Phonebook

This first time a cell phone is paired with the Infotainment system, the phonebook is saved in the Infotainment system. If necessary, confirm the transfer on the cell phone.

Depending on the vehicle equipment, you can save up to 5000 contacts in your phonebook.

The phonebook is updated after each new connection. During the update, the present phone directory can still be used.

If teleconferences are supported, the phonebook can be opened during a phone call and another participant can be added to the phone call.

If an image is stored for the contact, it can be displayed in the list next to the entry.



The symbols may look different depending on the Infotainment system.

Using a phone

Select a telephone number to make a call. Various functions are available for selecting a telephone number.

Using contact data

If a contact has multiple telephone numbers, you must select the number you wish to call accordingly.

1. Tap .
2. To search for a contact, tap  and enter the name of the contact in the input field.
Or: tap Favorites.
Or: Tap All.
3. Tap on a contact in the list to make the call.



 When searching for a contact, enter the last name and first name separated by a space.

Using a call list

The mobile phone interface stores the incoming and outgoing calls on a call list. Recently used telephone numbers are saved under favorites. Make a call via the call list.

1. Tap  and filter entries in the call list, e.g. by missed calls.
2. Tap on a number or, where applicable, a contact in the list to make the call.

Manually entering the telephone number

1. Tap  and enter a telephone number.
2. Tap  to make the call.

 While you are entering a telephone number, the contact related to the number is displayed on the Infotainment system screen.

Favorites and speed dial keys

A speed dial key can be assigned with a favorite from the phonebook. If the entry contains an image, this is displayed on the speed dial key.

Speed dial keys must be programmed manually and are assigned to a user profile ⇒ *Coupling, connecting and managing*, ⇒ *Bluetooth® interface*.

Programming a speed dial key

1. Tap .
2. Tap a contact in the phonebook. If a contact has multiple telephone numbers, tap a number on the list.

Editing the speed dial key



1. Tap and hold the speed dial key until the phonebook opens.
2. Tap the new contact in the phone directory. If a contact has multiple telephone numbers, tap a number on the list.

Calling a favorite

1. Tap a programmed speed dial key.

 Favorites are not automatically updated. If the phone number for a contact changes, the speed dial key must be reassigned.

Deleting a favorite from the speed dial key

1. Tap .
2. To delete a favorite, tap the preferred speed dial key .

Sending text messages

Depending on the cell phone and the Infotainment system in use, you can send and receive SMS text messages and, depending on your country, e-mails via the phone interface.

Sending and receiving e-mails is also dependent on the app used on the cell phone.

Sending an SMS

1. Tap  ► SMS ► New message and enter the message on the screen.
2. Enter the desired contact in the search bar and tap.
3. Tap OK to send the message.

Sending an e-mail

1. Tap  ► E-MAIL ► New message and enter the message on the screen.
2. Enter the desired contact in the search bar and tap.
3. Tap OK to send the message.

Switching between SMS and e-mail

To send an e-mail or SMS, activate the relevant option. The active option is displayed on the screen, e.g. SMS.

1. Tap .
2. Tap the desired option.

Functions and Symbols

 Please read the introductory information and heed the Warnings and Notice ⇒  and  *Safety instructions*.

Functions

The functions depend on the vehicle equipment and are not available in all countries. The available functions depend on the cell phone used and its operating system.







- Hands-free system.
- SMS functions via Bluetooth:
 - Read SMS.
 - Write SMS, inc. templates.
 - Have an SMS read out.
 - Message thread.
- E-mail functions via Bluetooth:
 - Read e-mail.
 - Write e-mail.

Symbols











The symbols depend on the vehicle equipment and are not available not in all countries and may look different depending on the Infotainment system.

General symbols

1. To open the main menu, open the app overview and tap  ⇒ [Overview of Infotainment system](#).

 Open contact list.  Open incoming and outgoing calls lists.  Dial telephone number.  Open messages (SMS and, depending on your country, e-mail).  Select the active device from two or more connected cell phones.  Opening the settings.

Symbols for telephone calls

 Handle and display a call.  End or decline a call.  Mute the hands-free system.  Put a call on hold.  Decline a call with a SMS template.  Add participants to a phone conference or begin a phone conference.  Make an emergency call (SOS).  Receive roadside assistance.  Voice mail.  Receive information about Volkswagen and various value added traffic and travel services.





Symbols in the contact list

1. To open the contact list, tap .

 Input to search for contacts.  Address.  Editing favorites.  Add favorites.  Remove favorites.





Call list symbols

1. To open the call lists, tap on .

 Received incoming call.  Outgoing call.  Missed call.  Frequent calls or favorites from your cell phone, if supported by your cell phone.  Telephone number (company).  Telephone number (private).  Cell phone number.  Fax device.  Fax device (company).  Fax device (private).

Text message symbols

1. To open the text messages, tap on .

 Top left: Select active input.  Received text message.  Sent text message.  Template for text messages.



Voice control

Introduction

With voice control, you can have certain functions carried out by voice command.

Does my vehicle have voice control?

If the  button is present on the multi-function steering wheel and the voice control is started after pressing it, or your vehicle understands the activation command ⇒ [Activation command and voice commands](#), voice control is installed in the vehicle.

 Voice control is active and recognizes spoken words.
 Test voice control before a journey to get to know the function.

Features of voice control

Depending on your country and the language set as the system language in the Infotainment system, voice control will be available both online and offline.

Voice commands ⇒ [Activation command and voice commands](#) can be freely formulated and informal, depending on the system language. Voice commands depend on the system language and the vehicle equipment. For example, the statement “I’m cold” leads to an increase in the vehicle’s temperature.

Depending on the system language, voice commands evaluated online allow an optimized search, for a POI, for example. Messages can also be dictated. For online mode, you will require a valid contract for using mobile online services for the vehicle ⇒ .

In some languages, voice commands must be formulated according to a certain pattern in order to be successfully recognized, e.g. “navigate to [*city, street name, house number*]”.

Further examples and suggestions for voice commands depend on the system language. These can be found in the Infotainment system ⇒ [Activation command and voice commands](#).

 The number of languages available in your country depends on the country.

 If the voice control is available online in your language, it is used when the voice control is activated.

Speech recognition for individual seating positions

Depending on the vehicle equipment and model, in some countries additional microphones enable voice control to recognize whether the driver or passenger is speaking. For supported languages, you can open functions for individual seat positions, for example switching on the seat heating.

Activation command and voice commands

Activation command

The spoken words are continuously analyzed in the vehicle and overwritten after approximately 15 seconds. As soon as the Infotainment system recognizes the activation word, voice control will begin. If voice control is available online and activated, (voice) data will also be derived from the vehicle from this point onwards. Otherwise, there is no transmission of data or words spoken in the vehicle.

Detection of the activation word can be deactivated in the settings .

Voice control recognizes “Hello Volkswagen” as the activation command.

 Bonjour Volkswagen.  Hola Volkswagen.  Hello Volkswagen.

Activating or deactivating the activation command

If the activation word is deactivated, voice control cannot be started via the activation word.

1. Open the app overview and tap  ► Voice control ► Voice control start/end sound or Activation word.

Voice commands

Voice control only recognizes voice commands in the language selected in the infotainment system.

Observe the following tips for successful voice commands:

- ✓ Speak clearly and at normal volume. Speak a little louder at higher speeds.
- ✓ Avoid excessive emphasis and strong accents.
- ✓ Do not leave long pauses in speech.
- ✓ Avoid external and background noise.
- ✓ Do not direct the air flow from the vents towards the microphone or headliner.

Open suggestions for speech commands

1. Open the app overview and tap  ► .



Or: open the app overview and tap  ► .

 To ensure that names in the phonebook are identified correctly, you may need to switch the order of the first and last names of the desired contact, depending on how the phonebook entry is structured.





Starting and ending voice control

Starting voice control



1. Activate the activation command ⇒ *Activation command and voice commands*.
2. Say the activation command ⇒ *Activation command and voice commands*.



Or: press  or  on the multi-function steering wheel.

Or: tap .

 Depending on the cell phone and operating system, and also for some Infotainment systems, the voice control of a connected cell phone can be started by pressing and holding the  or  button, the sensor area or the  button ⇒ *App-Connect*.

Ending voice control manually

1. To open suggestions for a voice command to cancel, open the app overview and tap  ►  ► General.

Or: open the app overview and tap  ►  ► General.

Or: press  on the multi-function steering wheel twice in quick succession or press  once.

 Voice control will end automatically in the following scenarios:

- Functions in the Infotainment system are being used.
- The parking system is activated.
- During an incoming call.
- During tasks involving speech and navigation warnings.

Troubleshooting

Voice control is not responding

- Voice control is not available in your language.
- Set the correct system language in the Infotainment system.
- Start voice control by using the activation word or the button on the multi-function steering wheel.
- Voice commands are not recognized due to a system error. Contact suitably qualified professionals for assistance. Volkswagen recommends contacting an authorized Volkswagen dealer or authorized Volkswagen Service Facility.

Voice control is giving unsuitable responses

- Voice control has misinterpreted the question.
- Clearly give your voice command again.

Voice control is not performing the function

- This function cannot be performed by voice control.
- The function is not available in all languages. You can find suggestions for voice commands in the set language in the Infotainment system.
- Settings within the function are preventing the device from switching on or carrying out the function.
- Voice control did not understand the voice command.
- There is insufficient data.

Transporting

Stowing luggage and cargo

Stowing luggage securely in the vehicle

- Distribute luggage as evenly as possible in the vehicle. Do not cover any vent openings.
- Always stow luggage and heavy objects in the luggage compartment and place them as far forward in the compartment as possible ⇒ .
- Adhere to the Gross Axle Weight Rating and Gross Vehicle Weight Rating ⇒ *Technical data*.
- Secure objects in the luggage compartment using suitable securing cords, fixation belts or tensioning straps on the tie-downs.
- Also store small objects securely.
- If necessary, fold the rear seat backrest down and lock it securely.
- If necessary, adjust the headlight range. Vehicles with dynamic headlight range control will adjust automatically.
- Adjust the tire pressure based on the load. Follow the tire pressure label ⇒ *Checking the tire pressure*.
- If necessary, calibrate the Tire Pressure Monitoring System (TPMS) to the new load.

WARNING

Objects or animals that are not secured or are secured incorrectly can cause serious or fatal injuries in the event of sudden driving and braking maneuvers or a collision. This is especially true if the airbags deploy and strike objects, causing them to fly through the vehicle interior.

- Store all objects securely in the vehicle. Follow the legal regulations whilst doing so.
- Stow objects in the vehicle interior in such a way that they will not enter the airbag deployment zone while you are driving.
- Secure animals in the vehicle restraint systems that are appropriate for their weight and size.
- Always keep the storage compartments closed while driving.
- Do not leave hard, heavy, or sharp objects loose in the open storage compartments in the vehicle, on the surface behind the rear seat backrest, or on the instrument panel.
- Remove hard, heavy, or sharp objects from clothing and bags in the vehicle interior and store them securely.

WARNING

If objects stowed in the vehicle cause people to sit in the wrong position, serious or fatal injuries may occur in the event of sudden driving and braking maneuvers or accidents.

- Never stow objects on a seat if a person is going to use it.

WARNING

When transporting heavy objects, the vehicle's handling performance may change because of the altered center of gravity and the braking distance may increase. Heavy loads that have not been stowed or secured properly may change the vehicle handling, e.g. if the load slides around. This can result in a loss of vehicle control and lead to serious or fatal injuries.

- Never overload the vehicle. Both the load and the distribution of the load in the vehicle affect driving behavior and braking efficiency.
- Always distribute the load evenly and as low down in the vehicle as possible.
- Secure heavy objects in the luggage compartment as far in front of the rear axle as possible.
- Secure any loose objects to prevent them from sliding around.
- Always adapt your speed and driving style to the visibility, weather, road and traffic conditions.
- Take extra care and caution when accelerating.
- Avoid sudden braking or driving maneuvers.
- Brake earlier than usual if the vehicle has a heavy load.

⚠ NOTICE

Abrasive objects on the rear windows can cause damage, e.g. to the heating conductors of the rear window defroster.

- Do not load the luggage compartment to a height where objects rest against the rear window.

⚠ NOTICE

Carrying systems fixed to the rear spoiler may damage the vehicle.

- Do not attach a luggage rack or any other kind of carrying system, e.g. bicycle rack, to the vehicle's rear spoiler.

Luggage compartment cover

Opening and closing the luggage compartment cover



Fig. 130 In the luggage compartment: open the luggage compartment cover (general example).

- 1 Recessed grip in the luggage compartment cover.

Opening the luggage compartment cover

Depending on vehicle equipment, there may be a luggage compartment cover located behind the second row of seats.

1. Pull the luggage compartment cover out by the handle *fig. 130* 1 and pull it upward out of the side retainers.
2. Guide the luggage compartment cover forward by hand. The luggage compartment cover will roll up by itself.

Closing the luggage compartment cover

1. Pull the luggage compartment cover back by the handle *fig. 130* 1 and attach it to the anchorage.

⚠ WARNING

Objects or animals on the luggage compartment cover can damage the luggage compartment cover and cause serious injury or death in the event of sudden driving and braking maneuvers or an accident.

- Never transport objects on the luggage compartment cover.
- Never allow animals to ride on the luggage compartment cover.

ⓘ NOTICE

If the luggage compartment cover is not held, it can spring forward unbraked. This may cause damage in the luggage compartment and to the luggage compartment cover.

- Always guide the luggage compartment cover forward by hand.

Installing and removing the luggage compartment cover



Fig. 131 In the luggage compartment: removing the luggage compartment cover.

- ① Side panel on the luggage compartment cover.

Removing the luggage compartment cover

1. Open the luggage compartment cover if necessary.
2. Press the side panel on the luggage compartment cover *fig. 131* ① in the direction of the arrow and hold it in place.
3. Remove the luggage compartment cover upward and release the side panel *fig. 131* ①.

Installing the luggage compartment cover

1. Insert one side of the luggage compartment cover into the mount on the side trim panel.
2. Press on the side panel on the other side of the luggage compartment cover and hold it in place.
3. Guide the side panel *fig. 131* ① into the mount on the side trim panel.
4. Release the side panel on the luggage compartment cover.
5. Check that the luggage compartment cover is securely engaged.

WARNING

If a cover has been installed in front of a rear seat, it can cause serious or fatal injuries during braking maneuvers or an accident.

- Never install the luggage compartment cover in front of the third row of seats if anyone is sitting in the third row seats.

Storing the luggage compartment cover

Depending on the vehicle equipment, it may be possible to store the removed luggage compartment cover under the luggage compartment floor.

Luggage compartment floor

Opening and closing the luggage compartment floor



Fig. 132 In the luggage compartment: opening the luggage compartment floor.

- ① Recessed grip in the luggage compartment floor.



Fig. 133 In the luggage compartment: securing the luggage compartment floor in place.

Opening the luggage compartment floor

1. If necessary, detach the luggage net.
2. Grasp the handle in the luggage compartment floor *fig. 132* and lift up the floor panel in the direction of the arrow.
3. To secure in place, guide the luggage compartment floor in the mounts *fig. 133* (arrow) on the sides of the luggage compartment floor.

Closing the luggage compartment floor

1. Lift the secured luggage compartment floor and guide it downward.

2. Place the luggage compartment floor on the side supports.

ⓘ NOTICE

Improper use may damage the luggage compartment floor or the luggage compartment trim.

- When closing the luggage compartment floor, always carefully guide it downward, and do not drop it.
- Always distribute loads as evenly as possible across the entire luggage compartment floor to avoid concentrating the load in a single place.

Luggage compartment features

Tie-downs



Fig. 134 In the luggage compartment: Tie-down (general example).

① Tie-down.



Fig. 135 In the luggage compartment: Foldable tie-down (general example).

Tie-downs are located in the luggage compartment to secure loose objects and luggage with the help of lines, fixation belts or securing straps *fig. 134* , *fig. 135*.

⚠ WARNING

Unsuitable or damaged tie-down straps or tensioning straps could break during braking maneuvers or an accident. This could result in objects being thrown through the vehicle interior and causing serious or fatal injuries.

- Use only suitable and undamaged tie-downs, fixing and tensioning straps.
- Secure cords, fixation belts and tensioning straps diagonally and tightly across the items placed on the luggage compartment floor, and fasten the cords, fixation belts and tensioning straps securely to the tie-downs.
- Make sure that the upper edge of the load is above the tie-downs, especially on flat objects.
- Follow the signs about storing cargo in the luggage compartment, depending on the vehicle equipment.
- Never secure a child restraint to the tie-downs.

⚠ WARNING

Elastic tensioning straps must be stretched for securing to the tie-downs and are therefore under tension. If elastic tensioning straps slip off and “spring back” toward your body, the hooks attached to them may cause serious injuries.

- Protect your eyes and face when securing and releasing the straps.
- Always hold on to the hooks of the luggage net to prevent them springing out of the tie-down when hooking and unhooking them.
- Always secure elastic tensioning straps to the tie-downs in the front part of the luggage compartment first. Then pull them to the loading edge. Secure the elastic tensioning straps to the tie-downs so that they will “spring away” from your body if they come off.

 Suitable straps and cargo securing systems are available from an authorized Volkswagen dealer or authorized Volkswagen Service Facility. Volkswagen recommends contacting an authorized Volkswagen dealer or authorized Volkswagen Service Facility.

Luggage net

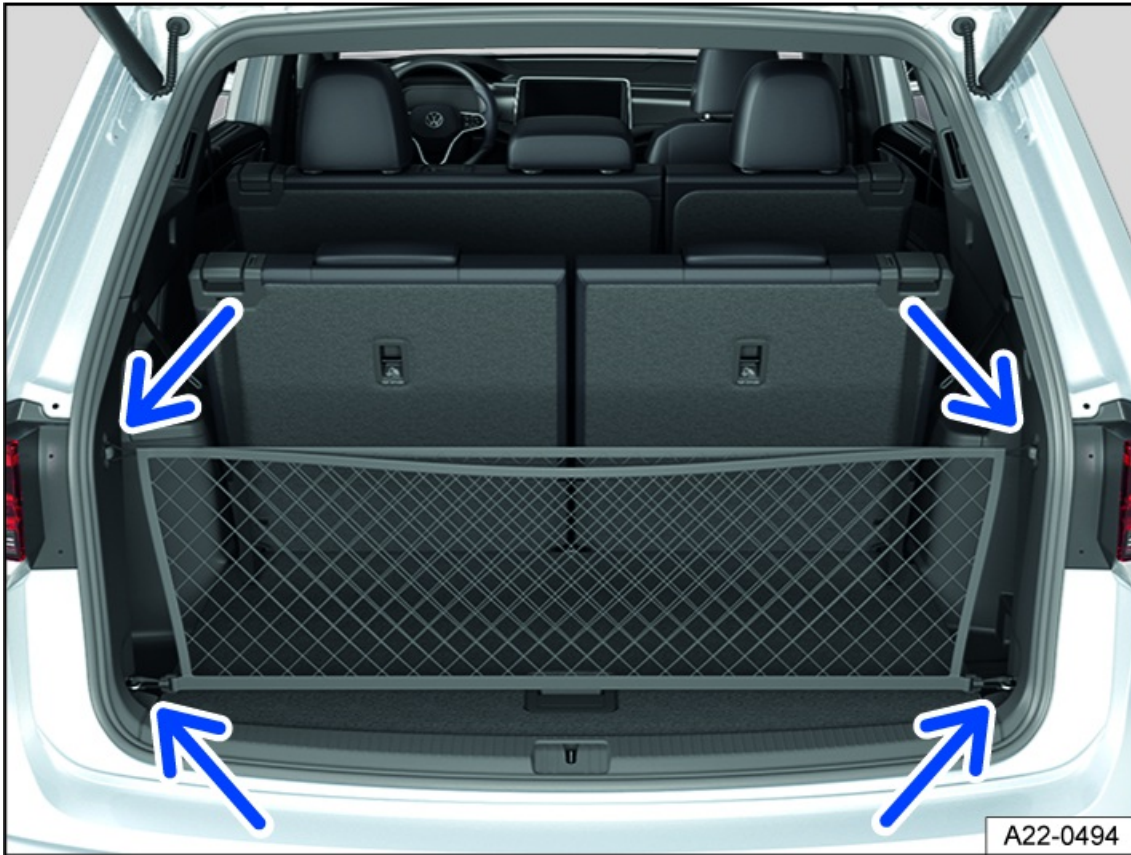



Fig. 136 In the luggage compartment: luggage net secured on the loading edge.



Fig. 137 In the luggage compartment: Luggage net hooks.

The luggage net can help to prevent light objects from sliding around in the luggage compartment. The luggage net contains a pocket with a hook-and-loop fastener for storing small objects.

Setting up the luggage net

1. Secure the hooks in the luggage net to the tie-downs on the loading edge *fig. 136* (bottom arrows) ⇒ . The zipper of the luggage net must face upward.
2. Secure the tabs on the luggage net to the side hooks *fig. 137*, ⇒ .

Removing the luggage net

The luggage net is under tension when it is installed ⇒ .

1. Release the hooks and tabs on the luggage net from the tie-downs and luggage net hooks.
2. Store the luggage net in the luggage compartment.

WARNING

An elastic luggage net needs to be stretched for securing to the tie-downs, which means that it is held under tension. If an elastic luggage net slips off and springs back toward your body, the hooks attached to them may cause serious injuries.

- Protect your eyes and face when securing and releasing the straps.
- Always hold on to the hooks of the luggage net to prevent them springing out of the tie-down when hooking and unhooking them.
- Always secure the hooks of the luggage net in the order described so that, if the luggage net does snap off, it does so away from your body.

WARNING

If used improperly, the luggage net hooks could break during a braking maneuver or in the event of an accident. This could result in objects being thrown through the vehicle interior and causing serious or fatal injuries.

- Only use the luggage net hooks to secure a luggage net.
- Never secure a child restraint to the luggage net hooks.

Shopping bag hooks



Fig. 138 In the luggage compartment: shopping bag hooks.

① Fold-out shopping bag hooks.

You may have shopping bag hooks in your luggage compartment for hanging light shopping bags.

⚠ WARNING

Luggage or other items tied to the shopping-bag hooks may tear off and be thrown into the vehicle interior during a braking maneuver or accident. This may cause you to lose control of the vehicle and result in serious or fatal injuries.

- Never use the shopping bag hooks to tie down pieces of luggage or objects.
- Only hang lightweight items, up to a maximum of 2.5 kg (approximately 5.5 lbs), from the shopping bag hooks in the vehicle.

Trailer towing

📖 Introduction

If equipped correctly, the vehicle can be used to tow a trailer.

Driving a trailer not only increases the vehicle load, but requires more concentration from the driver.

The increased weight from towing affects vehicle wear, fuel consumption, and vehicle performance and may shorten the service intervals.

If the vehicle is driving with a heavy load, functions such as the air conditioner power may be reduced or deactivated to prevent the vehicle from becoming stranded in traffic. Avoid long or large inclines. In the event of prolonged loads, the engine torque can be reduced temporarily to prevent the engine or transmission overheating. Reduce the speed and observe the information and warning and indicator lights in the instrument cluster. When the engine and the transmission are working at the optimal temperature range again, the engine torque reduction is canceled.

The load that a vehicle is able to pull decreases under the following conditions:

- Driving on slopes.
- Driving at high altitudes.
- Driving in high outside temperatures.
- Driving with a fully loaded vehicle, e.g. with passengers and luggage.
- With increasing speed.

Vehicles with a start/stop system

Before trailer towing using towing brackets which have not been retrofitted by Volkswagen, the start/stop system must be manually deactivated and remain deactivated during the entire trailer towing process ⇒ *Start-stop system*.

Trailer with function check for the lighting

No trailer with tail lights and brake lights that require a function check for the tail light or brake light in order to be approved may be operated on this vehicle. Consult the trailer manufacturer to find out what approval applies to your trailer.

Unused ball mount

Swivel the ball mount or remove it if there is no trailer, bicycle rack or similar attached to the ball mount. This is especially applicable if the vehicle's license plate or lighting is obscured by the unused ball mount. Note the country-specific regulations for using a ball mount ⇒ .

Special conditions

Before driving with a trailer, please note that the functions of the assistance and parking systems may be limited.

DANGER

Transporting persons in a trailer can cause life-threatening injuries and may be against the law.

- Never transport anyone in a trailer.

WARNING

Using the trailer hitch incorrectly can result in loss of control of the vehicle, accidents and serious or fatal injuries.

- Install and use the trailer in accordance with the instructions provided by the corresponding manufacturer.
- Only use the ball mount if it is undamaged and secured correctly.
- Do not modify or repair the ball mount. Removal of the coating on the ball mount is permitted if the installation instructions of the trailer manufacturer require this.

WARNING

If the ball mount is swiveled out, there is an increased risk of accidents and serious injuries for pedestrians and cyclists near parked vehicles and if rear collisions occur.

- Swivel the ball mount in or remove it when it is not in use.

WARNING

The vehicle has not been designed for “weight-bearing” or “load-compensating” trailer hitches. The trailer hitch could malfunction and the trailer could disconnect from the vehicle. This can cause accidents and serious injuries.

- Never install “weight distributing” or “load equalizing” ball mounts.

WARNING

Driving with a trailer and transporting heavy or large objects can change the vehicle handling performance, increase the braking distance and cause accidents and serious or fatal injuries.

- Always secure cargo correctly with suitable and undamaged cords, fixation belts or tensioning straps.
- Note that trailers with a high center of gravity may tip sooner than trailers with a low center of gravity.
- Always adapt your speed and driving style to the visibility, weather, road and traffic conditions.
- Always drive carefully and try to anticipate what may be ahead.
- Take extra care and caution when accelerating.
- Avoid abrupt and sudden driving and braking maneuvers.
- Do not drive faster than 80 km/h (50 mph), or 100 km/h (60 mph) if absolutely necessary, when towing a trailer. This also applies in countries where higher speeds are permitted.
- Reduce the vehicle speed, especially when driving uphill or downhill.
- Always observe the country-specific maximum permissible speed for vehicles with trailers.
- Overtake especially carefully and reduce vehicle speed as soon as you detect the slightest swaying movement in the trailer.
- Never try to “straighten out” a swaying trailer by accelerating.
- Look out for potential messages and warning and indicator lights turning on in the Volkswagen Digital Cockpit because of the increased load for the towing vehicle.

WARNING

When towing with towing brackets which have not been retrofitted by Volkswagen the start/stop system must always be manually deactivated. Otherwise this can lead to a failure in the brake system and can cause accidents and severe injury.



- Always switch off the start-stop system manually if you have fitted a trailer hitch which has not been retrofitted by an authorized dealer and are driving with a trailer.

 If you have integrated a trailer into the anti-theft alarm system, breaking the connection to the trailer may trigger the anti-theft alarm system ⇒ *Anti-theft alarm system*.

 Do not tow a trailer during the first 1000 km (600 miles) driven with a new engine ⇒ *Breaking in the engine*.

 Some retrofitted trailer hitches cover the mount for the towing eye. If this is the case, it will not be possible to use the towing eye to tow other vehicles. Because of this, you should always keep the ball mount from a retrofitted trailer hitch inside the vehicle when it is removed.

Hitching a trailer

 Please read the introductory information and heed the Warnings and Notice ⇒  and  *Introduction*.

Trailer socket

The towing vehicle and the trailer are connected electrically using a 7-pin trailer socket. If the trailer does not have a 7-pin connector, a suitable adapter must be used.

1. Lift the socket cap and insert the plug.
2. Rotate the plug clockwise by a quarter of a rotation until it fully engages into the socket.
3. To lock the connector in place, release the cap.
4. Check that the entire lighting system is working properly before starting the journey.

If you are not sure how to connect the trailer with the towing vehicle's electrical system correctly, consult an authorized Volkswagen dealer or authorized Volkswagen Service Facility. Volkswagen recommends contacting an authorized Volkswagen dealer or authorized Volkswagen Service Facility.

Securing cables

In some countries, unbraked and braked trailers must be secured by means of securing or breakaway cables.

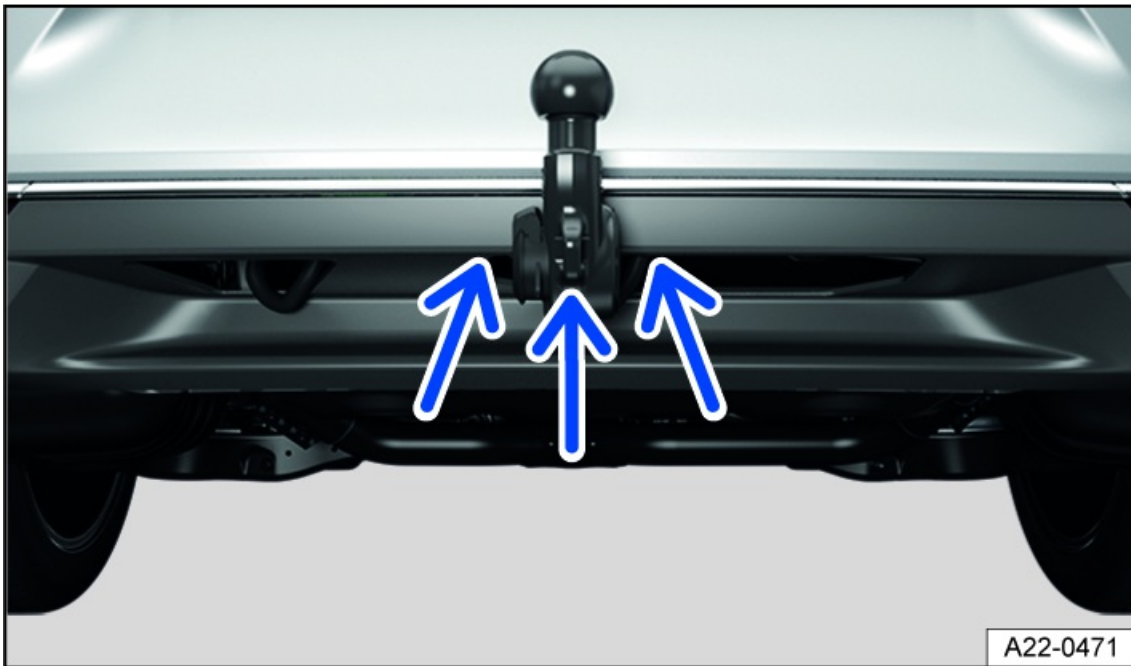

Fig. 139 On the trailer hitch: eye for fastening the securing or breakaway cable (general example).

Depending on the model, the eye for fastening the securing or breakaway cable can be located on the neck of the ball head or next to the ball head directly on the base plate of the ball mount *fig. 139* (arrows).

Follow the country-specific regulations for using a securing cable.

Fastening a securing or breakaway cable to the eye on the ball mount provided for this purpose *fig. 139*:

1. Guide the cable through the eyelet and hook it in the karabiner ⇒ ⚠.

Safety chains

Always make sure that the safety chains are correctly secured on the vehicle. The safety chains require sufficient play and sag, but should not touch the ground.

Integrating into the anti-theft alarm system

The trailer is integrated into the anti-theft alarm system if the following requirements are met:

- ✓ If the vehicle is equipped with a factory-installed anti-theft alarm system and trailer hitch.
- ✓ If the trailer is connected to the electrical system in the towing vehicle.
- ✓ If the vehicle and trailer electrical systems are functioning correctly and are not damaged.

- ✓ If the vehicle was locked using the vehicle key and the anti-theft alarm system is active.

When the vehicle is locked, the alarm will be triggered if the electrical connection to the trailer is disconnected.

Trailers with LED taillights cannot be integrated into the anti-theft alarm system due to the technology involved.

When the vehicle is locked, the alarm will not be triggered if the electrical connection to the trailer with LED taillights is disconnected.

WARNING

Improperly or incorrectly connected electrical wires can electrify the trailer and lead to malfunctions in the entire vehicle electronics system as well as accidents and serious or fatal injuries.

- Have all work on the electrical system performed only by an authorized Volkswagen dealer or authorized Volkswagen Service Facility. Volkswagen recommends contacting an authorized Volkswagen dealer or authorized Volkswagen Service Facility.
- Never connect the electrical system on a trailer to the electrical connectors for the taillights or other power sources on the towing vehicle.

WARNING

Contact between the pins on the trailer socket can cause short circuits, overloading of the electrical system, or malfunction of the lighting system, which can result in accidents and serious or fatal injuries.

- Never connect the pins in the trailer socket to one another.
- Have bent pins repaired only by an authorized Volkswagen dealer or authorized Volkswagen Service Facility. Volkswagen recommends contacting an authorized Volkswagen dealer or authorized Volkswagen Service Facility.

WARNING

An improperly secured trailer can cause accidents and serious injuries or death.

- Never drape the securing or breakaway cable of the trailer loosely over the ball mount.

NOTICE



If a trailer hitched to the vehicle is resting on a supporting wheel or on the trailer support, the vehicle may lift and lower due to changes in the load or tire damage. This would put great stress on the trailer hitch and the trailer. This can cause damage to the vehicle and trailer.

- Note that a trailer that is resting on a supporting wheel or on the trailer support should not remain hitched to the vehicle.

 If the engine is stopped and accessories on the trailer are on while there is an electrical connection through the trailer socket, then the 12 V vehicle battery will drain.

 The electrical connection to the trailer will be automatically disconnected if the charge level of the 12 V vehicle battery becomes too low.

Loading a trailer

 Please read the introductory information and heed the Warnings and Notice ⇒  and  [Introduction](#).

General information

If the vehicle is approved for trailer mode, note applicable local rules and regulations for driving with a trailer and the use of a trailer hitch.

Always ensure that the vehicle and trailer are well balanced. Do not load the trailer unevenly by putting more weight at either the front or the back. Always store heavy objects as close as possible to or above the axle. Always secure the load on the trailer properly ⇒ .

Trailer load and tongue weight

The trailer load is the weight that the vehicle can tow.

The trailer tongue weight rating is the load that presses down vertically from above onto the ball mount of the trailer hitch.

Volkswagen recommends always using the maximum permissible trailer tongue weight rating ⇒ [Technical data](#). An insufficient trailer tongue weight rating negatively affects the handling of the vehicle and trailer. The maximum permissible trailer tongue weight rating of the trailer drawbar on the trailer hitch ball head must not be exceeded ⇒ .

The actual trailer tongue weight rating increases the weight on the rear axle and reduces the possible load in the vehicle.

In some countries, under certain conditions, a higher trailer tongue weight rating can be used. Follow the local specifications and regulations.

Towing weight

The towing weight consists of the actual weights of the loaded towing vehicle and the loaded trailer.

In some countries, trailers are divided into classes. Volkswagen recommends consulting with an authorized Volkswagen dealer or authorized Volkswagen Service Facility about suitable trailers. Volkswagen recommends contacting an authorized Volkswagen dealer or authorized Volkswagen Service Facility.

Tire pressure

The tire pressure for the tires on the trailer is based on the recommendation of the trailer manufacturer.

When towing a trailer, inflate the tires on the towing vehicle to the maximum permissible tire pressure ⇒ [Checking the tire pressure](#).

WARNING

Sliding loads can considerably impair driving stability and trailer safety and increase the risk of accidents and serious injuries or death.

- Always load trailers correctly.
- Always secure cargo with suitable and undamaged cords or tensioning straps.

WARNING

If the gross axle weight rating, trailer tongue weight rating, gross vehicle weight rating or towing weight of the vehicle and the trailer are exceeded, accidents and serious injuries or death can result.

- Never exceed the specified values ⇒ [Technical data](#).

Driving with a trailer

 Please read the introductory information and heed the Warnings and Notice ⇒  and  [Introduction](#).



Characteristics when driving with a trailer

- When driving with a trailer with an overrun brake, first brake gently then rapidly. This avoids braking jolts due to the trailer wheels locking.
- The braking distance increases due to the gross combination weight (of the trailer and vehicle).
- Use the engine as an additional brake on slopes. Otherwise the brake system may overheat and possibly fail.
 - Select a lower gear when driving with an automatic gearbox in Tiptronic mode.
- The vehicle's center of gravity, and thereby also its driving characteristics, are changed by the towing weight and the increased total weight of the vehicle and trailer.
- An empty towing vehicle and loaded trailer create a very unfavorable weight distribution. Drive very carefully and slowly with this combination.

Driving on hills with a trailer

Depending on the angle of the hill and the total weight of the trailer, a parked trailer may roll back slightly when you start driving.

When towing a trailer, start on a hill as follows:

1. Press and hold the brake pedal.
2. Engage the **D/S** selector lever position.
3. Pull and hold the  switch one time to hold the trailer in place with the electronic parking brake.
4. Release the brake pedal.
5. Start driving slowly.
6. Only release the  button once the engine has generated enough drive power to start driving.

WARNING

Towing a trailer incorrectly can result in loss of control of the vehicle and cause serious injuries or death.

- Bear in mind that the driving characteristics change when driving with a trailer and transporting heavy or large objects.
- Always adapt your speed and driving style to the visibility, weather, road and traffic conditions.
- Always drive carefully and try to anticipate what may be ahead.
- Take extra caution when overtaking.
- Reduce the vehicle speed as soon as you detect the slightest swaying movement in the trailer.
- Take extra care and caution when accelerating.
- Brake earlier than usual as the braking distance may be longer.
- Avoid abrupt and sudden driving and braking maneuvers.
- Reduce the vehicle speed, especially when driving downhill.
- Never try to “straighten out” a swaying vehicle and trailer by accelerating.
- Adhere to the applicable local maximum speed limit, which may be lower for vehicles towing a trailer than it is for vehicles that are not towing a trailer.

WARNING

A poor rear view when pulling a trailer may result in accidents and serious or fatal injuries.

- Ensure sufficient visibility behind you.
- Install additional rearview mirrors to ensure you have a clear rear view.

Trailer stabilization



 Please read the introductory information and heed the Warnings and Notice ⇒  and  *Introduction*.

If a trailer is hitched to the vehicle and it begins to sway, the trailer stabilization can detect this and countersteer.

Trailer stabilization is an additional feature of the Electronic Stability Control (ESC).

If the system detects that the trailer is swaying, the trailer stabilization will automatically provide counter-steering assistance to reduce the “vibration” of the trailer.

Trailer stabilization requirements

- The trailer hitch must be installed at the factory or a compatible trailer hitch must be retrofitted.
- Electronic Stability Control (ESC) and anti-slip regulation (ASR) are active. The  or  indicator light in the instrument cluster must not be on.
- The trailer must be connected to the electrical system in the towing vehicle via the trailer socket.
- The driving speed must be less than 60 km/h (37 mph).
- The maximum tongue weight must be used.
- The trailer must have a fixed drawbar.
- Braked trailers must have a mechanical overrun protection device.

System limitations

The trailer stabilization may not respond or may have a limited response in the following driving situations.

- The trailer stabilization switches off when ESC is deactivated.
- Trailer stabilization may not always detect if a light trailer is swaying and stabilize it.
- When driving on slippery roads with poor traction, the trailer can still jackknife despite the trailer stabilization.
- Trailers with a high center of gravity can tip before you notice any swaying back and forth.
- If there is no trailer hitched to the vehicle but there is a connector in the trailer socket, for example from a bike carrier with lights, sudden braking maneuvers may occur automatically in extreme driving situations.

WARNING

The trailer stabilization is not a replacement for the driver's attention and works only within the system limitations. This means that the trailer stabilization cannot detect all driving situations and may not react, or may react with a delay, or may react in a way that is not desired. If you are careless, there is a risk of accidents, serious injuries and death.

- Always stay attentive and do not rely solely on the system. The driver is always responsible for control of the vehicle.
- Observe the system limitations → page , *System limitations*.
- Accelerate carefully on slippery roads.
- Take your foot off the accelerator pedal when a system is taking control.
- Always adapt your speed and driving style to the visibility, weather, road and traffic conditions.

Trailer hitch

Ball mount holder

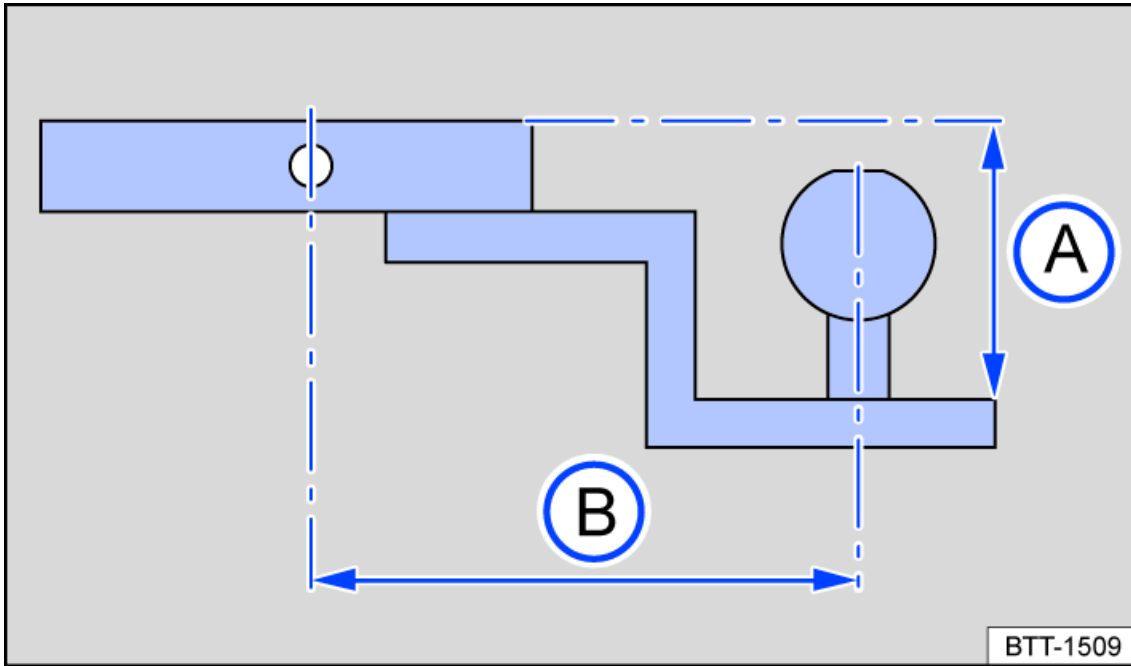

Fig. 140 Dimensions of the ball mount holder and receptacle.

- A** Suspended height of the ball mount.
- B** Distance between socket pin and ball mount.

To pull a trailer you must have installed the necessary cabling, including a socket, and the corresponding trailer hitch. Since pulling a trailer represents a heavy strain for the vehicle towing it, connecting the trailer to the towing vehicle and correct dimensions for the receptacle and the ball mount holder are extremely important in order for the towing vehicle to cope with the strain to be placed on it.

The mount requires a special shape and size of ball mount holder and ball mount. This affects both the suspended height of the ball coupling *fig. 140* **A** and the distance between the socket pin and the ball coupling *fig. 140* **B**.

These dimensions determine the distribution of strain on the receptacle and the connections to the vehicle during towing. When purchasing a ball mount holder and a ball mount, always ensure that these will cope with the requirements.

Dimensions of the ball mount holder

- The suspended height *fig. 140* **A** from the top of the ball mount to the top of the neck must not exceed 50.8 mm (2 inches).
The distance between the socket pin and the ball mount *fig. 140* **B** must not exceed 209.55 mm (8 1/4 inches) from the middle of the ball mount to the middle of the eye of the pin.
The diameter of the ball mount may not exceed 50.8 mm (2 inches).

Ball mounts and holders which do not meet these specifications could damage your car or could fail completely ⇒ ⚠.

Securing cables

In some countries, unbraked and braked trailers must be secured by means of securing or breakaway cables.

Follow the country-specific regulations for using a securing cable.

1. Secure the securing or breakaway cable to the provided ball mount eyelet.
2. Guide the cable through the eyelet and hook it in the karabiner ⇒ ⚠.

WARNING

Incorrect mounting or the use of an unsuitable trailer hitch can lead to the trailer becoming detached from the towing vehicle during the journey, potentially causing accidents and serious injuries or death.

- Only have work on your trailer hitch or the retrofitting of a trailer hitch carried out by an authorized Volkswagen dealer or authorized Volkswagen service facility. Volkswagen recommends contacting an authorized Volkswagen dealer or authorized Volkswagen Service Facility.

WARNING

An improperly secured trailer can cause accidents and serious injuries or death.

- Never drape the securing or breakaway cable of the trailer loosely over the ball mount.

CAUTION

A fitted but unused ball mount holder can increase the risk of injuries in the event of a rear-end collision.

- Always remove the ball mount holder when it is not being used.

NOTICE

Fitting an unsuitable ball mount can cause vehicle damage and invalidation of the operating license.

- Use the ball mount supplied by the factory or a ball mount approved for your vehicle model and its model year. Volkswagen recommends the use of Volkswagen original parts or Volkswagen original accessories, which you can acquire from an authorized Volkswagen dealer or authorized Volkswagen Service Facility.

NOTICE

The vehicle was not designed to tow trailers requiring larger ball mounts than those specified. The use of an unsuitable trailer hitch can cause vehicle damage.

- Never use ball mounts with a diameter that exceeds 50.8 mm (2 inches).
- Never use an adapter in order to use a larger ball mount.
- If necessary, you may use an adapter to enable you to mount a bicycle carrier or similar. Always observe the weight specifications when doing so.
- Make sure that the taillights are not obscured by the use of a bicycle rack or similar equipment.

Retrofitting a trailer hitch

Volkswagen recommends having a trailer hitch retrofitted by an authorized Volkswagen dealer or authorized Volkswagen Service Facility. For example, modifications to the cooling system or the installation of heat shields may be necessary. Volkswagen recommends contacting an authorized Volkswagen dealer or authorized Volkswagen Service Facility.

Mount the trailer hitch in accordance with the instructions supplied.

A retrofitted, non-removable trailer hitch must not cover the label or the lighting system on the rear of the vehicle. Note the country-specific regulations for using a ball mount ⇒ .

WARNING

Improperly or incorrectly connected electrical wires can lead to malfunctions in the entire vehicle electronics system as well as accidents and serious or fatal injuries.

- Never connect the electrical system on a trailer directly to the electrical connectors for the taillights or other unsuitable power sources.
- Only use suitable connectors to connect the trailer.
- If retrofitting the vehicle with a trailer hitch, have the work performed by an authorized Volkswagen dealer or authorized Volkswagen Service Facility. Volkswagen recommends contacting an authorized Volkswagen dealer or authorized Volkswagen Service Facility.

WARNING

Incorrect mounting or the use of an unsuitable trailer hitch can lead to the trailer becoming detached from the towing vehicle during the journey, potentially causing accidents and serious injuries or death.

- Only have work on your trailer hitch or the retrofitting of a trailer hitch carried out by an authorized Volkswagen dealer or authorized Volkswagen service facility. Volkswagen recommends contacting an authorized Volkswagen dealer or authorized Volkswagen Service Facility.

 Only use trailer hitches that are provided for the vehicle model, model year and vehicle equipment by the corresponding manufacturer. Volkswagen recommends the use of Volkswagen original parts or Volkswagen original accessories, which you can acquire from an authorized Volkswagen dealer or authorized Volkswagen Service Facility.

Roof rack

Introduction

Depending on the model, the vehicle may be designed to have a roof rack installed.

Bulky objects can be transported on the vehicle roof using the roof rack.

If you are not sure if your vehicle is designed to have a roof rack installed, check with an authorized Volkswagen dealer or authorized Volkswagen Service Facility. Volkswagen recommends contacting an authorized Volkswagen dealer or authorized Volkswagen Service Facility.

Only use roof racks that are approved by Volkswagen for use with your vehicle.

Do not use or retrofit a roof rack if this is not approved for your vehicle.

WARNING

When transporting large, heavy, long, or flat loads on the roof rack, the vehicle's driving characteristics and aerodynamics change because of the different center of gravity and increased wind resistance. This may cause accidents and serious or fatal injuries.

- Always secure cargo correctly with suitable and undamaged cords, fixation belts or tensioning straps.
- Avoid abrupt and sudden driving and braking maneuvers.
- Always adapt your speed and driving style to the visibility, weather, road and traffic conditions.

WARNING

If the use of a roof rack is not approved for your vehicle or a roof rack that is incompatible with the vehicle is fitted, it may detach and fall from the roof of the vehicle while you are driving. This may cause accidents and serious or fatal injuries.

- Only use roof racks that are approved by Volkswagen for the vehicle.
- Do not fit roof racks if they are not approved for your vehicle.



NOTICE

Installing any type of roof rack onto a vehicle that is not approved for use of a roof rack can cause serious damage.

- Do not fit roof racks if they are not approved for your vehicle.

 Driving with a roof rack fitted increases the air resistance of the vehicle and thus also the fuel consumption. This reduces the potential range of the vehicle. This applies to all roof racks and any objects transported on them, such as bicycles and skis.

Mounting a roof rack

 Please read the introductory information and heed the Warnings and Notice  and  *Introduction*.

For safety reasons, special roof racks are needed to transport luggage, bicycles, surfboards, skis and boats safely. The roof racks for installation on the roof rail in particular are referred to as roof rack bars, and are used as a base supports for direct installation on the vehicle roof.

Only use roof racks that are provided for the vehicle model, model year and vehicle equipment by the corresponding manufacturer.

Volkswagen recommends the use of Volkswagen original parts or Volkswagen original accessories, which you can acquire from an authorized Volkswagen dealer or authorized Volkswagen Service Facility.

Mounting the Roof Rack Bars on the Roof Rail

Mount the roof rack bars in accordance with the supplied installation instructions.

The respective base can be attached after successfully installing the roof rack bars .

Remove the roof rack in the following scenarios

- If the roof rack is no longer needed.
- Before driving through an automatic car wash
- If the height of the vehicle exceeds the maximum height limit, for example in a garage

NOTICE

The height of the vehicle changes when a roof rack is installed and when there is cargo secured on it. The vehicle may be badly damaged if you drive into entrances with low heights, e.g. underpasses and garages.

- Compare the height of the vehicle with the clearance height.

NOTICE

If parts on the roof of your particular vehicle (depending on the vehicle equipment), e.g. the roof antenna, and the trunk lid's range of movement are impaired by the roof rack and the luggage, the vehicle may be damaged.

- Ensure that the roof rack is positioned correctly on the roof and that it will not affect any components of the vehicle.

WARNING

Securing the roof rack and base incorrectly or using them incorrectly may cause the luggage or the entire assembly to come loose from the vehicle roof. This can result in accidents and serious or fatal injuries.

- Always mount the roof rack and base correctly in accordance with the manufacturer's instructions.
- Secure the roof rack only at the locations intended for this.
- Always mount special rack assemblies for bicycles, skis, surfboards, etc. correctly and in accordance with the manufacturer's installation instructions.
- Only use the roof rack and base if they are undamaged and secured correctly.
- Check the roof rack mounts before starting a journey and, if necessary, retighten them after a short distance.
- On long trips, check the threaded connections and fasteners each time you take a break.
- Do not make any modifications or repairs to the roof rack or base.

 A fitted roof rack increases air resistance and therefore may reduce the vehicle's range.

Loading the roof rack

 Please read the introductory information and heed the Warnings and Notice ⇒  and  *Introduction*.

Maximum permissible roof weight

The maximum permissible roof load is 90 kg (200 lbs).

The roof load consists of the weight of the roof rack and the items carried on the roof rack → .

Always check the weight of the roof rack and the items that will be transported on it. Weigh the items if necessary.

When using a roof rack with a low load limit, do not load the rack with the maximum permissible roof load. In this case, only load the roof rack to the weight limit listed in the installation guide.

Distributing the load

Distribute the load evenly and secure it correctly → .

Checking that everything is secure

Once you have fitted the roof rack, drive a short distance and then check all the fasteners. Keep checking them regularly.

WARNING

Exceeding the maximum permitted roof load can result in accidents, damage to the vehicle and serious or fatal injuries.

- Never exceed the specified roof load, the Gross Axle Weight Rating, and the Gross Vehicle Weight Rating of the vehicle.
- Do not exceed the load limit of the roof rack, even if the roof load is below the limit.

WARNING

If loose and incorrectly secured luggage falls off the roof rack, accidents and serious or fatal injuries may occur.

- Use only suitable and undamaged tie-downs, fixing and tensioning straps.

NOTICE

If the trunk lid hits the roof load, the vehicle may be damaged.

- Make sure the trunk lid does not run into the roof load when opening the lid.

Fuel and emissions control system

Safety precautions for handling fuel

WARNING

Handling fuel incorrectly can cause explosions, fires, severe burns, and other injuries.

- Before refueling, switch off the engine, the ignition and your cell phone, as well as other radio equipment.
- To reduce the risk of discharging static electricity, do not enter the vehicle while refueling.
- Make sure that the fuel tank cap is sealed correctly and no fuel is leaking out.
- Note the applicable safety precautions and local regulations for handling fuel.

WARNING

Refueling incorrectly can cause fires, serious or fatal injuries, and vehicle damage.

- Only use fuel that is approved for your vehicle.
- Do not use any fuels containing metal and only use service additives approved by Volkswagen in the respective proportion.
- Immediately remove any fuel that has spilled on vehicle components.

CAUTION

Fuel may leak out of reserve canisters and ignite. This can cause fires and injuries.

- Do not transport any reserve canisters in the vehicle.

 Fuels can contaminate the environment. Collect any leaking operating fluids and dispose of them according to legal regulations.

 The fuel filler flap does not have an emergency release. If necessary, contact an authorized Volkswagen dealer or authorized Volkswagen Service Facility for assistance.

Fuel types and refueling

Introduction

The fuel filler flap is located on the right rear side of the vehicle.

Designation of fuels and fuel standards

 Refer to ⇒  and  *Safety precautions for handling fuel.*



Fig. 141 On the inside of the fuel filler flap: fuel label (general example)

Fuel label

The type of fuel to use depends on the vehicle engine. The factory has placed a fuel information label on the fuel filler flap, which specifies the fuel type to be used for the vehicle *fig. 141*.

In accordance with European Standard DIN EN 16942, the compatibility labels for ethanol content can be found at the following locations:

- On the vehicle, on the fuel information label in the fuel filler flap *fig. 141*.
- On the fuel pumps or nozzles suitable for your vehicle.

The name and limits specify which fuels are suitable for the vehicle. The vehicle must not be refueled with fuels of lower quality or other fuel types ⇒ .

Fuel standards and compatibility

The fuel used must meet one of the following standards. The vehicle must not be refueled with other fuels ⇒ .

If fuel with the specified standards is not available, contact suitably qualified professionals for information about which fuels are suitable for the vehicle. Volkswagen recommends contacting an authorized Volkswagen dealer or authorized Volkswagen Service Facility.

Ethanol content of gasoline types



Fig. 142 Label for gasoline containing 5% ethanol.

E5 stands for gasoline with **E**thanol content of maximum 5%.

Gasoline containing 5% ethanol is available across the EU.



Fig. 143 Label for gasoline containing 10 % ethanol.

E10 stands for gasoline with **E**thanol content of maximum 10 %.

Gasoline containing 10 % ethanol is available across the EU.



Fig. 144 Label for gasoline containing 20 % ethanol.

E20 stands for gasoline with **E**thanol content of maximum 20 %.

Gasoline containing 20% ethanol will only be available in the EU in the future.

Fuel standard:

- EN 228 in the current version.
- DIN EN 228 in the current version.
- Resolucao ANP N° 40 (Brazil) in the current version.
- Resolucion 576/2019 (Argentina) in the current version.
- NOM-016-CRE-2016 (Mexico) in the current version.
- AZS 388-2011 (Azerbaijan) in the current version.

! NOTICE

Refueling with non-standard and non-approved fuels can cause reduced performance and considerable damage to the engine and the fuel system.

- Only use fuels of the named grades that correspond to the fuel information label in the fuel filler flap.

Gasoline

Refer to ⇒  and  *Safety precautions for handling fuel.*

Gasoline types

The fuel information label on the inside of the fuel filler flap provides information about the fuel to be used.

The gasoline types differ in terms of their Anti-Knock Index (AKI) specification, which is given from the formula $(RON+MON) / 2$, or the Research Octane Number (RON) specification. The vehicle may also be fueled with gasoline that has a higher AKI or RON than what is required by the engine. However, this will not improve fuel consumption or engine power.

Arteon, Atlas 2.0 and Jetta GLI: Volkswagen recommends using premium-grade fuel with AKI 91 or RON 95 in order to achieve the specified power and torque.

The fuel label may include multiple types of gasoline, e.g. **AKI 93** (AKI min. 91). The highlighted gasoline type, AKI 93 in this example, is the preferred gasoline type for which the vehicle is designed and optimized. The listed alternative gasoline type, AKI 91 in this example, should only be used if the preferred type, AKI 93 in this example, is not available.

If your vehicle has a gasoline engine, fuel it only with gasoline that does not contain any metal (no lead, manganese or iron) ⇒ .

The most frequently purchased gasoline types in the USA and Canada have the following octane values, which are normally listed on the fuel pump:

- Regular (normal gasoline): AKI 87 to 90 or RON 91.
- Premium (super gasoline): AKI 91 to 93 or RON 95.

Volkswagen recommends using “TOP TIER Detergent Gasoline”, which is available in some regions, for example North America, Central America and South America. For more information on “TOP TIER Detergent Gasoline”, visit the official website at:

<https://www.toptiergas.com>

NOTICE

The use of gasoline that does not meet the minimum requirements for the octane number can impair engine performance. The use of poor-quality gasoline or gasoline with an AKI of under 87 or a RON of under 91 can cause engine damage.

- Only fuel with gasoline that meets or exceeds the specified octane number, Research Octane Number (RON) or Anti-Knock Index (AKI).

Designation of fuels and fuel standards

 Refer to ⇒  and  *Safety precautions for handling fuel.*



Fig. 145 On the inside of the fuel filler flap: fuel label (general example)

Fuel label

The type of fuel to use depends on the vehicle engine. When your vehicle leaves the factory there is a fuel information sticker inside the tank flap with notes about the minimum required fuel type for your vehicle *fig. 145*.

The compatibility labels can be found at the following locations:

- On the vehicle, on the fuel information label in the fuel filler flap *fig. 145*.
- On the fuel pumps or nozzles suitable for your vehicle.

The name specifies which fuels are suitable for the vehicle. This is a minimum requirement. The vehicle must not be refueled with fuels of lower quality or other fuel types ⇒ .

Fuel standards and compatibility

The fuel used must meet one of the following standards. The vehicle must not be refueled with other fuels ⇒ .

If fuel with the specified standards is not available, contact suitably qualified professionals for information about which fuels are suitable for the vehicle. Volkswagen recommends contacting an authorized Volkswagen dealer or authorized Volkswagen Service Facility.

Gasoline and methanol mixture

- AKI 87 or higher.
- Maximum 3% methanol.

Gasoline and ethanol mixture

- AKI 87 or higher.
- Maximum 15% ethanol.

Gasoline and MTBE mixture

- AKI 87 or higher.
- Maximum 15% MTBE.

NOTICE

Refueling with non-standard and non-approved fuels can cause reduced performance and considerable damage to the engine and the fuel system.

- Only use fuels with the specified standards that correspond to the fuel information label in the fuel filler flap.

Exhaust system

Introduction

The exhaust-relevant components reduce exhaust emissions:

- Catalytic converter ⇒ *Catalytic converter*.
- Particulate filter (depending on the vehicle equipment) ⇒ *Particulate filter*.

WARNING

If the engine runs in enclosed spaces, poisonous gases may enter the vehicle interior. This can cause serious injuries and death due to asphyxiation.



- Never start the engine in confined spaces.
- Do not allow the engine to run in confined spaces.
- Do not leave your vehicle unattended while the engine is running.

WARNING

The parts of the exhaust system become very hot and can ignite flammable materials, for example shrubs, leaves, dry grass or spilled fuel. This can lead to a fire and cause accidents and serious or fatal injuries.

- Never park the vehicle in such a way so that the exhaust system components come into contact with flammable materials under the vehicle.
- Never use additional undercoating or corrosion protection for exhaust pipes, catalytic converters, heat shields, or particulate filters.

Catalytic converter

 Please read the introductory information and heed the Warnings and Notice \Rightarrow  and  *Safety precautions for handling fuel.*



To ensure that the exhaust system and the engine catalytic converter can work correctly for a long time, observe the following

- Only refuel with fuel permitted for the vehicle.
- Never drive until the fuel tank is completely empty.
- Never add too much engine oil \Rightarrow *Checking the engine oil level and adding oil.*
- Do not tow-start the vehicle; use jump-start assistance instead \Rightarrow *Start the engine.*

If there are engine misfires, loss of power, or poor engine operation while driving, reduce the speed immediately and have the vehicle checked by suitably qualified professionals \Rightarrow *Troubleshooting.* Volkswagen recommends contacting an authorized Volkswagen dealer or authorized Volkswagen Service Facility. Otherwise, uncombusted fuel could be present in the exhaust system and then enter the atmosphere. The catalytic converter may also be damaged from overheating.

 The exhaust may smell like sulfur when the emissions control system is running correctly.

Particulate filter

 Please read the introductory information and heed the Warnings and Notice \Rightarrow  and  *Safety precautions for handling fuel.*

Function



The particulate filter depends on the vehicle equipment and filters out soot from the exhaust gas.

Regeneration



With normal vehicle usage, the filter cleans itself. If the filter is unable to clean itself, e.g. if you only make short trips for an extended period of time, the filter can become blocked with soot. The particulate filter needs to be cleaned (regenerated).

Noises, light odors, and increased engine speeds may occur during the regeneration. The radiator fan may continue to run while driving and after turning off the engine.

To assist in particulate filter regeneration, Volkswagen recommends avoiding driving short distances too frequently.

 The soot in the particulate filter is burned periodically at high temperatures. The yellow  indicator light does not turn on during a periodic regeneration.

Troubleshooting

 Please read the introductory information and heed the Warnings and Notice \Rightarrow  and  *Safety precautions for handling fuel.*

If the engine does not run smoothly and malfunctions

If the engine does not run smoothly or malfunctions while driving, it can indicate poor fuel quality.

1. Reduce your speed immediately.
2. Drive with a moderate RPM and low engine load to the nearest suitably qualified professional. Volkswagen recommends contacting an authorized Volkswagen dealer or authorized Volkswagen Service Facility.
3. If these symptoms occur directly after refueling, stop the engine immediately to prevent subsequent damage.
4.  **Do not continue driving!** Contact an authorized Volkswagen dealer or authorized Volkswagen Service Facility for assistance.

Particulate filter clogged with soot

The yellow indicator light turns on.

The particulate filter is clogged with soot and a regeneration is necessary.

Prerequisite for the regeneration drive: The engine is at operating temperature.

For gasoline engines

1.0 l to 1.8 l

1. Drive at a speed of between approx. 50 km/h and 120 km/h (approx. 30 mph and 75 mph).

The resulting temperature increase burns off the soot in the filter.

2. Only end the regeneration drive once the indicator light turns off.
3. If the indicator light is still illuminated after driving for approximately 40 minutes, drive immediately to suitably qualified professionals for assistance. Volkswagen recommends contacting an authorized Volkswagen dealer or authorized Volkswagen Service Facility.

2.0 l and 3.0 l

1. Drive at a speed of at least 80 km/h (approx. 50 mph).
2. Take your foot completely off the accelerator pedal for a few seconds to let the vehicle roll when a gear is engaged.
3. Repeat this process of accelerating and letting the vehicle roll until the indicator light turns off.
4. If the indicator light does not turn off after some time, immediately consult an authorized Volkswagen dealer or authorized Volkswagen Service Facility. Volkswagen recommends contacting an authorized Volkswagen dealer or authorized Volkswagen Service Facility.

Exhaust-related malfunction

The yellow indicator light turns on.

An exhaust-related component is malfunctioning, which could damage the vehicle.

1. Contact a suitably qualified professional and have the engine and the exhaust system checked. Volkswagen recommends contacting an authorized Volkswagen dealer or authorized Volkswagen Service Facility.

Misfire

The indicator light flashes yellow.

There is misfire which could damage the vehicle.

1. Contact a suitably qualified professional and have the engine and the exhaust system checked. Volkswagen recommends contacting an authorized Volkswagen dealer or authorized Volkswagen Service Facility.

WARNING

Sudden braking or driving maneuvers, e.g. if an indicator light turns on or if the engine does not run smoothly, can cause

accidents. This can result in serious injury or death.

- Always adapt your speed and driving style to the visibility, weather, road and traffic conditions.
- Follow the road traffic laws and regulations that apply in the country you are driving in.

 If the indicator lights are on or flashing, it is likely that there is an engine malfunction and that fuel consumption will increase.

Do it yourself

Vehicle tool kit

Introduction

When securing the vehicle in the event of a vehicle breakdown, follow the legal regulations applicable in the respective country.

WARNING

A loose tire mobility set, spare wheel, compact spare wheel or loose vehicle tool kit can be thrown through the vehicle interior during sudden driving or braking maneuvers or in the event of an accident. This could result in serious or fatal injuries.



- Always make sure the vehicle tool kit, tire mobility set, and spare wheel or compact spare wheel are secured in the luggage compartment.

WARNING

Working with an unsuitable or damaged vehicle tool kit may result in accidents. This could result in serious or fatal injuries.

- Never work with an unsuitable or damaged vehicle tool kit.
- Seek assistance from an authorized Volkswagen dealer or authorized Volkswagen Service Facility if there is no suitable vehicle tool kit available.



Placement

 Please read the introductory information and heed the Warnings and Notice ⇒  [Introduction](#).

There are a number of different storage locations for the tool box in the vehicle, such as under the luggage compartment floor or in a side storage compartment of the luggage compartment.

Depending on the equipment variant, the vehicle may contain a loose box with the vehicle tool kit in the luggage compartment. This supplied vehicle tool kit is intended for a possible winter tire change and doesn't have to be permanently stored in the vehicle → page , *Stowing luggage and cargo*.

Vehicle tool kit components

 Please read the introductory information and heed the Warnings and Notice ⇒  [Introduction](#).

The scope of the tool box depends on the country and equipment. The following information describes the full scope of items that may be included.

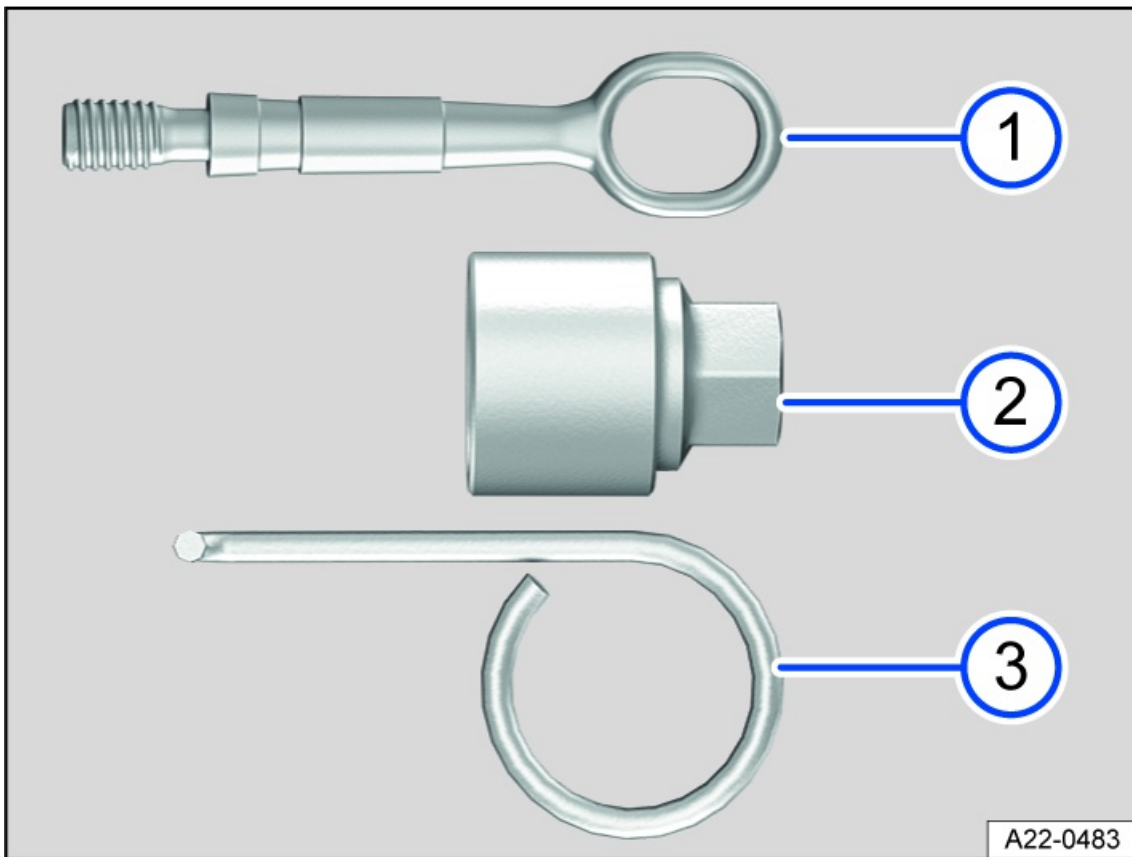

Fig. 146 Vehicle tool kit components (general example).

- ① Towing eye that can be screwed in.
- ② Adapter for the anti-theft wheel bolt. Volkswagen recommends always keeping the adapter for the wheel bolts in the vehicle with the vehicle tool kit. The code number for the wheel bolt lock is stamped on the front of the adapter. A replacement adapter can be ordered based on this number if the adapter is lost. Note the wheel bolt lock code number and keep it separate from the vehicle.
- ③ Extraction hook for removing the center wheel covers, wheel hub covers, or wheel bolt covers.

Additional vehicle tool kit

Depending on the vehicle equipment, the additional vehicle tool kit may include a jack. The additional vehicle tool kit with jack does not always have to be carried in the vehicle.

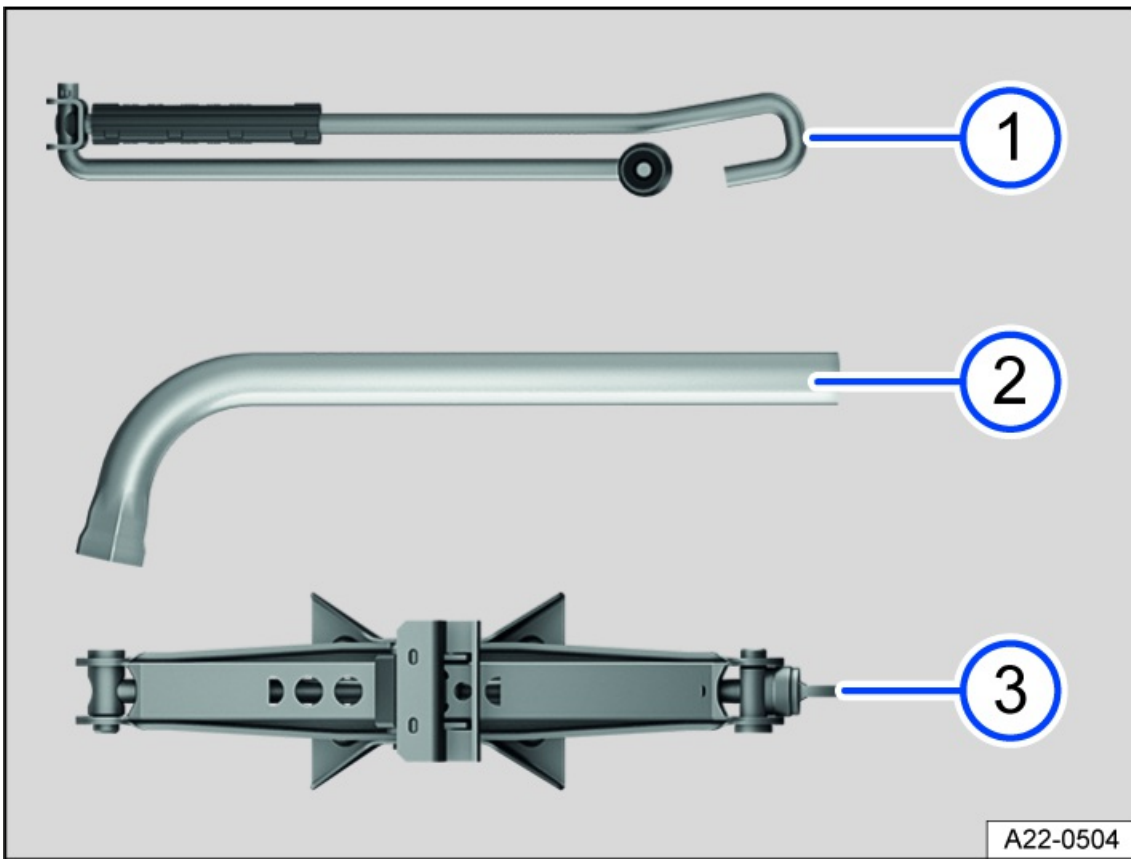



Fig. 147 Additional vehicle tool kit components (general example).

- ① Crank.
- ② Lug wrench for loosening and tightening wheel bolts.
- ③ Vehicle jack.

 If used, crank the vehicle jack back down so that it can be securely stowed in the vehicle.

Jack maintenance

If a jack is included in the scope of the vehicle tool kit, the jack is generally not subject to any maintenance cycles.

1. If necessary, apply universal lubricant to the jack.

Tire Pressure Gage

In some countries, there may also be a tire pressure gauge in the vehicle.

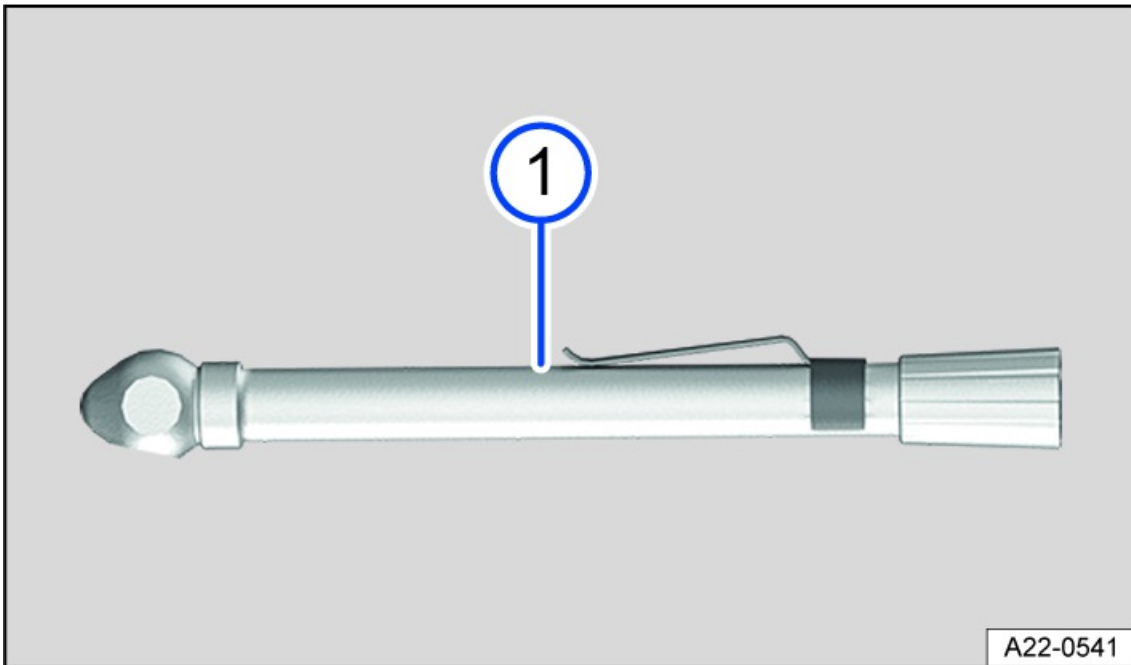

Fig. 148 Additional vehicle tool kit component (general example).

① Tire pressure tester (depending on the country).

Windshield wipers

Putting the windshield wipers in the service position

In the service position, the wiper arms can be lifted off of the windshield.



Fig. 149 Windshield wipers in service position (general example).

Activate the service position using the windshield wiper lever

1. Close the hood, driver and front passenger door.
2. Switch the ignition on and off again.

3. Operate one-tap wiping ⇒ *Operating the windshield wiper lever*.

Activate the service position using the exit menu

The service position of the wiper blades can also be activated in the exit menu for a limited period of time. To do this, the ignition must be switched off.

Lifting the windshield wiper arms

1. Move the windshield wiper arms into the service position before lifting ⇒ .
2. Only hold and lift wiper arms in the area where they attach to the wiper blade.

Placing the windshield wiper arms back

1. Before driving, carefully place the wiper arms back against the windshield, holding them only in the area where they attach to the wiper blade.
2. To return the wiper arms to the home position, operate “one-tap wiping” when the ignition is switched on ⇒ *Operating the windshield wiper lever*.

The wiper arms move back to the original position.

NOTICE

Failing to take care when working on the wiper arms can damage the hood, windshield, or wiper arms.

- Lift the wiper arms with care, and only in the service position.
- Never open the hood when the wiper arms are raised up.
- Always place the wiper arms carefully against the windshield before driving.

Cleaning and changing wiper blades

Wiper blades with a graphite coating are installed at the factory. The graphite coating allows the wiper blade to glide easily over the window. A damaged graphite coating creates an increased noise level when wiping the window.

- Check the condition of the wiper blades regularly.
- If wiper blades are rubbing, replace them if they are damaged or clean them if they are dirty ⇒ .

Damaged wiper blades should be replaced immediately. Wiper blades can be obtained from suitably qualified professionals. Volkswagen recommends contacting an authorized Volkswagen dealer or authorized Volkswagen Service Facility.

Cleaning the wiper blades

1. Put the wiper arms into the service position ⇒ *Putting the windshield wipers in the service position*.
2. Lift the wiper arms and only hold in the area where they attach to the wiper blade.
3. Clean the wiper blades carefully with a damp sponge ⇒ .
4. Place the wiper arms carefully on the windshield.

Changing the windshield wiper blades

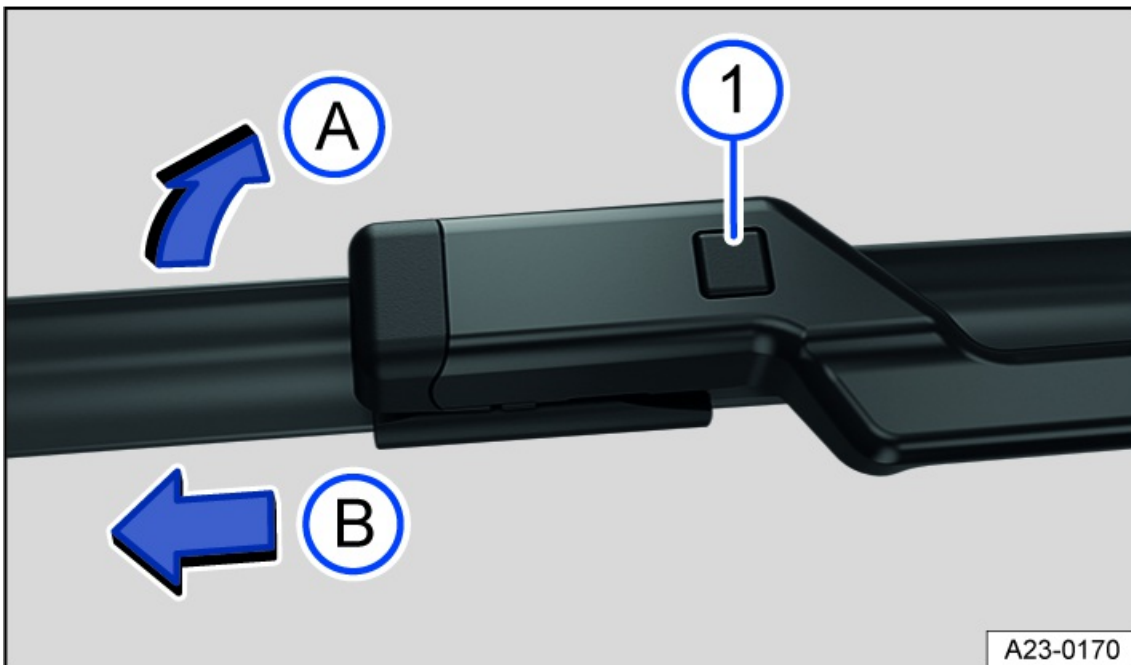

A23-0170

Fig. 150 Changing the windshield wiper blades.

① Wiper blade release button.

1. Move the windshield wiper arms into the service position before lifting ⇒ *Putting the windshield wipers in the service position.*
2. Lift the wiper arms and only hold in the area where they attach to the wiper blade.
3. Press and hold the release button *fig. 150 ①*.
4. Tilt the wiper blade toward the wiper arm *fig. 150 ① A* while removing it in the direction of the arrow *① B*. You may need to use more force to do this.
5. Slide a new wiper blade with the same length and design onto the wiper arm in the opposite direction to the arrow until it engages *fig. 150 ① B*. For this to work, the wiper blade has to be folded out *fig. 150 ① A*.
6. Place the wiper arms carefully on the windshield.

Changing the rear window wiper blade

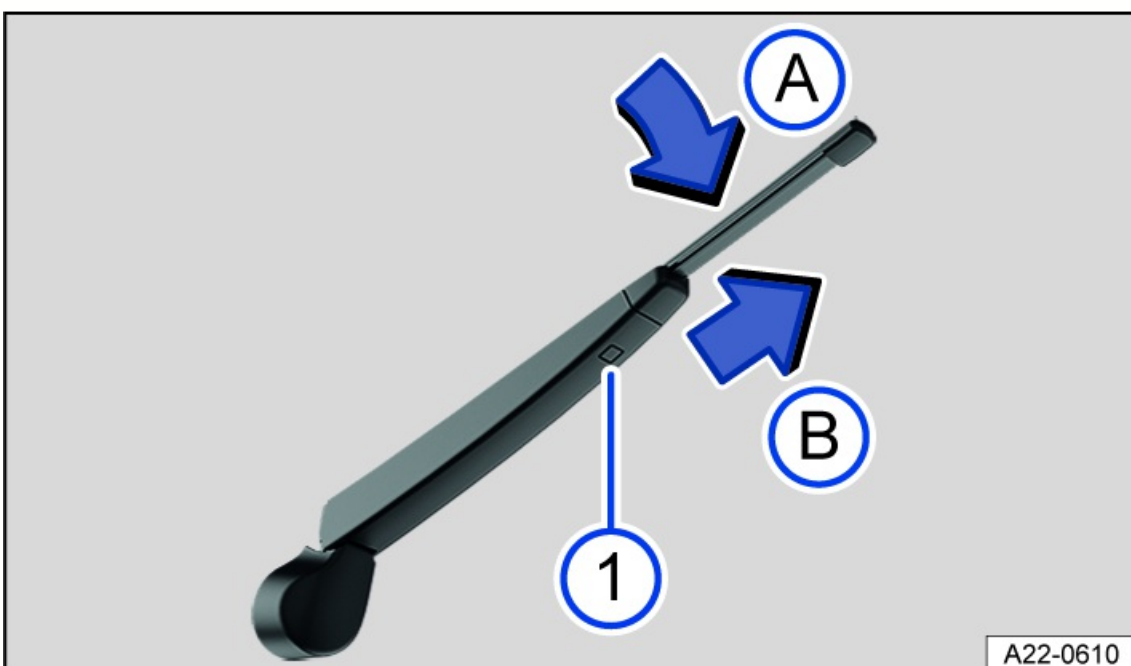

A22-0610

Fig. 151 Changing the rear window wiper blade.

① Wiper blade release button.

1. To lift a windshield wiper arm, hold it only in the area where it attaches to the wiper blade.
2. Lift the wiper arm and fold it out.
3. Press and hold the release button *fig. 151* **1**.
4. Tilt the wiper blade toward the wiper arm *fig. 151* **A** while removing it in the direction of the arrow **B**. You may need to use more force to do this.
5. Slide a new wiper blade with the same length and design onto the wiper arm in the opposite direction to the arrow until it engages *fig. 151* **B**. For this to work, the wiper blade has to be folded out *fig. 151* **A**.
6. Place the wiper arm carefully on the rear window.

WARNING

Worn or dirty wiper blades reduce visibility and increase the risk of accidents and serious injuries.

- Always clean dirty wiper blades.
- Always replace wiper blades if they are damaged or worn and are no longer cleaning the window glass sufficiently.

NOTICE

Cleaning wiper blades or door windows with unsuitable cleaning agents may cause damage.

- Do not clean the wiper blades and windshield and windows with fuel, nail polish remover, paint thinner, or other similar fluids.
- Do not clean the wiper blades with rough sponges or other sharp objects.

 If there is wax residue on the windshield and rear window from car wash systems and other products, this can cause the windshield wipers to rub. Remove any wax residue with a special cleaner or cleaning towels.

Exterior lighting

Exterior lighting using LED technology

The exterior lighting uses LED technology. It is not possible to change LEDs by yourself. The malfunction of individual LEDs may be an indication that more will malfunction. If this is the case, have the lights checked and replaced if necessary by an authorized Volkswagen dealer or authorized Volkswagen Service Facility. Volkswagen recommends contacting an authorized Volkswagen dealer or authorized Volkswagen Service Facility.

Driving with exterior lighting that is inoperative may be against the law.

WARNING

If the vehicle lighting is not used appropriately for the weather conditions, the road will not be illuminated sufficiently. The vehicle will not be visible to other road users or will be difficult to see. This can cause accidents and serious or fatal injuries.

- Regularly check the lighting equipment of the vehicle.
- Have the vehicle lighting system repaired immediately, when necessary.

Replacing fuses

Introduction

Due to the constant development of the vehicle, equipment-dependent fuse allocations, and the combined protection of multiple electrical equipment items using one fuse, a complete overview of the fuse layout is not available at the time of print. Detailed information about fuse allocations can be obtained from suitably qualified professionals. Volkswagen recommends contacting an authorized Volkswagen dealer or authorized Volkswagen Service Facility.

Generally, multiple electrical equipment items can be protected together through by fuse. On the other hand, some equipment items may use multiple fuses.

Only replace fuses if the cause for the malfunction has been fixed.

1. If a new fuse blows again after a short time, have the electrical system checked by suitably qualified professionals. Volkswagen recommends contacting an authorized Volkswagen dealer or authorized Volkswagen Service Facility.

WARNING

The high voltage in the electrical system may cause electric shocks and severe burns. Contact with electric wires in the ignition system may result in serious or fatal injuries.

- Never touch the electrical wires in the ignition system.

WARNING

Using unsuitable fuses, repairing fuses or bridging a circuit without fuses can lead to serious damage or a fire in the vehicle. This could result in serious or fatal injuries.

- Replace fuses only with fuses of same rating and size. Make sure that the color and label are identical to the faulty fuse.
- Never repair fuses.
- Never use metal strips, paper clips or similar objects as substitutes for fuses.

NOTICE

Changing a fuse when the ignition is switched on, the engine is running, the light is switched on, or other electrical equipment is switched on could cause damage to the electrical system.

- Switch off the engine and turn off the light and other electrical equipment.
- Make sure that the engine cannot be started while a fuse is being replaced.

NOTICE

If a fuse is replaced by another fuse with a higher amp rating, this could also damage the vehicle's electrical system in another location.

- Never replace a fuse with a fuse that has a higher current rating.

NOTICE

Dirt and moisture in the fuse boxes can damage the electrical system.

- Protect open fuse boxes from dirt and moisture.

- Avoid short circuits in the electrical system.
- Check that the fuse box covers are tightly sealed again and are not damaged.

 There are other fuses in the vehicle. These should only be replaced by an authorized Volkswagen dealer or authorized Volkswagen Service Facility qualified in this respect. Volkswagen recommends contacting an authorized Volkswagen dealer or authorized Volkswagen Service Facility.

Fuses in the hood space

 Please read the introductory information and heed the Warnings and Notice \Rightarrow  and  *Introduction*.

Opening the fuse box in the hood space

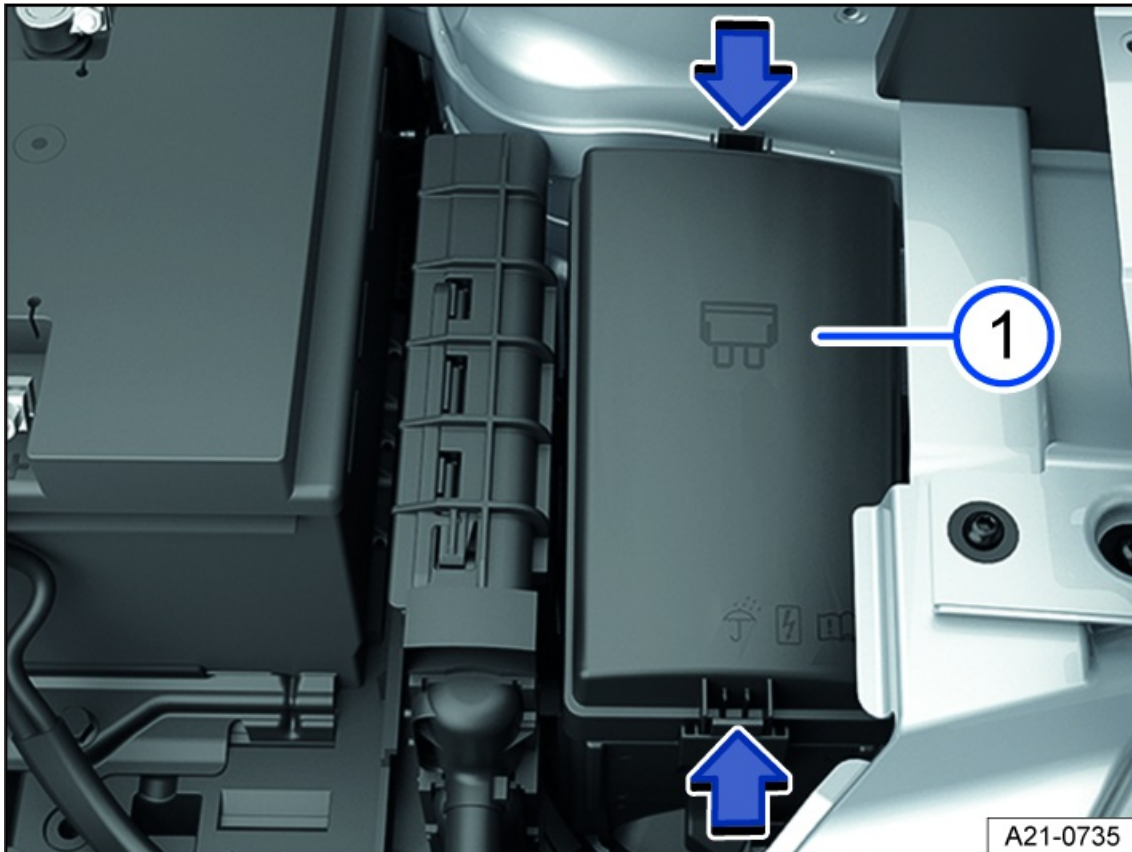



Fig. 152 In the hood space: fuse box (general example).

 Fuse box cover.

The plastic pliers for removing fuses can be found on the inside of the fuse box cover or on the fuse panel.



Removing the cover

1. Open the hood.
2. Press the catches in the direction of the arrow to unlock the fuse box cover *fig. 152* .
3. Remove the cover upward.

Fitting the cover

1. Place the cover onto the fuse box.
2. Push the cover downwards until it audibly clicks into place on both sides.

Overview of Fuses in the Hood Space

 Please read the introductory information and heed the Warnings and Notice \Rightarrow  and  *Introduction*.

The overview shows the fuse positions of the electrical equipment relevant to the driver. The first column of the overview contains the fuse location; the other columns indicate the rated current, the fuse version, and the protected electrical equipment.

Depending on the country and equipment of the vehicle, there may be deviations from the fuse numbers and slots listed in the overview. If necessary, ask for the exact fuse assignment from suitably qualified professionals. Volkswagen recommends contacting an authorized Volkswagen dealer or authorized Volkswagen Service Facility.

Fuse assignment

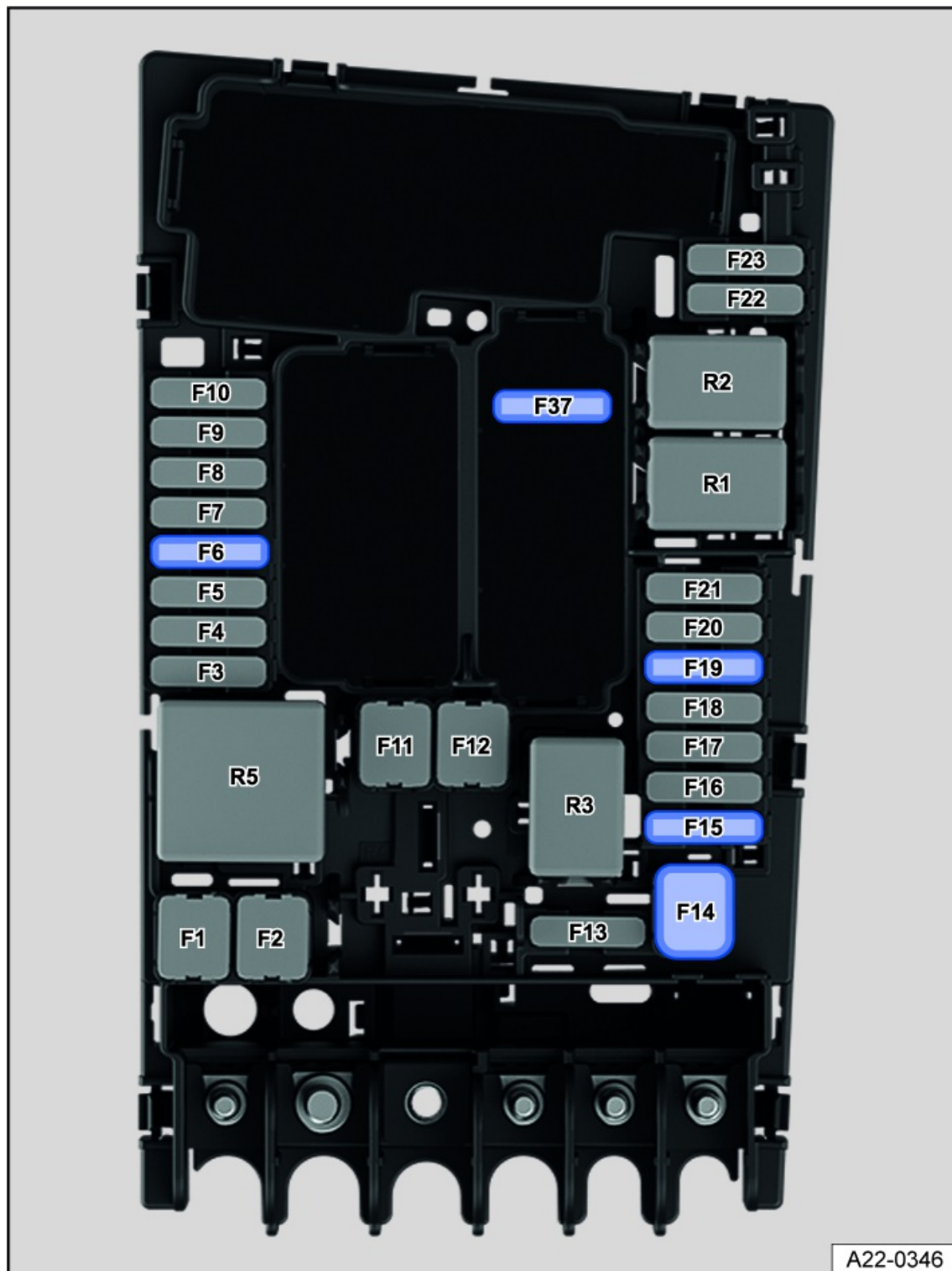

Fig. 153 In the hood space: Fuse locations.

Fuse location *fig. 153*:

F6 7.5 Amp, ATO®, brake light sensor.

F15 15 Amp, ATO®, horn.

F19 30 Amp, ATO®, windshield wipers.

Fuses in the instrument panel

📖 Please read the introductory information and heed the Warnings and Notice ⇒ ⚠️ and ⚠️ Introduction.

Open and close the fuse box in the instrument panel



Fig. 154 On the driver side in the instrument panel: fuse box cover.

Removing the cover

1. Reach behind the cover and pull it off in the direction of the arrow *fig. 154*.

Fitting the cover

1. Press the storage compartment into the mounts in the instrument panel until you hear the catch engage on both sides.
2. Close the storage compartment.

Overview of the Fuses in the Instrument Panel

📖 Please read the introductory information and heed the Warnings and Notice ⇒ ⚠️ and ⚠️ Introduction.

The overview shows the fuse positions of the electrical equipment relevant to the driver. The first column of the overview contains the fuse location; the other columns indicate the rated current, the fuse version, and the protected electrical equipment.

Depending on the country and equipment of the vehicle, there may be deviations from the fuse numbers and slots listed in the overview. If necessary, ask for the exact fuse assignment from suitably qualified professionals. Volkswagen recommends contacting an authorized Volkswagen dealer or authorized Volkswagen Service Facility.

Fuse assignment

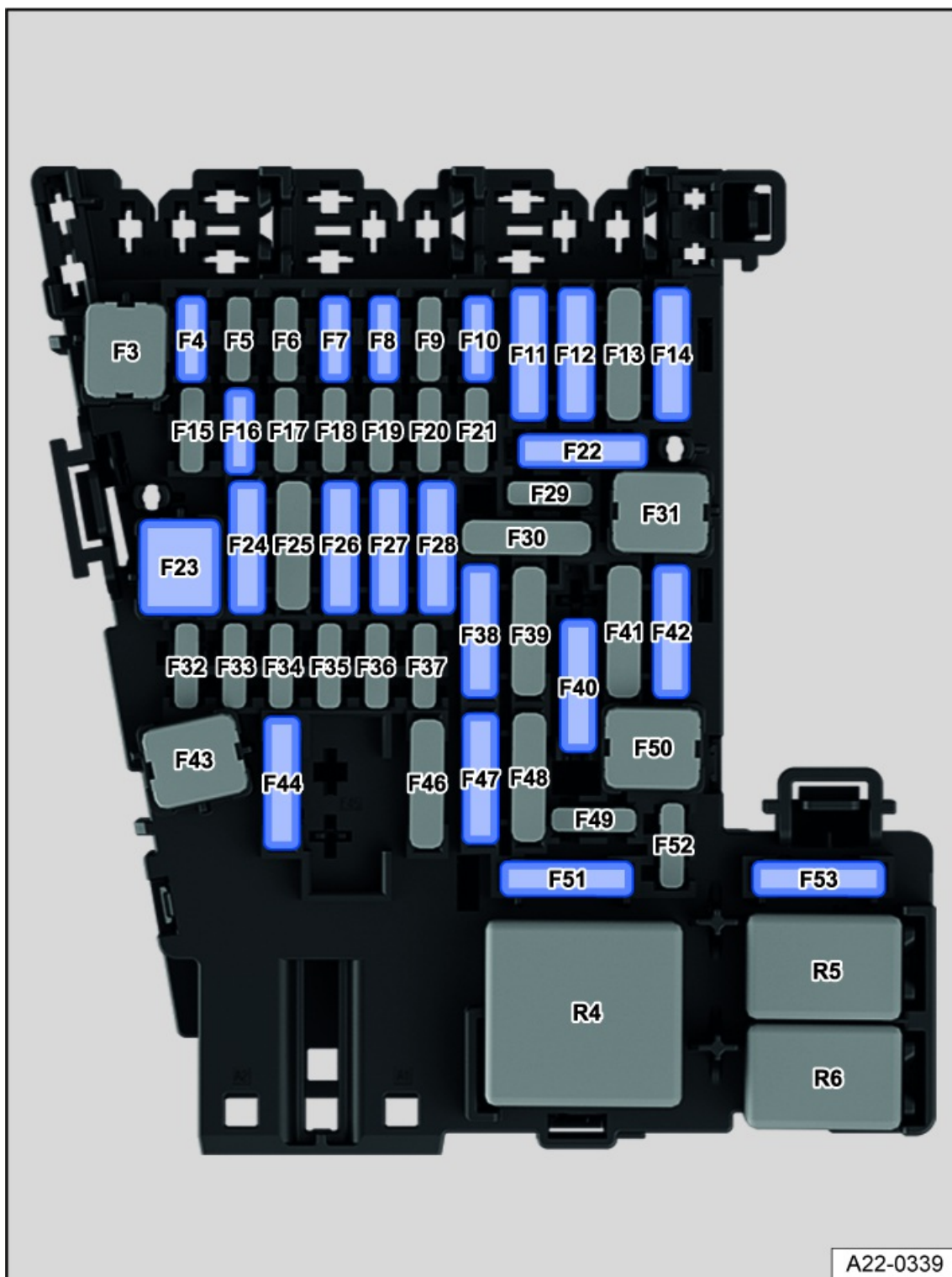

Fig. 155 Fuse assignment in the instrument panel.

Fuse locations *fig. 155*:

- F4** **7.5 Amp, MINI®**, anti-theft alarm system.
- F6** **10 Amp, ATO®**, automatic transmission selector mechanism.
- F7** **10 Amp, MINI®**, climate control bar, rear window defroster relay.
- F8** **7.5 Amp, MINI®**, dipped beam light switch, rain/light sensor, electronic parking brake.
- F10** **7.5 Amp, MINI®**, Display, Infotainment system control panel.
- F11** **40 Amp, ATO®**, exterior lighting on the left side.
- F12** **20 Amp, ATO®**, Infotainment system.

- F14** **40 Amp, ATO®**, blower regulator.
- F16** **7.5 Amp, MINI®**, telephone.
- F23** **20 Amp, JCASE®**, power sunroof.
- F24** **40 Amp, ATO®**, exterior lighting on the right side.
- F26** **30 Amp, ATO®**, seat heating.
- F27** **30 Amp, ATO®**, interior lighting.
- F40** **20 Amp, ATO®**, cigarette lighter, sockets. Note the installation position, factory-standard fuse location as shown in the illustration.
- F42** **40 Amp, ATO®**, central locking system.
- F47** **15 Amp, ATO®**, rear window wiper.
- F51** **25 Amp, ATO®**, rear seat heating.
- F53** **30 Amp, ATO®**, rear window defroster.

Fuse locations in vehicles with a factory-installed trailer hitch:

- F22** **15 Amp, ATO®**, trailer charging cable.
- F28** **25 Amp, ATO®**, left trailer control module.
- F38** **25 Amp, ATO®**, right trailer control module.
- F44** **15 Amp, ATO®**, trailer control module.

 Power windows and seats can be protected by circuit breakers or control modules, which switch back on automatically several seconds after correcting the overload, for example when door windows are frozen shut.

Replacing blown fuses

 Please read the introductory information and heed the Warnings and Notice ⇒  and  *Introduction*.

Preparations

1. Switch off the ignition, lights and all electrical equipment.

Detecting blown fuses

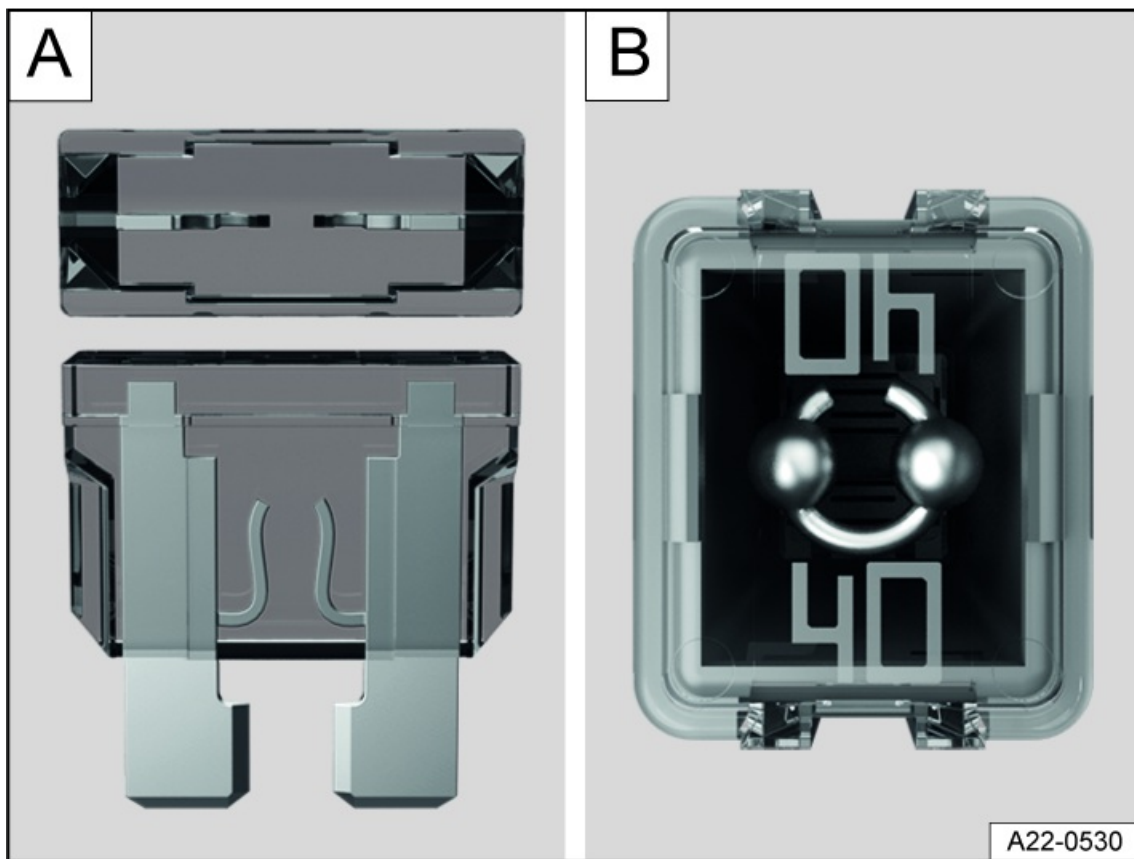

Fig. 156 Blown fuse (general example).

- A blown flat connector fuse (ATO[®], MINI[®]) has metal strips that have burned through, which you can see through the transparent housing from above and from the side [fig. 156 A](#).
- A blown block fuse (JCASE[®]) is recognizable by the melted metal strip seen through the transparent housing from above [fig. 156 B](#).

Fuse versions

- Standard flat connector fuse (ATO[®]).
- Small flat connector fuse (MINI[®]).
- Block fuse (JCASE[®]).

Fuse color codes

Fuses (ATO[®] - MINI[®]).

Color *Current rating*

Black 1 A

Violet 3 A

Light brown 5 A

Brown 7.5 A

Red 10 A

Blue 15 A

Yellow 20 A

White or transparent 25 A

Green 30 A

Orange 40 A

Red 50 A

Fuses (JCASE®)

Yellow 20 A

Green 30 A

Orange 40 A

Red 50 A

Blue 60 A

Replacing fuses



Fig. 157 Plastic pliers for removing or inserting a fuse (general example).

1. If present, remove the plastic pliers from either the fuse box or the cover of the relevant fuse box *fig. 157*.
2. Depending on the design of the fuse, slide the appropriately sized clamp on the plastic pliers onto the fuse from above or from the side.
3. Remove the fuse.
4. If a fuse is blown, replace with a fuse with the same rating (same color and same label) and the same size ⇒ ⚠.
5. After inserting the new fuse, place the plastic pliers back in the cover, if necessary.
6. Reinstall the cover or close the fuse box cover.

⚠ NOTICE

If a fuse is replaced by a fuse with a higher current rating, this could damage the electrical system in another location.

- Never replace a fuse with a fuse that has a higher current rating.

Jump-starting

Introduction

For technical reasons the vehicle must not be tow-started ⇒ . If the engine cannot start because the 12 V vehicle battery is dead, the 12 V vehicle battery on another vehicle can be used to start your vehicle.

For vehicles with a 12 V vehicle battery in the vehicle interior or luggage compartment, the jumper cables may only be connected to the jump-start points in the hood space.

WARNING

Using jumper cables incorrectly and performing a jump-start incorrectly could cause the 12 V vehicle battery to explode. Serious injuries may result.

- Always read and heed the warnings and safety precautions before working on the 12 V vehicle battery ⇒  [Introduction](#).
- Never confuse the positive battery terminal with the negative battery terminal.
- Never jump-start a vehicle with a frozen or thawed 12 V vehicle battery.

WARNING

During a jump-start, a highly explosive gas mixture builds up at the 12 V vehicle battery. Sparks produced during a jump-start could ignite the flammable gas. Serious injuries may result.



- Always keep fires, sparks, open flames, and lit cigarettes far away from the 12 V vehicle battery.
- Avoid discharging static electricity near the 12 V vehicle battery.

NOTICE

Tow-starting can cause severe damage to the vehicle.

- Jump-start the vehicle to start the engine.

Preparing to jump-start

 Please read the introductory information and heed the Warnings and Notice ⇒  and  [Introduction](#). If the engine cannot be started because the 12 V vehicle battery is drained, another vehicle can jump-start it.

NOTICE



A drained 12 V vehicle battery can freeze at temperatures around approx. 0 °C (approx. +32 °F), suffer damage and fail.

- Always replace a frozen or thawed 12 V vehicle battery.

Preparations

Observe the following for jump-starting:

- Wear suitable eye protection and safety gloves ⇒ .
- Pay attention to the operating instructions provided by the manufacturer of the jump-start cables.

- Open the hood.
- Always use a jumper cable with fully insulated terminal clamps and without any insulation defects for jump-starting ⇒ 
- Ensure that there is sufficient distance between the vehicle providing the jump-start and the vehicle receiving the jump-start. If metallic parts of the vehicles come into contact with each other, even just connecting the positive battery terminal is enough to cause current to flow ⇒ .
- Make sure the terminal clamps have sufficient contact with metal.

WARNING

Performing a jump-start incorrectly can cause the 12 V vehicle battery to explode, which can cause serious injuries.

- Always wear suitable eye protection and safety gloves.
- Never lean over the 12 V vehicle battery.
- Always connect the positive cable first and then the negative cable.
- Never connect the negative terminal to parts of the fuel system or to the brake lines.
- Ensure that there is no contact between the non-insulated parts of the terminal clamps.
- Make sure the cable insulation is free from any defects.
- Make sure that the cable that is connected to the positive battery terminal on the 12 V vehicle battery does not come into contact with any vehicle components that conduct electricity.

Jumper cable

So that vehicles can be jump-started and can jump-start others, an appropriate jumper cable is required.

The cable cross-section of the jumper cables must be at least 25 mm² (0,038 in²). The cable cross-section of the jumper cables for vehicles with diesel engines must be at least 35 mm² (0.054 in²).

Vehicle Receiving Jump-start

1. Check that the discharged 12 V vehicle battery is properly connected to the 12 V vehicle electrical system.
2. If a 12 V vehicle battery with a viewing window has been installed, check the color of the viewing window. If the viewing window is light yellow or has no color, do not perform a jump-start; instead, contact an authorized Volkswagen dealer or authorized Volkswagen Service Facility.

Vehicle to be Jump-started



1. Pay attention to the operating instructions provided by the vehicle manufacturer.
2. Check that the battery providing the jump-start has the same voltage (12 V) and approximately the same battery capacity as the dead 12 V vehicle battery. Pay attention to the information printed on the battery of the vehicle providing the jump-start.

NOTICE

To reduce the risk of damage to the electrical system due to short-circuiting, please note the following:

- Always connect the jumper cables as described.
- Avoid contact between the vehicles.

Connecting the Jumper Cable

 Please read the introductory information and heed the Warnings and Notice ⇒  and  Introduction.

Ground jump-start point

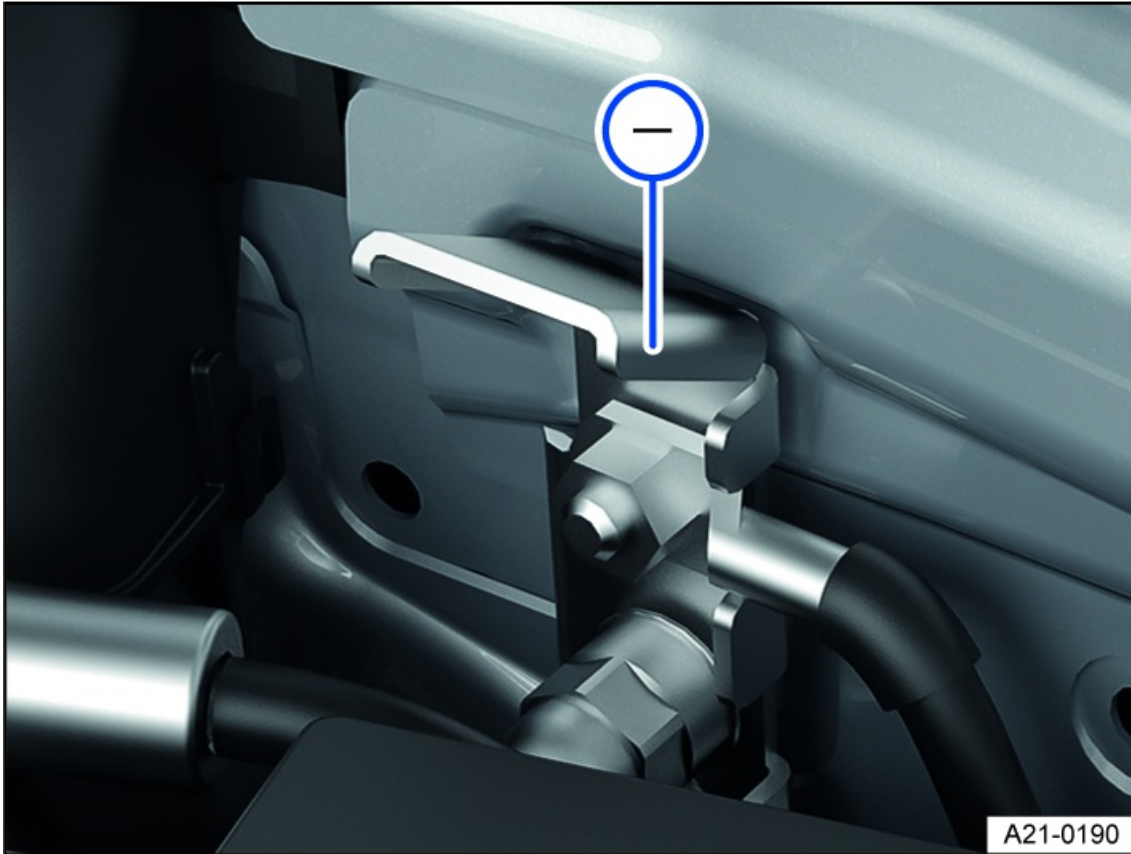

Fig. 158 In the hood space: Negative terminal jump-start point.

- The jump-start point (negative terminal) is for connecting the black jumper cable.

The vehicle can give and receive a jump-start using this negative terminal jump-start point.

Connecting the jumper cables

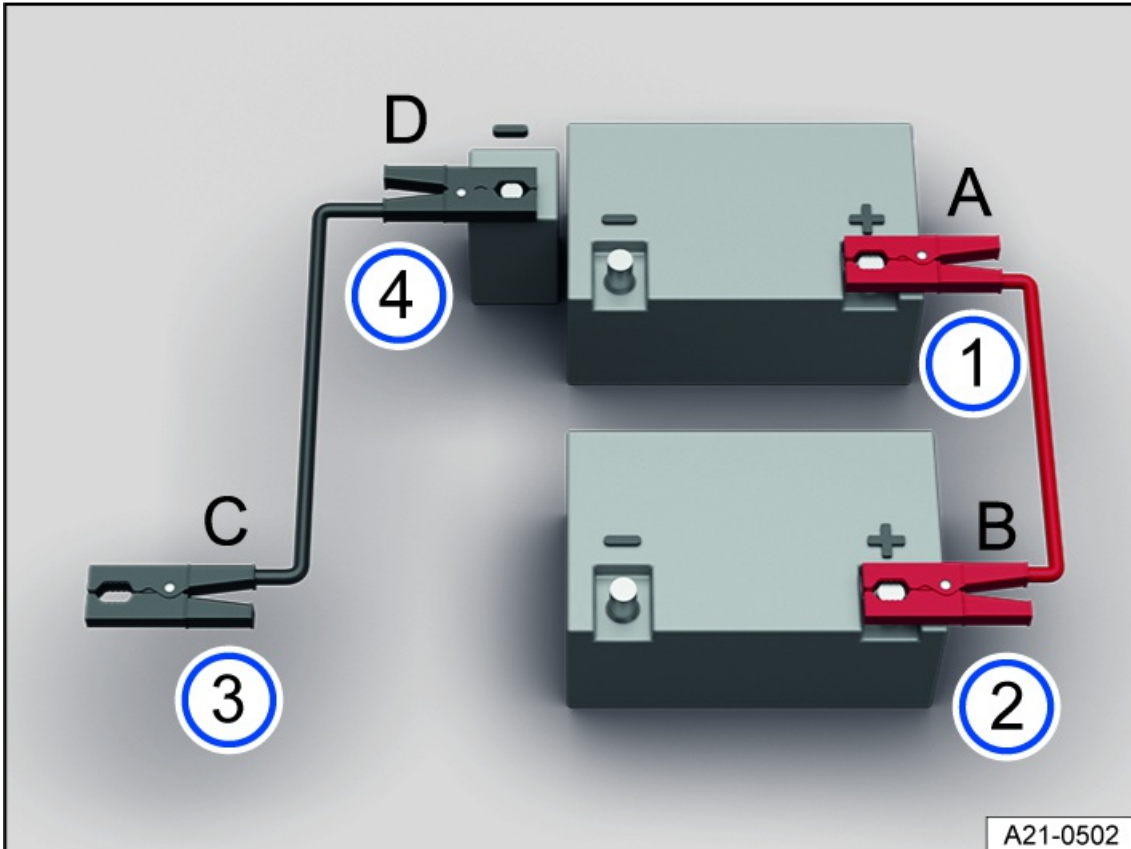

Fig. 159 Diagram for connecting the jumper cables.

- ① Positive battery terminal of the vehicle receiving the jump-start.
- ② Positive battery terminal of the vehicle providing the jump-start.
- ③ Suitable negative terminal of the vehicle providing the jump-start: Preferably a jump-start point (negative connection), a large metal part that is bolted securely to the engine block, or the engine block itself.
- ④ Jump-start point (negative terminal) of the vehicle receiving the jump-start.

Only connect the jumper cables in the sequence A – B – C – D *fig. 159*.

1. Switch the ignition off on both vehicles.
2. In the hood space, open the cover on the positive battery terminal + of the 12 V vehicle battery, if fitted.
3. Connect one end of the red jumper cable to the positive battery terminal + of the discharged 12 V vehicle battery *fig. 159* ①.
4. Connect the other end of the red jumper cable to the positive battery terminal (+) on the vehicle providing current *fig. 159* ②.
5. Connect one end of the black jumper cable to a negative terminal jump-start point – on the vehicle providing current *fig. 159* ③.
Or: if no negative terminal jump-start point – is available, connect to a large metal part that is bolted securely to the engine block or connect to the engine block itself *fig. 159* ③.
6. Connect the other end of the black jumper cable to the negative terminal jump-start point – on the vehicle receiving the jump-start *fig. 159* ④.
7. Route the jumper cables so that they cannot become caught in moving parts in the hood space.

Start the engine

📖 Please read the introductory information and heed the Warnings and Notice ⇒ ⚠️ and ⚠️ *Introduction*.

1. Start the engine in the vehicle that is providing current and allow it to idle.
2. Wait a few minutes and then start the vehicle's engine with the discharged 12 V vehicle battery. If the engine does not start, stop the starting process after ten seconds, and try again after approximately one minute.

If the engine still will not start, contact an authorized Volkswagen dealer or authorized Volkswagen Service Facility.

Removing the jumper cables

📖 Please read the introductory information and heed the Warnings and Notice ⇒ ⚠️ and ⚠️ *Introduction*.

1. Before disconnecting the jumper cables, switch off the low beam headlight if necessary.
2. In the vehicle with the drained 12 V vehicle battery, switch on the blower for the air conditioner and the rear window defroster. This will reduce any voltage surges that may occur when disconnected.
3. Once the vehicle has been jump-started, always disconnect the jumper cables in the order D – C – B – A ⇒ *Connecting the Jumper Cable*.
4. Close the cover of the positive terminal (+), if fitted.

After successful jump-starting, have the 12 V vehicle battery checked by an authorized Volkswagen dealer or authorized Volkswagen Service Facility. Volkswagen recommends contacting an authorized Volkswagen dealer or authorized Volkswagen Service Facility.

Transporting the Vehicle Away and Towing

📖 *Introduction*

If a vehicle can no longer be moved under its own power, the vehicle can be transported away with a tow truck or towed with another vehicle.

Make sure that both drivers are familiar with towing a vehicle. This applies especially if no tow bar is used.

Follow all applicable laws when towing.

! NOTICE

Tow-starting can cause severe damage to the vehicle.

- Jump-start the vehicle to start the engine.

! NOTICE

When towing, there is always the risk of the coupling becoming overloaded when driving off-road, and consequently of the vehicles being significantly damaged

- Always make sure the towing force does not exceed the permitted level and there are no shock loading conditions when towing.

Important information about transporting the vehicle away

📖 Please read the introductory information and heed the Warnings and Notice ⇒ [! Introduction](#).
Transporting the vehicle away refers to using a tow truck to transport a vehicle that cannot be driven.

! WARNING

Vehicle components can be badly damaged by incorrectly attached tow chains, tow ropes or tow bars. This increases the risk of accident and could result in serious or fatal injuries.

- Only ever secure the vehicle to be transported away and towed at the points designed for this purpose.
- Never secure the tow chain, tow rope or tow bar to axle or suspension components.
- Contact an authorized Volkswagen dealer or authorized Volkswagen Service Facility and have the vehicle taken away on a tow truck, if necessary.

! NOTICE

Pushing the vehicle by hand may cause damage to the vehicle, such as deformation or detachment of attachments.

- When pushing the vehicle by hand, make sure that you do not apply any pressure to the taillights, large sheet metal surfaces and side or rear spoilers.

Transporting the Vehicle Away with a Tow Truck

📖 Please read the introductory information and heed the Warnings and Notice ⇒ [! Introduction](#).
The vehicle can be towed with all four wheels standing on a tow truck or with a raised front axle.

Note that it may be necessary to tow the vehicle with all four wheels standing on a tow truck → page , *Towing the Vehicle with Another Vehicle*.

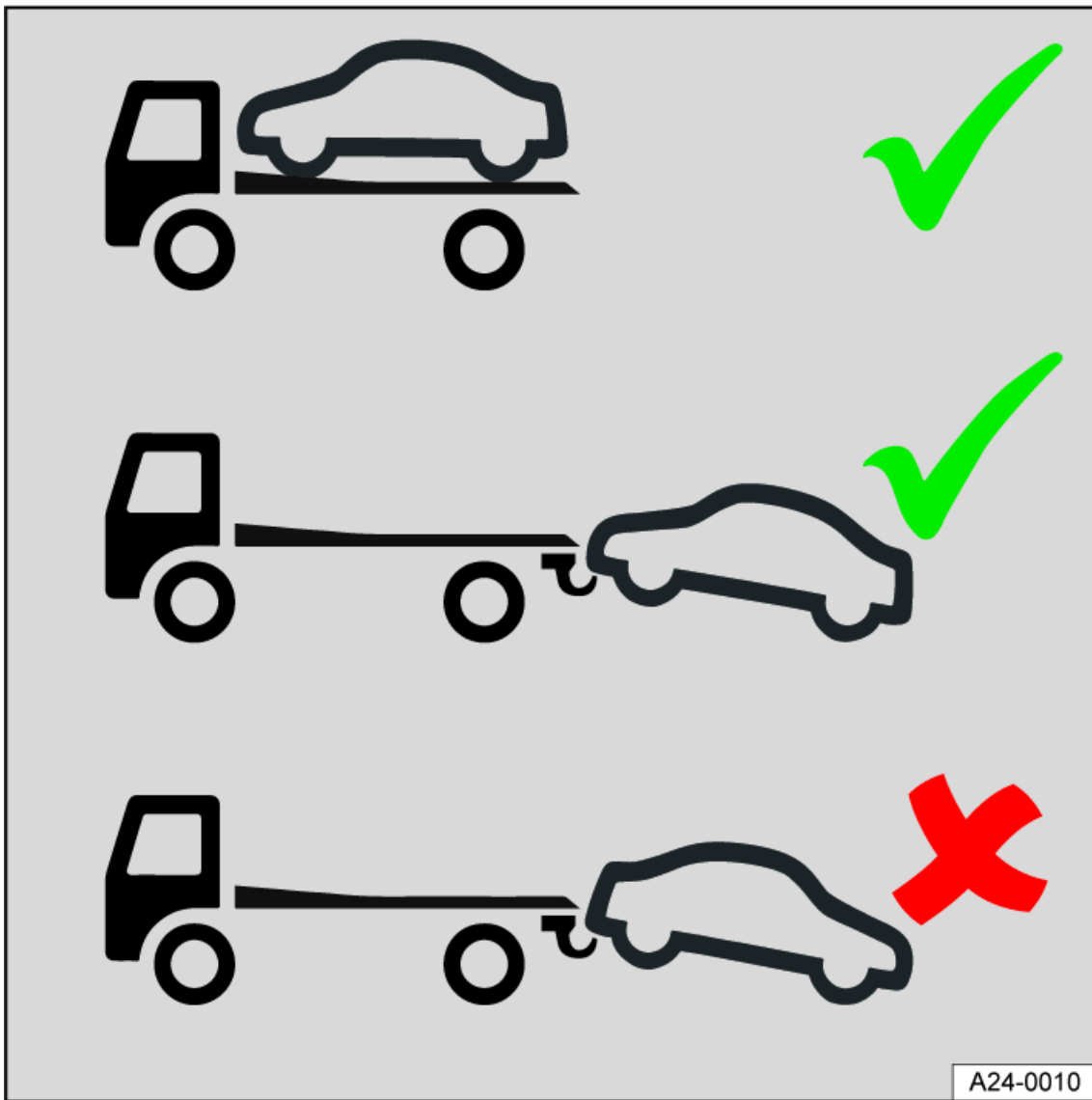

Fig. 160 Transporting the vehicle away with a tow truck.

Information about the attachment points for transporting the vehicle away at the front and rear → page , *Front Attachment Point* , → page , *Rear Attachment Point* .

If the vehicle is transported away with a raised front axle:

- The maximum permissible speed is 50 km/h (approx. 30 mph).
- The maximum permissible distance is 50 km (approx. 30 miles).
- Deactivate the electronic parking brake.
- Make sure the vehicle key is always in the vehicle during the towing process ⇒ *Introduction* .
- Deactivate Automatic Emergency Braking (Front Assist).

NOTICE

If the electronic parking brake switches on during the towing process, wheels may lock. Serious damage to the vehicles may result.

- End the towing process immediately.
- Contact an authorized Volkswagen dealer or authorized Volkswagen Service Facility and have the vehicle taken away on a tow truck, if necessary.

Towing the Vehicle with Another Vehicle

 Please read the introductory information and heed the Warnings and Notice ⇒  *Introduction*.

Towing refers to using a vehicle to pull another vehicle that cannot be driven. The vehicle can be towed using a tow bar or tow rope:

- The maximum permissible speed is 50 km/h (approx. 30 mph).
- The maximum permissible distance is 50 km (approx. 30 miles).

When may your vehicle not be towed by another vehicle?

If one of the following situations applies, in the event of damage, the vehicle must be transported away with all four wheels situated on a tow truck.

- If the 12 V vehicle battery is drained.
- The indicator in the instrument cluster display does not function perfectly.
- The towing distance is greater than 50 km (approx. 30 miles).
- The selector lever of the automatic transmission cannot be moved to neutral (position **N**).
- The electronic parking brake cannot be released.
- The steering lock cannot be released.
- If the wheel clearance or the steering function can no longer be secured after an accident.

The easiest and safest way to tow is using a tow bar. You should use a tow chain or tow rope only if a tow bar is not available. The towing cable should be elastic to protect both vehicles. Use a cable made of synthetic rubber or a similar elastic material.

WARNING

The vehicle handling and braking efficiency will change considerably when it is towed. This may cause you to lose control of the vehicle and result in accidents and serious or fatal injuries.

- Bear in mind that more force is required for steering and braking during towing.

Secure the tow rope or tow bar only at the permitted points:

- Towing lug.
- Ball mount.

WARNING

Vehicle components can be badly damaged by incorrectly attached tow ropes or tow bars. This increases the risk of accident and could result in serious or fatal injuries.

- Only ever secure the vehicle to be recovered and towed at the points designed for this purpose.
- Never secure the tow rope or the tow bar to axle or suspension components.
- Contact an authorized Volkswagen dealer or authorized Volkswagen Service Facility and have the vehicle taken away on a tow truck, if necessary.

Preparations

- Make sure the tow rope is not twisted. Otherwise it could disconnect from the towing eye while towing.
- Switch the ignition and emergency flashers on in both vehicles. However, do not do this if it is prohibited by law.

- Observe the legal regulations and instructions for towing in the Owner's Manual of the other vehicle.

Towing vehicle (front)

1. Only start to drive when the tow rope is taut.
2. Take extra caution when pressing the accelerator pedal.
3. Avoid sudden braking and driving maneuvers.
4. Do not exceed the permitted towing weight of the vehicle.

Vehicle being towed (rear)

A vehicle being towed can still signal a turn using the turn signals even if the emergency flashers are switched on. To do this when the ignition is switched on, activate the turn signal for the desired direction. The emergency flashers will stop while the turn signal is active. The emergency flashers will automatically activate again once the turn signal and high beam lever return to the neutral position.

1. Make sure that the ignition is always switched on so that the steering wheel is not locked and the turn signals and windscreen wipers can be operated if necessary. The brake booster and power steering only work when the engine is running. Otherwise, the brake pedal needs to be pressed much harder and more force is required to steer.
2. Make sure the vehicle key is always in the vehicle during the towing process ⇒  *Introduction*.
3. Deactivate Automatic Emergency Braking (Front Assist).
4. For vehicles with an automatic gearbox: Select gear **N**.
5. Release the electronic parking brake.
6. Make sure the tow rope is always taut.

NOTICE

If the electronic parking brake switches on during the towing process, wheels may lock. Serious damage to the vehicles may result.



- End the towing process immediately.
- Contact an authorized Volkswagen dealer or authorized Volkswagen Service Facility and have the vehicle taken away on a tow truck, if necessary.

NOTICE

If the battery charge level of the 12 V vehicle battery is insufficient, you will not be able to release the electronic parking brake and steering lock. The vehicle may be damaged when towed.

- To release the electronic parking brake and the steering lock, switch the ignition on or start the engine, if necessary by means of a jump-start in the event of a loss of power or malfunctions.
- Contact an authorized Volkswagen dealer or authorized Volkswagen Service Facility and have the vehicle taken away on a tow truck, if necessary.

Front Attachment Point

 Please read the introductory information and heed the Warnings and Notice ⇒  *Introduction*. There are mounting points for a tow truck under the vehicle at the rear left and right.

1. Otherwise, contact an authorized Volkswagen dealer or authorized Volkswagen Service Facility and have the vehicle taken away by a tow truck if necessary.

Front mounting points for a tow truck

In order to be able to pull your vehicle onto a tow truck, attachment points for a tow truck are located behind the front wheels on the left- and right-hand sides.



Fig. 161 Behind the front wheels on the left and right: attachment points for a tow truck under a cover.

1. Before attaching the vehicle at the front left and right, remove the cover for the attachment points on the left and right.

⚠ NOTICE

If you use the attachment points with a tow chain, the vehicle may be damaged.

- Use the trailer hitch to pull the vehicle onto a tow truck.

Rear Attachment Point

📖 Please read the introductory information and heed the Warnings and Notice ⇒ ⚠ *Introduction*.

Depending on the country and the vehicle equipment, the vehicle may have a trailer hitch, a mounting for a towing eye in the bumper, or attachment points for a tow truck under the vehicle.

Vehicles with a trailer hitch

The trailer hitch can be used for towing.

1. Install the ball mount and use it for towing.

⚠ NOTICE

Using an unsuitable towing bar could damage the ball hitch and the vehicle.

- Always use a tow bar specifically designed for mounting on a ball mount for towing.
- If you do not have a suitable tow bar, use a tow rope for towing.

Vehicles without a trailer hitch

1. Please note important information about transporting the vehicle away ⇒ *Important information about transporting the vehicle away.*
2. Before having it towed, check that your vehicle has a threaded mount for a towing eye or rear attachment points for a tow truck.
3. Otherwise, contact an authorized Volkswagen dealer or authorized Volkswagen Service Facility and have the vehicle taken away by a tow truck if necessary.

Installing the rear towing eye

The towing eye must always be kept in the vehicle.

! NOTICE

Using a towing eye that is not suitable for the vehicle can damage the vehicle.

- Always use the towing eye from the supplied vehicle tool kit or another suitable towing eye for towing.



Fig. 162 In the right rear bumper: Remove the cover, variant 1.



Fig. 163 In the right rear bumper: Remove the cover, variant 2.



Fig. 164 In the right rear bumper: Screw in towing eye, variant 1.

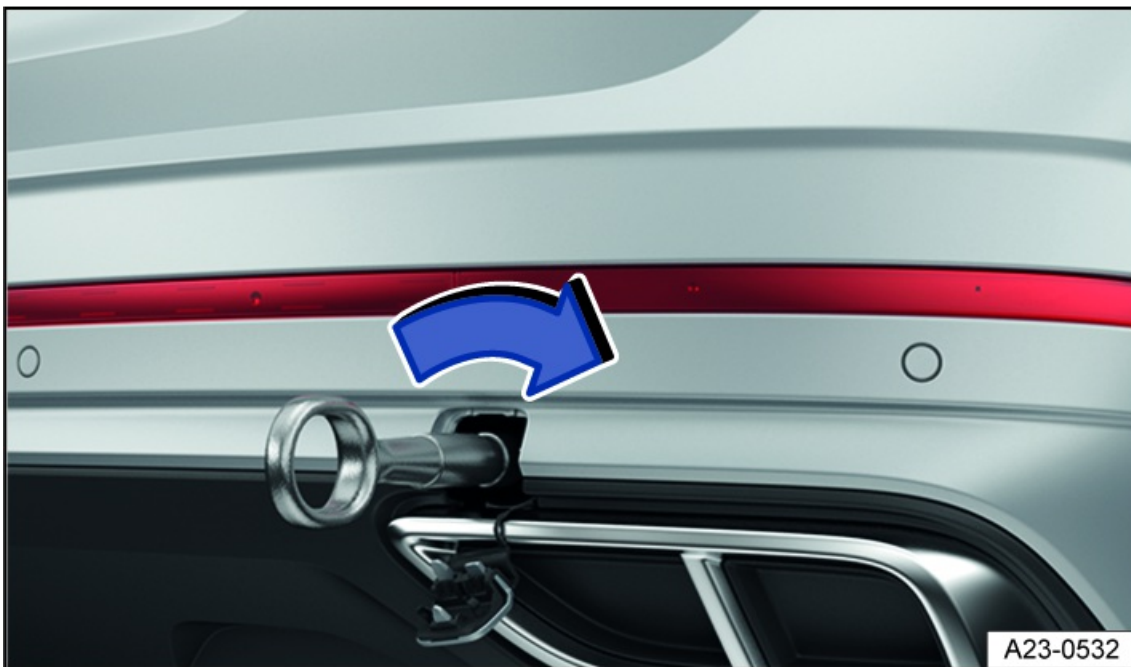

Fig. 165 In the right rear bumper: Screw in towing eye, variant 2.

In vehicles with a trailer hitch, there is no mount for the threaded towing eye behind the cover.

1. Remove the towing eye from the vehicle tool kit in the luggage compartment.
2. Press on the marked area of the cover in the direction of the arrow to release the catch on the cover *fig. 162*.
3. Remove the cover, let it hang from the vehicle or place it in the vehicle if necessary *fig. 162*.
4. Rotate the towing eye in the direction of the arrow as far as possible to install it in the mount *fig. 164*, ⇒ ⚠. Use a suitable object to tighten the towing eye completely and securely in the mount.
5. After the vehicle has been towed, unscrew the towing eye with a suitable object in the opposite direction to the arrow.
6. Insert the cap into the respective opening and press in until it engages.
7. If necessary, clean the towing eye and return it to the vehicle tool kit in the luggage compartment.

⚠ WARNING

If the towing eye is not fully and tightly screwed into the mount, it may tear out of the mount. This may result in accidents and serious injuries during the towing process.

- Before towing, check that the towing eye is fully screwed in.

ⓘ NOTICE

Removing and fitting the cover and towing eye incorrectly may cause damage to the vehicle's paint and body.

- Always remove and fit the cover and towing eye carefully.

Rear mounting points for a tow truck

In order to be able to pull your vehicle onto a tow truck, attachment points for a tow truck are located under the vehicle on the rear left- and right-hand sides.



Fig. 166 Behind the front wheels on the left and right: attachment points for a tow truck.

NOTICE

If you use the rear mounting points with a tow chain, the vehicle will be damaged.

- Use the trailer hitch to pull the vehicle onto a tow truck.

Checking and filling

In the hood space

Safety precautions for working in the hood space

The hood space of a vehicle is a dangerous area. Only perform work in the hood space if you are familiar with the necessary activities and the general safety precautions, and if the correct operating equipment, fluids and suitable tools are available. Work performed incorrectly can result in serious injuries ⇒ . Have all work performed by suitably qualified professionals if necessary. Volkswagen recommends contacting an authorized Volkswagen dealer or authorized Volkswagen Service Facility.

WARNING

The hood space is a dangerous area. Any work in the hood space could lead to accidents and serious or fatal injuries.

- Always work as cautiously and carefully as possible.
- Do not perform work in the hood space unless you are familiar with the required activities.
- If you are not sure how to do the work in the hood space, have the work required carried out by suitably qualified professionals. Volkswagen recommends contacting an authorized Volkswagen dealer or authorized Volkswagen Service Facility.
- Set the electronic parking brake before working in the hood space.
- Move the selector lever to the **P** selector lever position.
- Switch off the ignition and store the remote control vehicle key securely and far enough away from the vehicle to ensure that the engine cannot be started accidentally.
- Never touch hot components in the engine.
- Do not leave any items, such as cleaning cloths or tools, in the hood space.
- Always keep children away from the hood space and never leave them unattended.

WARNING

The hood space contains moving components. When working in the hood space, particularly when starting the vehicle or if the engine is running, contact with moving parts, e.g. fan blades in the radiator fan, may cause serious or fatal injuries.

- Never reach into the radiator fan or into the area near the radiator fan, even if the engine is switched off or the ignition is switched off. The ventilator is temperature-controlled and may switch on by itself.
- Always remove any jewelry and/or ties, tie back long hair, and avoid wearing loose-fitting clothing when performing work.
- Always press the accelerator pedal extremely carefully and never press it without paying close attention. The vehicle could begin moving, even if the electronic parking brake is set.

WARNING

Escaping hot steam or hot coolant and hot components may cause serious burns.

- Never open or close the hood if steam or coolant are escaping.
- Always wait until you can no longer see or hear steam or coolant escaping from the hood space.

WARNING

The cooling system is under pressure when the engine is hot. If the cover is opened carelessly, coolant may spray out and cause serious burns or fatal injuries.

- Never open the cap of the coolant expansion tank when the engine is hot.
- Always protect your face, hands and arms from hot coolant or steam with a large, thick cloth if you have to open the cap of the coolant expansion tank.
- Slowly and very carefully turn the cap of the coolant expansion tank counterclockwise while pressing down lightly on the cap.

WARNING

Additional insulation, such as blankets in the hood space or discarded items such as cleaning cloths or tools, can cause malfunctions, damage to the engine, or fires. This could result in serious or fatal injuries.

- Never cover the engine with blankets or other insulating materials.
- Never leave items in the hood space.

Always park the vehicle safely on a horizontal and firm surface before carrying out any work in the hood space ,
⇒ *Parking*.

WARNING

If the vehicle is not secured against rolling away during maintenance procedures, the vehicle may move unintentionally. This could result in accidents and serious or fatal injuries.

- Manually deactivate the start-stop system.
- Never carry out any work underneath the vehicle unless it is adequately secured to prevent it from rolling.
- Ensure that the vehicle is situated on a horizontal and firm surface and that the wheels are blocked to prevent them from moving when carrying out work underneath the vehicle with its wheels touching the ground.
- If you are working underneath the vehicle, additionally support the vehicle securely with suitable stands. The vehicle jack is not sufficient for this purpose and may collapse.

WARNING

The high voltage in the electrical system may cause electric shocks and burns. This could result in serious or fatal injuries.

- Never short-circuit the electrical system. The 12 V vehicle battery could explode.

Preparing the vehicle for work in the hood space

Always perform the following activities in the specified sequence before all work in the hood space:

1. Safely park the vehicle on a horizontal and firm surface ⇒ *Parking*.
2. Secure the vehicle against rolling away.
3. Remove the remote control vehicle key from the vehicle and store it outside of the vehicle, so that the vehicle does not start accidentally.

4. Let the engine cool down sufficiently.
5. Always keep other people away from the hood space.

Opening and closing the hood



Fig. 167 In the driver's side footwell: Release lever for the hood (general example).

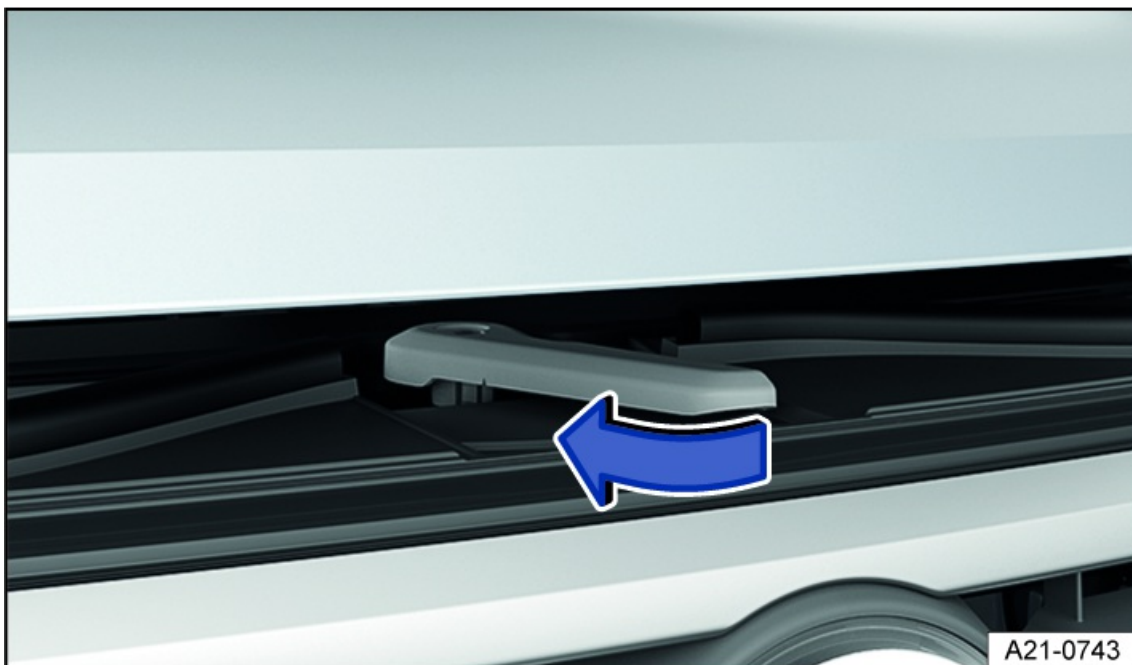



Fig. 168 Above the radiator grille: Opening lever for the hood.

Opening the hood

1. Open the driver door and pull the release lever in the direction of the arrow *fig. 167*.

The hood will pop open from the locking mechanism in the lock carrier ⇒ .

2. To open the hood fully, slightly lift the hood while pushing the actuating lever in the direction of the arrow *fig. 168*.

In the fully open position, the hood is held by the gas-pressure strut.

Closing the hood

1. Push the hood down until you override the force of the gas-pressure strut ⇒ .
2. Allow the hood to fall out a distance of approx. 20 cm (approx. 8 inches) into the catch of the lock carrier, without pressing down on it.

When the hood is closed correctly, it will be flush with the surrounding sections of the vehicle body ⇒ .

WARNING

If the hood is not closed correctly, it could open suddenly while driving and block the view through the windshield. Accidents and serious or fatal injuries could result.

- After closing the hood, check that the catch is engaged correctly in the lock carrier.
- If you realize when driving that the hood is not closed properly, park the vehicle safely and close the hood.

WARNING

Failing to take care when opening and closing the hood can result in serious injuries.

- Do not open or close the hood if any persons are in the closing range of the hood.

NOTICE

Opening and closing the hood incorrectly can cause damage to the hood or wiper arms.

- Only open the hood when wiper mode is switched off and with the windshield wipers folded in.
- Always fold the wiper arms against the windshield before driving.

Indicator for opened engine hood

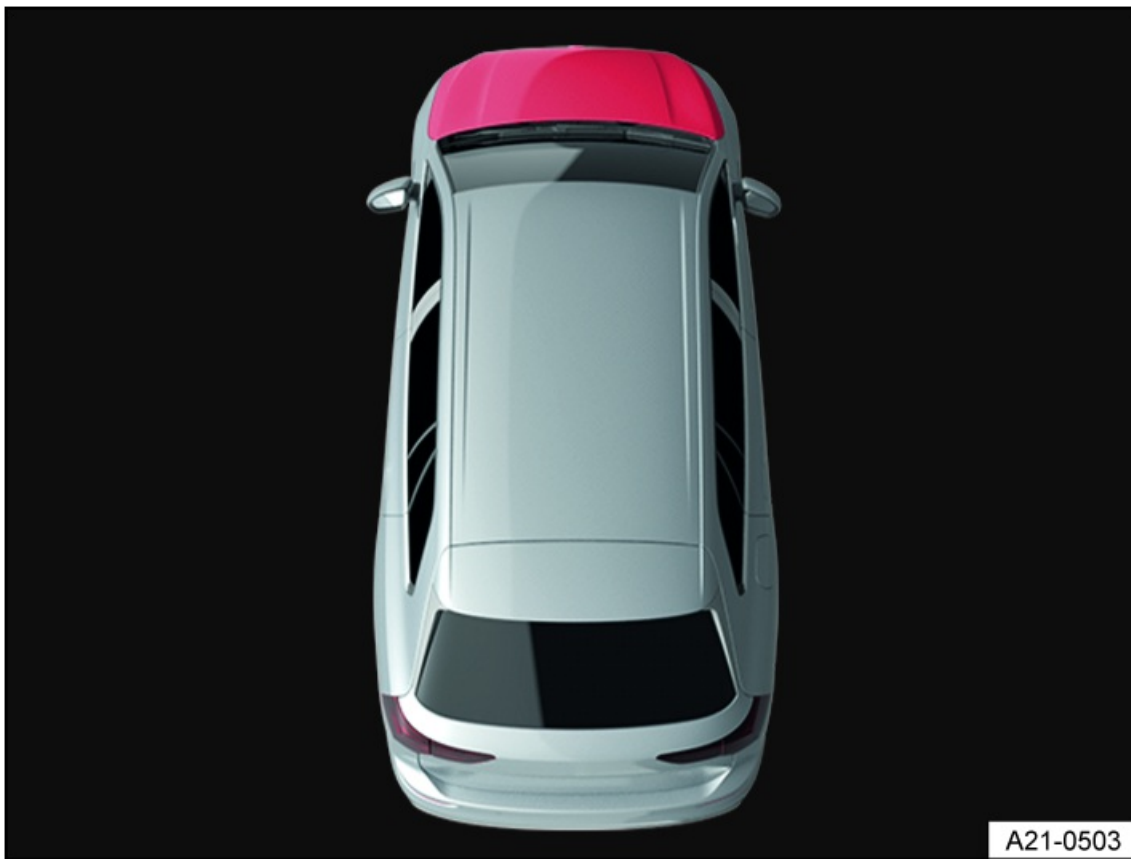

Fig. 169 In the instrument cluster display: the hood is open or not closed correctly (general example).

An image in the instrument cluster display indicates if the hood is open or has not closed correctly ⇒ .

 **Do not continue driving!**

1. Stop the vehicle as soon as it is safe to do so.
2. If necessary, lift the hood and close it again.

The image is also displayed when the ignition is switched off and it disappears several seconds after the doors are closed and the vehicle is locked.

 **WARNING**

Disregarding warning notifications could lead to breakdowns while driving, accidents and serious or fatal injuries.

- Never ignore warning notifications.
- Stop the vehicle as soon as it is safe to do so.
- Do not continue driving and seek professional assistance if the warning light does not go out.

Operating fluids and operating equipment

All operating fluids and operating equipment, such as coolant, engine oil and vehicle batteries, are continuously being developed.

1. Have fluids and operating equipment replaced by suitably qualified professionals. Volkswagen recommends contacting an authorized Volkswagen dealer or authorized Volkswagen Service Facility.

 **WARNING**

Carrying out work on the fuel system may cause fires and serious or fatal injuries due to electrical discharge and flying sparks.

- Always disconnect the 12 V vehicle battery.
- Always have a fully-functioning, checked fire extinguisher nearby.
- Make sure that the vehicle is unlocked when the 12 V vehicle battery is disconnected. Otherwise, the anti-theft alarm system will be activated.

WARNING

Fluids may be poisonous. Improper use and storage may cause serious or fatal injuries.

- Only store fluids in their sealed original containers.
- Never use empty food cans, bottles, or other containers to store fluids, because someone could drink the fluids by mistake.
- Keep children away from all fluids and operating equipment.
- Always read and heed the information and warnings on the packaging for the fluids.
- When using products that emit harmful vapors, always work outdoors or in a well-ventilated area.

WARNING

Fluids and some materials in the hood space are highly flammable and may ignite on contact with hot surfaces, sparks, or naked flames. This can lead to a fire and cause accidents and serious or fatal injuries.

- Never smoke near the hood space.
- Never work near open flames or sparks.
- Never perform work near sources of heat, boilers, or other open flames.
- Never pour or spill fluids on the engine.
- Always have a fully-functioning, checked fire extinguisher nearby.

NOTICE

The use of fluids that do not correspond to the specification can cause serious malfunctions and damage to the engine.

- When topping up or changing fluids, make sure that the fluids correspond to the respective specification.
- Only fill fluids into the designated filler openings.

 Fluids leaking from the vehicle can cause environmental damage.

- Regularly check the ground beneath the vehicle.
- If you see spots of fluid on the ground under the vehicle, have the vehicle checked by an authorized Volkswagen dealer or authorized Volkswagen Service Facility. Volkswagen recommends contacting an authorized Volkswagen dealer or authorized Volkswagen Service Facility.
- Dispose of leaking fluids according to legal and environmental regulations.

Washer fluid

General information

The windshield washer fluid reservoir is located in the hood space.



Fig. 170 In the hood space: Cap on the washer fluid reservoir (general example).



The washer fluid reservoir is identified with the  symbol on the cap *fig. 170*.

1. Check the washer fluid level regularly and fill if necessary.

Preparations

1. Prepare the vehicle for work in the hood space → page , *In the hood space*.
2. Open the hood.

Checking and refilling

1. Check if there is enough washer fluid in the reservoir.
2. To top it up, mix clean water with a suitable alcohol-based windshield cleaner. Follow the mixing instructions on the packaging of the windshield cleaner ⇒ , ⇒ .
3. When the outside temperatures are cold, an anti-freeze agent should be added to the water so that it does not freeze. Follow the mixing instructions on the packaging of the anti-freeze agent.

There is a screen in the filler tube in the windshield washer fluid reservoir. The screen keeps large particles of contaminants from entering the washer nozzles when you refill the washer fluid ⇒ .

Depending on the vehicle equipment and the vehicle, the washer fluid reservoir filling quantity is approximately 3.0 to 6.0 l (approximately 3.1 to 6.3 qt).

 Do not use distilled water to fill the windshield washer fluid tank. This is the only way that the windscreen wiper washer fluid level can be monitored.

WARNING

Unsuitable additives in the windshield washer fluid can create an oily film on the vehicle windshield. This may reduce

visibility and increase the risk of accidents and serious or fatal injuries.

- Never add coolant additive or similar unsuitable additives to the windshield washer fluid.

NOTICE

Using a cleaning agent that contains acid may result in damage and cause the spray nozzles to malfunction.

- Never top up the windshield washer fluid tank using a cleaning agent that contains acid, e.g. vinegar-based cleaners.

NOTICE

Mixing different windshield cleaners can cause the components to flocculate and the spray nozzles to clog.

- Only use suitable alcohol-based windshield cleaners.
- Never mix different windshield cleaners together.

NOTICE

When you top up the windshield washer fluid, if you use a damaged screen or do not use a screen at all, dirt particles may get into the windshield washer fluid tank. The spray nozzles may become clogged.

- Take the screen out only to clean it.
- Replace a damaged or missing screen.

Engine oil

Introduction

The engine oils are determined based on the requirements of the engines, emissions control systems, and the fuel quality. Or all combustion engines, the engine oil comes into contact with combustion residue and fuel, which affects the aging of the engine oil. Using the correct engine oil is essential for the function and service life of the engine. The vehicle is filled at the factory with a special multi-purpose, low-viscosity oil that can generally be used year-round.

The vehicle can consume engine oil. The engine oil consumption can vary and can change throughout the service life of the vehicle. Depending on the driving style and the usage conditions, the engine oil consumption can be up to 1 l (1 qt) per 2000 kilometers (approximately 1200 miles); it can also be higher within the first 5000 kilometers (approximately 3100 miles) on new vehicles. Because of this, the engine oil level must be checked regularly and it is best to check the level before long drives.

WARNING

Engine oil gets extremely hot when the engine is running. Failure to take care when handling hot engine oil can cause serious bodily burns. This could result in serious or fatal injuries.

- Always allow the engine to cool down before starting work with the engine oil.

WARNING



Engine oil is poisonous. Contact with engine oil, especially swallowing engine oil, may result in serious or fatal injuries.

- If you swallow engine oil, seek urgent medical help.
- If you have health problems after working with engine oil, seek medical help.
- Always store engine oil in the sealed original container and keep it out of the reach of children. This also applies to used oil until it is disposed.
- Never use empty food cans, bottles, or other containers to store engine oil, because someone could drink the engine oil by mistake.
- Avoid regular contact with engine oil to prevent damage to your skin.
- Protect your skin, face and particularly your eyes when working with engine oil.
- Do not eat, drink or smoke when working with engine oil.
- Wash your skin with soap and water after working with engine oil.

 Engine oil that has dripped and spilled can pollute the environment.

- Collect any leaking fluids and dispose of them according to legal and environmental regulations.

Engine oil standards

 Please read the introductory information and heed the Warnings and Notice ⇒  *Safety precautions for working in the hood space.*

Engine oil label

There is a label on the lock carrier at the front of the hood space that shows which engine oil should be added *fig. 171.*

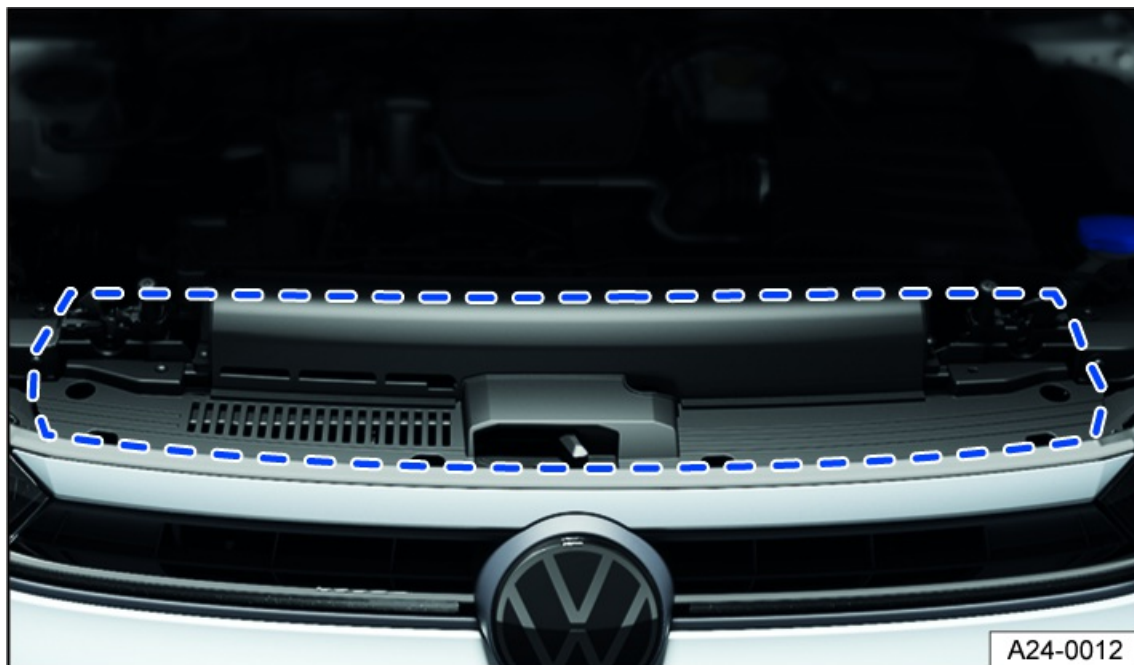

Fig. 171 Area for the engine oil label (general example).

If you need to top up the engine oil, use an oil with the prescribed engine oil standard and engine oil viscosity *fig. 172.*

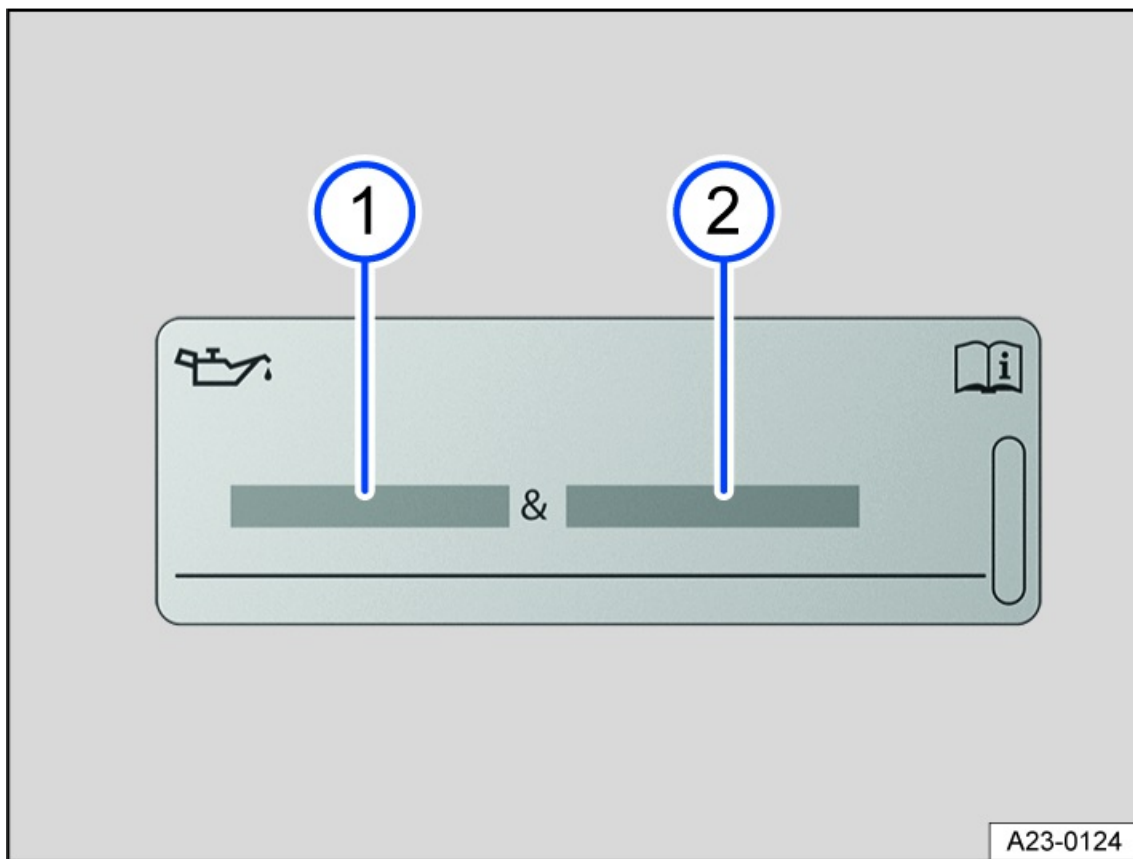

Fig. 172 Engine oil standard and engine oil viscosity label (general example).

- ① Engine oil viscosity information.
- ② Engine oil standard information.

If the prescribed engine oil is used *fig. 172*, the engine oil level can be corrected any number of times as needed ⇒ *Checki the engine oil level and adding oil.*

If no engine oil that meets the prescribed standard is available, you may, in an emergency, top up the engine oil no more than once before your next standard oil change using no more than 0.5 l (0.5 qt) of engine oil that meets the following deviating standards:

- Gasoline engines: VW standard 504 00 and ACEA C3, ACEA C4, API SP or ILSAC GF-6A. All viscosity classes in these standards are permitted.

Having the oil change carried out by an authorized Volkswagen dealer or authorized Volkswagen Service Facility is recommended. Volkswagen recommends contacting an authorized Volkswagen dealer or authorized Volkswagen Service Facility.



ⓘ NOTICE

Using engine oils that have not been approved in accordance with the respective VW standard can cause damage to the engine.

- When refilling, only use engine oils that comply with the quality requirements of the respectively applicable VW standard.
- Only if you absolutely must, add max. 0.5 l (0.5 qt) of engine oil that does not comply with the specified engine oil standards.

 Volkswagen recommends Volkswagen Genuine oil.

Changing the engine oil

 Please read the introductory information and heed the Warnings and Notice ⇒  *Safety precautions for working in the hood space.*

The engine oil must be changed regularly and in line with the service intervals ⇒ *Information About Service.*

Additives in the engine oil can make new engine oil appear dark after a brief engine run time. This is normal and is no reason to change the engine oil more frequently.

WARNING

If care is not taken when changing engine oil, the oil can cause environmental damage, serious burns, or fire. This could result in serious or fatal injuries.

- Always allow the engine to cool down completely before the engine oil change.
- Always wear eye protection for the engine oil change.
- Keep your arms horizontal when using your fingers to unscrew the oil drain plug, so that the draining oil does not drip down your arm.
- Use a container suitable for collecting used oil that can hold at least the entire quantity of oil in the engine.

NOTICE

Changing the engine oil and filter requires special tools and specialist knowledge. Failing to act properly may cause damage to the vehicle.

- For this reason, always have the engine oil and filters changed by an authorized Volkswagen dealer or authorized Volkswagen Service Facility. Volkswagen recommends contacting an authorized Volkswagen dealer or authorized Volkswagen Service Facility.

 Engine oil can pollute the environment. Dispose of the engine oil according to legal and environmental regulations and only at a collection point for used oil, e.g. a recycling center or specialist retailer.

Checking the engine oil level and adding oil

 Please read the introductory information and heed the Warnings and Notice ⇒  *Safety precautions for working in the hood space.*

Preparations



Fig. 173 In the hood space: engine oil filler cap (general example).

To avoid an incorrect oil level reading, observe the following steps:

1. With the engine warm from operation, safely park the vehicle on a horizontal and firm surface ⇒ *Parking*.
2. Wait at least five minutes for the engine oil to flow back into the oil pan.
3. Open the hood.
4. Identify the engine oil filler opening.

The engine oil filler opening is identified by the  *fig. 173* symbol on the cap.

Checking the engine oil level

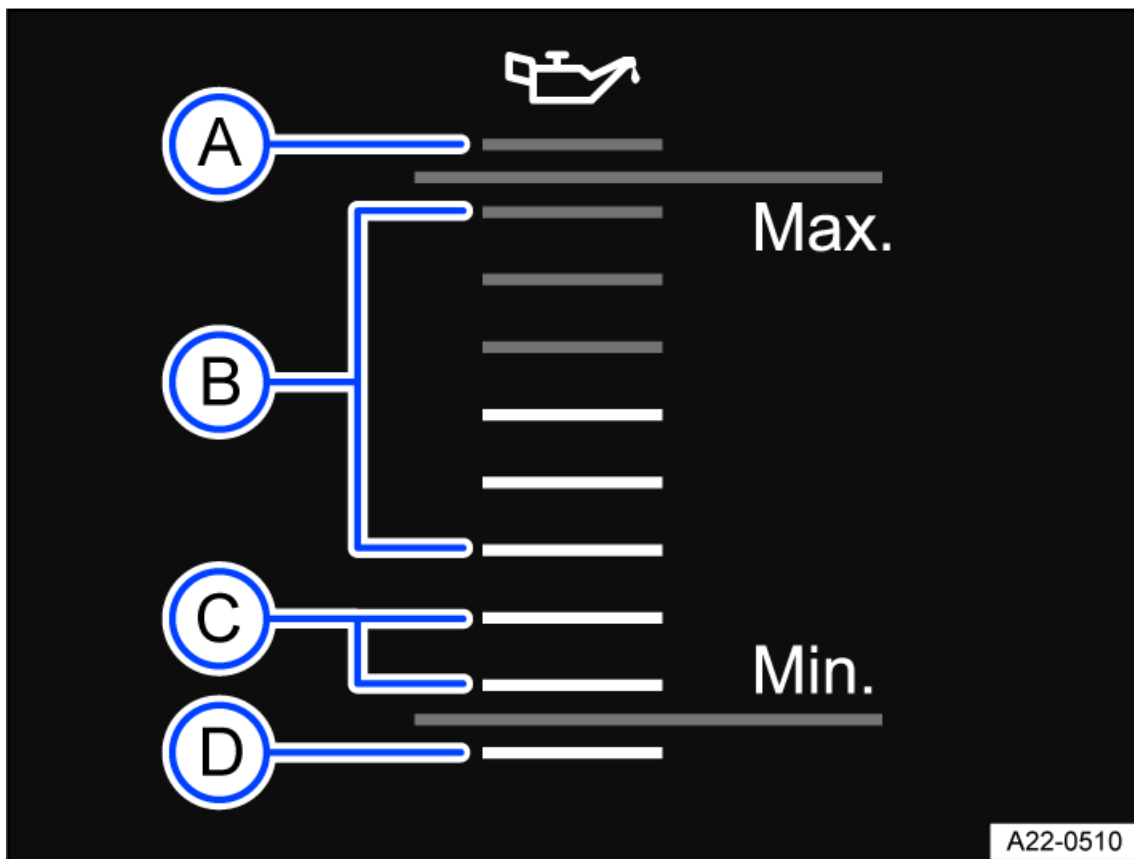







Fig. 174 In the Infotainment system: oil level display (general example).

- Ⓐ Do not add engine oil.
- Ⓑ Oil level in the normal range.
- Ⓒ Engine oil level low – you should add oil.
- Ⓓ Engine oil level low – you must add oil.

To check the engine oil level on the Infotainment system, perform the following steps:

1. Switch the ignition on.
2. Tap the  function key.
3. Tap the  Vehicle function key.
4. Tap the  Status function key.
5. Tap the  Oil function key.

Possible measures after reading the engine oil level in the Infotainment system:

- Ⓐ Do not add any engine oil, do not restart the engine and contact an authorized Volkswagen dealer or authorized Volkswagen Service Facility.
- Ⓑ Oil level in the normal range.
- Ⓒ Engine oil level low. You should add engine oil ⇒ .
- Ⓓ Engine oil level below minimum. You must add engine oil.

If the engine oil level is in the lower section Ⓑ or in section Ⓒ, you can add engine oil up to the middle of section Ⓑ, e.g. there is heavy engine load.

Adding engine oil





WARNING

When topping up, engine oil can spill out or overflow and can ignite if it comes into contact with engine parts that are hot or can become hot. This may cause burns or a fire. This could result in serious or fatal injuries.

- Always make sure that the engine oil cap is installed securely on the engine filler opening after adding oil and that the oil dipstick is inserted correctly in the guide tube.
- Always use a suitable filling aid when topping up the engine oil.

Only perform these activities in the specified order ⇒ :

1. Remove the cap on the engine oil filler *fig. 173*.
2. Top up the engine oil gradually in small quantities, not more than 0.5 l (0.5 qt) in total, or follow the recommendation in the display of the Volkswagen Digital Cockpit. Volkswagen recommends using the approved engine oils in accordance with the respective VW standard.
3. To avoid overfilling, you must wait at least one minute each time you add engine oil so that the engine oil can flow into the oil pan.
4. Read the oil level on the digital oil level display again before adding a little more. When you are done adding oil, the oil level should be in the center of area *fig. 174* .
5. If you accidentally add too much engine oil and the engine oil level is in the area above *fig. 174* , do not start the engine ⇒ . Contact an authorized Volkswagen dealer or authorized Volkswagen Service Facility for assistance.
6. Close the cap on the engine oil filler when you are done adding engine oil *fig. 173*.
7. Close the hood.

NOTICE

Starting the engine with the engine oil level too high after refilling can cause engine damage.

- Do not start the engine, and seek professional assistance.

NOTICE

Using incorrect fluids can result in malfunctions and engine damage.

- When topping up fluids, make sure the correct fluids are added to the correct reservoirs.

 Volkswagen recommends using the approved engine oils in accordance with the respective VW standard.

 If it is not clear where the cap is, contact an authorized Volkswagen dealer or authorized Volkswagen Service Facility. Volkswagen recommends contacting an authorized Volkswagen dealer or authorized Volkswagen Service Facility.

Troubleshooting

 Please read the introductory information and heed the Warnings and Notice ⇒  *Safety precautions for working in the hood space.*

 Engine oil pressure too low

The red warning light blinks. A message is shown in the instrument cluster display.

 **Do not continue driving!** Engine damage could result.

1. Stop the vehicle as soon as it is safe to do so ⇒ *Parking*.

2. Stop the engine.
3. Check the engine oil level ⇒ *Checking the engine oil level and adding oil*.
4. If the warning light flashes, do not continue driving or let the engine run, even if the oil is at the correct level. Engine damage could result. Contact an authorized Volkswagen dealer or authorized Volkswagen Service Facility for assistance.

Engine oil level very low

The red warning light blinks. A message is shown in the instrument cluster display.

 **Do not continue driving!** Engine damage could result.

1. Stop the vehicle as soon as it is safe to do so ⇒ *Parking*.
2. Stop the engine.
3. Check the engine oil level ⇒ *Checking the engine oil level and adding oil*.
4. If necessary, top up the engine oil gradually in small quantities (not more than 0.5 l (0.5 qt) in total) or observe the top-up recommendation in the display of the Volkswagen Digital Cockpit.
5. If the warning light lights up, do not continue driving or let the engine run, even if the oil is at the correct level. Engine damage could result. Contact an authorized Volkswagen dealer or authorized Volkswagen Service Facility for assistance.

Engine oil level too low

The yellow indicator light turns on. A message is shown in the instrument cluster display.

1. Stop the vehicle as soon as it is safe to do so ⇒ *Parking*.
2. Stop the engine.
3. Check the engine oil level ⇒ *Checking the engine oil level and adding oil*.
4. If necessary, top up the engine oil gradually in small quantities (not more than 0.5 l (0.5 qt) in total) or observe the top-up recommendation in the display of the Volkswagen Digital Cockpit.
5. If the indicator light comes on, do not continue driving or let the engine run, even if the oil is at the correct level. Engine damage could result. Contact an authorized Volkswagen dealer or authorized Volkswagen Service Facility for assistance.

Engine oil level too high

The yellow indicator light turns on. A message is shown in the instrument cluster display.

1. Stop the vehicle as soon as it is safe to do so ⇒ *Parking*.
2. Stop the engine.
3. Check the engine oil level ⇒ *Checking the engine oil level and adding oil*.
4. If the engine oil level is too high, do not drive any further or leave the engine running. Engine damage could result. Contact an authorized Volkswagen dealer or authorized Volkswagen Service Facility for assistance.

or Engine oil system malfunction

The indicator light flashes yellow. A message is shown in the instrument cluster display.

1. Contact a suitably qualified professional. Volkswagen recommends contacting an authorized Volkswagen dealer or authorized Volkswagen Service Facility.

Coolant

Introduction

Only perform work on the cooling system if you are familiar with the necessary activities and the general safety precautions, and if the correct operating equipment, fluids and suitable tools are available. Work performed incorrectly can result in serious injuries ⇒ . Have all work performed by suitably qualified professionals if necessary. Volkswagen recommends contacting an authorized Volkswagen dealer or authorized Volkswagen Service Facility.

WARNING

Coolant is toxic. Contact with coolant, especially swallowing coolant, may result in serious or fatal injuries.

- If you swallow coolant, seek urgent medical help.
- If you have health problems after working with coolant, seek medical help.
- Always store coolant in the sealed original container and keep it out of the reach of children.
- Never use empty food cans, bottles, or other containers to store coolant, because someone could drink the coolant by mistake.
- Avoid regular contact with coolant to prevent damage to your skin.
- Protect your skin, face and particularly your eyes when working with coolant.
- Do not eat, drink or smoke when working with coolant.
- Wash your skin with soap and water after working with coolant.

WARNING

In extremely low temperatures, the coolant can freeze and the vehicle could break down. This can cause the heating to stop working in the vehicle. Vehicle occupants could die of exposure if they do not have sufficient warm clothing.

- Make sure that the quantity of coolant additive is adjusted to the lowest expected ambient temperature in which the vehicle is operating.
- Only use coolant additive approved by the manufacturer.

 Coolant and coolant additives can pollute the environment.

- Collect any leaking fluids and dispose of them according to legal and environmental regulations.

Coolant specification

 Please read the introductory information and heed the Warnings and Notice ⇒  *Safety precautions for working in the hood space.*

The cooling system is filled at the factory with a mixture of specially prepared water and at least 40% coolant additive G12evc (TL 744-L).

The proportion of coolant additive must always be at least 40% to protect the cooling system. If greater freeze protection is needed due to the climate, the proportion of coolant additive can be increased. However, the proportion of coolant additive must not exceed 55%, because otherwise the freeze protection will be reduced and the cooling effect will be decreased.

The coolant additive can be recognized by its violet color. The mixture of water and coolant additive provides freeze protection down to approx. -25 °C (approx. -13 °F), protects the light-alloy parts in the cooling system against corrosion, prevents calcium deposits and significantly increases the boiling point of the coolant.

If the coolant is being topped up, a blend of distilled water and at least 40% of the G12evo coolant additive must be used to ensure optimum corrosion protection ⇒ .

! NOTICE

The coloring of the coolant results from the mixture of the purple coolant additive and distilled water. If the fluid in the coolant expansion tank is not purple, but another color, e.g. brown, the appropriate coolant has been mixed with another coolant that is not suitable. This may result in serious malfunctions or damage to the drive and cooling system.

- Only use coolant additive approved by the manufacturer.
- If the coolant turns brown, have it changed immediately by a suitably qualified professional. Volkswagen recommends contacting an authorized Volkswagen dealer or authorized Volkswagen Service Facility.
- Never mix original Volkswagen coolant additives with coolant additives that are not approved by Volkswagen when topping up.

! NOTICE

The engine coolant must always have a correct mixing ratio. If the mixing ratio is not correct, this may result in serious malfunctions or damage to the drive and cooling system.

- Have the correct mixing ratio checked by a suitably qualified professional, and restore if necessary, i.e. if there is doubt about the mixing ratio. Volkswagen recommends contacting an authorized Volkswagen dealer or authorized Volkswagen Service Facility.

Checking the coolant level and refilling coolant

 Please read the introductory information and heed the Warnings and Notice ⇒  *Safety precautions for working in the hood space.*

Preparations

1. Safely park the vehicle on a horizontal and firm surface ⇒ *Parking*.
2. Allow the engine to cool ⇒ .
3. Open the hood.

The coolant expansion tank can be identified by the red  symbol on the cap *fig. 175*.



Fig. 175 In the hood space: cap of the coolant expansion tank (general example).

⚠ WARNING

Escaping hot steam or hot coolant and hot components may cause serious burns.

- Never open the hood if you can see or hear steam or coolant escaping from the hood space.
- Always wait until you can no longer see or hear steam or coolant escaping from the hood space.

⚠ WARNING

The cooling system is under pressure when the engine is hot. If the cover is opened carelessly, coolant may spray out and cause serious burns or fatal injuries.

- Never open the cap of the coolant expansion tank when the engine is hot.
- Always protect your face, hands, and arms from hot coolant or steam with a large, thick cloth if you have to open the cap of the coolant expansion tank.
- Slowly and very carefully turn the cap of the coolant expansion tank counterclockwise while pressing down lightly on the cap.

Checking the coolant level



Fig. 176 In the hood space: markings on the coolant expansion tank (general example).

When new vehicles are delivered or after repairs to the cooling system, the coolant level may be above the marked area. This is normal. The coolant does not need to be extracted.

The coolant level cannot be checked exactly for every model, because the view of the fluid level in the coolant expansion tank may be obstructed. If you cannot read off the coolant level accurately, contact a suitably qualified professional. Volkswagen recommends contacting an authorized Volkswagen dealer or authorized Volkswagen Service Facility.

1. When it is cold, check the coolant level using the markings on the side of the coolant expansion tank *fig. 176*. The coolant level must be between the markings.
2. If the fluid level in the coolant expansion tank is below the minimum mark (“min”), ensure that the coolant is topped up. When the coolant is warm, the coolant level may be slightly above the upper marking.
3. If coolant is no longer visible in the coolant expansion tank, do not add coolant ⇒ ⚠.

Refilling coolant

1. Carefully unscrew the cap ⇒ ⚠.
2. Only add new coolant that conforms to the Volkswagen specification up to as far as the upper fill level marking. ⇒ *Coolant specification*. After topping up the coolant, the coolant level must be between the markings on the coolant expansion tank *fig. 176*.
3. Install the cap securely.
4. Check the coolant level after one day. If the fill level of the coolant expansion tank drops below the minimum marking (“min”) again, contact an authorized Volkswagen dealer or authorized Volkswagen Service Facility and have the cooling system checked. Volkswagen recommends contacting an authorized Volkswagen dealer or authorized Volkswagen Service Facility.

If there is no coolant available that conforms to the required specification, initially only top up with distilled water. Then have the correct mixture ratio using the specified coolant additive restored as soon as possible by a suitably qualified professional. Volkswagen recommends contacting an authorized Volkswagen dealer or authorized Volkswagen Service Facility ⇒ ⚠.

! NOTICE

Coolant expands when it heats up. If coolant is topped up above the marked level, excess coolant may leak out and cause damage to the vehicle.

- Do not refill the system with coolant above the upper edge of the marked area of the coolant expansion tank.

! NOTICE

If there is no more coolant in the coolant expansion tank, air can get into the cooling system. This could result in damage to the engine.

- Do not continue driving.
- Do not top up the coolant.
- See an authorized Volkswagen dealer or authorized Volkswagen Service Facility for assistance.

! NOTICE

The chemical components contained in water that is not distilled can cause considerable corrosion damage in the engine. This can cause engine malfunctions.

- Only use distilled water for refilling the system!
- If you have added water that is not distilled, have the fluid in the cooling system changed completely by suitably qualified professionals. Volkswagen recommends contacting an authorized Volkswagen dealer or authorized Volkswagen Service Facility.

! NOTICE

The use of incorrect fluids can cause serious malfunctions and damage to the engine.

- When filling or changing fluids, make sure the correct fluids are added to the corresponding reservoirs.

Troubleshooting

 Please read the introductory information and heed the Warnings and Notice ⇒  *Safety precautions for working in the hood space.*

Coolant

The red warning light turns on. The coolant temperature is too high or the coolant level is too low.

 Do not continue driving! Engine damage could result.

1. Stop the vehicle as soon as it is safe to do so ⇒ *Parking.*
2. Stop the engine.
3. Allow the engine to cool.
4. Check the coolant level on the coolant expansion tank ⇒ *Checking the coolant level and refilling coolant.*
5. If the warning light does not turn off, do not continue driving or let the engine run, even if the coolant is at the correct level
6. Contact an authorized Volkswagen dealer or authorized Volkswagen Service Facility for assistance.

Brake fluid

Introduction

Brake fluid absorbs moisture from the air over the course of time. Too much water in the brake fluid causes damage to the brake system. Water lowers the boiling point of the brake fluid. If the water content in the brake fluid is too high, vapor lock may form in the brake system during heavy braking and full braking. Vapor lock reduces the braking efficiency, increases the braking distance considerably, and can lead to a total failure of the brake system. Your own safety and the safety of others on the road depends on your brake system functioning correctly at all times.

WARNING

Brake fluid is poisonous. Contact with brake fluid – in particular, if brake fluid is swallowed – may result in serious injury or death.

- If you swallow brake fluid, seek urgent medical help.
- If you have health problems after working with brake fluid, seek medical help.
- Always store brake fluid out of the reach of children and only within the sealed original container.
- Never use empty food cans, bottles, or other containers to store brake fluid, because someone could drink the brake fluid by mistake.
- Avoid regular contact with brake fluid to prevent damage to your skin.
- Protect your skin, face, and particularly your eyes when working with brake fluid.
- Do not eat, drink, or smoke when working with brake fluid.
- Wash your skin with soap and water after working with brake fluid.

NOTICE



Spilled or leaking brake fluid will damage the vehicle's surfaces. The vehicle's paint, plastic parts, and tires may be damaged.

- Immediately wipe up any spilled or leaking brake fluid that comes into contact with vehicle components.
- Then rinse all vehicle parts with plenty of water.

 Brake fluid can pollute the environment.

- Collect any leaking fluids and dispose of them according to legal and environmental regulations.

Brake fluid specifications

 Please read the introductory information and heed the Warnings and Notice ⇒  *Safety precautions for working in the hood space.*

Volkswagen has developed a special brake fluid that is optimized for the vehicle's brake system. For optimum performance of the brake system, Volkswagen recommends only using brake fluid that complies with the VW standard 501 14.

Before using brake fluid, check that the brake fluid specification on the bottle matches the vehicle requirements.

Brake fluid that complies with the VW standard 501 14 can be obtained from an authorized Volkswagen dealer or authorized Volkswagen Service Facility.

If this type of brake fluid is not available and it is therefore necessary to use a different high-quality brake fluid instead, a brake fluid that meets the requirements of DIN ISO 4925 or the US standard FMVSS 116 DOT 4 CLASS 6 can be used.

Not all brake fluids that comply with the requirements of DIN ISO 4925 or US Standard FMVSS 116 DOT 4 CLASS 6 have the same chemical composition. Some of these brake fluids can contain chemicals that can destroy or damage components of the vehicle brake system over time.

Brake fluid that complies with the VW standard 501 14 meets the requirements of DIN ISO 4925 or the US Standard FMVSS 116 DOT 4 CLASS 6.

Checking the Brake Fluid

📖 Please read the introductory information and heed the Warnings and Notice ⇒ ⚠️ *Safety precautions for working in the hood space.*

Preparations

1. Safely park the vehicle on a horizontal and firm surface ⇒ *Parking.*
2. Open the hood.

Checking the Brake Fluid Level

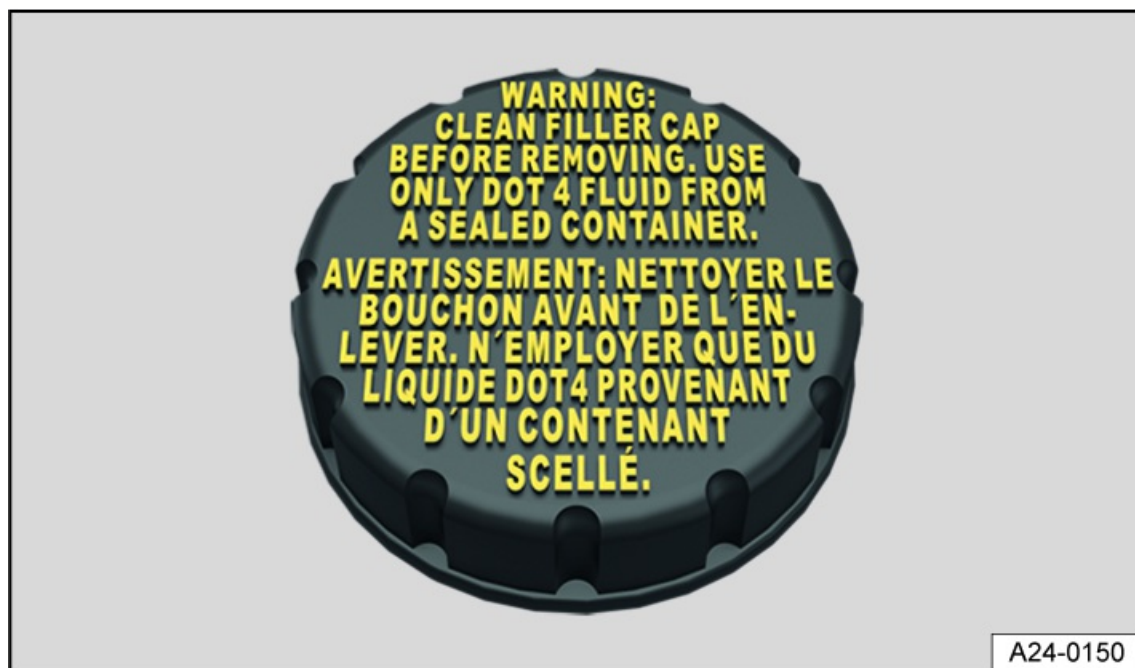

Fig. 177 In the hood space: Cap on the brake fluid reservoir.

The brake fluid reservoir can be recognized by its cap *fig. 177.*

The brake fluid level cannot be checked precisely on all models because the hood or engine components may obstruct the view of the fluid level in the reservoir.

- If you cannot read the brake fluid level clearly, see an authorized Volkswagen dealer or authorized Volkswagen Service Facility for assistance. Volkswagen recommends contacting an authorized Volkswagen dealer or authorized Volkswagen Service Facility.
- If the brake fluid level is not between the min. and max. marking on the brake fluid reservoir, contact an authorized Volkswagen dealer or authorized Volkswagen Service Facility ⇒ ⚠️. Volkswagen recommends contacting an authorized Volkswagen dealer or authorized Volkswagen Service Facility.

The brake fluid level decreases slightly when the vehicle is being used as the brake pads wear and the brakes automatically adjust themselves.

⚠️ WARNING

A low brake fluid level or unsuitable brake fluid may cause the brakes to fail or may reduce braking efficiency. Accidents and serious or fatal injuries could result.

- Have the brake system and brake fluid level checked regularly.
- Be sure to use the correct brake fluid.
- Only use brake fluid that expressly complies with the VW standard 501 14.
- Only use a high-quality brake fluid that complies with DIN ISO 4925 CLASS 6 or the US standard FMVSS 116 DOT 4 in the exceptional case that a brake fluid that conforms to VW standard 501 14 is not available.

Changing brake fluid

An authorized Volkswagen dealer or authorized Volkswagen Service Facility can provide information about the interval for changing the vehicle brake fluid. Volkswagen recommends contacting an authorized Volkswagen dealer or authorized Volkswagen Service Facility.

- Have the brake fluid changed regularly.
- Only have brake fluid added that meets the required specifications.

WARNING

Vapor lock may occur in old brake fluid due to absorbed moisture during hard braking, reducing braking efficiency and potentially causing total brake failure. Accidents and serious or fatal injuries could result.

- Have the brake fluid changed regularly.
- Only have new brake fluid added.

Troubleshooting

 Please read the introductory information and heed the Warnings and Notice ⇒  *Safety precautions for working in the hood space.*

BRAKE Brake fluid level

The red warning light turns on. The brake fluid level is too low.

 Do not continue driving! This could result in the brake failing.

1. Stop the vehicle immediately as soon as it is safe to do so ⇒ *Parking.*
2. Check the brake fluid level.
3. If the brake fluid level is too low, contact an authorized Volkswagen dealer or authorized Volkswagen Service Facility.

12 V vehicle battery

Introduction

The 12-volt vehicle battery is a component of the electrical system and serves to supply energy to the vehicle. During maintenance procedures, the 12 V vehicle battery is checked and replaced if necessary.

You may only perform procedures on the electrical system yourself if you are familiar with the necessary activities and the general safety precautions, and if the correct operating equipment and fluids and suitable tools are available. Work performed incorrectly can result in serious injuries ⇒ .

Information about warning and indicator lights can be found in the troubleshooting section at the end of the chapter ⇒ *Troubleshooting.*

Battery switch-off in an accident with triggering of the airbag

In vehicles with a 12 V vehicle battery in their vehicle interior or luggage compartment, the electrical connection to the 12 V vehicle battery is pyrotechnically disconnected in an accident with airbag deployment. This prevents a short circuit. For more information on the installation location of the vehicle battery, refer to section → page , *Checking the 12 V vehicle battery acid level*.

Detailed warnings for the 12 V vehicle battery

☹ Always wear eye protection. ⚠ Battery acid is highly corrosive. Always wear protective gloves and eye protection. ☹ Fire, sparks, open flame, and smoking are forbidden. ⚠ A highly explosive mixture of gases forms when charging the 12 V vehicle battery. ☹ Always keep children away from battery acid and the 12 V vehicle battery. ☹ Always heed the Owner's Manual.

WARNING

Performing work on the 12 V vehicle battery and the electrical system can cause serious injuries, fires, or electric shocks. This could result in serious injuries.

- Always read and follow the warning information on the 12 V vehicle battery.
- Before performing any work on the 12 V vehicle battery, switch off the ignition and all electrical equipment and disconnect the 12 V battery negative cable.
- Always keep children away from battery electrolyte and the 12 V vehicle battery.
- When handling 12 V vehicle batteries, always protect your hands, arms, and face from spraying battery acid.
- Always wear eye protection and safety gloves.
- Never short circuit the battery terminals.
- Have all work performed by suitably qualified professionals. Volkswagen recommends contacting an authorized Volkswagen dealer or authorized Volkswagen Service Facility.

WARNING

When work is carried out on the 12 V vehicle battery, a highly explosive, flammable gas mixture builds up. Sparks could form and ignite the flammable gas that is released by the 12 V vehicle battery. This can result in serious injury or death.

- Always keep fires, sparks, open flames, and lit cigarettes far away from the 12 V vehicle battery.
- Avoid creating sparks when working with wires and electrical equipment or when discharging static electricity.

WARNING

California Proposition 65 Warning.

- This product can expose you to chemicals including lead and lead components, which are known to the State of California to cause cancer and birth defects or other reproductive harm. For more information go to <https://www.P65Warnings.ca.gov>.

NOTICE

UV rays can damage the battery housing.

- Do not expose the 12 V vehicle battery to direct sunlight for a long period of time.

NOTICE

The 12 V vehicle battery could freeze and be destroyed.

- Protect the 12 V vehicle battery against freezing temperatures if the vehicle is parked for long periods of time.

System settings after a battery change



If the 12 V vehicle battery is replaced or after a successful jump-start, system settings may be changed or deleted.

1. Check the date and time and adjust them if necessary.
2. Check personal convenience settings and adjust and save them as necessary.

 12 V vehicle batteries can contain toxic substances such as sulfuric acid and lead. Dispose of the 12 V vehicle battery according to legal and environmental regulations and only at a collection point for old batteries, e.g. a recycling center or specialist retailer.

 Battery acid can pollute the environment. Collect any leaking fluids and dispose of them according to legal and environmental regulations.

Checking the 12 V vehicle battery acid level

 Please read the introductory information and heed the Warnings and Notice ⇒  *Safety precautions for working in the hood space.*

The 12 V vehicle battery does not require any maintenance.

Check the acid level of the 12 V vehicle battery regularly if mileage is high, in countries with warm climates, or if the 12 V vehicle battery is old.

12 V vehicle battery location

The 12 V vehicle battery is located in the hood space.

Preparations

1. Prepare the vehicle for work in the hood space.
2. Wear suitable eye protection and safety gloves.
3. Open the hood.

Checking the Acid Level

WARNING

Battery acid is corrosive. Contact with battery acid, especially swallowing battery acid, can result in serious burns.

- Never open a 12 V vehicle battery.
- Never tilt the 12 V vehicle battery. Acid can leak out of the vent openings.
- Protect your skin, face, and particularly your eyes when working with the 12 V vehicle battery.
- Do not eat, drink, or smoke when working on the 12 V vehicle battery.
- Wash your skin with soap and water after working on the 12 V vehicle battery.
- If acid comes into contact with your skin or hair, remove all soiled or wet clothing and wash your skin and hair with water. Consult a doctor.
- If acid comes into contact with your eyes, rinse the affected area carefully with water for several minutes. Then

consult a doctor immediately.

- If you swallow battery acid, immediately drink plenty of water and swallow activated charcoal. Consult a doctor immediately.
- If you have inhaled acid vapors, leave the hazard area and breathe in fresh air. Consult a doctor immediately.

⚠ WARNING

When work is carried out on the 12 V vehicle battery, a highly explosive, flammable gas mixture builds up. Sparks could form and ignite the flammable gas that is released by the 12 V vehicle battery. This can result in serious injury or death.

- Always keep fires, sparks, open flames, and lit cigarettes far away from the 12 V vehicle battery.
- Avoid creating sparks when working with wires and electrical equipment or when discharging static electricity.

Depending on the vehicle equipment, an additional bracket must be removed to see the viewing window. An additional tool that is not available in the vehicle tool kit is required to do this. Always have the acid level of the 12 V vehicle battery checked by an authorized Volkswagen dealer or authorized Volkswagen Service Facility. Volkswagen recommends contacting an authorized Volkswagen dealer or authorized Volkswagen Service Facility.



Fig. 178 On the top of the 12 V vehicle battery: Window (general example).

Make sure there is enough lighting to clearly see the color indicator in the circular window on the top of the 12 V vehicle battery. [fig. 178.](#)

Light yellow or colorless

- The 12 V vehicle battery acid level is too low. Have the 12 V vehicle battery replaced by an authorized Volkswagen dealer or authorized Volkswagen Service Facility. Volkswagen recommends contacting an authorized Volkswagen dealer or authorized Volkswagen Service Facility.

Black

- The 12 V vehicle battery acid level is OK.

The acid level of 12 V vehicle batteries labeled AGM cannot be checked for technical reasons. Suitably qualified professionals can inspect the battery. Volkswagen recommends contacting an authorized Volkswagen dealer or authorized Volkswagen Service Facility.

Charging, replacing, disconnecting, or connecting the 12 V vehicle battery

 Please read the introductory information and heed the Warnings and Notice ⇒  *Safety precautions for working in the hood space.*

If you suspect that the 12 V vehicle battery is damaged or malfunctioning, see suitably qualified professionals to have the 12 V vehicle battery checked. Volkswagen recommends contacting an authorized Volkswagen dealer or authorized Volkswagen Service Facility.

Charging the 12 V vehicle battery

The 12 V vehicle battery should be charged by suitably qualified professionals because the 12 V vehicle battery that is installed at the factory requires a charging process where the voltage is limited ⇒ . Volkswagen recommends contacting an authorized Volkswagen dealer or authorized Volkswagen Service Facility.

Replacing the 12 V vehicle battery

The 12 V vehicle battery is designed to fit the location where it is installed and is equipped with safety features. If a 12 V vehicle battery needs to be replaced, have the replacement part fitted by qualified professionals. Check with qualified professionals to find out the component information regarding size and the required maintenance, performance, and safety features. They must possess the necessary technical documentation and equipment. Volkswagen recommends contacting an authorized Volkswagen dealer or authorized Volkswagen Service Facility. The vent opening on the 12 V vehicle battery must always be located on the negative terminal side. The vent opening on the positive terminal side must always be sealed ⇒ 

Only use a maintenance-free 12 V vehicle battery that conforms to the TL 825 06 and VW 7 50 73 standards. These standards must be from October 2014 or later.

Always have the 12 V vehicle battery replaced by qualified professionals because the vehicle electronics must be adapted as part of the replacement. Only qualified professionals have the necessary equipment to perform the adaptation and have access to the correct replacement batteries.

Disconnecting the 12 V vehicle battery

If the 12 V vehicle battery must be disconnected from the vehicle electrical system, note the following:

1. Switch off all electrical consumers.
2. Unlock the vehicle before disconnecting the battery. Otherwise, the anti-theft alarm system will be triggered.
3. Disconnect the negative cable first, and then the positive cable ⇒ .

Connecting the 12 V vehicle battery

If the 12 V vehicle battery must be connected to the vehicle electrical system, note the following:

1. Switch off all electrical consumers.
2. Connect the positive cable first, and then the negative cable ⇒ .

Various indicator lights may turn on after connecting the 12 V vehicle battery and switching the ignition on. They will turn off after driving a short distance at a speed of approx. 15 to 20 km/h (approx. 10 to 12 mph). If the indicator lights light up and remain on, contact an authorized Volkswagen dealer or authorized Volkswagen Service Facility and have the vehicle checked. Volkswagen recommends contacting an authorized Volkswagen dealer or authorized Volkswagen Service Facility.

If the 12 V vehicle battery was disconnected for a long period of time, the next scheduled maintenance may not display correctly or it may not be calculated correctly ⇒ *Service interval display*. Follow the maximum permissible service intervals ⇒ *Maintenance*.

Vehicles with a starter button: If the ignition cannot be switched on after connecting the 12 V vehicle battery, carry out the following activities:

1. Lock and unlock the vehicle from the outside.
2. Try to switch the ignition on again.
3. If the ignition will not switch on, see an authorized Volkswagen dealer or authorized Volkswagen Service Facility for assistance.

Automatic equipment deactivation

If the ignition is switched on for a very long time when the engine is off or the exterior lighting is switched on when parking for very long time, the intelligent power management cannot always prevent the 12 V vehicle battery from being discharged.

If the 12 V vehicle battery is under a heavy load, the intelligent power management will automatically begin certain measures to prevent the 12 V vehicle battery from draining.

- The idle speed will be increased so that the alternator delivers more power.
- If necessary, equipment that uses a lot of power will have its performance limited or will be switched off.
- The power supply to the 12 V socket will be interrupted temporarily when the engine is started.

12 V Vehicle Battery Draining

If the battery is drained, it may not be possible to start the engine. The 12 V vehicle battery will be drained in the following situations:

- If the vehicle is parked for long periods of time without running the engine, especially if the ignition is on.
- If electrical equipment is used when the ignition is switched off.

WARNING

Use of a 12 V vehicle battery that does not have identical specifications and dimensions to the 12 V vehicle battery that was installed at the factory may cause short circuits or fire. This could result in serious or fatal injuries.

- Always use a maintenance-free and leak-proof 12 V vehicle battery that has the same characteristics, specifications, and dimensions as the 12 V vehicle battery that was installed at the factory.

WARNING

Fitting 12 V vehicle batteries incorrectly may cause short circuits or fire. This could result in serious or fatal injuries.

- Always attach the 12 V vehicle battery to the attachment points provided in the vehicle.
- Replace all covers that are required for the vehicle back on the battery.

WARNING

A highly explosive mixture of oxyhydrogen can form when charging the 12 V vehicle battery. Sparks or naked flames could ignite the gas mixture. This could cause serious burns.

- Only charge 12 V vehicle batteries in well-ventilated areas.
- Keep sparks and naked flames away from the 12 V vehicle battery.

WARNING

If the degassing tube is not attached to the 12 V vehicle battery correctly, the highly explosive gas mixture that builds up when the vehicle is running may enter the vehicle interior. The flammable gas could ignite and cause serious injuries or death.

- For vehicles with the 12 V vehicle battery in the vehicle interior or luggage compartment, ensure that the degassing hose is connected to the 12 V vehicle battery correctly. The degassing hose must always be connected to the negative terminal side of the 12-volt vehicle battery.
- Always ensure that the opening on the positive terminal side of the 12 V vehicle battery is capped.

CAUTION

A drained 12 V vehicle battery can freeze at temperatures around 0 °C (+32 °F). Acid can escape from a frozen and defrosted 12 V vehicle battery. This can cause injuries and long-term damage to the vehicle.

- Never charge a frozen or thawed 12 V vehicle battery.
- Always replace the 12 V vehicle battery if it freezes.

CAUTION

Cables that are connected incorrectly can cause a short circuit. This could damage the on-board electronics and result in serious injuries.

- Connect the positive cable first and then the negative cable.

NOTICE

If the 12 V vehicle battery is connected or disconnected when the ignition is switched on or the engine is running, this could damage the electrical system or electronic components, resulting in electrical malfunctions.

- Never connect or disconnect the 12 V vehicle battery when the ignition is on or the engine is running.

NOTICE

If accessories that provide power for charging the 12 V vehicle battery are connected to the 12 V socket, this could damage the electrical system or electronic components, resulting in electrical malfunctions.

- Never connect accessories that provide power, such as solar panels or battery chargers, to the 12 V socket in order to charge the 12 V vehicle battery.

Troubleshooting

 Please read the introductory information and heed the Warnings and Notice ⇒  *Safety precautions for working in the hood space.*

12-volt power supply

The red warning light turns on.

 Do not continue driving! Possible failure of the electrical system.

A message is shown in the instrument cluster display.

1. Stop the vehicle immediately and park it safely.
2. Turn off electrical equipment that is not needed.
3. Stop the engine and switch the ignition off.
4. Contact an authorized Volkswagen dealer or authorized Volkswagen Service Facility for assistance.

If the red warning light comes on, the start-stop system is switched off. The start-stop system will only be automatically switched on again after the engine is restarted.

12-volt power supply

The yellow indicator light turns on.

A message regarding the battery charge level of the 12 V vehicle battery is shown in the instrument cluster display.

1. Let the engine run so that the 12 V vehicle battery can be recharged.
2. If the message about the battery charge level of the 12 V vehicle battery does not turn off after a few minutes despite the measures having been taken, then contact an authorized Volkswagen dealer or authorized Volkswagen Service Facility.

A message regarding the 12 V power supply is shown in the instrument cluster display.

1. Contact an authorized Volkswagen dealer or authorized Volkswagen Service Facility for assistance.

If the yellow indicator light lights up, the start-stop system will not be able to start the engine. If the yellow indicator light has turned off, the 12 V vehicle battery has a sufficient battery charge level to automatically restart the engine.

Wheels and tires

Introduction

Wheels are the parts of the vehicle that are under the most demand, yet are also the most underestimated. Wheels are very important because the narrow contact surfaces of the tires are the only contact that the vehicle has with the road.

The tire and rim combinations approved by Volkswagen are specifically designed for each other.

The service life of the tire depends on the tire pressure, the driving style, the way the tires are handled, and correct mounting of the tire.

Rims, tires and wheel bolts

Rims, tires, and wheel bolts are determined based on the vehicle model. Whenever another rim is installed, the wheel bolts to be used must have the correct length and bolt head shape. This ensures that the brakes can work correctly and that the vehicle drives smoothly and safely. For technical reasons, standard rims from other vehicles cannot be used. Under certain circumstances, this may even apply to rims for the same vehicle model. You must consult a suitably qualified professional to replace rim/tire combinations. Volkswagen recommends contacting an authorized Volkswagen dealer or authorized Volkswagen Service Facility.

The correct wheel bolts must always be used for each vehicle model, and these bolts must always be tightened to the correct torque ⇒ *Monitoring the tightening torque*.

Declaration of conformity for wheels and tires

Applies only to India: The tires fitted on the vehicle meet the requirements of BIS and the requirements of the Central Motor Vehicle Rules (CMVR), 1989.

WARNING

Incorrect handling of wheels can reduce driving safety and cause serious accidents and fatal injuries.

- Regularly check the tire pressure when the tires are cold and always maintain the specified pressure ⇒ *Checking the tire pressure*. If the tire pressure is too low, the tire can heat up so much while driving that the tread separates or the tire ruptures.
- Check the tires regularly for damage and wear.
- Never exceed the maximum permissible speed and tire load specified for the tires fitted to your vehicle.
- For all four wheels, use only radial tires of the same design, size (rolling circumference), and tread pattern.
- While driving, if unusual vibrations can be heard or the vehicle pulls to one side, stop immediately and check the wheels and tires for damage.
- Never loosen the bolts on rims with a bolted rim ring.
- Only perform work on the wheels if you have the necessary knowledge and tools.

WARNING

New tires or tires that are old, worn, or damaged cannot provide the maximum vehicle control and braking effect.

This can cause accidents and fatal injuries.

- Break in new tires because they have reduced traction and braking efficiency when they are new. Therefore drive carefully for the first 600 km (370 miles).
- Never drive with tires that are worn or damaged, e.g. punctured, cut, cracked, or bulging. If you are unsure whether

it is safe to continue driving, contact an authorized Volkswagen dealer or authorized Volkswagen Service Facility.

- While driving, if unusual vibrations can be heard or the vehicle pulls to one side, stop immediately and check the wheels and tires for damage.
- Do not use any tires or rims if you do not know how they have been used in the past. Used tires and rims may be damaged in a way that may not even be visible.
- Only use tires that are more than six years old if absolutely necessary and drive with extreme caution if doing so, even if the tires have never been used.
- Have worn or damaged tires replaced immediately by suitably qualified professionals. Volkswagen recommends contacting an authorized Volkswagen dealer or authorized Volkswagen Service Facility.

WARNING

If the wheel bolts are not tightened enough to meet the specification, the wheel bolts and consequently the wheel could come loose while driving. Exceeding the tightening specification could damage the wheel bolts and threads.

Wheel bolts that are tightened incorrectly or missing could cause you to lose control of the vehicle and lead to serious accidents and fatal injuries.

- Always tighten the wheel bolts to the correct tightening torque. If you do not have a torque wrench, tighten the wheel bolts with the lug wrench and then have the tightening torque checked as soon as possible by a suitably qualified professional. Volkswagen recommends contacting an authorized Volkswagen dealer or authorized Volkswagen Service Facility.
- Never drive with missing or loose wheel bolts.
- Always use wheel bolts that are correct for the rim and the vehicle model.
- Never grease or oil the wheel bolts and the threads in the wheel hub. Even when tightened to the specification, the wheel bolts could become loose while driving.
- Ensure the wheel bolts and threads in the wheel hubs are clean, easy to move and free of oil and grease.
- Never loosen the bolts on rims with a bolted rim ring.

WARNING

Improper installation of the tires on the rim can result in damage to the rim and cause tires to suddenly lose air or go flat while driving.

This can cause accidents and fatal injuries.

- Always have tires installed on the rim by an authorized Volkswagen dealer or authorized Volkswagen Service Facility. Volkswagen recommends contacting an authorized Volkswagen dealer or authorized Volkswagen Service Facility.

Taking care of wheels and tires

Handling tires

Preventing damage to the tires

- Always drive over curbs and other low obstacles slowly and at a right-angle so that both front wheels come into contact with the obstacle at the same time.

- There is a high risk of damage to tires and rims, especially for low-profile tires, on poor road surfaces or when driving on unpaved roads or off-road.
- Check the tire pressure regularly.
- Check tires regularly for damage, e.g. punctures.
- Never exceed the load index and maximum speed of the tire ⇒ *Tire labeling and tire classifications*.
- Have damaged or worn rims replaced immediately ⇒ *Troubleshooting*.
- Protect tires from coming into contact with corrosive materials such as grease, oil, gasoline, and brake fluid ⇒ .
- Replace missing dust caps on the valves immediately.
- Remove any objects provided they have not punctured the inside of the tire ⇒ *Troubleshooting*.
- Observe all tire pressure monitoring system warnings ⇒ *Troubleshooting the Tire Pressure Monitoring System*.

WARNING

Corrosive fluids and materials can cause visible and invisible damage to the tires, which can cause the tires to fail.

This can cause accidents and fatal injuries.

- Always keep chemicals, oils, grease, fuel, brake fluid, and other corrosive materials away from the tires.

Storing tires

- Only store tires in a cool, dry location that is as dark as possible.
- Do not stand tires that are mounted on rims up vertically.
- Protect tires that are not mounted on rims from dirt with suitable covers and store them standing on the tread surface.

Tires that are more than six years old

Tires age due to physical and chemical processes that affect their function. Tires that have been stored and unused for long periods of time age more quickly than tires that are used continuously.

Volkswagen recommends replacing tires that are more than six years old with new tires. This even applies to tires that may appear to be usable and whose tread depth is still greater than the minimum requirement ⇒ .

Winter and all season tires lose their characteristics to a large extent due to aging, regardless of the remaining tread depth.

The age of the tire can be determined based on the production date ⇒ *Tire labeling and tire classifications*.

WARNING

Old tires can suddenly lose air or rupture, particularly at high speeds.

This can cause accidents and fatal injuries.

- Only use tires that are more than six years old if absolutely necessary and drive with extreme caution if doing so, even if the tires have never been used.

New tires

- Drive particularly carefully during the first 600 km (370 mi) with new tires because they must be broken in. Tires that have not yet been broken in have reduced gripping abilities and braking efficiency ⇒ .
- Only use tires with the same design and as close to the same construction, size (rolling circumference) and tread pattern as possible on all four wheels.

- The tread depth of new tires may vary between tire models and manufacturers due to different design features and tread designs.

WARNING

New tires must be broken in because they have reduced traction and braking efficiency when they are new.

This could cause you to lose control of the vehicle and lead to serious accidents and fatal injuries.

- Break in new tires. Drive carefully for the first 600 km (370 miles).

 The size specifications for new tires may vary significantly from the actual tire dimensions for different tire brands.

Replacing tires

- At the factory, the vehicle can be equipped with reduced rolling resistance tires. The specified fuel consumption values can only be achieved using these tires. When purchasing new tires, always make sure the tires are optimized for rolling resistance ⇒ *Eco tips*.
- Before buying new reduced rolling resistance tires, seek advice from an authorized Volkswagen dealer or authorized Volkswagen Service Facility. Volkswagen recommends contacting an authorized Volkswagen dealer or authorized Volkswagen Service Facility.
- At a minimum, replace both tires on a single axle.
- Only replace old tires with tires that have been approved by Volkswagen for your vehicle model.
- Never use tires whose size exceeds the measurement of tires that are approved by Volkswagen ⇒ .

WARNING

Wheels must have enough clearance from vehicle components. If there is not enough clearance, tires could rub against components of the suspension, the body, and the brake lines.

This may cause the brake system to fail, the tread to separate, and the tire to rupture, resulting in serious accidents and fatal injuries.

- Only use tires with dimensions that do not exceed the dimensions of the tire brands approved by Volkswagen and that do not rub against other components of the vehicle.

Vehicles with tire pressure monitoring system

- When replacing the factory-installed wheels, make sure the new wheels are equipped with sensors that are compatible with the Tire Pressure Monitoring System ⇒ *Function of the Tire Pressure Monitoring System*.
- You must drive for a little while at a speed above approximately 25 km/h (approximately 15 mph) for the new wheels to be detected.

When replacing or reinstalling the sensors, Volkswagen recommends always using a new valve set and seal set.

Additional information about the Tire Pressure Monitoring System ⇒ *Function of the Tire Pressure Monitoring System*.

WARNING

Improper replacement or modification of the sensors of the tire pressure monitoring system can introduce leaks in the valves, causing the tire to lose air.

If the tire pressure is too low, the tire can heat up so much while driving that the tread separates or the tire ruptures, which

in turn can lead to serious accidents and/or serious injuries.

- Always use a new valve and seal kit when replacing or modifying the sensors.

WARNING

Dirt can damage the valves and introduce leaks, causing the tire to lose air.

If the tire pressure is too low, the tire can heat up so much while driving that the tread separates or the tire ruptures, which in turn can lead to serious accidents and/or fatal injuries.

- Never drive without caps on the valves.

NOTICE

Driving over potholes and curbs can cause the tires to become deformed.

Damage to the tires and rims can result.

- Avoid strong impacts and drive around obstacles where possible.

NOTICE

The valves can be damaged when replacing wheels.

- Do not let wheels that you have removed fall on the rim.

 Always dispose of old tires correctly and according to regulations.

 When replacing or modifying the sensors of the Tire Pressure Monitoring System, a new valve set and seal set must always be used. Otherwise the Tire Pressure Monitoring System may indicate there is a malfunction ⇒ [Troubleshooting the Tire Pressure Monitoring System](#).

 If the spare wheel is different from the regular vehicle wheels, e.g. in the case of winter tires or a compact spare wheel, only use the spare wheel temporarily in the event of a breakdown, and drive especially carefully. Replace the compact spare wheel with a regular wheel as soon as possible.

 Using tires approved by Volkswagen ensures that the dimensions will fit correctly on your vehicle. If other tires are used, the seller must provide a certificate from the tire manufacturer stating that the tires are suitable for the vehicle. Keep the certificate stored safely in the vehicle.

Handling rims

Preventing damage to the rims

- Missing hubcaps can cause damage to the rims and wheel bolts.

Always install missing hubcaps before driving.

- Always drive over curbs and other low obstacles slowly and at a right-angle so that both front wheels come into contact with the obstacle at the same time.
- Replace missing dust caps on the valves immediately.
- Check the tire pressure regularly.

Rims with bolted rim ring or accent elements

Rims with a bolted rim ring or accent element consist of multiple pieces. These pieces are connected together with special bolts. Damaged rims must be replaced and may only be repaired by suitably qualified professionals. Volkswagen recommends contacting an authorized Volkswagen dealer or authorized Volkswagen Service Facility.

Rim identification

In some countries, new rims must include information about certain properties. The following information may be on the rim:

- Seal of conformity
- Rim size
- Manufacturer or brand name
- Production date (month/year)
- Country of origin
- Serial number
- Raw material batch number
- Commodity code

WARNING

Using unsuitable or damaged rims can impair driving safety and cause accidents and serious injuries.

- Only use rims permitted for the vehicle.
- Check the rims regularly for damage and replace them if necessary.

WARNING

Loosening and tightening bolts incorrectly on rims with bolted rim rings can cause severe accidents and death.

- Never loosen the bolts on rims with a bolted rim ring.
- Have all procedures on rims with bolted rim rings performed by an authorized Volkswagen dealer or authorized Volkswagen Service Facility. Volkswagen recommends contacting an authorized Volkswagen dealer or authorized Volkswagen Service Facility.

Maintaining wheels and tires

Checking the tire pressure

Incorrect tire pressures negatively affect vehicle handling and can cause increased tire wear or even a flat tire ⇒ . Above all, the correct tire pressure is especially important when driving at high speeds.

- Check the tire pressure at least once a month.
- Check the tire inflation pressure of the spare wheel or compact spare wheel at least once a month.
- Check the tire pressure only when tires are cold. The specified tire pressure only applies to a cold tire. The tire pressure on warm tires is higher than on cold tires. Therefore, never release air from a warm tire to adjust the tire pressure.
- Always adjust the tire pressures to the vehicle load ⇒ .
- After adjusting tire pressures, always screw the caps on the valves and note the information about the tire pressure monitoring system.
- Always use the tire pressures specified on the label. Never exceed the maximum tire pressure specified on the side of th

tire.

- If the size of the tires installed at the factory differs from the details on the identification label or on the tire pressure label the correct tire pressure must be determined.

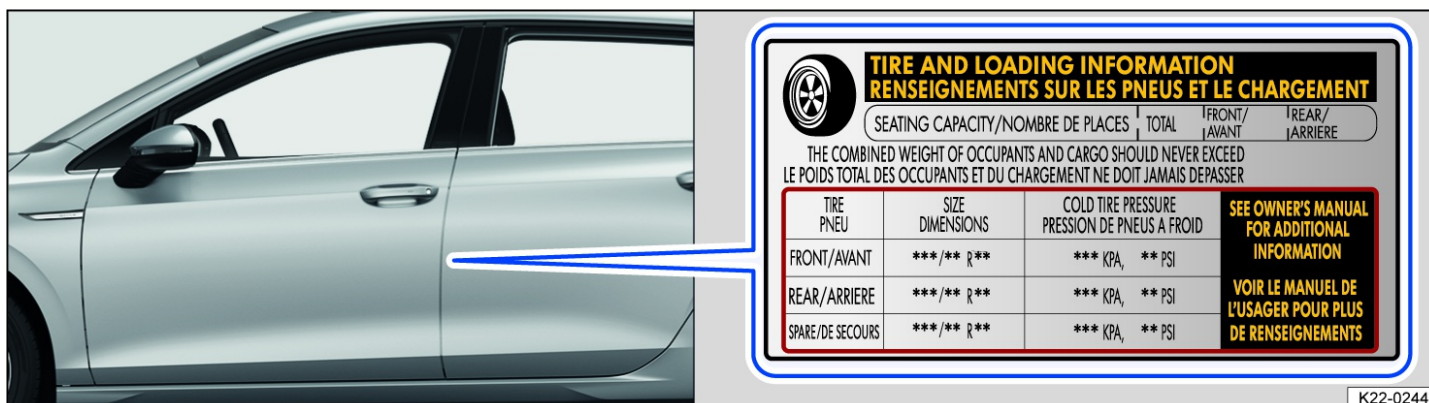

Fig. 179 On the driver door pillar: Tire inflation pressure label.

The tire inflation pressure label indicates the correct tire inflation pressure for approved tires and is located on the driver door pillar *fig. 179*. The factory-installed tires can be winter, summer or all-season tires.

An incorrect tire pressure can cause increased tire wear, negatively affect driving behavior and damage tires. Compliance with the correct tire pressure is very important, particularly when driving at high speeds.

The specified tire pressure is given for a cold tire. For warm tires, the pressure is higher.

Never reduce the pressure of a warm tire in order to reach the specified value. This will cause the actual pressure when the tire is cold to be too low.

⚠ WARNING

A tire pressure that is too low can result in a sudden loss of air, separation of the tire tread or bursting of the tire while driving. An incorrect tire pressure shortens the service life of the tire and negatively affects driving behavior.

An incorrect tire pressure can cause accidents and fatal injuries.

- Check the tire pressures regularly, at least once a month and also before driving long distances.
- Always adjust the tire pressure according to your load.
- Never reduce the tire pressure when tires are warm.

⚠ WARNING

Excessive speeds and vehicle overloading can cause overheating, sudden tire damage (including tire blow-outs) and separation of the tread.

This can cause accidents and fatal injuries.

- Never exceed the maximum load for the tires fitted ⇒ *Tire labeling and tire classifications*.
- Never exceed the maximum permitted speed for the tires fitted ⇒ *Tire labeling and tire classifications*.

ⓘ NOTICE

Careless handling of the tire pressure gage may damage the valve.

- When positioning the tire pressure gauge, make sure it is not tilted at the valve stem.

 Tire pressures that are too low increase fuel consumption.

Tire inflation pressure for cold tires

Size designation	Tire pressure
	psi/kPa
245/60 R 18	36 / 250
255/60 R 18	36 / 250
255/50 R 20	36 / 250
265/45 R 21	36 / 250
T165/80 R 17 (spare wheel)	60 / 420

Details of the correct tire pressure are located on the tire pressure label on the driver's door pillar. If the details on the tire pressure label differ from the details in the Manual, the details on the tire pressure label apply.

Monitoring the tightening torque

The correct wheel bolts must always be used for each vehicle model, and these bolts must always be tightened to the correct torque. The wheel bolt tightening torque must be checked regularly with a functional torque wrench. In addition, the tightening torque must be checked immediately after each wheel change with a functional torque wrench. If the wheel bolts are not tightened enough to meet the specification, the wheel bolts and consequently the wheel could come loose while driving. Exceeding the tightening specification could damage the wheel bolts and threads.

Wheel bolts that are corroded and difficult to turn must be replaced and the threads in the wheel hub must be cleaned before checking the tightening torque. Never grease or oil the wheel bolts and the threads in the wheel hub.

Wheel bolt tightening specification

The tightening torque of the wheel bolts is specified in the chapter on replacing wheels → page , *Changing a wheel*.

WARNING

If the wheel bolts are not tightened enough to meet the specification, the wheel bolts and consequently the wheel could come loose while driving. Exceeding the tightening specification could damage the wheel bolts and threads.

Wheel bolts that are tightened incorrectly or missing could cause you to lose control of the vehicle and lead to serious accidents and fatal injuries.

- Always tighten the wheel bolts to the correct tightening torque. If you do not have a torque wrench, tighten the wheel bolts with the lug wrench and then have the tightening torque checked as soon as possible by an authorized Volkswagen dealer or authorized Volkswagen Service Facility. Volkswagen recommends contacting an authorized Volkswagen dealer or authorized Volkswagen Service Facility.
- Never drive with missing or loose wheel bolts.
- Always use wheel bolts that are correct for the rim and the vehicle model.
- Never grease or oil the wheel bolts and the threads in the wheel hub. Even when tightened to the specification, the wheel bolts could become loose while driving.
- Ensure the wheel bolts and threads in the wheel hubs are clean, easy to move and free of oil and grease.

- Never loosen the bolts on rims with a bolted rim ring.

Replacing tires

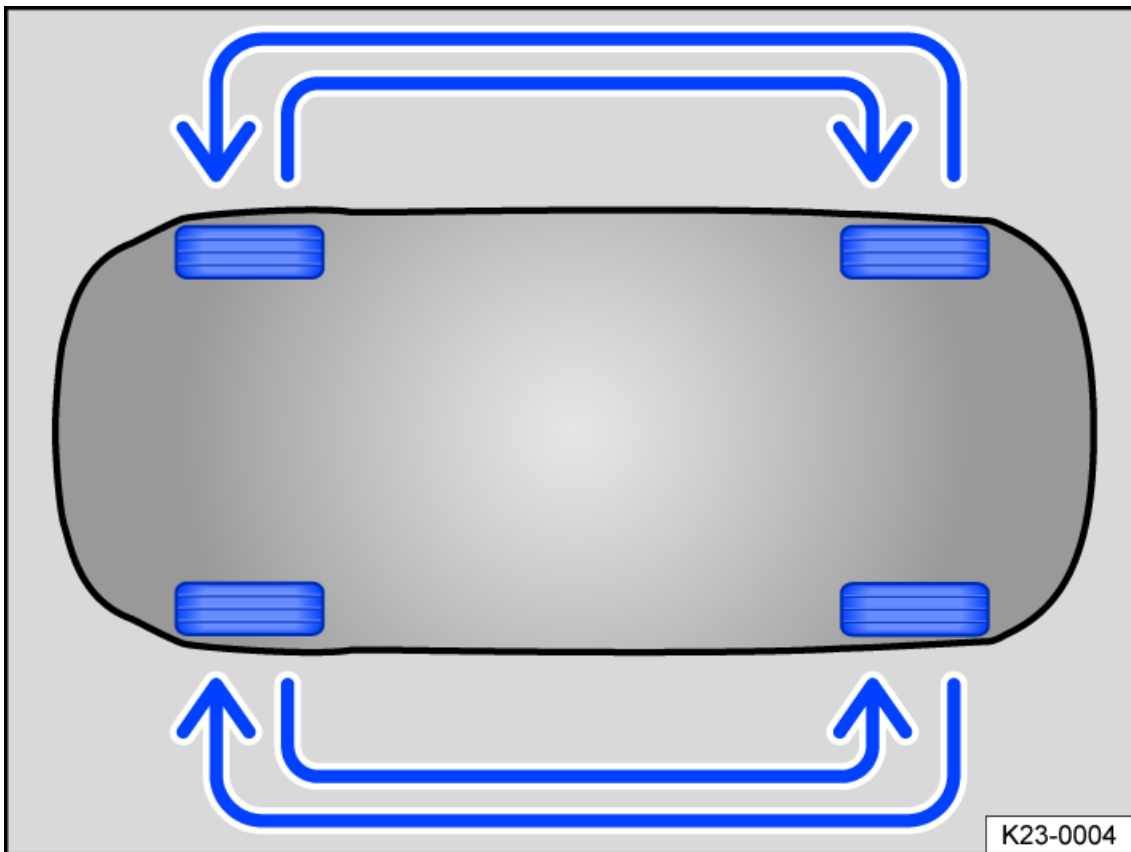

Fig. 180 Diagram for rotating the wheels (general example).

To ensure that the tires wear evenly, rotating the tires regularly according to the diagram is recommended *fig. 180*. This will allow the tires to have approximately the same length of service life.

Volkswagen recommends having the wheel replacement carried out by an authorized Volkswagen dealer or authorized Volkswagen Service Facility. Volkswagen recommends contacting an authorized Volkswagen dealer or authorized Volkswagen Service Facility.

Monitoring the tread depth

Tread depth

Most driving situations require a tire tread that is as deep as possible. All tires, or at least tires on the same axle, must have an even tread depth ⇒ ⚠. This applies in particular to wet or wintry road conditions.

In most countries, the legal minimum tread depth is 1.6 mm (1/16 of an inch). This is measured in the tread grooves next to the wear indicators. Observe any legal regulations specific to the country where you are driving.

Note the legal requirements in the applicable country for minimum tread depths on winter and all-season tires.

Tire wear

Tire wear depends on various factors:

- Driving style.
- Wheel balancing.
- Running gear alignment.

An imbalance can occur while driving, which can be noticed by uneven steering. Tire imbalances also affect tire wear. In these

situations, have the wheels balanced again.

Incorrect wheel alignment impairs driving safety and increases tire wear. If there is high degree of tire wear, have the wheel alignment checked by an authorized Volkswagen dealer or authorized Volkswagen Service Facility. Volkswagen recommends contacting an authorized Volkswagen dealer or authorized Volkswagen Service Facility.

Tire Wear when Driving with a Sporty Driving Style

Driving quickly around curves, rapid acceleration, and heavy braking increase tire wear.

If you drive with a sporty driving style, check the tread depth every 5000 to 10,000 km (approx. 3107 to 6214 miles).

Tread wear indicator in tires



Fig. 181 In the tread grooves: wear indicator.

The tread wear indicator is 1.6 mm (1/16 in) above the base of the tread [fig. 181](#). Markings on the sides of the tire indicate the location of the tread wear indicator [fig. 181](#).

The tread wear indicator indicates if a tire is worn out. At the latest, the tire must be replaced if the tread depth is worn down to the tread wear indicator.

When you check the tread depth, you must check the wear indicators of all tread grooves.

⚠ WARNING

Worn tires are a safety risk and make it difficult to control the vehicle well. They increase the braking distance and the risk of skidding.

Worn tires have significantly less grip. Particularly on wet roads, the vehicle is more likely to “hydroplane”.

Worn tires could cause loss of vehicle control, serious accidents and death.

- Replace tires with new tires when the tires are worn down to the tread wear indicator.

Wheels and tires in snow and ice

Winter tires

Summer tires offer very little holding force on icy or snowy roads. Winter or all-season tires improve vehicle handling and braking performance in winter road conditions. Volkswagen recommends using winter tires on the vehicle at temperatures

below +7 °C (+45 °F) or in winter road conditions. This also applies to vehicles with all-wheel drive (4MOTION).

The effectiveness of winter tires or all-season tires is greatly reduced when the tire tread is worn down to a depth of 4 mm (approx. 5/32 in).

The following applies when using winter tires:

- Follow all applicable laws in the country of operation.
- Use winter tires on all four wheels at the same time.
- Only use in winter road conditions.
- Only use the tire sizes permitted for the vehicle.
- Only use winter tires that have the same belt construction, size, and tread pattern ⇒ *Handling tires*.
- Follow the speed restriction based on the speed rating.

Speed restriction

Winter tires have a speed restriction based on their speed rating ⇒ *Tire labeling and tire classifications*.

A speed warning can be set in the Vehicle settings menu in the Infotainment System under the Tires menu.

On V winter tires, the speed restriction and required tire pressure depend on the engine. Always ask an authorized Volkswagen dealer or authorized Volkswagen Service Facility about the permitted speed and required tire pressure. Volkswagen recommends contacting an authorized Volkswagen dealer or authorized Volkswagen Service Facility.

WARNING

In winter road conditions, do not let the improved driving characteristics of winter tires tempt you to take safety risks, as otherwise you may lose control of the vehicle, resulting in serious injuries.

- Adapt your speed and driving style to the visibility, weather, road and traffic conditions.

 When temperatures are above +7 °C (+45 °F), summer tires provide better vehicle handling. There is less road noise, the tires wear more slowly, and economy is better.

 Winter tires fitted to vehicles with a tire pressure monitoring system must have sensors that are compatible with the tire pressure monitoring system to ensure that the system functions correctly ⇒ *Troubleshooting the Tire Pressure Monitoring System*. If the dimensions of the winter tires do not match the dimensions of the summer tires and require a different cold tire pressure, you will need to adapt the tire pressures for the tire pressure monitoring system ⇒ *Function of the Tire Pressure Monitoring System*.

 The speed limit and tire load of winter tires may differ from those of summer tires.

 You can contact an authorized Volkswagen dealer or authorized Volkswagen Service Facility for permitted winter tire sizes. Volkswagen recommends contacting an authorized Volkswagen dealer or authorized Volkswagen Service Facility.

Snow chains

Note the legal requirements and the permitted maximum speed when driving with snow chains.

Snow chains improve driving and braking handling when on roads covered with ice or snow.

Snow chains may only be mounted on the front wheels and only on the following tire/rim combinations:

Tire size	Rim
245/65 R 17	7 1/2 J x 17 ET 31

If possible, use fine-mesh snow chains that include a chain lock no larger than 13.5 mm (approx. 17/32 in).

Volkswagen recommends contacting an authorized Volkswagen dealer or authorized Volkswagen Service Facility for more information about wheel, tire, and snow chain sizes. Volkswagen recommends contacting an authorized Volkswagen dealer or authorized Volkswagen Service Facility.

Snow chains may only be used on tire/rim combinations that are approved for snow chain operation.

If using snow chains, remove the wheel covers and rim accent rings before mounting the snow chains. However, the wheel bolts must be covered with caps for safety reasons. Caps can be obtained from a suitably qualified professional. Volkswagen recommends contacting an authorized Volkswagen dealer or authorized Volkswagen Service Facility.

Using snow chains on the compact spare tire or collapsible spare tire

Using snow chains on the compact spare tire or collapsible spare tire is not permitted for technical reasons.

1. If a front tire is flat, mount the compact spare tire or collapsible spare tire on the rear axle.
2. Replace the damaged front wheel with the removed rear wheel. Pay attention to the running direction when doing this.

Volkswagen recommends attaching the snow chains before mounting the wheel.

WARNING

Using unsuitable snow chains or installing snow chains incorrectly can cause serious accidents and death.

- Always use the correct snow chains.
- Only use snow chains on the tire/rim combinations approved by Volkswagen.
- Follow the installation instructions provided by the snow chain manufacturer.
- Never drive faster than intended according to the specifications of the snow chain manufacturer or permitted by law when snow chains are mounted.

NOTICE

If snow chains are used on routes that are not snowy, they will impair the driving characteristics, damage the tires, and be quickly destroyed.

- Remove snow chains when driving on roads without snow.

NOTICE

Snow chains that come into contact with the rim directly can scratch or damage the rim.

- To prevent damage, use snow chains with integrated rim protection.

Troubleshooting

Damage to tires and rims can often occur where it is not visible ⇒ .

If you suspect that a wheel is damaged, slow down and stop as soon as traffic allows and it is safe to do so.

Vehicle pulls to one side or unusual vibrations

The vehicle pulls to the left or right when driving, or there are unusual vibrations. This could indicate tire damage or too low a tire inflation pressure.

Check the tires!

Slow down immediately and stop the vehicle as soon as the traffic situation allows and it is safe to do so.

1. Check the tires and rims for damage.
2. Do not continue driving if there is tire damage.
3. Replace the damaged wheel ⇒  [Introduction](#). If necessary, contact an authorized Volkswagen dealer or authorized Volkswagen Service Facility for assistance.
4. If no exterior damage is visible, drive slowly and carefully to the nearest authorized Volkswagen dealer or authorized Volkswagen Service Facility to have the vehicle checked. Volkswagen recommends contacting an authorized Volkswagen dealer or authorized Volkswagen Service Facility.

Foreign object stuck in the tire

A foreign object is stuck in the tire or between the tread segments.

1. If an object has punctured through to the inside of a tire, leave the object in place. Objects stuck between the tire tread segments can be removed.
2. Replace the damaged wheel ⇒  [Introduction](#). If necessary, contact an authorized Volkswagen dealer or authorized Volkswagen Service Facility for assistance.
3. Check and adjust the tire pressure.
4. Contact a suitably qualified professional. Volkswagen recommends contacting an authorized Volkswagen dealer or authorized Volkswagen Service Facility.

Tires lose traction

The vehicle loses traction when driving along curved stretches, and swerves. The braking distance is longer and the anti-slip regulation (ASR) and the anti-lock brake system (ABS) take control earlier.

The tire may be too worn down to guarantee sufficient traction ⇒ [Monitoring the tread depth](#).

1. Go slowly and carefully to the nearest suitably qualified professional to have the vehicle checked. Volkswagen recommends contacting an authorized Volkswagen dealer or authorized Volkswagen Service Facility.

Wheel bolts can only be undone with difficulty

Wheel bolts can corrode over time. This means that the wheel bolts can only be undone with difficulty.

1. Contact professional assistance, or drive slowly and carefully to the nearest qualified professional to have the vehicle checked. Volkswagen recommends contacting an authorized Volkswagen dealer or authorized Volkswagen Service Facility.

WARNING

Unusual vibrations or the vehicle pulling to one side while driving may indicate tire damage.

Tire damage could cause loss of vehicle control, accidents and serious or fatal injuries.

- Slow down immediately and stop the vehicle as soon as the traffic situation allows and it is safe to do so.
- Check tires and rims for damage such as punctures, cuts, tears, and bulges.
- Never continue driving with damaged tires or rims. Instead, seek professional assistance.
- If no exterior damage is visible, drive slowly and carefully to the nearest authorized Volkswagen dealer or authorized Volkswagen Service Facility to have the vehicle checked. Volkswagen recommends contacting an authorized Volkswagen dealer or authorized Volkswagen Service Facility.

Tire Pressure Monitoring System

Function of the Tire Pressure Monitoring System

The tire pressure monitoring system warns the driver if tire pressures are too low.

The tire pressure monitoring system (TPMS) monitors tire pressure in the four tires while driving using pressure sensors installed on the tires.

Each tire, including the spare (if provided), should be checked monthly when cold and inflated to the inflation pressure recommended by the vehicle manufacturer on the vehicle placard or tire inflation pressure label. (If your vehicle has tires of a different size than the size indicated on the vehicle placard or tire inflation pressure label, you should determine the proper tire inflation pressure for those tires).

As an added safety feature, your vehicle has been equipped with a tire pressure monitoring system (TPMS) that illuminates a low tire pressure telltale when one or more of your tires is significantly under-inflated. Accordingly, when the low tire pressure telltale illuminates, you should stop and check your tires as soon as possible, and inflate them to the proper pressure. Driving on a significantly under-inflated tire causes the tire to overheat and can lead to tire failure. Under-inflation also reduces fuel efficiency and tire tread life, and may affect the vehicle's handling and stopping ability.

Please note that the TPMS is not a substitute for proper tire maintenance, and it is the driver's responsibility to maintain correct tire pressure, even if under-inflation has not reached the level to trigger illumination of the TPMS low tire pressure telltale.

Your vehicle has also been equipped with a TPMS malfunction indicator to indicate when the system is not operating properly. The TPMS malfunction indicator is combined with the low tire pressure telltale. When the system detects a malfunction, the telltale will flash for approximately one minute and then remain continuously illuminated. This sequence will continue upon subsequent vehicle start-ups as long as the malfunction exists.

When the malfunction indicator is illuminated, the system may not be able to detect or signal low tire pressure as intended. TPMS malfunctions may occur for a variety of reasons, including the installation of replacement or alternate tires or wheels or the vehicle that prevent the TPMS from functioning properly. Always check the TPMS malfunction telltale after replacing one or more tires or wheels on your vehicle to ensure that the replacement or alternate tires and wheels allow the TPMS to continue to function properly.

Tire pressure display in the instrument cluster

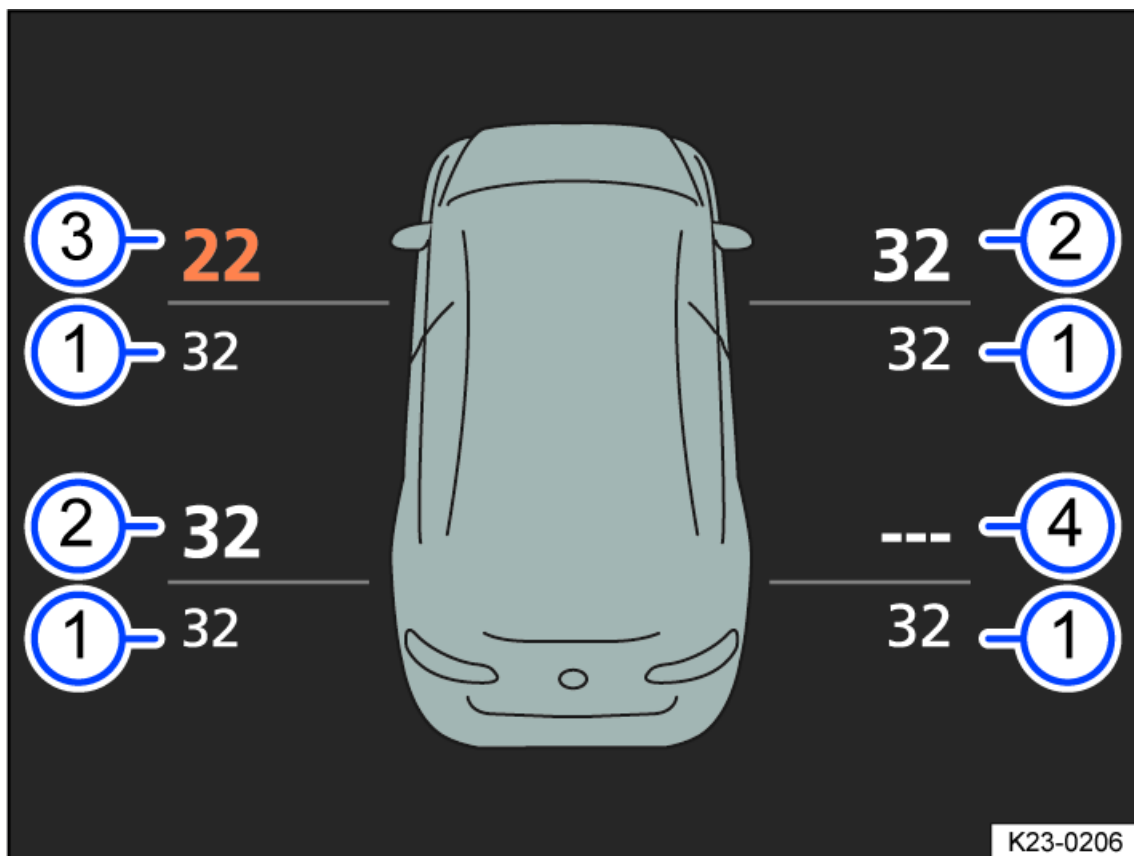

Fig. 182 Indicator in the instrument cluster display or Infotainment system: current tire pressures (general example).

- ① Specified pressure in psi.
- ② Actual pressure in psi.
- ③ Loss of pressure in the left front tire.
- ④ System malfunction in the right rear tire.

1. Open the Vehicle settings menu ⇒ [Vehicle settings menu](#).

Or: open the Vehicle status menu in the instrument cluster display.

The vehicle is shown with the actual and specified pressures for all tires [fig. 182](#).

When the ignition is switched on, the display initially shows the tire pressures that were last read by the system. When you begin driving, the display will update. If there is low tire pressure, the actual values and the affected tires will be marked in the display [fig. 182](#).

The sensors do not send any tire pressures when the tires are not moving. This helps to conserve the sensor batteries.

If no tire pressures are sent, the last tire pressures received will be shown in grey.

If a tire set that does not contain tire pressure sensors or whose tire pressure sensors are not compatible with the vehicle is installed, the (!) indicator light will blink for about one minute and then stay on. The tire pressures will not be monitored. It is not possible to switch the system off.

Follow the local applicable legal regulations regarding the tire pressure monitoring system.

WARNING

The tire pressure monitoring system is not a replacement for the driver's attention and works only within the system limitations. The tire pressure monitoring system cannot detect all driving situations and may not react, or may react with a delay, or may react in a way that is not desired. If you are careless, there is a risk of accidents, serious injuries and death.

- Always stay attentive and do not rely solely on the tire pressure monitoring system. The driver is always

responsible for maintaining the correct tire pressures.

- Observe the system limitations ⇒ *Limitations of the Tire Pressure Monitoring System*.
- Regularly check the tire pressure when the tires are cold and always maintain the specified pressures as stated on the tire inflation pressure label for the tires fitted on the vehicle ⇒ *Checking the tire pressure*.
- Check the tires regularly for signs of wear or damage and replace worn or damaged tires immediately.
- Never exceed the maximum permissible speed and tire load specified for the tires fitted to your vehicle.

WARNING

If you drive with insufficient tire pressure, the tire could become so hot that the tread could separate, the tire could rupture, and you could lose control of the vehicle.

Tire pressure that is too high or too low shortens the service life of the tire and affects driving behavior.

Different tire pressures or low tire pressures can increase tire wear, decrease vehicle stability, increase braking distance, and result in tire damage, tire failure and loss of vehicle control.

This can cause serious accidents and fatal injuries.

- Always pay attention to the warnings given by the tire pressure monitoring system. If the  warning light turns on, stop the vehicle immediately but safely with regard for other traffic and check all of the tires ⇒ *Checking the tire pressure*.
- The driver is responsible for maintaining the correct tire pressure. Regularly check the tire pressure when the tires are cold and always maintain the specified pressures as stated on the tire inflation pressure label for the tires fitted on the vehicle ⇒ *Checking the tire pressure*. The tire pressure monitoring system can only function correctly when all tires are inflated to the correct pressure when they are cold.
- If the tire is not “flat” and the tire does not need to be replaced immediately, drive slowly to the nearest authorized Volkswagen dealer or authorized Volkswagen Service Facility to have the tire pressure checked and corrected ⇒ *Checking the tire pressure*. Volkswagen recommends contacting an authorized Volkswagen dealer or authorized Volkswagen Service Facility.

WARNING

Excessive speeds and vehicle overloading can cause overheating, sudden tire damage (including tire blow-outs) and separation of the tread.

This can cause accidents and fatal injuries.

- Never exceed the maximum load for the tires fitted ⇒ *Tire labeling and tire classifications*.
- Never exceed the maximum permitted speed for the tires fitted ⇒ *Tire labeling and tire classifications*.

 Low tire pressure increases fuel consumption and tire wear.

 New tires may expand slightly the first time they are driven at high speeds, which can trigger a tire pressure warning.

 Only replace old tires with tires that have been approved by Volkswagen for the vehicle model.

 Do not solely rely on the tire pressure monitoring system. Inspect the tires regularly to make sure the tire pressure is correct and check the tires for any signs of damage, such as punctures. Remove any objects stuck in the tire tread as long as they have not punctured the inside of the tire.

Limitations of the Tire Pressure Monitoring System

Regular Maintenance

The tire pressure monitoring system is not intended to replace regular inspection and maintenance of the tires. The driver is responsible for ensuring that the correct tire pressure is used at all times, even if the tire pressure monitoring system is not showing a warning that the tire pressure is too low.

The tire pressure of all tires must be checked once a month when the tires are cold and must correspond to the vehicle manufacturer's specifications on the tire inflation pressure label.

This also applies to the tire pressure of the spare wheel or compact spare wheel.

The recommended tire pressure of the tire sizes approved by Volkswagen for the vehicle type is indicated on the tire pressure label ⇒ [Checking the tire pressure](#).

Transmission Malfunction

Transmitters that operate in the same band as the tire pressure sensors can temporarily stop the system from working properly ⇒ [Troubleshooting the Tire Pressure Monitoring System](#).

Spare wheel or compact spare wheel

The pressure of the spare wheel or compact spare wheel in the vehicle trunk is not monitored. The wheels in the luggage compartment are in idle mode.

! NOTICE

Handling the tire valves incorrectly can damage the pressure sensors and stop the tire pressure monitoring system from working properly.

- The pressure sensors are installed on special aluminum valves that are fixed in place. When filling and checking the tire pressure, do not bend the valves “into position”.
- The valves and sensors can be damaged if valve caps are missing. For this reason, always make sure all valve caps are fully tightened when driving.
- Do not use metal valve caps.
- Do not use “comfort valve caps”, because these do not form a seal and the sensors could be damaged. “Convenience valve caps” are valve caps that do not need to be unscrewed to inflate the tires.

Adjusting the Tire Pressure Monitoring System settings

Adapting tire pressures

The tire pressure must be checked and adapted each time the vehicle load changes. The recommended tire pressure for the vehicle is on the tire inflation pressure label ⇒ [Checking the tire pressure](#).

The values read by the pressure gage when inflating the tires may differ from the values detected by the TPMS. The TPMS is more accurate!

Selecting the Tire Size

When changing to a tire in a different size, it may be necessary to adapt the specified pressure of the Tire Pressure Monitoring System to the new tires. Contact an authorized Volkswagen dealer or authorized Volkswagen Service Facility to do so. Volkswagen recommends contacting an authorized Volkswagen dealer or authorized Volkswagen Service Facility.



If tires in a size that was not intended at the factory are installed, the specified pressure for these tires can be set by suitably qualified professionals. Volkswagen recommends contacting an authorized Volkswagen dealer or authorized Volkswagen

Troubleshooting the Tire Pressure Monitoring System

Tire pressure low

The yellow indicator light turns on.

Message: Flat tire! The pressure of one or more tires is below 1.4 bar (20 psi/140 kPa) or there is a critical loss of tire pressure.

1.  Stop the vehicle immediately where it is safe to do so. Only turn the steering wheel slightly and slowly, and brake carefully.
2. Check the tires for visible damage ⇒ [Troubleshooting](#).
3. If there is no visible damage on the tires, drive at reduced speed to the nearest gas station and check the tire pressure. Adjust it if necessary.
4. If one of the tires is damaged, change the damaged wheel ⇒  [Introduction](#). If necessary, contact an authorized Volkswagen dealer or authorized Volkswagen Service Facility for assistance.

The yellow indicator light turns on.

Message: Tire pressures are too low. This warning indicates a critical loss of pressure in at least one tire.

1. Drive on carefully and go to the nearest gas station immediately. Only turn the steering wheel slightly and slowly, and brake carefully.
2. Check the pressure in all tires and adjust it if necessary ⇒ [Checking the tire pressure](#).
3. If the tires cannot maintain the tire pressure, get the tires replaced.

Or: replace the damaged wheel with a spare wheel or compact spare wheel and contact an authorized Volkswagen dealer or authorized Volkswagen Service Facility. Volkswagen recommends contacting an authorized Volkswagen dealer or authorized Volkswagen Service Facility ⇒ [Wheel change](#).

Message: Please check the tire pressures. The warning indicates a minor loss of pressure in at least one tire.

1. Avoid driving long distances and at high speeds when the message is displayed.
2. Check the pressure in all tires and adjust it if necessary ⇒ [Checking the tire pressure](#).

Tire pressure monitoring system malfunction

The yellow indicator light flashes for approximately one minute and then stays on.

One or more tires with tire pressure monitoring sensors were installed but not detected.

1. Drive for a few minutes until the indicator light turns off.

One or more tires without tire pressure monitoring sensors were installed or a tire pressure monitoring sensor is malfunctioning.

1. Install tires with functioning tire pressure monitoring sensors.

There is a malfunction between a sensor and the system. Because of overlap among sensors that function in the same frequency range, the system function may be temporarily impaired.

1. Switch off or avoid using sources of interference, such as mobile devices, remote controls, or children's toys.

There is a system malfunction.

1. Switch the ignition off and back on again. If the malfunction persists, contact a suitably qualified professional. Volkswagen recommends contacting an authorized Volkswagen dealer or authorized Volkswagen Service Facility.

Wheel change

Introduction

Only change the wheel yourself if the vehicle is parked securely, you are familiar with the safety precautions and the necessary procedures and you have the necessary tools. Some vehicles are delivered from the factory without a vehicle jack and lug wrench. In such cases, have the wheel changed by an authorized Volkswagen dealer or authorized Volkswagen Service Facility. Volkswagen recommends contacting an authorized Volkswagen dealer or authorized Volkswagen Service Facility.

If the vehicle is delivered ex works with a jack, this jack may only be used if one wheel on the vehicle has been damaged and needs to be replaced. If both tires on one side of the vehicle, or both tires on one axle, or all tires are damaged, do not use the jack delivered ex works. Instead, contact a suitably qualified professional. Volkswagen recommends contacting an authorized Volkswagen dealer or authorized Volkswagen Service Facility.

You must carry out the following steps to change a wheel.

1. Prepare the vehicle for the wheel change ⇒ [Preparing Your Vehicle](#).
2. Depending on the vehicle and vehicle equipment, remove the subwoofer ⇒ [Removing and installing the subwoofer](#).
3. Take out the spare wheel ⇒ [Removing the spare wheel or compact spare wheel](#).
4. Remove the wheel hub cover or wheel bolt caps ⇒ [Removing and Fitting the Wheel Bolt Caps](#).
5. Loosen the wheel bolts ⇒ [Loosening wheel bolts](#).
6. Jack up the car ⇒ [Raising the vehicle with the vehicle jack](#).
7. Remove the damaged wheel and fit the spare wheel or compact spare wheel ⇒ [Changing a wheel](#).



WARNING

It can be dangerous to change a wheel at the roadside.

If the vehicle and work area are not secured properly, serious accidents and fatal injuries may occur.

- Only carry out the wheel change yourself if you are familiar with the necessary steps. Instead, seek assistance from an authorized Volkswagen dealer or authorized Volkswagen Service Facility. Volkswagen recommends contacting an authorized Volkswagen dealer or authorized Volkswagen Service Facility.
- Stop the vehicle as soon as it is safe to do so.
- To reduce the risk of the vehicle moving unintentionally, park the vehicle properly at a safe distance from moving traffic ⇒ [Parking](#).
- Set the electronic parking brake.
- Move all passengers, particularly children, to a safe distance away from the working area on the side facing away from moving traffic.
- Switch on the emergency flashers to warn other road users and set up the warning triangle.
- Only jack up the vehicle on level, firm ground. Sloped or soft ground can cause the vehicle to slip off the jack. If necessary, place a large, stable surface under the jack.
- If you are on a slippery surface such as tile, place a non-slippery object such as a rubber mat on the ground to prevent the jack from slipping.
- Only use suitable and undamaged tools for wheel changes.
- After changing a wheel, immediately check the tightening torque of the wheel bolts with an undamaged torque wrench that is functioning correctly.

Preparing Your Vehicle

 Please read the introductory information and heed the Warnings and Notice ⇒  *Introduction*.

Checklist

Always perform the following steps in the specified order to prepare for a wheel change ⇒ :



1. Park the vehicle a safe distance from moving traffic. Observe all important information on parking when doing so ⇒ *Parking*. The ground must be level and firm. Sloped or soft ground can cause the vehicle to slip off the jack. If necessary, place a large, stable surface under the vehicle jack.
2. Switch on the emergency flashers ⇒ *Center console*.
3. Have all vehicle occupants exit the vehicle on the side facing away from traffic and move to a safe area, such as behind a guard rail. Follow the local regulations regarding wearing a reflective vest.
4. Set up the warning triangle to warn others on the road about the vehicle.
5. Adjust the steering wheel so that the wheels are not pointing straight forward.
6. Block the tire that is diagonal from the one you will be changing with a stone, chocks, or another suitable object.
7. In trailer mode: Disconnect the trailer from the towing vehicle and park it ⇒ *Trailer towing*.
8. If the luggage compartment is full: remove the contents from the luggage compartment.
9. Depending on the vehicle and vehicle equipment, remove the subwoofer ⇒ *Removing and installing the subwoofer*.
10. Remove the collapsible spare wheel, full-size spare wheel or compact spare wheel and the vehicle tool kit from the luggage compartment.

WARNING

Failing to heed this checklist that is provided for your own safety can cause accidents and serious injuries.

- Always follow the tasks in the checklist.
- Observe the general safety precautions.

Removing and installing the subwoofer

 Please read the introductory information and heed the Warnings and Notice ⇒  *Introduction*.

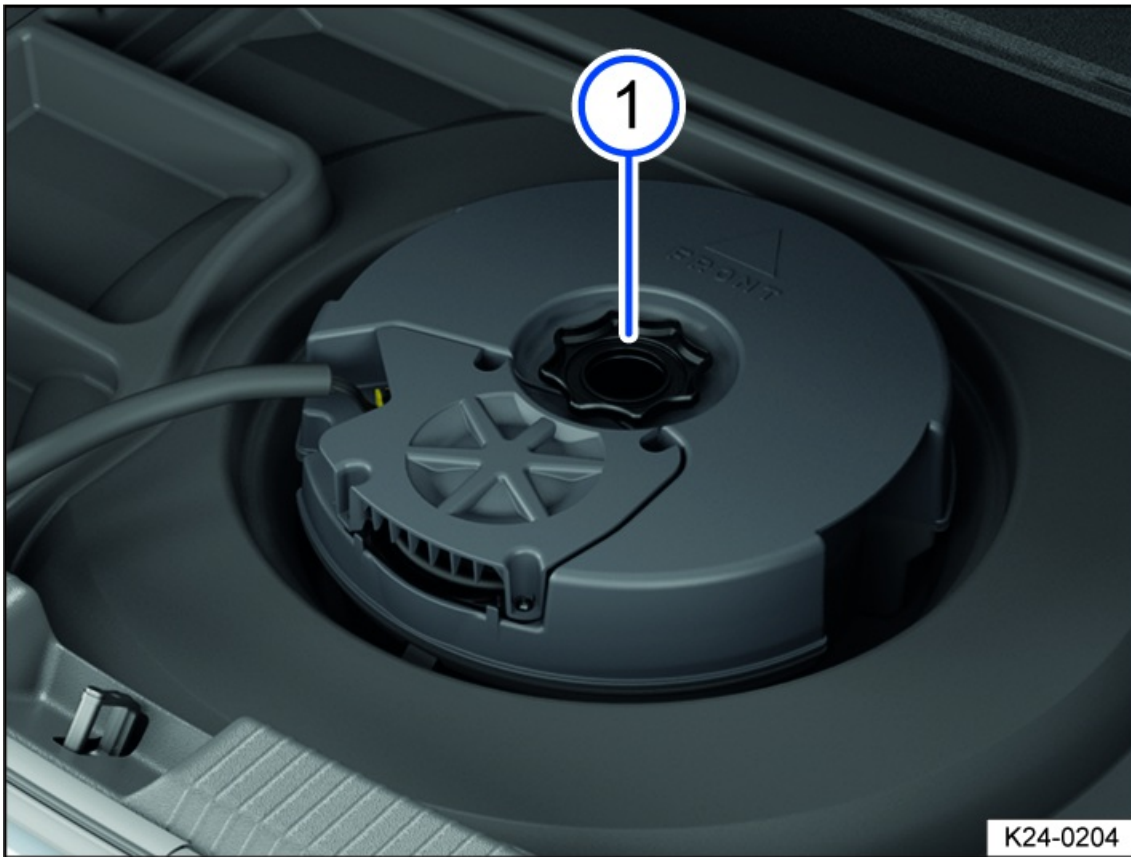

Fig. 183 Under the luggage compartment floor: removing the subwoofer.



Fig. 184 In the luggage compartment: leaning the subwoofer.

Before you can remove the spare wheel, you must remove the subwoofer and lean it in the luggage compartment.

Removing the subwoofer

1. Open the trunk lid and hook the floor covering onto the upper edge of the luggage compartment.
2. Unscrew the handwheel *fig. 183* ① counterclockwise.

3. Lift the subwoofer out carefully.
4. Lift out the subwoofer and lean it against the side panel of the luggage compartment, ensuring that the subwoofer cannot tip or fall *fig. 184*.

Installing the subwoofer



1. Carefully place the subwoofer in the recess of the spare wheel cover. The arrow symbol with the word "FRONT" on the subwoofer must point forward *fig. 183*.
2. Turn the handwheel *fig. 183*  clockwise until the subwoofer is securely in place.
3. Unhook the floor covering and fold it back into place on the luggage compartment floor.

NOTICE

Leaking liquids in the luggage compartment can damage the subwoofer.

- Immediately remove any spilled liquids, e.g. with a dry cloth.

Removing the spare wheel or compact spare wheel

 Please read the introductory information and heed the Warnings and Notice \Rightarrow  *Introduction*.

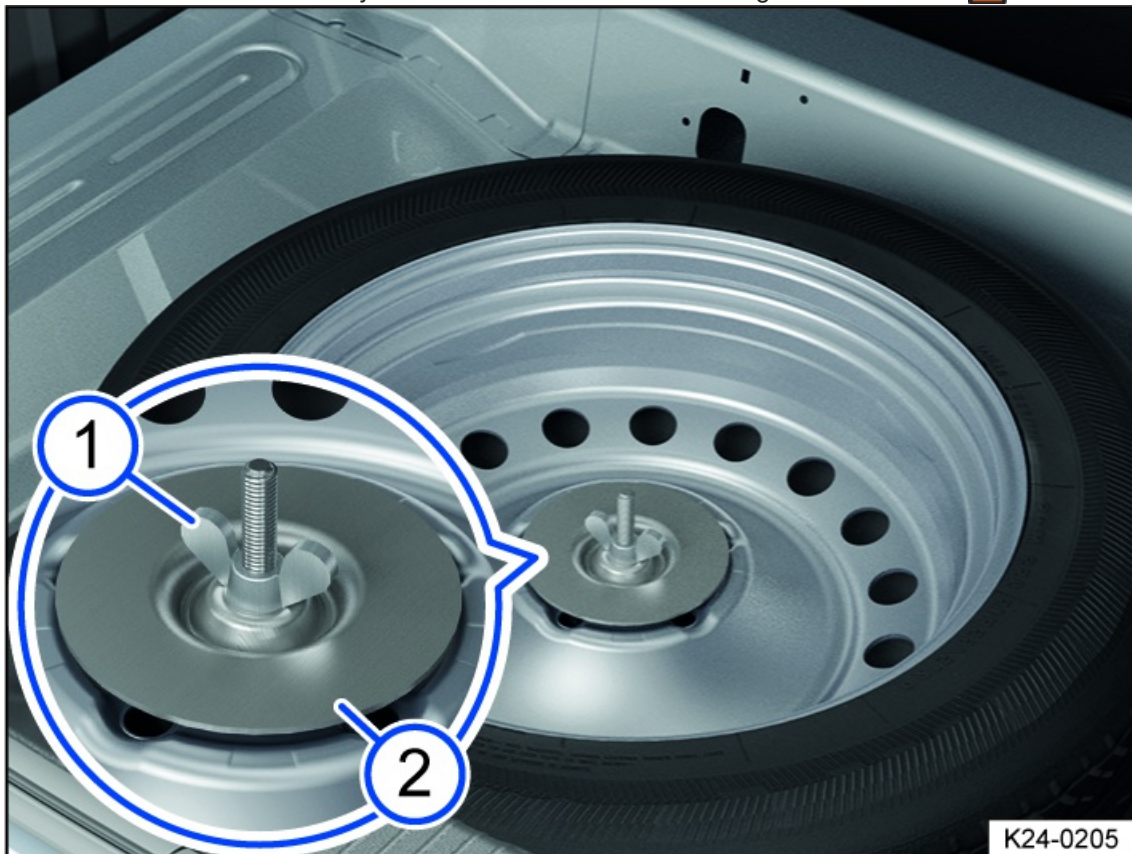





Fig. 185 Under the luggage compartment floor: wing nut to secure the spare wheel or compact spare wheel.

Removing the spare wheel or compact spare wheel

1. Open the trunk lid.
2. Lift up or remove the luggage compartment floor.
3. If present, lift up and remove the carpet.
4. Remove the vehicle tool kit with the container.
5. Depending on the vehicle and vehicle equipment, remove the subwoofer \Rightarrow *Removing and installing the subwoofer*.
6. Removing the spare wheel cover.

7. Unscrew the wing nut *fig. 185*  in the center of the spare wheel all the way counterclockwise.
8. Remove the lock washer *fig. 185* .
9. Remove the spare wheel or compact spare wheel.

Stowing the removed tire

1. If the removed wheel fits in the spare wheel well: place the removed wheel with the front of the rim facing down into the spare wheel well so that the center hole on the rim is directly above the hole or the threaded pin.
If the removed wheel does not fit in the spare wheel well, securely stow the wheel in the luggage compartment on the luggage compartment floor.
2. Slide the lock washer *fig. 185*  onto the threaded pin.
3. Turn the wing nut *fig. 185*  clockwise onto the threaded pin until the replaced wheel is securely fastened.
4. Install the spare wheel cover.
5. Depending on the vehicle and vehicle equipment: install the subwoofer ⇒ *Removing and installing the subwoofer*.
6. Place the vehicle tool kit back in the container and stow it in the luggage compartment.
7. Place the carpet (if there is one) in the luggage compartment.
8. Reinsert the luggage compartment floor or fold back down.
9. Close the trunk lid.

If the spare wheel is different from the regular tires

If the spare wheel is different from the regular wheels, then the spare wheel must only be used in the event of a vehicle breakdown and only for a short period of time ⇒ .

Note the driver information:

- Do not drive faster than 80 km/h (50 mph).
- Avoid hard acceleration, heavy braking, and fast cornering.
- Do not use snow chains on the compact spare wheel ⇒ *Snow chains*.
- After installing the spare wheel or compact spare wheel, check the tire pressure as soon as possible ⇒ *Checking the tire pressure*.

The tire pressure of the spare wheel or compact spare wheel must be checked every time the tire pressure of the regular wheels is taken, or at least once a month. The tire pressure of the spare wheel or compact spare wheel when the tires are cold must correspond to the details on the tire inflation pressure label ⇒ *Checking the tire pressure*.

WARNING

Incorrect handling of the spare wheel or compact spare wheel can result in loss of vehicle control, serious accidents or death.

- Never use the spare wheel or compact spare wheel if it is damaged or if it is worn down to the wear indicator.
- If the spare wheel is different from the regular wheels or you are using a compact spare wheel, never drive faster than 80 km/h (50 mph).
- Some vehicles may be equipped with a compact spare wheel instead of a spare wheel. The compact spare wheel can be identified by a label stating “80 km/h” or “50 mph”. This label indicates the permitted maximum speed at which the tire may be driven. Do not cover the sticker while the wheel is in use.
- Never drive more than 200 km (125 miles) with a temporary compact spare wheel fitted to the drive axle.
- Avoid hard acceleration, hard braking, and driving fast around curves.

- Replace the compact spare wheel as soon as possible with a regular wheel. The spare wheel is only intended for short-term use.
- Always secure the compact spare wheel with the wheel bolts supplied by the factory.
- Never drive with more than one compact spare wheel.
- Never drive with more than one spare wheel that differs from the regular tires.
- After mounting the spare wheel or compact spare wheel, check the tire pressure as soon as possible ⇒ *Checking the tire pressure*.
- Do not use snow chains on the compact spare wheel.
- Never mount a compact spare wheel on the rear axle when in trailer mode ⇒ *Trailer towing*.

Removing and Fitting the Wheel Bolt Caps

📖 Please read the introductory information and heed the Warnings and Notice ⇒ ⚠️ *Introduction*.

Removing the Caps



Fig. 186 Remove the caps from the wheel bolts.

The caps are for protecting the wheel bolts and must be completely reattached after a wheel change.

1. Take the extraction hook out of the vehicle tool kit ⇒ *Vehicle tool kit components*.
2. Insert the extraction hook into the opening in the cap.
3. Remove the cap with extraction hook in the direction of the arrow *fig. 186*.

Putting on Caps

1. Push the cap all the way onto the wheel bolts.

Loosening wheel bolts



Fig. 187 Loosening wheel bolts.

Use a suitable lug wrench to loosen the wheel bolts.

Only loosen the wheel bolts a few turns while the vehicle is not raised with the vehicle jack.

1. Slide the lug wrench all the way onto the wheel bolt.
2. Hold the end of the lug wrench and turn the wheel bolt about one turn counterclockwise ⇒ ⚠️.

i If a wheel bolt cannot be loosened, carefully press on the end of the lug wrench using your foot. Hold onto the vehicle firmly while doing this and make sure you have secure footing.

⚠️ WARNING

If the wheel bolts are removed or loosened by more than one rotation before the vehicle is jacked up, the wheel could fall off and the vehicle might tip.

This can result in serious injuries.

- Only loosen the wheel bolts about one turn while the vehicle is not lifted with the jack.
- Never place any part of your body, such as your arm, under the vehicle while you loosen the wheel bolts.

Raising the vehicle with the vehicle jack

📖 Please read the introductory information and heed the Warnings and Notice ⇒ ⚠️ *Introduction.*

Lift points

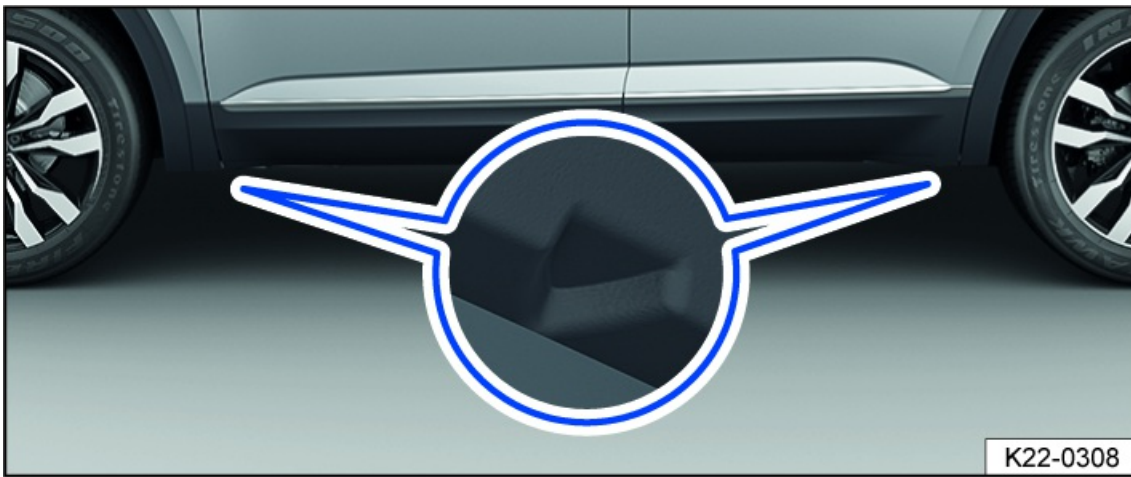

Fig. 188 On the side sill: markings for the jack lift points.

The vehicle jack must only be positioned at the reinforced areas on the underbody that are located behind the markings on the vehicle body *fig. 188*. Always use the lift point that is nearest to the wheel you are changing ⇒ ⚠.

Positioning the vehicle jack

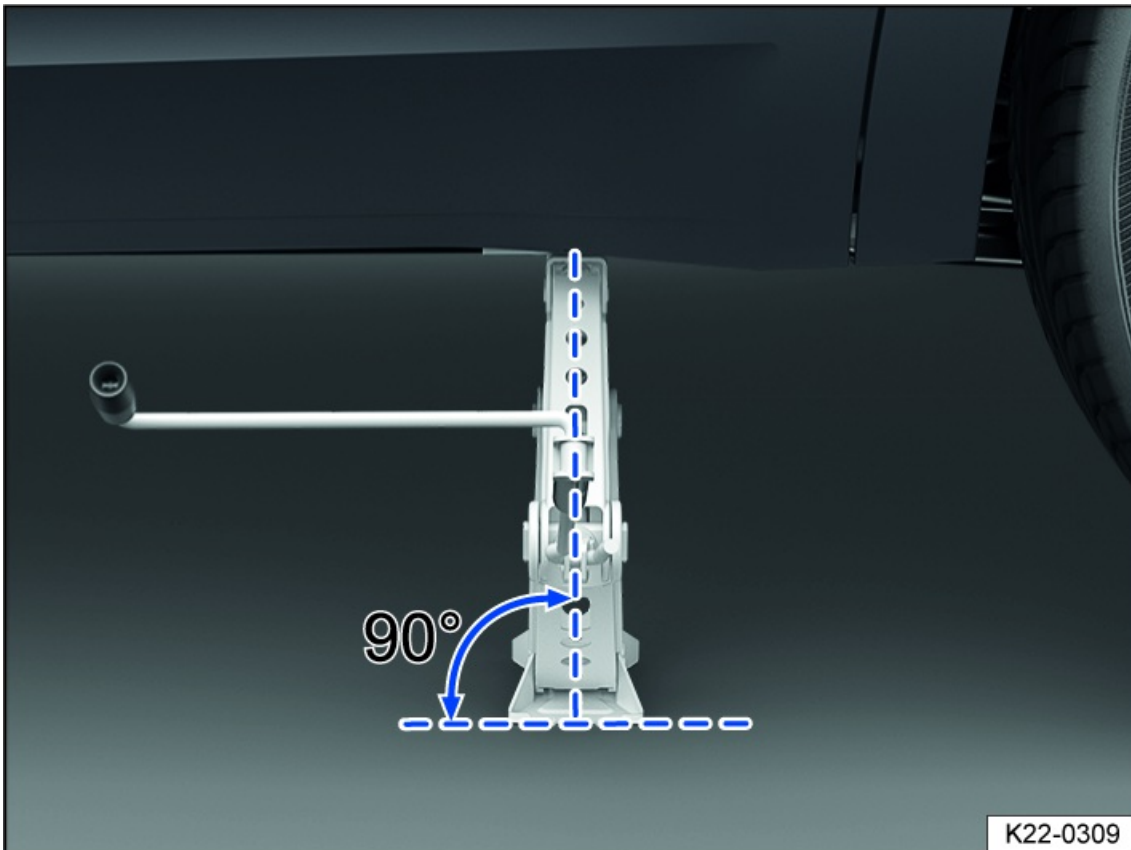

Fig. 189 Correct jack setup.

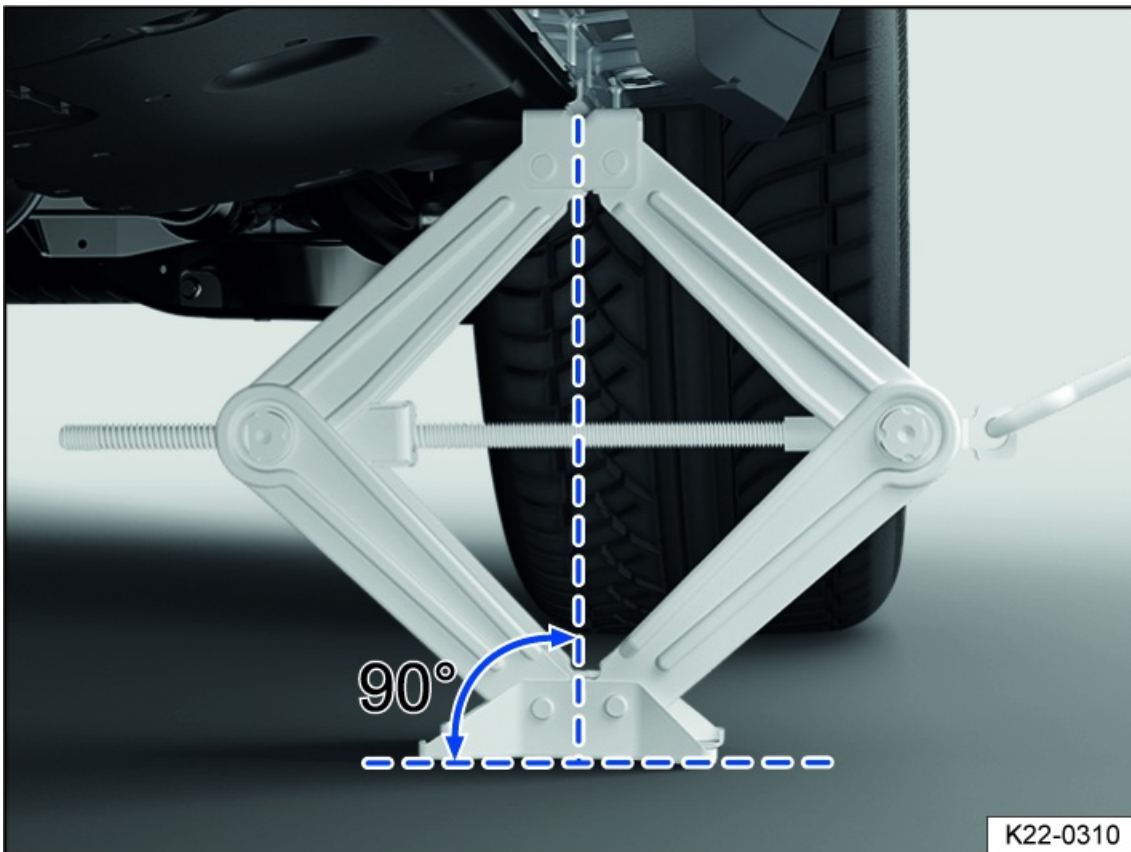

Fig. 190 On the left side of the vehicle at the rear: jack in position.

Checklist

For your own safety, follow the points below in the order they are given ⇒ ⚠ :

1. Position the hand crank in the mount on the jack.
2. Find the jacking point *fig. 188* under the vehicle that is closest to the wheel you will be changing.
3. Crank the jack upward so that it is still positioned under the vehicle lift point.
4. Make sure the entire base of the jack is seated securely on the ground and that the base of the jack is located exactly directly below the lift point *fig. 189* and *fig. 190*.
5. Straighten the jack and continue cranking the claw on the top of the jack upward until the claw is positioned on the jacking point under the vehicle *fig. 190*.
6. Continue raising the vehicle jack until the wheel is lifted off the ground.

⚠ WARNING

Failing to heed this checklist that is provided for your own safety can cause accidents and serious injuries.

- Always follow the tasks in the checklist.
- Observe the general safety precautions.

⚠ WARNING

Using the vehicle jack incorrectly can cause the vehicle to slip from the jack, resulting in serious injuries or death.

- Never raise the vehicle if more than one wheel is damaged.
- Never jack up the vehicle when the engine is running.
- Never start the engine if the vehicle is raised. Engine vibrations could cause the vehicle to fall off the jack.

- Only place the vehicle jack at the lift points described. The bracket on the vehicle jack must firmly grip the sill [fig. 190](#).
- Only use jacks that are approved by Volkswagen for the vehicle. Other vehicle jacks, including those approved for other Volkswagen models, could slip.
- Only jack up the vehicle on level, firm ground. Sloped or soft ground can cause the vehicle to slip off the jack. If necessary, place a large, stable surface under the jack.
- If you are on a slippery surface such as tile, place a non-slippery object such as a rubber mat on the ground to prevent the jack from slipping.
- Never place any part of your body, such as your arm, under the vehicle when it is supported only by the jack. If you must work underneath the vehicle, additionally support the vehicle securely with suitable stands.

Changing a wheel

📖 Please read the introductory information and heed the Warnings and Notice ⇒ [⚠ Introduction](#).

Removing a wheel



Fig. 191 Removing wheel bolts with the lug wrench.

1. Follow the checklist ⇒ [Preparing Your Vehicle](#).
2. Loosen the wheel bolts and fit the mounting pin ⇒ [Loosening wheel bolts](#).
3. Raise the vehicle ⇒ [Raising the vehicle with the vehicle jack](#).
4. Remove loose wheel bolts completely using the lug wrench [fig. 191](#) and place the bolts on a clean surface.
5. Remove the wheel.

Installing a spare wheel or compact spare wheel

1. Note the running direction of the tire ⇒ [Tire labeling and tire classifications](#).
2. Position the wheel.

3. Screw in four wheel bolts.
4. Remove the mounting pin and screw in the remaining wheel bolts.
5. Use the adapter to help if you have anti-theft wheel bolts.
6. Lower the vehicle with the vehicle jack.
7. Tighten each wheel bolt securely clockwise with the lug wrench ⇒ . Do not go in order around the wheel while doing this, but rather always switch to a wheel bolt on the opposite side.
8. Fit the caps or hubcap ⇒ *Removing and Fitting the Wheel Bolt Caps*.

After a wheel change

1. Clean the vehicle tool kit and place it back in the foam piece in the luggage compartment.
2. Stow the old wheel securely in the luggage compartment.
3. Get the tightening torque of the wheel bolts checked as soon as possible at the nearest authorized Volkswagen dealer or authorized Volkswagen Service Facility. Volkswagen recommends contacting an authorized Volkswagen dealer or authorized Volkswagen Service Facility.
4. Get the damaged tires replaced as soon as possible.

Wheel bolt tightening specification

Tightening specification for wheel bolts in steel and aluminum alloy rims:

- **120 Nm (88 ft-lbs).**

Wheel bolts that are corroded and difficult to turn must be replaced and the threads in the wheel hub must be cleaned before checking the tightening torque.

Never grease or oil the wheel bolts and the threads in the wheel hub.

Check the tightening torque using a functioning torque wrench immediately after changing a wheel.

WARNING

If the wheel bolts are not tightened enough to meet the specification, the wheel bolts and consequently the wheel could come loose while driving. Exceeding the tightening specification could damage the wheel bolts and threads.

Wheel bolts that are tightened incorrectly or missing could cause you to lose control of the vehicle and lead to serious accidents and fatal injuries.

- Always tighten the wheel bolts to the correct tightening torque. If you do not have a torque wrench, tighten the wheel bolts with the lug wrench and then have the tightening torque checked as soon as possible by a suitably qualified professional. Volkswagen recommends contacting an authorized Volkswagen dealer or authorized Volkswagen Service Facility.
- Never drive with missing or loose wheel bolts.
- Always use wheel bolts that are correct for the rim and the vehicle model.
- Never grease or oil the wheel bolts and the threads in the wheel hub. Even when tightened to the specification, they could become loose while driving.
- Ensure the wheel bolts and threads in the wheel hubs are clean, easy to move and free of oil and grease.
- Never loosen the bolts on rims with a bolted rim ring.

WARNING

Incorrect wheel bolts can loosen while driving and cause loss of vehicle control, serious accidents, and fatal injuries.

- Always use wheel bolts that are correct for the rim and the vehicle model.
- Never use different wheel bolts.
- Use only two-piece wheel bolts on vehicles with two-piece wheel bolts.

i The tire pressure monitoring system indicator light may indicate a system malfunction after a wheel is changed (⚠). If the spare wheel or compact spare wheel has been fitted, the engine indicator light may light up (🚗) because the spare wheel or compact spare wheel has a different tire diameter to the original tires. Contact the nearest suitably qualified workshop if the engine indicator light remains on after changing to the original tires and after three consecutive journeys, or after 120 km (75 miles). Volkswagen recommends contacting an authorized Volkswagen dealer or authorized Volkswagen Service Facility.

i If the dimensions of the new tires do not match the dimensions of the tires that have been removed and require a different cold tire pressure, you will need to adapt the tire pressures for the tire pressure monitoring system ⇒ *Function of the Tire Pressure Monitoring System*.

Tire characteristics

Tire labeling and tire classifications



Fig. 192 International tire labeling.

fig. 192 Tire labeling (example), meaning		
①	Product name	Individual manufacturer tire designation.
②	DOT	The tire conforms to the legal requirements of the Department of Transportation in the USA, which is responsible for tire safety standards.

fig. 192 Tire labeling (example), meaning

③	JHCO CHWS 2213	Tire identification number (TIN – may only be on the inner side of the tire) and production date:	
		JHCO CHWS	Code for the factory that produced the tire and specifications from the tire manufacturer for the tire size and tire characteristics.
		2213	Production date: 22nd week in the year 2013.
Information for the end consumer about comparative values for specified base tires (standardized test procedures) ⇒ <i>Customer information</i> :			
④	TREADWEAR 280	Relative service life expectancy for the tire, based on a US-specific standard test. A tire with the specification 280 will wear 2.8 times more slowly than a standard tire with a tread wear value of 100. The tire performance depends on the usage conditions and may differ significantly from the standard values depending on the driving behavior, maintenance, different road conditions, and climate conditions.	
⑤	TRACTION AA	Wet braking capability of the tire (AA, A, B or C). The wet braking capability is measured under controlled conditions on certified test courses. Tires marked with C have low traction performance. The traction value assigned to tires is based on straight-line traction test and includes neither acceleration and cornering, nor hydroplaning and traction under maximum load.	
⑥	TEMPERATURE A	Temperature stability of the tire at high speeds on the test stand (A, B or C). Tires marked with A and B exceed the legal requirements. The temperature rating is based on the tires being inflated to the correct pressure and not overinflated. Excess speed, incorrect tire pressure, and overinflation either alone or in combination can cause heat to build up and cause tire damage.	
⑦	88 H	Load index and speed rating .	
⑧	Rotation and arrow	Tire running direction code .	
	Or: Outside	Code on the outside of the tire .	
⑨	MAX INFLATION 350 KPA (51 psi/3.51 bar)	US limit for the maximum inflation pressure.	
⑩	M+S or M/S or 	Code for tires that can be used in the winter (mud and snow tires) ⇒ <i>Winter tires</i> . Studded tires are marked with an E after the S.	

fig. 192 Tire labeling (example), meaning

11	TWI	Indicates the location of the tread wear indicator ⇒ <i>Monitoring the tread depth.</i>	
12	Brand name, logo	Manufacturer.	
13	Made in Germany	Country of manufacture.	
14	CCC	Country-specific code for China (China Compulsory Certification).	
15	023	Country-specific code for Brazil.	
16	E4 e4 0200477-b	Identification according to international regulations with the number of the country that issued the approval. Approved tires in accordance with ECE regulations are marked with an <i>E</i> . Tires in accordance with EU regulations are marked with an <i>e</i> . The multi-digit approval number follows that.	
17	RADIAL TUBELESS	Tubeless radial tires.	
18	P 195 / 65 R 15 XL	Size designation:	
		P	Code for passenger vehicles.
		195	Tire width from one sidewall to the other in mm.
		65	Height and width ratio in %.
		R	Belt construction code for radial.
		15	Rim diameter in inches.
19	MAX LOAD 615 KG (1235 LBS)	US load capacity for the maximum load per tire.	
□	SIDEWALL 1 PLY RAYON	Specification for the components of the tire body. 1 layer rayon.	
	TREAD 4 PLIES 1 RAYON + 2 STEEL + 1 NYLON	Specification for the components of the running surface. In the example, there are the following 4 layers under the running surface: 1 rayon layer, 2 steel belts, and 1 nylon layer.	

The labeling is on both sides of the tire. In some cases, certain codes may only be on one side of the tire, such as the tire ID number and the production date.

Other digits that may be present are part of the internal labeling from the tire manufacturer or country-specific labeling.

Low-profile tires

Compared to other tire-rim combinations, low-profile tires offer a wider tread surface and a larger rim diameter with shorter tire sidewalls. Low-profile tires improve handling performance and precision. However, they may reduce the level of comfort when

driving on roads in poor condition.

Unidirectional tires

The sidewalls on unidirectional tires are marked with arrows. The specified running direction must be followed. This ensures the optimum running characteristics.

If a tire is mounted opposite from the specified running direction, drive more carefully because the tire is not being used the way it was designed to be used. The tire must be replaced or mounted in the correct running direction as soon as possible.

Asymmetrical tires

Asymmetrical tires factor in the behavior of the inner and outer areas of the tread pattern. The sidewalls on asymmetrical tires are marked as the inner and outer side. Maintain the correct position of the tire on the rim.

Tire load

The tire load index indicates the maximum load of an individual tires in kilograms.

Some examples:

78	425 kg (936 lbs)
81	462 kg (1018 lbs)
83	487 kg (1073 lbs)
85	515 kg (1135 lbs)
87	545 kg (1201 lbs)
88	560 kg (1234 lbs)
91	615 kg (1355 lbs)
92	630 kg (1388 lbs)
93	650 kg (1433 lbs)
95	690 kg (1521 lbs)
97	730 kg (1609 lbs)
99	775 kg (1708 lbs)
100	800 kg (1763 lbs)
101	825 kg (1818 lbs)
102	850 kg (1873 lbs)
103	875 kg (1929 lbs)
104	900 kg (1984 lbs)

Speed rating

The speed rating indicates the maximum speed that may be driven with the tire.

P	max. 150 km/h (93 mph)
Q	max. 160 km/h (99 mph)
R	max. 170 km/h (106 mph)

S	max. 180 km/h (112 mph)
T	max. 190 km/h (118 mph)
U	max. 200 km/h (125 mph)
H	max. 210 km/h (130 mph)
V	max. 240 km/h (149 mph)
W	max. 270 km/h (168 mph)
Y	max. 300 km/h (186 mph)
Z	above 240 km/h (149 mph), depending on manufacturer also ZR

²⁾ The TIN is the tire serial number.

UTQG tire classification

Uniform Tire Quality Grading (UTQG): Quality grades can be found where applicable on the tire sidewall between the tread shoulder and maximum section width. Example:

- Treadwear (number)
- Traction AA, A, B or C
- Temperature A, B or C

For example: Treadwear 200, Traction AA, Temperature A.

All passenger car tires must conform to Federal Safety Requirements in addition to these grades.

Treadwear

The treadwear grade is a comparative rating based on the wear rate of the tire when tested under controlled conditions on a specified government test course.

For example, a tire graded 150 (Treadwear-value 150) would wear one-and-one-half (1 1/2) times as well on the government course as a tire graded 100.

The relative performance of tires depends upon the actual conditions of their use, however, and may depart significantly from the norm due to variations in driving habits, service practices and differences in road characteristics and climate.

Traction

The traction grades, from highest to lowest, are AA, A, B, and C. Those grades represent the tire's ability to stop on wet pavement as measured under controlled conditions on specified government test surfaces of asphalt and concrete. A tire marked C may have poor traction performance.

WARNING

The traction grade assigned to this tire is based on straight-ahead braking traction tests, and does not include acceleration, cornering, hydroplaning, or peak traction characteristics.

Temperature

The temperature grades are A (the highest), B, and C representing the tire's resistance to the generation of heat, and its ability to dissipate heat when tested under controlled conditions on a specified indoor laboratory test wheel.

Sustained high temperature can cause the material of the tire to degenerate and reduce tire life, and excessive temperature can lead to sudden tire failure.

The grade C corresponds to a level of performance which all passenger car tires must meet under the Federal Motor Vehicle Safety Standard No. 109. Grades B and A represent higher levels of performance on the laboratory test wheel than the minimum required by law.

⚠ WARNING

The temperature grade for this tire is established for a tire that is properly inflated and not overloaded. Excessive speed, underinflation, or excessive loading, either separately or in combination, can cause heat buildup and possible tire failure.

Tire load and vehicle load, determining the correct load

Vehicles and tires have a limited load capacity. An overloaded vehicle is difficult to steer and brakes less effectively. Overloading your vehicle can also cause damage to the vehicle and tires, such as tire blowouts and sudden pressure losses.

To ensure your safety and the safety of your passengers, never exceed the maximum vehicle weight. This is specified as the **Gross Vehicle Weight Rating (GVWR)**.

The GVWR includes the weight of your vehicle including all additional equipment, a full fuel tank, all fluids and its maximum load. The maximum load includes the number of people that can travel in the vehicle (number of seats) with an average weight of 150 lbs (68 kg) per person, and also luggage. In trailer mode, the weight of the trailer and the trailer tongue weight rating must be included in calculations.

The **Gross Axle Weight Rating (GAWR)** is the maximum axle load per axle. The GVWR and GAWR are listed on the safety certificate on the B-pillar on the driver's side.

Your vehicle has either 4 (2 front, 2 rear), 5 (2 front, 3 rear), 6 (2 front, 2 center, 2 rear) or 7 (2 front, 3 center, 2 rear) seats, depending on the type of vehicle. Each seat has a safety belt. As there is an upper limit to the GVWR, the maximum load also has an upper limit. Traveling with a full vehicle or with passengers heavier than 150 lbs (68 kg) per person will reduce the remaining possible load.

The tire inflation pressure label for your vehicle also specifies the maximum weight.

Determining the correct tire load

Never overload tires. The following example illustrates how to determine the combined weight of all vehicle occupants and luggage or other vehicle payloads. Never overload the vehicle!

Steps for Determining Correct Load Limit:	
1.	Locate the statement "The combined weight of occupants and cargo should never exceed XXX kg or XXX lbs." on your vehicle's placard.
2.	Determine the combined weight of the driver and passengers that will be riding in your vehicle.
3.	Subtract the combined weight of the driver and passengers from XXX kg or XXX lbs.
4.	The resulting figure equals the available amount of cargo and luggage load capacity. For example, if the "XXX" amount equals 1400 lbs. and there will be five 150 lb passengers in your vehicle, the amount of available cargo and luggage load capacity is 650 lbs. (1400–750 (5 × 150) = 650 lbs.)
5.	Determine the combined weight of luggage and cargo being loaded on the vehicle. That weight may not safely exceed the available cargo and luggage load capacity calculated in Step 4.
6.	If your vehicle will be towing a trailer, load from your trailer will be transferred to your vehicle. Consult this manual to determine how this reduces the available cargo and luggage load capacity of your vehicle.
	Check the tire sidewall to determine the load index specified for the tire.

Exceeding the maximum vehicle weight can cause you to lose control of the vehicle and cause accidents resulting in severe and/or fatal injuries.

- Never exceed the maximum load or the maximum vehicle weight as per the GVWR.

Glossary of tire and load terminology

Accessory weight: The combined weight (in excess of those standard items which may be replaced) of automatic transmission, electro-mechanical power steering, power brakes, power windows, power seats, radio, and heater, to the extent that these items are available as factory-installed equipment (whether installed or not).

Aspect ratio: The ratio of sidewall height to tire width, expressed as a percentage. A number of 50 (0.5:1 or 50%) means that the cross-sectional height is 50% of the tread width. A shorter sidewall can improve steering response and provide better overall handling, for example, on dry pavement.

Bead: The part of a tire made of steel wires, wrapped or reinforced by ply cords, with the shape and structure to ensure proper fit to the wheel rim.

Bead separation: A breakdown of the bond between components in the bead.

Carcass: The tire structure, except tread and sidewall rubber which, when inflated, bears the load.

Chunking: The breaking away of pieces of the tread or sidewall.

Cord: The strands of material forming the plies in the tire.

Cord separation: The parting of cords from adjacent rubber compounds.

Cracking: Any parting within the tread, sidewall, or inner liner of the tire extending to cord material.

Cold tire inflation pressure: The tire pressure recommended by the vehicle manufacturer for a tire of a specified size that has not been driven for more than a couple of miles (kilometers) at low speeds in the 3 hour period before the tire pressure is measured or adjusted.

Curb weight: The weight of a motor vehicle with standard equipment including the maximum capacity of fuel, oil, and coolant air conditioner, and additional weight of optional equipment.

Extra load tire: A tire designed to operate at higher loads and at higher inflation pressures than the corresponding standard tire.

Gross Axle Weight Rating (GAWR): The load-carrying capacity of a single axle system, measured where the tire contacts the ground.

Gross Vehicle Weight Rating (GVWR): The maximum loaded weight of the vehicle.

Groove: The space between 2 adjacent tread ribs.

Load rating code: The maximum load that a tire is rated to carry for a given inflation pressure. You may not find this information on all tires because it is not required by law.

Maximum loaded vehicle weight: The total of:

- Curb weight.
- Accessory weight.
- Vehicle capacity weight.
- Production options weight.

Maximum (permissible) inflation pressure: The maximum cold inflation pressure to which a tire may be inflated. Also called "maximum inflation pressure."

Normal occupant weight: Means 150 lbs (68 kilograms) times the number of occupants seated in the vehicle up to the total seating capacity of your vehicle.

Occupant distribution: The placement of passengers in a vehicle.

Outer diameter: The diameter of a new, properly inflated tire.

Overall width: Total width measured at the exterior sidewalls of an inflated tire, including the additional width of labeling, decorations, or protective bands or ribs.

Passenger car tire: A tire intended for use on passenger cars, multipurpose passenger vehicles, and trucks, that have a gross vehicle weight rating (GVWR) of 10,000 pounds or less.

Ply: A layer of rubber-coated parallel cords.

Ply separation: A parting of rubber compound between adjacent plies.

Pneumatic tire: A mechanical device made of rubber, chemicals, fabric, and steel or other materials, that, when mounted on an automotive wheel, provides the traction and contains the gas or fluid that sustains the load.

Production options weight: The combined weight of installed regular production options weighing over 5 lbs (2.3 kg) more than the standard items they replace, and not previously considered as curb weight or accessory weight. These include, for example, heavy-duty brakes, ride levelers, roof rack, heavy-duty battery, and special trim.

Radial ply tires: A pneumatic tire in which the ply cords that extend to the beads are laid at substantially 90 degrees to the centerline of the tread.

Recommended inflation pressure: The tire pressure recommended by the vehicle manufacturer for a tire of a specified size that has not been driven for more than a couple of miles (kilometers) at low speeds in the 3 hour period before the tire pressure is measured or adjusted.

Reinforced tire: A tire designed to operate at higher loads and at higher inflation pressures than the corresponding standard tire.

Rim: The outer edge of a wheel upon which the tire beads are seated.

Rim diameter: The nominal diameter of the wheel's tire bead seating surface. If you change your wheel size, to wheels of a different diameter, you will have to purchase new tires to match the new wheels.

Rim size: Designation means rim diameter and width.

Rim type designation: The industry or manufacturer's designation for a rim by style or code.

Rim width: The nominal distance between wheel rim flanges.

Section width: The linear distance between the exteriors of the sidewalls of an inflated tire, excluding elevations due to labeling decoration, or protective bands.

Sidewall: The portion of a tire between the bead and the tread.

Sidewall separation: The parting of the rubber compound from the cord material in the sidewall.

Speed rating (letter code): A standardized letter code indicating the maximum speed at which a tire is designed to be driven for extended periods of time. The ratings range from 93 mph (150 km/h) "P" to 186 mph (300 km/h) "Y". The speed rating letter code, where applicable, is molded on the tire sidewall. You may not find this information on all tires because it is not required by law.

Tire Pressure Monitoring System: A system that detects when at least one of a vehicle's tires is underinflated and illuminates a low tire-pressure warning light.

Tread: The portion of a tire that normally touches the road.

Tread rib: A tread section running circumferentially around a tire.

Tread separation: Tire failure caused by the tread pulling away from the tire carcass.

Tread wear indicators (TWI): Raised areas within the main tread grooves that show, visually, when tires are worn and near

the end of their useful life.

Uniform Tire Quality Grading (UTQG): A tire information system developed by the U.S. National Highway Traffic Safety Administration (NHTSA) that is designed to help buyers compare tires. UTQG is not a safety rating, nor is it a guarantee that a tire will last for a certain number of miles or perform a certain way. It gives tire buyers more information to compare with factors such as price, brand loyalty and dealer recommendations. Under UTQG, tires are graded by the tire manufacturers in 3 areas: tread wear, traction and temperature resistance. UTQG information is molded into the tire sidewalls.

U.S. DOT Tire Identification Number (TIN): A tire's serial number. It begins with the letters "DOT" ("Department of Transportation") and indicates that the tire meets all federal standards. The next 2 numbers or letters indicate the plant where the tire was manufactured. The last 4 numbers represent the week and year of manufacture. For example, the numbers 1709 mean that the tire was produced in the 17th week of 2009. Any other numbers are marketing codes used by the tire manufacturer. This information is used to help identify affected consumers if a tire defect requires a recall.

Vehicle capacity weight: The total rated cargo, luggage and passenger load. Passenger load is 150 lbs (68 kilograms) times the vehicle's total seating capacity (as listed on the label inside the driver door).

Vehicle maximum load on the tire: The load on an individual tire that is determined by taking each axle's share of the maximum loaded vehicle weight (GAWR) and dividing by 2.

Vehicle normal load on the tire: The load on an individual tire that is determined by taking each axle's share of the curb weight, accessory weight, and normal occupant weight (distributed according to the table below) and dividing by 2.

Wheel size designation: Wheel rim diameter and width.

Occupant loading and distribution for vehicle normal load for various designated seating capacities:

Designated seating capacity, number of occupants	Vehicle normal load, number of occupants	Occupant distribution in a normally loaded vehicle
2, 3, or 4	2	2 in front
5, 6, or 7	3	2 in front, 1 in back

Maintenance

Service

Information About Service

You can find more information about maintaining your vehicle and the nature and extent of the maintenance on the website:
<https://maintenance.vw.com>

Vehicle care

Vehicle care information

Regular, proper care helps to maintain your vehicle.

The longer dirt remains on the surfaces of vehicle components, the more difficult it may be to clean and care for them. Long-term exposure can make it impossible for dirt to be removed.

For questions regarding care products or for vehicle components that are not listed, consult a suitably qualified professional. Volkswagen recommends contacting an authorized Volkswagen dealer or authorized Volkswagen Service Facility.

Suitably qualified professionals can provide you with suitable accessories. Volkswagen recommends the use of Genuine Volkswagen Accessories, which you can acquire from an authorized Volkswagen dealer or authorized Volkswagen Service Facility. Read and follow the usage instructions on the packaging.

WARNING

Cleaning, impregnating and caring for vehicle components incorrectly can irreparably damage and impair the vehicle's safety equipment, such as the airbag modules. This may cause serious injuries in the event of an accident.

- Always use suitable cleaning agents. More information can be obtained from suitably qualified professionals. Volkswagen recommends contacting an authorized Volkswagen dealer or authorized Volkswagen Service Facility.
- Never use cleaning solutions that contain solvents.
- Clean and maintain vehicle components only according to the manufacturer's instructions.

WARNING

Cleaning the vehicle incorrectly may result in serious injuries.

- Protect your hands and arms against components with sharp edges, for example when cleaning the inside of the wheel housings.
- Always follow the manufacturer's instructions when using cleaning agents.

WARNING

Dirty, foggy, or icy door windows reduce visibility and can impair the vehicle's safety equipment. This can cause accidents and serious or fatal injuries.

- Only drive when there is clear visibility through all windows.
- Do not use water-repellent window solutions on the windshield. This can cause intense glare under poor visual conditions.

WARNING

Care products may be poisonous, highly flammable and corrosive. Using care products incorrectly or using unsuitable care products can cause burns and poisoning and may lead to accidents and serious or fatal injuries.



- Note the package insert.
- Only store care products in their sealed original containers.
- Keep children away from all care products.
- Only use care products outside or in well-ventilated areas so that no harmful vapors are inhaled.
- Never use turpentine, engine oil, fuel, nail polish remover, or other highly volatile fluids for vehicle care.

NOTICE

Cleaning dirt with aggressive and solvent-based products can cause permanent damage to vehicle equipment, for example even with only brief exposure on seat cushions or decorative parts.

- Do not allow dirt to dry.
- Have stubborn spots removed by a suitably qualified, authorized Volkswagen dealer or authorized Volkswagen Service Facility.

Washing the vehicle

 Please read the introductory information and heed the Warnings and Notice  and  *Vehicle care information*. Washing your vehicle regularly prevents exposure to contamination, which may damage the paint.

Matte-finish vehicles require special care due to the particular properties of the paint.

To ensure that your vehicle is washed correctly and appropriately, note the following information  , .

WARNING

After the vehicle has been washed, the braking efficiency may be delayed due to damp or (in the winter) icy brake discs and brake pads. This will increase the braking distance. This can cause a loss of vehicle control, accidents, and serious or fatal injuries.

- Press the brake pedal carefully several times to dry the brakes and clear the ice from them, as long as the visibility, weather, road, and traffic conditions permit.

NOTICE

Improper car washes can increase the risk of severe vehicle damage.

- Always follow the steps described for vehicle care and cleaning.
- Always follow the manufacturer's instructions.
- Do not wash the vehicle in direct sunlight.

NOTICE

Wet vehicle components may freeze in cold weather, which will stop them from working properly.

- In cold weather, never direct a jet of water at locks, doors, or the trunk lid.

Removing stubborn dirt on matte paint

- Soak insects or bird excrement that have adhered to the surface immediately with water and spray with a special cleaner for matte paint.
- Remove tar splashes on the paint surface with commercially available tar removers. Residue must not be removed by intensive rubbing.
- Remove tree resin and rust particles with special cleaner for matte paint and a cleaning clay bar. Slide the cleaning clay bar over the affected areas without pressing down on it.
- Spray grease and fingerprints with a special cleaner for matte paint and rub with a soft microfiber cloth.
- Rinse gasoline residue immediately with plenty of water.

Automatic car washes

NOTICE

Washing the vehicle incorrectly can damage the matte paint surface and destroy the matte paint finish.

- Never use washing programs with wax treatment.
- Only use cleaning agents free of solids and abrasives, such as cleansing shampoos or insect removers, for cleaning purposes.
- Do not use insect sponges or rough sponges.
- If your vehicle has matte paint, never select a wash program with wax or drying aids.
- If your vehicle has matte paint, only use textile car washes, never brush car washes.
- For vehicle with decorative and protective decals, never use a wash package with hot wax.
- Choose car washes without brushes.
- Also ensure that the underside of the vehicle is washed regularly and thoroughly to remove any residue.
- Observe the information provided by the car wash operator, particularly with regard to attachments on the vehicle, e.g. spoilers ⇒ .
- ✓ The windows are closed and the outside mirrors are folded in.
- ✓ The electronic parking brake is switched off.
- ✓ Vehicles with steering lock: If the vehicle is mechanically towed in the car wash, the steering must not be locked ⇒ *Steering information*.
- ✓ Vehicles with an automatic transmission: If the vehicle is mechanically towed toward the car wash, the transmission must be in the neutral position **N**.
- ✓ The windshield wiper ⇒ *Window wipers* and the rain/light sensor ⇒ *Rain/light sensor* are switched off.
- ✓ If applicable: the roof antenna has been removed.

NOTICE

Car washes which mechanically scan contours may damage the vehicle and attachments, e.g. spoiler.

- Follow the information provided by the car wash operator, especially if there are attachments on the vehicle.

- 🍃 Only wash the vehicle in facilities specifically designed for that purpose. This will reduce the risk of water contaminated with oil from entering the sewer system.

Pressure washers



Fig. 193 In the hood space: do not use a pressure washer.

- Never use rotating nozzles. Observe the manufacturer's instructions.
- Only use water up to maximum +60 °C (approximately +140 °F).
- Move the water jet evenly with a distance of at least 50 cm (approximately 20 inches) between the spray nozzle and all parts of the vehicle.
- Do not direct the water at the same spot for a long period of time.
- If possible, do not direct the water straight at sensitive vehicle components, e.g. rubber seals, side windows, glossy trims, tires, sensors, camera lenses, decorative and protective decals.
- Never clean icy or snow-covered door windows with a pressure washer.

! NOTICE

Strong streams of water or vapor could activate the sensors in the door handles if a valid vehicle key is located near the vehicle. This may cause the windows to open and moisture may enter the vehicle interior. This could lead to damage to the vehicle interior.

- Never direct the jet of a high pressure cleaner or a steam jet directly towards the sensors in the door handles.

🔧 If the jet of a pressure washer or a steam jet is directed towards the sensors in the door handles, the vehicle can be unlocked.

Hand washing

Individual contaminations on the paint can be removed with a cleaning clay bar.

1. Clean dust and large dirt deposits from the vehicle with plenty of water.
2. If your vehicle has matte paint, remove insects, grease spots and fingerprints with a special cleaner for matte paint. Apply

the product using a microfiber cloth with gentle pressure.

3. Clean the vehicle with a soft sponge, a washing glove, or a washing brush with light pressure. Start at the roof, and continue to work from the top down. Only use a cleansing shampoo on stubborn dirt.

If your vehicle has matte paint, clean from top to bottom with a neutral cleansing shampoo and a microfiber cloth. Wash the microfiber cloth thoroughly at frequent intervals.

4. Clean the wheels and side members with a clean sponge.
5. Rinse with plenty of water.
6. Let the vehicle air dry.
7. Remove water residue with a leather cloth.

 If the contamination on the paint cannot be removed by hand washing, individual areas of contamination can be removed with a cleaning clay bar.

Exterior care and cleaning

 Please read the introductory information and heed the Warnings and Notice  and  *Vehicle care information*.

NOTICE

Incorrect cleaning and care can cause vehicle damage.

- Always follow the manufacturer's instructions.
- Never use cleaning objects that are too hard or abrasive.

Door windows, glass surfaces

- Remove wax residue, for example from care products, with a suitable glass cleaner or the Volkswagen Genuine cleaning cloth.
- Remove snow with a hand brush.
- Remove ice with a plastic scraper. When doing so, scrape in one direction only.
- Defrost the ice with a suitable deicer or Volkswagen Genuine deicer.
- Clean the wiper blades or, if necessary, replace them.

Paint

Always treat surfaces with extreme care to prevent paint damage.

- Immediately clean any slight contamination, e.g. deposits, insect residues, cosmetics with a clean, soft cloth and mild soap solution of maximum two tablespoons of neutral soap to one liter of water or with cleaning clay.
- Clean spilled fuel or operating materials immediately.
- Dampen rust spots with soap solution. Then remove with a cleaning clay bar.
- Have corrosion removed by suitably qualified professionals. Volkswagen recommends contacting an authorized Volkswagen dealer or authorized Volkswagen Service Facility.
- In the event of paint damage, consult suitably qualified professionals and have the paint damage repaired. Volkswagen recommends contacting an authorized Volkswagen dealer or authorized Volkswagen Service Facility.

A preservation treatment protects the vehicle paint. When water no longer clearly beads up and drips off clean vehicle paint, the vehicle should be retreated with a wax protectant if not earlier.

- For matte paint, apply a special wax for matte paint with a soft sponge to the cleaned vehicle. Remove excess wax with a microfiber cloth.

Polishing is only needed if the appearance of the vehicle paint is poor and a shiny finish can no longer be achieved using protectants.

NOTICE

For matte finishes, the surface will be irreparably damaged if you polish the paint.

- Never polish matte-finish surfaces.

 Even if a wax protectant is applied regularly in an automatic car wash, Volkswagen recommends protecting the vehicle paint at least twice a year with a suitable hard wax or Volkswagen Genuine hard wax.

Plenum chamber, hood space

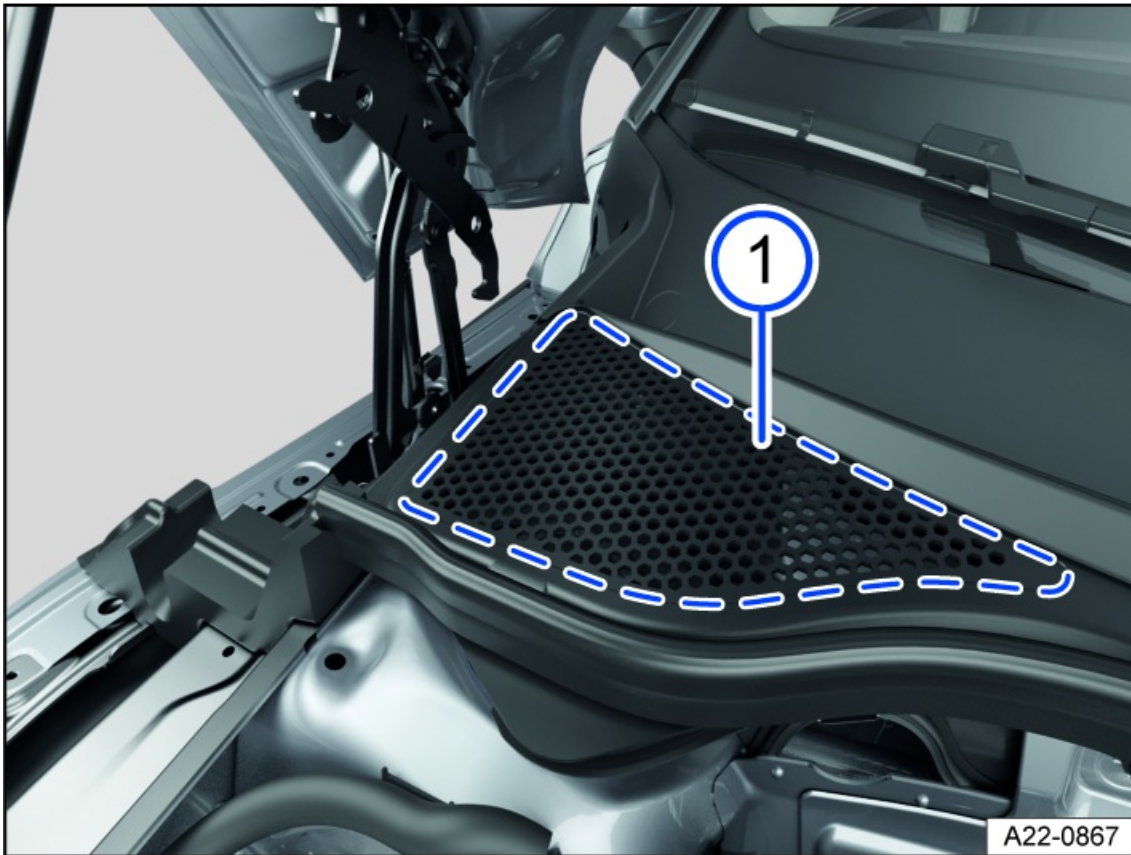

Fig. 194 Between the hood space and windshield: Plenum chamber (general example).

-  Perforated cover of the water box.

WARNING

Working on the engine or in the hood space carries a risk of accidents and fire. Serious injuries may occur.

- Always note the necessary actions and the safety precautions every time before working in the hood space → page , *Safety precautions for working in the hood space* .
- If you are not familiar with this type of work, arrange for it to be done by an authorized Volkswagen dealer or authorized Volkswagen Service Facility. Volkswagen recommends contacting an authorized Volkswagen dealer or authorized Volkswagen Service Facility.

NOTICE

The plenum chamber drain can be blocked by leaves and dirt. Water that cannot drain may leak into the vehicle interior and cause damage.

- Have the area under the perforated cover regularly cleaned by an authorized Volkswagen dealer or authorized Volkswagen Service Facility qualified in this respect *fig. 194*. Volkswagen recommends contacting an authorized Volkswagen dealer or authorized Volkswagen Service Facility.

ⓘ NOTICE

Water introduced manually into the plenum chamber, for example with a pressure washer, can cause considerable vehicle damage.

- Remove leaves or other loose objects on the perforated cover with a vacuum or by hand *fig. 194*.
- Ensure that large amounts of water do not collect in the plenum chamber, for example if you use a pressure washer.
- Always have the hood space cleaned by a qualified professional. Volkswagen recommends contacting an authorized Volkswagen dealer or authorized Volkswagen Service Facility.

Sensors, camera lenses



Fig. 195 In the rear of the vehicle: Rear View Camera system on the handle (general example).

- Clean the area in front of the sensors or the camera with a soft cloth and solvent-free cleaning solution.
- Clean the sensor areas of the rain/light sensor, the camera window on the windshield and the glass surfaces (depending on the vehicle equipment).
- Remove snow with a hand brush.
- Never use warm or hot water.
- Defrost the ice with a suitable deicer or Volkswagen Genuine deicer.

Decorative and protective decals

- Remove contaminants as described for paint. For matte decorative decals, use a suitable plastic cleaner or a Volkswagen Genuine plastic cleaner.
- Treat the vehicle every three months with liquid hard wax. The vehicle must be free of dirt and dust before treating. Apply using only clean, soft microfiber cloths. Do not use hot wax, even in a car wash.
- Remove hard contaminants gently with ethyl alcohol and then wash with warm water.

 For decorative and protective decals, the durability and coloring are influenced by environmental factors, such as solar radiation. Decorative decals may show signs of wear and aging after approximately one to three years, and protective decals after approximately two to three years. In very hot climates, the decorative decals may fade slightly within one year and the protective decals within two years.

Trims made out of chrome-plated plastic, aluminum or stainless steel

- Clean surfaces with a suitable chrome and aluminum product or Volkswagen Genuine chrome and aluminum products.
- Chrome-plated trims can be protected with a suitable hard wax or Volkswagen Genuine hard wax.

Headlights, taillights

- Remove contamination with a soft, damp sponge with a mild soap solution of maximum two tablespoons of neutral soap to one liter of water. Do not use cleaning solutions containing alcohol and/or solvents.
- Remove stubborn dirt with a suitable chrome and aluminum product or Volkswagen Genuine chrome and aluminum products.

Wheels



- Remove contaminants and road salt with plenty of water.
- Clean dirty alloy wheels with a suitable rim cleaner or with Volkswagen Genuine rim cleaner. Volkswagen recommends applying a suitable hard wax or Volkswagen Genuine hard wax to the rims every three months.
- Repair damaged protective paint layers immediately with a paint pen. If necessary, contact an authorized Volkswagen dealer or authorized Volkswagen Service Facility. Volkswagen recommends contacting an authorized Volkswagen dealer or authorized Volkswagen Service Facility.
- Remove brake dust with a suitable rim cleaner or Volkswagen Genuine rim cleaner.

Door lock cylinder

1. Defrost the door lock cylinder with a suitable door lock deicer or Volkswagen Genuine deicer.

Do not use any door lock deicers with degreasing substances.

Care and cleaning of the vehicle interior

 Please read the introductory information and heed the Warnings and Notice  and  *Vehicle care information*. The following overview gives recommendations for cleaning and caring for individual vehicle components.

NOTICE

Incorrect cleaning and care can cause vehicle damage.

- Always follow the steps described for vehicle care and cleaning.
- Do not use steam cleaners, brushes, hard sponges, etc.
- Have tough spots removed by a suitably qualified professional. Volkswagen recommends contacting an authorized Volkswagen dealer or authorized Volkswagen Service Facility.

Door windows

- Clean the door window with a glass cleaner.
- Wipe the door windows dry with a clean chamois or a lint-free cloth.

Textiles, microfiber, leatherette

- Regularly remove dirt particles that adhere to the surface with a vacuum cleaner so that the material is not permanently damaged by scrubbing.
- Remove contaminants with a suitable interior cleaner or Volkswagen Genuine interior cleaner.
- For grease-based contaminants such as oil, use a suitable interior cleaner or Volkswagen Genuine interior cleaner. Blot away the dissolved grease or dye with an absorbent towel. If necessary, treat afterwards with water.
- For contaminants, for example from pens or nail polish, use a suitable interior cleaner or Volkswagen Genuine interior cleaner. If necessary, treat afterward with a mild soap solution of maximum two tablespoons of neutral soap in a liter of water.
- Never use leather cleaners, solvents, floor polish, shoe polish, paint remover, or other similar substances.
- Never use pressure washers, steam cleaners or cooling sprays.

Natural leather

- Remove fresh dirt with a cotton cloth and a mild soap solution of maximum two tablespoons of neutral soap in a liter of water. Do not let any fluids seep into the cracks.
- For contaminants, for example from pens or nail polish, use a suitable leather cleaner or Volkswagen Genuine leather cleaner.
- Treat dried spots with a suitable leather cleaner or with Volkswagen Genuine leather cleaner.
- Remove any fresh spots of grease such as oil with an absorbent cloth.
- Apply leather care to seats regularly and each time you clean. If leaving the vehicle parked for long periods of time, you should cover the leather to protect it from direct sunlight.

Never treat leather with solvents, floor polish, shoe polish, paint remover, or other similar substances.

Plastic parts

- Clean with a soft, damp cloth.
- If a mild soap solution of maximum two tablespoons of neutral soap in a liter of water cannot remove stubborn stains, use a solvent-free plastic cleaner or Volkswagen Genuine plastic cleaner, if necessary.

Trims, decorative trims made out of chrome, aluminum or stainless steel

- Clean using a clean, soft cloth and mild soap solution of maximum two tablespoons of neutral soap in a liter of water, in a dust-free area.
- Treat anodized surfaces with a suitable chrome and aluminum product or Volkswagen Genuine chrome and aluminum products.

Controls

1. Use a soft brush to remove large dirt deposits as well as any dirt that is difficult to reach.
2. Use a clean, soft cloth and a fairly mild soap solution of maximum two tablespoons of neutral soap in a liter of water. Fluid must not enter into the controls.

Displays and screens

Do not clean the instrument cluster display and the Infotainment system screen when they are dry.

1. Switch the Infotainment system off to clean it.
2. Use a suitable clean and soft cleaning cloth or Volkswagen Genuine cleaning cloth with some water, suitable glass cleaner, or an LCD cleaner ⇒ .

For stubborn dirt:

1. Wet and soak dirt with just a little water ⇒ .
2. Carefully remove dirt using a soft, clean cloth.

NOTICE

If the screen is cleaned with incorrect cleaning agents or when dry, it may be darkened, damaged or scratched.

- Only apply gentle pressure.
- Do not use any aggressive cleaners or products which contain solvents.

NOTICE

If the cloth used to clean the screen is too moist, the screen can no longer be operated or switched off.

- Dry the screen and then leave the vehicle locked from the outside for at least two minutes.

Rubber seals

- Clean with a soft, lint-free cloth and plenty of water.
- Treat regularly with a suitable rubber care product or Volkswagen Genuine rubber care product.

Safety belts

1. Unreel the safety belt completely and leave the belt unreeled.
2. Remove large spots of dirt with a soft brush.
3. Clean the safety belt with a mild soap solution of maximum two tablespoons of neutral soap in a liter of water.
4. Let the belt webbing dry completely, then allow the belt to retract.

WARNING

Improper cleaning of the safety belts, their anchors and the automatic safety belt retractors can cause damage and impair their function. This can cause serious or fatal injuries in the event of accidents.

- Never alter the safety belts for cleaning purposes.
- Never use chemical products to clean the safety belts and their components.
- Do not use any corrosive fluids, solvents, or sharp objects.
- Do not allow fluids and objects to enter the safety belt buckle.
- Let the safety belt dry after cleaning before allowing it to retract completely.

Wood trims

Clean with a soft cloth and fairly mild soap solution of maximum two tablespoons of neutral soap in a liter of water.

Cleaning the seat covers

If dye from clothing such as denim stains the seat covers, this is not considered a defect in the vehicle upholstery. If you want to clean the seat covers yourself, be aware that airbag system components and electrical connectors are installed in the seat covers. Incorrect cleaning, impregnation or moisture may damage these components or cause them to malfunction. This may then cause damage elsewhere in the vehicle's electrical system ⇒ .

Depending on the equipment, electrical components and connectors may be installed in the seat surface with seat heating, which can be damaged by incorrect cleaning or handling. This can also result in damage to other areas of the vehicle electrical system.

- Never use pressure washers, steam cleaners or cooling sprays.
- Never soak seat covers.
- Never switch on seat heating to dry the seats.
- Never use impregnation agents.
- Do not use detergent pastes or mild detergent solutions.
- If there is uncertainty, contact suitably qualified professionals for assistance. Volkswagen recommends contacting an authorized Volkswagen dealer or authorized Volkswagen Service Facility.

WARNING

Cleaning, impregnating and caring for vehicle components incorrectly can irreparably damage and impair the vehicle's safety equipment, such as the airbag modules. This may cause serious injuries in the event of an accident.

- Always use suitable cleaning agents. More information can be obtained from suitably qualified professionals. Volkswagen recommends contacting an authorized Volkswagen dealer or authorized Volkswagen Service Facility.
- Never use cleaning solutions that contain solvents.
- Clean and maintain vehicle components only according to the manufacturer's instructions.

 Needless to say, it is easier to see signs of wear and dirt caused by normal usage on bright materials in the vehicle interior. These signs of use are unavoidable and also indicate the unavoidable deterioration caused by normal usage. Please follow the corresponding care instructions.

Accessories, replacement parts, repairs, and modifications

Accessories and replacement parts

Consult an authorized Volkswagen dealer or authorized Volkswagen Service Facility before purchasing Genuine Volkswagen Accessories, replacement parts, or operating equipment, for example if you would like to retrofit the vehicle with Genuine Volkswagen Accessories or if parts need to be replaced. The authorized Volkswagen dealer or authorized Volkswagen Service Facility is aware of legal regulations and factory recommendations for Genuine Volkswagen Accessories, replacement parts, and operating equipment. Volkswagen recommends contacting an authorized Volkswagen dealer or authorized Volkswagen Service Facility.

Volkswagen recommends the use of Volkswagen original parts or Volkswagen original accessories, which you can acquire from an authorized Volkswagen dealer or authorized Volkswagen Service Facility. Volkswagen has verified their reliability, safety, and suitability. A suitably qualified authorized Volkswagen dealer or authorized Volkswagen Service Facility also specializes in correct installation. Volkswagen recommends contacting an authorized Volkswagen dealer or authorized Volkswagen Service Facility.

Products that are not approved by Volkswagen may not have been evaluated by Volkswagen regarding the reliability, safety, and suitability for the vehicle, despite ongoing market observation. Therefore, Volkswagen can also not be responsible in individual cases if approval is given by an officially-recognized technical inspection and control authority or clearance is given

by a government agency.

You must consult a suitably qualified authorized Volkswagen dealer or authorized Volkswagen Service Facility to replace rim/tire combinations. Volkswagen recommends contacting an authorized Volkswagen dealer or authorized Volkswagen Service Facility.

Retrofitted devices that have a direct effect on vehicle control, must have an **e** symbol (the approval symbol for the European Union) and be approved by Volkswagen for the vehicle. Such devices could include a cruise control system or an electronically-controlled damping system.

Additional electrical devices that do not have a direct effect on vehicle control must have a **e** symbol (manufacturer's Declaration of Compliance for the European Union). Such devices could include refrigerators, computers, or ventilators.

WARNING

Using unsuitable replacement parts and accessories may lead to malfunctions in the vehicle. These problems may also occur if work, modifications and repairs are done incorrectly. This could lead to damage to the vehicle and accidents resulting in serious or fatal injuries.

- Only have suitably qualified professionals make repairs or modifications to a vehicle. Authorized Volkswagen dealers and authorized Volkswagen Service Facilities have the required tools, diagnostic devices, repair information, and qualified personnel. Volkswagen recommends contacting an authorized Volkswagen dealer or authorized Volkswagen Service Facility.
- Only install parts on the vehicle whose design and function are identical to the parts installed at the factory.
- Only use rim/tire combinations that are approved by Volkswagen for your vehicle model. More information can be obtained from suitably qualified professionals. Volkswagen recommends contacting an authorized Volkswagen dealer or authorized Volkswagen Service Facility.

WARNING

Objects in the airbag deployment zone may be thrown around the vehicle interior if the airbags deploy. This can cause serious or fatal injuries.

- Never attach or position objects in the airbag deployment zone.

NOTICE

Retrofitting an engine preheating system may cause malfunctions and vehicle damage with certain engines.

- Consult an authorized Volkswagen dealer or authorized Volkswagen Service Facility about retrofitting an engine preheating system. Volkswagen recommends contacting an authorized Volkswagen dealer or authorized Volkswagen Service Facility.

Sensors and Cameras

The sensors or cameras could shift or become damaged as a result of incorrect repairs, structural changes to the vehicle (such as “lowering”), installation of after-market equipment, or changes to the trim panels. This may impair important functions in the driver assistance systems ⇒ .

- When carrying out repairs or modifications, please note the positions of sensors and cameras on the vehicle in the vehicle overview.

Attachments or Modifications around Sensors and Cameras

WARNING

If the area in front of and around sensors and cameras is covered, for example by the improper attachment of license plates, license plate holders with decorative frames, any additional films or paintwork on the sensors or similar, this may impair the functions of the driver assistance systems. The failure of driver assistance systems can result in accidents and serious or fatal injuries.

- Always contact suitably qualified professionals to find out whether it is possible to attach a license plate or license plate holder with a decorative frame to your vehicle. Volkswagen recommends contacting an authorized Volkswagen dealer or authorized Volkswagen Service Facility.
- When attaching, make sure that there is sufficient distance from sensors and cameras.
- Make sure that the license plate or license plate holder with decorative frame is only attached at the designated position.
- Do not stick additional films over or around sensors.

NOTICE

Improper attachment of license plate holders with decorative frame or license plates may damage vehicle components, e.g. wires or sensors.

- Always contact suitably qualified professionals to find out whether it is possible to attach a license plate or license plate holder with a decorative frame to your vehicle. Volkswagen recommends contacting an authorized Volkswagen dealer or authorized Volkswagen Service Facility.

Decorative frames for license plate holders are designed for holding the license plate.

The radar sensor can be installed either below the license plate or behind the VW emblem. The license plate or the VW emblem can influence the view of the radar sensor in the front area. Therefore fit the license plate at an adequate distance from the radar sensor or only operate the vehicle with the original VW emblem or an emblem approved by Volkswagen.

Damage around Sensors and Cameras

WARNING

If the area around sensors and cameras is damaged, for example due to stone chips or collisions when parking, this may impair the functions of the driver assistance systems. The failure of driver assistance systems can result in accidents and serious or fatal injuries.

- If there is damage in the area of the sensors and cameras, have the component replaced by a suitably qualified professional. Volkswagen recommends contacting an authorized Volkswagen dealer or authorized Volkswagen Service Facility.

After components have been replaced, it may be necessary for sensors and cameras to be set and calibrated by an authorized Volkswagen dealer or authorized Volkswagen Service Facility. Volkswagen recommends contacting an authorized Volkswagen dealer or authorized Volkswagen Service Facility.

If the windshield is damaged within the sensors' and camera's range, for example by a stone chip, then the windshield must be replaced. Stone chip repairs can cause malfunctions in the driver assistance system. After the windshield has been replaced, the cameras and sensors must be set and calibrated by suitably qualified professionals. Volkswagen recommends contacting an authorized Volkswagen dealer or authorized Volkswagen Service Facility.

Repairs and technical modifications

Volkswagen guidelines must be followed when performing repairs and technical modifications ⇒ .

Interference with electronic components and their software can cause malfunctions. Because of the way electronic components are interconnected, such malfunctions can also impair systems that are not directly involved. This means that you risk both a substantial reduction in the operational safety of your vehicle and increased wear of vehicle components.

An authorized Volkswagen dealer or authorized Volkswagen Service Facility cannot assume any liability for damage resulting from repairs and technical modifications that were performed incorrectly.

An authorized Volkswagen dealer or authorized Volkswagen Service Facility is not responsible for damage resulting from repairs and technical modifications that were performed incorrectly. Such damages are also not covered by the Volkswagen warranty.

Have all repairs and technical modifications performed by suitably qualified professionals. Volkswagen recommends contacting your authorized Volkswagen dealer or authorized Volkswagen Service Facility for Volkswagen Genuine Parts®.

Volkswagen repair information

Volkswagen service information and official Volkswagen repair information can be purchased.

Customers in Europe, Asia, Australia, Africa, Central and South America:

Contact suitably qualified professionals for assistance. Volkswagen recommends contacting an authorized Volkswagen dealer or authorized Volkswagen Service Facility. Or register with the **erWin** (electronic repair and service information) web portal:

<https://erwin.volkswagen.de>

Customers in North America and Canada:

If you wish to order the printed service information, please contact:

Volkswagen Technical Literature Ordering Center literature.vw.com

You can also register for the **erWin** web portal:

<https://erwin.vw.com>

Diagnostic connection (on-board diagnosis)

In the vehicle interior, there is a diagnostic connection (OBD) to read event memories. Event memories document faults that have occurred and deviations from specified values from the control module ⇒ .

The diagnostic connection (OBD) is located in the footwell on the driver's side on the underside of the instrument panel or next to the hood release lever behind a cover.

Only have the event memory read out and reset by suitably qualified professionals. Additional information about the saved data can be obtained from suitably qualified professionals. Volkswagen recommends contacting an authorized Volkswagen dealer or authorized Volkswagen Service Facility.

After a malfunction is fixed, the information about it will be deleted from the event memory. Other memory content is overwritten continuously.

Vehicles with special modifications and mountings

The attachment and mounting manufacturer should make sure that the applicable environmental laws and regulations are met for the attachments and mountings, especially the EU directive 2000/53/EG about old vehicle and EU directive 2003/11/EG about market introduction restrictions and the use of certain hazardous materials and compounds.

The installation instructions for any retrofitted equipment should be saved by the vehicle owner and provided to the removal facility if the vehicle is scrapped. This ensures that even vehicles with retrofitted equipment will be disposed of in a way that will not harm the environment.

Engine/motor protection

Engine/motor protection can reduce the risk of damage to the vehicle underbody and the oil pan, for example if driving over

curbs, entering driveways, or on unpaved roads.

Have the retrofitting work performed by suitable qualified professionals. Volkswagen recommends contacting an authorized Volkswagen dealer or authorized Volkswagen Service Facility.

Engine/motor protection may not be available in all countries.

WARNING

Repairs and modifications to the vehicle that are performed incorrectly can impair the effectiveness of the driver assistance systems and deploying airbags. This can cause malfunctions and accidents and serious injuries or death.

- Only have suitably qualified professionals make repairs or modifications to a vehicle. Volkswagen recommends contacting an authorized Volkswagen dealer or authorized Volkswagen Service Facility.

WARNING

Repairs and modifications to the vehicle that are performed incorrectly, for example due to the use of unsuitable parts, may cause vehicle damage, accidents, and serious or fatal injuries.

- Only install parts on the vehicle whose design and function are identical to the parts installed at the factory.
- Only use rim/tire combinations that are approved by Volkswagen for your vehicle model. More information can be obtained from suitably qualified professionals. Volkswagen recommends contacting an authorized Volkswagen dealer or authorized Volkswagen Service Facility.
- Only have suitably qualified professionals make repairs or modifications to a vehicle. Volkswagen recommends contacting an authorized Volkswagen dealer or authorized Volkswagen Service Facility.
- Volkswagen recommends the use of Volkswagen original parts or Volkswagen original accessories. Volkswagen has verified their reliability, safety, and suitability.

WARNING

Incorrect use of the diagnostic connection may cause malfunctions, resulting in accidents and serious or fatal injuries.

- Never read out the event memory yourself using the diagnostic connection.
- Never load data yourself using the diagnostic connection in the vehicle.
- Only have the event memory read out with the diagnostic connection by suitably qualified professionals. Volkswagen recommends contacting an authorized Volkswagen dealer or authorized Volkswagen Service Facility.

Airbag system repairs and situations that can affect the system function

Volkswagen guidelines must be followed when performing repairs and technical modifications ⇒ .

Only have modifications and repairs on the front bumper, doors, front seats, headliner, or vehicle body performed by an authorized Volkswagen dealer or authorized Volkswagen Service Facility. Volkswagen recommends contacting an authorized Volkswagen dealer or authorized Volkswagen Service Facility. Airbag system components and sensors may be located on these vehicle components.

Airbag system components can be damaged during all procedures on the airbag system and when removing and installing system components while performing other repair procedures. This may prevent the airbags from deploying or cause them to deploy incorrectly in the event of an accident.

The instructions must be followed so that the effectiveness of the airbags is not impaired and removed components do not cause injuries and environmental pollution. An authorized Volkswagen dealer or authorized Volkswagen Service Facility will

be familiar with these provisions. Volkswagen recommends contacting an authorized Volkswagen dealer or authorized Volkswagen Service Facility.

A modification to the vehicle suspension can impair the functionality of the airbag system during a collision. For example, using a rim/tire combination that is not approved by Volkswagen, lowering the vehicle, or changing the suspension stiffness including the springs, suspensions struts, shock absorbers, etc., can change the force that is measured by the airbag sensors and transmitted to the electronic control module. For example, some changes to the suspension can increase the force measured by the systems and trigger the airbag system in accidents where the airbags would normally not be deployed if the modifications had not been made. Other modifications can reduce the force measured by the sensors and prevent the airbag from deploying when it should have deployed.

WARNING

Using unsuitable replacement parts and accessories may cause damage and malfunctions in the vehicle and impair the effectiveness of the airbag system. These problems may also occur if work, modifications and repairs are done incorrectly. This could lead to damage to the vehicle and accidents resulting in serious or fatal injuries.

- Only have suitably qualified professionals make repairs or modifications to a vehicle. Authorized Volkswagen dealers and authorized Volkswagen Service Facilities have the required tools, diagnostic devices, repair information, and qualified personnel. Volkswagen recommends contacting an authorized Volkswagen dealer or authorized Volkswagen Service Facility.
- Note that the airbag module cannot be repaired but must instead be replaced.
- Never install airbag components removed from old vehicles or from recycling.
- Only install parts on the vehicle whose design and function are identical to the parts installed at the factory.

WARNING

Modifications to the vehicle suspension including using a rim/tire combination that is not permitted may change the functionality of the airbag. This can cause serious or fatal injuries in the event of an accident.

- Never install suspension components that do not have the same properties as the original parts installed in the vehicle.
- Only use rim/tire combinations that are approved by Volkswagen for your vehicle model. More information can be obtained from suitably qualified professionals. Volkswagen recommends contacting an authorized Volkswagen dealer or authorized Volkswagen Service Facility.

Mobile phone usage in the vehicle

Electromagnetic waves

When using a mobile phone or radio equipment without connecting to the exterior antenna, the electromagnetic waves will not be deflected outward in an optimum way. Increased waves in the vehicle interior can occur, especially when reception is poor, for example in rural areas. This could be a potential health risk ⇒ .

Depending on the equipment, it may be possible to use a suitable telephone interface to connect the mobile phone to the exterior antenna. This will improve the connection quality and increase the range.

Using a phone

In many countries, using a phone in the vehicle is only permitted if there is a hands-free connection, for example using a Bluetooth® connection. Before using the phone, secure it in a suitable holder ⇒  or store it in a storage compartment, such as in the center console, to prevent it from sliding around.

Radio

If operating radio devices, follow the legal regulations and the user guide from the manufacturer. The aftermarket installation of radio devices is subject to approval.

Contact qualified professionals for more information about installing radio equipment. Volkswagen recommends contacting an authorized Volkswagen dealer or authorized Volkswagen Service Facility.

WARNING

Mobile devices that are loose or not secured correctly can be thrown through the vehicle interior during sudden driving or braking maneuvers or in the event of a collision and cause severe injuries.

- Secure or store the mobile phone and accessories safely and outside of the deployment range of the airbags.

WARNING

Using a cell phone or radio equipment without a connection to an external aerial may create electromagnetic energy inside the vehicle that exceeds permissible limits. This also applies if the exterior antenna is not installed correctly. This may be dangerous to your health and that of the other vehicle occupants.

- Maintain a minimum distance of approx. 20 cm (approx. 8 inches) between the device antennae and any active medical implants, such as pacemakers.
- Do not carry a mobile device that is turned on directly above or in the immediate vicinity of any active medical implants, for example by keeping a phone in a shirt pocket.
- Switch off the mobile device immediately if you suspect there is interference with an active medical implant or other medical device.

Customer information

Warranty

Warranty information

Your vehicle is covered by various warranties:

- New Vehicle Limited Warranty.
- Limited Warranty Against Corrosion Perforation.
- Emissions Control System Warranties: Federal Emissions Control System Defect Warranty, Federal Emissions Performance Warranty.
- US battery electric vehicles: High-Voltage System Limited Warranty.
- US models: Kansas Safety Belt Limited Warranty.
- US models: California Emissions Control System Warranties: Short-term Emissions Defects Warranty, Long-term Emissions Defect Warranty, California Emissions Performance Warranty.

You can find detailed information on the website:

<https://maintenance.vw.com>

Reporting Safety Defects

If you believe that your vehicle has a defect which could cause a crash or could cause injury or death, you should immediately inform the National Highway Traffic Safety Administration (NHTSA) in addition to notifying Volkswagen of America, Inc.

If NHTSA receives similar complaints, it may open an investigation, and if it finds that a safety defect exists in a group of vehicles, it may order a recall and remedy campaign. However, NHTSA cannot become involved in individual problems between you, your dealer, or Volkswagen of America, Inc.

To contact NHTSA, you may call the Vehicle Safety Hotline toll-free at:

Tel.: 1-888-327-4236 (TTY: 1-800-424-9153)

go to:

<http://www.nhtsa.gov>

or write to:

Administrator, NHTSA, 1200 New Jersey Avenue, SE. Washington, D.C. 20590

You can also obtain other information about motor vehicle safety from

<http://www.safercar.gov>

Data Memory

Data processing in the vehicle

Electronic control modules are installed in your vehicle. Control modules process data, such as data received by vehicle sensors, self-generated data, or data exchanged between control modules. Some control modules are required to ensure the safe operation of your vehicle. Other control modules assist you while driving (driver assistance systems), and others provide convenience functions or additional Infotainment system functions.

Operational data in the vehicle

Control modules process assigned data necessary for the vehicle operation.

Amongst other, this includes:

- Vehicle status information, e.g. movement delay, deactivation times of speed warning function, safety belt wearing

display.

- Environmental conditions, such as temperature, data from sensors for Adaptive Cruise Control (ACC).
- Image recordings, e.g. data from camera-assisted driver assistance systems.

Generally, recordings and other data intended for specific purposes are temporary, are only processed within the vehicle and are not stored.

However, in addition, control modules can contain a data memory to temporarily or permanently record information about vehicle status, component load, maintenance needs, technical incidents, and malfunctions.

The following information may be stored, depending on vehicle equipment:

- Operating conditions of system components, such as fluid levels, tire pressures, and vehicle battery status.
- Malfunctions and faults in important system components, such as lights and brakes.
- System reactions in special driving situations, such as airbag deployment and interventions by driver assistance systems.
- Information about incidents that cause damage to the vehicle.

In some cases, like if the vehicle detected a malfunction, it may be necessary to store data that would otherwise be temporary.

If you utilize services such as repair or maintenance services, the stored operational data associated with the VIN ⇒ *Vehicle Identification Number (VIN)* may be read out and used if necessary. Employees in the service network, such as employees at authorized Volkswagen dealers or authorized Volkswagen Service Facilities or at third party companies like roadside assistance services, can read out data from the vehicle. The same applies for warranty cases and quality assurance measures.

The data is read out using the OBD (on-board diagnosis) connection that is legally required to be in the vehicle. The operational data that is read out documents the technical status of the vehicle or individual components and assists with vehicle diagnosis, with meeting warranty requirements, and with quality improvement. This data, particularly information about wear and tear of components, technical incidents, operating errors, and other malfunctions, is transmitted together with the VIN to Volkswagen if appropriate. In addition, Volkswagen may use this data for reasons of product liability and product safety such as for recalls. This data can also be used to verify customer claims concerning warranties and guarantees.

The event memory in the vehicle can be reset by an authorized Volkswagen dealer or authorized Volkswagen Service Facility during a repair or service procedure, or by request.

Event data recorder (EDR)

This vehicle is equipped with an event data recorder (EDR). The main purpose of an EDR is to record, in certain crash or near crash-like situations, such as an air bag deployment or hitting a road obstacle, data that will assist in understanding how a vehicle's systems performed. The EDR is designed to record data related to vehicle dynamics and safety systems for a short period of time, typically 30 seconds or less. The EDR in this vehicle is designed to record such data as:

- How various systems in your vehicle were operating;
- Whether or not the driver and passenger safety belts were buckled/fastened;
- How far (if at all) the driver was depressing the accelerator and/or brake pedal; and,
- How fast the vehicle was traveling.

These data can help provide a better understanding of the circumstances in which crashes and injuries occur.

In addition, data from the driver assistance systems is also collected. In addition to information about whether these systems were switched on or off, had limited availability, or were inactive, it can also be understood if these functions steered, accelerated, or braked the vehicle in the situations listed above. Depending on the vehicle equipment, systems may include:

- Adaptive Cruise Control (ACC).

- Lane Assist
- Park Assist.
- Parking systems
- Automatic Emergency Braking Function (Front Assist)

NOTE: EDR data are recorded by your vehicle only if a non-trivial crash situation occurs; no data are recorded by the EDR under normal driving conditions and no personal data (e.g., name, gender, age, and crash location) are recorded. However, other parties, such as law enforcement, could combine the EDR data with the type of personally identifying data routinely acquired during a crash investigation.

To read data recorded by an EDR, special equipment is required, and access to the vehicle or the EDR is needed. In addition to the vehicle manufacturer, other parties, such as law enforcement, that have the special equipment, can read the information if they have access to the vehicle or the EDR.

Volkswagen will not access, read or process the event data recorder (EDR) data unless the vehicle owner gives permission. This excludes contractual or legal regulations.

Due to the legal obligation to monitor products, Volkswagen is allowed to use data for field observation as well as for research purposes and quality improvement of vehicle safety systems. For research purposes, Volkswagen provides the data to third parties in an anonymous format. This means the data does not reference the individual vehicle or the vehicle owner.

Infotainment system and aerials

The aerials for the Infotainment system are fitted in various places in the vehicle:

- On the inside of the rear window.
- On the inside of the rear side windows
- On the inside of the windshield
- On the roof of the vehicle

Antennas on the inside of the door windows can be detected as thin conductors.

ⓘ NOTICE

Antennas that are located on the inside of the window glass can be damaged by abrasive objects or by corrosive and acidic materials.

- Never apply stickers over metal conductors, for example on the rear window.
- Never clean the antennas with corrosive or acidic materials.

ⓘ NOTICE

A retrofitted Infotainment system that is incompatible with the antenna amplifier installed in the vehicle by the manufacturer may damage the antenna amplifier.

- Before retrofitting an Infotainment system, contact an authorized Volkswagen dealer or authorized Volkswagen Service Facility. Volkswagen recommends contacting an authorized Volkswagen dealer or authorized Volkswagen Service Facility.

Component protection

Some electronic components and

control modules, such as the Infotainment system, are equipped with component protection at the factory.

The component protection allows suitably qualified professionals to legitimately install or replace components and control modules. Volkswagen recommends contacting your Volkswagen dealership.

In the following situations, component protection reduces the risk of components supplied by the factory being operated without restrictions outside the vehicle.

- Installation in other vehicles, for example the components have been stolen
- Operating components outside of the vehicle

If a message about component protection appears in the instrument cluster display or on the Infotainment system screen, contact a suitably qualified professional for assistance. Volkswagen recommends contacting your Volkswagen dealership.

Design patent protection

Some vehicle parts may be protected by an American design patent. You can find further detailed information on the website <https://vw.com/patents>

Third Party Copyright Information

Open Source

Some products installed in this vehicle contain software components that are covered under Open Source licenses.

A list of the Open Source software components being used, including copyright information, the relevant Open Source license conditions, and those applicable license texts, are available at the website given below. The source code of specific Open Source software components can be requested from the vehicle manufacturer. The manufacturer will provide the source code in accordance with the relevant license conditions, whereby you will only be charged for the provision costs, e.g. delivery costs. You can obtain the necessary information on the website

<https://www.volkswagen.com/softwareinfo>

Labels and signs

Factory installed labels and plates with important information regarding vehicle operation are located in the engine compartment and on several vehicle components.

- Never remove these labels and signs or make them illegible.
- If vehicle components equipped with labels and signs are replaced, suitably qualified professionals must place identical labels and signs correctly in the same locations on the new components. Volkswagen recommends contacting an authorized Volkswagen dealer or authorized Volkswagen Service Facility.

Safety certificate

A safety certificate on the driver's door jamb specifies all necessary safety standards and guidelines of the traffic safety authorities in the applicable country at the time of manufacture. The month and year of production as well as the VIN may also be listed. Read the information in the Owner's Manual.

WARNING

Removing labels and signs reduces the amount of information about potential hazards and may cause reduced vigilance when working on the vehicle. This can cause serious or fatal injuries.

- Never remove these labels and signs or make them illegible.
- Follow the legal regulations.
- Follow the Owner's Manual instructions.

⚠ NOTICE

Removing labels and signs increases the risk of operating errors and can cause damage to the vehicle.

- Never remove these labels and signs or make them illegible.
- Follow the legal regulations.
- Perform service according to the specifications.

Fluids in the air conditioning system

Refrigerant in the air conditioning system

The label in the hood space provides information about the type and amount of refrigerant used in the vehicle air conditioner. The label is in the front section of the hood space near the refrigerant filler tubes ⇒ ⚠.

Refrigerant oil in the air conditioner

The air conditioner is filled with refrigerant oil. For information about the type and volume of refrigerant oil used, contact a suitably qualified professional. Volkswagen recommends contacting an authorized Volkswagen dealer or authorized Volkswagen Service Facility.

⚠ Warning: maintenance of the air conditioner requires qualified personnel. ⚙ Refrigerant type. ⚙ Type of refrigerant oil. 📖 See service information (only available for authorized Volkswagen dealers and authorized Volkswagen Service Facilities). 👤 Maintenance of the air conditioner requires qualified personnel. 🔥 Flammable refrigerant. 🗑 Make sure all components are disposed of correctly and never install components removed from old vehicles or from recycling in the vehicle.

⚠ DANGER

Maintenance of the air conditioner by unqualified qualified personnel can cause serious and fatal injuries.

- To maintain the air conditioner, contact qualified personnel who have been trained according to the SAE standard J2845 and certified according to the SAE standard J2911. SAE standard J639 must be complied with while performing work on the air conditioner.

⚠ DANGER

The refrigerant is flammable and may cause serious or fatal injuries if maintenance is carried out incorrectly.

- Have the air conditioner serviced by suitably qualified professionals.
- Keep the vehicle away from naked flames, sparks and other ignition sources.

⚠ DANGER

The refrigerant is under pressure and may explode if heated. This may cause serious or fatal injuries.

- Have the air conditioner serviced by suitably qualified professionals.
- Keep the vehicle away from naked flames, sparks and other ignition sources.

DANGER

The refrigerant may form toxic fumes if it comes into contact with hot surfaces. Inhaling them may cause poisoning or even death.

- Have the air conditioner serviced by suitably qualified professionals.



NOTICE

Repairing or replacing the evaporator with replacement parts from scrap vehicles or recycled parts may damage the air conditioner.

- Never have repairs to the evaporator carried out with replacement parts from scrap vehicles or recycled parts.
- Only have replacement parts for the air conditioner evaporator fitted that are certified and marked in accordance with SAE standards J2842 HFO-1234yf and R744.
- Have the air conditioner serviced by suitably qualified professionals who have been trained according to the SAE standard J2845 and certified according to the SAE standard J2911. SAE standard J639 must be complied with while performing work on the air conditioner.
- Have damaged or missing refrigerant labels, e.g. in the hood space, replaced.

Product recycling

Disposal of Old Batteries

As with electronic devices, old batteries must be collected and recycled separately by the end user. These batteries are indicated by the crossed-out wheeled garbage can symbol . You, as the end user, are legally obliged to return old batteries ⇒ .

- In many federal states, old batteries can be handed in to an authorized Volkswagen dealer or authorized Volkswagen Service Facility.
- You can obtain more information on return and recycling from your authorized Volkswagen dealer or authorized Volkswagen Service Facility, or at:

<https://www.volkswagen.com>

Disposal of Old Electric/Electronic Devices

Your vehicle contains electric/electronic devices, such as remote controls. You can recognize these from the symbol of the crossed-out wheeled garbage can .

Old devices with this marking must be collected separately from normal household garbage and disposed of in accordance with legal requirements.

- Batteries within devices that are not permanently installed must be removed beforehand and disposed of separately as batteries.
- Any saved personal data must be erased before disposal of old devices.

You can obtain more information on return and recycling from your authorized Volkswagen dealer or authorized Volkswagen Service Facility.

WARNING

If batteries containing lithium are damaged, gaseous or liquid substances may escape, posing a significant risk to health

and the environment. A short circuit at the battery terminal may result in a fire or explosion. This could result in serious or fatal injuries.

- Take extreme care when handling batteries containing lithium.
- Never heat up lithium-containing batteries.
- Never damage lithium-containing batteries.
- Never short circuit the battery terminals.

 Batteries containing heavy metals are marked with the chemical symbols Hg (mercury), Cd (cadmium) and/or Pb (lead). Heavy metals can be harmful to the health of humans and animals and accumulate in the environment.

- In order to avoid these consequences, it is imperative to ensure you collect batteries separately and return them properly.

 Batteries for the remote control vehicle key and remote controls may contain perchlorate. For information on how to handle these materials correctly, see the following website: www.dtsc.ca.gov/perchlorate. Follow all the legal specifications for dealing with and disposing of these batteries. Volkswagen recommends having these batteries replaced and disposed of by suitably qualified professionals. Volkswagen recommends contacting an authorized Volkswagen dealer or authorized Volkswagen Service Facility.

Old vehicle return and scrap disposal

Old vehicle return

At the end of its life cycle, your vehicle should be recycled or disposed of in an environmentally friendly manner. This is why the last owners of vehicles in many states are legally obliged to hand their vehicles over to an authorized treatment facility.

Volkswagen has already made provision for this point: Recycling centers where you can hand over your vehicle are available throughout many federal states.

Find out more information about recycling centers from your authorized Volkswagen dealer or authorized Volkswagen Service Facility.

Scrap disposal

If scrapping the vehicle or its individual parts such as the airbag system and the safety belt pretensioners, the applicable safety regulations must always be followed. Suitably qualified professionals will be familiar with these provisions. Volkswagen recommends contacting an authorized Volkswagen dealer or authorized Volkswagen Service Facility.

Declarations of Conformity

Declaration of conformity

Placing Finished Products on the British Market (England, Wales, and Scotland):



UKCA marking (UK Conformity Assessed) is a new British product marking used for products being placed on the market in Great Britain (England, Wales, and Scotland).

British regulations for product safety and metrology

Various devices are installed in this vehicle that are subject to UKCA product regulations. The importer of these devices for the British market in the United Kingdom as per the product safety and metrology regulations for the sections below is:

Volkswagen Group United Kingdom Ltd. Yeomans Drive, Blakelands Milton Keynes, MK14 5AN United Kingdom

Declaration of conformity for radio equipment for the USA

FC Approval mark for radio systems in the USA.

With this document, the manufacturer declares that the radio equipment listed in the following is in compliance with the basic requirements and other relevant regulations and laws at the time of production:

These devices meet the requirements of:

FCC Section 15.19

These devices comply with **Section 15 of the FCC requirements**. Operation is subject to the following two requirements:

- (1) This device must not cause any harmful interference and
- (2) this device must accept all received faults, including interference that could lead to unwanted operations.

FCC Section 15.21

CAUTION:

Changes or modifications that have not been expressly approved by the authority responsible for compliance with the regulations may result in revocation of the user's authorization to operate the device.

The radio systems listed below are not available in every vehicle.

With this document, the manufacturer declares that the radio equipment listed in the following is in compliance with the basic requirements and other relevant regulations and laws at the time of production:



The following radio systems are not available in every market or every vehicle.

- Connection to the outside antenna
- Antenna
- Antenna amplifier
- Bluetooth.
- Remote control key (vehicle)
- Digital instrument cluster
- Infotainment system.
- Wireless charging function
- Keyless Access.
- Instrument cluster, electronic immobilizer

- Radar sensors for assistance systems
- Tire pressure sensors
- Control modules with an integrated eSIM card.
- Phone interface
- Volkswagen Car-Net control module
- Wi-Fi hotspot.
- Central control module
- NFC digital key card.
- USB charging connector.

For more information, please visit: www.volkswagen.com/generalinfo.

EU-related documents, e.g. for Ghana, can be found on the website under the EU English button.

 Radio systems with this marking must be collected separately from normal household garbage and disposed of in accordance with legal requirements. You can hand these in at local disposal facilities or nationally commissioned return systems if applicable ⇒ [Product recycling](#).  Symbol for limited use of certain hazardous substances in electrical and electronic devices in accordance with the RoHS directive.

Notes on radio regulations

Certificates and label

Approval numbers

FCC ID: 2AAJCBR20, FCC ID: 2AAJCBR21, FCC ID: 2AAJCBR22, FCC ID: 2AA98, FCC ID: 2AA98-COLOUR5C, FCC ID: 2AA98-MEDIUM5C, FCC ID: 2AA98-MEDIUM5C21, FCC ID: 2AA98A, FCC ID: 2AHPN-WLC, FCC ID: 2AOUZ17101001, FCC ID: 2AOUZ17101002, FCC ID: 2AOUZ17101010, FCC ID: 2AOUZ17101022, FCC ID: 2AOUZ17101023, FCC ID: 2AOUZ17101031, FCC ID: 2AOUZ17101032, FCC ID: 2AOUZ17101033, FCC ID: 2AOUZ17101034, FCC ID: 2AOUZ17101041, FCC ID: 2AOUZ17101042, FCC ID: 2AOUZ17101043, FCC ID: 2AOUZ17101051, FCC ID: 2AOUZ17101052, FCC ID: 2AOUZ17101053, FCC ID: 2AOUZ17101054, FCC ID: 2AOUZ17101055, FCC ID: 2AOUZ17101056, FCC ID: 2AOUZ17101057, FCC ID: 2AOUZ17101071, FCC ID: 2AOUZ17101072, FCC ID: 2AOUZ18020531, FCC ID: 2AOUZ18020532, FCC ID: 2AOUZ18020533, FCC ID: 2AOUZ18020534, FCC ID: 2AOUZ18100931, FCC ID: 2APOM-MQBA0, FCC ID: 2AVXWWSBRC001, FCC ID: 2AXPS-WPC003-1, FCC ID: 772C-LB1FD, FCC ID: BEJLCW05-VWE5, FCC ID: BEJMIB2, FCC ID: BEJMIB2PQ, FCC ID: BEJ-MEBICAS3, FCC ID: BEJ-MIBPQMIN, FCC ID: BEJ-MIB3O1, FCC ID: BEJTLAHW3IU-E, FCC ID: BEJTLAHW3IU-N, FCC ID: BEJTLVHE4IU-E, FCC ID: BEJTLVHE4IU-N, FCC ID: BEJTLVHM3IU-E, FCC ID: BEJTLVHW3IU-E, FCC ID: BEJTLVHM3IU-N, FCC ID: BEJTLVM3IU-N, FCC ID: BEJTUVM01IU, FCC ID: CWTUGZZF1, FCC ID: CWTUGZZF2, FCC ID: IYZVK2, FCC ID: KR5-BCMEVOC, FCC ID: KR5FS14T, FCC ID: KR5FS14TK, FCC ID: KR55NA920791A, FCC ID: LTQR3TR, FCC ID: NBG010180T, FCC ID: NBG010905A, FCC ID: NBG011719A, FCC ID: NBG013854, FCC ID: NBG01RS4, FCC ID: NBG011719A, FCC ID: NBG10176, FCC ID: NBG9068, FCC ID: NBG92596263, FCC ID: NBGBCMEVO, FCC ID: NBGBCMEVO5, FCC ID: NBGBCM2R, FCC ID: NBGFS09P03, FCC ID: NBGFS12A, FCC ID: NBGFS12A01, FCC ID: NBGFS12P, FCC ID: NBGFS12P01, FCC ID: NBGFS12PM, FCC ID: NBGFS12P01M, FCC ID: NBGFS125C, FCC ID: NBGFS125C1, FCC ID: NBGFS125C5, FCC ID: NBGFS173NP, FCC ID: NBGFS173NPM, FCC ID: NBGFS173NR, FCC ID: NBGFS1744M, FCC ID: NBGFS19, FCC ID: NBGFS191, FCC ID: NBGFS93N, FCC ID: NBGMQBBB, FCC ID: NBGMQBBH, FCC ID: NBGPQ12P01, FCC ID: NBGRSB19, FCC ID: NF3-FR5CPEC, FCC ID: NF3-LRR3SCU, FCC ID: NF3-LRR4, FCC ID: NF3-MRR1PLUS, FCC ID: NF3-MRR1REAR, FCC ID: NF3-MRREVO14F, FCC ID: NF3-LRR3SCU, FCC ID: NT8-FPK8IMMO5D, FCC ID: NT8-VWMIBREGIO, FCC ID: NZLADHL5D, FCC ID: NZLJCIBUSHL4, FCC ID: OAYARS4B, FCC ID: OAYARS5B, FCC ID: OYGTSSRE4UD, FCC ID: OYGTSSRE4UF, FCC ID: OYGTSSSG4G5, FCC ID: QIPALAS6A-US, FCC ID: QISME919BS-567BN, FCC ID: QISME919BS-567BNB, FCC ID: QZ9-KA3, FCC ID: RK7MBC-NAR, FCC ID: RK7MBC-NAR2, FCC ID: RK7185-00, FCC ID: RK7186-00, FCC ID: RX2BNFHL, FCC ID: RX2BNFLL, FCC ID: T8GA270, FCC ID: T8GA475, FCC ID: T8GA476, FCC ID: T8GP114, FCC ID: VPYLB1KD, FCC ID: WJLHT-5, FCC ID: NF3-FR5CUEC, FCC ID: NBG01RS55, FCC ID: NF3-F5CP42, FCC ID: NBG01RS53, FCC ID: NBGFS125C1, FCC ID: BEJ-MIB3OIVR-E, FCC ID: BEJTLVHM3IU-N, FCC ID: 2AXPS-WPC003-1, FCC ID: 2AXPS-WPC003-5, FCC ID: 2ACC7DDAECE02, FCC ID: BEJTLVUM3IU-W, FCC ID: BEJTLVUW3IU-W, FCC ID: BEJTLVUM3IU-E, FCC ID: BEJTLVUW3IU-N, FCC ID: BEJTLVUM3IU-N, FCC ID: NT8-FPK815DTR2, FCC ID: NBGFS1901S, FCC ID: NBGFS19S, FCC ID: BEJ-ICAS3GP, FCC ID: NBGFS191S, FCC ID: BEJTLVLM3IU-N, FCC ID: BEJTLVUW3IU-W, FCC ID: BEJTLVUW3IU-N, FCC ID: BEJTLVUM3IU-W, FCC ID: BEJTLVUM3IU-N, FCC ID: BEJTLVUM3IU-E, FCC ID: BEJTLVUE4IU-E, FCC ID: BEJTLVUE4IU-N, FCC ID: BEJTLVUE4IU-W, FCC ID: QZ9-DCB, FCC ID: 2BAHD-EC30693.

Interference Statement

This device complies with part 15 of the FCC Rules. Operation is subject to the following two conditions:

- (1) This device may not cause harmful interference, and
- (2) This device must accept any interference received, including interference that may cause undesired operation.

CAUTION TO USERS: Changes or modifications not expressly approved by the party responsible for compliance could void the user's authority to operate the equipment.

FCC RF Exposure Statement

FCC ID: RK7MBC-NAR

This equipment complies with FCC radiation exposure limits set forth for an uncontrolled environment. End users must follow the specific operating instruction for satisfying RF exposure compliance. This transmitter must not be co-located or operating in conjunction with any other antenna or transmitter.

This is a CONSUMER device.

BEFORE USE, you MUST REGISTER THIS DEVICE with your wireless provider and have provider's consent. Most wireless providers consent to the use of signal boosters. Some providers may not consent to the use of this device on their network. If you are unsure, contact your provider.

You MUST operate this device with approved antennas and cables as specified by the manufacturer. Antennas MUST be installed at least 20 cm (8 inches) from any person.

You MUST cease operating this device immediately if requested by FCC or a licensed wireless service provider.

WARNING: E911 location information may not be provided or may be inaccurate for calls served by using this device.

Wireless Notice

This device complies with FCC radiation exposure limits set forth for an uncontrolled environment and meets the FCC radio frequency (RF) Exposure Guidelines. This transmitter must not be colocated or operating in conjunction with any other antenna or transmitter.

FCC Class A digital device notice

NOTE: This equipment has been tested and found to comply with the limits for a Class A digital device, pursuant to part 15 of the FCC Rules. These limits are designed to provide reasonable protection against harmful interference when the equipment is operated in a commercial environment. This equipment generates, uses, and can radiate radio frequency energy and, if not installed and used in accordance with the instruction manual, may cause harmful interference to radio communications. Operation of this equipment in a residential area is likely to cause harmful interference in which case the user will be required to correct the interference at his own expense.

FCC Class B digital device notice

NOTE: This equipment has been tested and found to comply with the limits for a Class B digital device, pursuant to Part 15 of the FCC Rules. These limits are designed to provide reasonable protection against harmful interference in a residential installation. This equipment generates, uses and can radiate radio frequency energy and, if not installed and used in accordance with the instructions, may cause harmful interference to radio communications. However, there is no guarantee that interference will not occur in a particular installation. If this equipment does cause harmful interference to radio or television reception, which can be determined by turning the equipment off and on, the user is encouraged to try to correct the interference by one or more of the following measures:

- Reorient or relocate the receiving antenna.
- Increase the separation between the equipment and receiver.
- Connect the equipment into an outlet on a circuit different from that to which the receiver is connected.
- Consult the dealer or an experienced radio/TV technician for help.

Technical data

Information on technical data

General information about specifications

As long as nothing else is specified or listed, the technical data applies to the base model. Different values may result due to optional equipment, different model versions, special equipment, and country-specific equipment. The specifications in the legal vehicle documents always take precedence.

The drive and power of the vehicle are listed in the official vehicle registration.

Weight

The values for the curb weight in the following tables apply to a vehicle ready for operation with standard equipment, without driver, with fluids including 100% full fuel tank. Optional equipment and retrofitted equipment will increase the specified curb weight and reduce the possible load.

The load consists of the following weight:

- Passengers.
- All luggage inside and outside the vehicle.
- Attachments.
- Trailer tongue weight if in trailer mode.

The permitted total vehicle weight and the gross axle weight rating must never be exceeded. The permissible values are indicated on the safety compliance label or on the identification label on the B-pillar on the driver's side ⇒ [Safety certificate](#).

Performance

The performance was determined without equipment that limits performance, such as add-on parts.

Due to technical or legal reasons, the performance specifications and mileage may vary.

On some engines with heavy duty suspension, the speed maximum speed may be limited and lower.

Towing weight and trailer tongue weight ratings

The towing weight and trailer tongue weight ratings on the trailer hitch identification label are simply the test values for the trailer hitch. The vehicle-based specifications, which are often below these values, can be found in your vehicle documents. The information in the official vehicle registration or the safety compliance label ⇒ [Safety certificate](#) always takes priority.

Towing weight

The specified combination weights are only valid for heights of up to approximately 1000 m (approx. 3000 ft) above sea level. If this is exceeded, the maximum gross combination weight rating must be reduced by approximately 10%, and thereafter by an additional approx. 10% for each further approx. 1000 m (approx. 3000 ft) increment that is exceeded.

Incline angle

The incline angle is the specification up to which the vehicle is able to drive uphill on an angle with its own power. This can depend on the road conditions, the weather conditions, and the engine power, among other things. The values apply to a vehicle that is in motion and not to a vehicle that starts to drive from a stationary position.

A rising difference in altitude (incline) on a 100 m (approx. 300 ft) stretch is given in percentage or degrees (100% = 45 degrees).

Vehicle Identification Number (VIN)

Structure of the vehicle identification number (VIN)

The vehicle identification number (VIN, VIN) consists of 17 characters. These characters can be sorted into seven groups.

The structure is explained using the following examples of vehicle identification numbers.

Group	①			②			③		④	⑤	⑥	⑦					
Position	1	2	3	4	5	6	7	8	9	10	11	12	13	14	15	16	17
Example	W	V	W	Z	Z	Z	C	B	Z	R	E	4	0	0	9	5	3
	W	V	W	A	F	2	9	N	4	8	Y	0	0	0	0	0	1

① Vehicle manufacturer identification:

WVW Volkswagen Passenger Vehicles

WVG Volkswagen Passenger Vehicles

1VW Volkswagen Group of America Inc., Volkswagen de México, S.A. de C.V

3VW Volkswagen de México, S.A. de C.V

MFB Garuda Matraman Motor (Indonesia)

② Filler characters: The filler characters may vary depending on manufacturer, or contain information on the body shape and transmission type.

③ Vehicle class, depending on model:

14 ID.7

3H Arteon

5T Touran

6R Polo

AC T-Roc convertible

BV Golf

CB Passat

CA Atlas

RC Touareg

Depending on the manufacturer, digits 7 to 9 can also contain information on the fuel type (7) and vehicle class (8 and 9).

④ Filler characters or check digits: The filler characters or check digits may vary depending on the manufacturer.

⑤ VIN index, depending on model year:

R 2024

S 2025

T 2026

U 2027

⑥ Production location, plant where the vehicle was manufactured:

- C Volkswagen plant in Chattanooga
- D Volkswagen plant in Bratislava
- E Volkswagen plant in Emden
- K Volkswagen plant in Osnabrück
- M Volkswagen plant in Puebla
- P Volkswagen plant in Zwickau
- T Volkswagen plant in Pune
- U Volkswagen plant in Uitenhage
- V Volkswagen plant in Palmela
- W Volkswagen plant in Wolfsburg
- Y Volkswagen plant in Pamplona

The letter assignment for the production site may vary depending on the vehicle or be assigned twice.

⑦ Sequential production number for each model year.

Position of the vehicle identification number



Fig. 196 In the windshield: vehicle identification number (VIN)

The VIN can be read from the outside through the viewing window in the windshield. The viewing window is at the side of the

lower section of the windshield.

In some models, it may be possible to display the vehicle identification number in the Service menu or in the vehicle settings, depending on the Infotainment system. The vehicle identification number may also be located on the identification label.

The VIN may also be stamped in the following locations, depending on the model, country and engine:

- In the right water drain channel in the hood space.
- In the hood space near the hinge for the hood on the right-hand side of the vehicle.
- Under the carpet behind the right front seat

Safety certificate

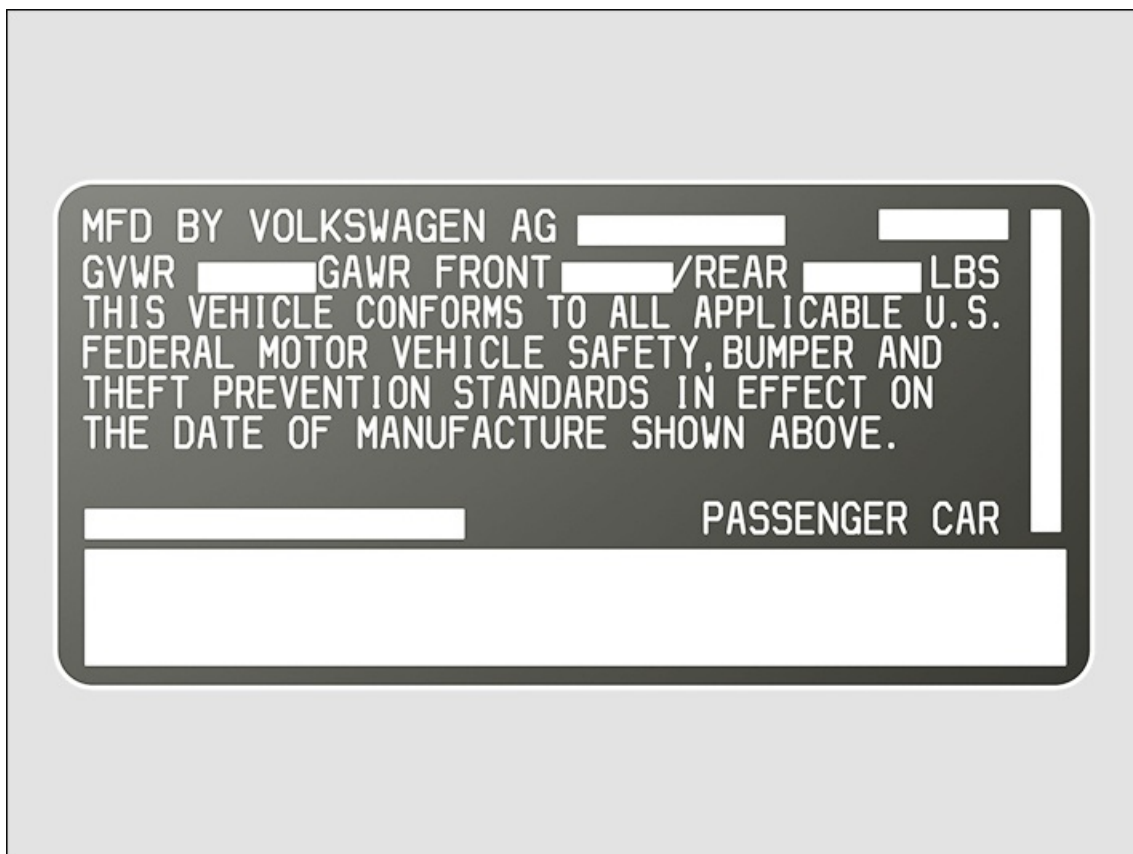

Fig. 197 Safety certificate (general example).

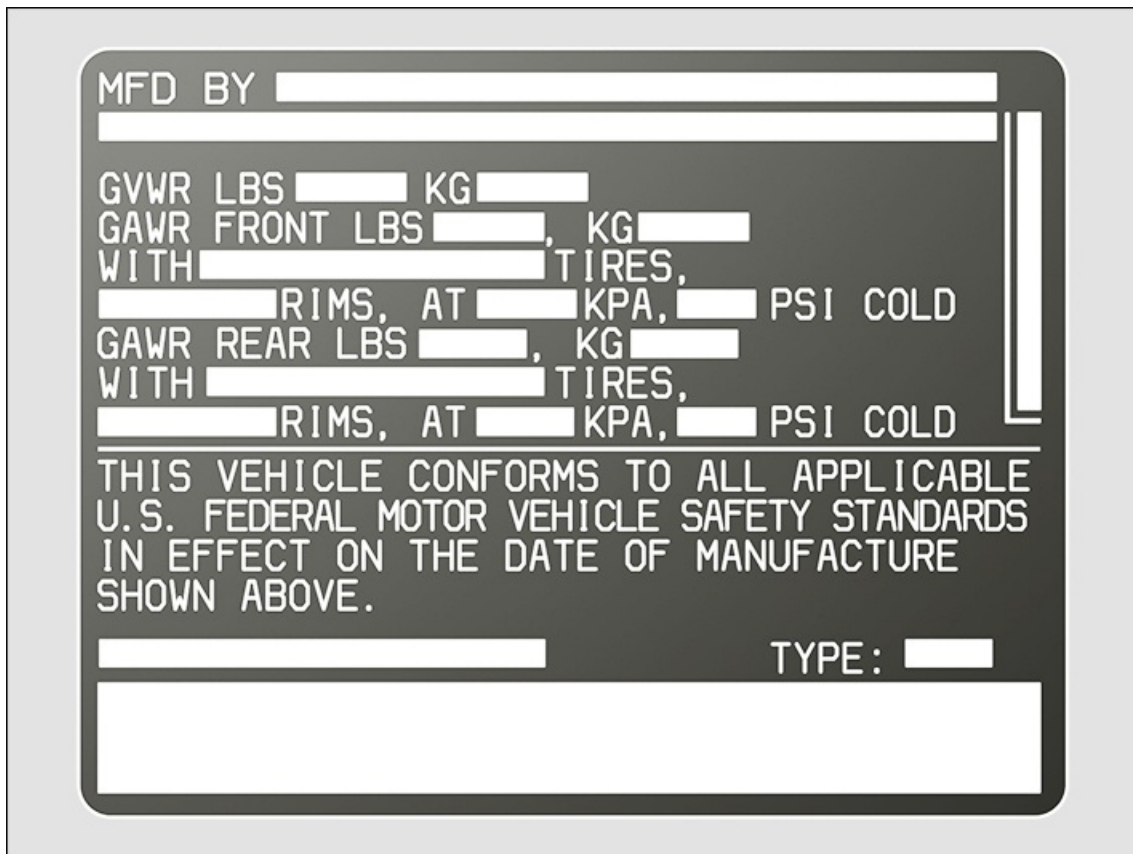

Fig. 198 Safety certificate (general example).

A safety certificate on the driver door pillar displays the following information:

- Manufacturer.
- Country of manufacture.
- Date of manufacture.
- Gross vehicle weight rating.
- Gross axle weight ratings.
- Tire size.
- Rim size
- Tire pressure.
- Vehicle Identification number.
- Type designation.

Dimensions

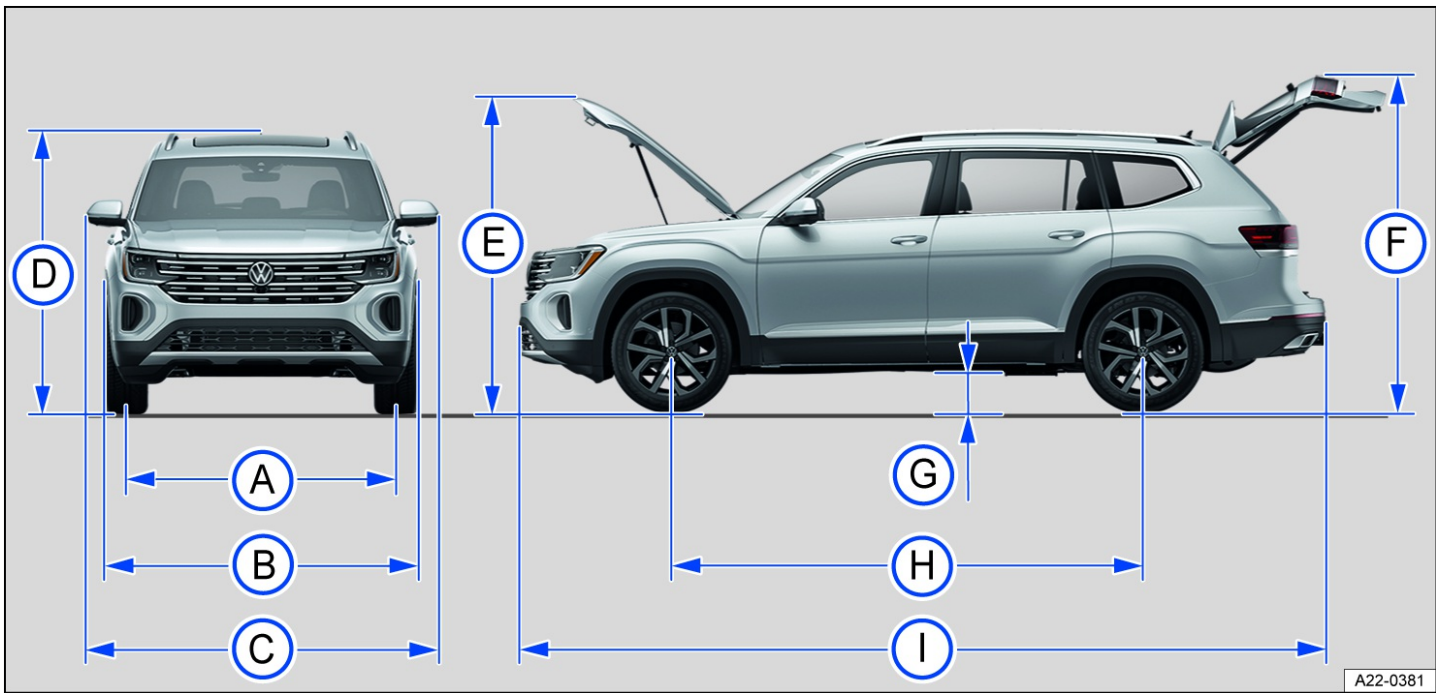

Fig. 199 Vehicle dimensions.

The information in the table applies for the standard model with standard equipment.

In the case of other rim and wheel sizes, additional equipment, different model versions and the retrofitting of accessories as well as in the case of special vehicles, these values may differ.

Information about how the weight specifications are compiled can be found in section [⇒ General information about specifications](#).

Where the vehicle dimensions are not given, the values were not available at the time of printing.

Key for <i>fig. 199</i> :			
A	Front track	mm (in)	1 7 0 2 (6 7 · 0)
	Rear track	mm (in)	1 7 1 8 (6 7 · 6)

Key for <i>fig. 199</i> :			
B	Width	mm (in)	1 9 9 0 (7 8 · 4)
C	Width from outside mirror to outside mirror	mm (in)	2 2 4 9 (8 8 · 5)
	Width from outside mirror to outside mirror (outside mirrors folded in)	mm (in)	2 0 8 5 (8 2 · 1)
D	Height at curb weight	mm (in)	1 7 8 9 (7 0 · 4)

Key for <i>fig. 199</i> :			
E	Height with open hood and curb weight	mm (in)	1 9 1 6 (7 5 · 4)
F	Height with open trunk lid and curb weight	mm (in)	2 1 2 8 (8 3 · 8)
G	Ground clearance at curb weight between the axles	mm (in)	1 6 0 (6 · 3)
H	Wheelbase with curb weight	mm (in)	2 9 8 0 (1 1 7 · 3)

Key for <i>fig. 199</i> :			
	Minimum turning circle diameter	m (ft)	1 2 · 3 5 (4 0 · 5)
①	Length from bumper to bumper	mm (in)	5 0 9 7 (2 0 0 · 7)

①	Length with factory-installed trailer hitch	mm (in)	– (–)
---	---	------------	----------

Fuel tank volume

The fuel tank has the following volume:

- approx. 70 l (approx. 18.6 gal)

 The capacity of the fuel tank includes an indeterminate reserve quantity that remains in the fuel tank when the fuel gage shows that the fuel tank is empty. The reserve quantity is variable and cannot reliably serve to increase the remaining range.

Gasoline engines

2.0 l, 4 cylinder, FSI®, 201 kW (270 hp), gasoline engine

Engine overview

Output	kW	201 at 5250 – 6000 rpm
	hp	270 at 5250 – 6000 rpm
Engine code (EC)		DRKB
Maximum torque	Nm	370 at 1550 – 4900 rpm
	ft-lb	273 at 1550 – 4900 rpm

Transmission		AG8	AG8 4 Motion
Maximum speed	km/h	–	
	mph	–	–

Weight specifications and axle loads

		AG8	AG8 4 Motion		SE L, SE L P re m iu m
		FWD	SE, SE w/Tech	Peak Edition	
Curb weight	kg	1958	2037	2087	2 1 0 6
	lbs	4317	4491	4601	4 6 4 3
Gross Vehicle Weight Rating	kg	2590	2680	2670	2 6 9 0
	lbs	5710	5908	5886	5 9 3 0

Front Gross Axle Weight Rating	kg	1280	1310	1310	1320
	lbs	2822	2888	2888	2910
Rear Gross Axle Weight Rating	kg	1360	1420	1410	1420
	lbs	2998	3131	3109	3131

Towing weight with trailer hitch installed at the factory

		AG8	AG8 4 Motion		
Transmission		FWD	SE, SE w/Tech	Peak Edition	SE, SEL, SE L P re m iu m
Braked towing weight	kg	2268	2268	2268	2268
	lbs	5000	5000	5000	5000
Unbraked towing weight	kg	748	748	748	748

	lbs	1650	1650	1650	1650
Maximum gross combination weight rating	kg	4486	4586	4559	4586
	lbs	9890	10110	10050	10110
Maximum permissible trailer tongue weight rating	kg	227	227	227	227
	lbs	500	500	500	500

Towing weight without trailer hitch installed at the factory

		AG8	AG8 4 Motion		
Transmission		FWD	SE, SE w/Tech	Peak Edition	SELT Premium
Braked towing weight	kg	907	907	907	907
	lbs	2000	2000	2000	2000
Unbraked towing weight	kg	748	748	748	748

	lbs	1650	1650	1650	1650
Maximum gross combination weight rating	kg	3493	3583	3574	3597
	lbs	7700	7900	7880	7930
Maximum permissible trailer tongue weight rating	kg	227	227	227	227
	lbs	500	500	500	500

³⁾ This data was not available at the time of printing.

⁴⁾ You can find the exact curb weight on the vehicle's identification label or safety compliance label.

⁵⁾ This data was not available at the time of printing.

⁶⁾ If the vehicle is approved for trailer mode, note applicable local rules and regulations for driving with a trailer and the use of trailer hitch.

⁷⁾ This data was not available at the time of printing.

⁸⁾ If the vehicle is approved for trailer mode, note applicable local rules and regulations for driving with a trailer and the use of trailer hitch.

⁹⁾ This data was not available at the time of printing.

Abbreviations used

Abbreviation Meaning